



US007232105B2

(12) **United States Patent**
Want et al.

(10) **Patent No.:** **US 7,232,105 B2**
(45) **Date of Patent:** **Jun. 19, 2007**

(54) **METHOD AND APPARATUS FOR HANGING A MEDICAL DEVICE**

(75) Inventors: **Nicholas Want**, Manchester, NH (US);
Scott Edward Corbeil, Litchfield, NH (US);
Marc A. Laroche, Manchester, NH (US)

(73) Assignee: **Atrium Medical Corporation**, Hudson, NH (US)

(*) Notice: Subject to any disclaimer, the term of this patent is extended or adjusted under 35 U.S.C. 154(b) by 150 days.

(21) Appl. No.: **10/694,147**

(22) Filed: **Oct. 27, 2003**

(65) **Prior Publication Data**

US 2005/0087660 A1 Apr. 28, 2005

(51) **Int. Cl.**
F16M 11/00 (2006.01)

(52) **U.S. Cl.** **248/691**; 248/215; 248/304;
248/308; 248/340; 248/341; 248/692; 128/DIG. 24;
604/322

(58) **Field of Classification Search** 248/95,
248/215, 690-692, 339-341, 517, 304, 308;
215/399; 206/806; 220/751, 756, 759, 770;
128/DIG. 24; 604/322; 294/142, 143
See application file for complete search history.

(56) **References Cited**

U.S. PATENT DOCUMENTS

617,284	A *	1/1899	Darnes	221/283
3,163,338	A *	12/1964	Gottsegen	224/484
3,424,422	A *	1/1969	Klangos	248/561
3,630,251	A *	12/1971	Ross	220/751
3,690,315	A *	9/1972	Chittenden et al.	604/324
3,804,310	A *	4/1974	Wheeler	294/142

3,995,803	A *	12/1976	Uitz	224/432
4,189,789	A *	2/1980	Hofstetter	4/144.1
4,219,177	A *	8/1980	O'Day	248/215
4,258,893	A *	3/1981	Tolley	248/447.1
4,440,371	A *	4/1984	Wijsman	248/318
4,658,834	A *	4/1987	Blankenship et al.	600/584
4,747,843	A *	5/1988	Felix et al.	604/318
4,750,697	A *	6/1988	Tontarelli	248/215
4,756,501	A *	7/1988	Quercia et al.	248/340
4,951,484	A *	8/1990	Rohald et al.	70/59
5,224,607	A *	7/1993	Koresko	211/34
5,352,006	A *	10/1994	Ocuin	294/142
5,393,113	A *	2/1995	Walsh	294/170
5,527,007	A *	6/1996	Weilbacher	248/304
5,575,446	A *	11/1996	Swenson et al.	248/304
D393,587	S	4/1998	Valerio et al.		
5,749,497	A *	5/1998	Davis	222/181.2
5,865,408	A *	2/1999	Swisher et al.	248/188.1
D436,838	S *	1/2001	Kirk	D8/370
6,368,311	B1	4/2002	Valerio et al.		
6,651,941	B1 *	11/2003	Kinsel	248/100

FOREIGN PATENT DOCUMENTS

JP 2000262590 A * 9/2000

* cited by examiner

Primary Examiner—Korie Chan

(74) *Attorney, Agent, or Firm*—RatnerPrestia

(57) **ABSTRACT**

An apparatus for hanging a medical device is provided. The apparatus includes a shaft, a mounting portion coupled to an end portion of the shaft and configured for mounting the apparatus for movement with respect to the medical device, and a hook portion positioned at an opposite end portion of the shaft and configured for hanging the apparatus from a support. The shaft is configured to permit rotation of the hook portion with respect to the mounting portion, thereby facilitating orientation of the hook portion with respect to the support.

19 Claims, 4 Drawing Sheets

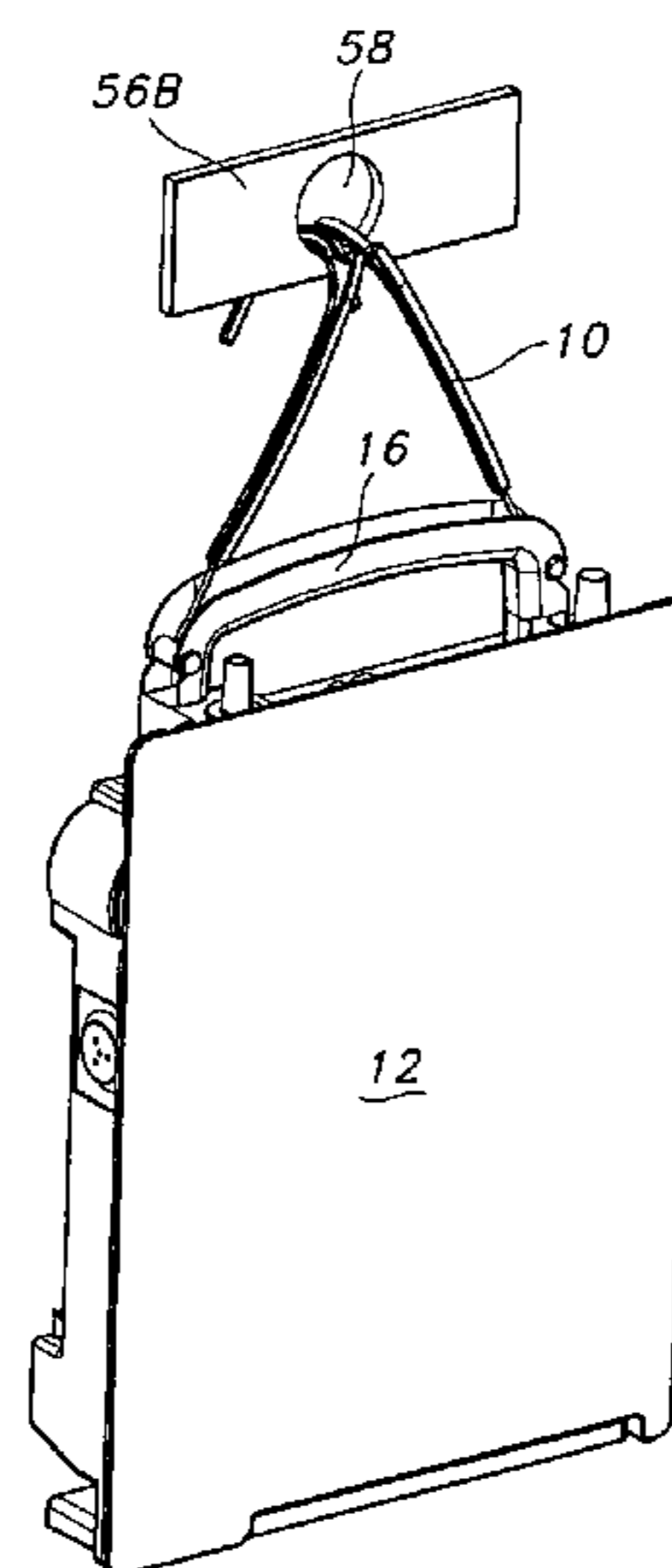
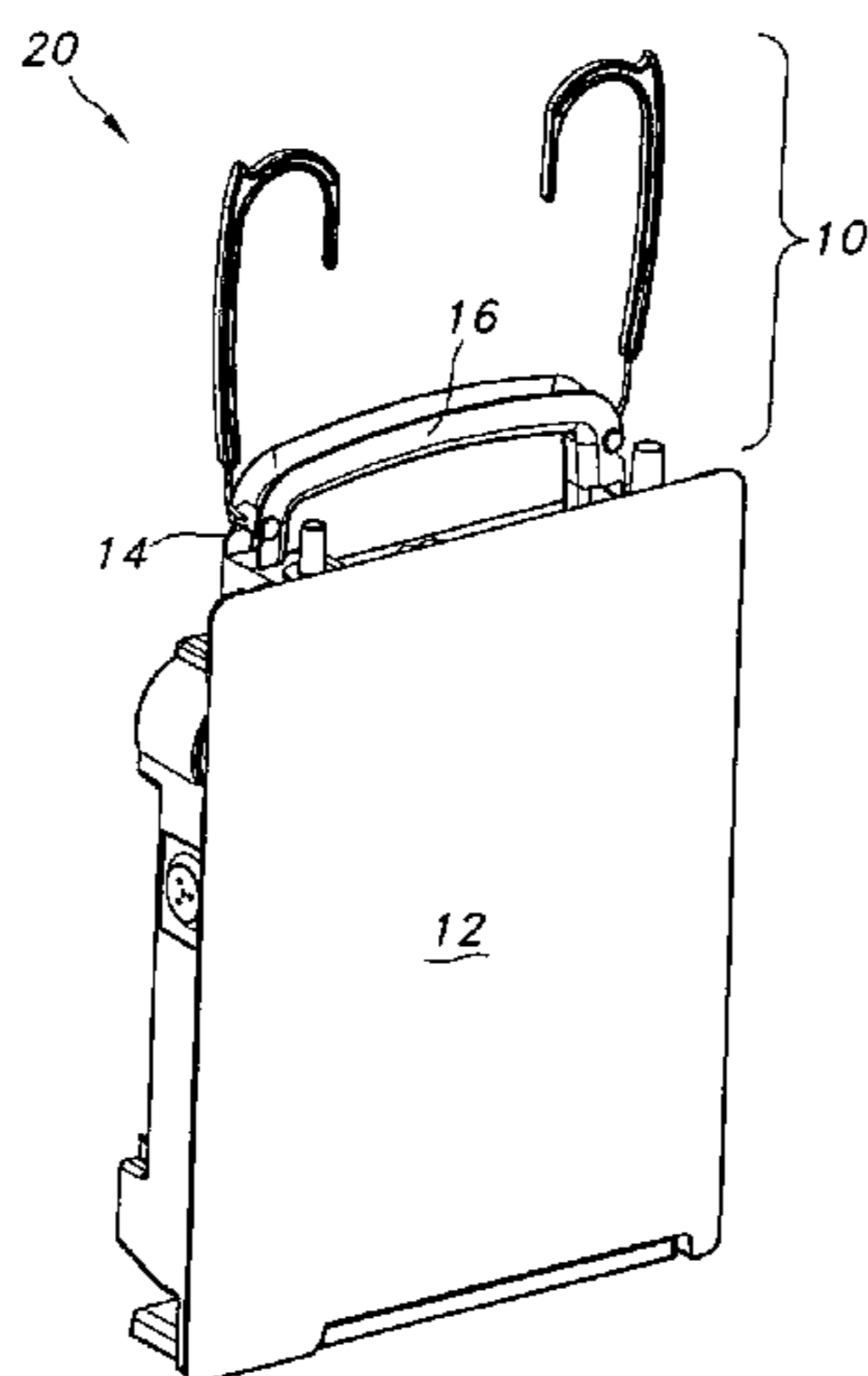

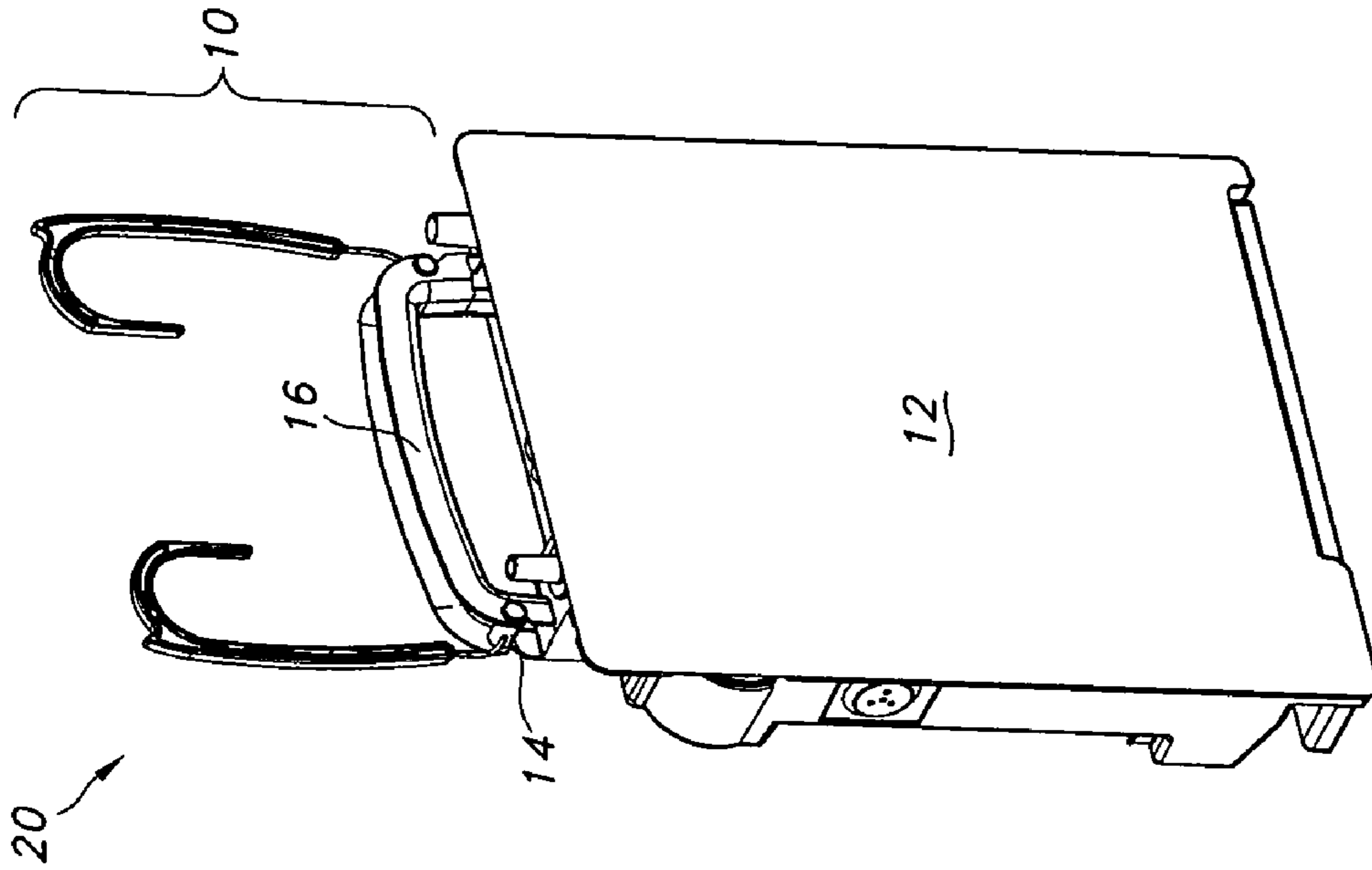

FIG. 2

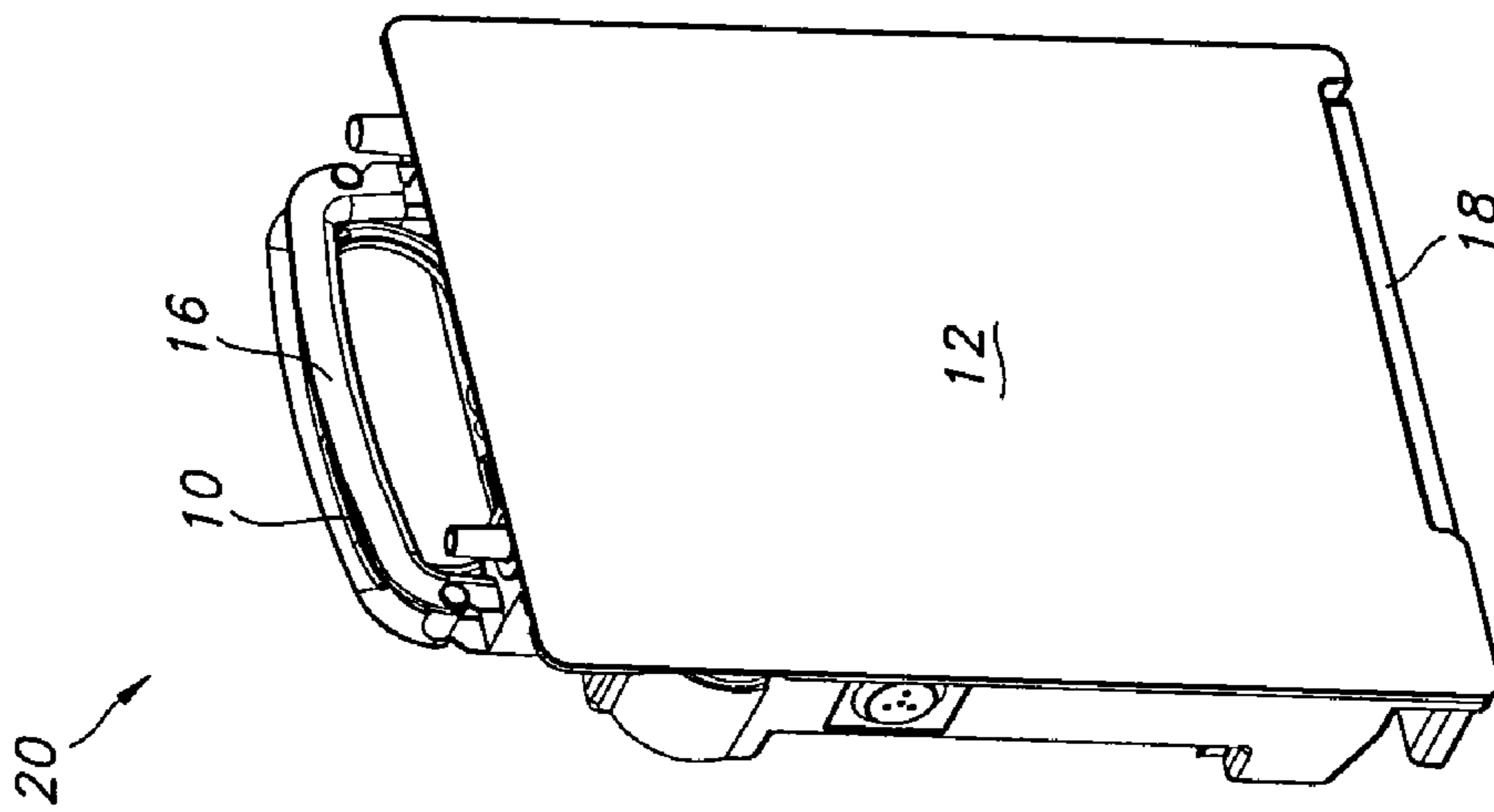

FIG. 1

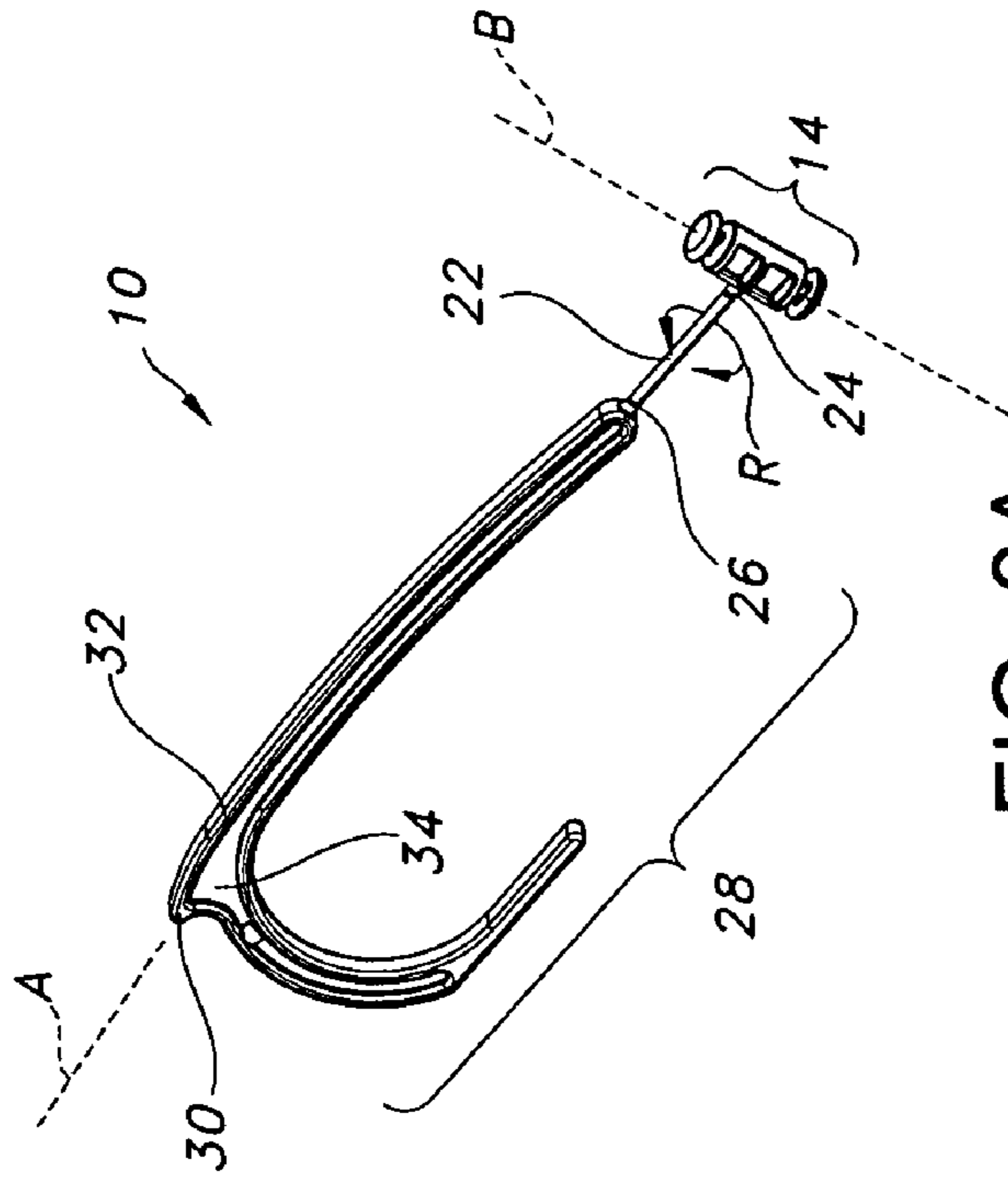

FIG. 3A

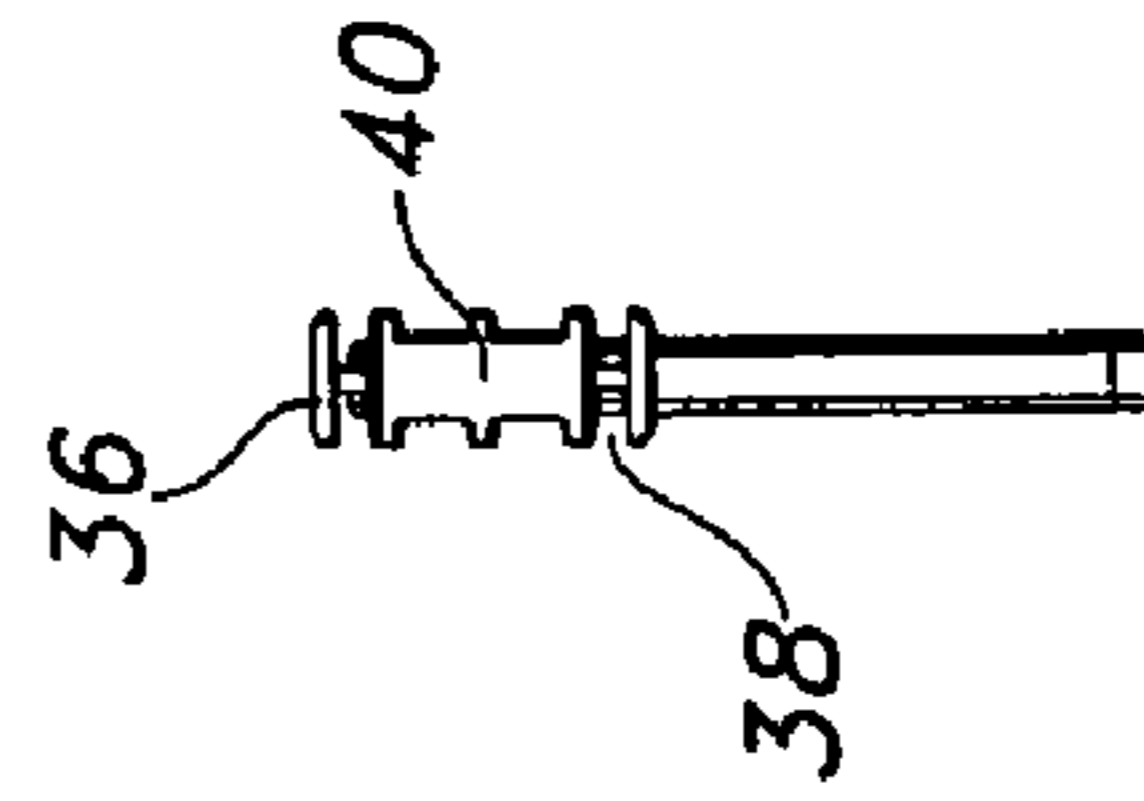

FIG. 3D

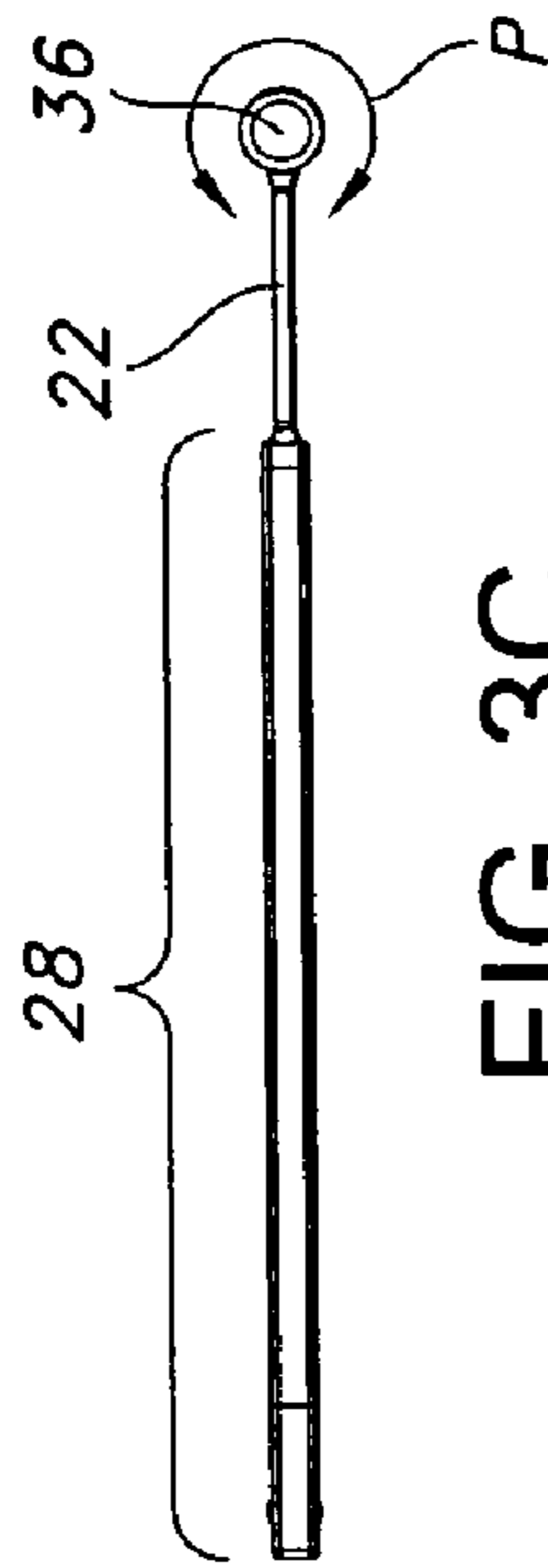

FIG. 3C

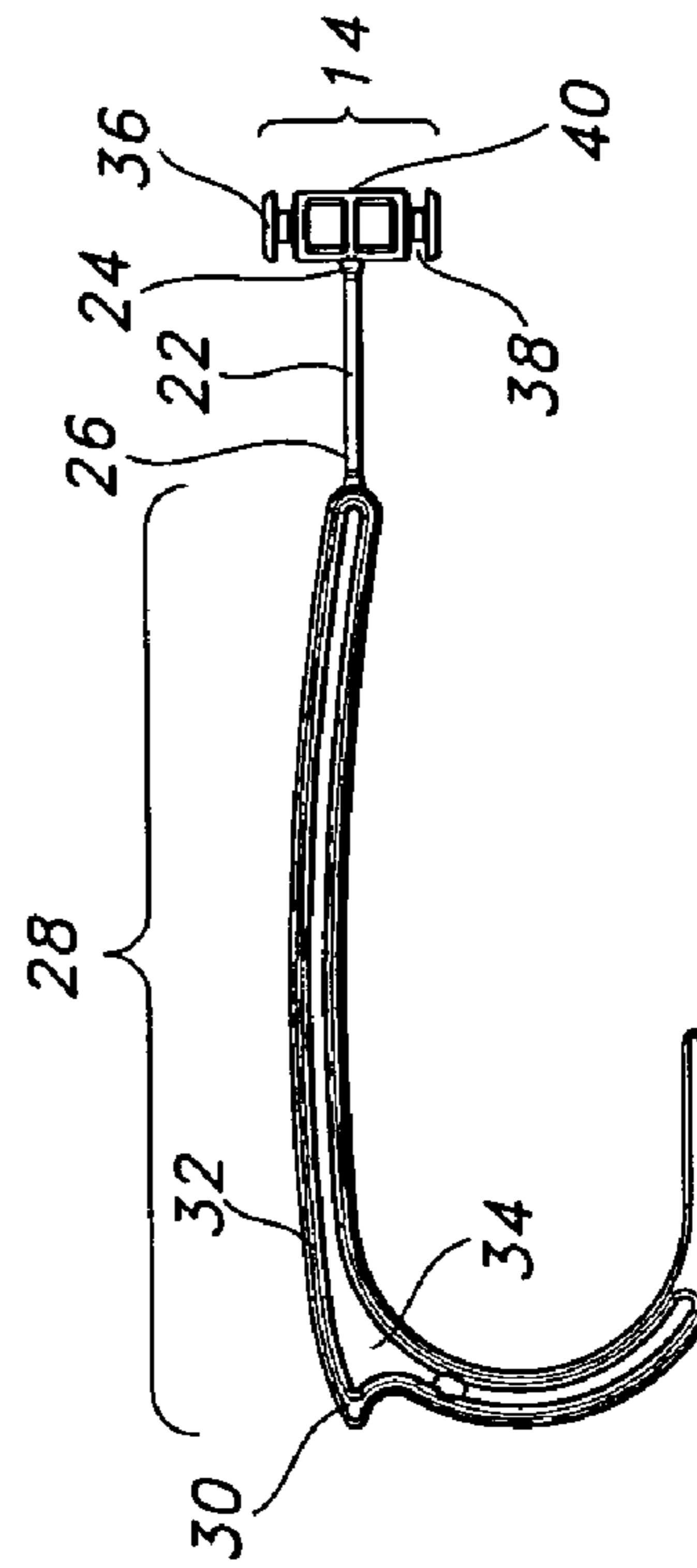

FIG. 3B

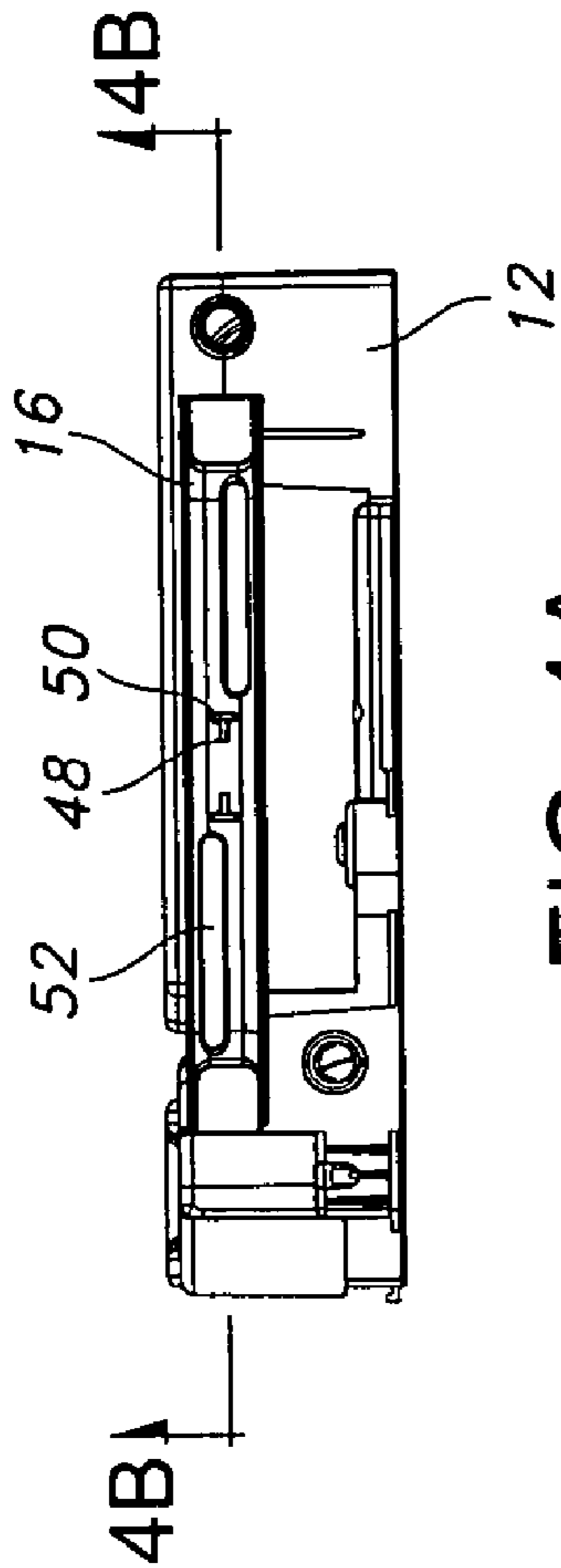
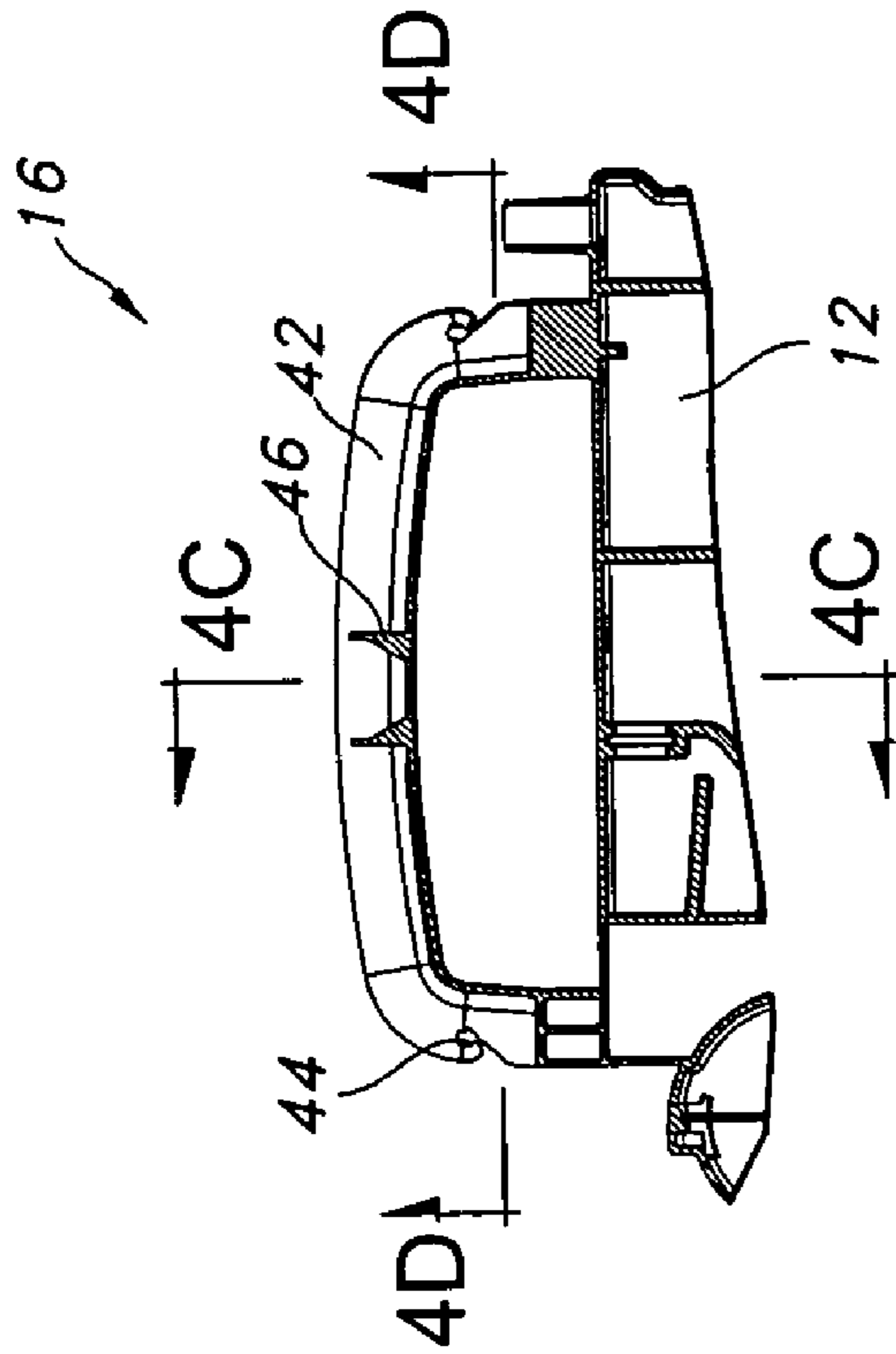

FIG. 4A

FIG. 4B

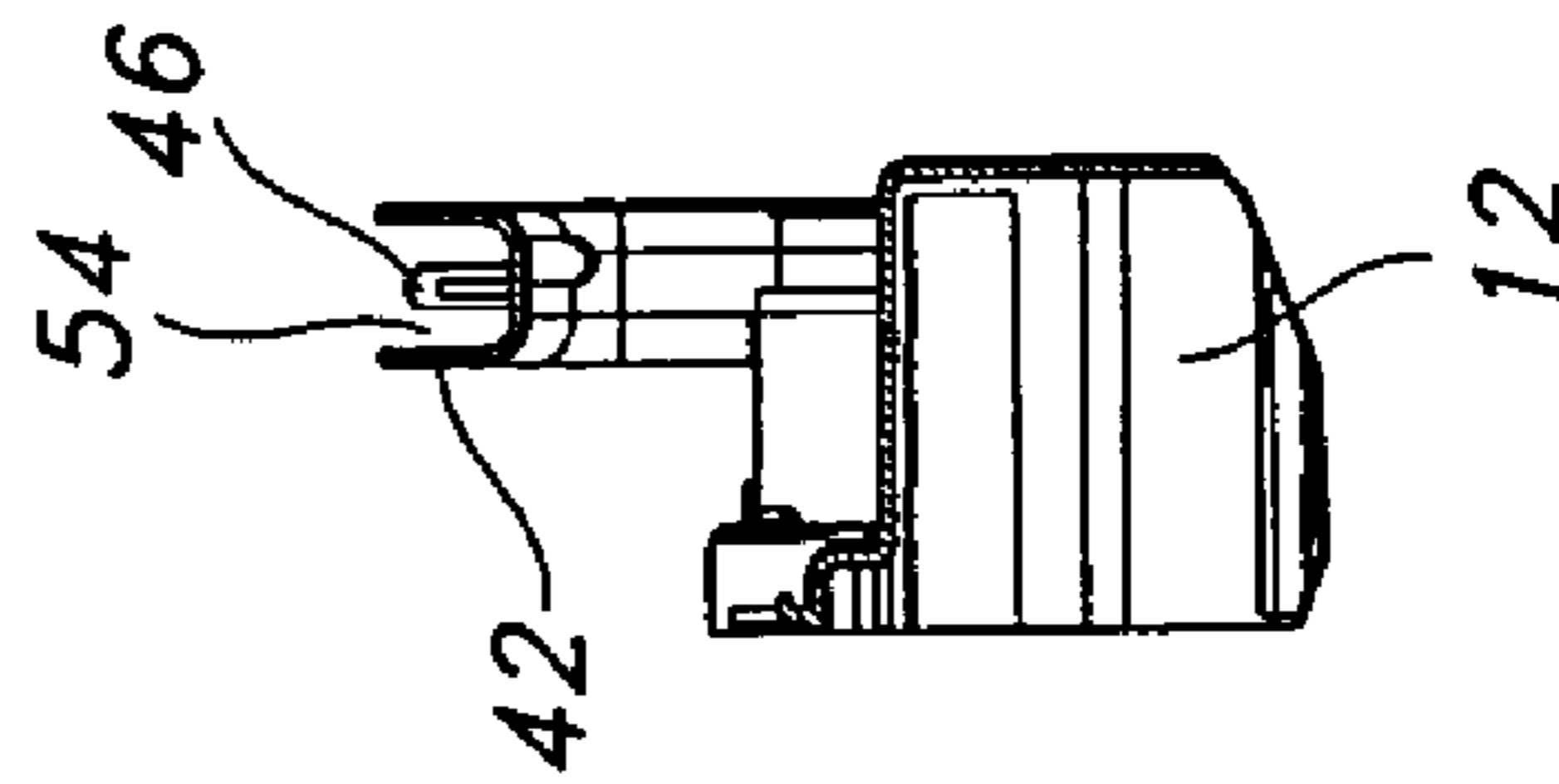

FIG. 4C

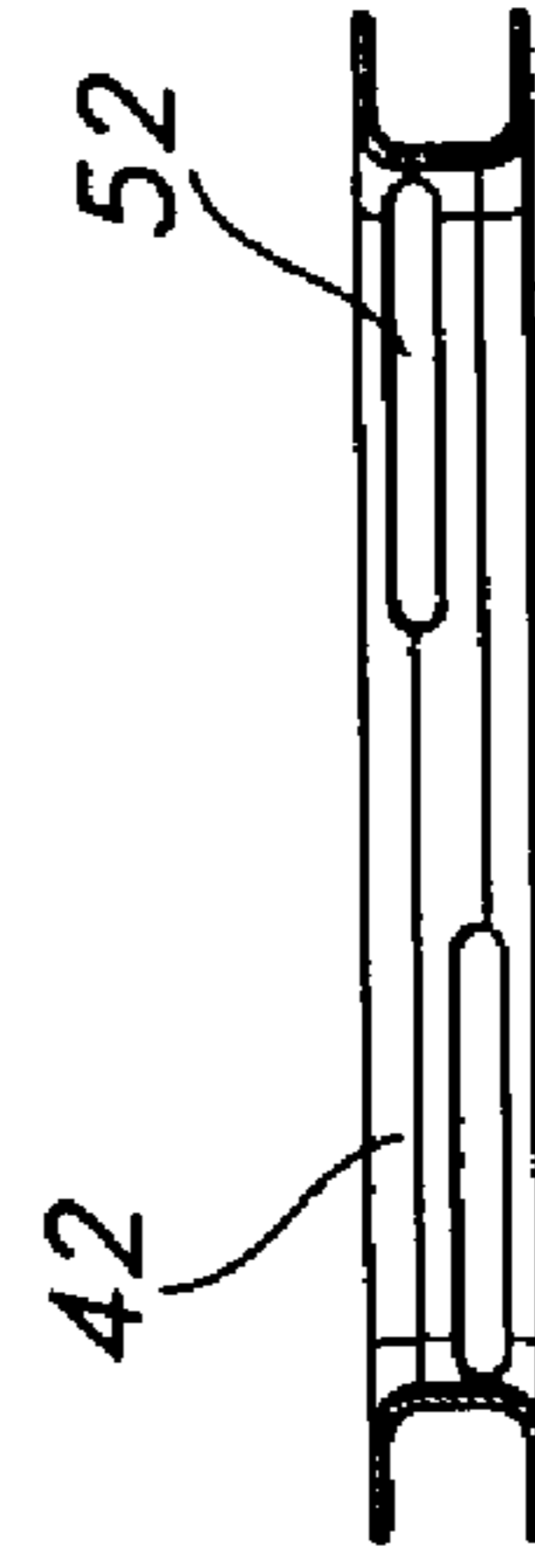

FIG. 4D

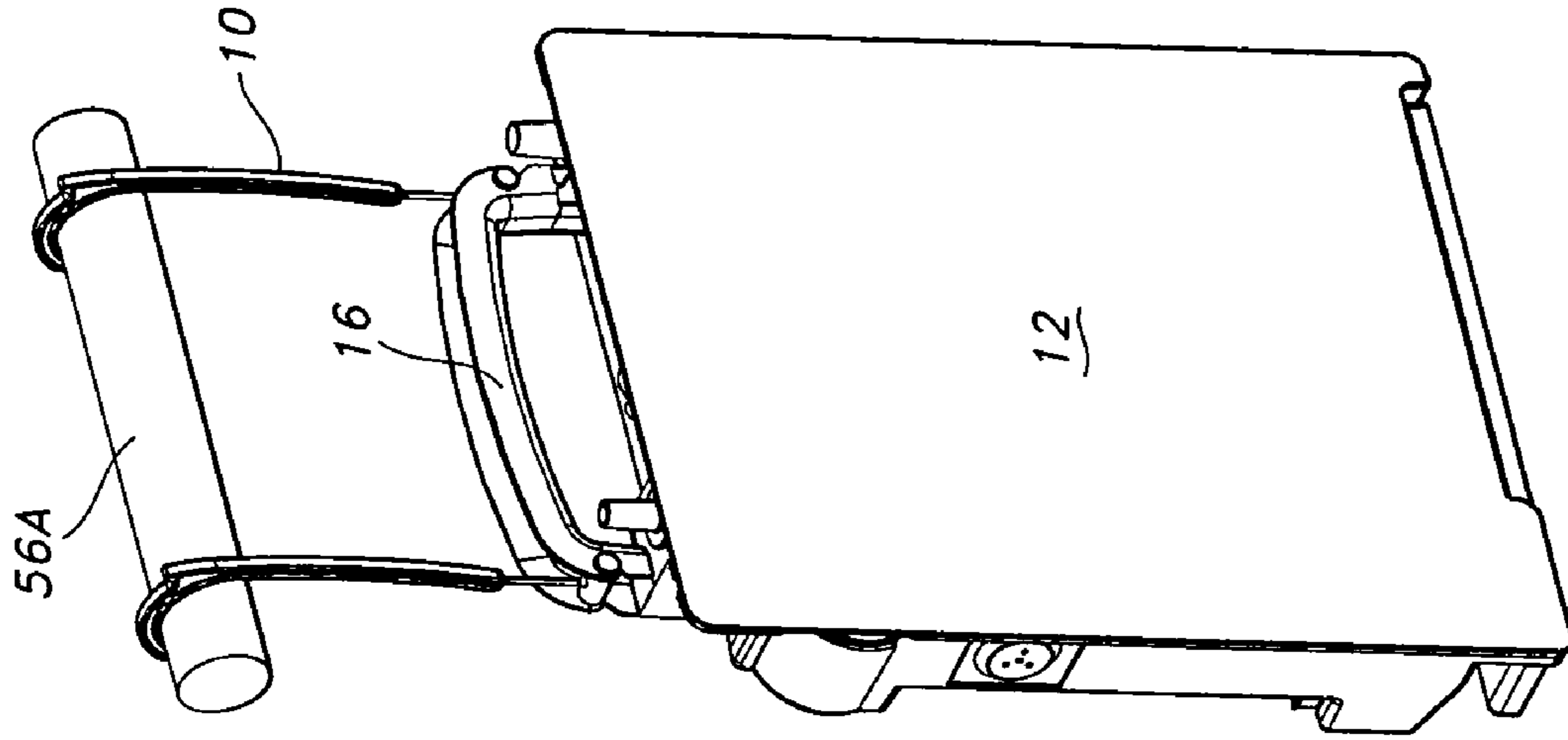

FIG. 5

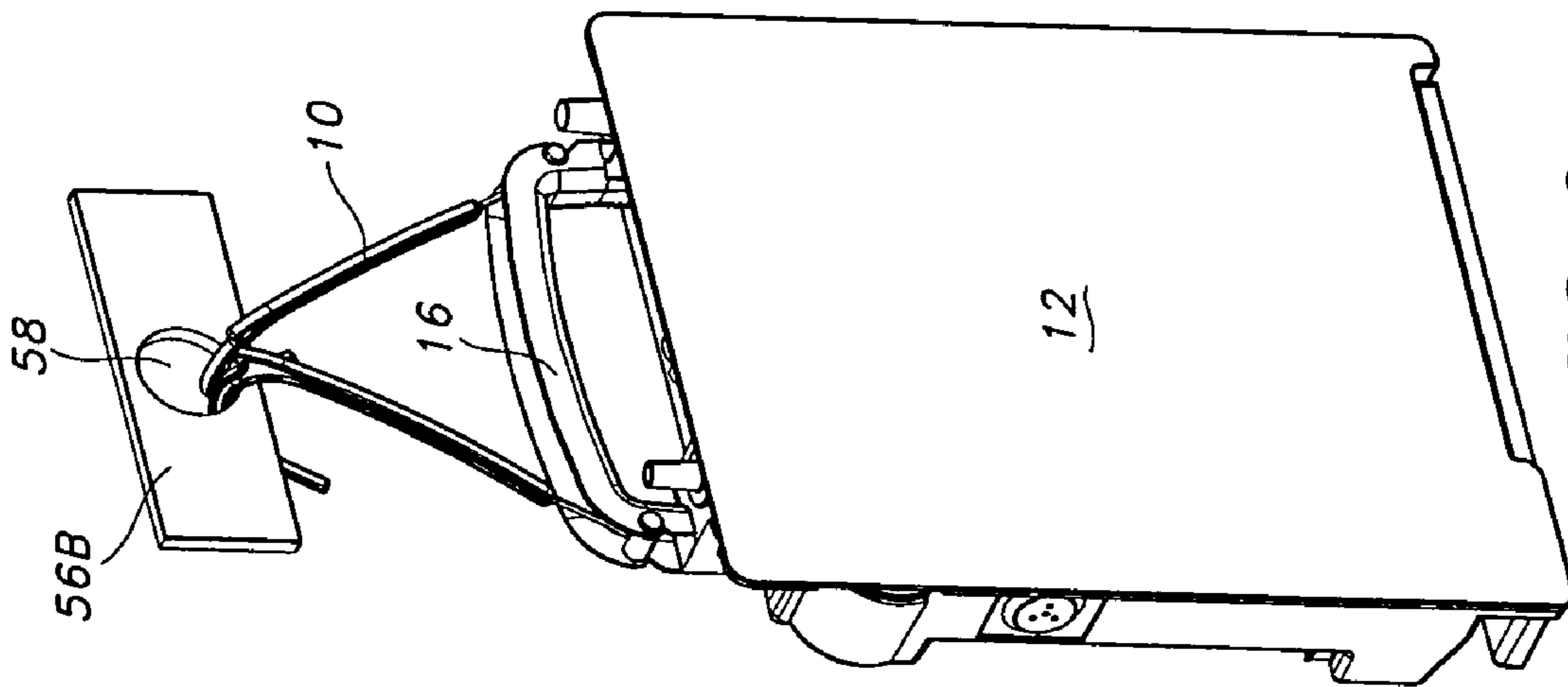

FIG. 6

1**METHOD AND APPARATUS FOR HANGING
A MEDICAL DEVICE**

FIELD OF THE INVENTION

The present invention relates to an apparatus for hanging a medical device. More specifically, the present invention relates to an apparatus configured for hanging a medical device such as a chest drain to a support during use.

BACKGROUND OF THE INVENTION

A wide variety of medical devices are utilized in health care and hospital settings. One example of a medical device is a fluid recovery system such as a chest drain, also known as a thoracic cavity drain. Generally, a chest drain is a relatively compact bedside vessel employed to collect fluids postoperatively from a closed surgical site, for example, through a catheter implanted in the patient's chest.

A chest drain is sometimes positioned on a hospital room floor when it is difficult to find an appropriate support to which the chest drain can be mounted, which increases the difficulty of monitoring the volume of fluid collected within the collection chamber of the chest drain system or otherwise manipulating the chest drain.

Accordingly, there is a need for an apparatus that quickly and easily secures a medical device such as a fluid recovery system to a support, such as a hospital bed side-rail or other support.

SUMMARY OF THE INVENTION

In one exemplary embodiment, this invention provides an apparatus for hanging a medical device. The apparatus includes a shaft, a mounting portion coupled to an end portion of the shaft and configured for mounting the apparatus for movement with respect to the medical device, and a hook portion positioned at an opposite end portion of the shaft and configured for hanging the apparatus from a support. The shaft is configured to permit rotation of the hook portion with respect to the mounting portion, thereby facilitating orientation of the hook portion with respect to the support.

In another exemplary embodiment, an assembly configured to be hung from a support is provided. The assembly includes a medical device and at least one hanger. Each hanger includes a shaft, a mounting portion coupled to an end portion of the shaft and coupled for movement with respect to the medical device, and a hook portion positioned at an opposite end portion of the shaft and configured for hanging from the support. The shaft of the hanger is configured to permit rotation of the hook portion with respect to the mounting portion of the hanger, thereby facilitating orientation of the hook portion with respect to the support.

In yet another exemplary embodiment, an assembly configured to be hung from a support is provided. The assembly includes a medical device and a plurality of hangers. Each hanger includes a shaft, a mounting portion coupled to an end portion of the shaft and coupled for pivotal movement with respect to the medical device, and a hook portion positioned at an opposite end portion of the shaft and configured for hanging from the support. The hangers are pivotable with respect to the medical device, thereby facilitating deployment of the hangers with respect to the medical device to an extended position. Furthermore, the hangers are positioned adjacent one another in the extended position for hanging from a substantially common point on the support.

2

In another exemplary embodiment, an assembly configured to be hung from a support is provided. The assembly includes a medical device, a handle coupled to the medical device and configured for grasping the medical device, and at least one hanger. The hanger includes a shaft, a mounting portion coupled to an end portion of the shaft and coupled to the handle, and a hook portion positioned at an opposite end portion of the shaft and configured for hanging from the support. The hanger is pivotable with respect to the handle, thereby facilitating deployment and retraction of the hanger with respect to the handle.

In yet another exemplary embodiment, in an assembly of a medical device and a plurality of hangers, a method of hanging the medical device to a support is provided. At least a portion of a shaft of each hanger is rotated with respect to a mounting portion of each hanger, thereby orienting a hook portion of each hanger with respect to the support. The hook portions of the hangers are positioned adjacent one another. The hook portion of each hanger is engaged to a substantially common point on the support, thereby hanging the medical device.

In another exemplary embodiment, in an assembly of a medical device and a plurality of hangers, a method of hanging the medical device to a support is provided. A mounting portion of each hanger is pivoted with respect to the medical device, thereby deploying a hook portion of each hanger with respect to the medical device. The hook portions of the hangers are positioned adjacent one another. The hook portion of each hanger is engaged to a substantially common point on the support, thereby hanging the medical device.

In still another embodiment, the assembly includes a medical device and a handle configured for grasping the medical device, the handle defining at least one aperture. At least a portion of the hanger extends into the aperture in the handle.

BRIEF DESCRIPTION OF THE DRAWINGS

FIG. 1 is a perspective view of an exemplary embodiment of an assembly illustrating a medical device and a handle, shown with hanger components in a retracted position according to aspects of this invention;

FIG. 2 is a perspective view of the assembly of FIG. 1, showing the hangers in a deployed position;

FIG. 3A is a detailed perspective view of a hanger of FIG. 1 according to aspects of this invention;

FIG. 3B is a front view of the hanger of FIG. 3A;

FIG. 3C is a top view of the hanger of FIG. 3A;

FIG. 3D is a right side view of the hanger of FIG. 3A;

FIG. 4A is a plan view of the assembly of FIG. 1 shown without the hangers according to aspects of this invention;

FIG. 4B is a front cross-sectional view of the handle of the assembly of FIG. 4A;

FIG. 4C is a right side cross-sectional view of the assembly of FIG. 4B;

FIG. 4D is a bottom cross-sectional view of the handle of the assembly of FIG. 4B;

FIG. 5 is a perspective view the assembly of FIG. 2 shown with the hangers deployed and hanging from a cylindrical support according to aspects of this invention; and

FIG. 6 is a perspective view the assembly of FIG. 2 shown with the hangers deployed and hanging from an aperture within a support according to aspects of this invention.

DETAILED DESCRIPTION OF THE
INVENTION

Although the invention is illustrated and described herein with reference to specific embodiments, the invention is not intended to be limited to the details shown. Rather, various modifications may be made in the details within the scope and range of equivalents of the claims and without departing from the invention.

Referring to the figures generally, in an exemplary embodiment an apparatus 10 for hanging a medical device 12 includes a shaft 22, a mounting portion 14 coupled to an end portion 24 of the shaft 22 and configured for mounting the apparatus 10 for movement with respect to the medical device 12, and a hook portion 28 positioned at an opposite end portion 26 of the shaft 22 and configured for hanging the apparatus 10 from a support 56A, 56B. The shaft 22 is configured to permit rotation of the hook portion 28 with respect to the mounting portion 14, thereby facilitating orientation of the hook portion 28 with respect to the support 56A, 56B.

In another exemplary embodiment, an assembly 20 configured to be hung from a support 56A, 56B is provided. The assembly 20 includes a medical device 12 and at least one hanger 10. Each hanger 10 includes a shaft 22, a mounting portion 14 coupled to an end portion 24 of the shaft 22 and coupled for movement with respect to the medical device 12, and a hook portion 28 positioned at an opposite end portion 26 of the shaft 22 and configured for hanging from the support 56A, 56B. The shaft 22 of the hanger 10 is configured to permit rotation of the hook portion 28 with respect to the mounting portion 14 of the hanger 10, thereby facilitating orientation of the hook portion 28 with respect to the support 56A, 56B.

In yet another exemplary embodiment, an assembly 20 configured to be hung from a support 56A, 56B is provided. The assembly 20 includes a medical device 12 and a plurality of hangers 10. Each hanger 10 includes a shaft 22, a mounting portion 14 coupled to an end portion 24 of the shaft 22 and coupled for pivotal movement with respect to the medical device 12, and a hook portion 28 positioned at an opposite end portion 26 of the shaft 22 and configured for hanging from the support 56A, 56B. The hangers 10 are pivotable with respect to the medical device 12, thereby facilitating deployment of the hangers 10 with respect to the medical device 12 to an extended position. Furthermore, the hangers 10 are positioned adjacent one another in the extended position for hanging from a substantially common point on the support 56B.

In another exemplary embodiment, an assembly 20 configured to be hung from a support 56A, 56B is provided. The assembly 20 includes a medical device 12, a handle 16 coupled to the medical device 12 and configured for grasping the medical device 12, and at least one hanger 10. The hanger 10 includes a shaft 22, a mounting portion 14 coupled to an end portion 24 of the shaft 22 and coupled to the handle 16, and a hook portion 28 positioned at an opposite end portion 26 of the shaft 22 and configured for hanging from the support 56A, 56B. The hanger 10 is pivotable with respect to the handle 16, thereby facilitating deployment and retraction of the hanger with respect to the handle 16.

In yet another exemplary embodiment, in an assembly of a medical device 12 and a plurality of hangers 10, a method of hanging the medical device 12 to a support 56A, 56B is provided. At least a portion of a shaft 22 of each hanger 10 is rotated with respect to a mounting portion 14 of each

hanger 10, thereby orienting a hook portion 28 of each hanger 10 with respect to the support 56A, 56B. The hook portions 28 of the hangers 10 are positioned adjacent one another. The hook portion 28 of each hanger 10 is engaged to a substantially common point on the support 56B, thereby hanging the medical device 12.

In another exemplary embodiment, in an assembly of a medical device 12 and a plurality of hangers 10, a method of hanging the medical device 12 to a support 56A, 56B is provided. A mounting portion 14 of each hanger 10 is pivoted with respect to the medical device 12, thereby deploying a hook portion 28 of each hanger 10 with respect to the medical device 12. The hook portions 28 of the hangers 10 are positioned adjacent one another. The hook portion 28 of each hanger 10 is engaged to a substantially common point on the support 56B, thereby hanging the medical device.

In still another embodiment, the assembly includes a medical device 12 having a handle 16 configured for grasping the medical device 12, the handle 16 defining at least one aperture such as slot 52. At least a portion of the hanger 10 extends into the aperture 52 in the handle 16.

Referring now to FIGS. 1 and 2, an assembly embodying exemplary aspects of this invention is generally designated by the numeral "20." The assembly 20 is configured to be hung from a support 56A, 56B (as illustrated in FIGS. 5 and 6). The assembly 20 includes a medical device 12, a handle 16 attached to the medical device 12, hangers 10, and a swiveling base 18. The medical device 12 can be any medical device. For example, the medical device 12 can be a fluid recovery system such as a thoracic chest drainage system. The swiveling base 18 (shown in a retracted position) can be rotated to an extended position to provide a pedestal for the assembly 20. Though not shown, the assembly 20 also includes hoses for the introduction of matter from the pleural cavity of a patient and for the drawing of a vacuum.

Each hanger includes a mounting portion 14 for attachment to the handle 16. FIG. 1 shows the hangers 10 in a retracted or stowed position, while FIG. 2 shows the hangers 10 in a deployed or extended position. Ornamental features of the handle 16 are illustrated in co-pending Design Patent Application No. 29/192,612, now U.S. Pat. No. D517,897, which is incorporated herein by reference. The handle 16 can have a wide variety of ornamental shapes and configurations, including a variety of proportions, thicknesses, cross-sections, and curvatures. For example, ornamentation is provided by the arc-shaped profile of the handle 16, the "U" shaped cross-section of the handle 16, and the proportional size of the handle 16 with respect to the width and height of the medical device 12, among others.

FIGS. 3A-3D illustrate the hanger 10 in greater detail. Each hanger 10 includes a shaft 22, a mounting portion 14 coupled to an end portion 24 of the shaft 22, and a hook portion 28 positioned at an opposite end portion 26 of the shaft 22. A finger tab 30 is positioned to facilitate manipulation of the hook portion 28 with respect to the medical device 12. The finger tab 30 provides a surface by which a user of the medical device 12 can engage the hanger 10 to move the hanger 10 from its retracted position (FIG. 1) to its extended position (FIG. 2).

The hanger 10 is optionally molded such that the shaft 22, the mounting portion 14, and the hook portion 28 are integrally formed with respect to one another. Alternatively, the hanger 10 can be formed from an assembly of two or more components of the same or different materials. If molded, hanger 10 is optionally formed from plastic. Alter-

natively, hanger **10** can be formed from metallic or other materials using any known manufacturing technology.

The hanger **10** is in its relaxed position when the hook portion **28** resides in a plane of axis “B” of the mounting portion **14**, as illustrated in FIGS. 3A-3D. The cross-sectional shape of the hook portion **28** includes a flanged perimeter **32** and a thinner central region **34**. The flanged perimeter **32** adds structural strength to the hook portion **28** to help ensure that the hook portion **28** will retain its shape when hung from a support. The cross-sectional shape of the hook portion **28** is not limited to such a configuration, however. For example, the perimeter **32** may be thinner than the central region **34**. Alternatively, the thickness of the hook portion **28** may be constant.

The mounting portion **14** is generally cylindrical in shape, oriented is along a central axis “B.” The mounting portion **14** includes a central portion **40** and end portions **36**. Circumferential recesses **38** are defined on the mounting portion **14** for engagement with the handle **16** attached to the medical device **12**. The mounting portion **14** is not limited to such a configuration, however. For example, the central portion **40** may be a separate sleeve component that rotates around a pin, wherein the pin includes end portions **36**. Gaps between the sleeve and the end portions **36** would act as circumferential recesses **38** for engagement with the handle **16**.

The shaft **22** is flexible and generally cylindrical in shape, oriented along a central axis “A,” substantially perpendicular to the axis “B” of the mounting portion **14**. The shaft **22** is directly or indirectly coupled to the mounting portion **14**.

The shaft **22** is optionally located such that the mounting portion **14** is positioned at an end portion **24** of the shaft **22**. Alternatively, the end portion **24** of the shaft **22** is optionally spaced from the mounting portion **14**.

The shaft **22** has a cross-sectional area smaller than that of the hook portion **28**, and is sized to twist or deform or bend sufficiently for rotation of the hook portion **28** between the plane of axis “B” of the mounting portion **14** (the relaxed position of the hanger **10** shown in FIGS. 3A-3B) and a plane substantially perpendicular to axis “B” of the mounting portion **14** (the non-relaxed position of the hanger **10** shown in FIGS. 5 and 6).

The shape of the shaft **22** is not limited to a cylindrical shape or a round cross-sectional shape. For example, the cross-sectional shape may be square, triangular, or any other shape capable of twisting or otherwise deforming. Also, rotation of shaft **22** can be accomplished by forming shaft **22** or hanger **10** from multiple components coupled to one another in such a way to achieve rotation of the hook portion **28** with respect to the mounting portion **14**. For example, the hanger **10** is optionally formed from telescoping components, rotationally coupled components, or components joined for pivotal or rotational movement with respect to one another.

As stated previously herein, the hanger **10** is optionally molded from plastic. For example, the hanger **10** can be formed using an injection molding process. However, the hanger may be molded or otherwise formed from a variety of materials, so long as the hook portion **28** is sufficiently rigid to hang from a support **56A**, **56B**, and the shaft **22** is sufficiently flexible to twist or otherwise deform or rotate for rotation of the hook portion **28** with respect to the mounting portion **14**. For example, the hanger **10** may be molded from rubber, or formed from composite material.

FIGS. 4A-4D illustrate the handle **16** in greater detail. As mentioned previously herein, ornamental features of the handle **16** are illustrated in co-pending Design Patent Application No. 29/192,612, now U.S. Pat. No. D517,897. The

handle **16** includes a grasping portion **42** and an elongated groove **54**. The grasping portion **42** is provided with an ornamental curvature, and the elongated groove **54** is provided with an ornamental “U”, shaped cross-section. These ornamental features can be modified to provide a different ornamental appearance, depending upon design preferences, without impact on the use or operation of the handle **16**.

Notches **44** are defined in the handle **16** for engagement with the mounting portion **14** of each hanger **10**. More specifically, each circumferential recess **38** defined on a mounting portion **14** of a hanger **10** engages a notch **44** defined in the handle **16**. The central portion **40** of the mounting portion **14** is positioned within the ornamental elongated groove **54** between opposed walls of the handle **16**, and the end portions **36** are positioned on an outside surface of the grasping portion **42**, as illustrated in FIGS. 1, 2, 5, and 6.

The orientation of the central portion **40** combined with end portions **36** prevents axial movement of mounting portion **14** along the “B” axis (represented in FIG. 3A). The circumferential recesses **38** are engaged within the notches **44**, thereby facilitating pivotal movement “P” (represented in FIG. 3C).

As illustrated in FIGS. 4A and 4D, slots **52** are defined within the handle **16**. More specifically, the slots **52** are defined along a bottom surface of the ornamental elongated groove **54** of the ornamental grasping portion **42**. Such slots **52** are configured to accommodate at least a portion of each hook portion **28** when the hangers **10** are in their retracted or stowed positions (illustrated in FIG. 1). When in this stowed position, the hook portions **28** of hangers **10** are substantially protected so as to reduce the unintended hooking of hook portions **28** on objects adjacent to the medical device **12**, such as sheets, tubes, wires and other objects found in the health care environment.

It will be understood that such unintended hooking can be frustrating during use or set up of the medical device **12**. Medical devices such as the thoracic chest drain shown in the figures often need to be set up quickly and easily. By reducing the accessibility of hook portions **28** of hangers **10** when in the stowed position, the frustration associated with unintended hooking is reduced or eliminated.

FIGS. 4A-4C illustrate protrusions **46** extending from the handle **16**. Each protrusion **46** includes a flat projection **50** and a rib **48** provided to support the flat projection **50**. The protrusions **46** separate the hangers **10** from one another when the hangers **10** are in the retracted position shown in FIG. 1. The protrusions **46** also help to guide the hook portions **28** of hangers **10** into respective slots **52** as the hangers **10** are moved from their extended position (FIG. 2) to their retracted position (FIG. 1). This feature is helpful during the assembly of the medical device **12** for shipment and during the use of the medical device **12**.

The hangers **10** may initially be in their retracted position within the handle **16** as illustrated in FIG. 1. The protrusions **46** ensure the hangers **10** are properly aligned within the ornamental elongated groove **54** of the ornamental grasping portion **42** of the handle **16**. The slots **52** defined along a bottom surface of the ornamental elongated groove **54** accommodate at least a portion of each hook portion **28**, thereby permitting the hook portions **28** to lay flush within the grasping portion **42**. In other words, the hangers **10** in their retracted position do not substantially change the shape of the handle **16**, and do not interfere with a user’s ability to hold the grasping portion **42** to move the medical device **12** as desired. The hangers **10** are virtually hidden when in their retracted position.

In use, a user may pull up on each finger tab **30**, pivoting each hanger **10** to the deployed position illustrated in FIG. **2**. It is the orientation of the circumferential recesses **38** of the mounting portions **14** with respect to the handle **16** that facilitates the pivotal movement of the hangers **10** with respect to the handle **16**. In other words, the pivotal movement “P” of each mounting portion **14** (represented in FIG. **3C**) facilitates deployment or retraction (at this point, deployment) of each respective hanger **10** with respect to the handle **16**.

In the deployed position illustrated in FIG. **2**, each hanger **10** is oriented in a plane substantially perpendicular to axis “B” of each respective mounting portion **14** (the non-relaxed position of the hanger **10**). As described previously herein, each shaft **22** is flexible and generally cylindrical in shape, oriented along a central axis “A,” substantially perpendicular to the axis “B” of each respective mounting portion **14**. Each shaft **22** is sized to twist sufficiently for rotation of the hook portion **28** with respect to the mounting portion **14**.

At this point in the use of this assembly **20**, the user rotates each hook portion **28** from a plane substantially perpendicular to axis “B” of each respective mounting portion **14** (the non-relaxed position of the hanger **10**) to a plane substantially parallel to axis “B” (the relaxed position of the hanger **10**). More specifically, the hanger **10** is returned to its relaxed position, as illustrated in FIGS. **3A-3D**. The rotational movement, as represented by “R” in FIG. **3A**, rotates the hook portions **28** from the position illustrated in FIG. **2** to the position illustrated in FIG. **5**. Such rotational movement “R” of the shaft **22** facilitates the orientation of the hook portion **28** with respect to a support **56A, 56B**. The user may then engage the hook portions **28** of the hangers **10** to a support **56A, 56B**, thereby hanging the medical device **12**.

FIG. **5** illustrates a cylindrical support **56A**, while FIG. **6** illustrates a support **56B** with an aperture **58** from which the medical device **12** hangs. The shape of the support may vary. For example, the support may have a square cross-section, a rectangular cross-section, a triangular cross-section, or any other cross-section conducive to engagement with the hook portions **28** of the hangers **10**. Alternatively, the support may be a member that includes apertures or notches of various shapes and sizes, as long as these configurations are conducive to engagement with the hook portions **28** of the hangers **10**.

Also, the support may be oriented in a wide variety of positions and directions. For example, the support can be oriented along an axis that is substantially parallel to the face of the medical device **12** (as shown in FIG. **5**), substantially perpendicular to the face of the medical device **12**, or at any other angle. The support can be a rod, tube, or other structure found in a medical or surgical environment. The support can also be a knob, furniture component, or any other structure proximal to a patient that is capable of supporting the medical device.

Alternatively, the support may define an aperture such as aperture **58** of support **56B** through which one or more hook portions **28** can extend. The support may also define a recess or other configuration that provides a surface from which the medical device **12** can be hung.

The assembly illustrated in the figures is particularly well adapted for hanging a medical device from a wide variety of supports in a wide variety of configurations and orientations. Specifically, the hook portions **28** can be oriented in any number of planes. The hook portions **28** can also be faced in opposite directions to capture a support member. The hook portions **28** can also be positioned adjacent one another in a

plane substantially parallel to the face of the medical device **12**, in a plane substantially perpendicular to the face of the medical device **12**, or in a variety of planes. When positioned adjacent one another as shown in FIG. **6**, the hook portions **28** are configured to engage a substantially common point or location of a support (e.g., an aperture, a knob, etc.). The hook portions **28** can also be spaced from one another as shown in FIG. **5**.

When removal of the medical device **12** from a support **56A, 56B** is desired, the user may remove the hook portions **28** of the hangers **10** from the support **56A, 56B**. At this point in the use of this assembly **20**, the hangers **10** are oriented with respect to the handle **16** as illustrated in FIG. **5** (without the support **56A**) in their relaxed positions, i.e., each hook portion **28** resides in a plane of axis “B” of its respective mounting portion **14**.

The user may then rotate each hook portion **10** from a plane substantially parallel to axis “B” of each respective mounting portion **14** to a plane substantially perpendicular to axis “B.” Each shaft **22** twists or otherwise moves sufficiently for rotation of the hook portions **28**. In other words, the rotational movement, as represented by “R” in FIG. **3A**, rotates the hook portions **10** from the position illustrated in FIG. **5** to the position illustrated in FIG. **2**. Such rotational movement “R” of the shaft **22** facilitates the orientation of the hook portion **28** with respect to the handle **16**.

The hangers **10** are then pivoted toward the handle **16**. As explained previously herein, the pivotal movement “P” of each mounting portion **14** (represented in FIG. **3C**) facilitates deployment or retraction (at this point, retraction) of each respective hanger **10** with respect to the medical device **12**. As each hanger **10** is pivoted toward the grasping portion **42** of the handle **16**, the flat projection **50** of each protrusion **46** (illustrated in FIGS. **4A-4C**) guides each hook portion **28** for proper alignment with respect to one another. As explained previously herein, the protrusions **46** separate the hangers **10** from one another in their fully retracted (or stowed) positions.

As each hanger **10** is pivoted toward the grasping portion **42** of the handle **16**, at least a portion of each hook portion **28** passes through the slots **52** defined within the grasping portion **42**. As explained previously herein, the slots **52** are configured to accommodate at least a portion of each hook portion **28** when the hangers **10** are in their fully retracted positions, thereby permitting the hook portions **28** to lay substantially flush within the ornamental grasping portion **42** (as illustrated in FIG. **1**). The user may then hold the grasping portion **42** to move the medical device **12** as desired.

While preferred embodiments of the invention have been shown and described herein, it will be understood that such embodiments are provided by way of example only. Numerous variations, changes, and substitutions will occur to those skilled in the art without departing from the spirit of the invention. For example, the hook portion **28** of the hanger **10** is not limited to a rounded hook shape as illustrated in FIGS. **1, 2, 3A, 3B, 5, and 6**. Alternatively, the shape of hook portion **28** may include squared or angular interior corners.

Also, the hanger or hangers **10** can be mounted to the medical device **12** as opposed to being mounted to the handle **16**. For example, the hangers **10** could alternatively be mounted to surfaces of the medical device **12** such as the side surfaces of the medical device **12**. It has been discovered, however, that by mounting the hangers **10** to the handle **16** as opposed to the medical device **12**, it is possible to avoid the provision of mounting structures on surfaces of the

medical device **12**. Also, the hangers **10** can be stowed in the handle **16** without altering the structure of the medical device **12**. Additionally, mounting hangers **10** to the handle **16**, as opposed to the sides of the medical device **12**, avoids the increased width resulting from mounting structures extending from the sides of the medical device **12**.

Accordingly, it is intended that the appended claims cover all such variations as fall within the spirit and scope of the invention.

What is claimed is:

1. An apparatus for hanging a medical device, said apparatus comprising:

a shaft;

a mounting portion coupled to an end portion of said shaft and configured for mounting said apparatus for movement with respect to the medical device between a retracted position and a deployed position, wherein said mounting portion extends along a longitudinal axis and said longitudinal axis of said mounting portion is oriented perpendicular to an axis of said shaft, and wherein said mounting portion defines at least one circumferential recess positioned on an exterior cylindrical surface of said mounting portion to facilitate the movement of said apparatus with respect to the medical device; and

a hook portion positioned at an opposite end portion of said shaft and configured for hanging said apparatus from a support when said apparatus is in said deployed position, wherein said hook portion is positionable in a plane parallel to the longitudinal axis of said mounting portion;

wherein said shaft is configured to permit rotation of said hook portion with respect to said mounting portion, thereby facilitating orientation of said hook portion with respect to the support.

2. The apparatus of claim **1**, wherein at least one of said shaft, said mounting portion, and said hook portion is molded.

3. The apparatus of claim **1**, wherein said shaft is generally cylindrical in shape.

4. The apparatus of claim **1**, wherein said shaft has a cross-sectional area smaller than that of said hook portion.

5. The apparatus of claim **1**, wherein said shaft is flexible.

6. The apparatus of claim **1**, wherein said shaft is sized to twist sufficiently for rotation of said hook portion between said plane of said axis of said mounting portion and a plane substantially perpendicular to said axis of said mounting portion.

7. The apparatus of claim **1**, wherein the medical device is a fluid recovery system.

8. The apparatus of claim **7**, wherein the medical device is a thoracic cavity drainage system.

9. The apparatus of claim **1**, wherein said mounting portion is spaced from an end portion of said shaft.

10. An assembly configured to be hung from a support, said assembly comprising:

a thoracic cavity drainage system including a collection chamber for storing fluid and a handle for grasping by a user; and

at least one hanger coupled to said handle comprising an elongated shaft;

a mounting portion coupled to an end portion of said elongated shaft and coupled for pivotal movement with respect to said drainage system about a longitudinal axis of said mounting portion; and

a hook portion positioned at an opposite end portion of said elongated shaft and configured for hanging from the support;

wherein said elongated shaft of said hanger is configured to permit rotation of said hook portion with respect to said mounting portion of said hanger about a longitudinal axis of the elongated shaft, thereby facilitating orientation of said hook portion with respect to the support, and

wherein a slot is defined in said handle to accommodate at least a portion of said hook portion when said hanger is in a retracted position.

11. The assembly of claim **10** wherein said handle is integral to said drainage system.

12. The assembly of claim **11**, wherein said mounting portion pivots with respect to said handle, thereby facilitating deployment or retraction of said hanger with respect to said handle.

13. The assembly of claim **10**, wherein said hanger is stowed in said retracted position, thereby preventing unintentional hooking of said hook portion.

14. The assembly of claim **10**, wherein said assembly further comprises a plurality of hangers.

15. An assembly configured to be hung from a support, said assembly comprising:

a medical device; and

a plurality of hangers, each comprising a shaft;

a mounting portion coupled to an end portion of said shaft and coupled for pivotal movement with respect to said medical device;

a hook portion positioned at an opposite end portion of said shaft and configured for hanging from the support; wherein said shaft of each hanger is configured to permit rotation of said hook portion with respect to said mounting portion, thereby facilitating orientation of said hook portion of each hanger with respect to the support for positioning the medical device; and

wherein said hangers are pivotable with respect to said medical device, thereby facilitating deployment of said hangers with respect to said medical device to an extended position, and a surface of the medical device is positioned to contact said hook portions of said hangers in a retracted position of the hangers, thereby limiting movement of the hook portions of the hangers in the retracted position; and

wherein said hangers are positioned adjacent one another in said extended position for hanging from a substantially common point on said support.

16. The assembly of claim **15**, further comprising a handle coupled to said medical device.

17. The assembly of claim **16**, wherein said mounting portion pivots with respect to said handle.

18. An assembly configured to be hung from a support, said assembly comprising:

a thoracic cavity drainage system defining a collection chamber for storing fluid;

a handle coupled to said drainage system and configured for grasping said drainage system; and

at least one hanger comprising a flexible shaft;

a mounting portion having a longitudinal axis, said mounting portion being coupled to an end portion of said flexible shaft and coupled to said handle for pivotal movement only about said longitudinal axis; and

a hook portion positioned at an opposite end portion of said flexible shaft and configured for hanging from the support;

11

wherein said hanger is pivotable with respect to said handle, thereby facilitating deployment and retraction of said hanger with respect to said handle,

wherein said flexible shaft is configured to twist sufficiently to permit rotation of said hook portion with respect to said mounting portion about a longitudinal axis of said flexible shaft, thereby facilitating orientation of said hook portion of said hanger with respect to the support for positioning the drainage system.

19. An assembly configured to be hung from a support, said assembly comprising:

- a thoracic cavity drainage system;
- a handle coupled to said drainage system and configured for grasping said drainage system, said handle defining at least one aperture; and

12

at least one hanger comprising a shaft;

a mounting portion coupled to an end portion of said shaft and coupled to said handle; and

a hook portion positioned at an opposite end portion of said shaft and configured for hanging from the support;

wherein said hanger is pivotable with respect to said handle, thereby facilitating deployment and retraction of said hanger with respect to said handle; and

wherein at least a portion of said hook portion of said hanger extends into said aperture in said handle when said hanger is in a retracted position.

* * * * *