



US007229478B2

(12) **United States Patent**
Masini

(10) **Patent No.:** **US 7,229,478 B2**
(45) **Date of Patent:** **Jun. 12, 2007**

(54) **SHOULDER PROSTHESIS WITH ANATOMIC REATTACHMENT FEATURES**

4,404,692 A 9/1983 Eftekhar 623/23.26
4,501,263 A 2/1985 Harbuck 128/898

(75) Inventor: **Michael A. Masini**, Ann Arbor, MI (US)

(Continued)

(73) Assignee: **MedIdea, LLC**, Ann Arbor, MI (US)

OTHER PUBLICATIONS

(*) Notice: Subject to any disclaimer, the term of this patent is extended or adjusted under 35 U.S.C. 154(b) by 81 days.

Smith & Nephew Orthopaedic Catalog, showing the NEER 3 total shoulder, prepared Oct. 2003.

(Continued)

(21) Appl. No.: **10/996,415**

Primary Examiner—Suzette Gherbi

(22) Filed: **Nov. 23, 2004**

(74) *Attorney, Agent, or Firm*—Gifford, Krass, Sprinkle, Anderson & Citkowski, PC

(65) **Prior Publication Data**

(57) **ABSTRACT**

US 2005/0090832 A1 Apr. 28, 2005

Related U.S. Application Data

(63) Continuation of application No. 10/091,846, filed on Mar. 6, 2002, now Pat. No. 6,821,300, which is a continuation of application No. 09/396,576, filed on Sep. 15, 1999, now Pat. No. 6,379,391, which is a continuation of application No. 09/029,457, filed as application No. PCT/US97/01754 on Jan. 31, 1997, now Pat. No. 6,267,785.

Apparatus and methods are disposed for maintaining the proper positioning of a prosthetic implant having proximal and distal ends within a prepared bone cavity during cement injection and curing. First stabilization means, implantable within the bone cavity, minimize lateral movement of the distal end of the implant, while second stabilization means, physically separate from the means for minimizing lateral movement of the distal end of the implant, minimize both the lateral movement of the proximal end of the implant and the rotational movement of the implant overall. In the preferred embodiment, the second stabilization means includes an apertured cap removably securable to the end of a bone having the prepared cavity through which the implant is inserted and held in place. This cap, which may either be entirely rigid or include a pliable membrane in the vicinity of the aperture, preferably further includes a first port associated with cement injection and a second port associated with cement over-pressurization. In an alternative embodiment, the second stabilization means includes a manually operated mechanism enabling the implant to be temporarily yet rigidly secured thereto in accordance with a desired orientation, preferably affording adjustments along multiple degrees of freedom prior to the rigid securement thereof.

(51) **Int. Cl.**
A61F 2/40 (2006.01)

(52) **U.S. Cl.** **623/19.11**; 623/19.14;
623/23.19; 623/23.21

(58) **Field of Classification Search** .. 623/19.11–19.14,
623/23.19–23.23

See application file for complete search history.

(56) **References Cited**

U.S. PATENT DOCUMENTS

3,067,740 A 12/1962 Haboush 128/92
4,030,143 A * 6/1977 Elloy et al. 623/19.12
4,274,163 A 6/1981 Malcom et al. 3/1.91
4,337,773 A 7/1982 Raftopoulos et al. 128/305
4,357,716 A 11/1982 Brown 3/1.913

4 Claims, 5 Drawing Sheets

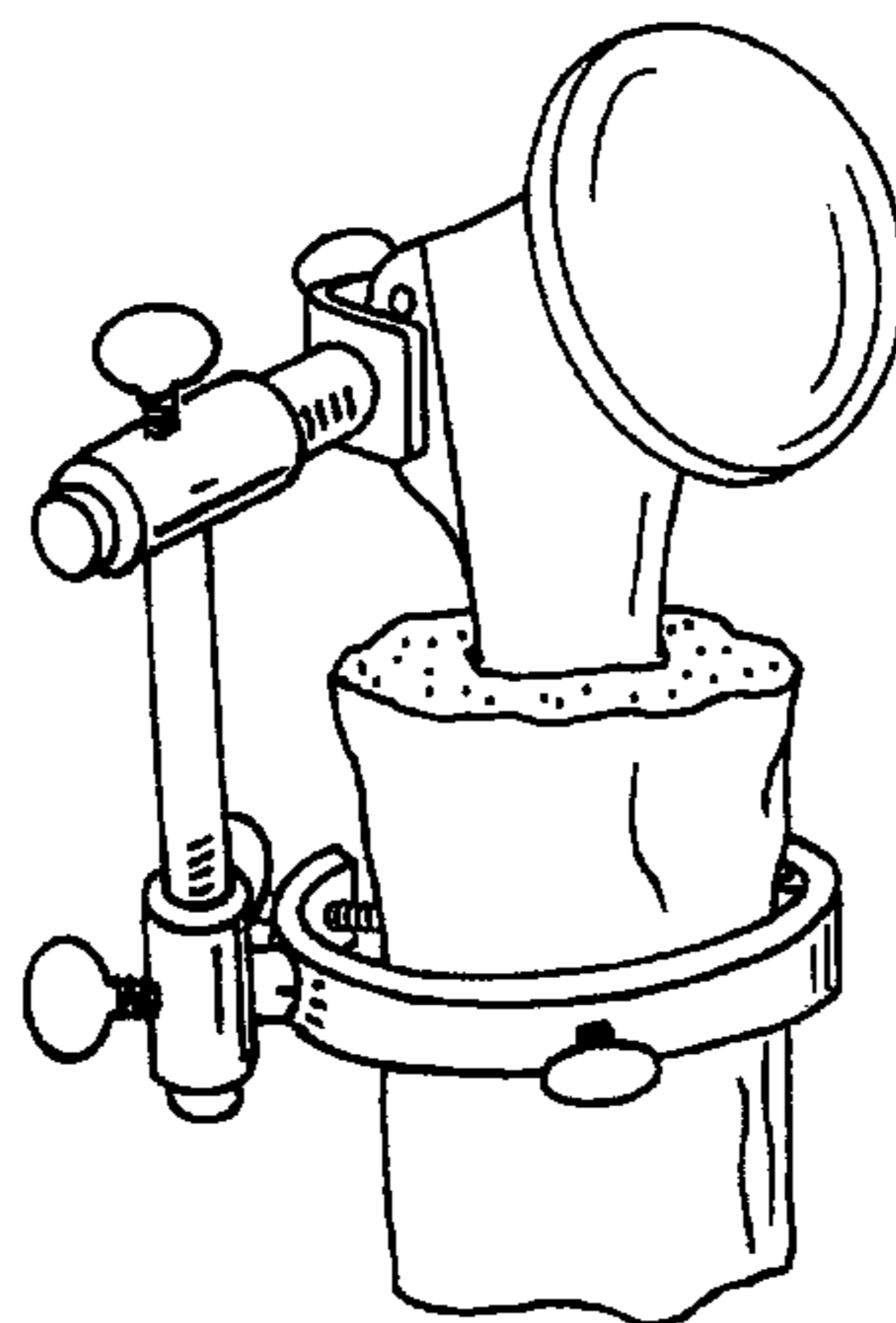

U.S. PATENT DOCUMENTS

4,560,374 A	12/1985	Hammerslag	604/509	5,554,192 A	9/1996	Crowninshield	623/23.26
4,577,631 A	3/1986	Kreamer	606/108	5,578,072 A	11/1996	Barone	623/1.13
4,641,653 A	2/1987	Rockey	606/194	5,628,783 A	5/1997	Quiachon	623/1.35
4,686,973 A	8/1987	Frisch	128/92	5,658,350 A	8/1997	Carbone	623/23.25
4,697,584 A	10/1987	Haynes	128/92	5,658,351 A	8/1997	Dudasik et al.	623/23.25
4,815,454 A	3/1989	Dozier, Jr.	128/92	5,683,472 A	11/1997	O'Neil et al.	623/20
4,896,662 A	1/1990	Noble	606/94	5,746,771 A	5/1998	Clement, Jr.	623/23.22
4,959,066 A	9/1990	Dunn et al.	606/89	5,766,261 A	6/1998	Neal et al.	623/16
4,983,183 A	1/1991	Horowitz	623/23	5,766,262 A	6/1998	Mikhail	623/23.25
4,994,071 A	2/1991	MacGregor	606/194	5,910,171 A *	6/1999	Kummer et al.	623/18.11
4,994,085 A	2/1991	Sawai et al.	623/23	5,910,172 A	6/1999	Penenberg	623/23.26
5,002,581 A *	3/1991	Paxson et al.	623/22.44	5,951,606 A	9/1999	Burke	623/23.26
5,047,050 A	9/1991	Arpesani	623/1.34	6,010,535 A	1/2000	Shah	623/22.16
5,047,061 A *	9/1991	Brown	623/23.2	6,102,953 A *	8/2000	Huebner	623/19.11
5,078,746 A	1/1992	Garner	623/23.26	6,126,691 A	10/2000	Kasra et al.	623/23.26
5,080,680 A	1/1992	Mikhail et al.	623/23.25	6,174,335 B1 *	1/2001	Varieur et al.	623/22.12
5,090,959 A	2/1992	Samson et al.	600/116	6,251,141 B1	6/2001	Pierson, III et al.	623/23.48
5,092,892 A	3/1992	Ashby	623/23.25	6,267,785 B1 *	7/2001	Masini	623/23.22
5,207,695 A	5/1993	Trout, III	623/1.36	6,371,991 B1 *	4/2002	Manasas et al.	623/22.12
5,219,355 A	6/1993	Parodi et al.	606/191	6,379,391 B1 *	4/2002	Masini	623/23.2
5,275,622 A	1/1994	Lazarus et al.	623/1.11	6,821,300 B2 *	11/2004	Masini	623/23.2
5,340,362 A	8/1994	Carbone	623/23				
5,360,443 A	11/1994	Barone et al.	623/1.13				
5,387,235 A	2/1995	Chuter	623/1.11				
5,456,717 A	10/1995	Zweymuller et al.	623/8				
5,501,687 A	3/1996	Willert et al.	606/94				
5,507,831 A	4/1996	Burke	623/23.26				

OTHER PUBLICATIONS

Biomet Orthopedics, Inc. Comprehensive Fracture Stem, © 2003.
 Acumed Polaris Modular Shoulder System Brochures, © 2002.
 Photograph of a Johnson & Johnson Proximal Femoral Endoprosthesis with "Z" logo, date unknown.

* cited by examiner

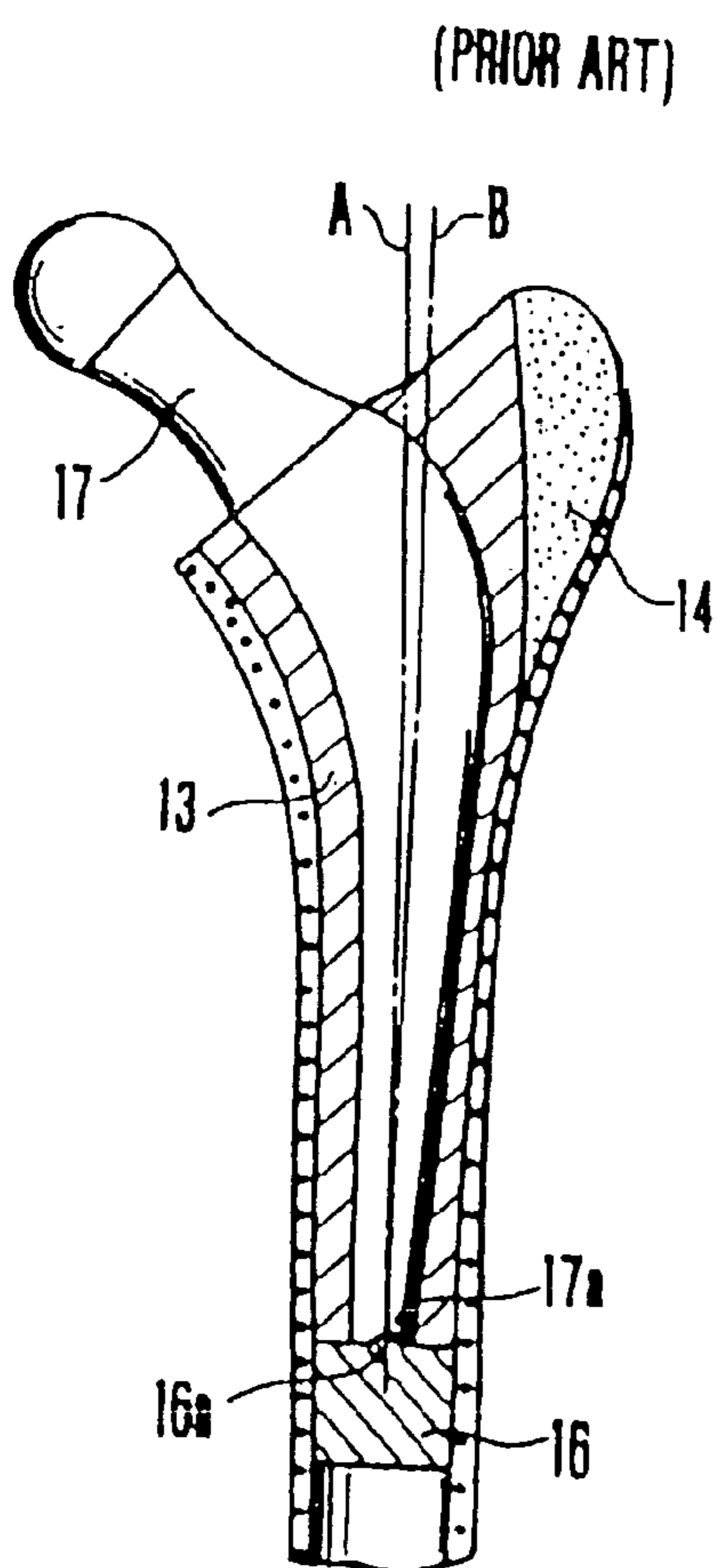
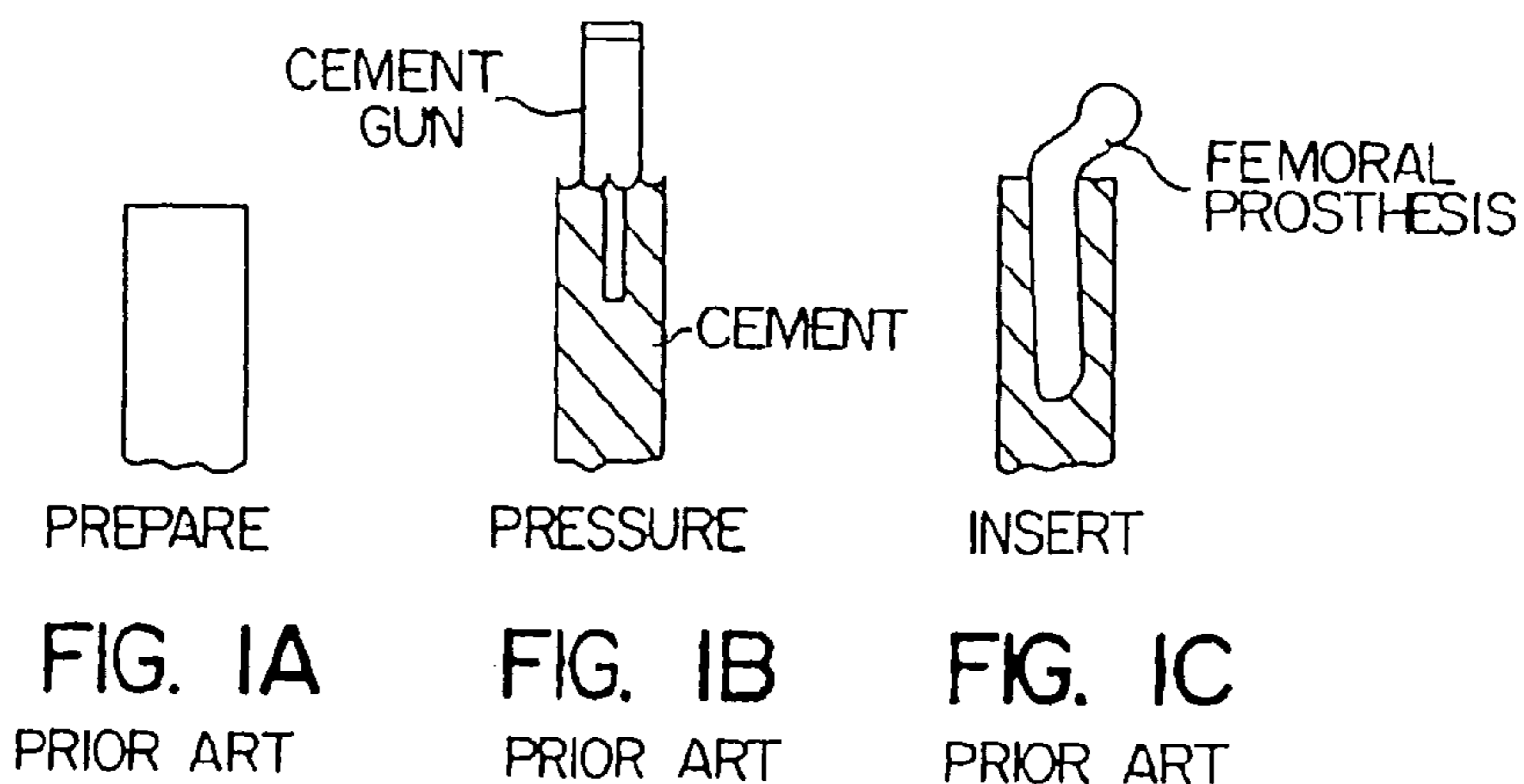

FIG-2A

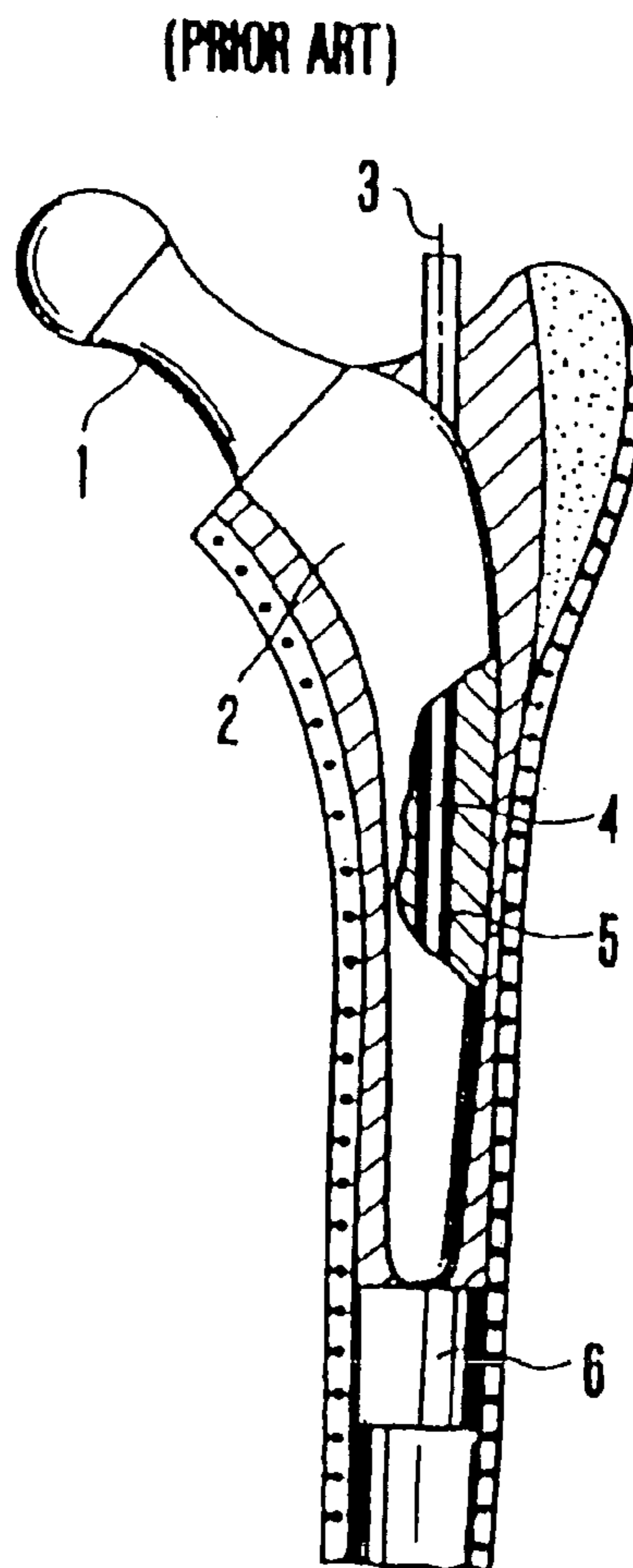

FIG-2B

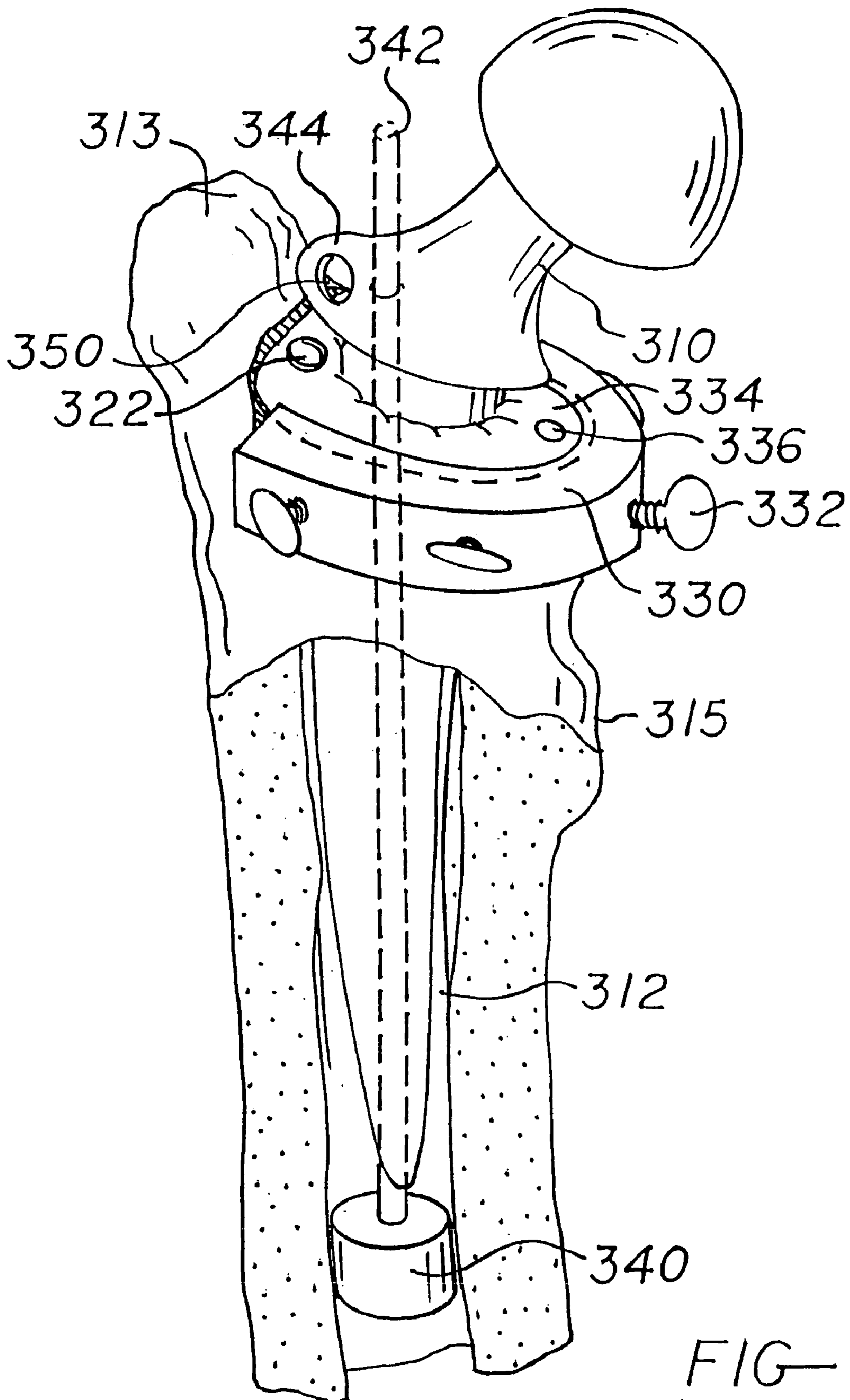

FIG-3

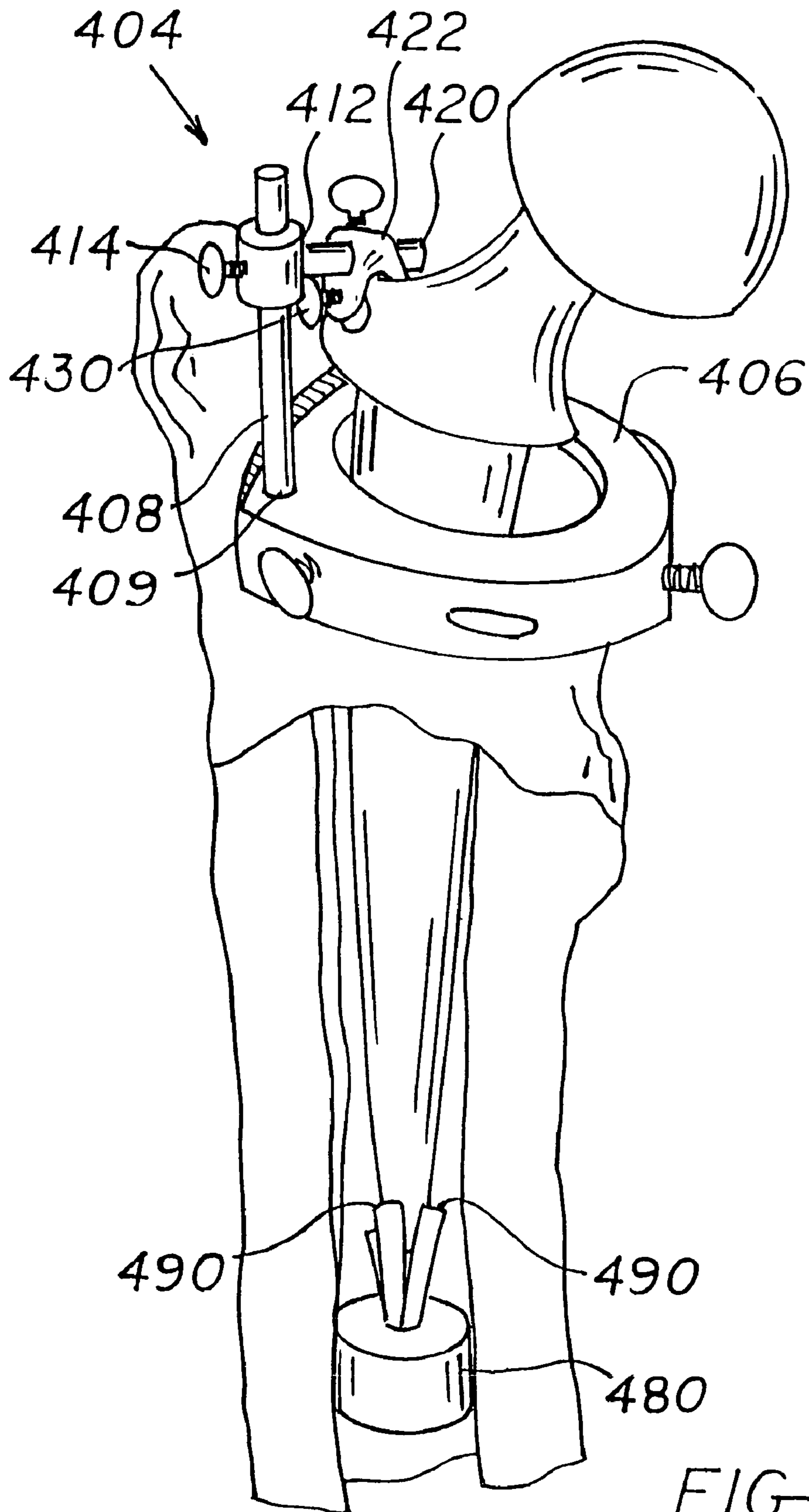
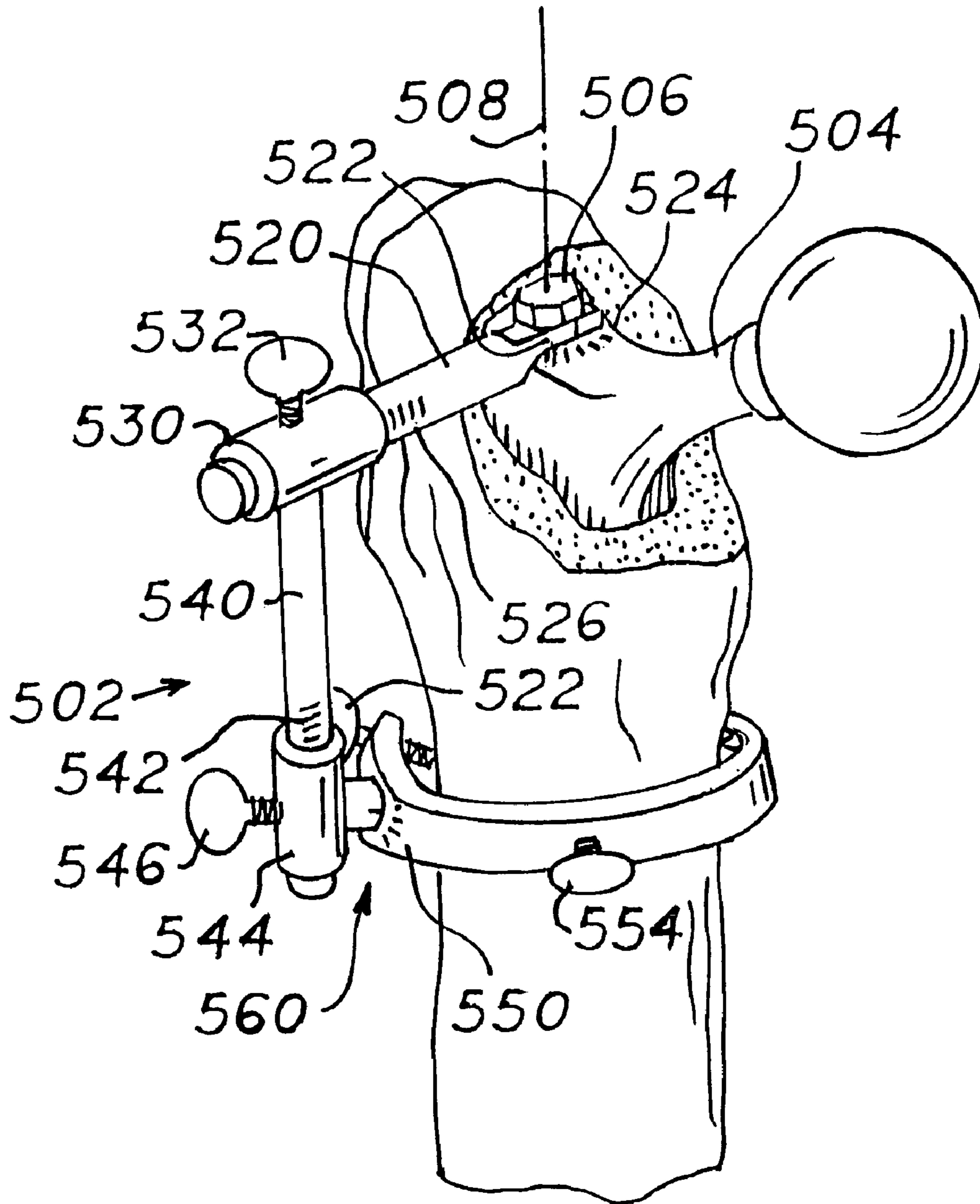

FIG-4



FIG—5

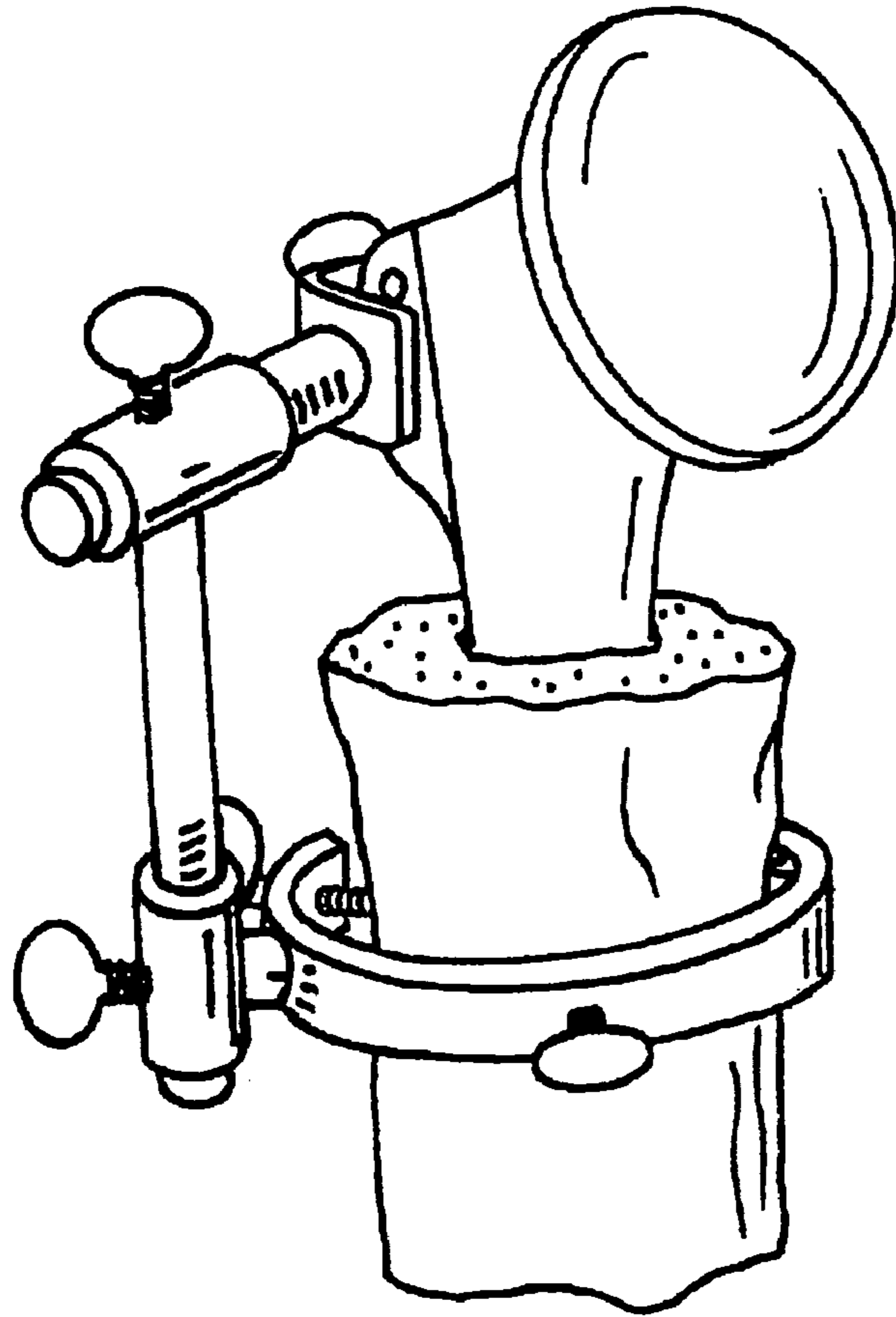

Fig - 6

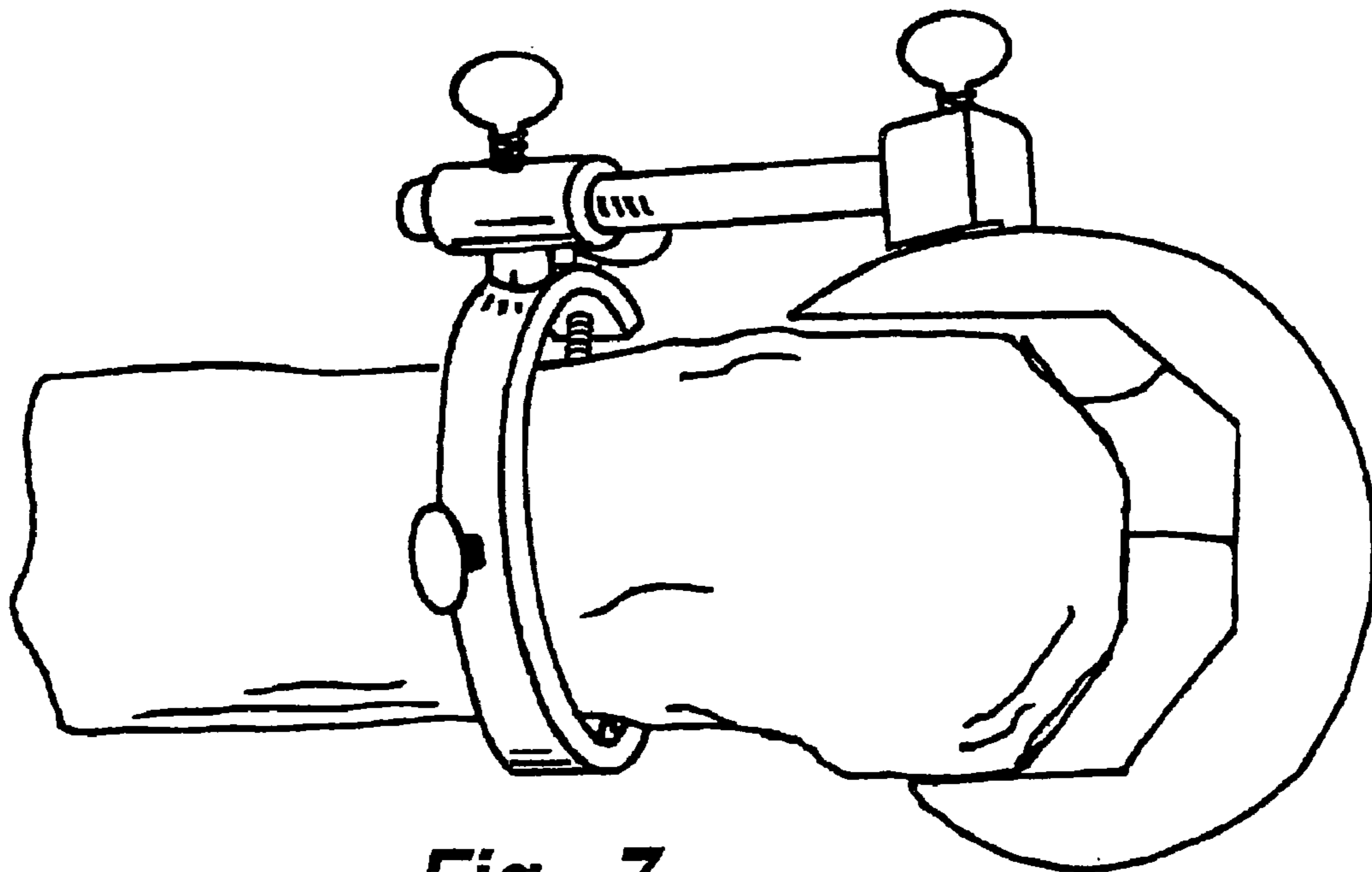

Fig - 7

SHOULDER PROSTHESIS WITH ANATOMIC REATTACHMENT FEATURES

REFERENCE TO RELATED APPLICATIONS

This is a continuation application of U.S. patent application Ser. No. 10/091,846, filed Mar. 6, 2002, now U.S. Pat. No. 6,821,300 which is a continuation of U.S. patent application Ser. No. 09/396,576, filed Sep. 15, 1999, now U.S. Pat. No. 6,379,391, which is a continuation of U.S. patent application Ser. No. 09/029,457, filed Mar. 5, 1998, now U.S. Pat. No. 6,267,785, which is a U.S. national phase application of Patent Cooperation Treaty application Ser. No. US97/01754, filed Jan. 31, 1997, which claims priority of U.S. patent application Ser. No. 08/595,277, filed Feb. 2, 1996, now abandoned. The entire contents of each application is incorporated herein by reference.

FIELD OF THE INVENTION

This invention relates generally to arthroplasty and, more particularly to devices and techniques for positioning a prosthesis prior to fixation through the injection of a bonding agent.

BACKGROUND OF THE INVENTION

In current joint repair situations, it is common practice to prepare host bone stock to receive an implant then, if satisfied with the physical correspondence, apply cement to the host, install the prosthesis, and stabilize the arrangement until curing. This approach has several disadvantages. Foremost among them arises from the unpredictable process of ensuring that, although the prosthesis may have been ideally placed prior to cementation, once the cement is applied, orientation may shift, resulting in a final configuration which is less than optimal.

A few approaches have been attempted to assist in making the positioning of the final implant more predictable. As discussed further in the detailed description herein, one such approach utilizes a centralizing plug inserted distally within the medullary canal, and from which there extends a rod upon which a final implant including a corresponding central bore may be monorailed. The plug and rod are positioned in conjunction with a trial which also includes a central bore, which is then removed, the intramedullary cavity filled with cement and the final implant slid over the rod, displacing the cement as it is pushed down into position. Although this technique may assist in maintaining a side-to-side orientation prior to cementation, it does not address the simultaneous need for up-and-down and/or rotational stabilization. Additionally, as with current techniques, cement is applied to the host prior to the introduction of the final implant, leaving open the possibility that the final implant may be held in a position different from that associated with the trial, and may therefore result in an unacceptable misplacement as the cement cures.

Other approaches do reverse this order, and install the final implant prior to the injection of cement. The known approaches, however, utilize a highly specialized prosthetic device including centralizing protrusions and internal channels through which the cement is introduced. That is, in these systems, the prosthesis itself is used as the cement injector. Due to their requirement for a highly specialized final prosthetic element, such systems are incompatible with currently available implant devices, and therefore raise costs while reducing the options of the practitioner. In addition,

they do not adequately address the need for simultaneously stabilizing multiple degrees of freedom prior and during cementation. As a further disadvantage, the systems which use the prosthesis as the cement injector tend to use the cement as a grout between the outer surface of the implant and the inner surface of the receiving cavity. It has been shown, however, that the changes of success are improved through the creation of a thicker cement "mantle," as opposed to a thin grout-type layer. The need remains, then, for a system whereby the prosthesis may be stabilized relative to multiple degrees of freedom prior to cementation, and, ideally, remain compatible with existing prosthetic components while forming a strong and stable bond to the host.

SUMMARY OF THE INVENTION

The present invention resides in apparatus and methods for maintaining the proper positioning of a prosthetic implant having proximal and distal ends within a prepared bone cavity during cement injection and curing. In contrast to prior-art systems the invention provides first stabilization means, implantable within the bone cavity, for minimizing lateral movement of the distal end of the implant, and second stabilization means, physically separate from the means for minimizing lateral movement of the distal end of the implant, for minimizing both the lateral movement of the proximal end of the implant and the rotational movement of the implant overall. In the preferred embodiment, the second stabilization means includes an apertured cap removably securable to the end of a bone having the prepared cavity through which the implant is inserted and held in place. This cap, which may either be entirely rigid or include a pliable membrane in the vicinity of the aperture, preferably further includes a first port associated with cement injection and a second port associated with cement over-pressurization. In an alternative embodiment, the second stabilization means includes a manually operated mechanism enabling the implant to be temporarily yet rigidly secured thereto in accordance with a desired orientation, preferably affording adjustments along multiple degrees of freedom prior to the rigid securement thereof.

BRIEF DESCRIPTION OF THE DRAWINGS

FIG. 1A illustrates, in skeletal form, the first step of a prior-art implantation sequence involving host bed preparation;

FIG. 1B depicts an intermediate step in the prior-art sequence wherein the cavity prepared according to FIG. 1A is filled with cement;

FIG. 1C illustrates the final phase of this prior-art sequence wherein a femoral prosthesis is inserted into the injected cement prior to hardening;

FIG. 2A illustrates a prior-art improvement over the sequence shown in FIGS. 1A through 1C, wherein a distal plug is used for distal centering of the implant;

FIG. 2B illustrates yet another prior-art improvement over the approach of FIG. 2A wherein a vertically oriented rod is attached to the distal plug over which an implant may be slid after cement injection to further inhibit movement during curing;

FIG. 3 is an arrangement according to this invention showing the use of a proximal cap which may be used either with a specially prepared prosthetic device or commercially available unit;

FIG. 4 illustrates two independently usable alternative embodiments according to the invention, including a multiple degree-of-freedom proximal retainment structure and a distal plug including leaf springs;

FIG. 5 is a drawing which shows, from an oblique perspective, an alternative embodiment of the invention which clamps around the femur below the area of resection, and attaches to an elongated fastener oriented generally lengthwise with respect to the implant;

FIG. 6 is a drawing which shows how the invention could be applied to a humeral prosthesis; and

FIG. 7 is a drawing which shows how the invention may be applied to knee arthroplasty.

DETAILED DESCRIPTION OF THE PREFERRED EMBODIMENTS

FIG. 1 of U.S. Pat. No. 5,340,362 shows an existing, prior-art procedure for inserting and cementing a prosthesis into a bone cavity, and this figure has been reproduced herein. In accordance with this technique, the canal is reamed or broached as shown in FIG. 1A, and a trial is typically inserted thereinto to ensure that the final prosthetic component will be properly received. After this trialing, cement is injected into the excavated area as shown in FIG. 1B, and the prosthesis is inserted as shown in FIG. 1C, and left in position while the cement hardens. As discussed in the background of the instant invention, the technique just described is deficient in that, although the prosthesis may be optimally oriented during the trial procedure, the position of the actual implant may shift upon insertion into the cemented host or thereafter, resulting in a misaligned final fixation.

Various improvements also exist in the prior art to minimize such adjustment problems. At the very least, as shown in FIG. 6 of U.S. Pat. No. 4,994,085, reproduced herein as FIG. 2A, a distal centralizer 16 is inserted beforehand into the intramedullary cavity 13 to which the distal tip 17a of the implant 17 engages at point 16a. This, at least, stabilizes the relative position of the distal tip 17a, resulting in a narrower range of angles (A to B) through which the implant 17 may move within the cement-filled cavity prior to final curing. The teachings of this reference further improve upon post-cementation stabilization by incorporating a stabilizing rod 4 into the distal plug 6 over which a specially designed implant 2 having a centralized hole 4 is slidably installed, as shown in FIG. 2B herein (FIG. 4 of the issued patent). Assuming the various connections between rod 5, plug 6 and the inner walls of the intermedullary canal are relatively rigid, and the various tolerances involved are substantially tight, movement of the implant 2 is further restricted until the cement finally cures.

Another approach taken according to the prior art involves the injection of cement after positioning of a specially designed implant into a prepared cavity. The '362 patent referenced above is directed toward such an approach. As with other arrangements of type, the final implant includes a cement canal along its longitudinal axis. A bone-cement injector is threaded onto the proximal portion of this cement canal, causing the cement to subsequently travel down and through the implant, eventually exiting through openings in and around its distal tip. A restrictor plug halts downward cement travel, thus initiating an upward, retrograde filling of the void in between the prosthesis and the cancellous bone wall. In addition to a single distal aperture through which the injected cement is intro-

duced, side ports may also be included, as shown in U.S. Pat. No. 4,274,163 and various other prior-art references.

The methods and associated apparatus just described exhibit various shortcomings. In the technique described with reference to FIG. 2B herein, although movements within the curing cement bed are further restricted, the point of substantial stability remains at the distal tip of the implant, enabling a certain level of proximal misalignment to continue, as no true proximal stabilization is provided. Worse, perhaps, is that since the centering rod and bore through the specialized component are both circular, the final implant is still subject to up-and-down and/or rotational variation, resulting in potential misalignment upon fixation.

With respect to the techniques wherein cement is injected after installation, although the implant may be stabilized both proximally and distally as the cement is injected, as with the device of the '085 patent, a specially designed implant including the injector ports must be utilized, resulting in a specialized unit demanding significantly higher cost. Furthermore, regardless of the existing system utilized, attention to the pressure of the cement during injection and curing has not been adequately addressed. Although, for example, the system described in the '163 patent referenced above utilizes various components to maintain pressurization, numerous sophisticated articles are required, including a high pressure nitrogen gas source, disposable cylinder and various associated valves and tubing which may be difficult to assemble, require skilled operators, or create expensive waste and maintenance problems.

The present invention improves upon the prior art by providing a simplified apparatus and associated installation methods whereby an implant may be oriented both proximally and distally prior to the injection of cement, while, at the same time, providing means for guarding against rotational and up/down movement of the implant as well during such injection and subsequent curing. In addition, configurations according to the invention provide a simple means for expelling over-pressurized cement, thereby yielding a simple, but satisfactory indication that sufficient cement has been injected to an acceptable level. Although, in one embodiment, the invention makes advantageous use of a longitudinal bore through the implant, in another embodiment, all of the above improvements and advantages are realized in conjunction with standard, currently available prostheses, thus resulting in an approach which is both straightforward and economical.

FIG. 3 is an oblique drawing of an arrangement according to this invention depicting various independent embodiments. Overall, an implant 310 is shown inserted into a prepared cavity 312, in this case the implant 310 being a femoral hip prosthesis and the cavity 312 being the intramedullary canal, though, as will be apparent to those of skill in the art of orthopedics, the general principles disclosed herein are not restricted to this application, and may be used in other joint situations, including the knee, shoulder and other situations. Certain features of the femur are shown such as the greater trochanter 313 and lesser trochanter 315, and it is assumed that a resection not visible in this figure has been performed on at least a portion of the proximal end of the femur along with reaming and other preparation of the medullary canal itself to accept the implant 310.

Broadly, according to the invention, an apertured proximal sealing cap is installed over the resection portion of the femoral shaft, the prosthesis 310 is inserted through the proximal opening 320 of the seal, and cement is injected through an injection port 322. In a preferred embodiment, this proximal seal includes a horseshoe-shaped collar 330

having one or more means such as thumb screws **332** for releasably securing the collar **330** over the bone, and a preferably pliable gasket **334** made from rubber or other suitable polymeric materials through which the aperture **320** is formed. Also located on and through this gasket **334** is a flap valve **336** wherein the material forming the gasket **334** is adjusted to flap open or rupture at a predetermined pressure level, preferably on the order of 25 mm of mercury, which has shown to be advantageous for such orthopedic purposes. Preferably, this flap valve **336** is formed either by scoring the material of the gasket **334** in a manner conducive to such rupture, or, alternatively, the material may be thinned in this area to break under load.

The embodiment of the proximal seal just described is that preferred for use in conjunction with standard, commercially available implants. That is, the aperture **320** formed in the gasket **334** may take the form of a slit, an oval, or another shape appropriate to the stem of the implant, enabling the device to be inserted therethrough and retained in place by the surrounding material of the gasket **334** against the stem, either through friction or high-tolerance. Alternatively, then, if a more precise geometry of the stem at the point where it emerges through the proximal seal is known, the material **334** may be of a more rigid composition, and may, in fact, be integrally formed to the collar **330**, in which case the injection port **322** and valve **336** may be more elaborate and substantial. For example, if the area **334** is metal, the port **322** may be threaded for a more solid connection to commercially available injector nozzles, and the valve **336** may take advantage of more sophisticated pressure-release techniques available in the art, including adjustability for a particular pressure or range of pressures.

Whether the implant is of a standard configuration or specialized for use in conjunction with the invention, a distal spacer **340** is preferably utilized for distal centering. A longitudinal rod **342** may optionally be added to, or installed on the plug **340**, requiring a specialized implant having a longitudinal bore **344** akin to that described in the '085 patent referred to above, the exception being that, according to this invention, the implant **310** would be monorailed onto the optional rod **342** prior to the injection of cement into the cavity formed between the walls of the implant and the prepared medullary canal. Thus, as discussed above, the present invention may either be used with a specially prepared implant having this longitudinal bore and/or convenient wall geometries or, alternatively, and unlike the prior art, a standard prosthesis may be used.

In the event that the prosthesis includes an arrangement to assist in installation or removal such as ring **350**, the alternative proximal stabilization configuration of FIG. 4 may be used. To further assist in proximal securement, a multiple degree-of-freedom clamp arrangement illustrated generally at **404** may be attached to a proximal cover **406** secured to femoral end or attached to a portion of available bone material by whatever means. In the embodiment shown, a first rod **408** securely affixed to the member **406** at point **409**, onto which there is disposed a slidable collar **412** which may be locked into position with a suitable device such as thumb screw **414**. A second rod **420** and collar **422** contains two thumb screws, one to lock the collar **422** in position along rod **420**, and a different thumb screw **430** for positive engagement with the prosthesis proper. It will be understood to those of skill that various other approaches may be utilized in accordance with the general principle contained herein to grasp and hold any portion or aperture of a standard implant without requiring its modification.

FIG. 4 also shows an alternative distal plug according to the invention which may be used in combination with any of the embodiments previously described. With such an inventive plug, it is first seated distally at an appropriate distance within the intermedullary canal, and includes a plurality of deformable upwardly oriented leaf springs **490**. Accordingly, with the plug **480** installed in place as shown, an even more generalized type of implant, and not requiring an actual, solid connection to such a distal spacer, may be inserted down and into the medullary canal and held in place while resisting distal side-to-side motion as the distal tip of the implant is retained within these leaf springs **490**. This also allows adjustments in a longitudinal direction enabling fine tuning at the effective length of the implant. Note in FIG. 4 that the aperture through which the implant is inserted does not include a seal per se. This is due to the fact that, in accordance with this embodiment, cement may, in fact, be injected prior to or after the implant is held in place both proximally and distally. Indeed, according to this particular embodiment, a standard distal plug may be used in conjunction with the mechanism shown generally at **404** even without a cap or collar as shown. For example, this mechanism **404** may simply attach to an existing bone surface or structure instead of the point **409**, thereby holding the implant in place proximally and distally while preventing motion in all dimensions as the cement cures, regardless of when it was injected. In accordance with an alternative methodology, the proximal and distal stabilizers may be used in conjunction with a trial then, upon achieving a desired orientation, a single manual fastener may be loosened, and the actual implant installed in the exact configuration of the trial to guarantee proper positioning.

FIG. 5 illustrates an alternative embodiment of the invention, seen generally at **502** from an oblique perspective. In this case, a prosthesis **504**, which may have a threaded bore along an axis **508** to receive a threaded fastener such as a bolt **506**, is physically coupled to a first structural element **520** which slidably engages with a collar **530**, and which may be tightened in place with a manual fastener such as thumb screw **532**. Other types of fasteners, including those requiring tools such as set screws, may alternatively be utilized for this purpose. In this embodiment, the prosthesis **504** may be rotated about the axis **508** with the bolt **506** in a slightly loosened condition, and then tightened when a desired angular rotation is achieved. A score mark **522** may be used in conjunction with score marks **524** to provide an indication of this desired angular rotation for future reference. Preferably, score marks are provided on the underside of member **520** as well in the vicinity of the attachment to the prosthesis, to assist in maintaining the desired rotational configuration once the bolt **506** is tightened. Prosthetic devices having a threaded bore along axis **508** are available from the Zimmer Company, though in the event that such a feature is not provided for, connection may be made to the prosthetic element itself as disclosed elsewhere herein, rendering this threaded bore convenient but not necessary to the invention.

Preferably in this embodiment a set of score marks **526** are also provided on the member **520**, such that with the member **520** being moved back and forth to adjust the lateral or transverse positioning of the implant, the fastener **532** may be used to lock the configuration in place, with the marks **526** being used to maintain a visual indication of the desired lateral configuration. Attached to collar **530** is a downwardly extending member **540**, which is received by a collar **544** having a manual adjustment device **546**. The member **540** may also include markings **542**, such that, as

the element **540** is moved up and down to adjust for the axial length of the prosthesis, fastener **546** may be locked with the score marks **542** providing a visual indication.

The collar **544** is attached to a clamp **550**, which is rigidly attached to the outer surface of the femur through manual fasteners **552** and **554**. As a further optional convenience, the collar **544** may be rotationally variable, and locked into place along with member **540** with manual fastener **546**, with optional score marks **560** being used as a visual indication of this configuration, if so desired.

Although the various embodiments of this invention may be used to properly position a trial implant prior to the positioning of a final prosthetic element, it should be apparent that in all cases, the device such as **504** in FIG. **5** is assumed to be the final implant itself, thereby eliminating the need for a trial. Particularly if the various positioning elements of the invention are sufficiently low in profile, the entire assembly, including those shown in the figures, joint reduction may be carried out, with the various fasteners being adjustably and rigidly clamped, with the final implant positioned in place and rigidly connected thereto. Following this procedure, the properly positioned implant may be removed from its reduced configuration and cemented. According to the invention, depending upon the circumstances, the prosthesis may be cemented in situ, with the various positioning members according to the invention remaining locked in place, or, alternatively, one or more of the fasteners may be loosened, with the implant and, perhaps, other fasteners attached thereto, removed and repositioned once cement has been injected into the intramedullary canal.

For example, referring to the embodiment of FIG. **5**, fastener **546** may be slightly loosened, with the prosthesis **504** and members **520** and **540** rigidly attached thereto being

temporarily removed, the cavity filled with cement, and the prosthesis with members **520** and **540** reinserted, with member **540** being reinstalled into collar **544**, utilizing the score marks **542** to ensure that fixation will take place at a proper and desired orientation upon re-tightening of the fastener **546**. It will also be apparent that in the embodiment of FIG. **5** and others disclosed herein, that if the assembly attached to the femur and to the prosthetic element through using one or more structural elements according to the invention is sufficiently rigid, positioning of the final implant may be stabilized in three dimensions (for example, rotationally, transversely, and axially—i.e., with respect to the coronal, sagittal and transverse planes).

I claim:

1. A method of positioning a shoulder implant to achieve a desired orientation for cementation within an intramedullary canal of a humerus having an outer cortex, the method comprising the steps of:

providing a shoulder prosthesis having an articulating joint surface corresponding to a proximal humerus and an intramedullary stem;

positioning the intramedullary stem within an intramedullary canal; and

adjusting the orientation of the prosthesis by referring to a plurality of score marks corresponding to the orientation.

2. The method of claim **1**, wherein the score marks indicate the rotational orientation of the prosthesis.

3. The method of claim **1**, wherein the score marks indicate the depth of the prosthesis.

4. The method of claim **1**, wherein the score marks indicate the lateral or transverse orientation of the prosthesis.

* * * * *