



US007200145B1

(12) **United States Patent**
Edsall et al.

(10) **Patent No.:** **US 7,200,145 B1**
(45) **Date of Patent:** ***Apr. 3, 2007**

(54) **PRIVATE VLANS**

(75) Inventors: **Thomas J. Edsall**, Cupertino, CA (US);
Marco Foschiano, San Jose, CA (US);
Michael Fine, San Francisco, CA (US);
Thomas Nosella, Sunnyvale, CA (US)

(73) Assignee: **Cisco Technology, Inc.**, San Jose, CA (US)

(*) Notice: Subject to any disclaimer, the term of this patent is extended or adjusted under 35 U.S.C. 154(b) by 302 days.

This patent is subject to a terminal disclaimer.

(21) Appl. No.: **10/840,212**

(22) Filed: **May 5, 2004**

(51) **Int. Cl.**
H04L 12/56 (2006.01)

(52) **U.S. Cl.** **370/389; 370/401; 709/225**

(58) **Field of Classification Search** **370/389, 370/392, 401, 464, 465; 709/218, 221, 225**
See application file for complete search history.

(56) **References Cited**

U.S. PATENT DOCUMENTS

5,959,989 A	9/1999	Gleeson et al.
6,058,429 A	5/2000	Ames et al.
6,111,876 A	8/2000	Frantz et al.
6,147,995 A	11/2000	Dobbins et al.
6,208,649 B1	3/2001	Kloth
6,304,901 B1	10/2001	McCloghrie et al.
6,560,236 B1	5/2003	Varghese et al.

OTHER PUBLICATIONS

Tanenbaum, Andrew, Computer Networks, Third Edition, Prentice Hall, 1996, pp. 417-419.

Primary Examiner—Huy D. Vu
Assistant Examiner—Toan Nguyen

(74) *Attorney, Agent, or Firm*—Cesari and McKenna LLP

(57) **ABSTRACT**

The invention uses a layer 2 switch (L2 switch), or bridge, to separate user's message traffic by use of Virtual Local Area Networks (VLANs) defined within the switch. Three new types of ports are defined, "promiscuous" ports "isolated" ports, and "community" ports. Three types of VLANs internal to the switch are defined, "primary" VLANs, "isolated" VLANs and "community" VLANs. The promiscuous ports are connected to layer 3 or layer 4 devices. Isolated ports and community ports are connected to individual user's servers, etc., and maintain traffic for each user separate from other users. The primary VLAN connects to all promiscuous ports, to all isolated ports, and to all community ports. The primary VLAN is a one way connection from promiscuous ports to isolated or community ports. An isolated VLAN connects to all promiscuous ports and to all isolated ports. The isolated VLAN is a one way connection from an isolated port to the promiscuous ports. A community VLAN is defined as connecting to a group of community ports, and also connecting to all of the promiscuous ports. The group of community ports is referred to as a "community" of community ports. A community VLAN is a one way connection from a community of ports to the promiscuous ports, but allows a packet received by one community port to be transmitted out of the switch, through the other community ports connected to that community VLAN.

46 Claims, 8 Drawing Sheets

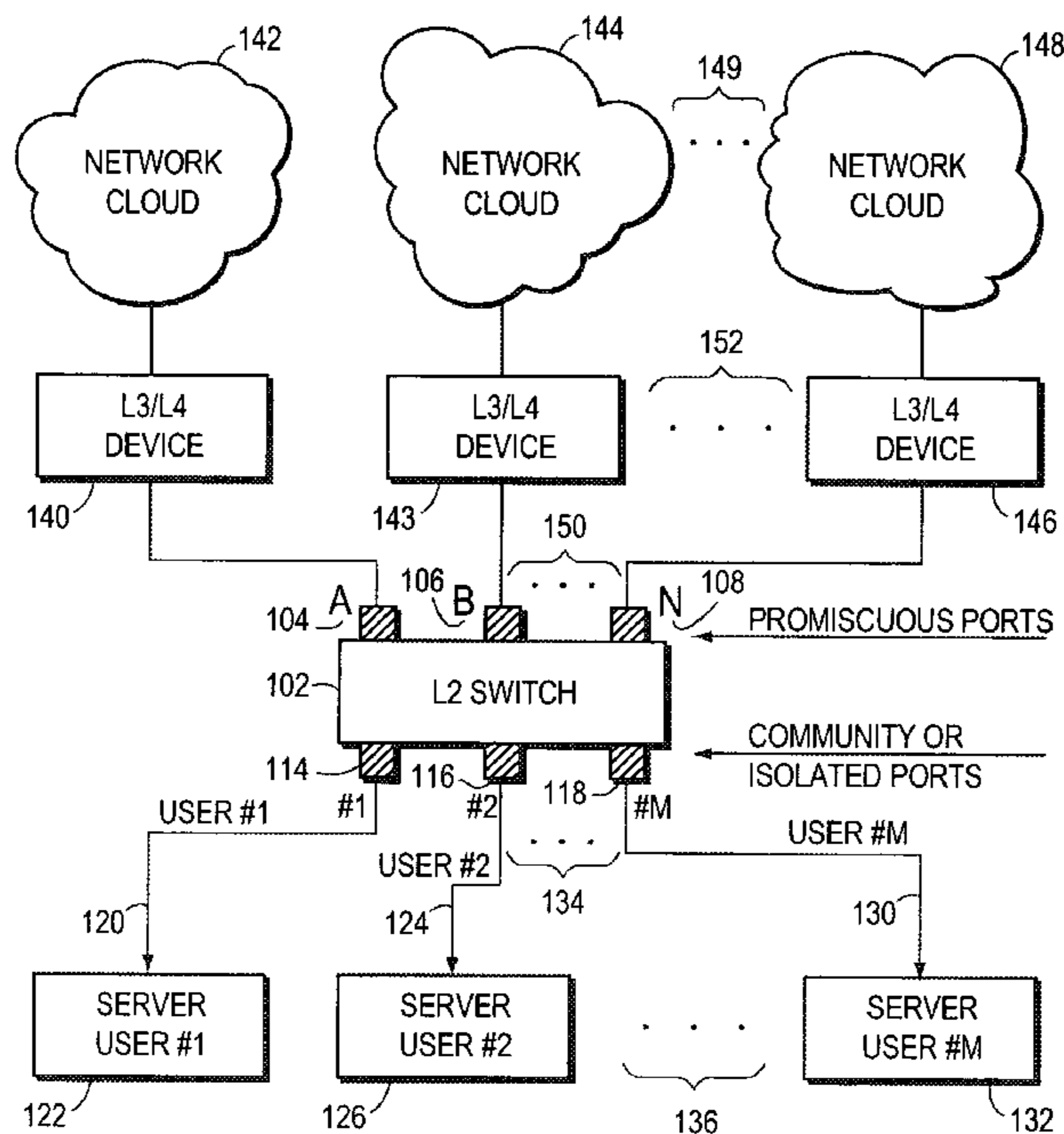

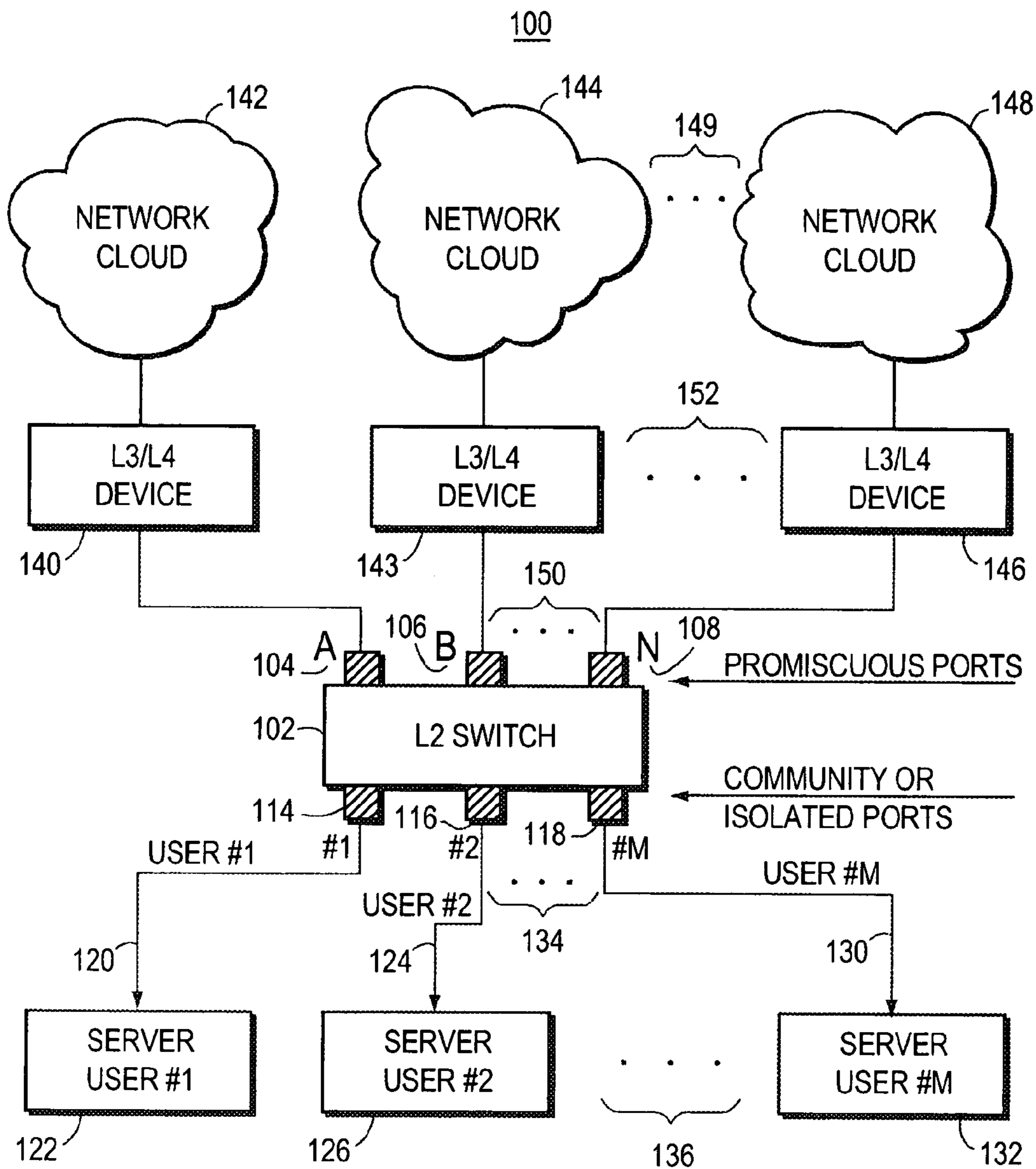

FIG. 1

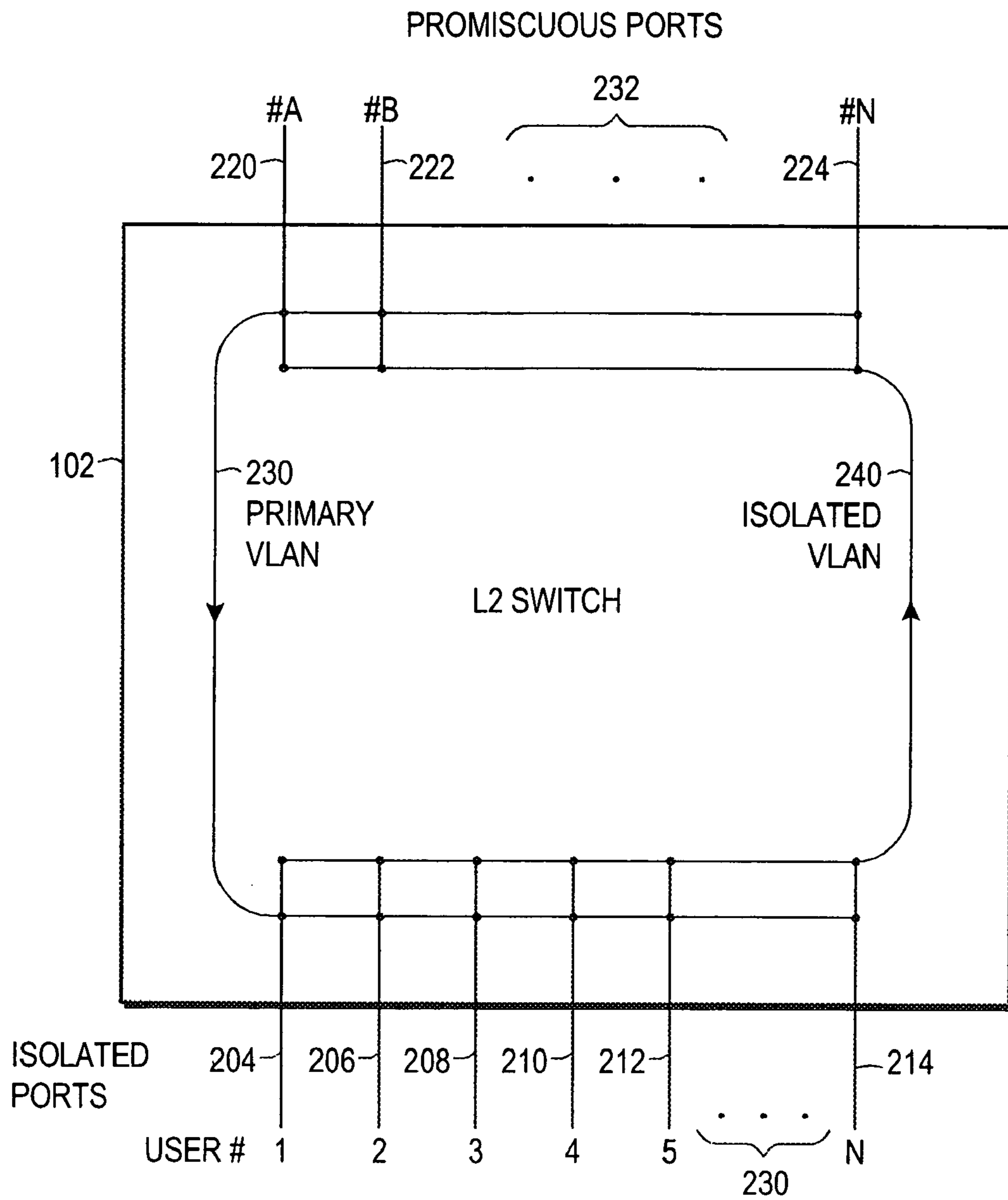

FIG. 2

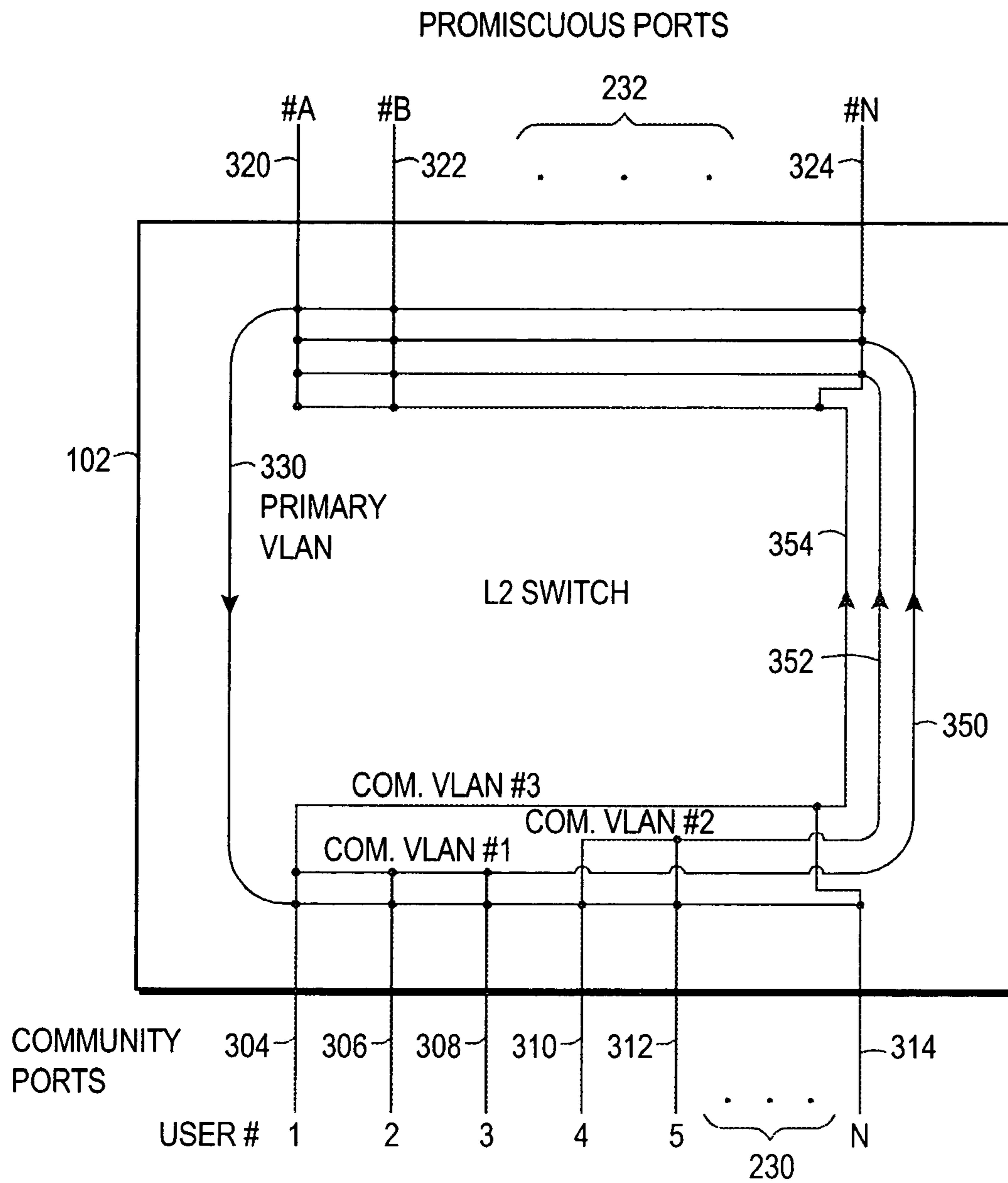

FIG. 3

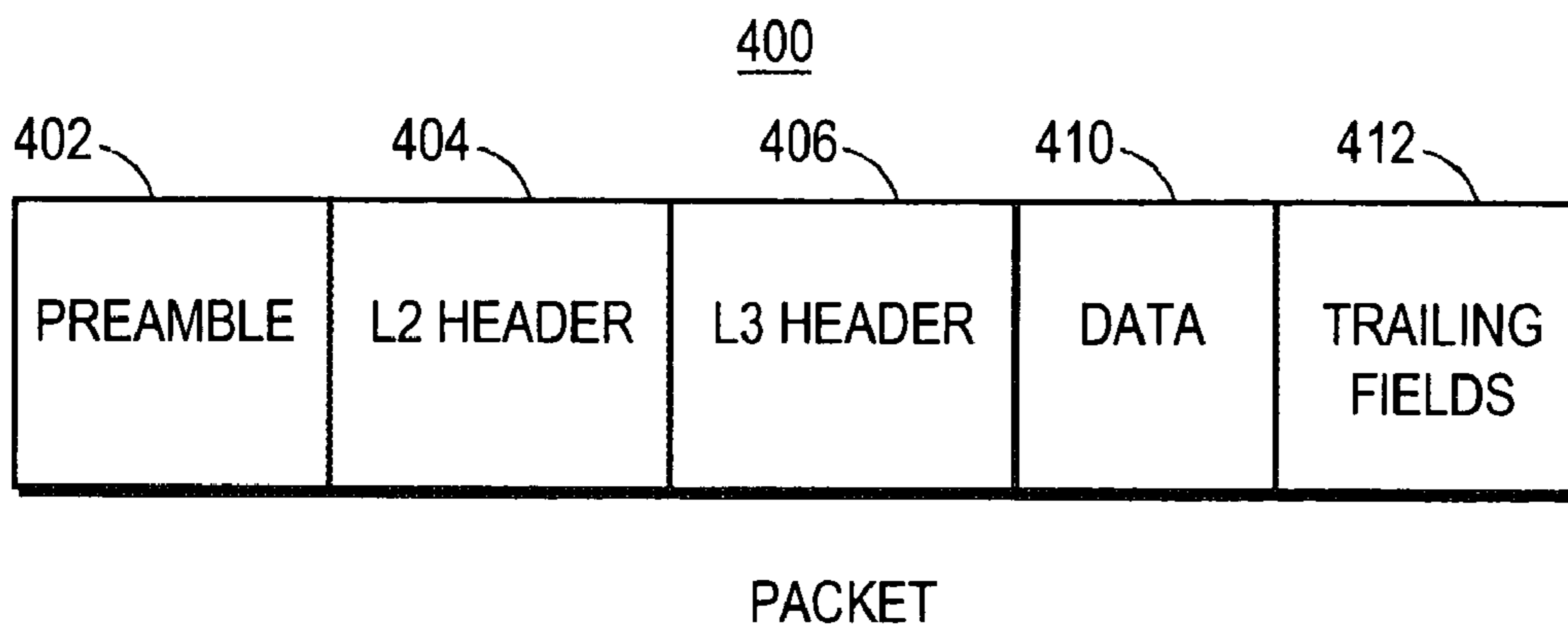

FIG. 4

500

502 L3 LAYER INTERFACE NUMBER	504 PRIMARY VLAN NUMBER	506 ISOLATED OR COMMUNITY VLAN NUMBER
512	514	
		⋮

PROMISCUOUS PORT
ASSIGNMENT TABLE
FOR OUTGOING TRAFFIC

FIG. 5

550

552 PRIMARY VLAN	554 SECONDARY VLANs	
2	20	560A
2	21	560B
2	22	560C
2	23	560D
3	30	570A
3	31	570B
3	32	570C
.	.	
.	.	
.	.	

TRUNK TYPE PROMISCUOUS
PORT VLAN MAPPING TABLE

FIG. 5A

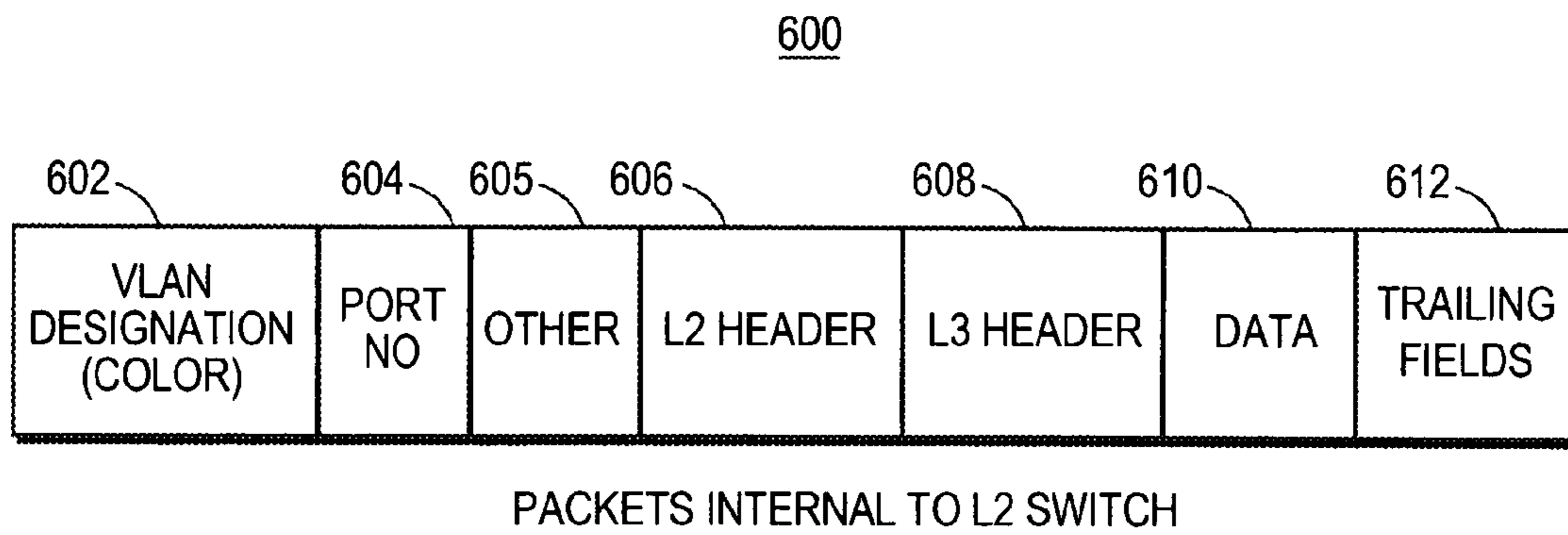

FIG. 6

700

702 PORT No.	706 ISOLATED OR COMMUNITY VLAN
712	716

710

ISOLATED OR COMMUNITY PORT
ASSIGNMENT TABLE

FIG. 7

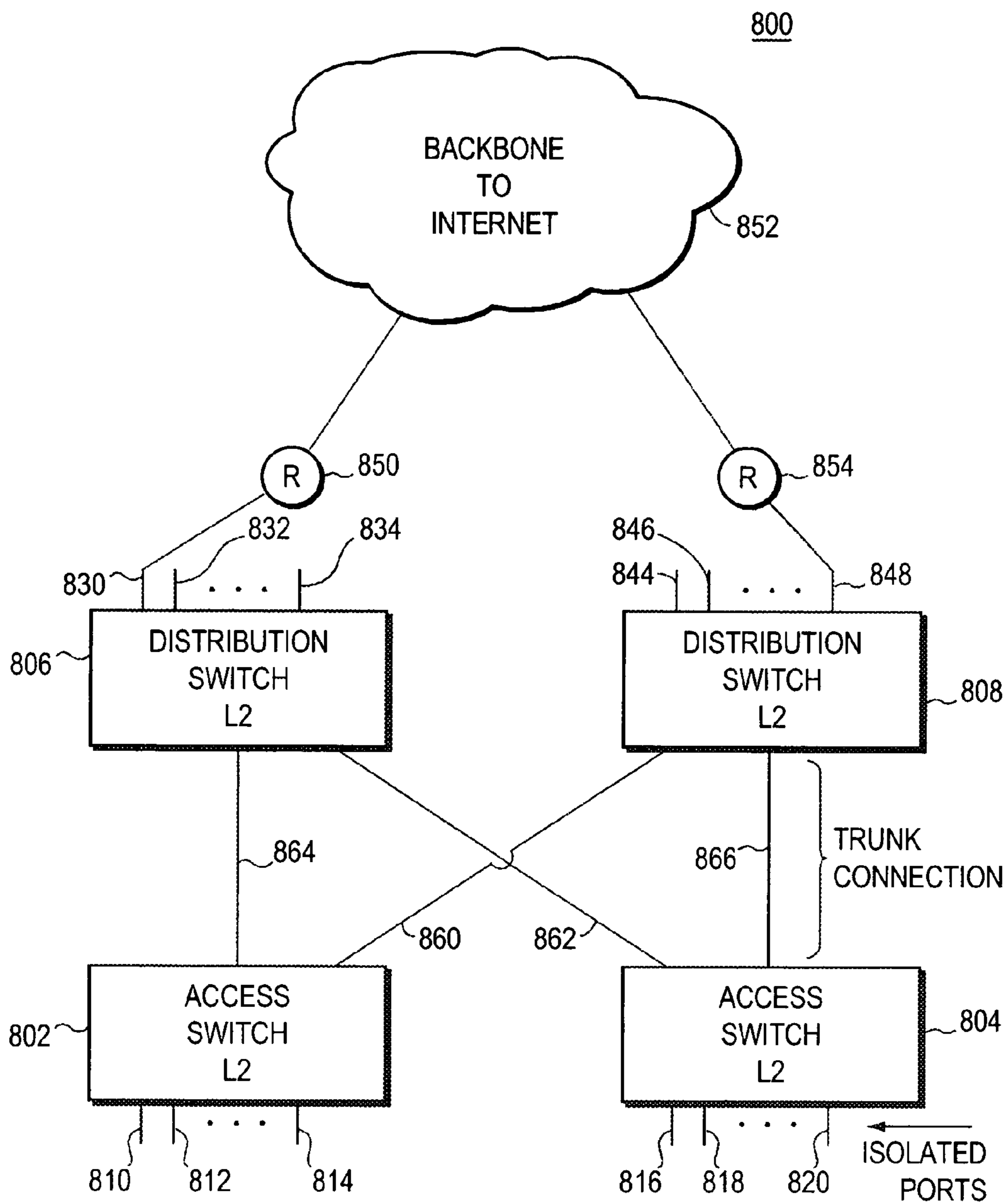

FIG. 8

1**PRIVATE VLANS**

BACKGROUND OF THE INVENTION

1. Field of the Invention

The invention relates to Virtual Local Area Networks (VLANs), and more particularly to the use of VLANs to establish separation between different users of a shared switch.

2. Background Information

It is today a common computer network engineering practice to separate packet traffic belonging to different users by use of a router, a Layer 3 (L3) device. Separation of users' traffic is accomplished by assigning each user to a different subnetwork (subnet). A subnet is identified by a unique L3 address. The router then transmits a particular user's packets out through a port assigned to that subnet. However, only a limited number of bits in the L3 address (for example IP address) are assigned to the subnet, and so only a limited number of subnets may be addressed by a particular router. Subnet design is described by Andrew Tanenbaum in his book Computer Networks, Third Edition, published by Prentice Hall, Copyright date 1996, all disclosures of which are incorporated herein by reference, particularly at pages 417-419. For example, if 6 bits are assigned to a subnet mask, then only 62 different subnets may be addressed (0 and 64 are reserved). Further, for every subnet assigned two addresses are wasted, for example the multicast and broadcast addresses.

As an example of many users of a switch who require that their message traffic be kept separate, an Internet service provider (ISP) may have many customers who want to connect to a server farm. Access to the ISP is through a router connected to a common external computer network, for example the worldwide Internet. The router must route each customer's traffic to that customer's local area network in such a manner as to maintain protection and privacy between the data of different customers. It is desirable for an ISP to prevent traffic originating from one customer's server from being received by another customer's server.

A second example of many users of a computer network who must have their traffic separated in order to guarantee privacy and protection is the use of a television cable Internet distribution system. Each home is assigned a separate subnet so that routers may route only a particular customer's message traffic to that customer. This subnet routing prevents, for example, one customer looking at another customer's message traffic by use of, for example, a network sniffer.

A third example is a server farm, for example a multicient backup service. Each client's message traffic arrives at a router. The router uses a subnet mask to keep the traffic of each client separate from the traffic of another client, as it routes the traffic to the client's backup server.

A limitation in the use of subnets, and subnet masks, in a multicient environment is that there is only a limited number of subnets which can be defined from standard Layer 3 addresses. In modern computer network systems, this numerical limitation severely restricts the number of individual users who can be serviced, and also have their message traffic maintained separate. Further, the management of a large number of subnets by a network manager becomes burdensome, especially in the event that the network has thousands of customers whose packet traffic must be kept separate.

2

A better way to keep the message traffic of different users separate in a computer network is needed, particularly a method which can scale to a large number of users.

SUMMARY OF THE INVENTION

The invention uses a layer 2 switch (L2 switch), or bridge, to separate user's message traffic by use of Virtual Local Area Networks (VLANs) defined within the switch. Three new types of ports are defined, "promiscuous" ports, "isolated" ports, and "community" ports. Three types of VLANs internal to the switch are defined, "primary" VLANs, "isolated" VLANs and "community" VLANs.

The promiscuous ports are connected to layer 3 or layer 4 devices, for example routers which may in turn connect to the worldwide Internet, load balancers which also may connect to the worldwide Internet, administrative work stations such as used by network administrators, back up devices, etc. Isolated ports and community ports are connected to individual user's servers, etc., and maintain traffic for each user separate from other users.

Isolated ports and community ports exchange packets with the promiscuous ports by use of the VLANs internal to the switch. The difference between isolated and community ports is that an isolated port cannot transfer packets to another isolated port, however a community port has a designated number of community ports to which it can transfer packets.

A primary VLAN internal to the switch is defined as follows. The primary VLAN connects to all promiscuous ports, to all isolated ports, and to all community ports. The primary VLAN receives packets from outside of the switch arriving at any of the promiscuous ports, and transfers the packets to the isolated or community ports. However, an isolated or community port cannot receive traffic from the external LAN connected to it, and transfer the packets to the primary VLAN. The primary VLAN is a one way connection from promiscuous ports to isolated or community ports.

An isolated VLAN is defined as connecting to all promiscuous ports and connecting to all isolated ports. An isolated VLAN receives packets arriving from outside of the switch at an isolated port, and transfers the packets to the promiscuous ports. An isolated VLAN does not carry packets received by a promiscuous port from outside of the switch. Also, an isolated VLAN does not deliver any packets to another isolated port. The isolated VLAN is a one way connection from an isolated port to the promiscuous ports.

A community VLAN is defined as connecting to a group of community ports, and also connecting to all of the promiscuous ports. The group of community ports is referred to as a "community" of community ports. The community VLAN transfers a packet received from outside the switch at a community port to all of the promiscuous ports, and also transfers the packet to the other community ports attached to that community VLAN. A plurality of "communities" of community ports may be defined, and each community of ports has its own assigned community VLAN. A community VLAN cannot transfer packets received from outside of the switch at a promiscuous port. A community VLAN is a one way connection from a community of ports to the promiscuous ports, but allows a packet received by one community port to be transmitted out of the switch, through the other community ports connected to that community VLAN.

These new types of VLANs and ports are implemented, in part, by particular settings of the Color Blocking Logic

(CBL) logic circuits used by normal ports of an L2 switch which supports VLANs, and also by use of assignment tables.

Traffic generated by different user's servers is kept separate from other user's servers, by each user having his own isolated port or community of community ports.

The VLANs defined in a first L2 switch chassis can be trunked to other L2 switch chassis using ordinary trunking technology, in order to increase the number of ports.

Alternatively, a single L2 switch, or a network of trunked L2 switches, may have its promiscuous ports divided into subsets. Each subset of promiscuous ports is then associated with its subset of isolated ports and community ports, along with the necessary VLANs.

Other and further aspects of the present invention will become apparent during the course of the following description and by reference to the accompanying drawings.

BRIEF DESCRIPTION OF THE DRAWINGS

Referring now to the drawings, in which like numerals represent like parts in the several views:

FIG. 1 is a block diagram of a computer network in accordance with the invention;

FIG. 2 is a block diagram of a L2 switch in accordance with the invention;

FIG. 3 is a block diagram of a L2 switch in accordance with the invention;

FIG. 4 is a field diagram of a layer 3 packet;

FIG. 5 is an assignment table for a promiscuous port for outgoing traffic, in accordance with the invention;

FIG. 5A is a Trunk Type Promiscuous Port VLAN Mapping Table, in accordance with the invention;

FIG. 6 is a field diagram of a VLAN packet internal to a L2 switch;

FIG. 7 is a port assignment table for an isolated or community port;

FIG. 8 is a block diagram of a two level layer 2-switch network in accordance with the invention.

DETAILED DESCRIPTION OF AN ILLUSTRATIVE EMBODIMENT

Turning now to FIG. 1, computer network 100 is shown.

L2 switch 102 has promiscuous ports, port A 104, port B 106, port N 108, etc. Promiscuous port 108 is indicated as "N", indicating that an arbitrary number of promiscuous ports may be employed by L2 switch 102.

L2 switch 102 also has isolated or community ports, port #1 114 is connected to user #1 VLAN 120, and user #1 VLAN 120 connects to user #1 server 122. Isolated or community port #2 116 connects to user #2 VLAN 124, and user #2 VLAN 124 connects to user #2 server 126. Isolated or community port #M 118 is labeled "M" to indicate that L2 switch 102 may have an arbitrary number of isolated or community ports. Isolated or community port #M 118 connects to user #M VLAN 130, and user #M VLAN 130 connects to user #M server 132. "Three dots" 134 indicate that L2 switch 102 may have a plurality of isolated or community ports, etc. "Three dots" 136 indicate that a plurality of user servers, each connected to a different isolated or community port, etc.

The promiscuous ports 104, 106, 108, etc. connect to layer 3 or layer 4 devices 140, 143, 146. Examples of layer 3 or layer 4 devices comprise routers, load balancers, administrative work stations, back-up devices, etc. An administrative work station is a work station utilized by a network

administrator and permits the administrator to view all, or at least many, of the occurrences on the network. Promiscuous Port A 104 connects to layer 3 or layer 4 device (L3/L4 device) A 140, and L3/L4 device 140 connects to network cloud 142. Promiscuous port B 106 connects to L3/L4 device 143, and L3/L4 device 143 connects to network cloud 144. Promiscuous port N 108 connects to L3/L4 device 146. L3/L4 device 146 connects to network cloud 148.

Three dots 150 indicate that L2 switch 102 may have a plurality of promiscuous ports, etc. Three dots 152 indicate a plurality of L3/L4 devices, connected to the promiscuous ports, port A 104, port B 106, port N 108, etc. Three dots 149 indicate that the L3/L4 devices may connect to a plurality of network clouds 142, 144, 148, etc.

Network clouds 142, 144, 148 may be different network clouds, for example each may comprise a backup device for a particular user server. Alternatively, each network cloud 142, 144, 148 may represent the worldwide Internet. Further, each network cloud 142, 144, 148, may represent a particular device, may represent several particular devices, and may also represent the worldwide Internet, etc.

Turning now to FIG. 2, the interior of L2 switch 102 is shown. Isolated port 204, 206, 208, 210, 212, 214 are labeled progressively as user #1, 2, 3, 4, 5, N, etc., and each may connect to a different user. Isolated ports 204, 206, 208, etc. correspond to isolated ports 114, 116, 118, etc. shown in FIG. 1. Promiscuous ports, port A 220, port B 222, port N 224, connect to various L3/L4 devices (not shown in FIG. 2), such as devices 140, 143, 146, etc. Promiscuous ports 220, 222, 224, etc. correspond to promiscuous ports 104, 106, and 108, etc. as shown in FIG. 1.

Three dots 230 indicate a plurality of users, each connected to an isolated port 204, 206, 208, 210, 212, 214, etc. Three dots 232 indicate a plurality of promiscuous ports, 220, 222, 224, etc. and indicate that L2 switch 102 may have a plurality of promiscuous ports.

The VLANs utilized by L2 switch 102 are described below.

VLAN 230 is a primary VLAN, and connects to promiscuous ports 220, 222, 224, etc., and also connects to each of the isolated ports 204, 206, 208, . . . 214, etc. Primary VLAN 230 carries packet traffic from the promiscuous ports to isolated ports. Primary VLAN 230 is configured to reject any packets arriving at an isolated port from the external local area network connected to the isolated port.

During ordinary operation, any packet received by a promiscuous port from the L3/L4 device is transmitted on the primary VLAN, and may be received by any isolated or community port having a destination for that packet on an external LAN connected thereto.

Isolated VLAN 240 connects to isolated ports 204, 206, 208, . . . 214, etc., and also connects to each of the promiscuous ports 224, 222, . . . 220, etc. Isolated VLAN 240 carries packet traffic from isolated ports to the promiscuous ports. Isolated VLAN 240 is configured to reject any traffic arriving from a promiscuous port. Also, isolated VLAN 240 is configured so that it cannot deliver any packets to an isolated port. That is, packets transferred onto isolated VLAN 240 by an isolated port cannot be received by another isolated port. Packets transferred onto isolated VLAN 240 from an isolated port are received by promiscuous ports 220, 222, 224, etc., and from the promiscuous ports may be transferred to network clouds, for example, network cloud 142, 144, 148.

Mechanisms, for example, color blocking logic (CBL) and assignment tables, may be used to permit primary VLAN 230 to transfer packets from promiscuous ports to

5

isolated ports, and prohibit an isolated port from transmitting onto primary VLAN **230**. Also, mechanisms within L2 switch **102** such as CBL and assignment tables may be used to permit isolated VLAN **240** to transfer packet traffic from an isolated port to a promiscuous port, and prevent isolated VLAN **240** from transferring a packet to an isolated port.

Community VLANs implemented in L2 switch **102** are described next.

A community VLAN connects to a designated group of community ports, and to all of the promiscuous ports. A community port receives a packet from outside of switch **102** and transfers the packet to the community VLAN. A packet transferred to the community VLAN from a community port is received by all of the community ports connected to the community VLAN, and also all of the promiscuous ports receive the packet from the community VLAN. The promiscuous ports then transfer the packet out of the L2 switch. A Community VLAN is configured to reject any traffic arriving from a promiscuous port.

Turning now to FIG. **3**, community VLAN #**1 350**, community VLAN #**2 352**, and, community VLAN #**3 354** are shown. Community VLAN #**1 350** is shown connected to community ports **306**, and **308**. Community VLAN #**1 350** permits community ports connected thereto to exchange packets. For example, a packet entering L2 switch **102** from user #**2** at community port **306** is transferred by community VLAN #**1 350** to the other community ports, for example community ports **308**, etc., connected to community VLAN #**1 350**, and is also transferred to all of the promiscuous ports, ports **320**, **322**, **324**

Community VLAN #**2 352** is shown connected to community port **310** and **312**. A packet originating from user #**4** or user #**5** will enter L2 switch **102** at either community port **310**, **312**, respectively, and will be transferred by community VLAN #**2 352** to the other isolated port, and to all of the promiscuous ports **320**, **322**, . . . **324**, etc.

As a further example of a community VLAN, community VLAN #**3 354** is shown. Community VLAN #**3 354** is shown connected to community port **304** and community port **314**. Community VLAN #**3 354** also connects to all of the promiscuous ports **320**, **322**, . . . **324**, etc.

In the present description, the isolated ports are shown in FIG. **2**, and the community ports are shown in FIG. **3**. Switch **102** may have, for example, both isolated ports and community ports. In this case, both of the port arrangements of FIG. **2** and of FIG. **3** are implemented within L2 switch **102**. In a second exemplary embodiment, L2 switch **102** may have only isolated ports as shown in FIG. **2**. In a third exemplary embodiment, L2 switch **102** may have only community ports as shown in FIG. **3**.

A terminology which can be used is to refer to the isolated VLAN and the community VLAN as a "secondary" VLAN. Using this terminology, a primary VLAN takes packets from the promiscuous ports to either the isolated ports or the community ports. In contrast, the secondary VLAN takes packets from either the isolated ports or community ports to the promiscuous ports.

Turning now to FIG. **4**, a field diagram **400** of a typical L2 packet which reaches an L2 switch from a network cloud is shown. Field **402** is the preamble. Field **404** contains the L2 header. Field **406** contains the L3 header. Data carried by packet **400** is in field **410**. Trailing fields **412** contain fields typically trailing the data fields of a typical data packet, and normally include a cyclical redundancy check (CRC) field.

The field diagram of a packet shown in FIG. **4** also represents the fields in a packet departing from L3/L4 device

6

104, etc. to network cloud **142**, or any of the other network clouds from one of the other L3/L4 devices.

Turning now to FIG. **5**, "Promiscuous Port Assignment Table for Outgoing Traffic" **500** is shown with three columns. Table **500** is a conceptual table which is an aid to understanding the invention. Data shown in table **500** may be held, in a particular implementation, in a variety of places. For example some data is in the header of a received packet, some data may be held in hardware such as memory in an ASIC chip in the interface, or further, some of the data may be held in a software lookup table in the memory for a processor of the router. As a further example, an implementation may use a table such as Table **500** in main memory for a processor of the router. Column **502** contains a layer 3 interface number. Column **504** contains a primary VLAN assignment number. Column **506** contains an isolated or community VLAN assignment number.

A primary VLAN Assignment Number, as held in column **504**, is a designation which is written into a field of a packet transferred from layer 2 switch **102** to L3/L4 device **140**, or, for example, any of the other L3/L4 devices **143**, **146**, etc., using standard L2 switch to L3/L4 device protocol. For example, the Primary VLAN Number may be written into the L3 data field **410** as part of a Layer 4 (L4) header using a standard VLAN protocol. The receiving network device reads the primary VLAN number from the header, writes it into column **504**, and makes a one-to-one correspondence with a layer 3 interface number (L3 Interface Number) which is written into column **502**. Table **500** then may have multiple entries in column **506** for a many to one correspondence. That is, there may be many entries in column **506**, one for the isolated VLAN, and one entry for each community VLAN associated with that primary VLAN.

Rows, for example, row **510** of promiscuous port assignment table **500** for to outgoing traffic, contain an entry for each Layer 3 Interface Number. A Layer 3 Interface Number corresponds to a L3 destination address to which a Layer 3/Layer 4 (L3/L4) device **140**, etc., transfers data packets in computer network **100**.

In operation, a packet arrives at a promiscuous port on an isolated VLAN or a community VLAN for transmission out of L2 switch **102**. A process enters Promiscuous Port Assignment Table for Outgoing Traffic **500** through either the isolated VLAN number or the community VLAN number, thereby obtaining the corresponding L3 Interface Number from column **502** of the entry. The Primary VLAN directs the packet from the L2 switch **102** to the proper L3/L4 device **140**, etc., using a protocol for transfer of packets from a L2 switch to a L3/L4 device. The L3/L4 device then interprets the Primary VLAN and directs the packet to the appropriate destination address in Network Cloud **142**, etc.

Alternatively, the Primary VLAN of the destination computer could be held in Column **504** of Promiscuous Port Assignment Table for Outgoing Traffic **500**, and the packet transferred, for example by TCP/IP, from L2 switch **102** to the L3/L4 device.

In the conceptual table "Promiscuous Port Assignment Table for Outgoing Traffic", Table **500** there is a one-to-one correspondence between a Primary VLAN number and a L3 Interface number. An L3 Interface, designated by L3 Interface Number, is usually associated to a subnet, that is to a whole group of addresses. Once the packets reach an L3 Interface, then are normally routed by the router without any remaining knowledge of the Private VLANs. At the L3 Interface there is no distinction between normal traffic, and traffic coming from a private VLAN.

During operation, a packet such as network packet **400** shown in FIG. 4, is received by an L3/L4 device, for example, L3/L4 device **140**, etc. from a network cloud, for example, network cloud **142**. The received packet has the field structure as shown in fields **400** of FIG. 4. The network packet is transferred by the receiving L3/L4 device to L2 switch **102**. L2 switch **102** receives the packet on a promiscuous port, for example, port **104**, **106**, . . . , **108**. Upon receipt by a promiscuous port, the packet is transferred to primary VLAN **230**, **330** as shown in FIG. 2 or FIG. 3 respectively. The packet then is transferred to each of the isolated ports **204**, **206**, **208** . . . **214**, etc and community ports **304**, . . . **314**, etc. The packet is transmitted out of the appropriate isolated port or community port by the L2 switch **102** using standard forwarding mechanisms, for example by TCP/IP.

A typical entry for a Primary VLAN is shown at entry **510**. Entry **510** shows the one-to-one correspondence between the L3 Interface Number held in field **512** and the Primary VLAN Number held in field **514**. Associated with entry **510** are a plurality of entries for isolated or community VLANs, as shown in fields **516**, **518**, **520**, and a possible extension to further “many” entries shown by “three dots” **522**.

As an example, primary VLANs and secondary VLANs (that is Isolated or Community VLANs) are programmed in the router using Color Blocking Logic (CBL). A special value is programmed for all primary and secondary VLANs. For example, a value of “forwarding” as defined in the Spanning Tree Protocol Standard IEEE 802. ID may be used. This exemplary assignment allows the hardware to let all the traffic from those VLANs out of the port, and also to accept the ingress traffic for the primary VLANs.

In the event that the port needs to be able to map many-secondaries-to-one-primary only, this exemplary mapping method is sufficient to define the promiscuous port. A port having mapping of many-secondaries-to-one-primary only port is referred to as a “non-trunk” promiscuous port.

Alternatively, in the event that the port needs to be able to map many-secondaries-to-different-primaries, then an explicit table such as “Trunk Type Promiscuous Port VLAN Mapping Table” **550** as given in FIG. 5A may be employed to provide the required mapping. A port which maps many-secondaries-to-different-primaries is referred to as a “trunk” type promiscuous port. Turning now to FIG. 5A, column **552** holds an indicia of the Primary VLAN. Column **554** contains an indicia of the Secondary VLANs (either Isolated or Community VLANs) corresponding to the Primary VLAN.

For example, entries **560** refer to Primary VLAN number “2”. Entries **570** refer to Primary VLAN number “3”, etc.

Primary VLAN “2” is shown associated with: Secondary VLAN “20” at entry **560A**; Secondary VLAN “21” at entry **560B**; Secondary VLAN “22” at entry **560C**; Secondary VLAN “23” at entry **560D**, etc.

Further, Primary VLAN “3” is shown associated with: Secondary VLAN “30” at entry **570A**; Secondary VLAN “31” at entry **570B**; with Secondary VLAN “32” at entry **570C**, etc. Entries **580**, represented by “three dots” in both column **552** and **554**, indicate that a further plurality of Primary VLANs may each be associated with its particular plurality of secondary VLANs by use of “Trunk Type Promiscuous Port VLAN Mapping Table” **550**.

Turning now to FIG. 6, packet **600** is shown. Packet **600** is the VLAN packet travelling inside L2 switch **102**. Fields of packet **600** are shown. Field **602** contains the VLAN designation to which the packet is transferred. VLAN designations are sometimes referred to as a “color”, as is

indicated in field **602**. Field **604** contains the port number of the port designated to receive that particular packet. Field **605** contains any other fields carried by the packet as it travels through the internals of L2 switch **102**.

When packet **600** represents a packet received at a promiscuous port, then field **604** contains the port number of the isolated port **204**, **206**, **208**, . . . **214**, etc., or community port **304**, **306**, . . . **314**, etc., to which the packet is directed. The port circuitry reads field **604** and the correct port then receives the packet.

When packet **600** represents a packet received from an isolated or community port, the isolated or community VLAN number is written into field **602**, and the port number of the promiscuous port designated to receive the packet is written into field **604**.

When the receiving port is a community port, a distinction is made between unicast packets and broadcast packets. When the packet is a unicast packet, and in the rare event that the hardware has not yet learned the packet destination address, the packet is broadcast on the community ports so that the hardware can learn the address-port-association. Subsequent unicast packets to this particular community address are then forwarded out through the appropriate port.

In the alternative event that the incoming packet is a broadcast packet, the packet is replicated and forwarded out through each of the community ports of the community of designated ports.

Field **608** contains the L3 header of the underlying packet. Field **610** contains the data which is/was transmitted through the Internet. Field **612** contains the trailing fields of the underlying packet.

Turning now to FIG. 7, isolated or community port assignment table **700** is shown.

Isolated or community port assignment table **700** contains entries for directing a packet received from outside of switch **102** by an isolated or community port. Column **702** contains the isolated or community port number from which a packet is received, for example from a user LAN. Column **706** contains the designation of the isolated or community VLAN associated with that isolated or community port.

A typical entry **710** of isolated or community port assignment table **700** is shown. The isolated or community port number is found in field **712**. The designation of the isolated or community VLAN associated with that isolated or community port is found in field **716**.

During typical operation, a packet is received at an isolated or community port, port **114**, **116**, . . . **118**, etc. from an external LAN connected to the port. A process in L2 switch **102** uses the port number at which the packet was received as an entry into table **700** at column **702**, and finds the receiving port number in field **712**. The process then reads the isolated or community VLAN to which the packet is to be transferred from field **716**.

Turning now to FIG. 8, computer network **800** is shown in an alternative embodiment of the invention. Access switch **802** and access switch **804** are typically L2 switches. Distribution switch **806** and distribution switch **808** are also both typically L2 switches. The access switches and the distribution switches are trunked together so as to share VLANs.

Computer network **800** has two layers of Layer 2 switching, the lower layer comprises access switch **802**, and access switch **804**. The higher, or second, level of Layer 2 switching in network **800** comprises distribution switch **806** and distribution switch **808**. Typical Layer 2 switch trunk connections **860**, **862**, **864**, and **866** are shown. Trunk connection **860** connects access switch **802** with distribution switch

808; trunk **862** connects access switch **804** with distribution switch **806**; trunk connection **864** connects access switch **802** with distribution switch **806**; and, trunk connection **866** connects access switch **804** with distribution switch **808**. The trunk connections, **860**, **862**, **864**, **866** are typical standard engineering practice trunk connections between Layer 2 switches. The trunk connections carry all of the VLANs interconnecting the access switches **802**, **804** with the distribution switches **806**, **808**.

The two layers of Layer 2 switching, represented by the lower layer of access switches **802**, **804** and the upper layer represented by distribution switches **806**, **808**, are a generalization of L2 switch **102**. The two layer switching arrangement in network **800** at Layer 2 permits the implementation of more ports in the network so that a greater number of server users, for example, **122**, **126**, **132**, etc. may be serviced by the system.

Access switch **802** has isolated or community ports **810**, **812**, . . . **814**, etc., and these isolated or community ports are analogous to isolated or community ports **114**, **116**, . . . **118**, etc. of L2 switch **102**. Access switch **804** also has similar isolated or community ports **816**, **818**, . . . **820**, etc. The isolated or community ports are connected to external LANs which in turn connect to customer's servers, customer's other equipment, etc., as shown in FIG. 1.

Distribution switch **806** and distribution switch **808** have promiscuous ports connected to Layer 3 routers. Distribution switch **806** has promiscuous port **830**, promiscuous port **832**, . . . promiscuous port **834**, etc. Distribution switch **808** has promiscuous port **844**, **846**, . . . **848**, etc.

Trunk connections **860**, **862**, **864**, **866**, etc. carry the primary VLANs, the isolated VLANs, and the community VLANs interconnecting the promiscuous ports, the isolated ports, and the community ports.

Network **800** is analogous to L2 switch **102**, in that the access switches **802**, **804** provide the isolated or community ports, the distribution switches **806**, **808** provide the promiscuous ports, and the trunk lines **860**, **862**, **864**, **866** carry the necessary VLANs. Also, a further plurality of L2 switches may be trunked together as access switches to provide a desired number of ports for customer's equipment. Also, a further plurality of L2 switches may be trunked together as distribution switches to provide more connections to routers connecting to the Internet.

As an example, promiscuous port **830** of distribution switch **806** is shown connected to router **850**. In turn, router **850** connects to network cloud **852**, which is labeled "backbone to Internet". Network cloud **852** is typically a connection to the Internet, and alternatively represent the world wide Internet itself. Also, distribution switch **808** has port **848** shown connected, for example, to router **854**. Router **854** also connects to network cloud **852**. In operation, router **850** and router **854** connect the distribution layer switches **806**, **808** to the Internet.

In the exemplary embodiment of the invention described above, the primary VLAN **230**, **330** connects to all of the promiscuous ports, however in an alternative exemplary embodiments of the invention, a single primary VLAN may connect to only a subset of promiscuous ports. In such an alternative embodiment of the invention, there may be a plurality of primary VLANs, each with its associated promiscuous ports and associated isolated or community ports. Implementing a plurality of primary VLANs gives a system designer flexibility in arranging connections to L3/L4 devices through promiscuous ports, and to user equipment connected at isolated ports or community ports.

It is to be understood that the above described embodiments are simply illustrative of the principles of the invention. Various other modifications and changes may be made by those skilled in the art which embody the principles of the invention and fall within the spirit and scope thereof.

What is claimed is:

1. A method for operating a router, comprising:
 - establishing a first VLAN from a port connected to a shared network to a plurality of user ports, the first VLAN receiving packets from the shared network and transferring them to a designated user port, the first VLAN rejecting packets from the user ports;
 - establishing a second VLAN from the plurality of user ports, the second VLAN receiving packets from the user ports and transferring them to the port connected to the shared network, the second VLAN preventing transfer of packets from one of the user ports to other user ports, and the second VLAN also rejecting packets from the shared network, in order to separate packet traffic of different users.
2. The method as in claim 1, further comprising:
 - dividing the plurality of user ports into groups of user ports, each group of user ports assigned to a single designated user; and
 - establishing a third VLAN from a first group of user ports, the third VLAN receiving packets from the first group of user ports and transferring them to the port connected to the shared network, the third VLAN able to transfer packets among user ports belonging to the first group of user ports, the third VLAN preventing transfer of packets to other user ports belonging to a group different from the first group of user ports, the third VLAN rejecting packets from the shared network.
3. A router, comprising:
 - means for establishing a first VLAN from a port connected to a shared network to a plurality of user ports, the first VLAN receiving packets from the shared network and transferring them to a designated user port, the first VLAN rejecting packets from the user ports;
 - means for establishing a second VLAN from the plurality of user ports, the second VLAN receiving packets from the user ports and transferring them to the port connected to the shared network, the second VLAN preventing transfer packets from one of the user ports to other user ports, and the second VLAN also rejecting packets from the shared network, in order to separate packet traffic of different users.
4. The router as in claim 3, further comprising:
 - means for dividing the plurality of user ports into groups of user ports, each group of user ports assigned to a single designated user; and
 - means for establishing a third VLAN from a first group of user ports, the third VLAN receiving packets from the first group of user ports and transferring them to the port connected to the shared network, the third VLAN able to transfer packets among user ports belonging to the first group of user ports, the third VLAN preventing transfer of packets to other user ports belonging to a group different from the first group of user ports, the third VLAN rejecting packets from the shared network.
5. A router, comprising:
 - a port connected to a shared network;
 - a plurality of user ports;
 - a first VLAN from the port connected to the shared network to the plurality of user ports, the first VLAN to receive packets from the shared network and transfer-

11

ring them to a designated user port, the first VLAN to reject packets from the user ports;

a second VLAN from the plurality of user ports, the second VLAN to receive packets from the user ports and transferring them to the port connected to the shared network, the second VLAN to prevent transfer of packets from one of the user ports to other user ports, and the second VLAN also to reject packets from the shared network, in order to separate packet traffic of different users.

6. The router as in claim 5, further comprising:

a third VLAN from a first group user ports of a plurality of groups of user ports, each group of user ports assigned to a single designated user, the third VLAN to receive packets from the user ports and transfer them to the port connected to the shared network, the third VLAN able to transfer packets among user ports belonging to the first group of user ports, the third VLAN to prevent transfer of packets to other user ports belonging to a group different from the first group of user ports, the third VLAN to reject packets from the shared network.

7. A router, comprising:

one or more promiscuous ports;

one or more isolated ports;

one or more community ports;

a primary VLAN, the primary VLAN to receive packets from outside of the router through the one or more promiscuous ports and to transfer the packets to a selected one of the one or more isolated ports and to transfer the packets to the one or more community ports, the primary VLAN to reject packets from the one or more isolated ports and to reject packets from the one or more community ports;

an isolated VLAN, the isolated VLAN to receive packets from outside of the router through an isolated port of the one or more isolated ports and to transfer the packets to the one or more promiscuous ports, the isolated VLAN to prevent transfer of the packets from the isolated port to another isolated port of the one or more isolated ports, and the isolated VLAN to prevent transfer of the packets from the isolated port to the one or more community ports, and the isolated VLAN to reject packets from the one or more promiscuous ports; and

a community VLAN, the community VLAN to receive packets from outside of the router at a community port of the one or more community ports and to transfer the packets to the one or more promiscuous ports and to transfer the packets to any other community ports, the community VLAN to prevent transfer of packets to the one or more isolated ports, the community VLAN to reject packets from the one or more promiscuous ports.

8. The router as in claim 7, further comprising:

a promiscuous port of the one or more promiscuous ports connected to a shared network, the shared network carrying packet traffic of a first user and packet traffic of a second user; and

a first isolated port of the one or more isolated ports connected to a local area network (LAN) assigned to the first user, and a second isolated port of the one or more isolated ports connected to a LAN assigned to the second user, in order to separate The packet traffic of the first user and the second user.

12

9. The router as in claim 7, further comprising:

a plurality of sets of community ports; and

a community VLAN for each set of community ports, the community VLAN for a particular set of community ports to prevent transfer packets to another set of community ports.

10. The router as in claim 7, further comprising:

a promiscuous port of the one or more promiscuous ports connected to a shared network, the shared network carrying packet traffic of a first user and packet traffic of a second user; and

a first set of community ports of the one or more community ports connected to a local area network (LAN) assigned to the first user, and a second set of community ports of the one or more community ports connected to a LAN assigned to the second user, in order to separate the packet traffic of the first user and the second user.

11. A router, comprising:

one or more promiscuous ports;

one or more isolated ports;

a primary VLAN, the primary VLAN to receive packets from outside of the router through the one or more promiscuous ports and to transfer the packets to a selected one of the one or more isolated ports, the primary VLAN to reject packets from the one or more isolated ports; and

an isolated VLAN, the isolated VLAN to receive packets from outside of the router through an isolated port of the one or more isolated ports and to transfer the packets to the one or more promiscuous ports, the isolated VLAN to prevent transfer of the packets from the isolated port to another isolated port of the one or more isolated ports, and the isolated VLAN to reject packets from the one or more promiscuous ports.

12. A router, comprising:

one or more promiscuous ports;

one or more community ports;

a primary VLAN, the primary VLAN to receive packets from outside of the router through the one or more promiscuous ports and to transfer the packets to a selected one of the one or more isolated ports, the primary VLAN to reject packets from the one or more isolated ports; and

a community VLAN, the community VLAN to receive packets from outside the router at a community port of the one or more community ports and to transfer the packets to the one or more promiscuous ports and to transfer the packets to any other community ports of the one or more community ports, the community VLAN to reject packets from the one or more promiscuous ports.

13. A router, comprising:

one or more promiscuous ports;

one or more other ports;

a primary VLAN, the primary VLAN to receive packets from outside of the router through the one or more promiscuous ports and to transfer the packets to a selected one of the one or more other ports, the primary VLAN to reject packets from the one or more other ports; and

a second VLAN, the second VLAN to receive packets from outside the router at the one or more other ports and to transfer the packets to the one or more promiscuous ports, the second VLAN to reject packets from the one or more promiscuous ports.

13

14. The router as in claim 13, further comprising:
said second VLAN to transfer the packets to the one or
more other ports.
15. A router, comprising:
one or more promiscuous ports; 5
one or more other ports;
a primary VLAN, the primary VLAN to receive packets
from outside of the router through the one or more
promiscuous ports and to transfer the packets to the one
or more other ports, the primary VLAN to reject 10
packets from the one or more other ports; and
a second VLAN, the second VLAN to receive packets
from outside the router at a one or more other ports and
to transfer the packets to a promiscuous port of the one
or more promiscuous ports, the second VLAN to reject 15
packets from the one or more promiscuous ports.
16. The router as in claim 15, further comprising:
the one or more other ports are one or more an isolated
ports. 20
17. The router as in claim 15, further comprising:
the one or more other ports are one or more community
ports.
18. A method for using a router, comprising:
establishing one or more promiscuous ports; 25
establishing one or more isolated ports;
establishing one or more community ports;
receiving a-packets by a primary VLAN, the primary
VLAN receiving the packets from outside of the router
through the one or more promiscuous ports and trans- 30
ferring the packets to a selected one of the one or more
isolated ports and transferring the packets to the one or
more community ports, the primary VLAN rejecting
packets from the one or more isolated ports and reject- 35
ing packets from the one or more community ports;
receiving packets by an isolated VLAN, the isolated
VLAN receiving the packets from outside of the router
through an isolated port of the one or more isolated
ports and transferring the packets to the one or more 40
promiscuous ports, the isolated VLAN preventing
transfer of the packets from the isolated port to another
isolated port of the one or more isolated ports, and the
isolated VLAN preventing transfer of the packets from
the isolated port to the one or more community ports, 45
and the isolated VLAN rejecting packets from the one
or more promiscuous ports; and
receiving packets by a community VLAN, the community
VLAN receiving packets from outside of the router at
a community port of the one or more community ports 50
and transferring the packets to the one or more pro-
miscuous ports and transferring the packets to any other
community ports, the community VLAN preventing
transfer of packets to the one or more isolated ports,
and the community VLAN rejecting packets from the 55
one or more promiscuous ports.
19. The method of claim 18, further comprising:
connecting a promiscuous port of the one or more pro-
miscuous ports to a shared network, the shared network
carrying packet traffic of a first user and packet traffic 60
of a second user; and
connecting a first isolated port of the one or more isolated
ports to a local area network (LAN) assigned to the first
user, and connecting a second isolated port of the one
or more isolated ports to a LAN assigned to the second 65
user, in order to separate the packet traffic of the first
user and the second user.

14

20. The method of claim 18, further comprising:
establishing a plurality of sets of community ports; and
connecting a community VLAN for each set of commu-
nity ports, the community VLAN for a particular set of
community ports preventing transfer of packets to
another set of community ports.
21. The method of claim 18, further comprising:
connecting a promiscuous port of the one or more pro-
miscuous ports to a shared network, the shared network
carrying packet traffic of a first user and packet traffic
of a second user; and
connecting a first set of community ports of the one or
more community ports to a local area network (LAN)
assigned to the first user, and connecting a second set
of community ports of the one or more community
ports connected to a LAN assigned to the second user,
in order to separate the packet traffic of the first user
and the second user.
22. A method for using a router, comprising:
establishing one or more promiscuous ports;
establishing one or more isolated ports;
receiving packets by a primary VLAN, the primary
VLAN receiving packets from outside of the router
through the one or more promiscuous ports and trans-
ferring the packets to a selected one of the one or more
isolated ports, the primary VLAN rejecting receive
packets from the one or more isolated ports; and
receiving packets by an isolated VLAN, the isolated
VLAN receiving packets from outside of the router
through an isolated port of the one or more isolated
ports and transferring the packets to the one or more
promiscuous ports, the isolated VLAN preventing
transfer of the packets from the isolated port to another
isolated port of the one or more isolated ports, and the
isolated VLAN rejecting packets from the one or more
promiscuous ports.
23. A method for using a router, comprising:
establishing one or more promiscuous ports;
establishing one or more community ports;
receiving packets by a primary VLAN, the primary
VLAN receiving packets from outside of the router
through the one or more promiscuous ports and trans-
ferring the packets to the one or more community ports,
the primary VLAN rejecting packets from the one or
more community ports; and
receiving packets by a community VLAN, the community
VLAN receiving packets from outside the router at a
community port of the one or more community ports
and transferring the packets to the one or more pro-
miscuous ports and transferring the packets to any other
community ports of the one or more community ports,
the community VLAN rejecting packets from the one
or more promiscuous ports.
24. A method for using a router, comprising:
establishing one or more promiscuous ports;
establishing one or more other ports;
receiving packets by a primary VLAN, the primary
VLAN receiving packets from outside of the router
through the one or more promiscuous ports and trans-
ferring the packets to a selected one of the one or more
other ports, the primary VLAN rejecting packets from
the one or more other ports; and
receiving packets by a second VLAN, the second VLAN
receiving packets from outside the router at the one or
more other ports and transferring the packets to the one
or more promiscuous ports, the second VLAN rejecting
packets from the one or more promiscuous ports.

15

25. The method as in claim 24, further comprising:
transferring the packets by the second VLAN to the one
or more other ports.
26. A method for using a router, comprising:
establishing one or more promiscuous ports; 5
establishing one or more other ports;
receiving packets by a primary VLAN, the primary
VLAN receiving packets from outside of the router
through the one or more promiscuous ports and trans-
ferring the packets to the one or more other ports, the 10
primary VLAN rejecting packets from the one or more
other ports; and
receiving packets by a second VLAN, the second VLAN
receiving packets from outside the router at a one or
more other ports and transferring the packets to a 15
promiscuous port of the one or more promiscuous
ports, the second VLAN rejecting packets from the one
or more promiscuous ports.
27. The method as in claim 26, further comprising:
establishing the one or more other ports as one or more 20
isolated ports.
28. The method as in claim 26, further comprising:
establishing the one or more other ports as one or more
community ports.
29. A router, comprising: 25
means for establishing one or more promiscuous ports;
means for establishing one or more isolated ports;
means for establishing one or more community ports;
means for receiving packets by a primary VLAN, the 30
primary VLAN receiving the packets from outside of
the router through the one or more promiscuous ports
and transferring the packets to a selected one of the one
or more isolated ports and transferring the packets to 35
the one or more community ports, the primary VLAN
rejecting packets from the one or more isolated ports
and rejecting packets from the one or more community
ports;
means for receiving packets by an isolated VLAN, the 40
isolated VLAN receiving the packets from outside of
the router through an isolated port of the one or more
isolated ports and transferring the packets to the one or
more promiscuous ports, the isolated VLAN preventing
transfer of the packets from the isolated port to another 45
isolated port of the one or more isolated ports, and the
isolated VLAN preventing transfer of the packets from
the isolated port to the one or more community ports,
and the isolated VLAN rejecting packets from the one
or more promiscuous ports; and
means for receiving packets by a community VLAN, the 50
community VLAN receiving packets from outside of
the router at a community port of the one or more
community ports and transferring the packets to the one
or more promiscuous ports and transferring the packets
to any other community ports, the community VLAN 55
preventing transfer of packets to the one or more
isolated ports, and the community VLAN rejecting
packets from the one or more promiscuous ports.
30. The router as in claim 29 further comprising:
means for connecting a promiscuous port of the one or 60
more promiscuous ports to a shared network, the shared
network carrying packet traffic of a first user and packet
traffic of a second user; and
means for connecting a first isolated port of the one or
more isolated ports to a local area network (LAN) 65
assigned to the first user, and connecting a second
isolated port of the one or more isolated ports to a LAN

16

- assigned to the second user, in order to separate the
packet traffic of the first user and the second user.
31. The router as in claim 29 further comprising:
means for establishing a plurality of sets of community
ports; and
means for connecting a community VLAN for each set of
community ports, the community VLAN for a particu-
lar set of community ports preventing transfer of pack-
ets to another set of community ports.
32. The router as in claim 29 further comprising:
means for connecting a promiscuous port of the one or
more promiscuous ports to a shared network, the shared
network carrying packet traffic of a first user and packet
traffic of a second user; and
means for connecting a first set of community ports of the
one or more community ports to a local area network
(LAN) assigned to the first user, and connecting a
second set of community ports of the one or more
community ports connected to a LAN assigned to the
second user, in order to separate the packet traffic of the
first user and the second user.
33. A router, comprising:
means for establishing one or more promiscuous ports;
means for establishing one or more isolated ports;
means for receiving packets by a primary VLAN, the
primary VLAN receiving packets from outside of the
router through the one or more promiscuous ports and
transferring the packets to a selected one of the one or
more isolated ports, the primary VLAN rejecting
receive packets from the one or more isolated ports;
and
means for receiving packets by an isolated VLAN, the
isolated VLAN receiving packets from outside of the
router through an isolated port of the one or more
isolated ports and transferring the packets to the one or
more promiscuous ports, the isolated VLAN preventing
transfer of the packets from the isolated port to another
isolated port of the one or more isolated ports, and the
isolated VLAN rejecting packets from the one or more
promiscuous ports.
34. A router, comprising:
means for establishing one or more promiscuous ports;
means for establishing one or more community ports;
means for receiving packets by a primary VLAN, the
primary VLAN receiving packets from outside of the
router through the one or more promiscuous ports and
transferring the packets to the one or more community
ports, the primary VLAN rejecting packets from the
one or more community ports; and
means for receiving packets by a community VLAN, the
community VLAN receiving packets from outside the
router at a community port of the one or more com-
munity ports and transferring the packets to the one or
more promiscuous ports and transferring the packets to
any other community ports of the one or more com-
munity ports, the community VLAN rejecting packets
from the one or more promiscuous ports.
35. A router, comprising:
means for establishing one or more promiscuous ports;
means for establishing one or more other ports;
means for receiving packets by a primary VLAN, the
primary VLAN receiving packets from outside of the
router through the one or more promiscuous ports and
transferring the packets to a selected one of the one or
more other ports, the primary VLAN rejecting packets
from the one or more other ports; and

17

means for receiving packets by a second VLAN, the second VLAN receiving packets from outside the router at the one or more other ports and transferring the packets to the one or more promiscuous ports, the second VLAN rejecting packets from the one or more promiscuous ports.

36. The router as in claim **35**, further comprising: means for transferring the packets by the second VLAN to the one or more other ports.

37. The router as in claim **35**, further comprising: means for establishing the one or more other ports as one or more isolated ports.

38. The router as in claim **35**, further comprising: means for establishing the one or more other ports one or more a community ports.

39. A router to separate packet traffic traveling on a shared network, comprising:

a primary VLAN within the router, the primary VLAN to receive packets from the shared network through a promiscuous port and to transfer the packets to a selected one of a one or more isolated ports, the primary VLAN to reject packets from the one or more isolated ports, a first local area network (LAN) of a first user connected to a first isolated port of the one or more isolated ports, and a second LAN of a second user connected to a second isolated port of the one or more isolated ports; and

a first isolated VLAN within the router, the first isolated VLAN to receive packets through an isolated port connected to the first LAN and to transfer the packets to the promiscuous port, the first isolated VLAN to prevent transfer of the packets from the isolated port connected to the first LAN to another isolated port, and the isolated VLAN rejecting packets from the one or more promiscuous ports; and

a second isolated VLAN within the router, the second isolated VLAN to receive packets through an isolated port connected to the second LAN and to transfer the packets to the promiscuous port, the second isolated VLAN to prevent transfer of the packets from the isolated port connected to the second LAN to another isolated port, and the second isolated VLAN to reject packets from the promiscuous port.

40. A method in a router for separating packet traffic traveling on a shared network, comprising:

receiving packets by a primary VLAN within the router, the primary VLAN receiving packets from the shared network through a promiscuous port and transferring the packets to a selected one of a one or more isolated ports, the primary VLAN rejecting packets from the one or more isolated ports, a first local area network (LAN) of a first user connected to a first isolated port of the one or more isolated ports, and a second LAN of a second user connected to a second isolated port of the one or more isolated ports; and

receiving packets by a first isolated VLAN within the router, the first isolated VLAN receiving packets through an isolated port connected to the first LAN and transferring the packets to the promiscuous port, the first isolated VLAN preventing transfer of the packets from the isolated port connected to the first LAN to another isolated port, and the first isolated VLAN rejecting packets from the one or more promiscuous ports; and

receiving packets by a second isolated VLAN within the router, the second isolated VLAN receiving packets through an isolated port connected to the second LAN

18

and transferring the packets to the promiscuous port, the second isolated VLAN preventing-transfer of the packets from the isolated port connected to the second LAN to another isolated port, and the second isolated VLAN rejecting-packets from the promiscuous port.

41. A router to separate packet traffic traveling on a shared network, comprising:

means for receiving packets by a primary VLAN within the router, the primary VLAN receiving packets from the shared network through a promiscuous port and transferring the packets to a selected one of a one or more isolated ports, the primary VLAN rejecting packets from the one or more isolated ports, a first local area network (LAN) of a first user connected to a first isolated port of the one or more isolated ports, and a second LAN of a second user connected to a second isolated port of the one or more isolated ports; and

means for receiving packets by a first isolated VLAN within the router, the first isolated VLAN receiving packets through an isolated port connected to the first LAN and transferring the packets to the promiscuous port, the first isolated VLAN preventing transfer of the packets from the isolated port connected to the first LAN to another isolated port, and the first isolated VLAN rejecting packets from the one or more promiscuous ports; and

means for receiving packets by a second isolated VLAN within the router, the second isolated VLAN receiving packets through an isolated port connected to the second LAN and transferring the packets to the promiscuous port, the second isolated VLAN preventing-transfer of the packets from the isolated port connected to the second LAN to another isolated port, and the second isolated VLAN rejecting-packets from the promiscuous port.

42. A router to separate packet traffic traveling on a shared network, comprising:

a primary VLAN within the router, the primary VLAN to receive packets from the shared network through a promiscuous port and to transfer the packets to a selected one of a one or more community ports, the primary VLAN to reject packets from the one or more community ports, a first group of local area network (LAN) of a first user connected to a first group of community ports of the one or more community ports, and a second group of LANs of a second user connected to a second group of community ports of the one or more community ports;

a first community VLAN within the router, the first community VLAN to receive packets through the first group of community ports connected to the first group of LANs and to transfer the packets to the promiscuous port, the first community VLAN prevent transfer of the packets from the first group of community ports to the second group of community ports, and the first community VLAN to reject packets from the one or more promiscuous ports; and

a second community VLAN within the router, the second community VLAN to receive packets through the second group of community ports connected to the second group of LANs and to transfer the packets to the promiscuous port, the second community VLAN to prevent transfer of the packets to the first group of community ports, and the second community VLAN to reject packets from the promiscuous port.

43. A method for separating packet traffic traveling on a shared network, comprising:

receiving packets from the shared network by a primary VLAN within the router, the primary VLAN receiving packets from the shared network through a promiscuous port and transferring the packets to a selected one of a one or more community ports, the primary VLAN rejecting packets from the one or more community ports, a first group of local area network (LAN) of a first user connected to a first group of community ports of the one or more community ports, and a second group of LANs of a second user connected to a second group of community ports of the one or more community ports;

receiving packets from a first group of community ports by a first community VLAN within the router, the first community VLAN receiving packets through the first group of community ports connected to the first group of LANs and transferring the packets to the promiscuous port, the first community VLAN preventing transfer of the packets from the first group of community ports to the second group of community ports, and the first community VLAN rejecting packets from the one or more promiscuous ports; and

receiving packets from a second group of community ports by a second community VLAN within the router, the second community VLAN receiving packets through the second group of community ports connected to the second group of LANs and transferring the packets to the promiscuous port, the second community VLAN preventing transfer of the packets to the first group of community ports, and the second community VLAN rejecting packets from the promiscuous port.

44. A router to separate packet traffic traveling on a shared network, comprising:

means for receiving packets from the shared network by a primary VLAN within the router, the primary VLAN receiving packets from the shared network through a promiscuous port and transferring the packets to a selected one of a one or more community ports, the primary VLAN rejecting packets from the one or more community ports, a first group of local area network (LAN) of a first user connected to a first group of community ports of the one or more community ports, and a second group of LANs of a second user connected to a second group of community ports of the one or more community ports;

means for receiving packets from a first group of community ports by a first community VLAN within the router, the first community VLAN receiving packets through the first group of community ports connected to the first group of LANs and transferring the packets

to the promiscuous port, the first community VLAN preventing transfer of the packets from the first group of community ports to the second group of community ports, and the first community VLAN rejecting packets from the one or more promiscuous ports; and

means for receiving packets from a second group of community ports by a second community VLAN within the router, the second community VLAN receiving packets through the second group of community ports connected to the second group of LANs and transferring the packets to the promiscuous port, the second community VLAN preventing transfer of the packets to the first group of community ports, and the second community VLAN rejecting packets from the promiscuous port.

45. A computer readable medium containing executable program instructions for operating a router, the executable program instructions comprising program instructions configured to:

establish a first VLAN from a port connected to a shared network to a plurality of user ports, the first VLAN to receive packets from the shared network and to transfer them to one or more of the user ports, the first VLAN to reject any packets received from the user ports;

establish a second VLAN from the plurality of user ports, the second VLAN to receive packets from the user ports and to transfer them to the port connected to the shared network, the second VLAN to prevent transfer of packets from one of the user ports to other user ports, and the second VLAN also to reject packets from the shared network, to thereby separate packet traffic of different users.

46. A computer readable medium containing executable program instructions for operating a router, the executable program instructions comprising program instructions configured to:

establish a primary VLAN, the primary VLAN to receive packets from outside of the router through the one or more promiscuous ports and to transfer the packets to one or more community ports, the primary VLAN to reject packets received from the one or more community ports; and

establish a community VLAN, the community VLAN to receive packets from outside the router on a community port of the one or more community ports and to transfer the packets to the one or more promiscuous ports and to transfer the packets to any other community ports of the one or more community ports, the community VLAN rejecting packets received from the one or more promiscuous ports.

* * * * *

UNITED STATES PATENT AND TRADEMARK OFFICE
CERTIFICATE OF CORRECTION

PATENT NO. : 7,200,145 B1
APPLICATION NO. : 10/840212
DATED : April 3, 2007
INVENTOR(S) : Thomas Edsall et al.

Page 1 of 1

It is certified that error appears in the above-identified patent and that said Letters Patent is hereby corrected as shown below:

Title Page,
Item [63], Related U.S. Application Data: should be added and read -- Continuation of Application No. 09/575,774, filed on May 22, 2000, now Pat. No. 6,741,592. --

Signed and Sealed this

Eighteenth Day of March, 2008

A handwritten signature in black ink that reads "Jon W. Dudas". The signature is written in a cursive style with a large, looped initial "J".

JON W. DUDAS

Director of the United States Patent and Trademark Office

UNITED STATES PATENT AND TRADEMARK OFFICE
CERTIFICATE OF CORRECTION

PATENT NO. : 7,200,145 B1
APPLICATION NO. : 10/840212
DATED : April 3, 2007
INVENTOR(S) : Thomas Edsall et al.

Page 1 of 1

It is certified that error appears in the above-identified patent and that said Letters Patent is hereby corrected as shown below:

At Column 1, line 2, after the heading "PRIVATE VLANS" text should be added and read -- This Application is a continuation of Application Serial No. 09/575,774, filed on May 22, 2000, now issued as Patent No. 6,741,592. --

Signed and Sealed this
Twenty-eighth Day of December, 2010

A handwritten signature in black ink that reads "David J. Kappos". The signature is written in a cursive style with a large initial "D" and "K".

David J. Kappos
Director of the United States Patent and Trademark Office