



US007186262B2

(12) **United States Patent**
Saadat

(10) **Patent No.:** **US 7,186,262 B2**
(45) **Date of Patent:** ***Mar. 6, 2007**

(54) **APPARATUS AND METHODS FOR TREATING TISSUE**

(76) Inventor: **Vahid Saadat**, 12679 Kane Dr., Saratoga, CA (US) 95070

(*) Notice: Subject to any disclaimer, the term of this patent is extended or adjusted under 35 U.S.C. 154(b) by 101 days.

This patent is subject to a terminal disclaimer.

(21) Appl. No.: **10/188,509**

(22) Filed: **Jul. 3, 2002**

(65) **Prior Publication Data**

US 2003/0018358 A1 Jan. 23, 2003

Related U.S. Application Data

(63) Continuation-in-part of application No. 09/898,726, filed on Jul. 3, 2001, now Pat. No. 6,626,899, which is a continuation-in-part of application No. 09/602,436, filed on Jun. 23, 2000, now Pat. No. 6,669,687.

(60) Provisional application No. 60/141,077, filed on Jun. 25, 1999.

(51) **Int. Cl.**

A61B 17/04 (2006.01)

A61F 2/06 (2006.01)

(52) **U.S. Cl.** **606/232; 606/151; 606/153; 623/1.26**

(58) **Field of Classification Search** **606/7, 606/13, 14, 22-29, 32, 41-52, 76-78, 151, 606/153-159, 205-209, 232; 607/96-101, 607/88, 89, 115, 116, 119, 9, 14; 600/372-375; 604/915-921; 623/1.1, 1.18, 1.26, 1.3, 1.34, 623/1.36-1.38, 1.46, 2.1-2.14**

See application file for complete search history.

(56) **References Cited**

U.S. PATENT DOCUMENTS

3,166,072 A 1/1965 Sullivan, Jr.

(Continued)

FOREIGN PATENT DOCUMENTS

WO WO 90/09763 9/1990

(Continued)

OTHER PUBLICATIONS

Hayashi, K. et al. (1997). "The Effect of Thermal Heating on the Length and Histologic Properties of the Glenohumeral Joint Capsule", *The American Journal of Sports Medicine*, 25(1):107-112.

(Continued)

Primary Examiner—A. Farah

(74) *Attorney, Agent, or Firm*—Levine Bagade Han LLP

(57) **ABSTRACT**

Apparatus and methods are provided for thermally and/or mechanically treating tissue, such as valvular structures, to reconfigure or shrink the tissue in a controlled manner. Mechanical clips are implanted over the leaflets of a valve, e.g., in the heart, either alone or after thermal treatment to cause the valve to close more tightly. The clips are delivered by a catheter and may be configured to traverse directly over the valve itself or to lie partially over the periphery of the valve to prevent obstruction of the valve channel. The clips can be coated with drugs or a radiopaque coating. Alternatively, individual anchors with a tensioning element, like a suture, may be used to approximate the valves towards each other. The catheter can also incorporate sensors or energy delivery devices, e.g., transducers, on its distal end.

29 Claims, 46 Drawing Sheets

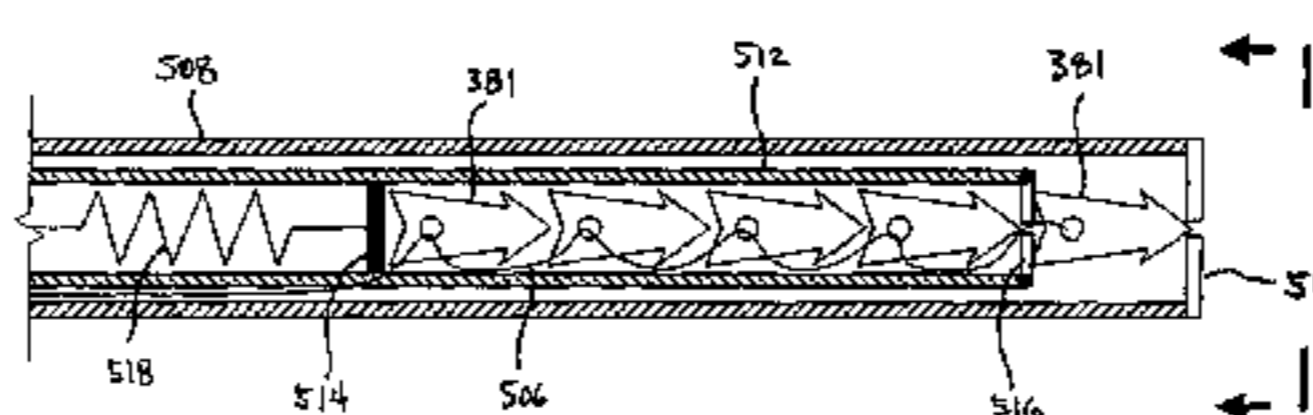
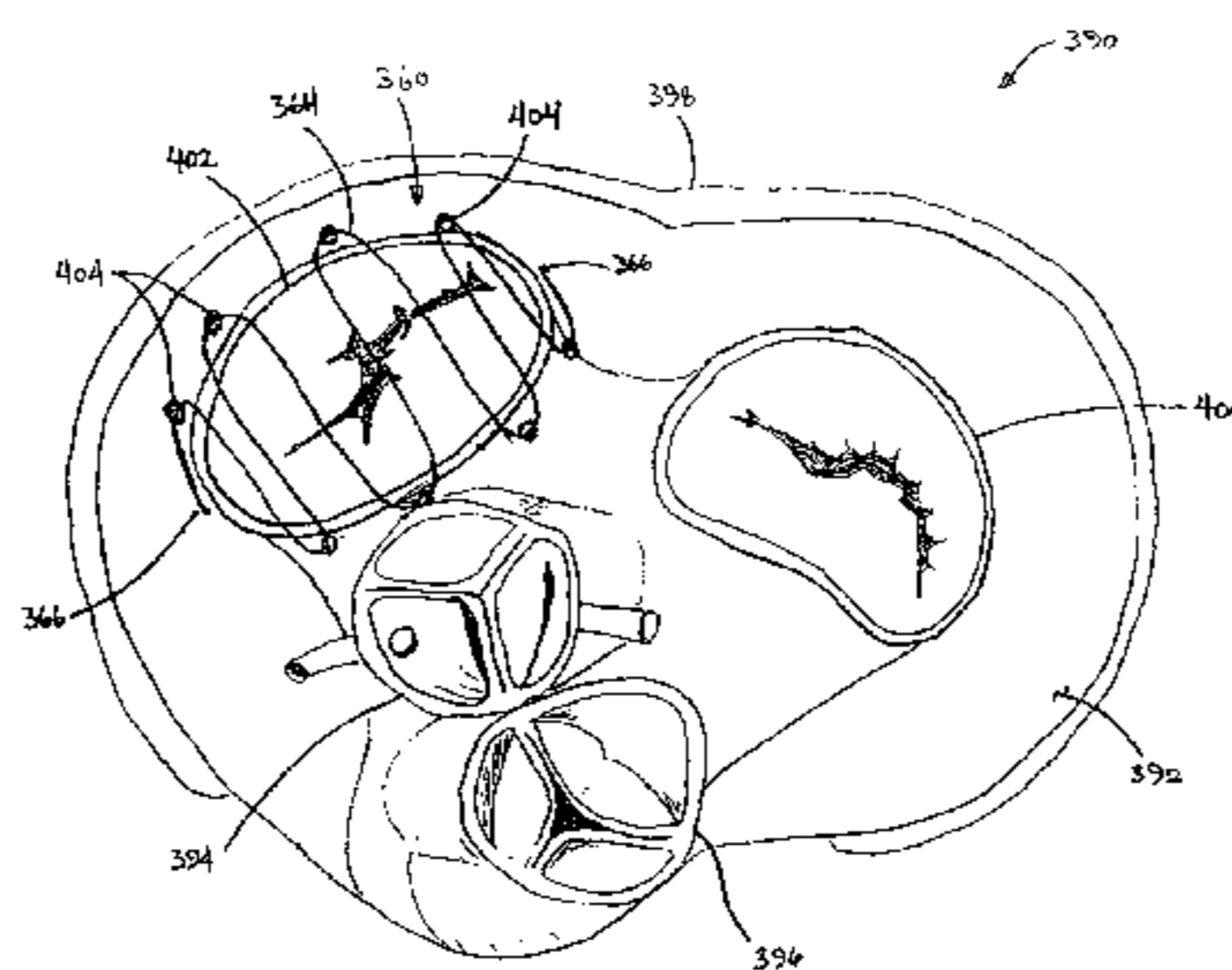

US 7,186,262 B2

U.S. PATENT DOCUMENTS							
3,704,711	A	12/1972	Park	5,632,752	A	5/1997	Buelna
4,204,283	A	5/1980	Bellhouse et al.	5,639,276	A	6/1997	Weinstock et al.
4,259,959	A	4/1981	Walker	5,643,317	A	7/1997	Pavcnik et al.
4,492,229	A	1/1985	Grunwald	5,643,320	A	7/1997	Lower et al.
4,524,771	A	6/1985	McGregor et al.	5,662,654	A *	9/1997	Thompson 606/72
4,639,252	A	1/1987	Kelly et al.	5,662,663	A	9/1997	Shallman
4,655,773	A	4/1987	Grassi	5,662,683	A	9/1997	Kay
4,731,075	A	3/1988	Gallo Mezo et al.	5,667,513	A	9/1997	Torrie et al.
4,816,339	A	3/1989	Tu et al.	5,673,695	A	10/1997	McGee et al.
4,841,888	A	6/1989	Mills et al.	5,679,005	A	10/1997	Einstein
4,938,760	A	7/1990	Burton et al.	5,683,402	A	11/1997	Cosgrove et al.
5,013,316	A	5/1991	Goble et al.	5,700,273	A	12/1997	Buelna et al.
5,059,201	A	10/1991	Asnis	5,702,421	A	12/1997	Schneidt
5,101,592	A *	4/1992	Merritt 43/43.13	5,713,903	A	2/1998	Sander et al.
5,108,420	A	4/1992	Marks	5,720,753	A	2/1998	Sander et al.
5,125,926	A	6/1992	Rudko et al.	5,724,978	A	3/1998	Tenhoff
5,171,252	A	12/1992	Friedland	5,725,521	A *	3/1998	Muller 606/7
5,222,508	A	6/1993	Contarini	5,725,552	A	3/1998	Kotula et al.
5,224,946	A	7/1993	Hayhurst et al.	5,732,707	A	3/1998	Widder et al.
5,236,445	A	8/1993	Hayhurst et al.	5,741,297	A	4/1998	Simon
5,258,016	A	11/1993	DiPoto et al.	5,752,963	A	5/1998	Allard et al.
5,275,162	A	1/1994	Edwards et al.	5,766,234	A	6/1998	Chen et al.
5,281,218	A	1/1994	Imran	5,769,846	A	6/1998	Edwards et al.
5,284,488	A	2/1994	Sideris	5,776,189	A	7/1998	Khalid
5,290,300	A	3/1994	Cosgrove et al.	5,779,719	A	7/1998	Klein et al.
5,304,184	A	4/1994	Hathaway et al.	5,792,152	A	8/1998	Klein et al.
5,334,217	A	8/1994	Das	5,797,960	A	8/1998	Stevens et al.
5,336,252	A	8/1994	Cohen	5,810,847	A	9/1998	Laufer et al.
5,354,298	A	10/1994	Lee et al.	5,810,849	A	9/1998	Kontos
5,374,275	A	12/1994	Bradley et al.	5,814,070	A	9/1998	Borzzone et al.
5,380,334	A	1/1995	Torrie et al.	5,817,110	A	10/1998	Kronner
5,383,897	A	1/1995	Wholey	5,823,342	A	10/1998	Caudillo et al.
5,403,329	A	4/1995	Hinchcliffe	5,823,956	A	10/1998	Roth et al.
5,417,699	A	5/1995	Klein et al.	5,824,067	A	10/1998	Gross
5,423,856	A	6/1995	Green	5,827,203	A	10/1998	Nita
5,425,744	A	6/1995	Fagan et al.	5,827,268	A	10/1998	Laufer
5,431,666	A	7/1995	Sauer et al.	5,829,447	A	11/1998	Stevens et al.
5,433,727	A	7/1995	Sideris	5,830,145	A	11/1998	Tenhoff
5,443,446	A	8/1995	Shturman	5,836,955	A	11/1998	Buelna et al.
5,450,860	A	9/1995	O'Connor	5,846,261	A	12/1998	Kotula et al.
5,454,807	A	10/1995	Lennox et al.	D404,128	S	1/1999	Huebner
5,458,609	A	10/1995	Gordon et al.	5,855,552	A	1/1999	Houser et al.
5,462,560	A	10/1995	Stevens	5,855,614	A	1/1999	Stevens et al.
5,462,561	A	10/1995	Voda	5,860,920	A	1/1999	McGee et al.
5,470,338	A	11/1995	Whitfield et al.	5,860,991	A	1/1999	Klein et al.
5,476,470	A	12/1995	Fitzgibbons, Jr.	5,861,003	A	1/1999	Latson et al.
5,480,403	A	1/1996	Lee et al.	5,868,749	A	2/1999	Reed
5,489,298	A	2/1996	Love et al.	5,868,762	A	2/1999	Cragg et al.
5,489,498	A	2/1996	Ohno et al.	5,888,247	A	3/1999	Benetti
5,492,119	A	2/1996	Abrams	5,895,404	A	4/1999	Ruiz
5,496,332	A	3/1996	Sierra et al.	5,910,155	A	6/1999	Ratcliff et al.
5,496,336	A	3/1996	Cosgrove et al.	5,928,224	A	7/1999	Laufer
5,499,991	A	3/1996	Garman et al.	5,928,244	A	7/1999	Tovey et al.
5,501,691	A	3/1996	Goldrath	5,944,738	A	8/1999	Amplatz et al.
5,507,811	A	4/1996	Koike et al.	5,944,739	A	8/1999	Zlock et al.
5,520,700	A *	5/1996	Beyar et al. 606/139	5,947,125	A	9/1999	Benetti
5,527,321	A	6/1996	Hinchcliffe	5,947,997	A	9/1999	Pavcnick et al.
5,527,322	A	6/1996	Klein et al.	5,948,000	A	9/1999	Larsen et al.
5,527,342	A *	6/1996	Pietrzak et al. 606/232	5,948,001	A	9/1999	Larsen
5,540,704	A	7/1996	Gordon et al.	5,954,732	A	9/1999	Hart et al.
5,542,917	A	8/1996	Nita et al.	5,957,916	A	9/1999	Jeevanandam et al.
5,562,686	A	10/1996	Sauer et al.	5,968,047	A	10/1999	Reed
5,562,688	A	10/1996	Riza	5,972,030	A	10/1999	Garrison et al.
5,573,540	A	11/1996	Yoon	5,989,284	A	11/1999	Laufer
5,578,045	A	11/1996	Das	5,993,459	A	11/1999	Larsen et al.
5,582,616	A *	12/1996	Bolduc et al. 606/143	5,997,534	A	12/1999	Tu et al.
5,584,859	A	12/1996	Brotz	5,997,554	A *	12/1999	Thompson 606/148
5,601,558	A	2/1997	Torrie et al.	6,004,269	A *	12/1999	Crowley et al. 600/439
5,609,598	A	3/1997	Laufer et al.	6,010,531	A	1/2000	Donlon et al.
5,613,974	A	3/1997	Andreas et al.	6,012,457	A	1/2000	Lesh
5,613,975	A	3/1997	Christy	6,013,083	A	1/2000	Bennett
				6,014,589	A	1/2000	Farley et al.
				6,019,768	A	2/2000	Wenstrom, Jr. et al.

US 7,186,262 B2

6,036,690 A	3/2000	De La Plaza Fernandez	6,472,983 B1 *	10/2002	Grunder 340/540
6,056,743 A	5/2000	Ellis et al.	6,547,787 B1 *	4/2003	Altman et al. 606/41
6,068,648 A	5/2000	Cole et al.	6,592,610 B2 *	7/2003	Beyar 606/232
6,074,395 A	6/2000	Trott et al.	6,599,310 B2 *	7/2003	Leung et al. 606/228
6,077,281 A	6/2000	Das	6,616,684 B1 *	9/2003	Vidlund et al. 606/213
6,077,291 A	6/2000	Das	6,619,291 B2	9/2003	Hlavka et al.
6,079,414 A	6/2000	Roth	6,626,899 B2 *	9/2003	Houser et al. 606/14
6,086,591 A	7/2000	Bojarski	6,629,534 B1	10/2003	St. Goar et al.
6,086,612 A	7/2000	Jansen	6,702,826 B2	3/2004	Liddicoat et al.
6,096,060 A	8/2000	Fitts et al.	6,718,985 B2	4/2004	Hlavka et al.
6,113,631 A	9/2000	Jansen	6,746,472 B2 *	6/2004	Frazier et al. 606/232
6,120,453 A	9/2000	Sharp	7,087,064 B1 *	8/2006	Manker et al. 606/142
6,126,682 A	10/2000	Sharkey et al.	2002/0035361 A1	3/2002	Houser et al.
6,146,387 A	11/2000	Trott et al.	2002/0087048 A1	7/2002	Brock et al.
6,149,660 A	11/2000	Laufer et al.	2002/0087049 A1	7/2002	Brock et al.
6,152,144 A	11/2000	Lesh	2002/0087166 A1	7/2002	Brock et al.
6,152,935 A	11/2000	Kammerer et al.	2002/0087169 A1	7/2002	Brock et al.
6,159,235 A	12/2000	Kim	2002/0095167 A1	7/2002	Liddicoat et al.
6,161,543 A	12/2000	Cox et al.	2002/0095175 A1	7/2002	Brock et al.
6,165,183 A	12/2000	Kuehn et al.	2002/0161378 A1	10/2002	Downing
6,167,889 B1	1/2001	Benetti	2003/0233142 A1	12/2003	Morales et al.
6,174,287 B1	1/2001	Resnick et al.	2004/0019378 A1	1/2004	Hlavka et al.
6,187,040 B1	2/2001	Wright	2004/0024414 A1	2/2004	Downing
6,206,886 B1	3/2001	Bennett	2004/0133192 A1	7/2004	Houser
6,231,561 B1	5/2001	Frazier et al.			
6,245,079 B1	6/2001	Nobles et al.			
6,269,819 B1 *	8/2001	Oz et al. 128/898	WO	WO 98/32401	7/1998
6,270,515 B1	8/2001	Linden et al.	WO	WO 98/35638	8/1998
6,280,448 B1	8/2001	Trott et al.	WO	WO 99/02096	1/1999
6,283,962 B1	9/2001	Tu et al.	WO	WO 00/27292	11/2000
6,283,993 B1	9/2001	Cosgrove et al.	WO	WO 01/00114	1/2001
6,290,674 B1	9/2001	Roue et al.	WO	WO 01/26557	4/2001
6,290,702 B1	9/2001	Fucci et al.	WO	WO 03/003930	1/2003
6,306,133 B1	10/2001	Tu et al.	WO	WO 03/105670	12/2003
6,311,623 B1	11/2001	Zaruba			
6,319,270 B1	11/2001	Nagaoka			
6,332,468 B1	12/2001	Benetti			
6,334,873 B1	1/2002	Lane et al.			
6,344,053 B1	2/2002	Boneau			
6,346,074 B1	2/2002	Roth			
6,346,109 B1	2/2002	Fucci et al.			
6,355,030 B1	3/2002	Aldrich et al.			
6,355,052 B1	3/2002	Neuss et al.			
6,363,940 B1	4/2002	Krag			
6,368,339 B1	4/2002	Amplatz			
6,440,154 B2 *	8/2002	Gellman et al. 606/232			
6,451,024 B1 *	9/2002	Thompson et al. 606/104			

FOREIGN PATENT DOCUMENTS

WO	WO 98/32401	7/1998
WO	WO 98/35638	8/1998
WO	WO 99/02096	1/1999
WO	WO 00/27292	11/2000
WO	WO 01/00114	1/2001
WO	WO 01/26557	4/2001
WO	WO 03/003930	1/2003
WO	WO 03/105670	12/2003

OTHER PUBLICATIONS

Naseef III, G. S. et al. (1997). "The Thermal Properties of Bovine Joint Capsule, The Basic Science of Laser -and Radiofrequency-Induced Capsular Shrinkage", *The American Journal of Sports Medicine*, 25(5):670-674.

Selecky, M. T. et al. (1996). "The Effects of Laser-Induced Collagen Shortening on the Biomechanical Properties of the Inferior Glenohumeral Ligament Complex", University of Southern California, School of Medicine, Department of Orthopaedic Surgery, Los Angeles, California, 90033, pp. 1-25.

* cited by examiner

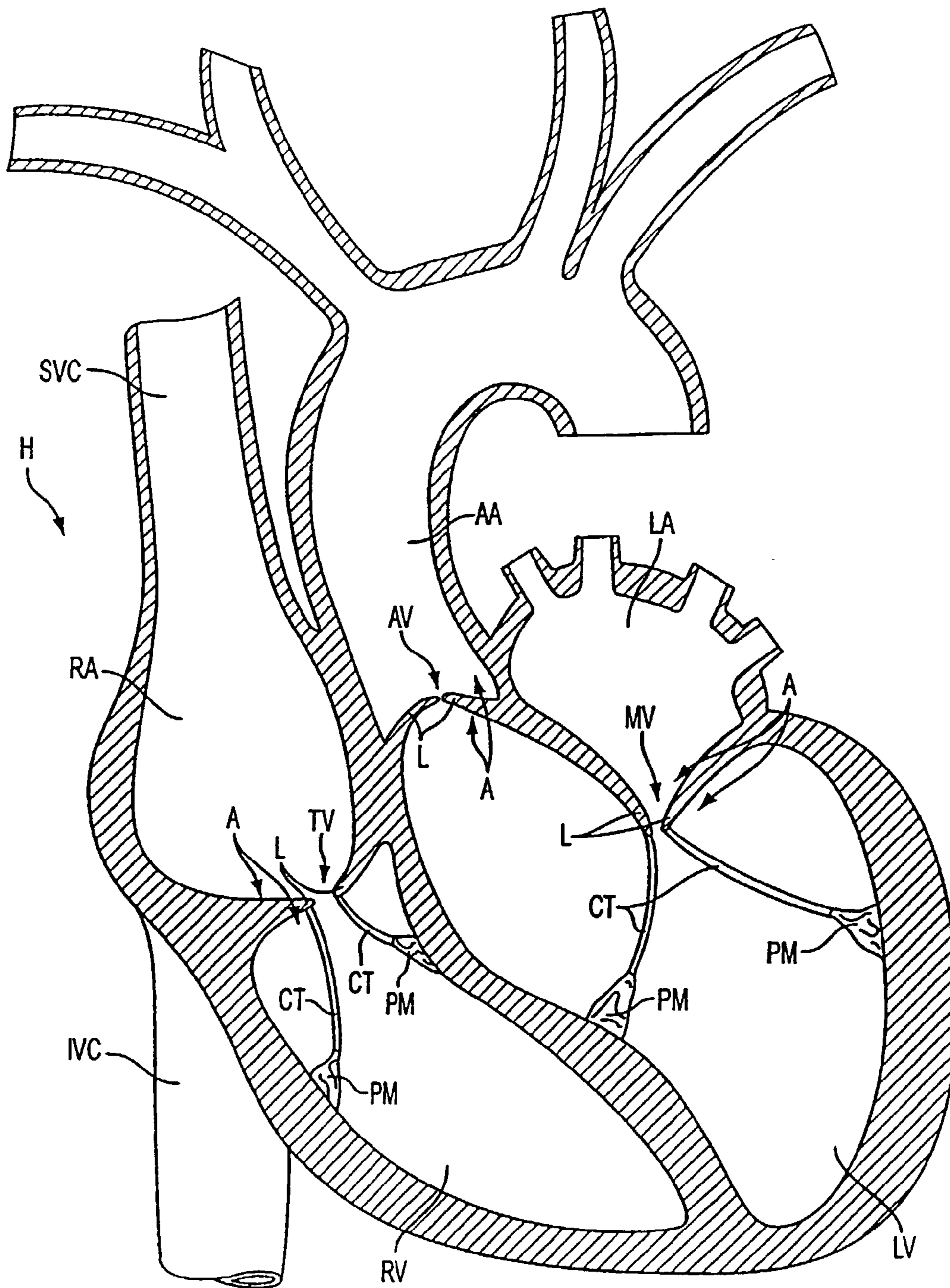

FIG. 1

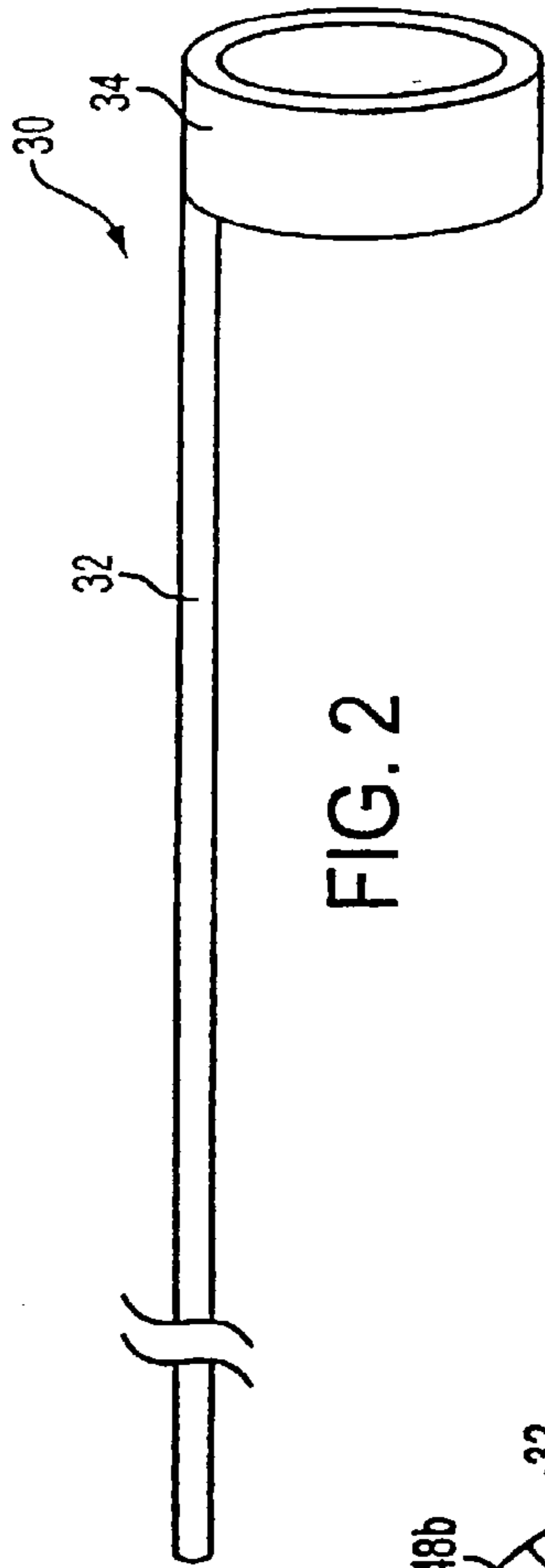

FIG. 2

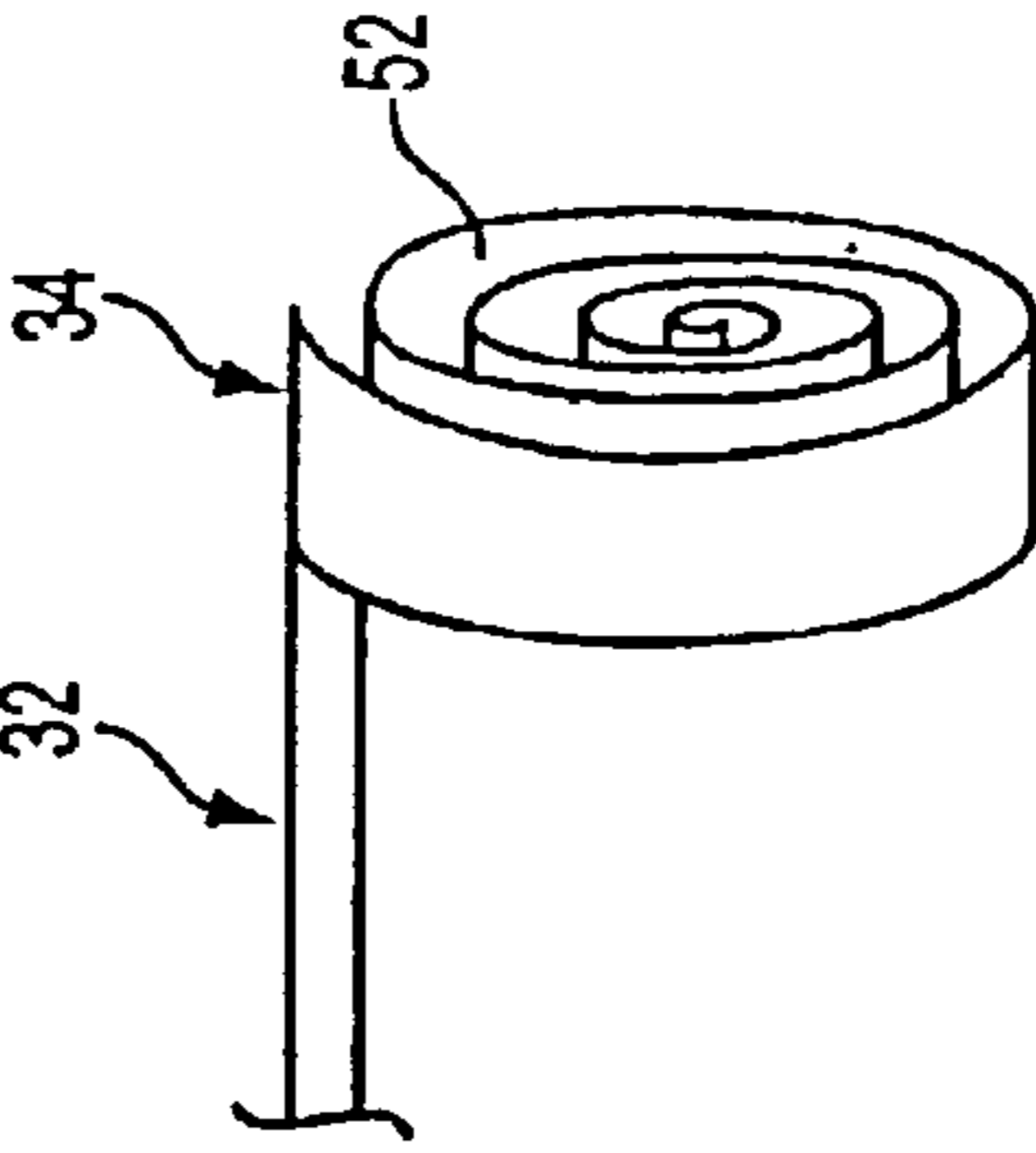
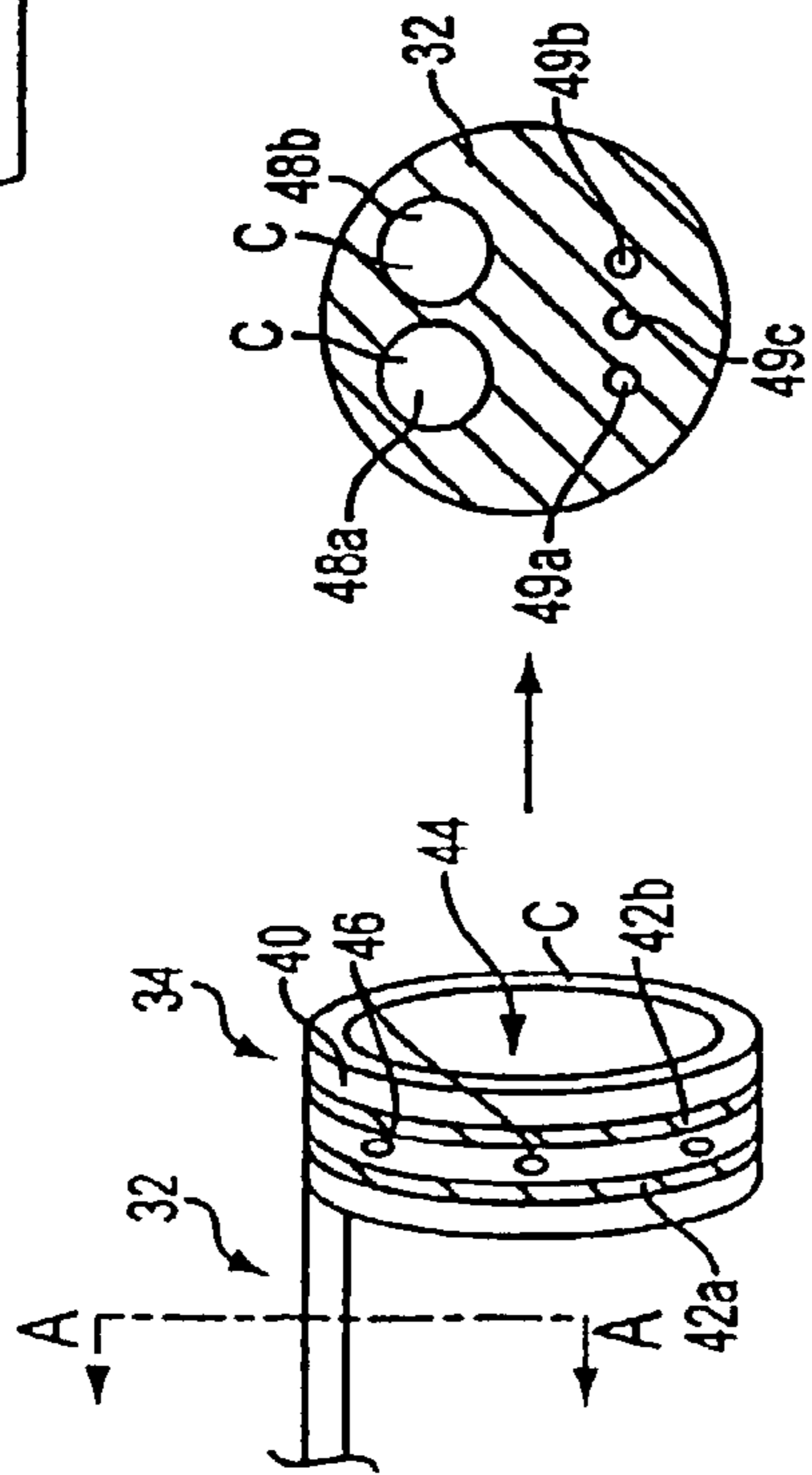

FIG. 3C

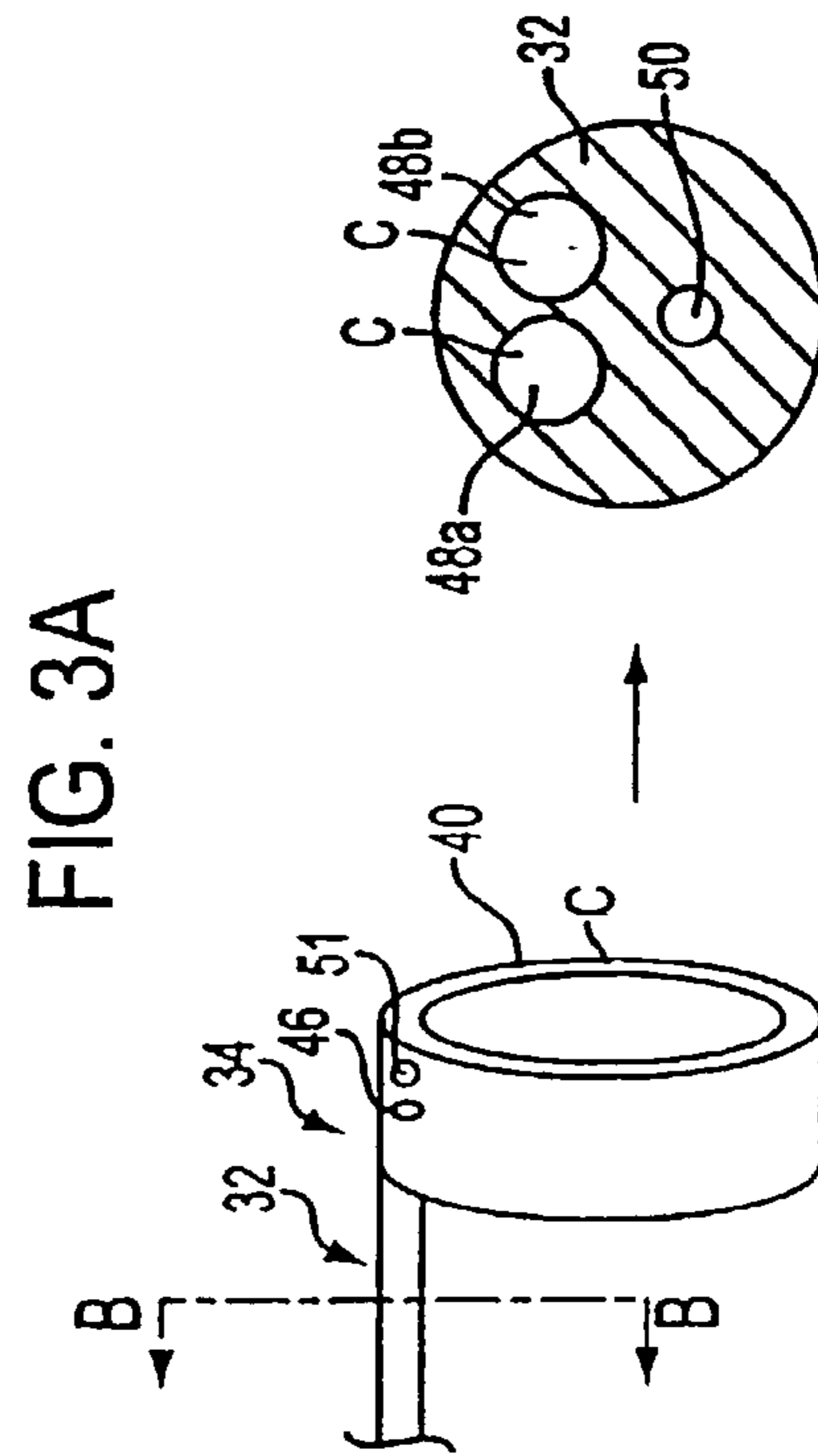

FIG. 3A

FIG. 3B

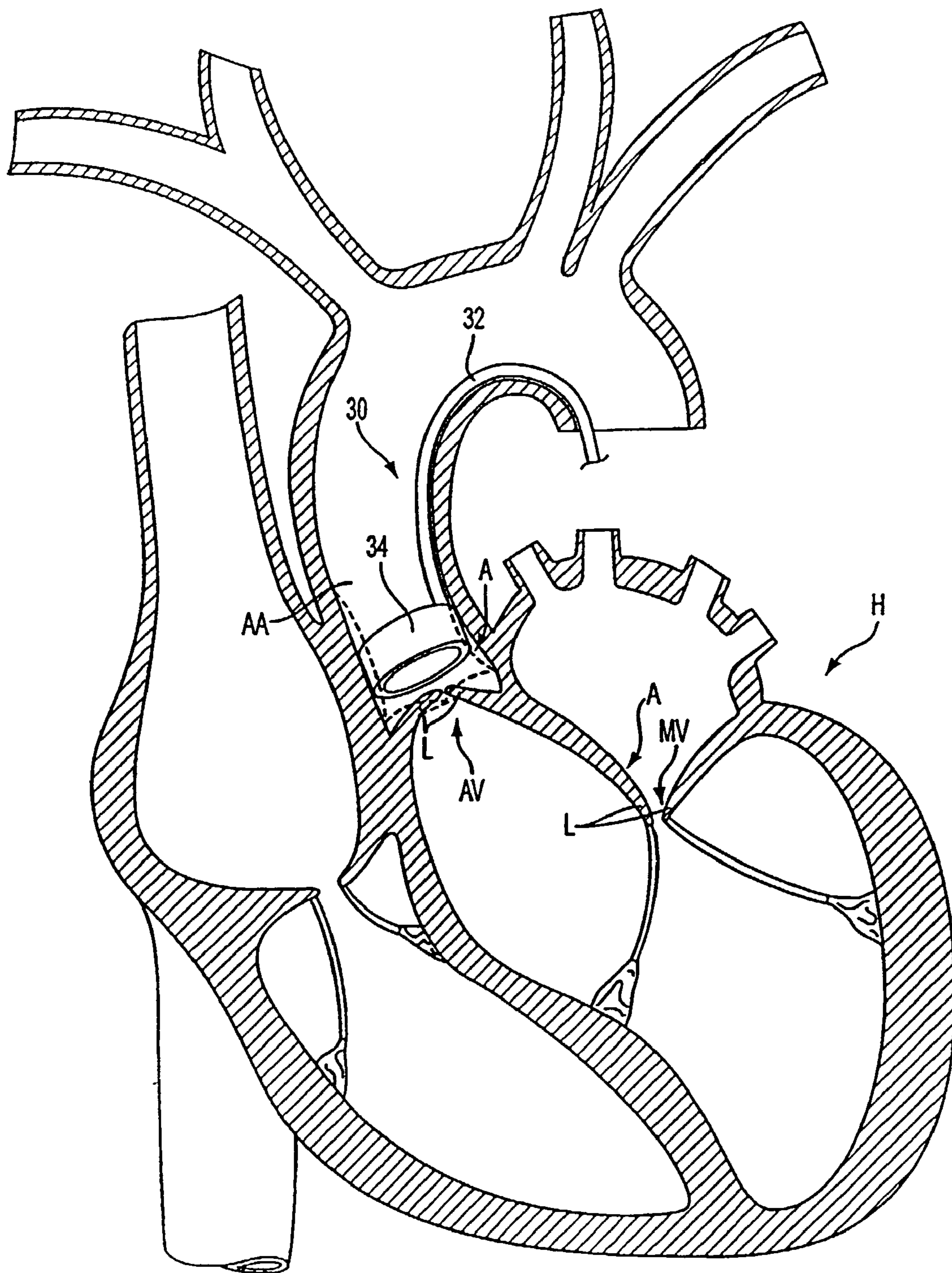

FIG. 4

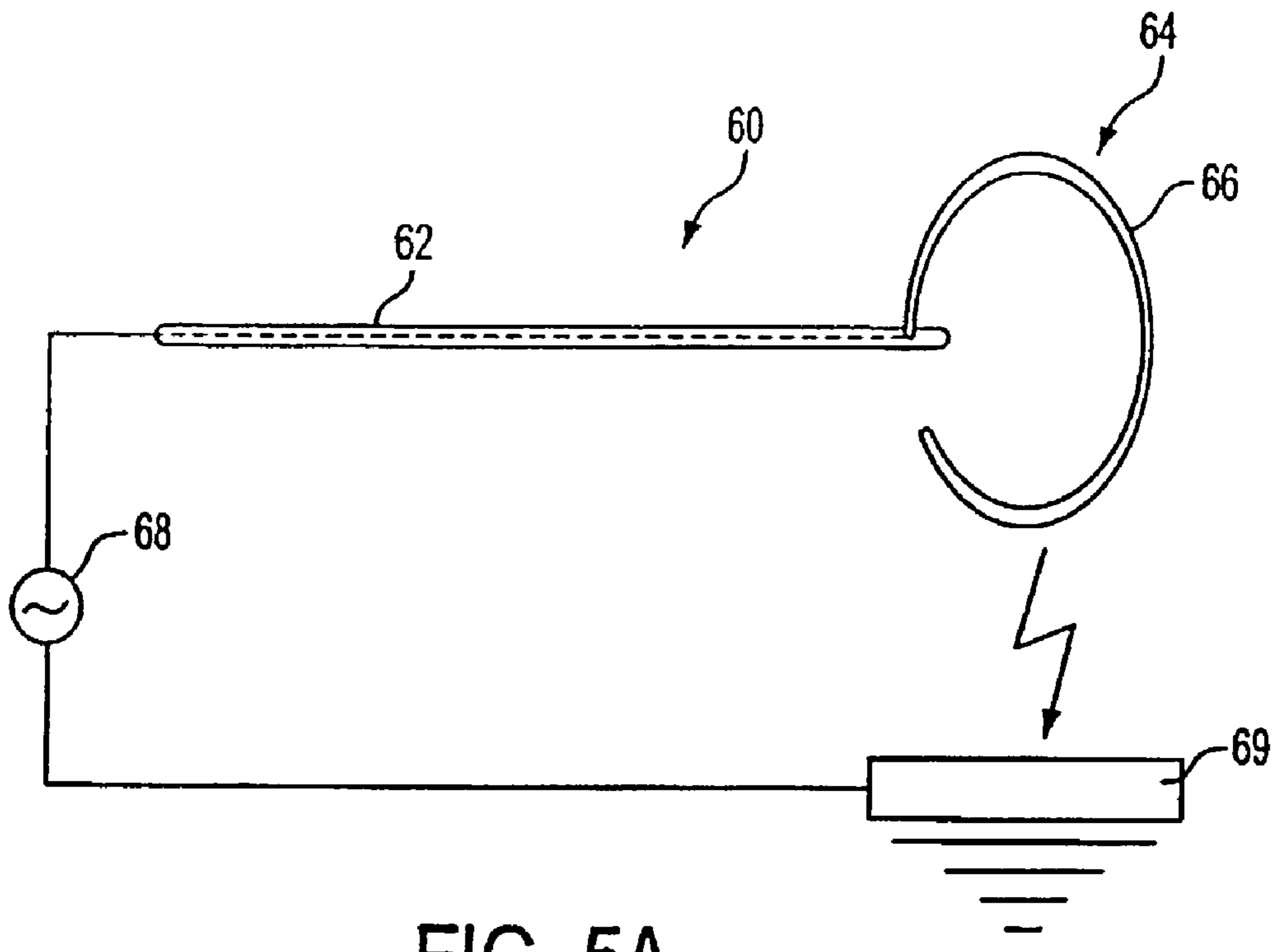

FIG. 5A

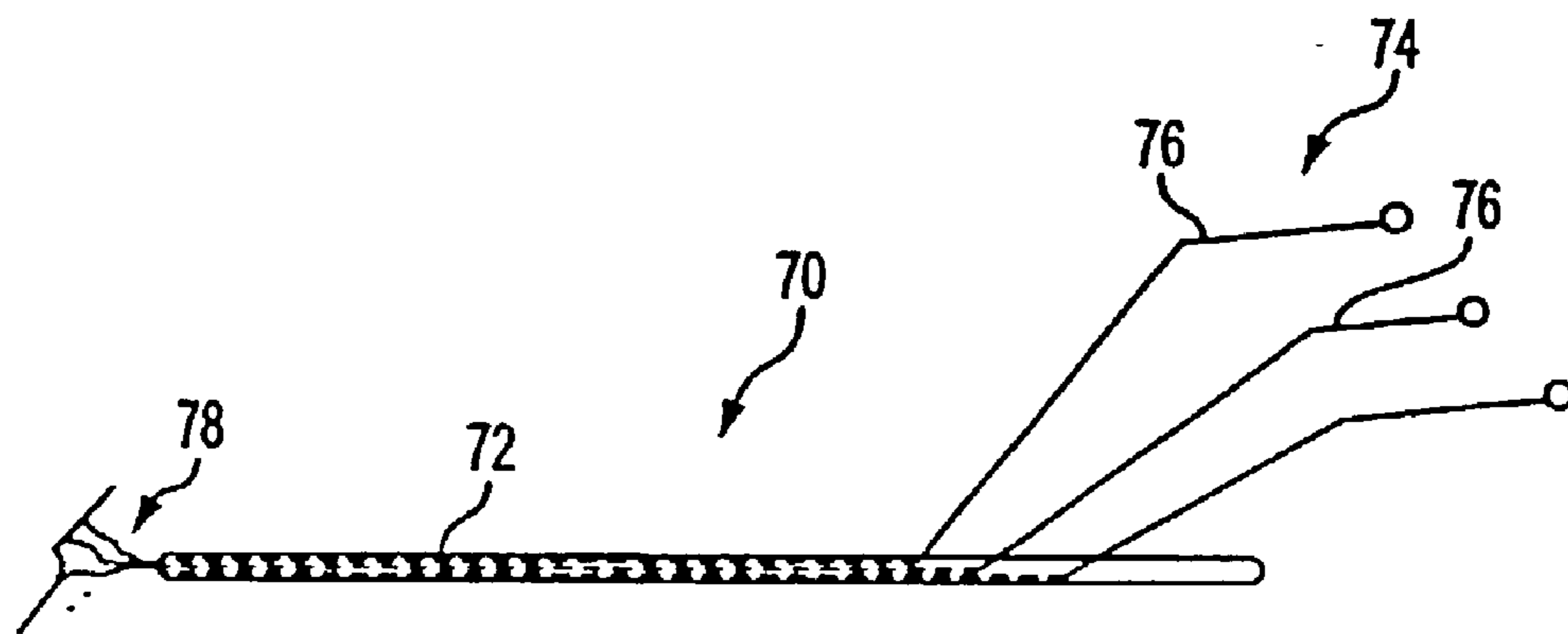

FIG. 5B

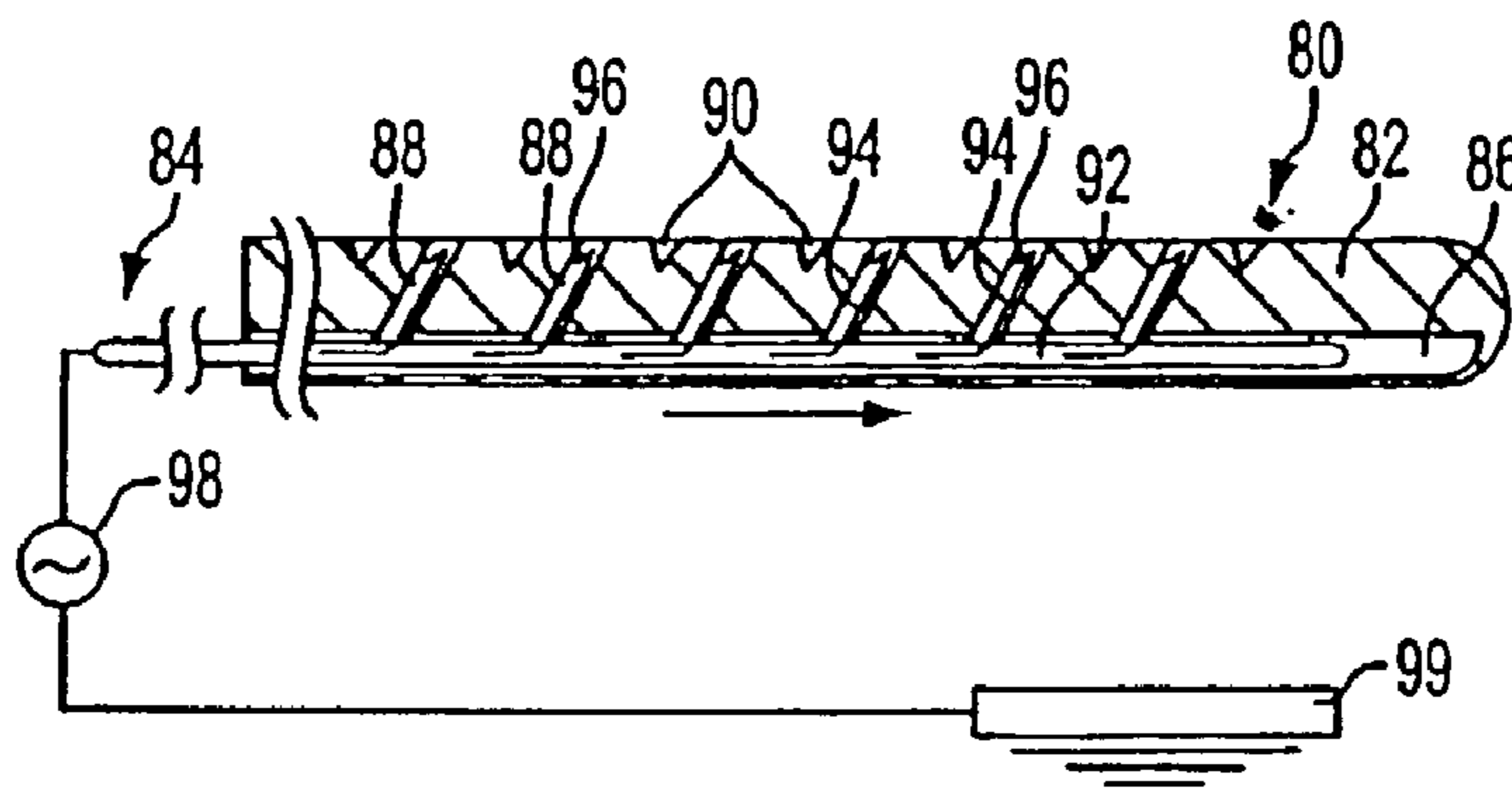

FIG. 6A

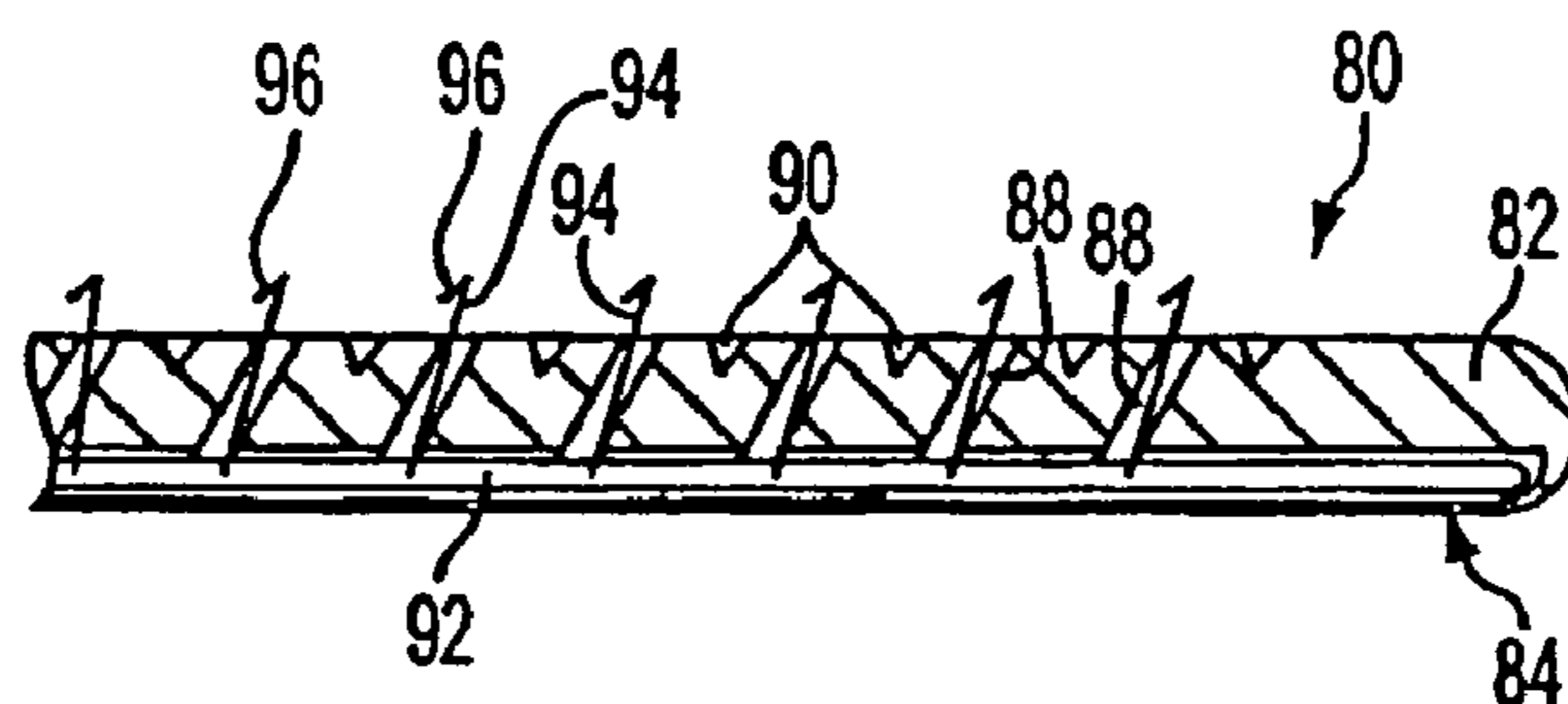

FIG. 6B

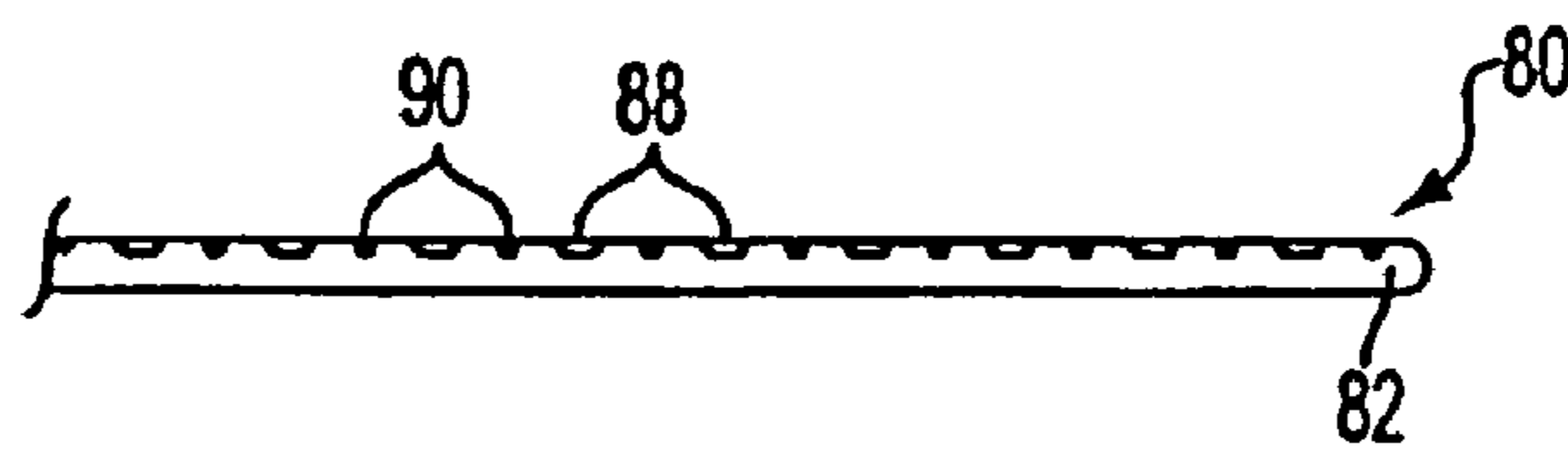

FIG. 6C

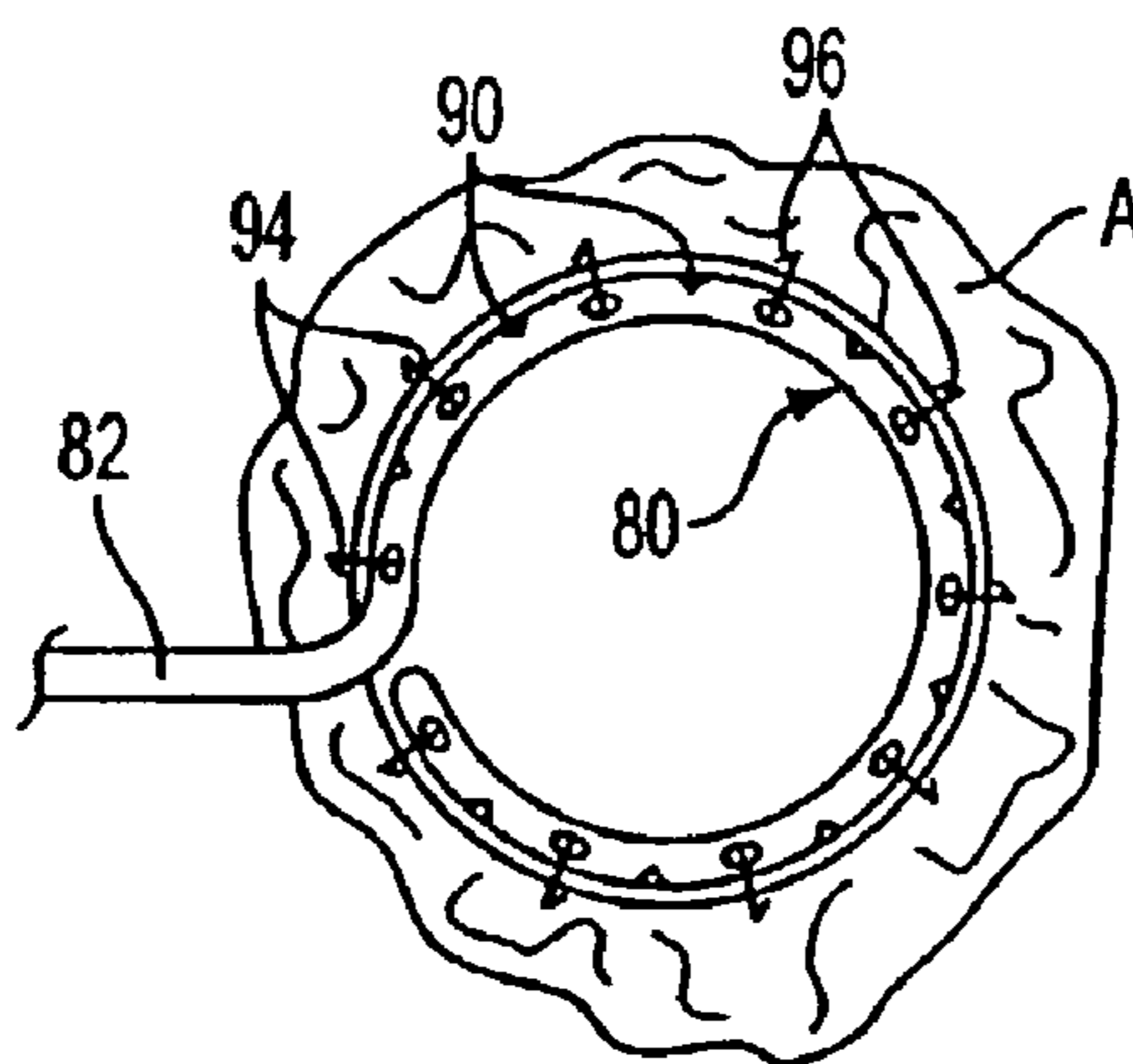

FIG. 6D

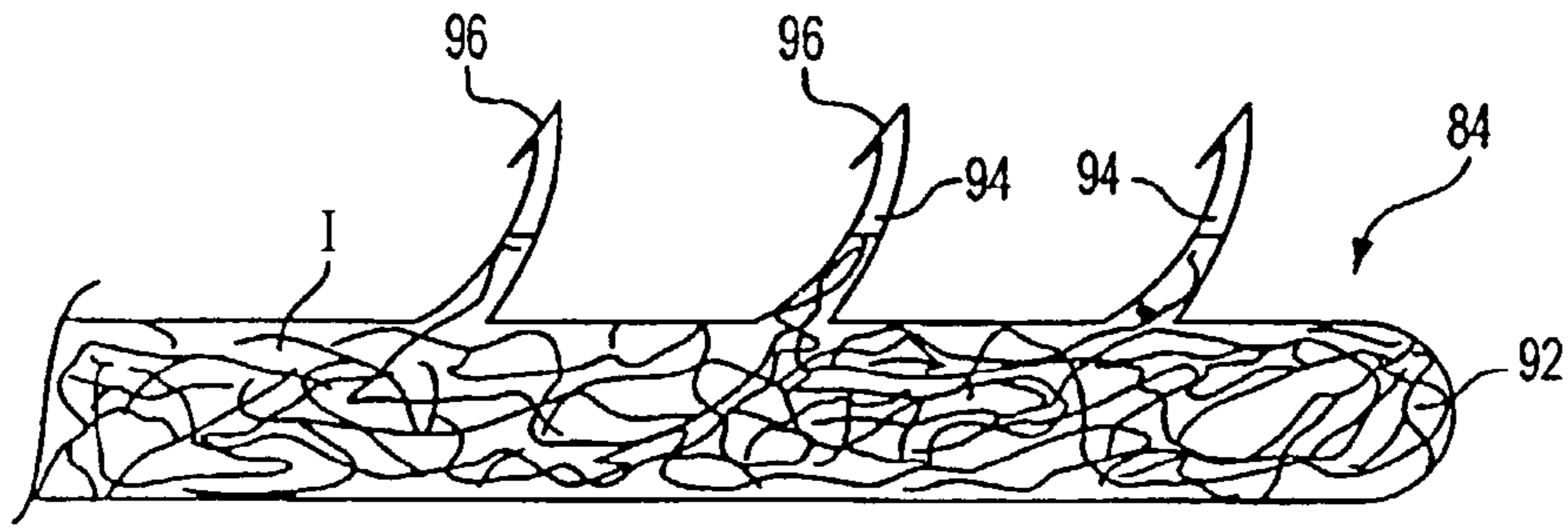

FIG. 7A

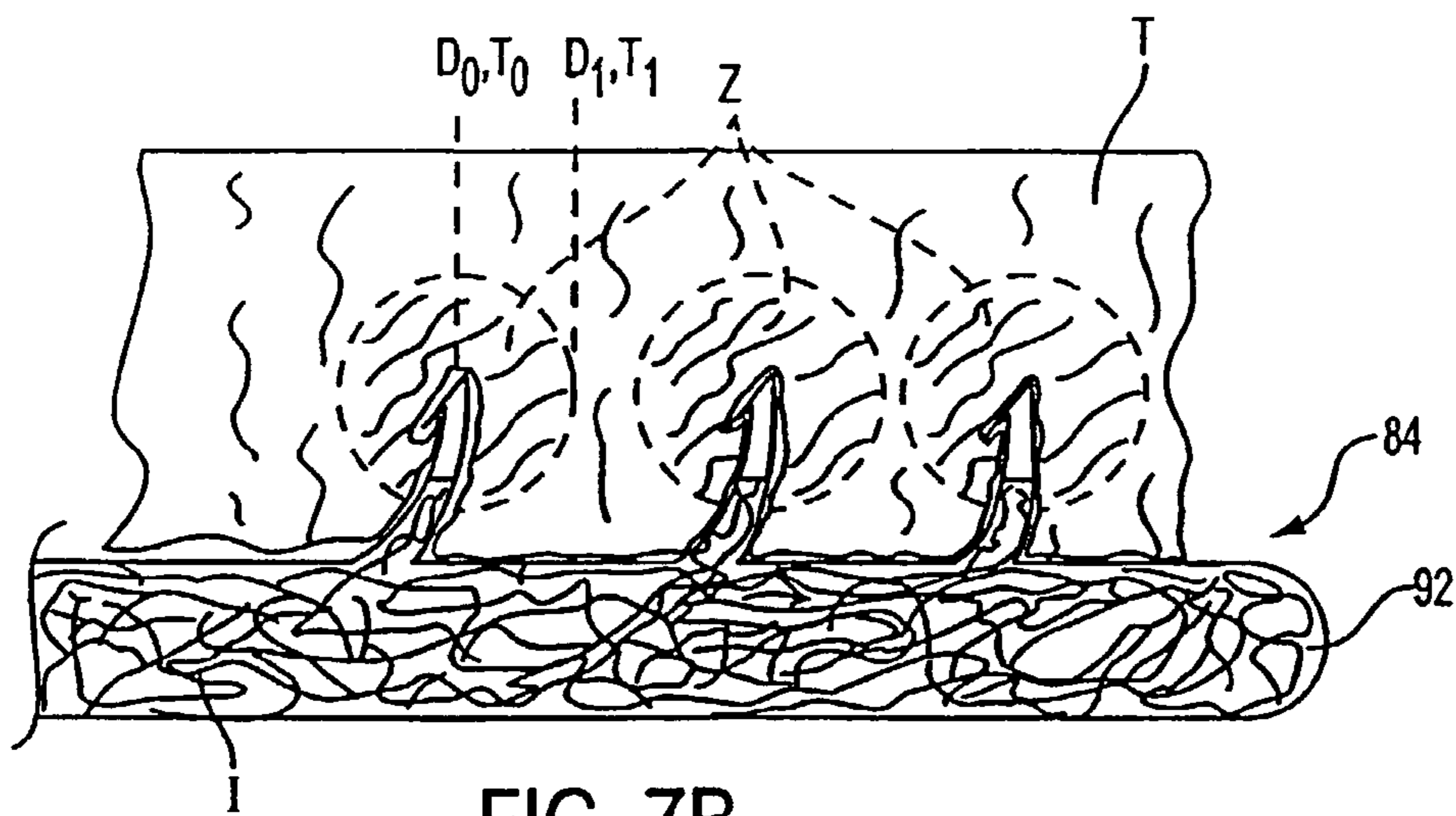

FIG. 7B

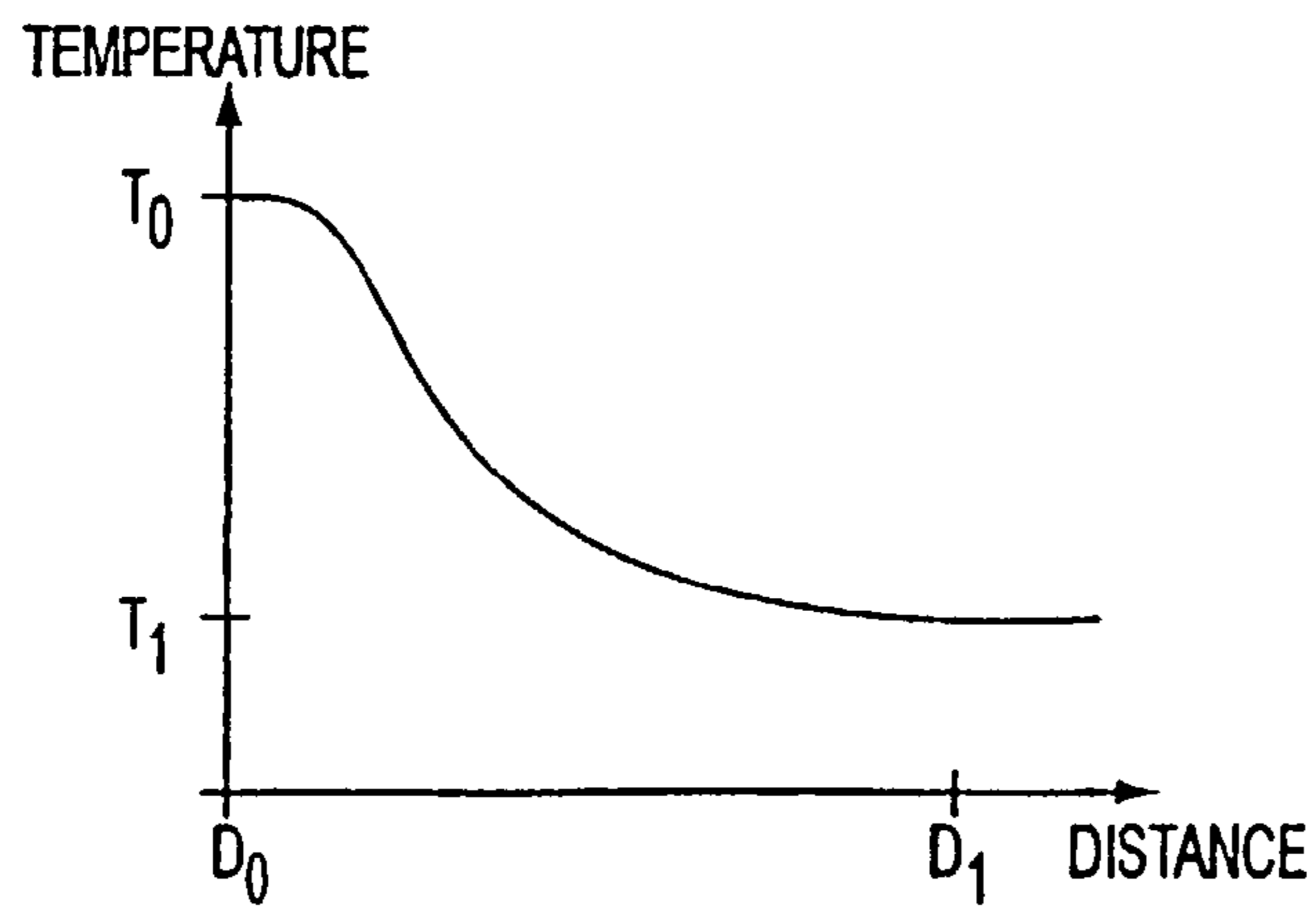

FIG. 7C

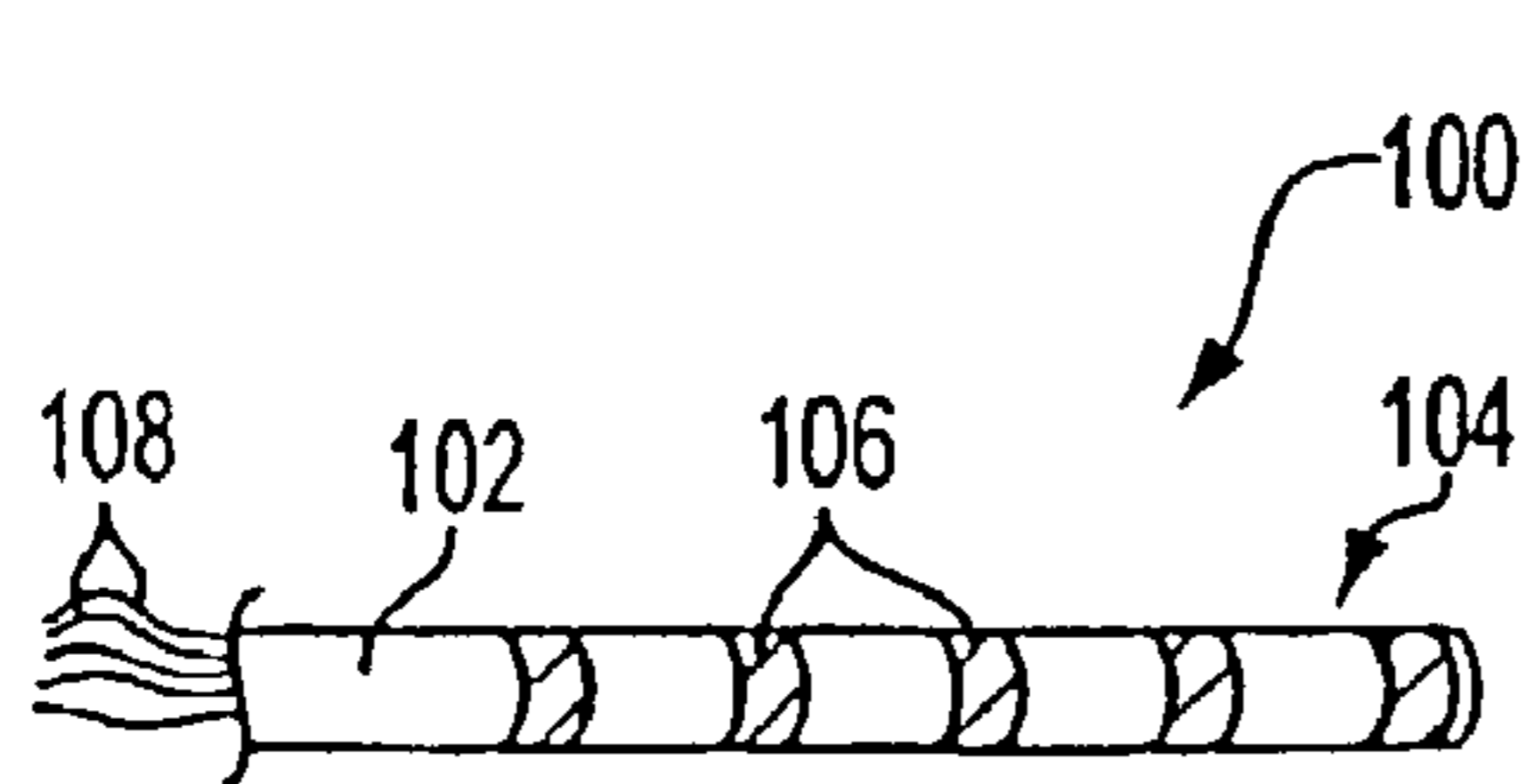

FIG. 8A

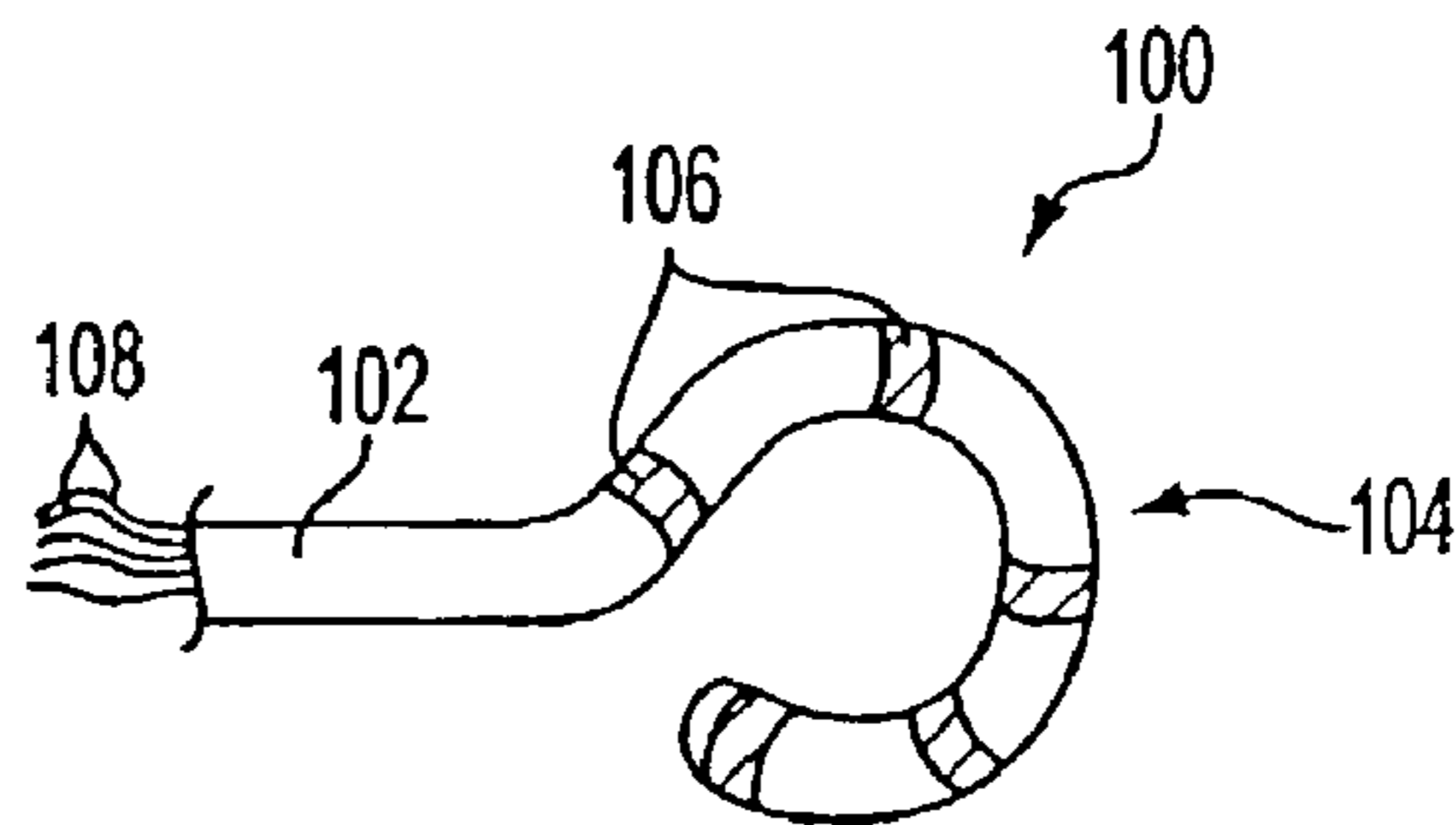

FIG. 8B

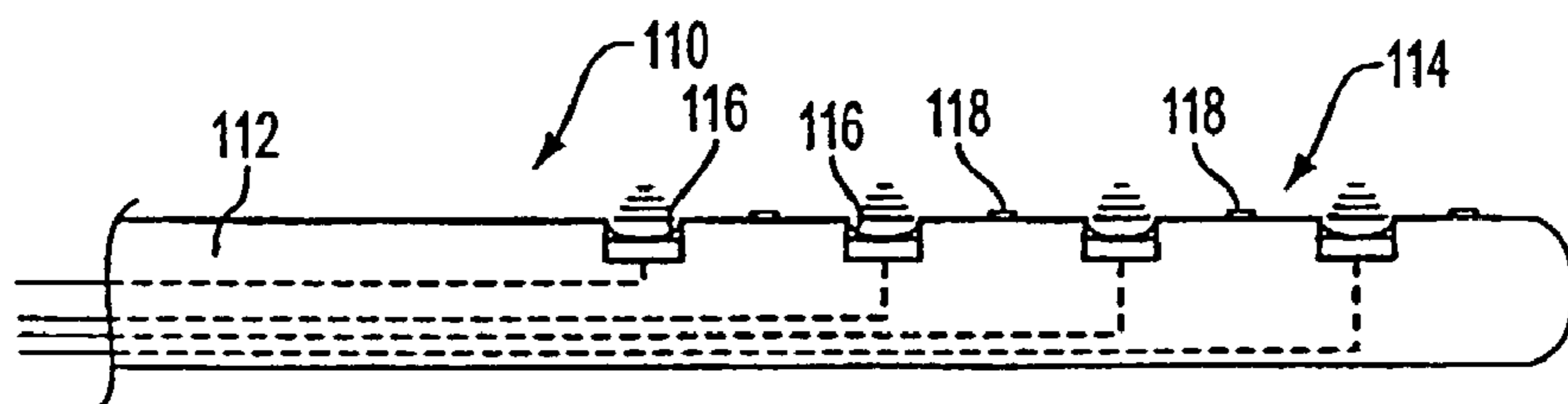

FIG. 9

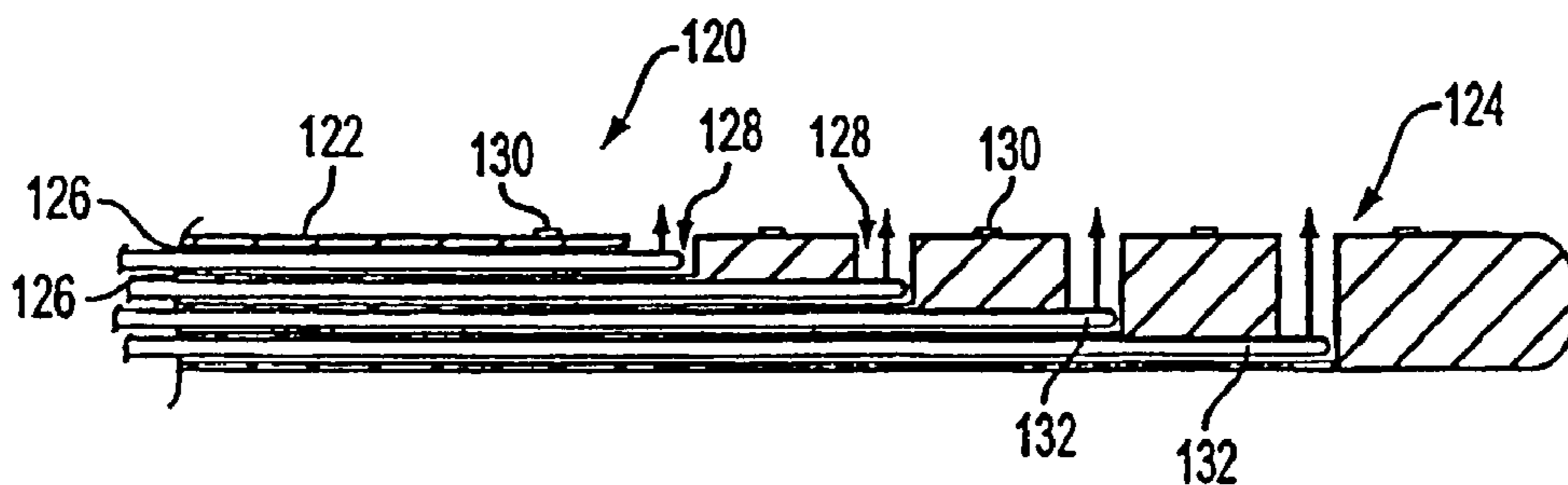

FIG. 10

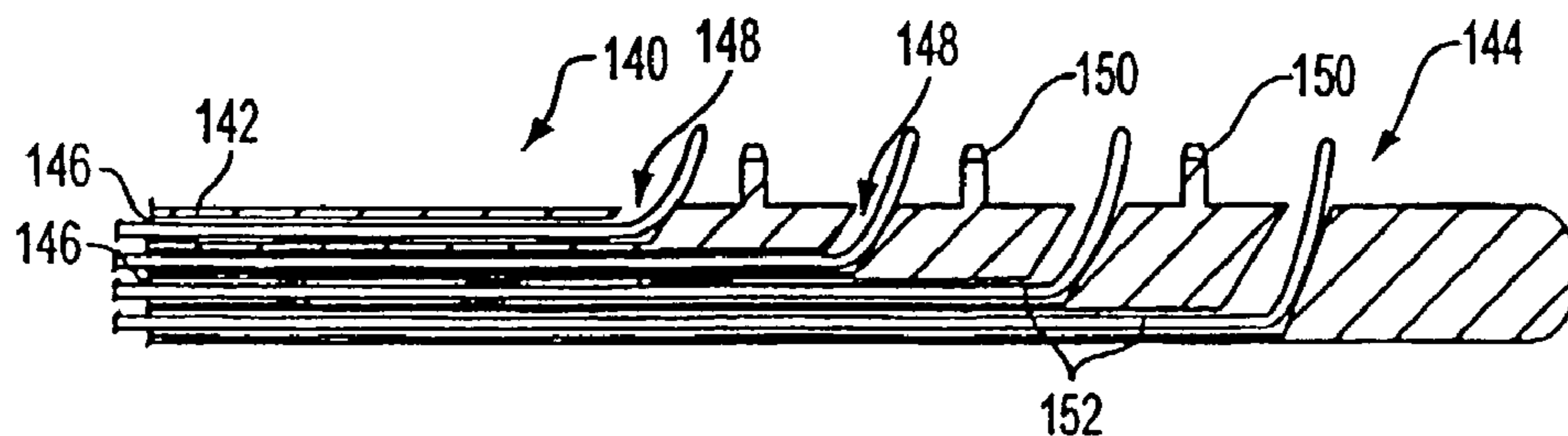

FIG. 11

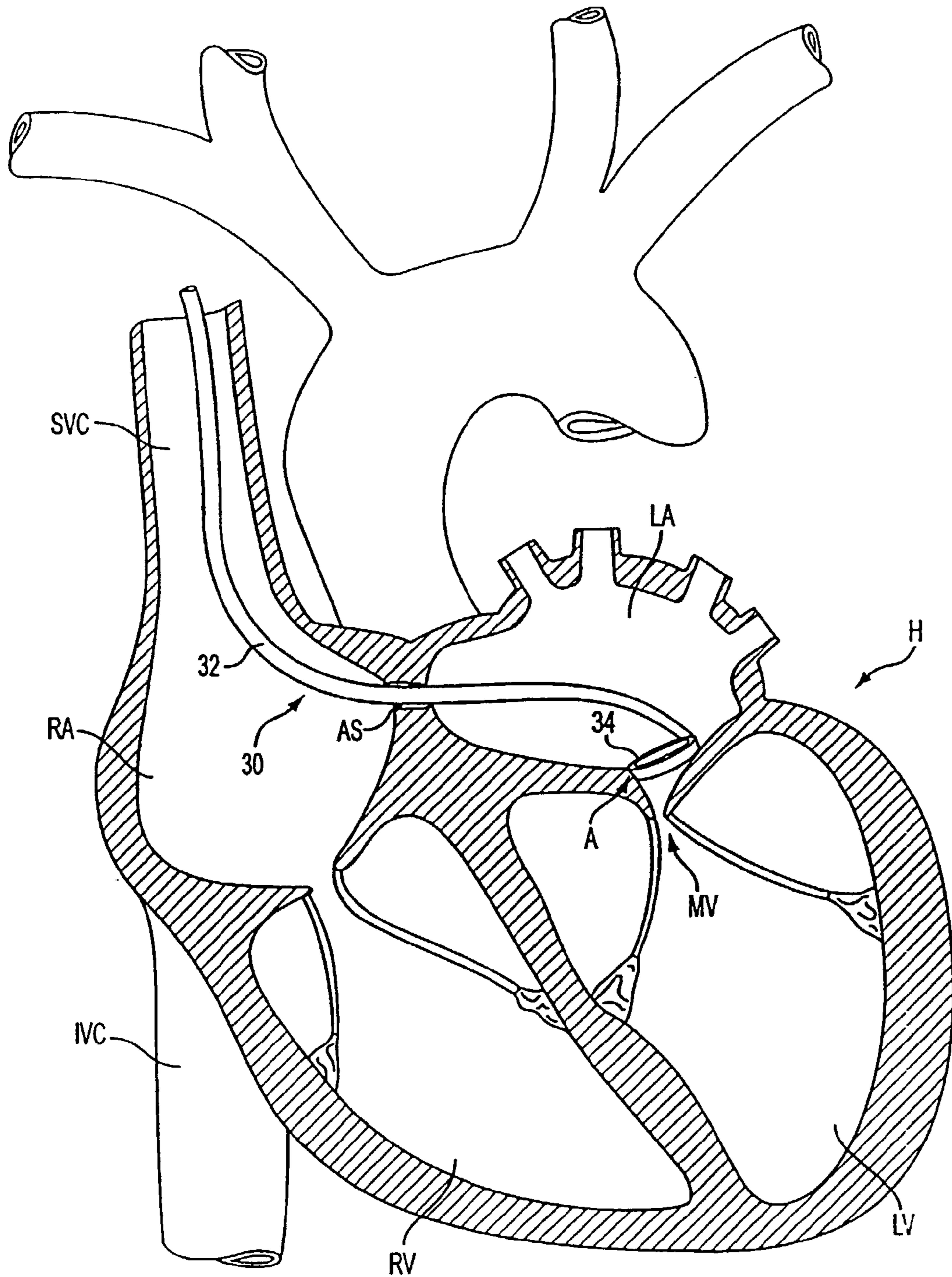

FIG. 12

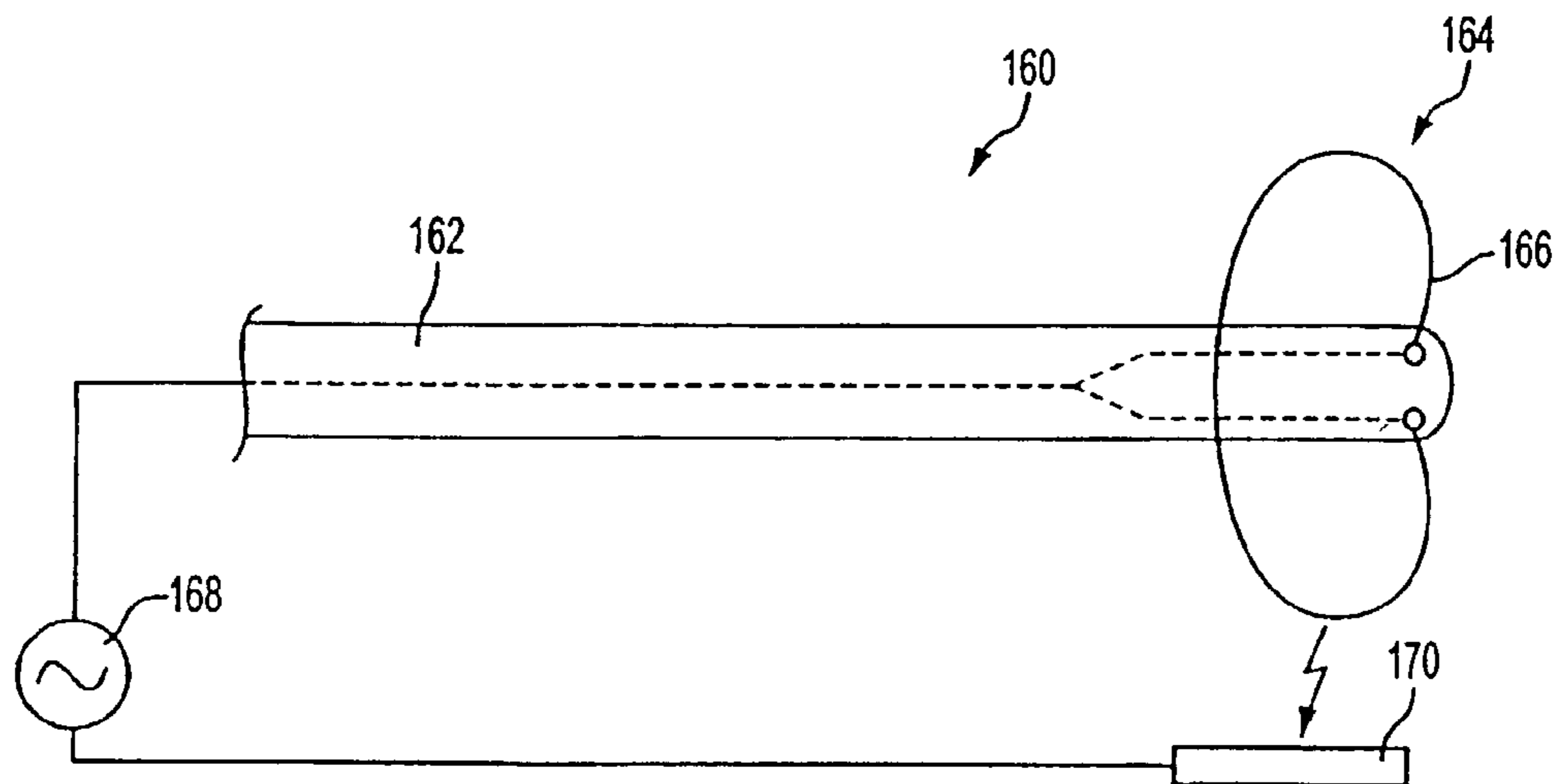

FIG. 13A

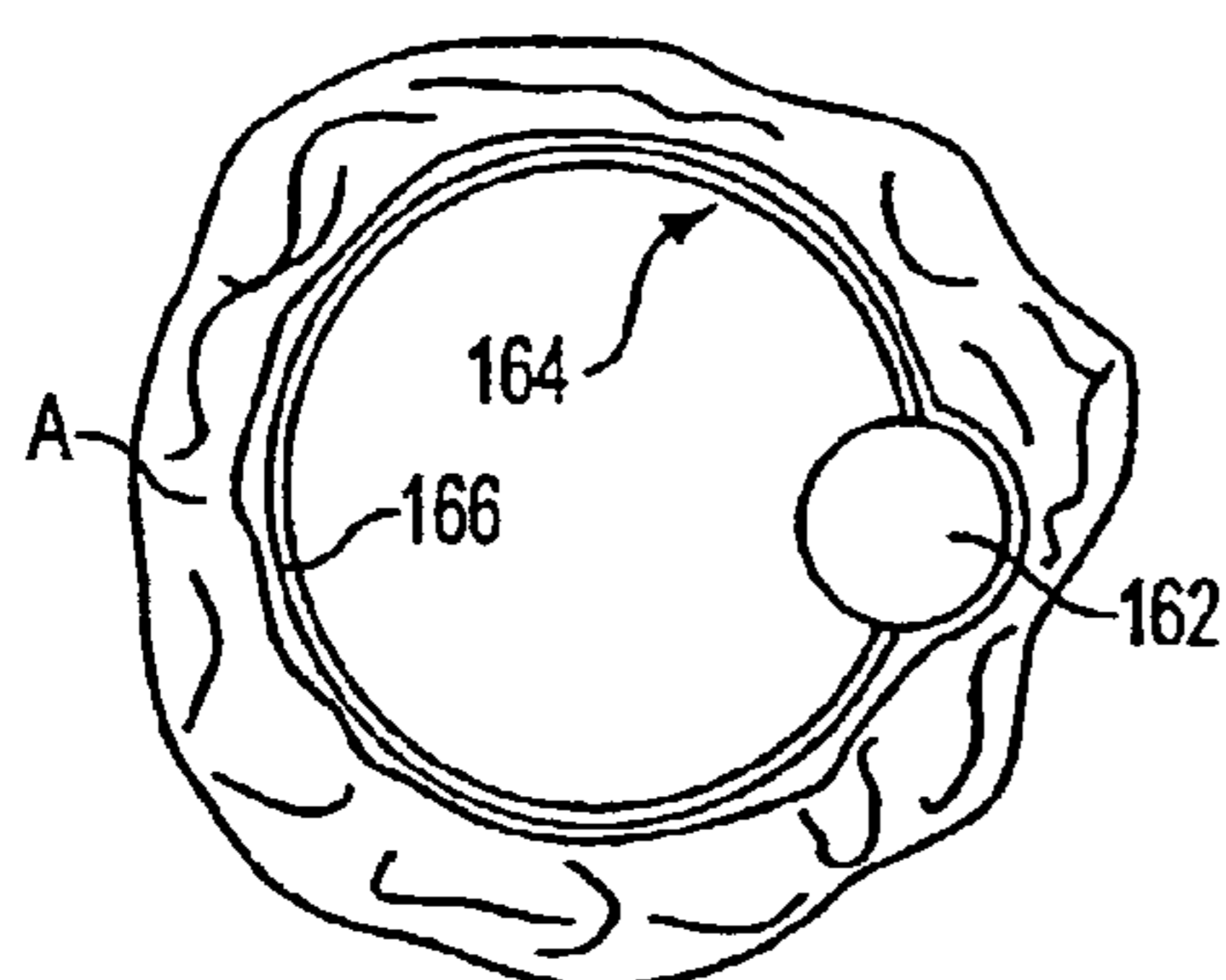

FIG. 13B

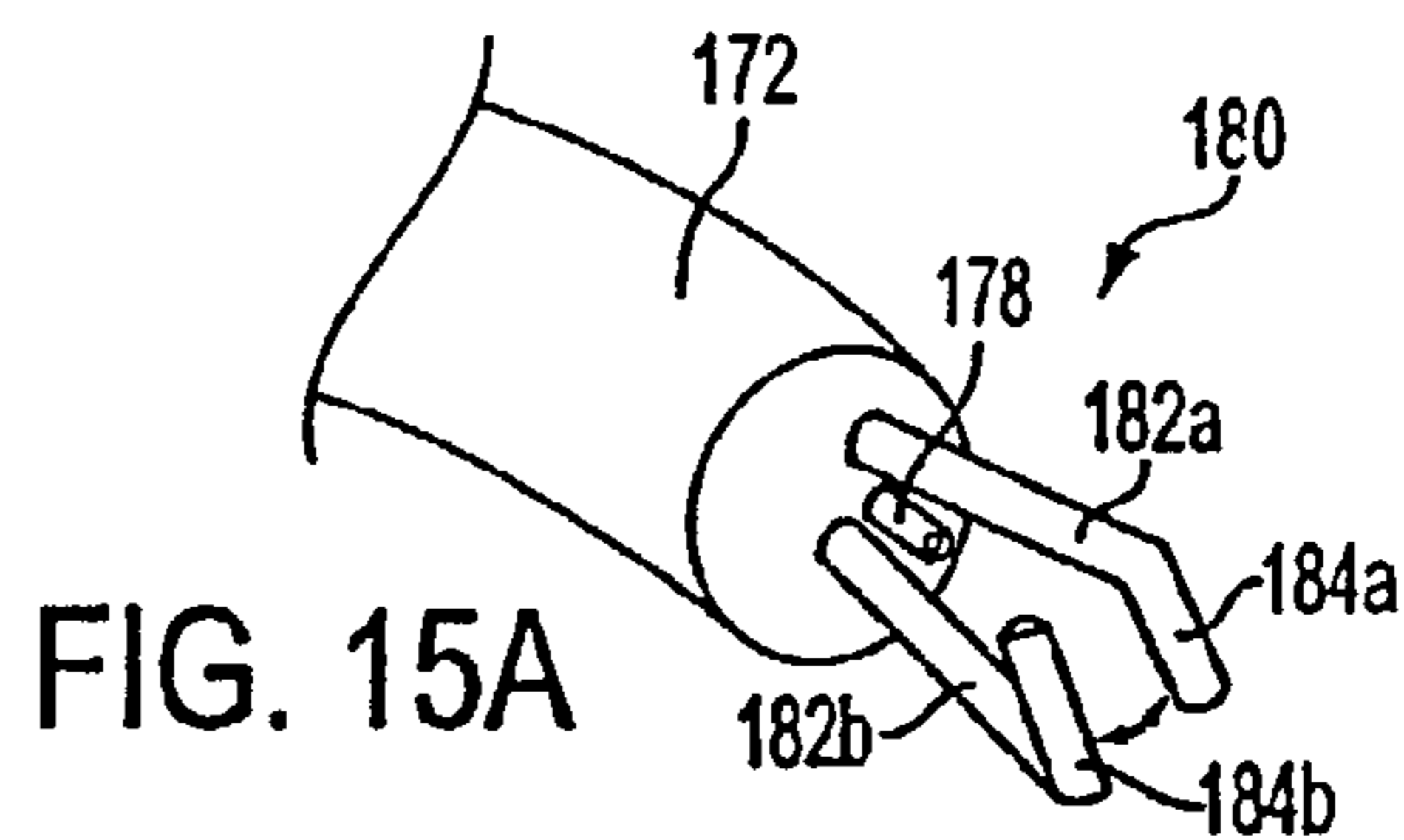

FIG. 15A

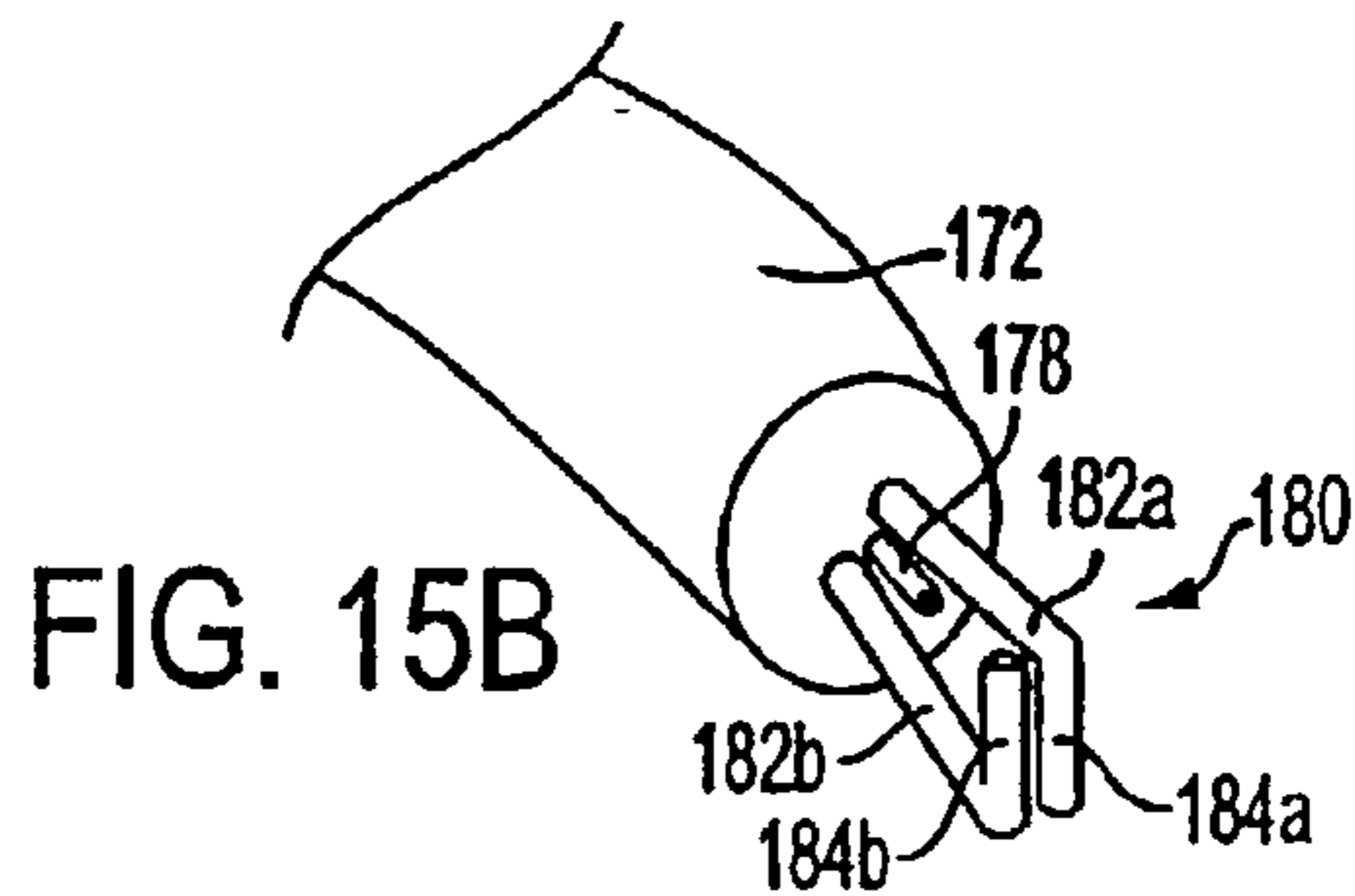

FIG. 15B

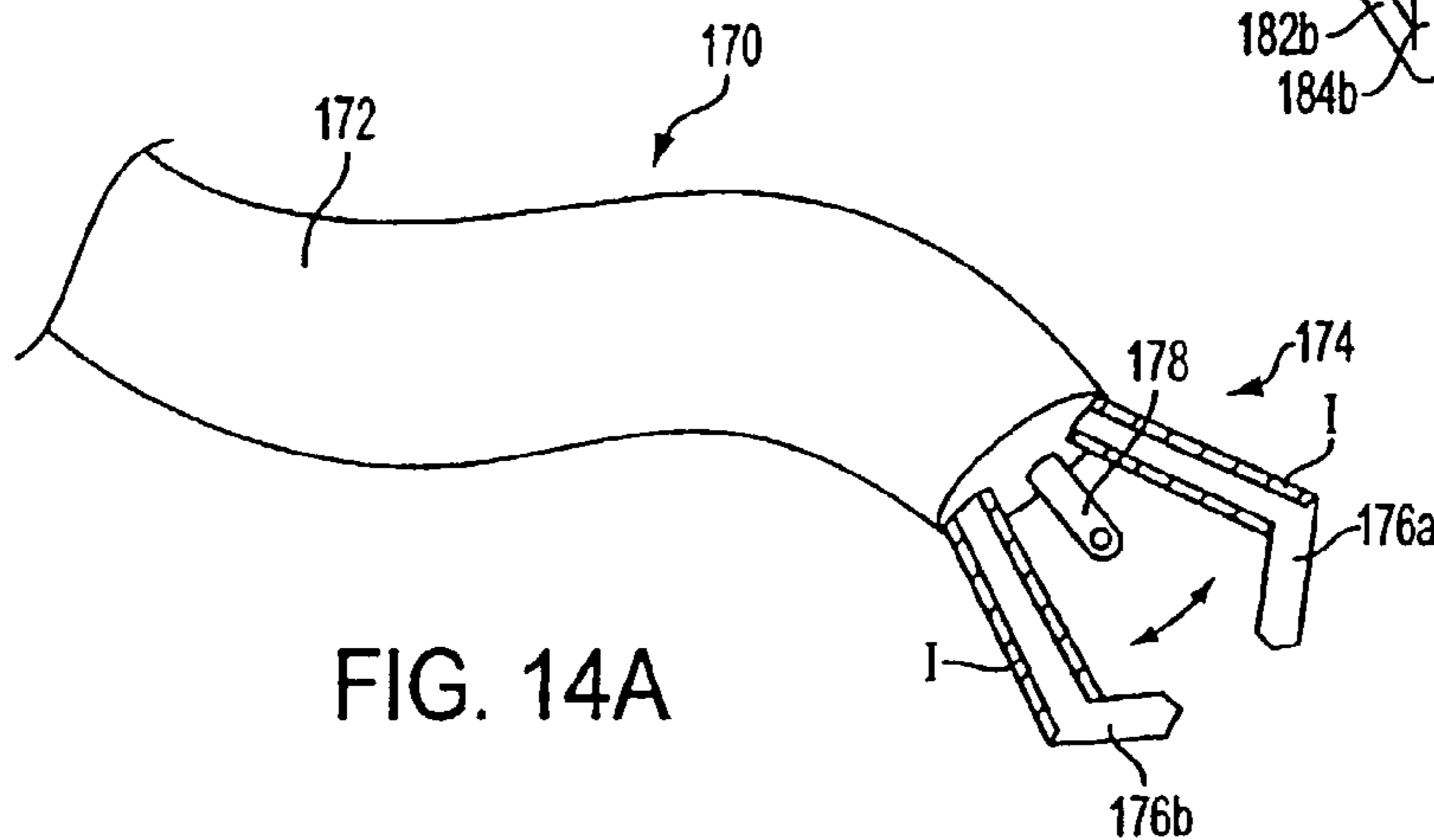

FIG. 14A

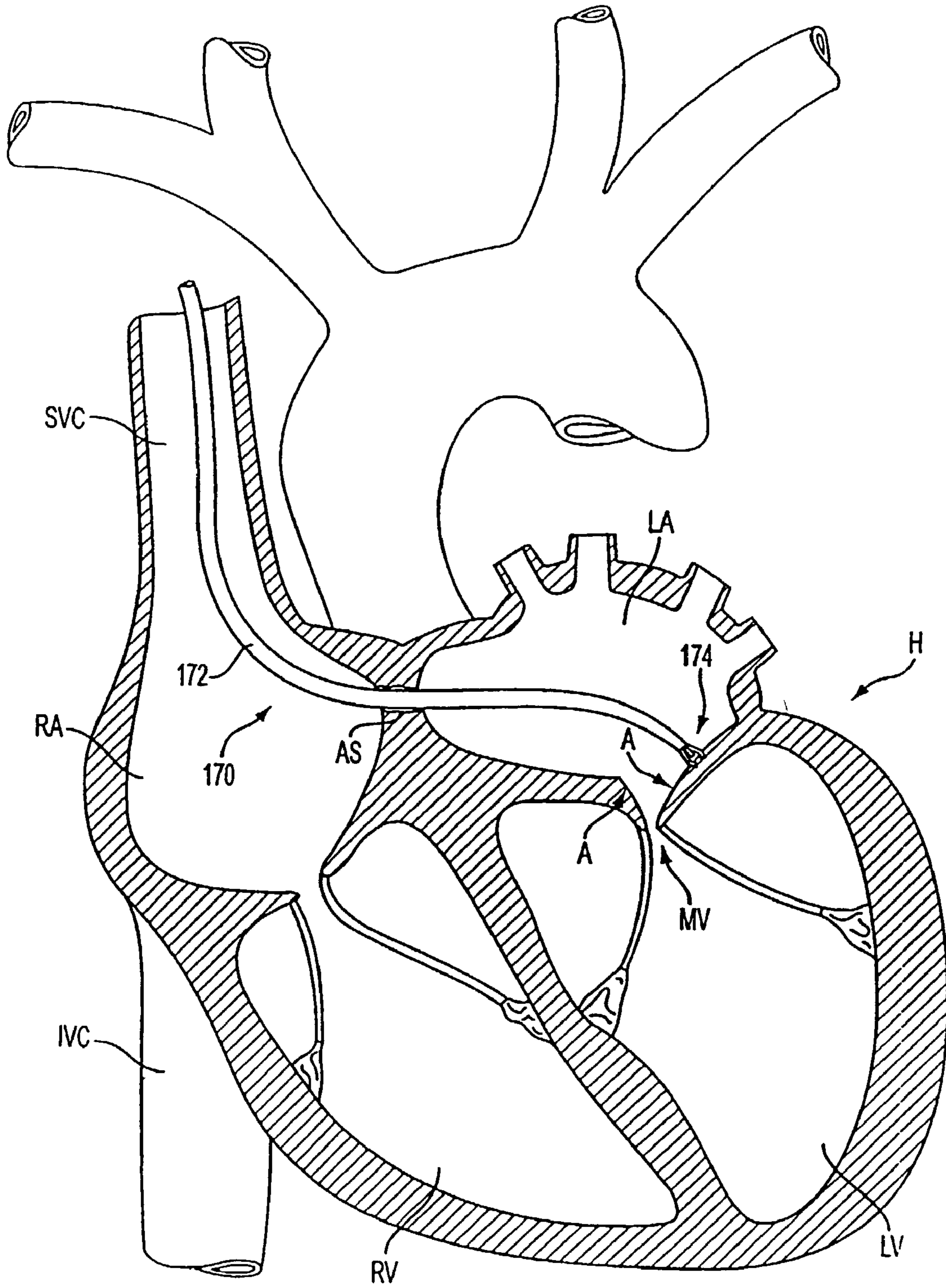

FIG. 14B

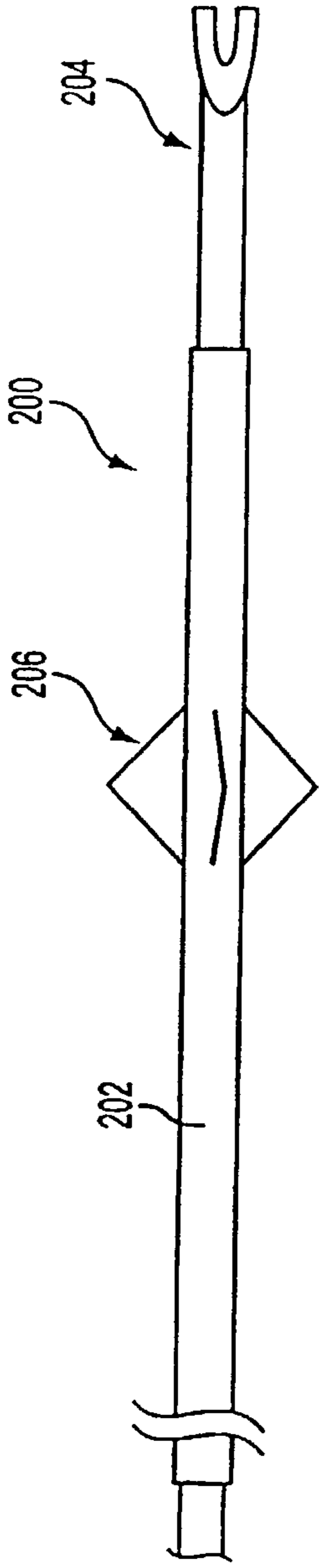

FIG. 16

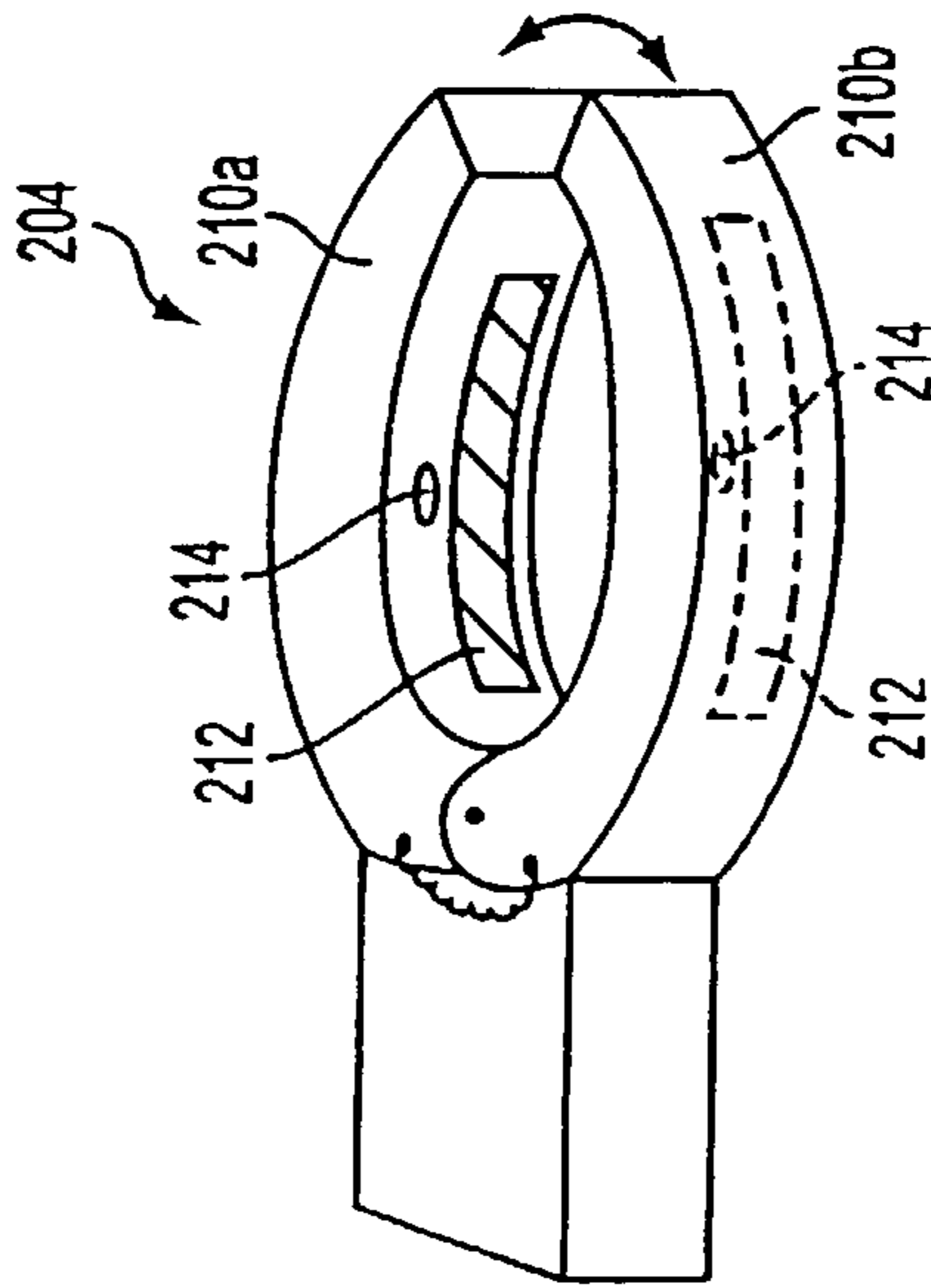

FIG. 17A

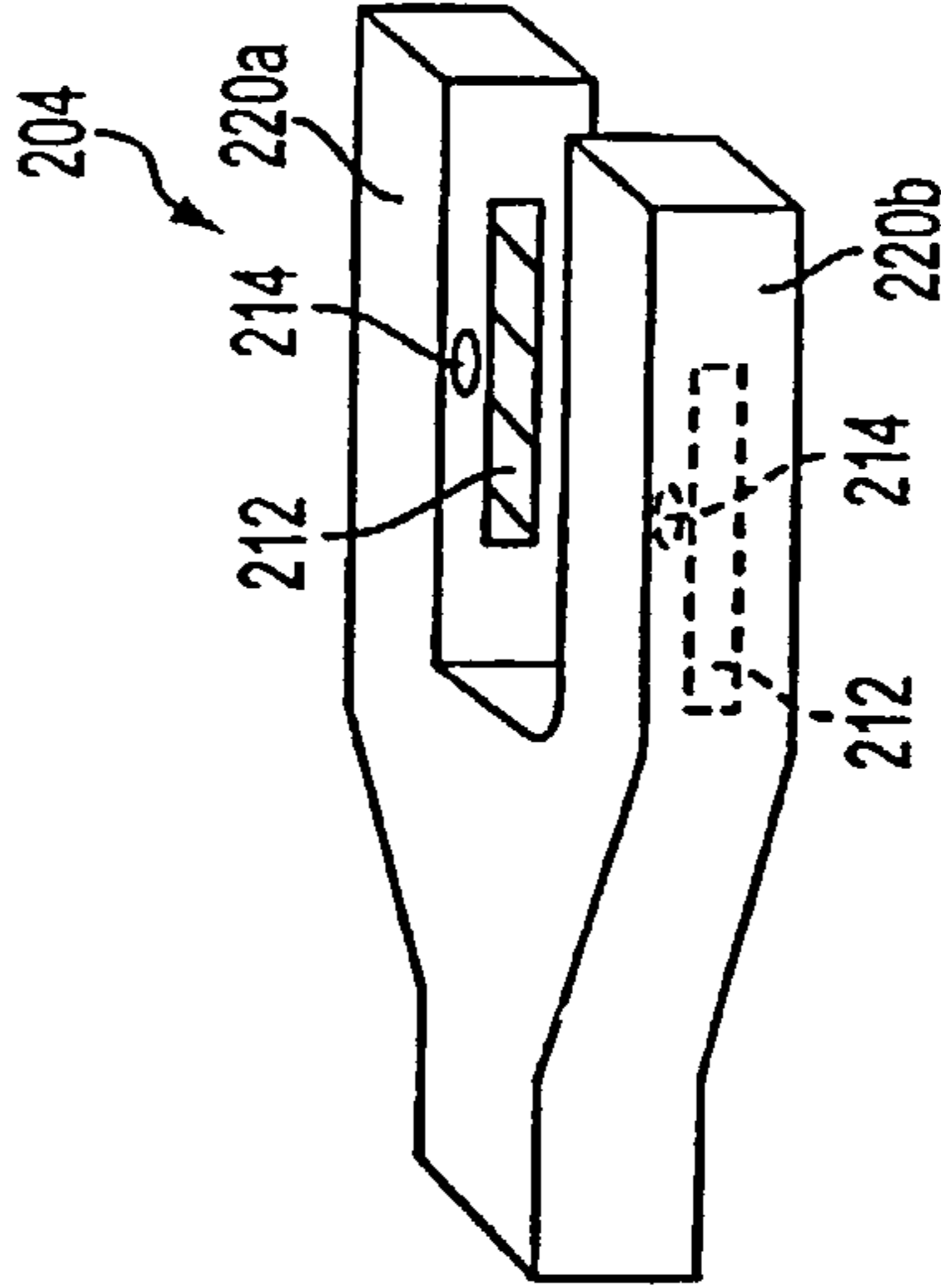

FIG. 17B

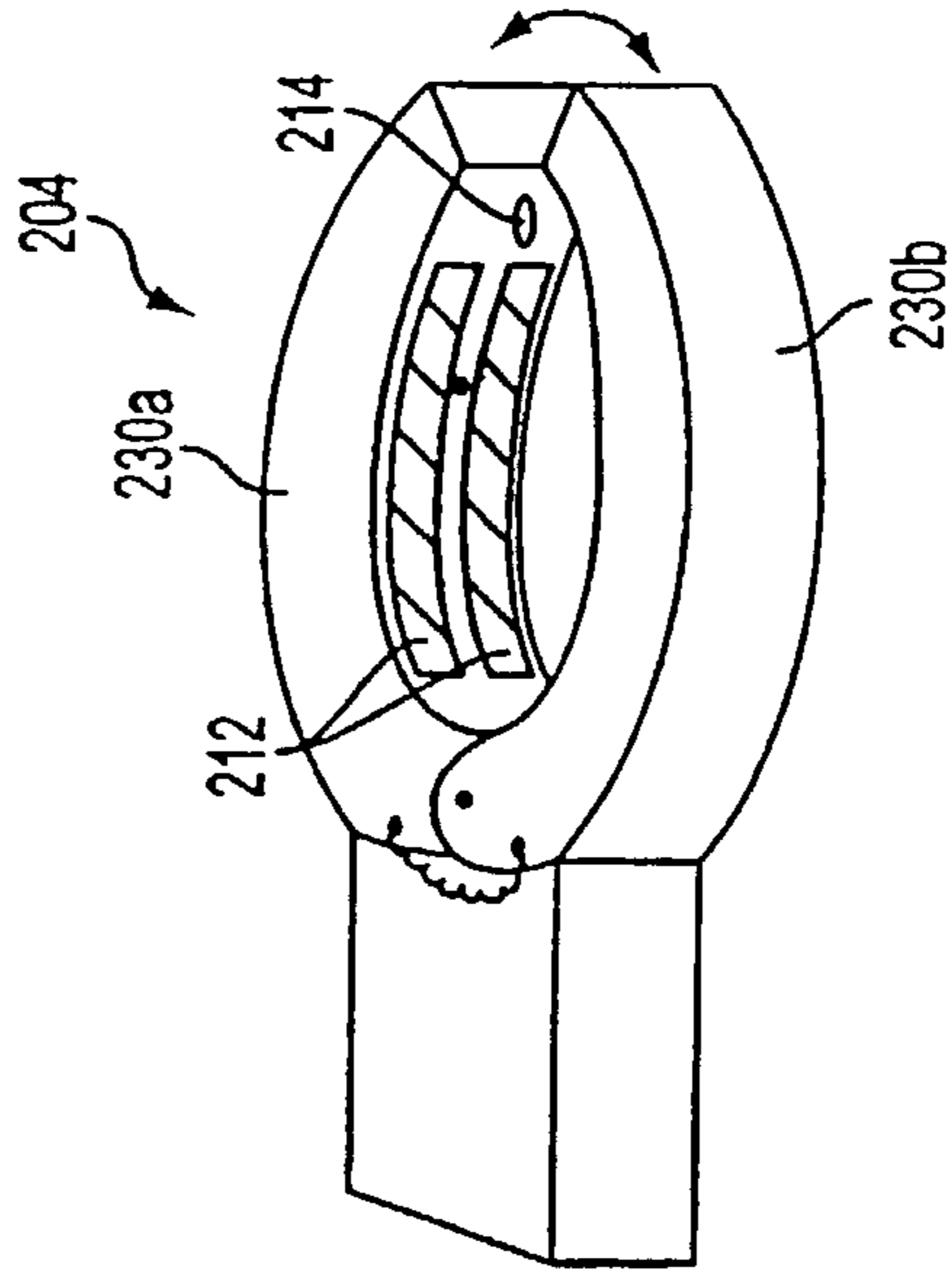

FIG. 17C

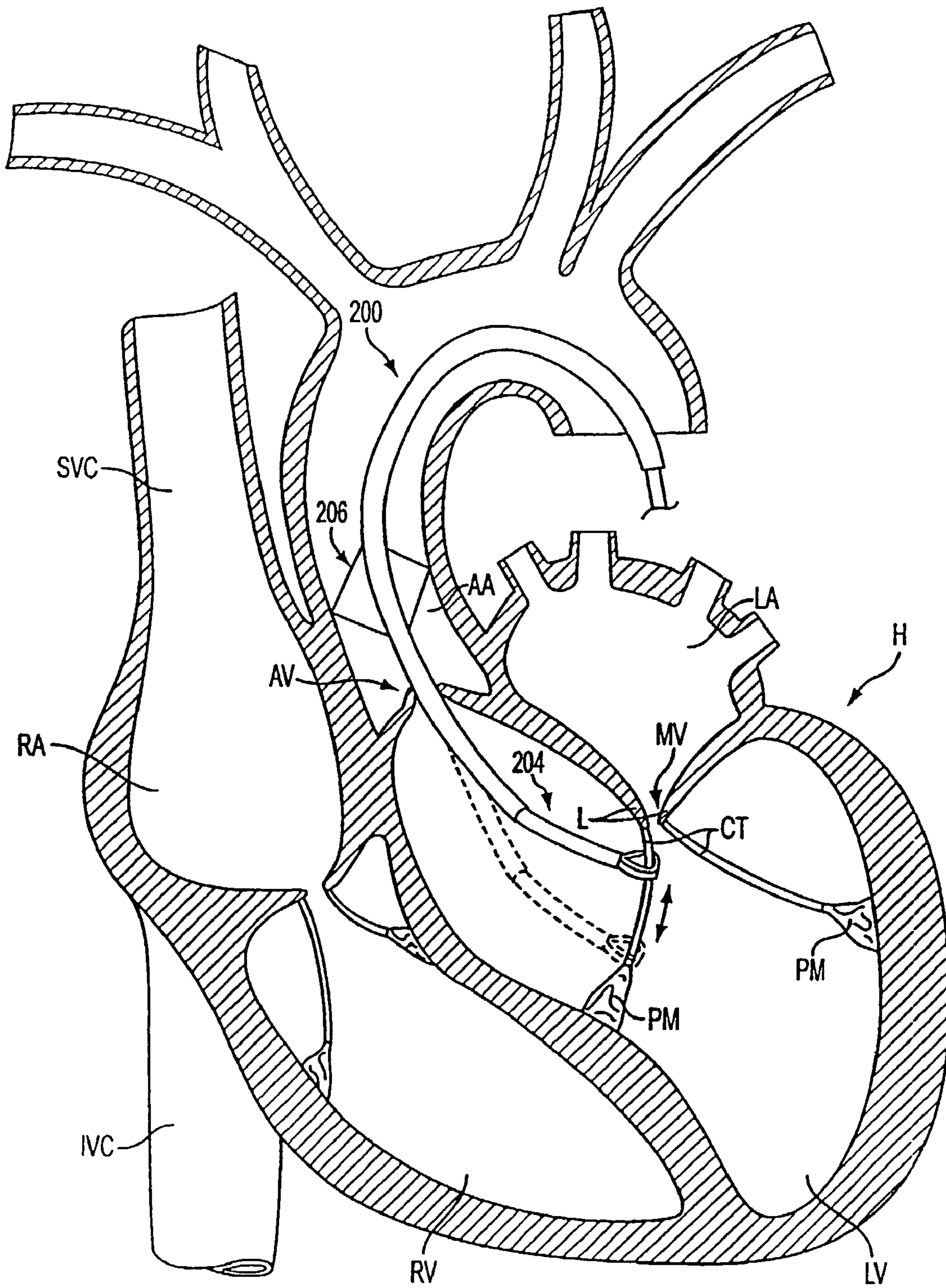

FIG. 18

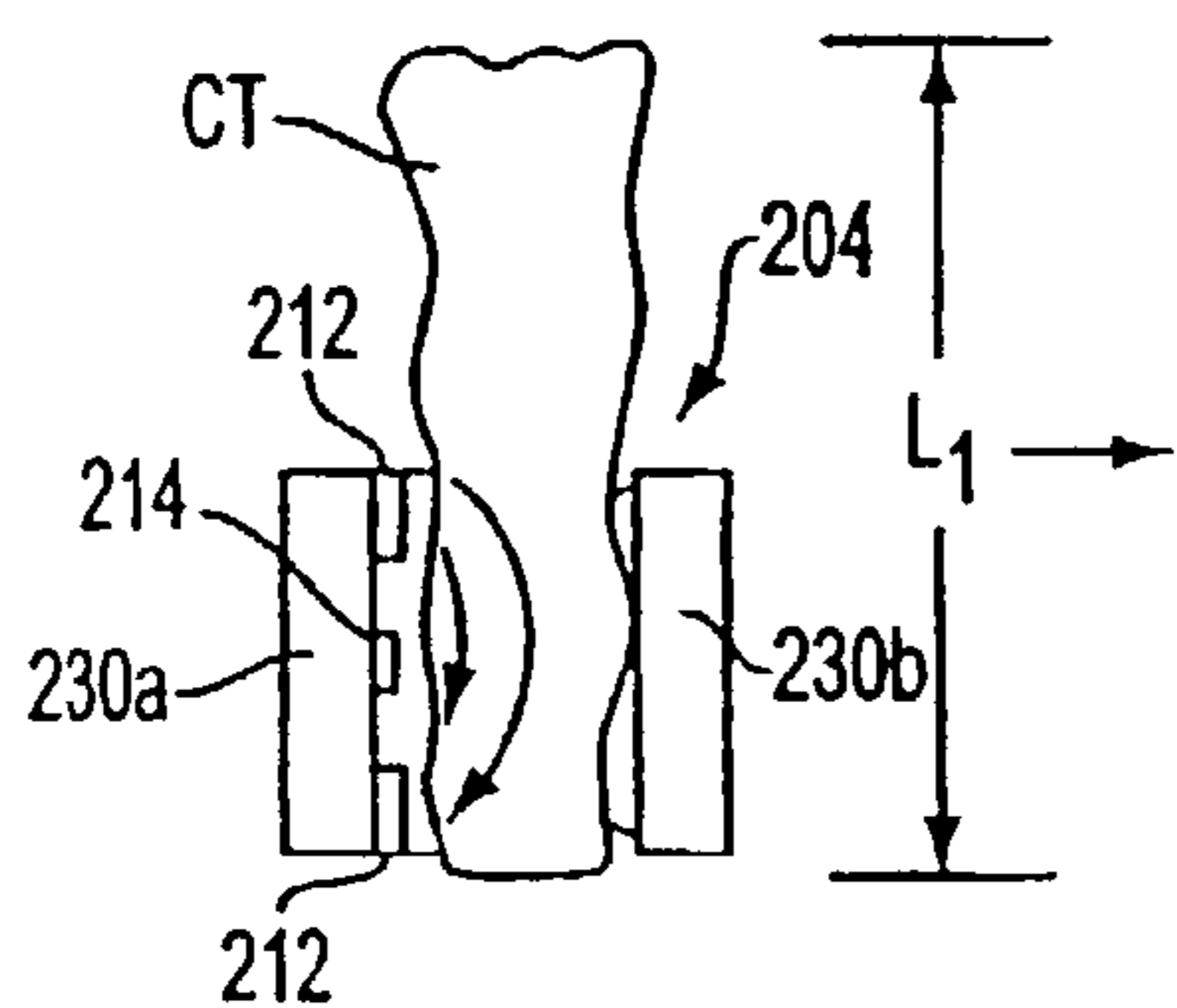

FIG. 19A

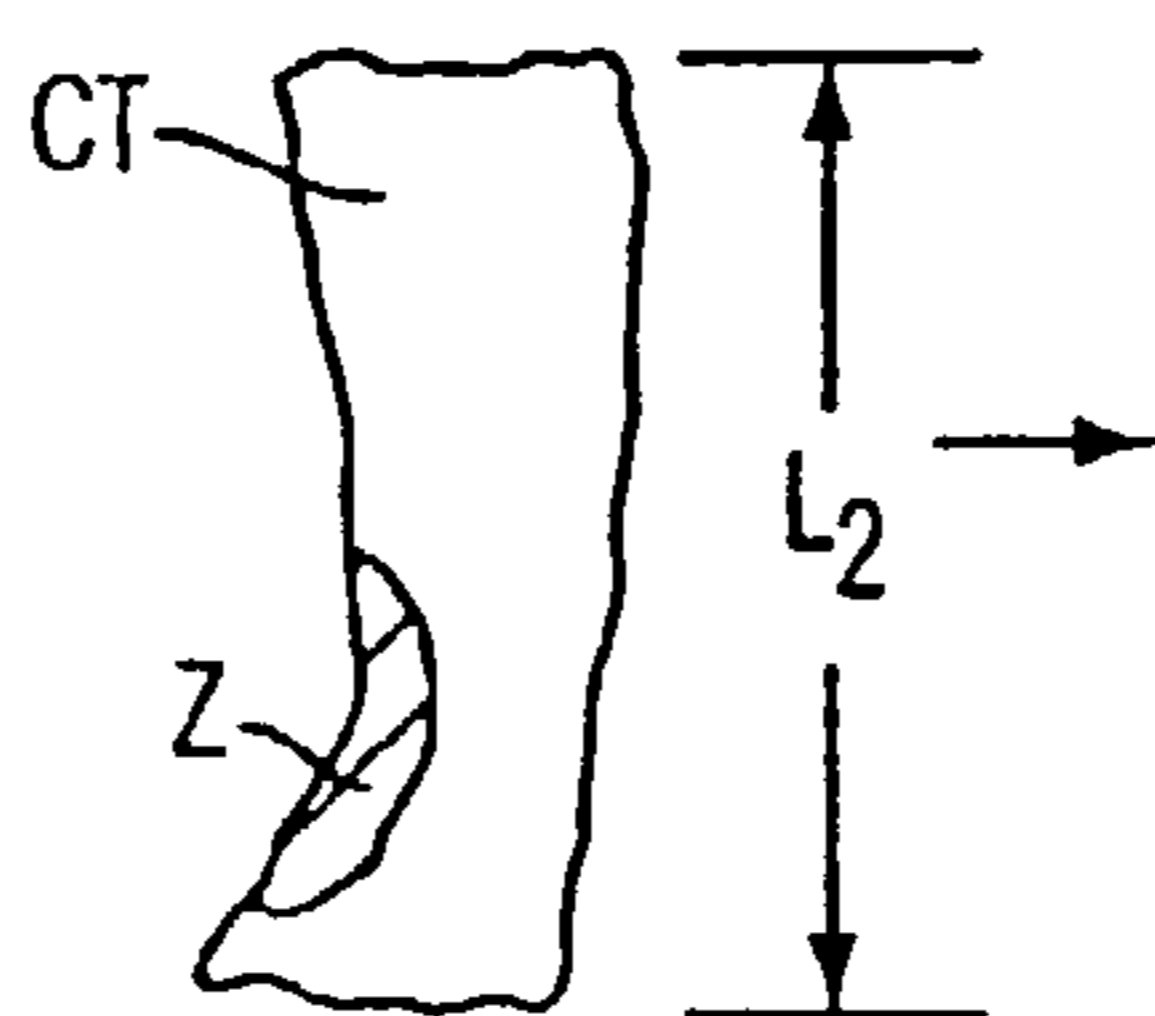

FIG. 19B

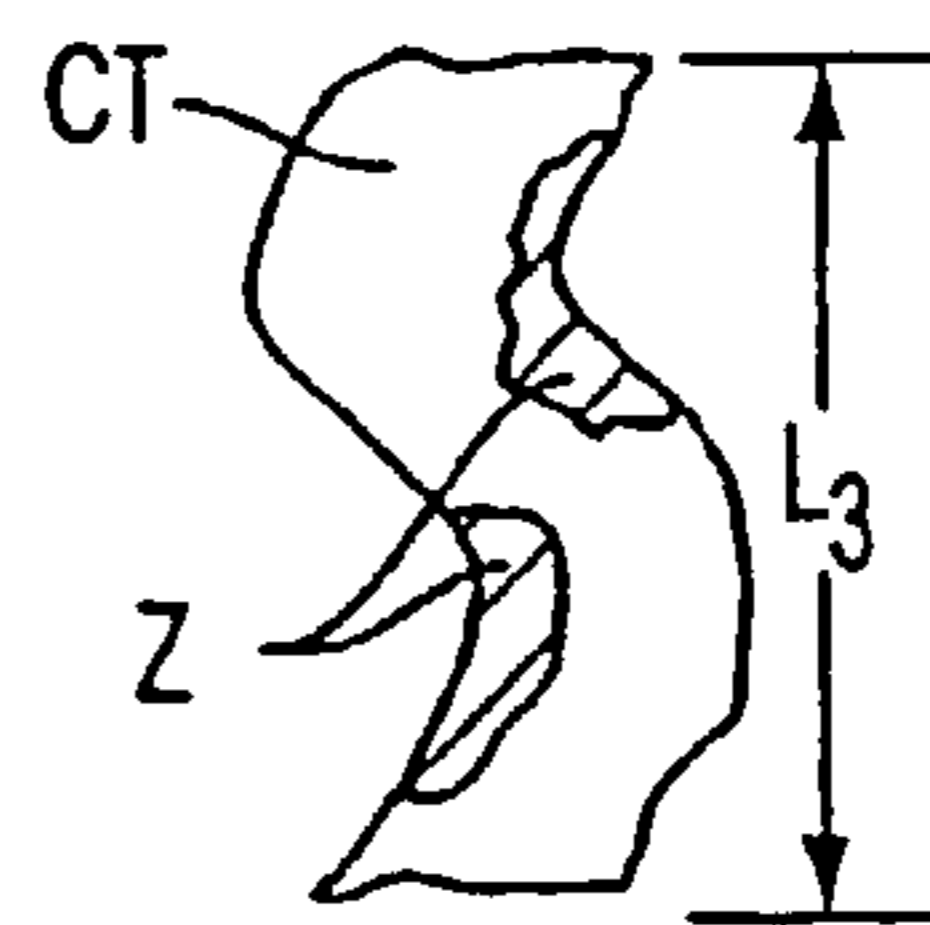

FIG. 19C

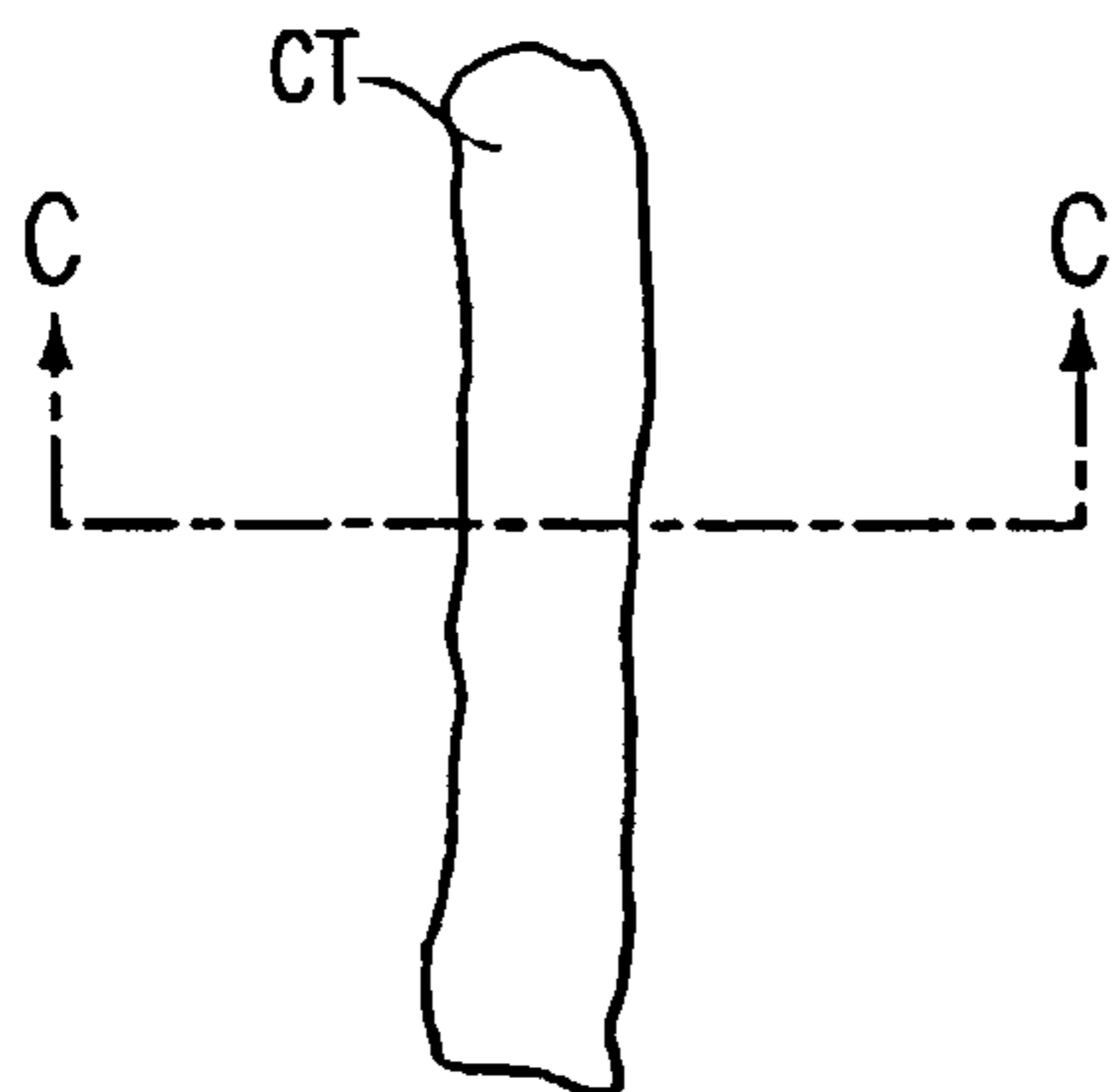

FIG. 20A

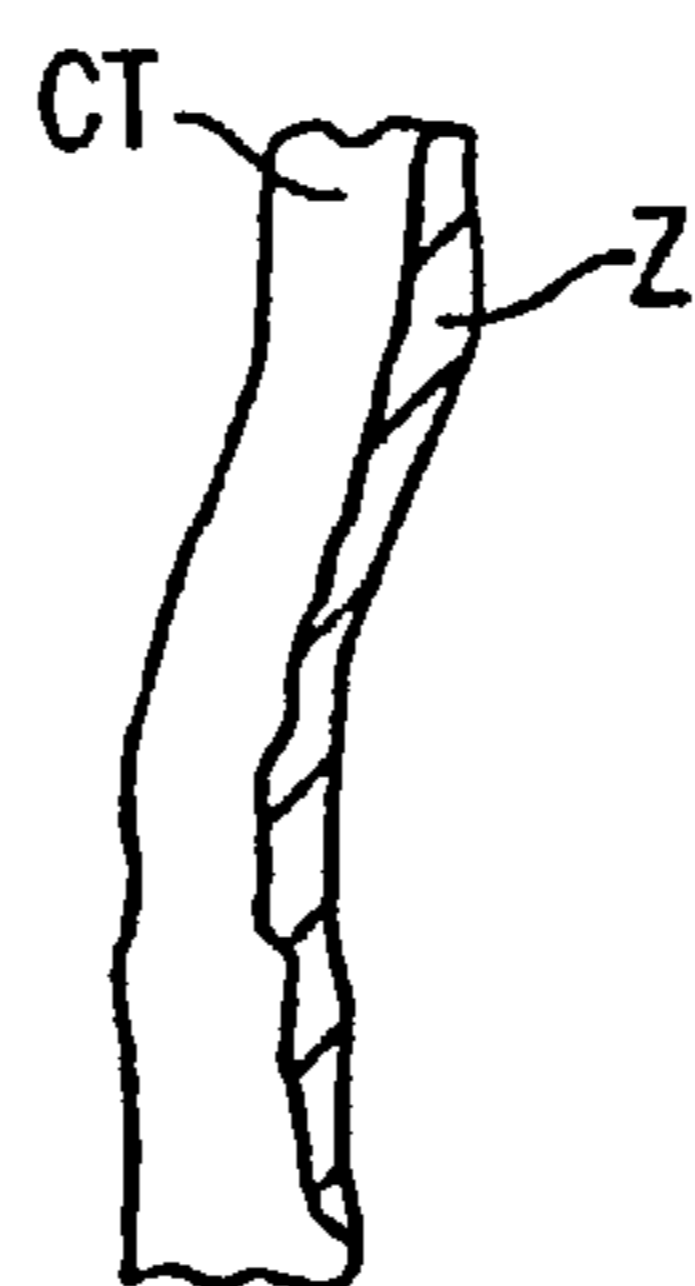

FIG. 20B

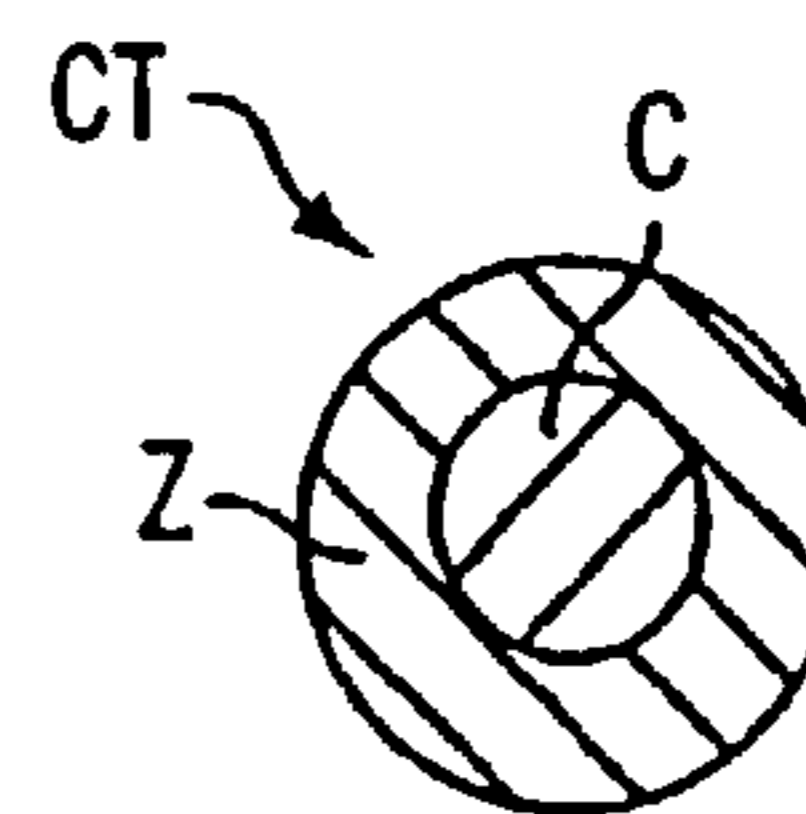

FIG. 20C

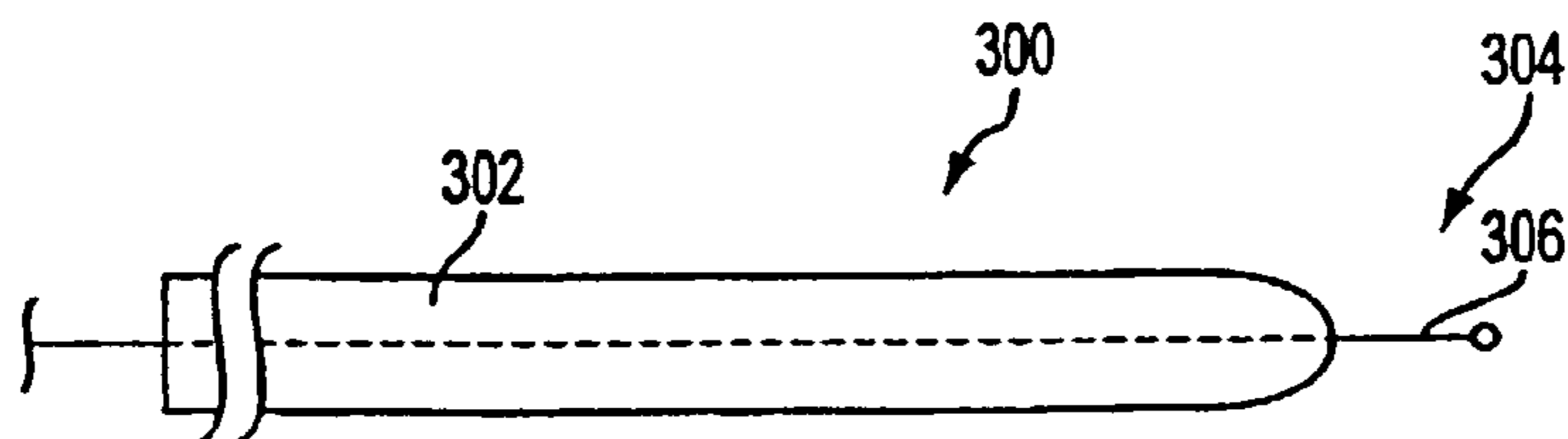

FIG. 21A

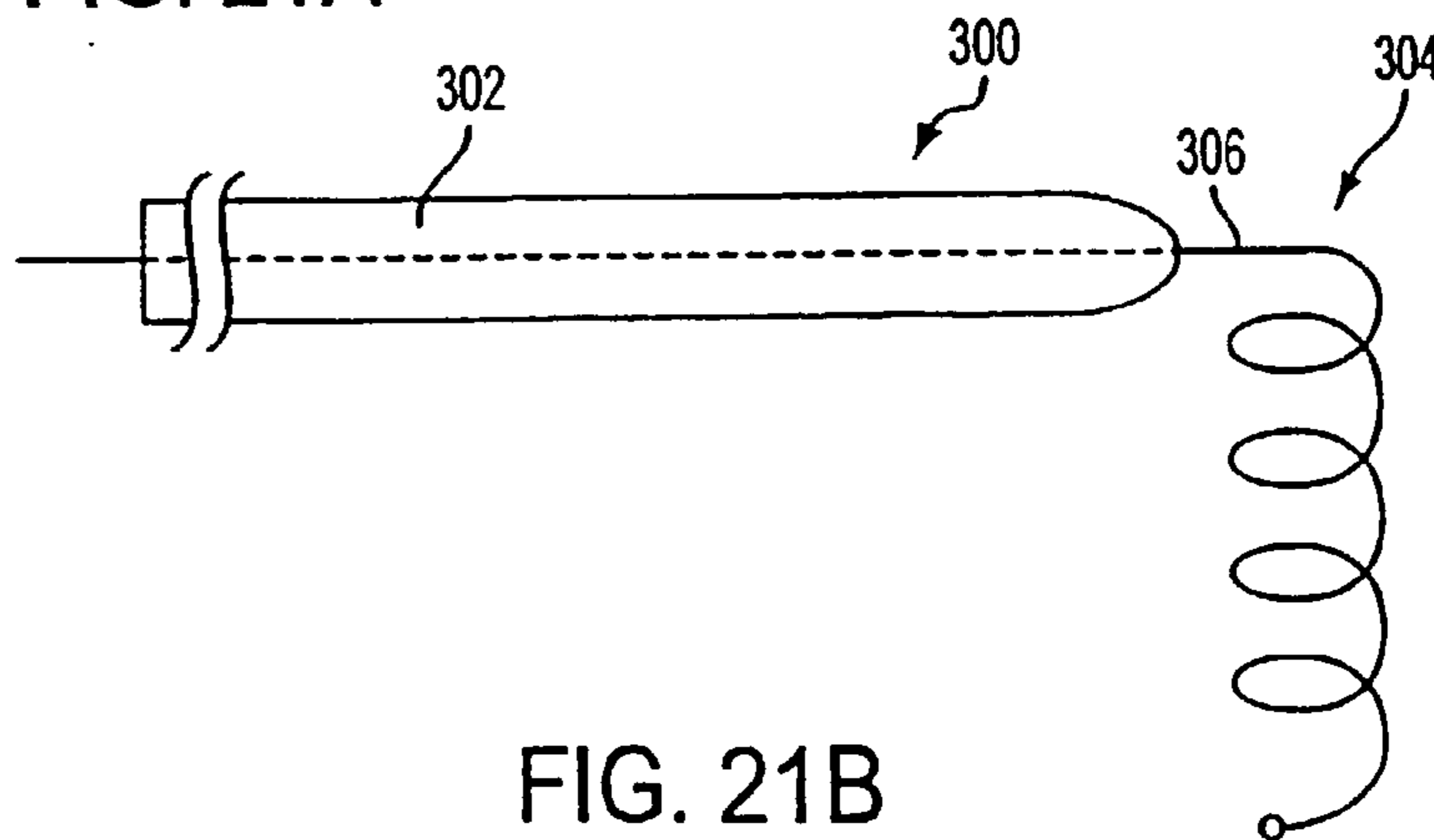

FIG. 21B

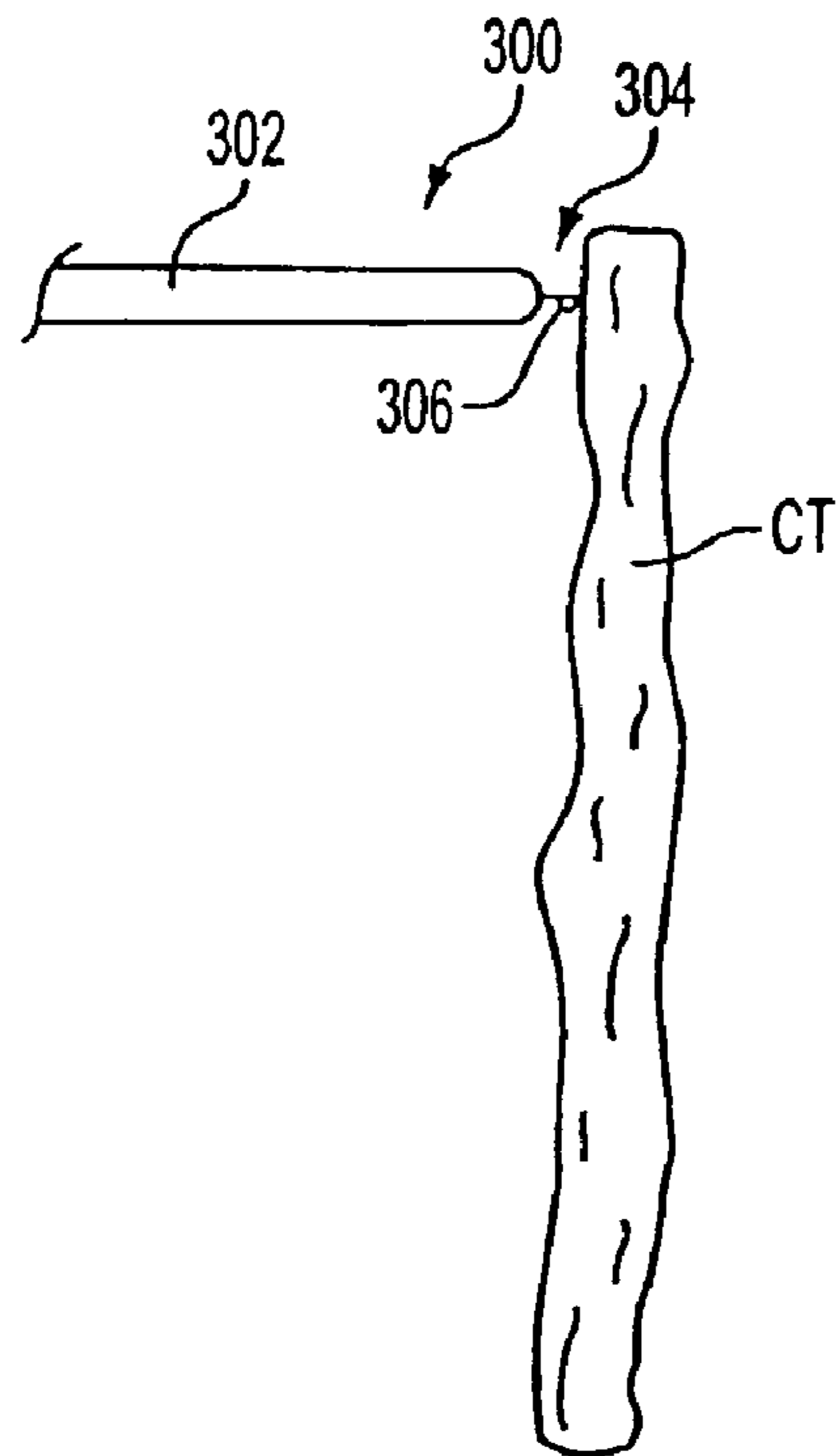

FIG. 22A

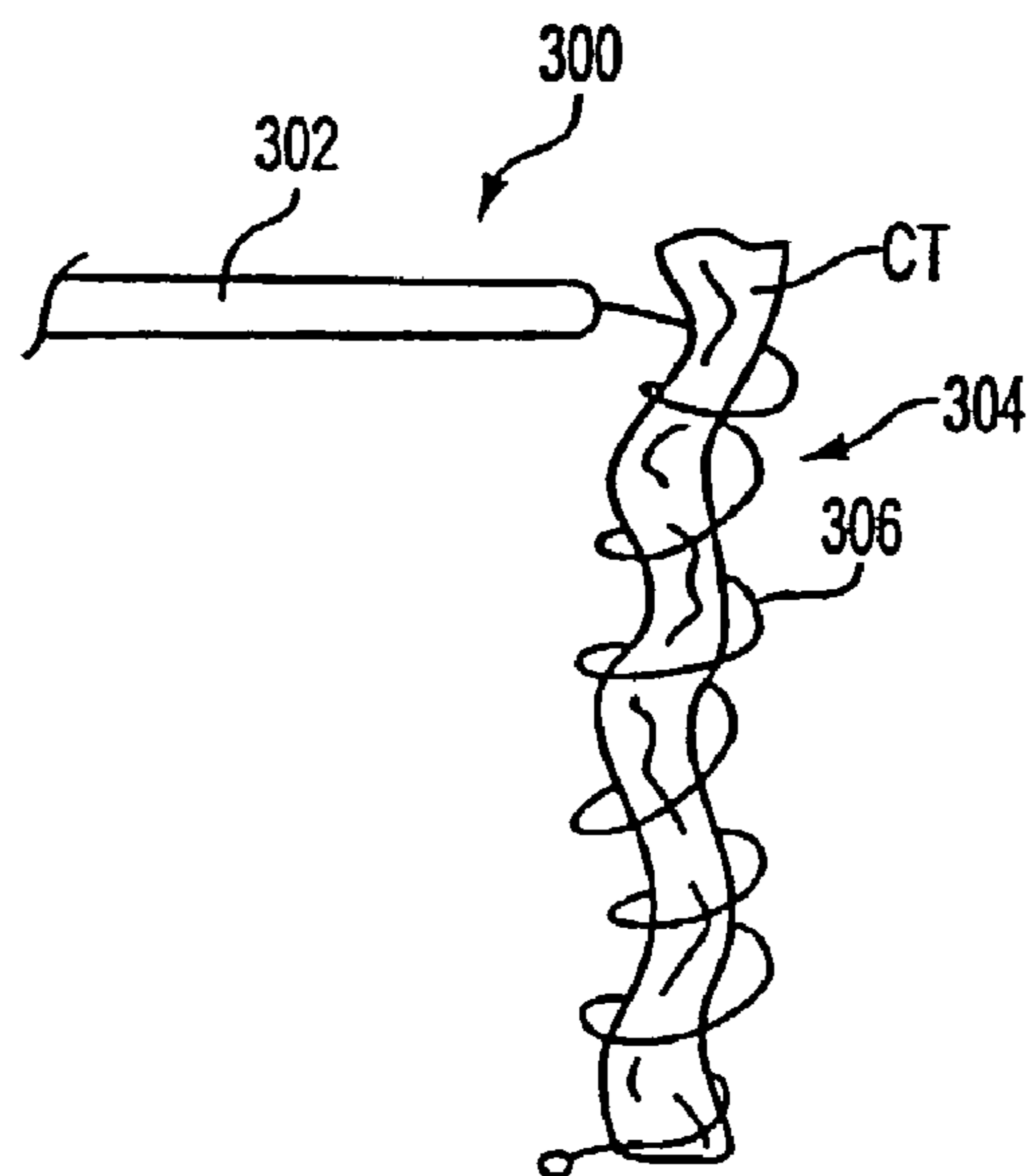

FIG. 22B

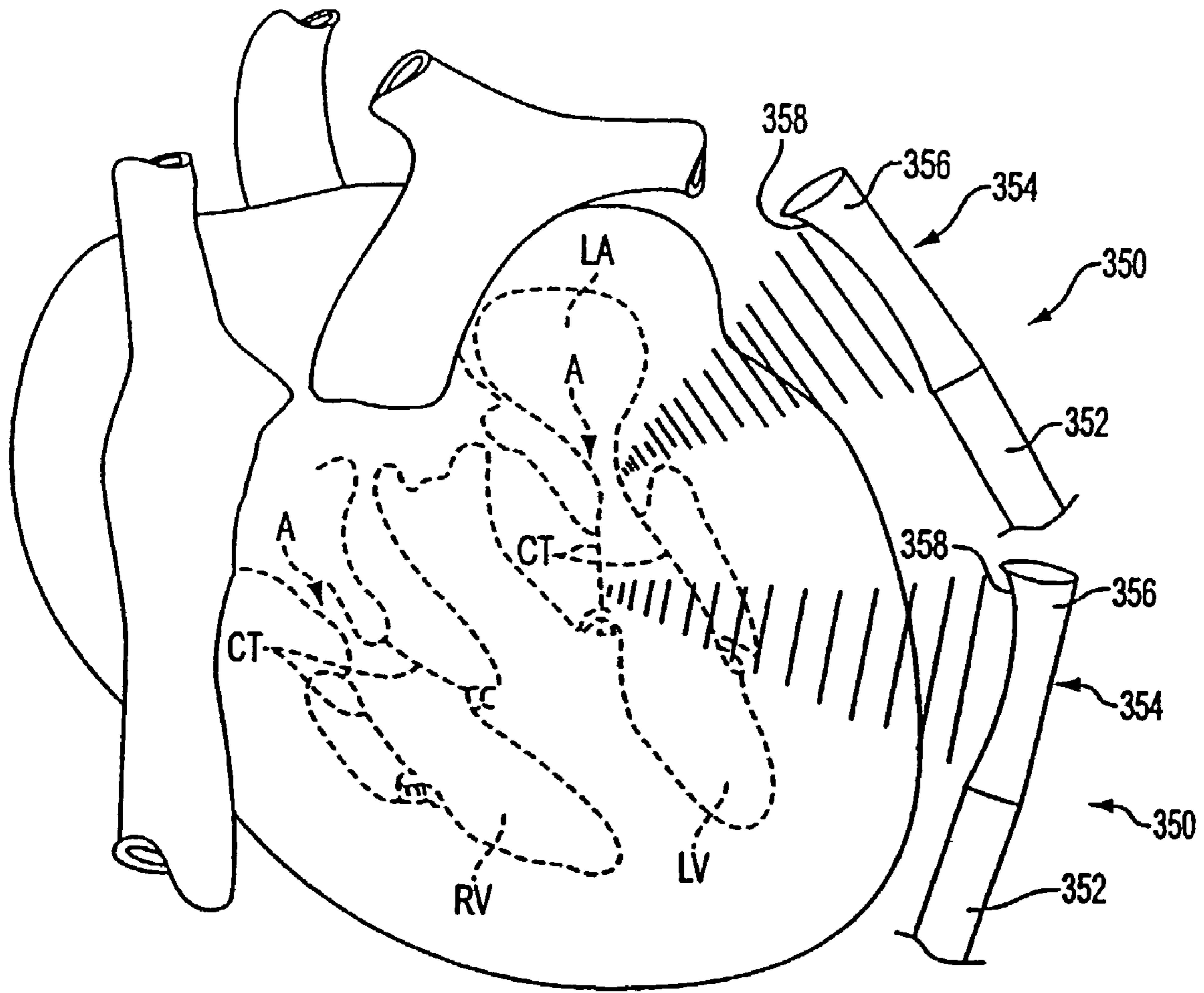

FIG. 23

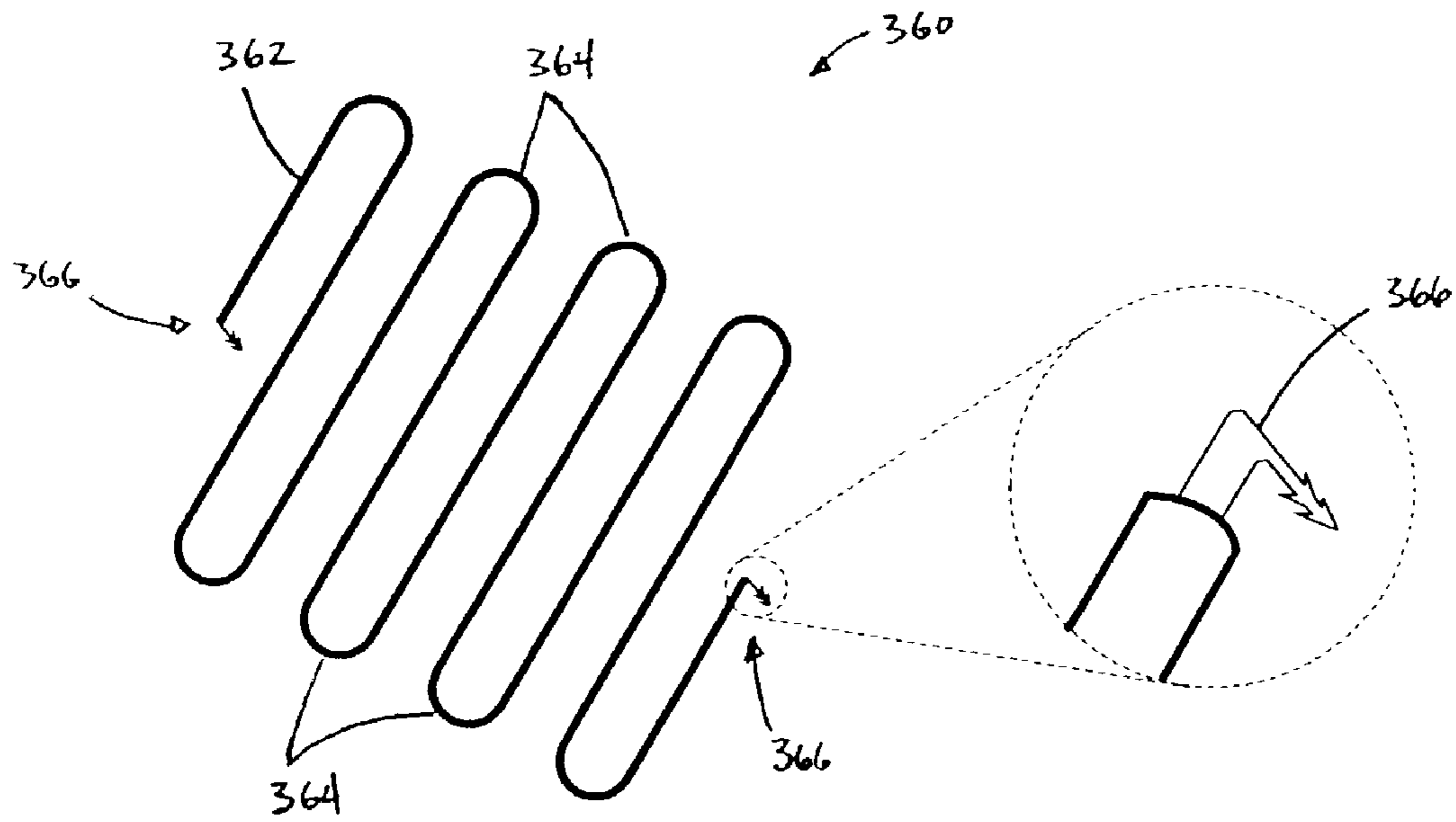

FIG. 24 A

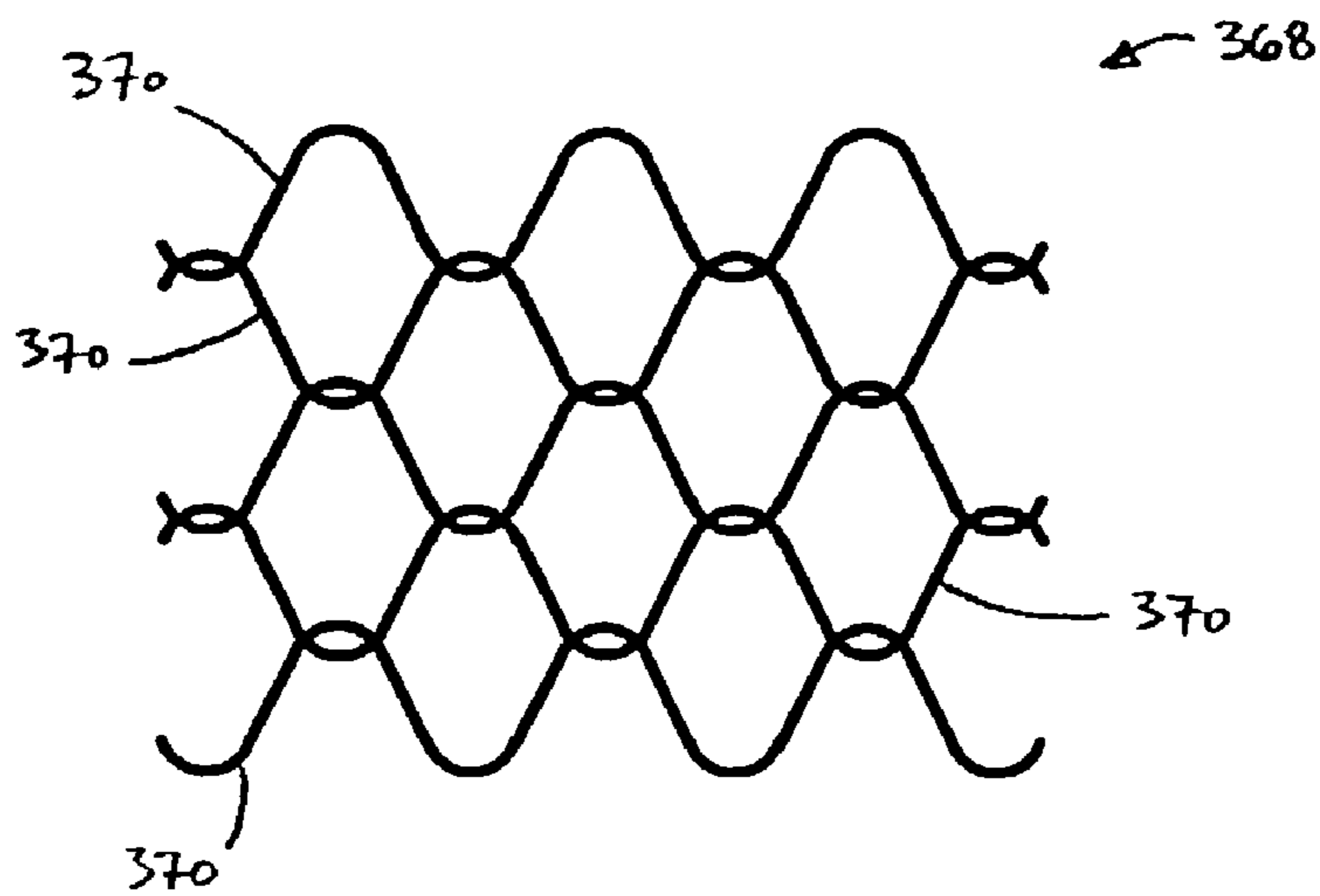

FIG. 24 B

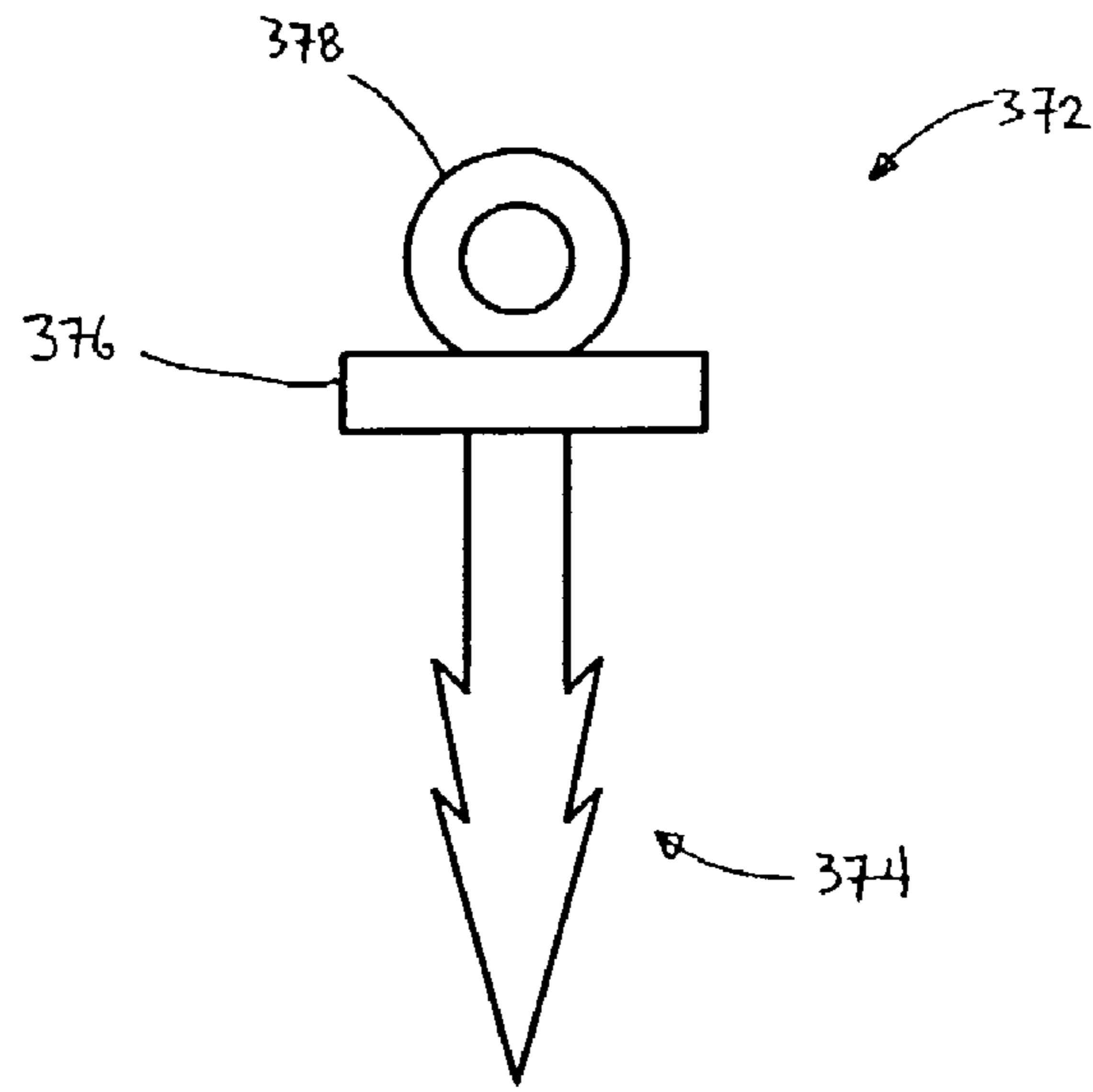

FIG. 25 A

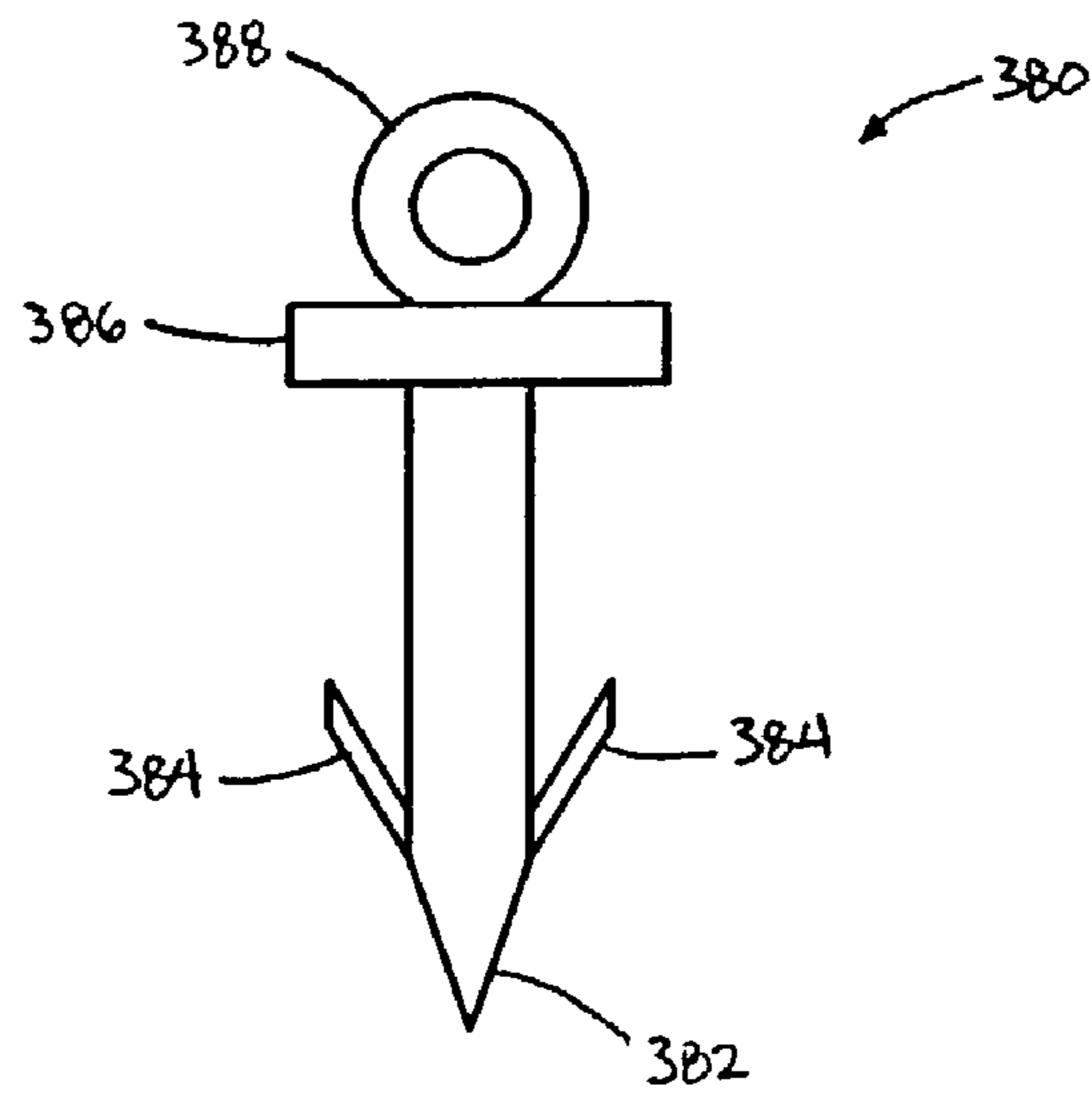

FIG. 25 B

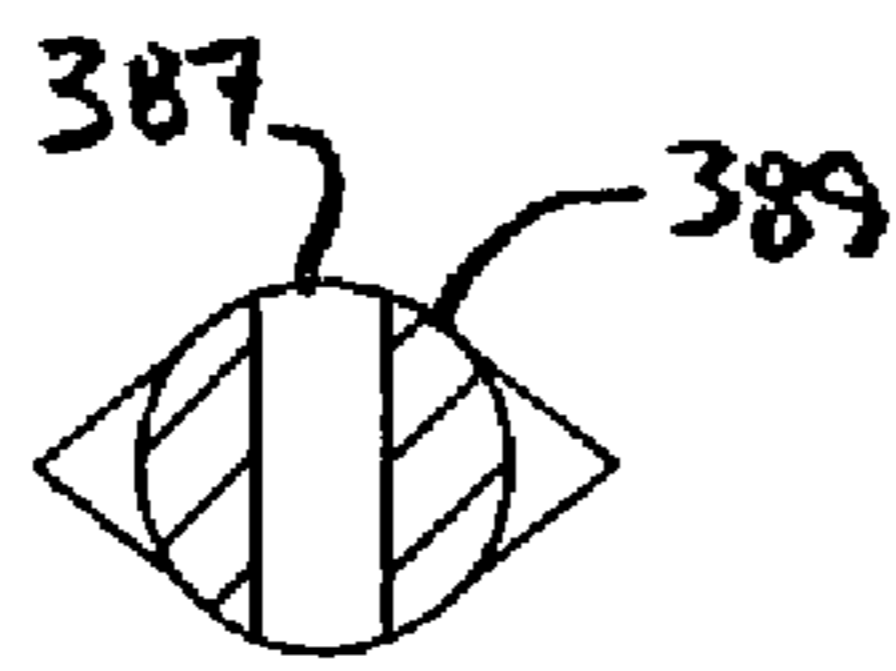

FIG. 25C

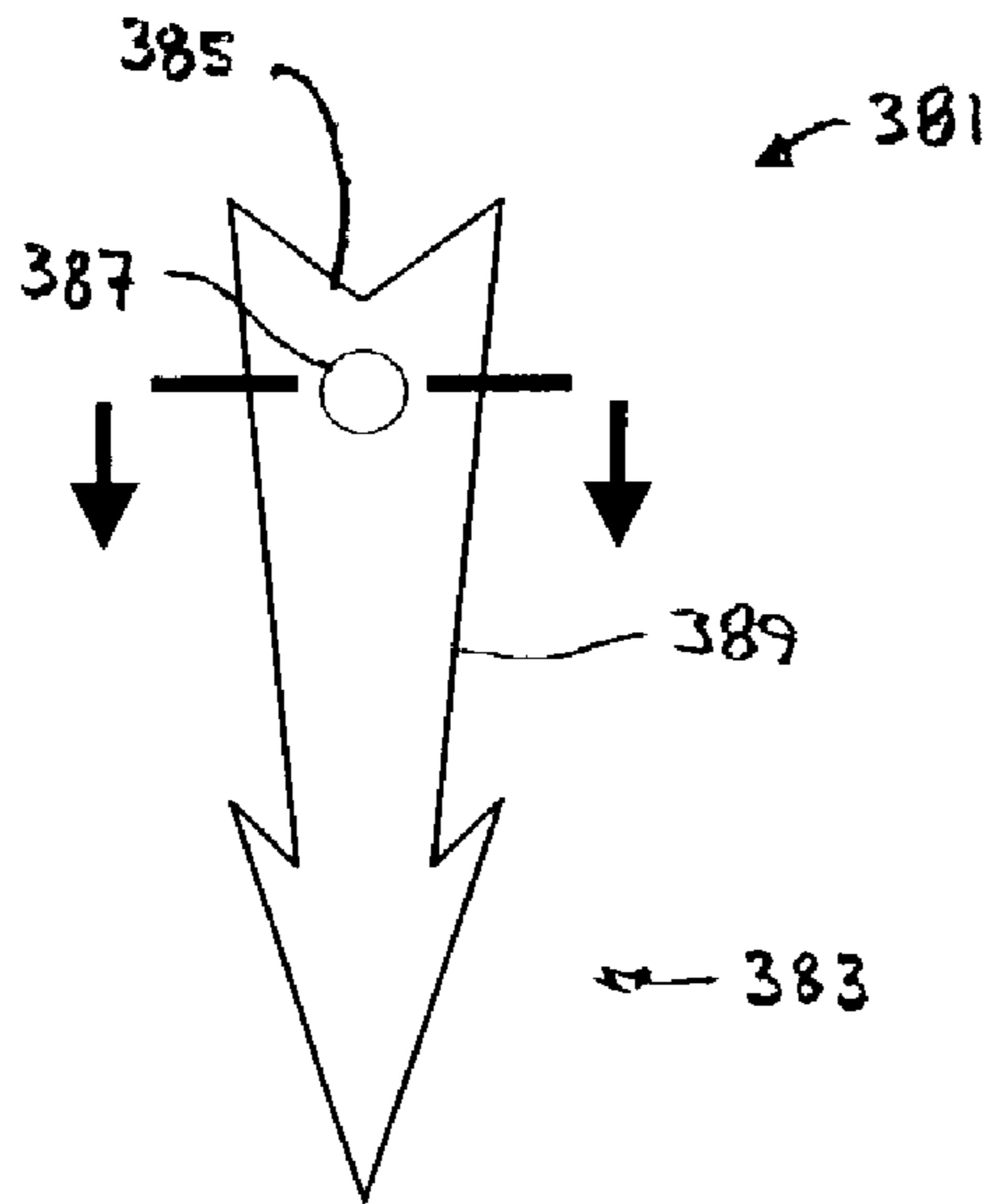

FIG. 25D

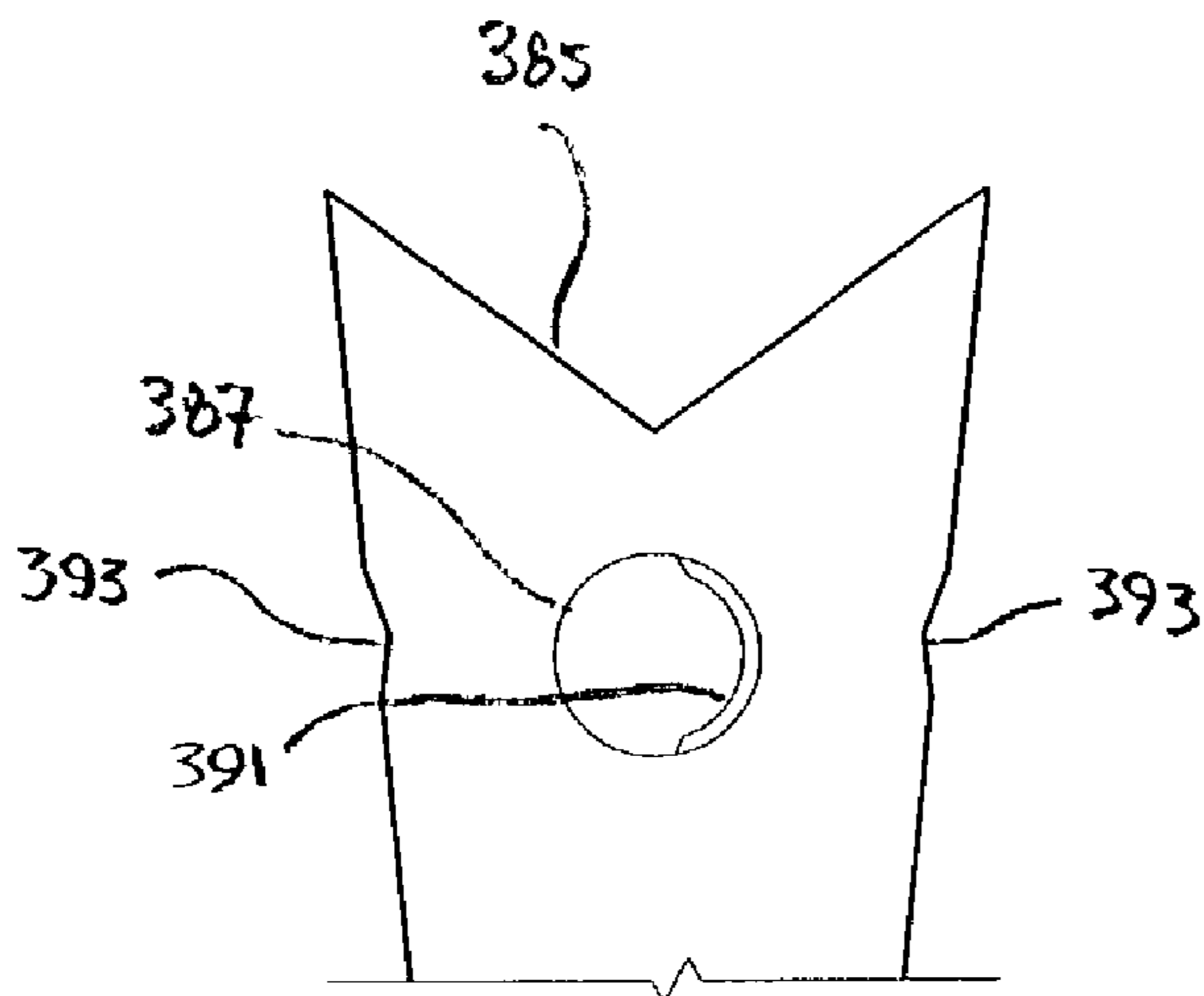

FIG. 25E

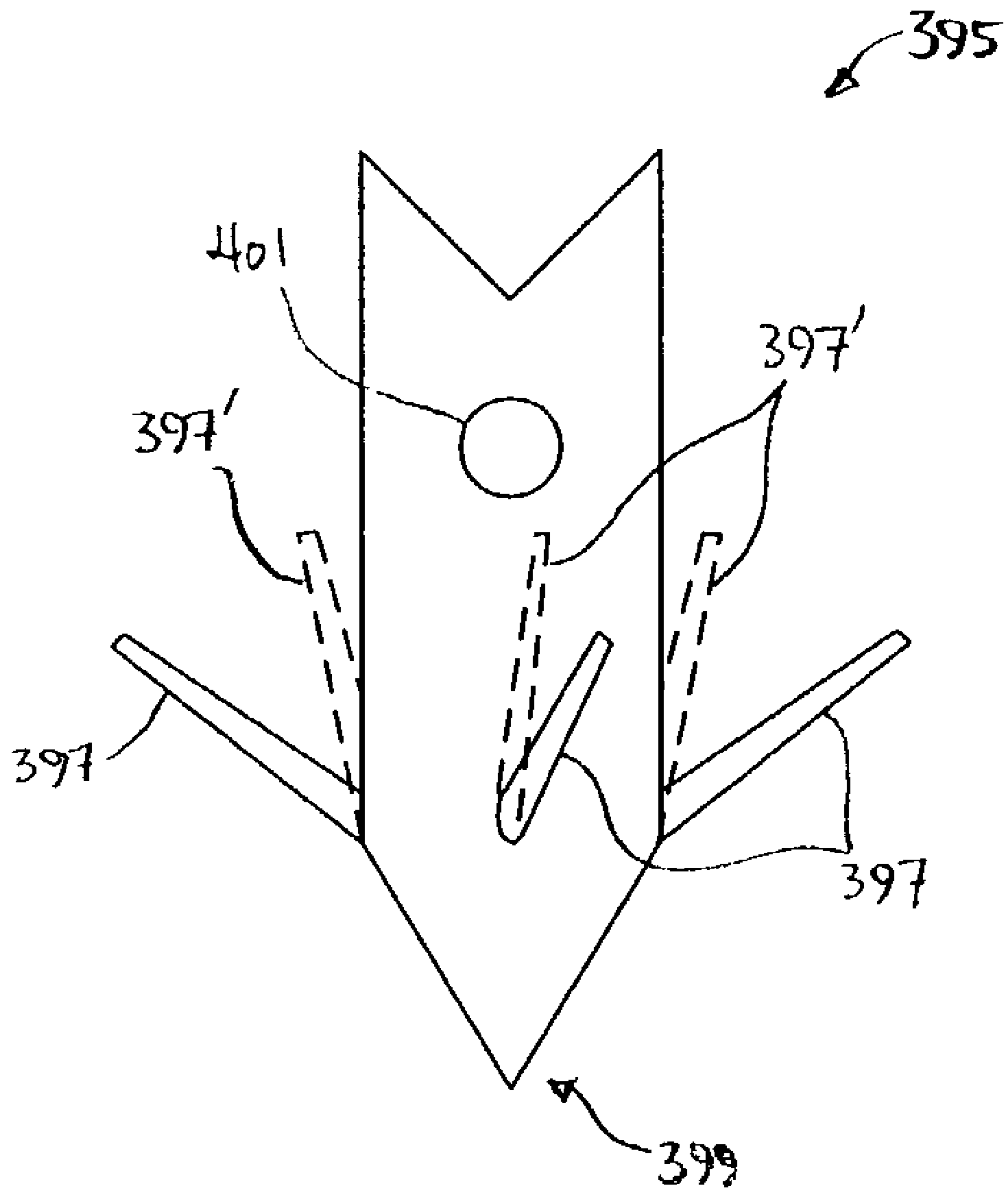

FIG. 25F

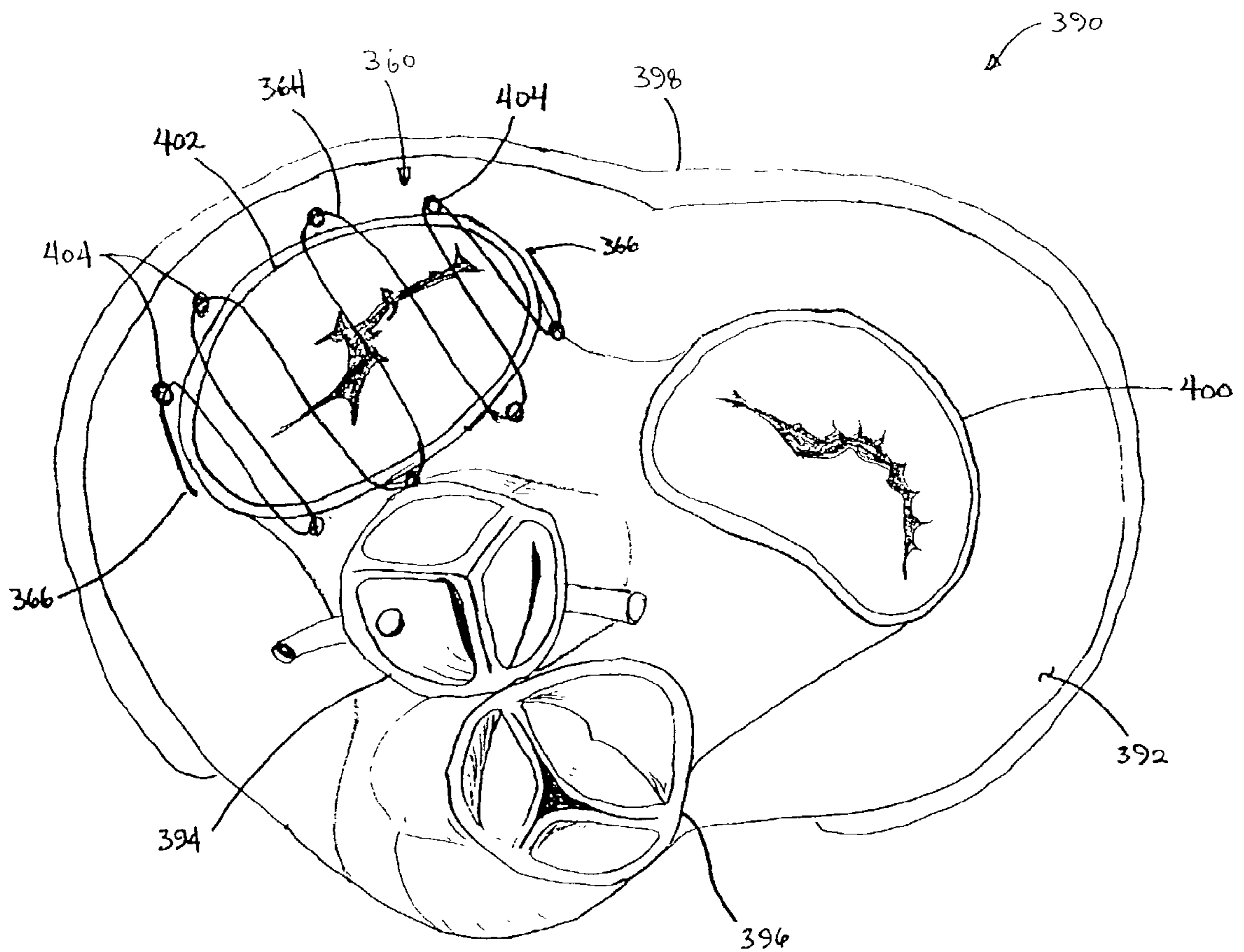

FIG. 26

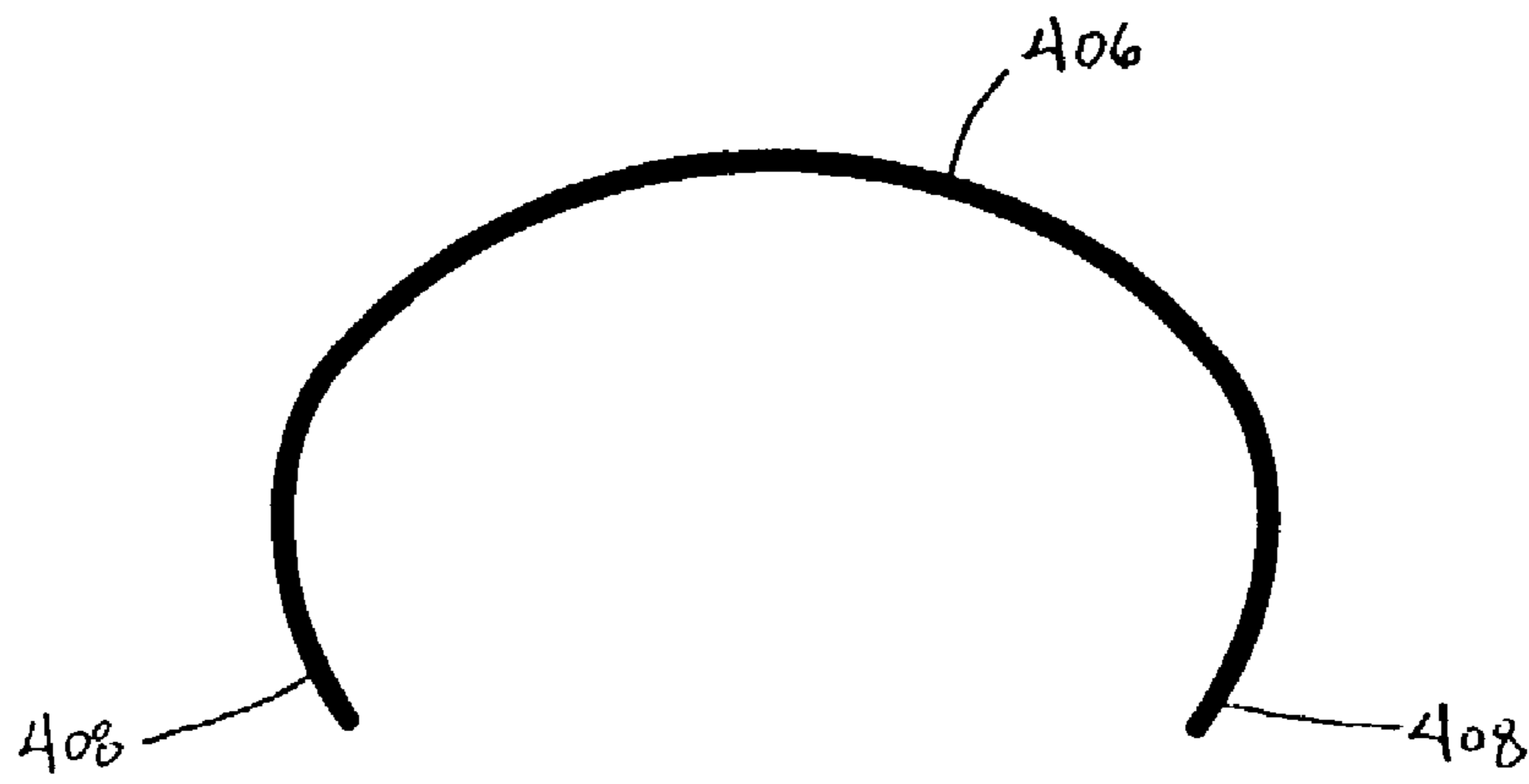

FIG. 27 A

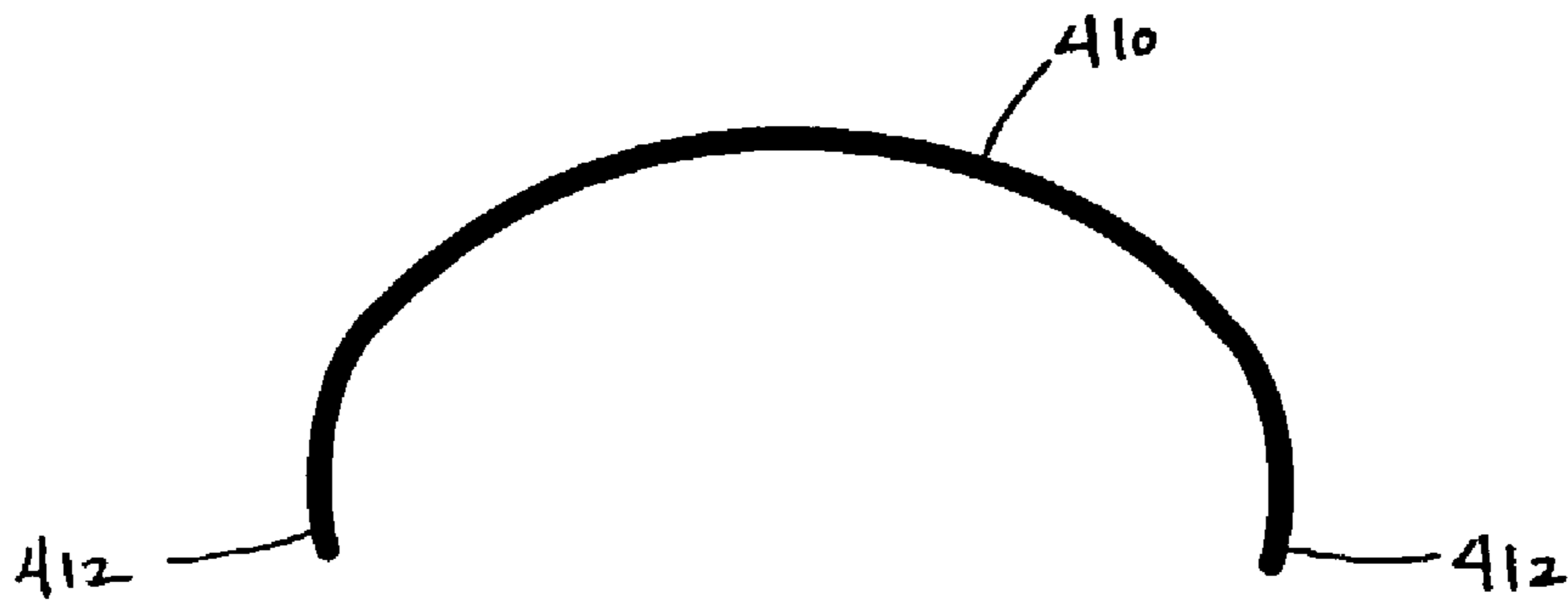

FIG. 27 B

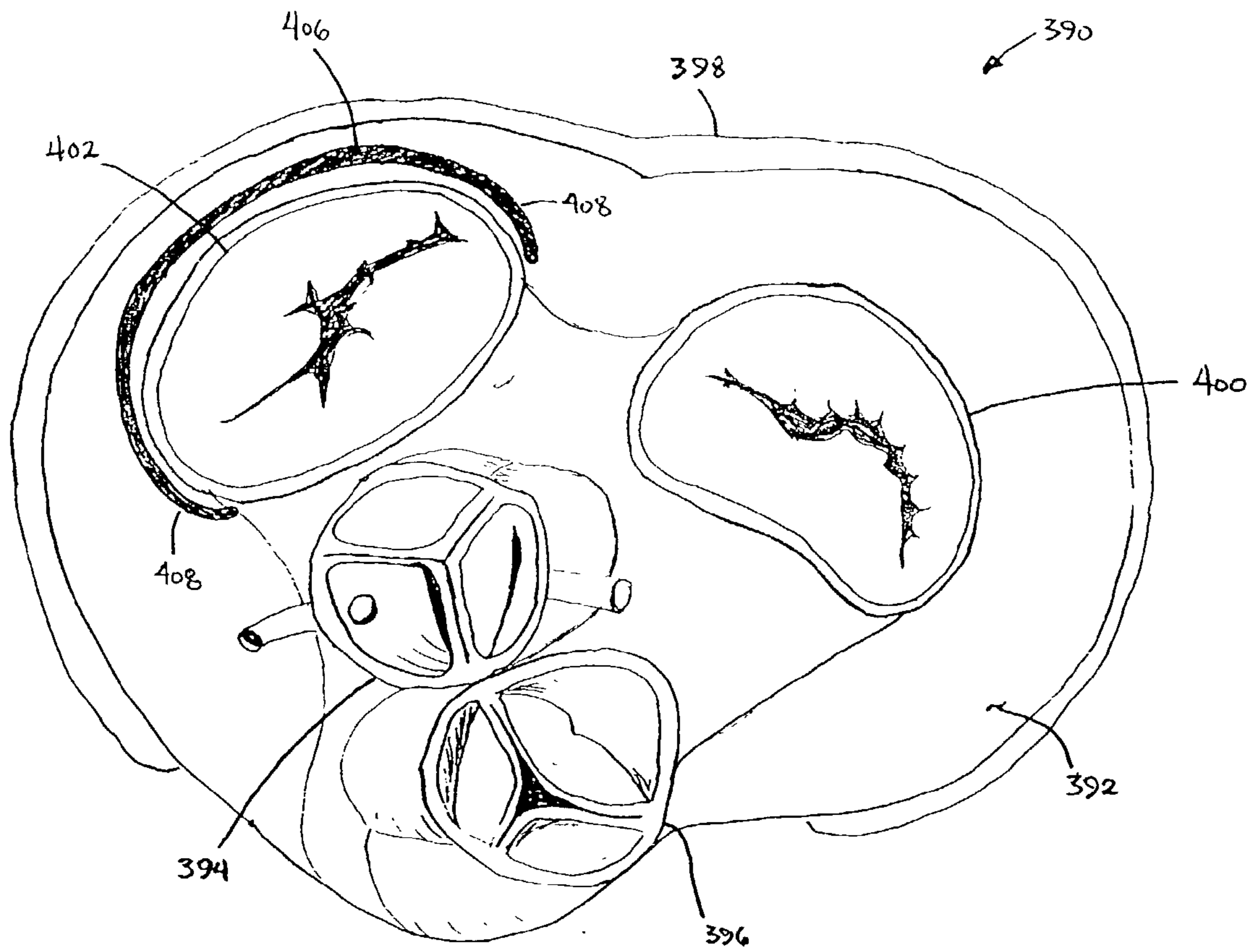
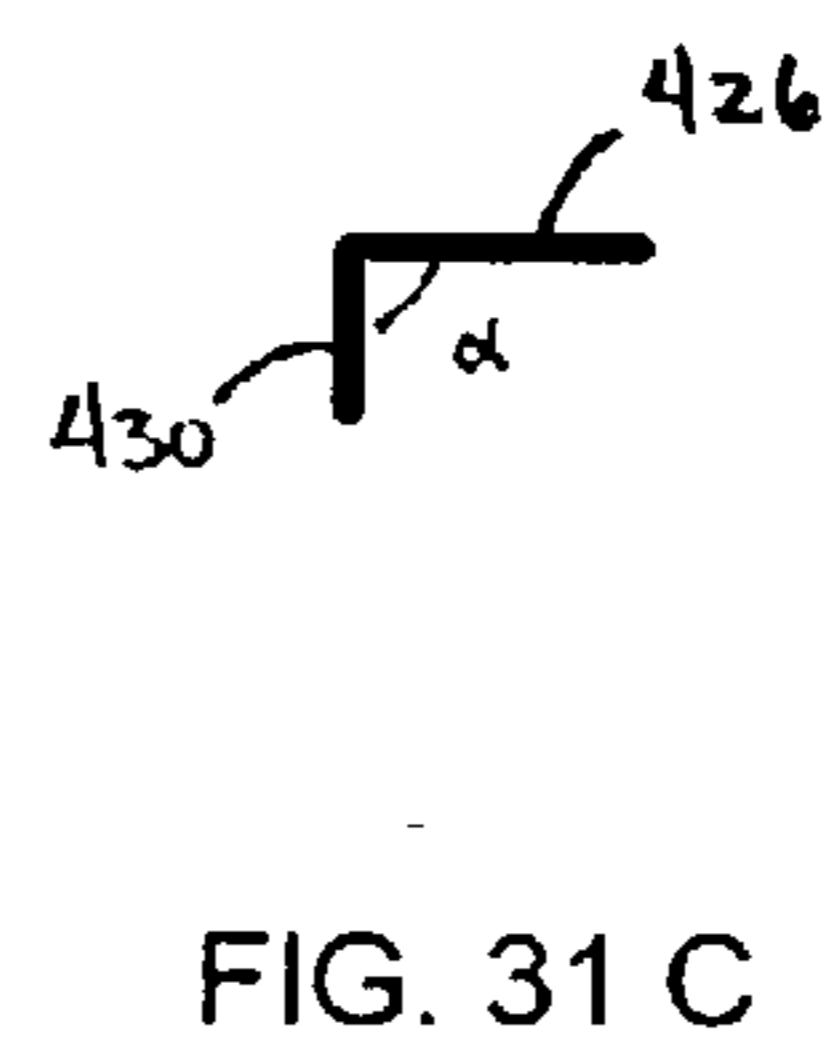
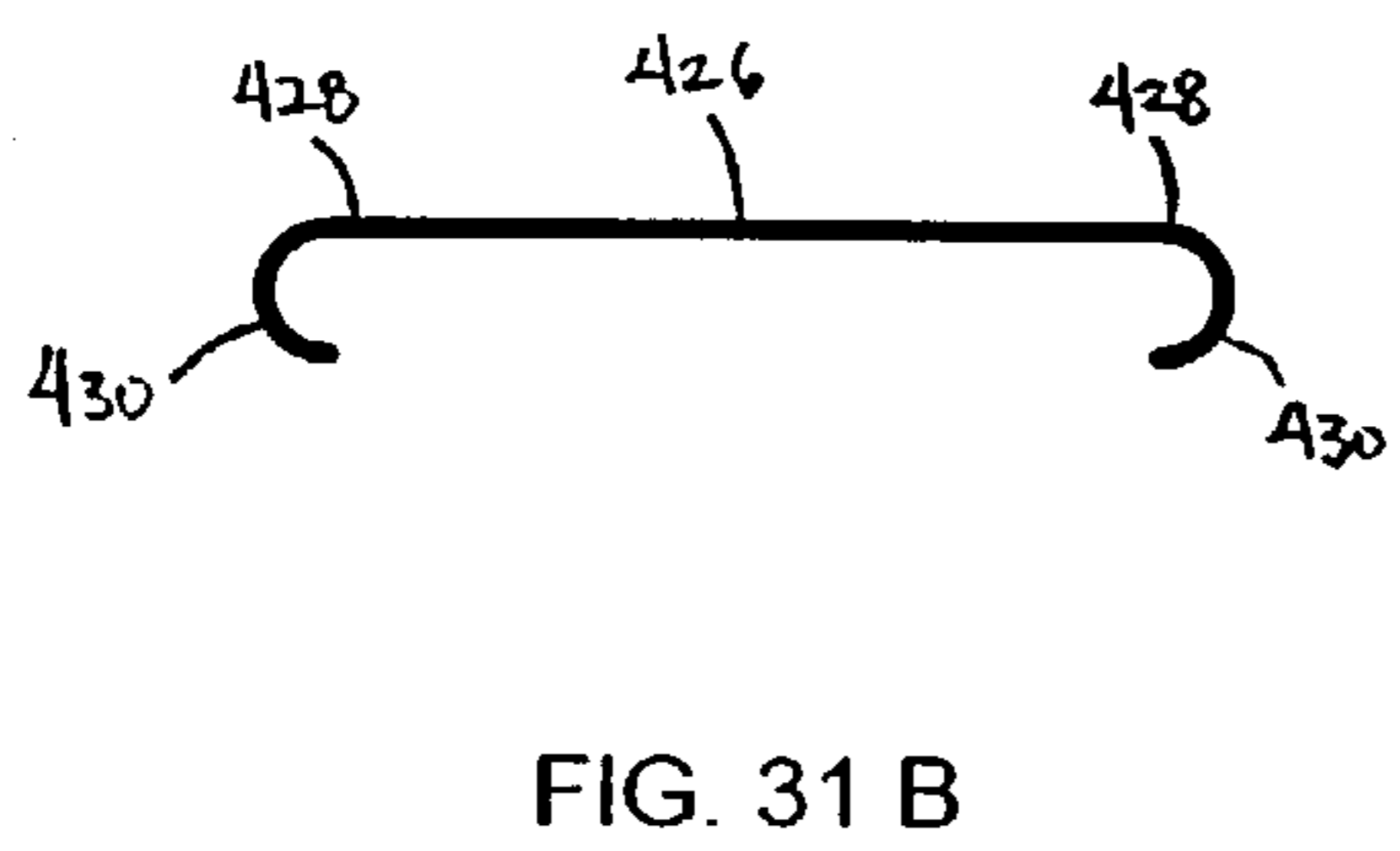
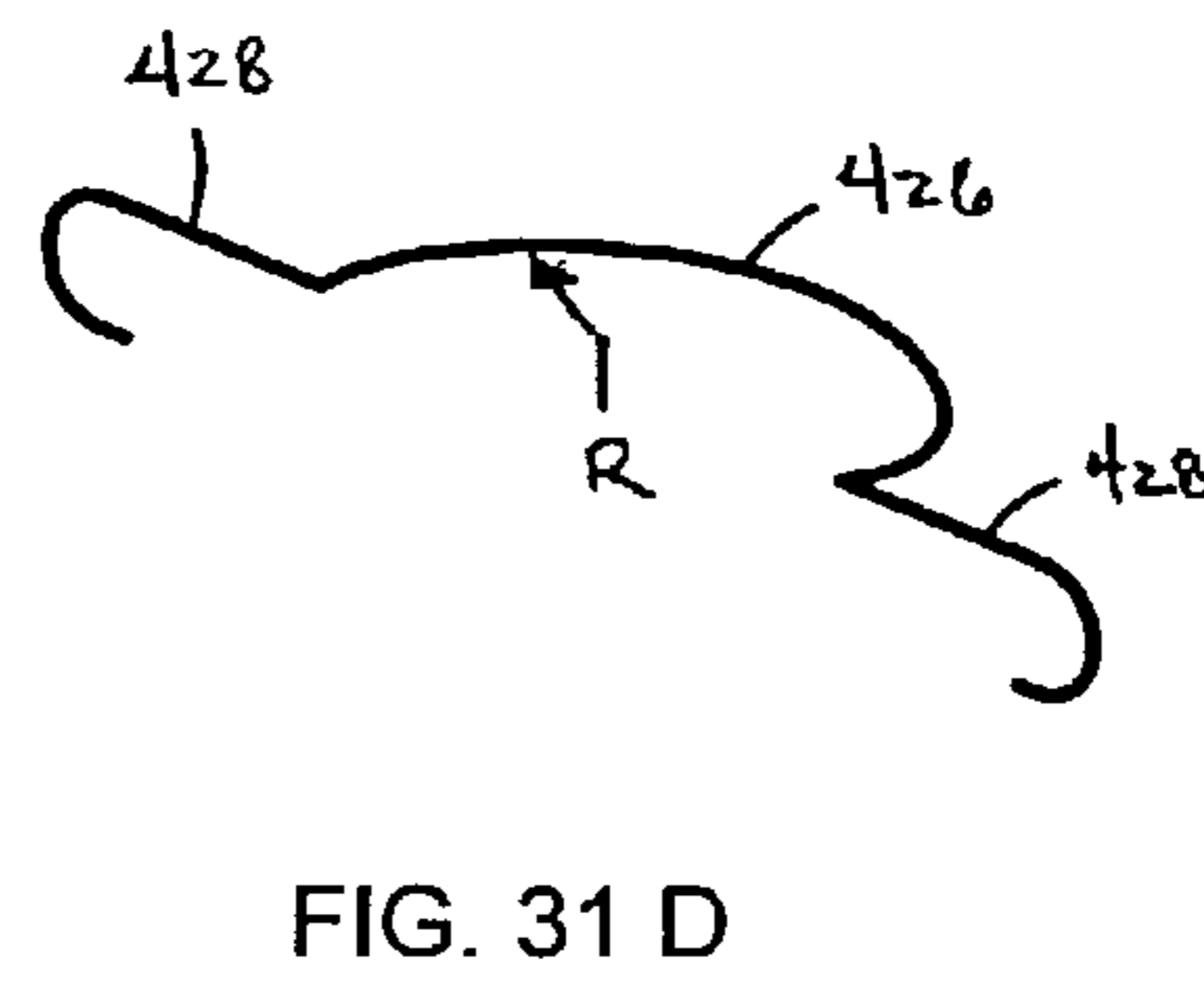
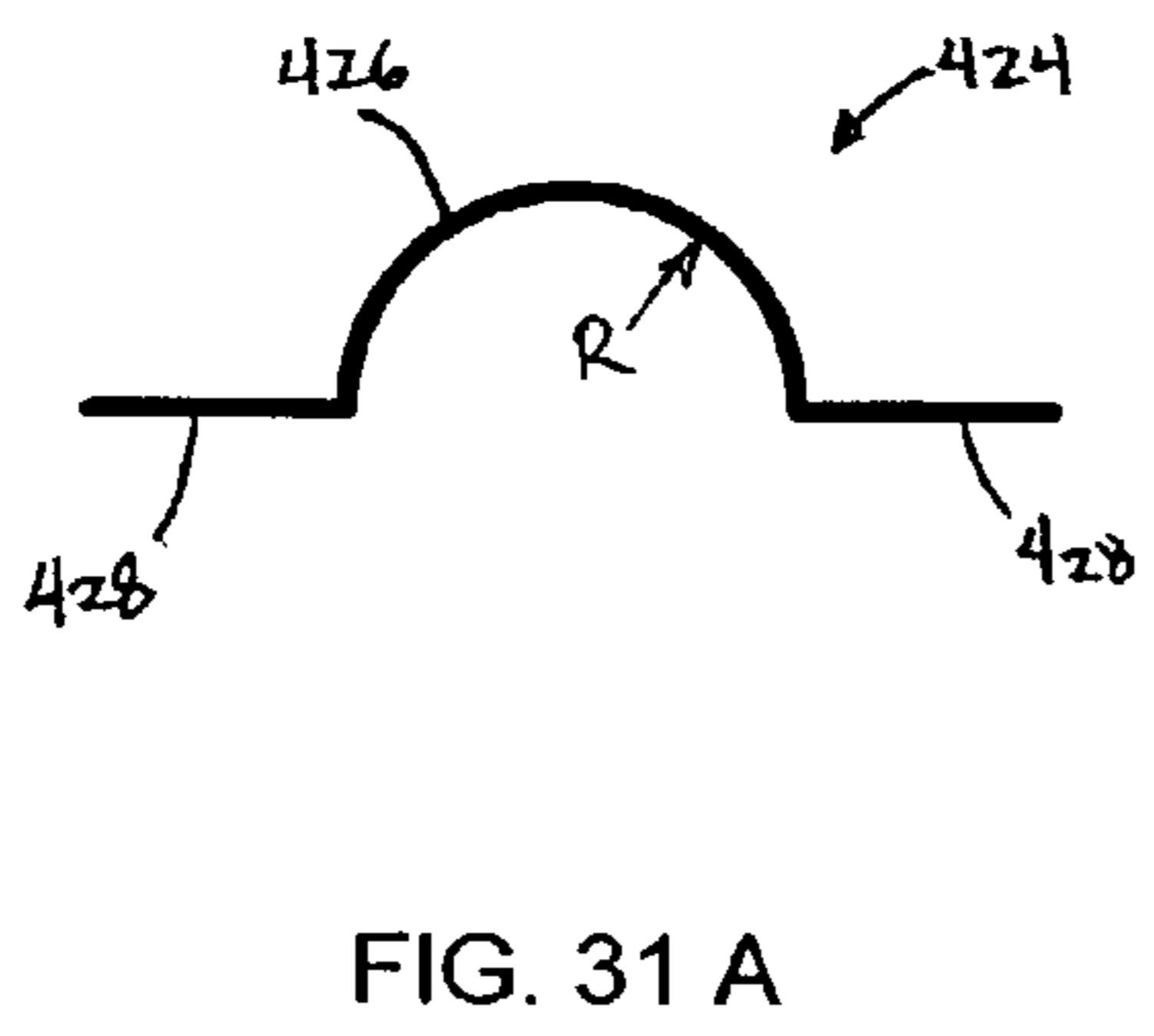
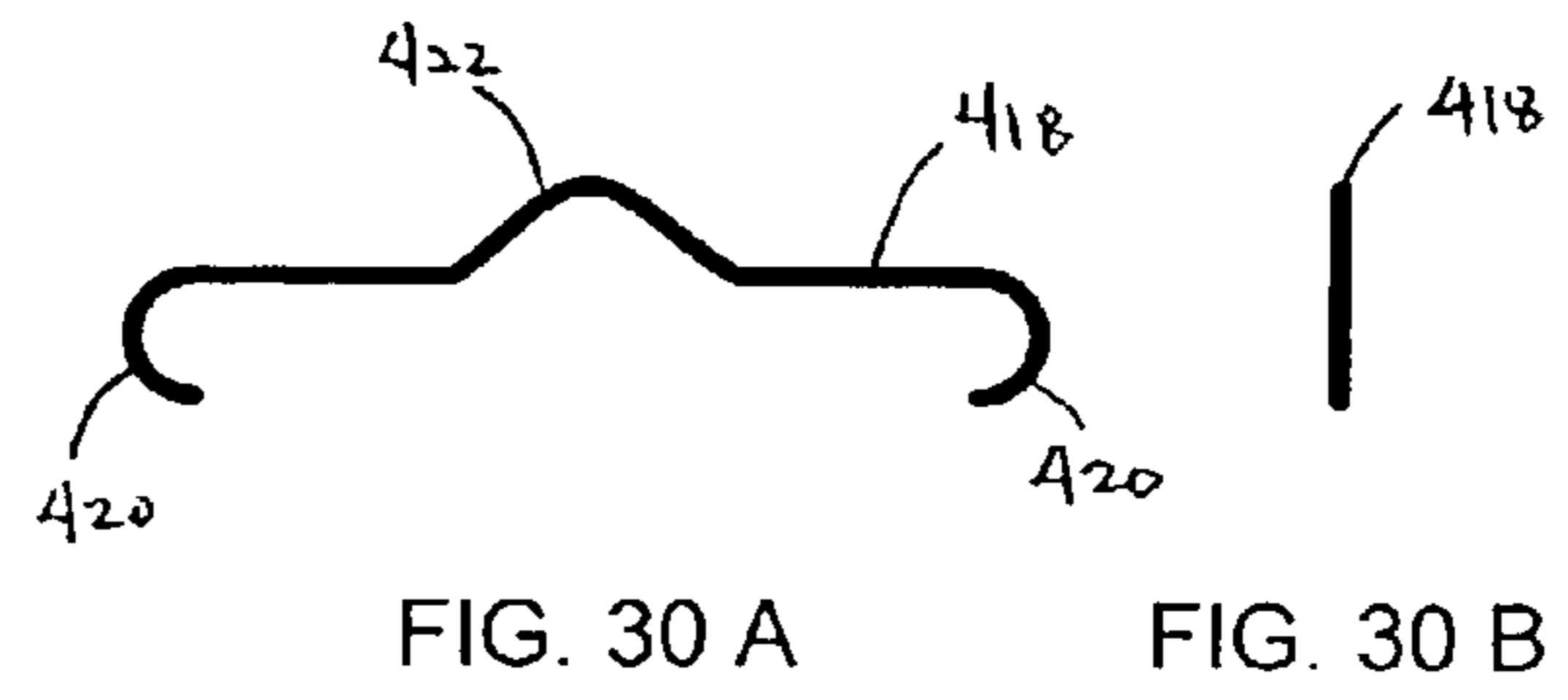
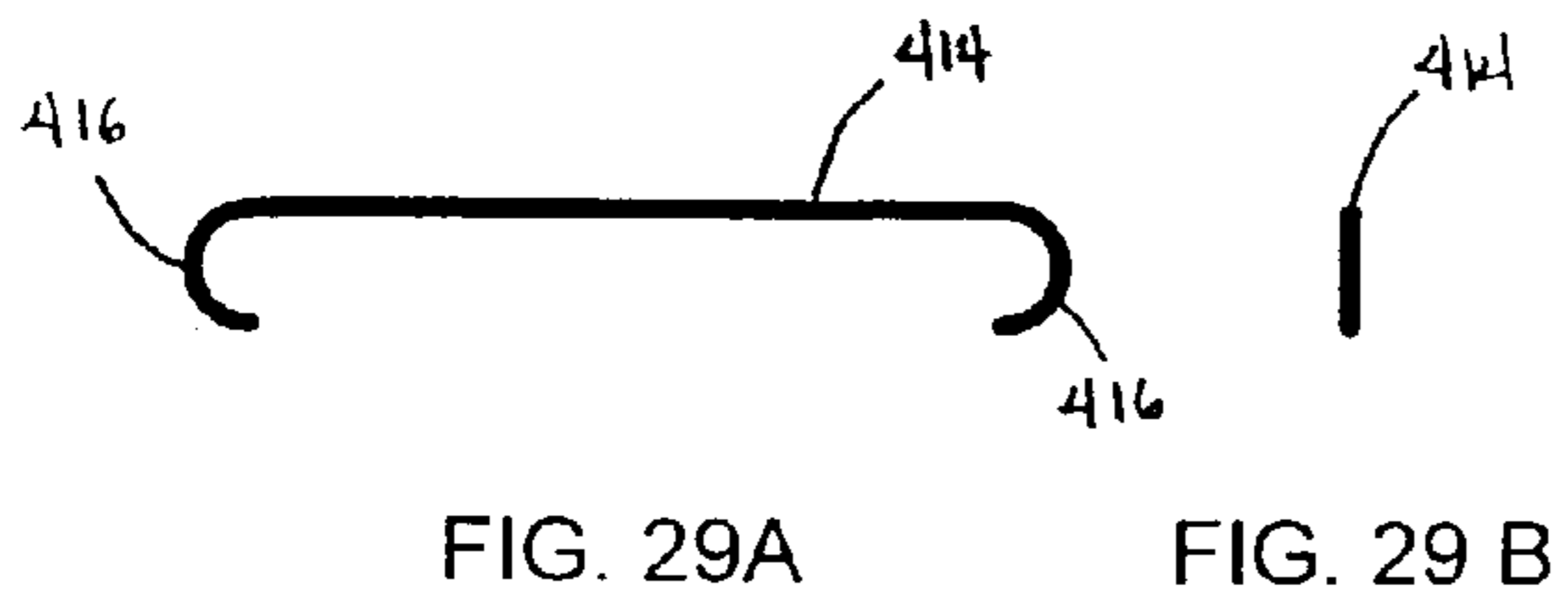

FIG. 28



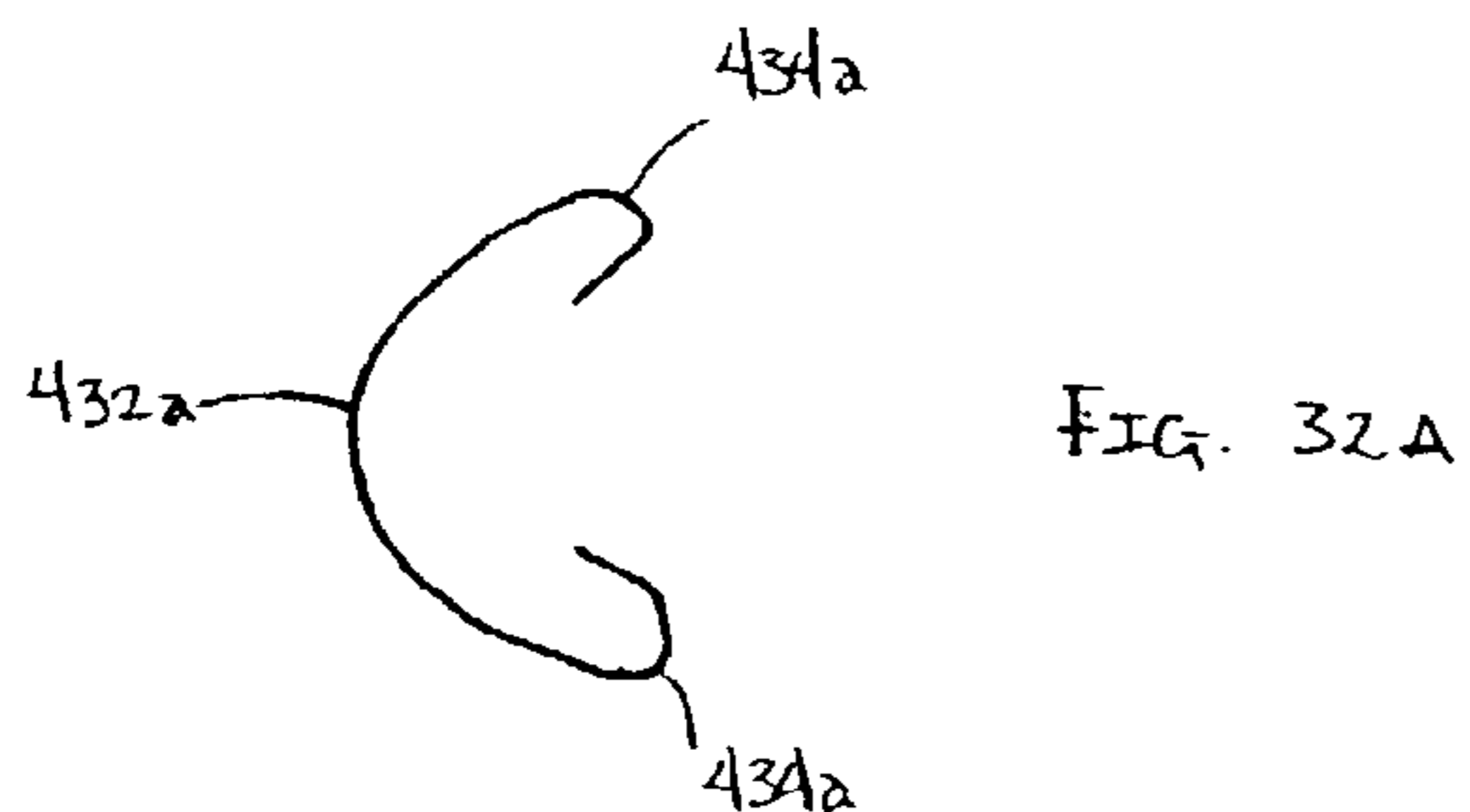

FIG. 32A

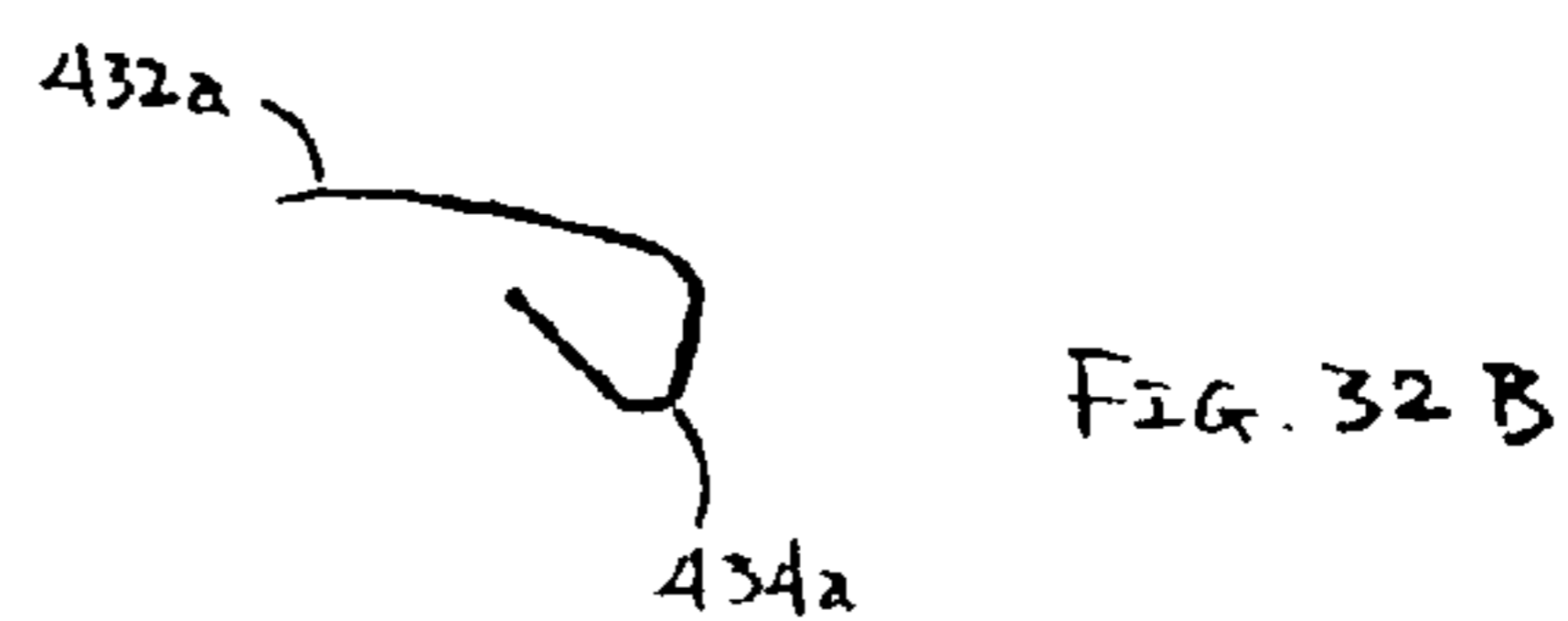

FIG. 32B

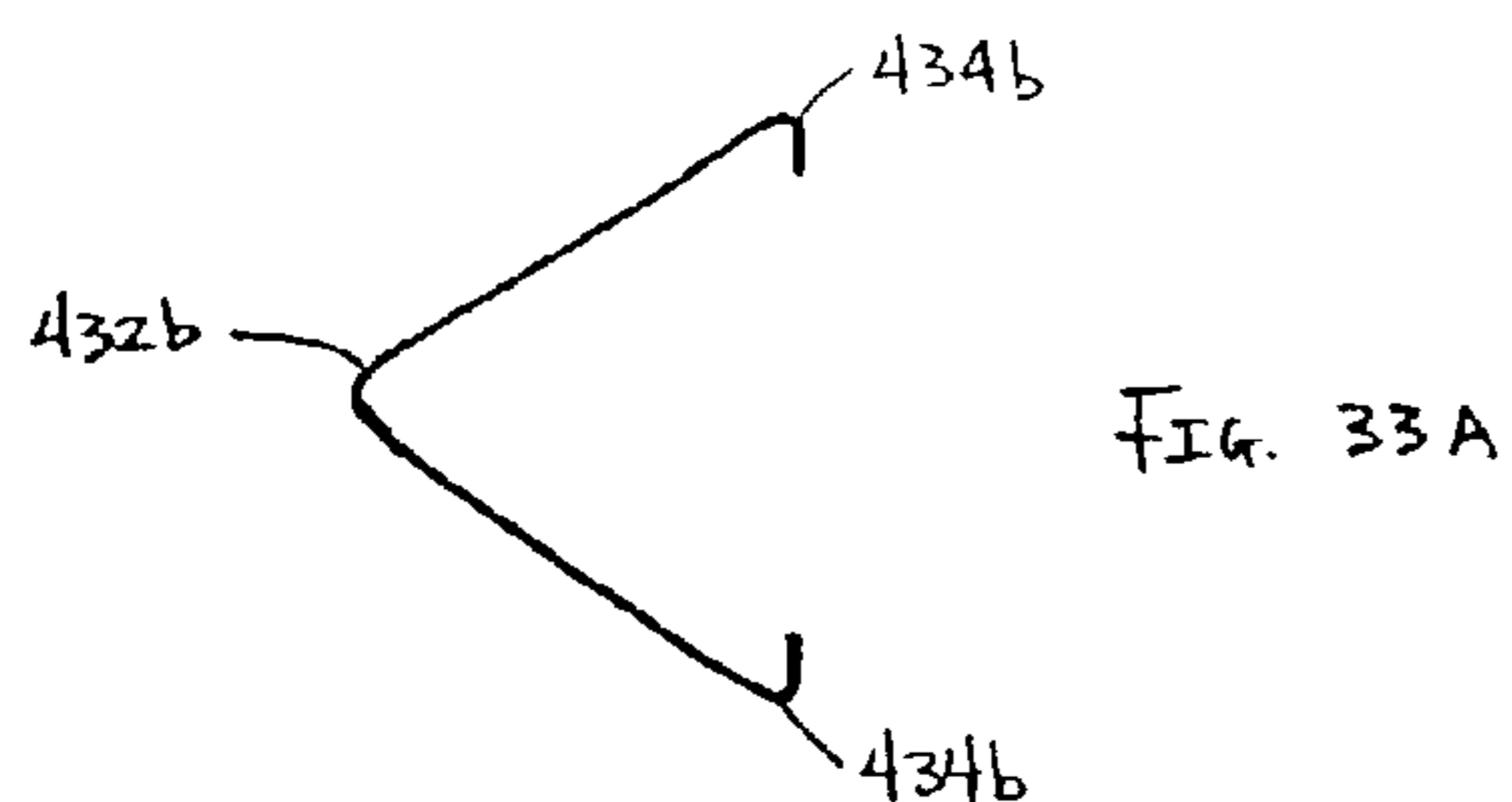

FIG. 33A

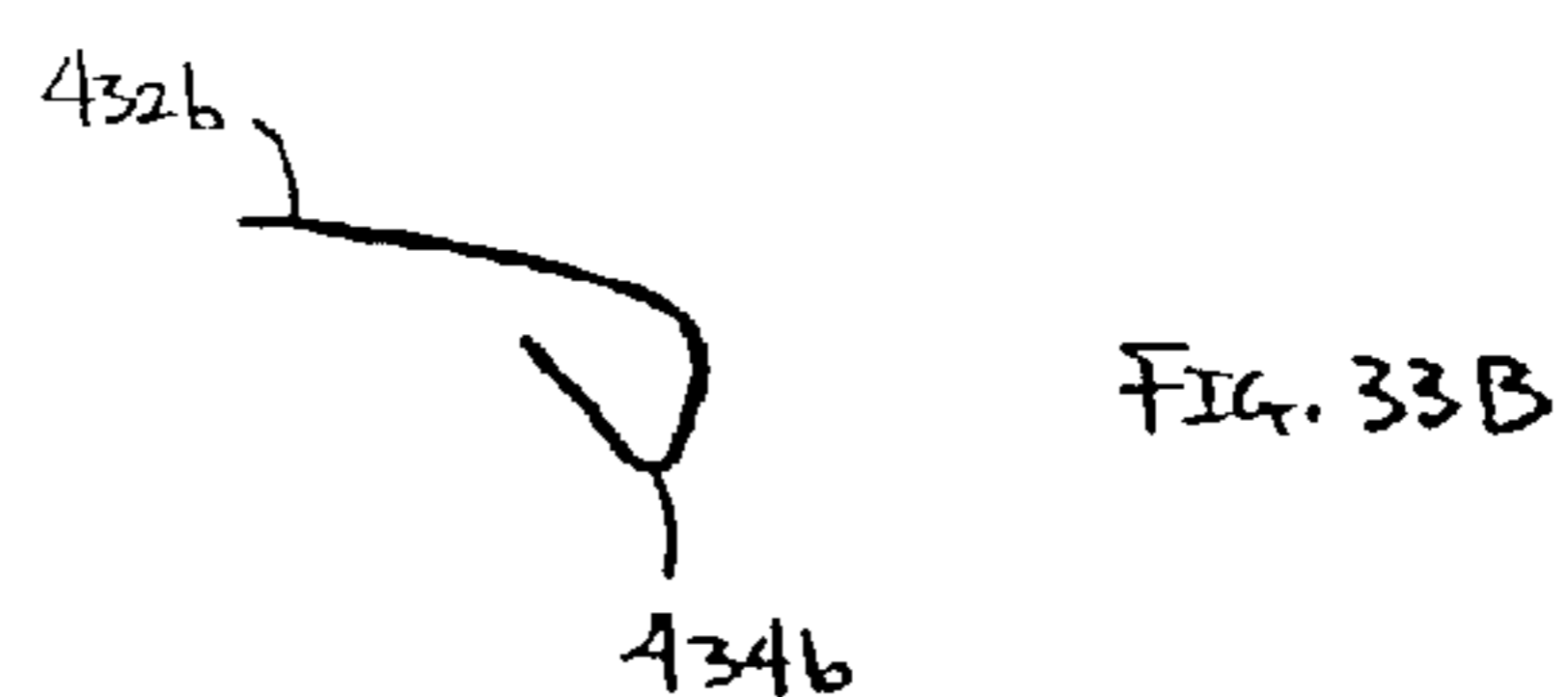

FIG. 33B

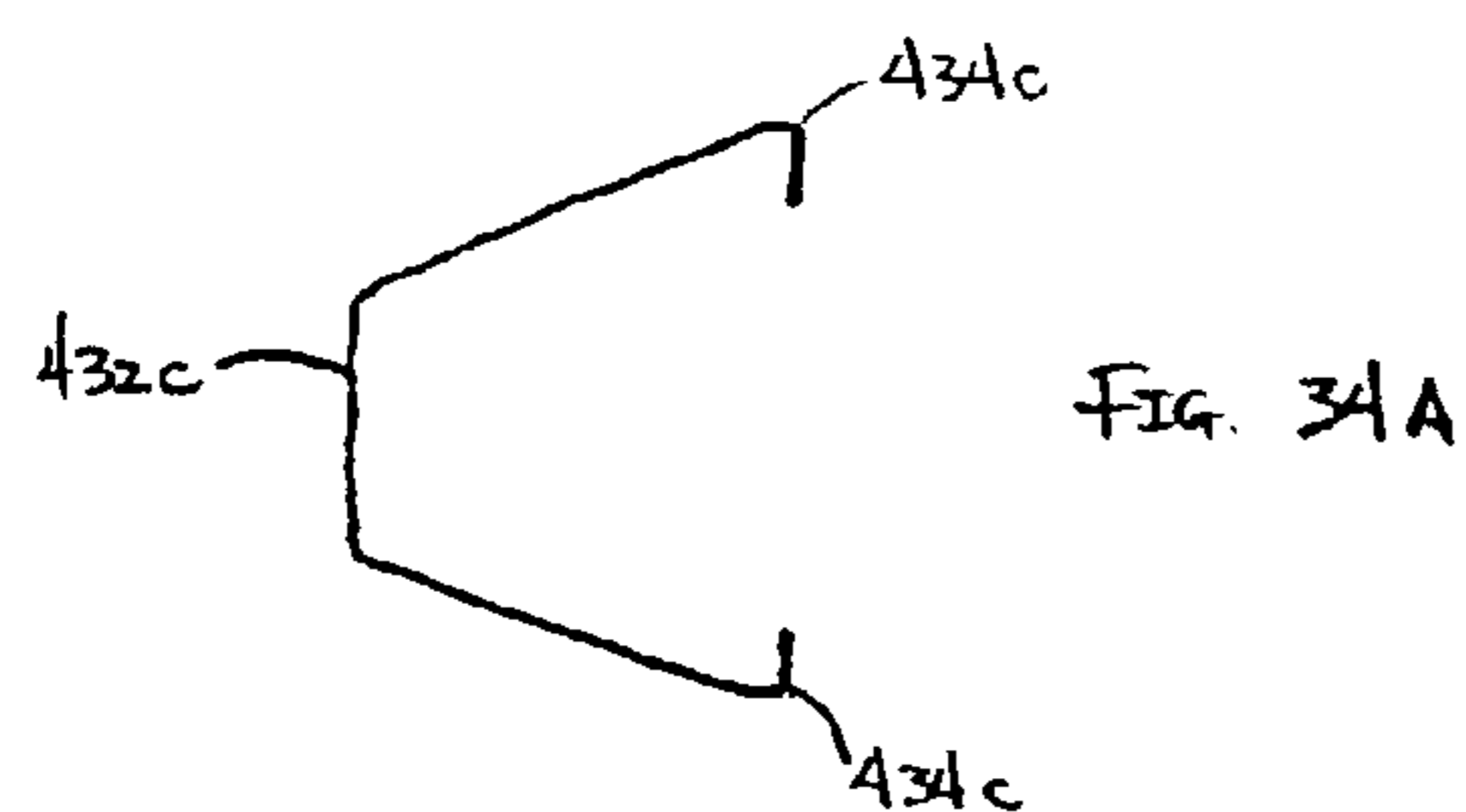

FIG. 34A

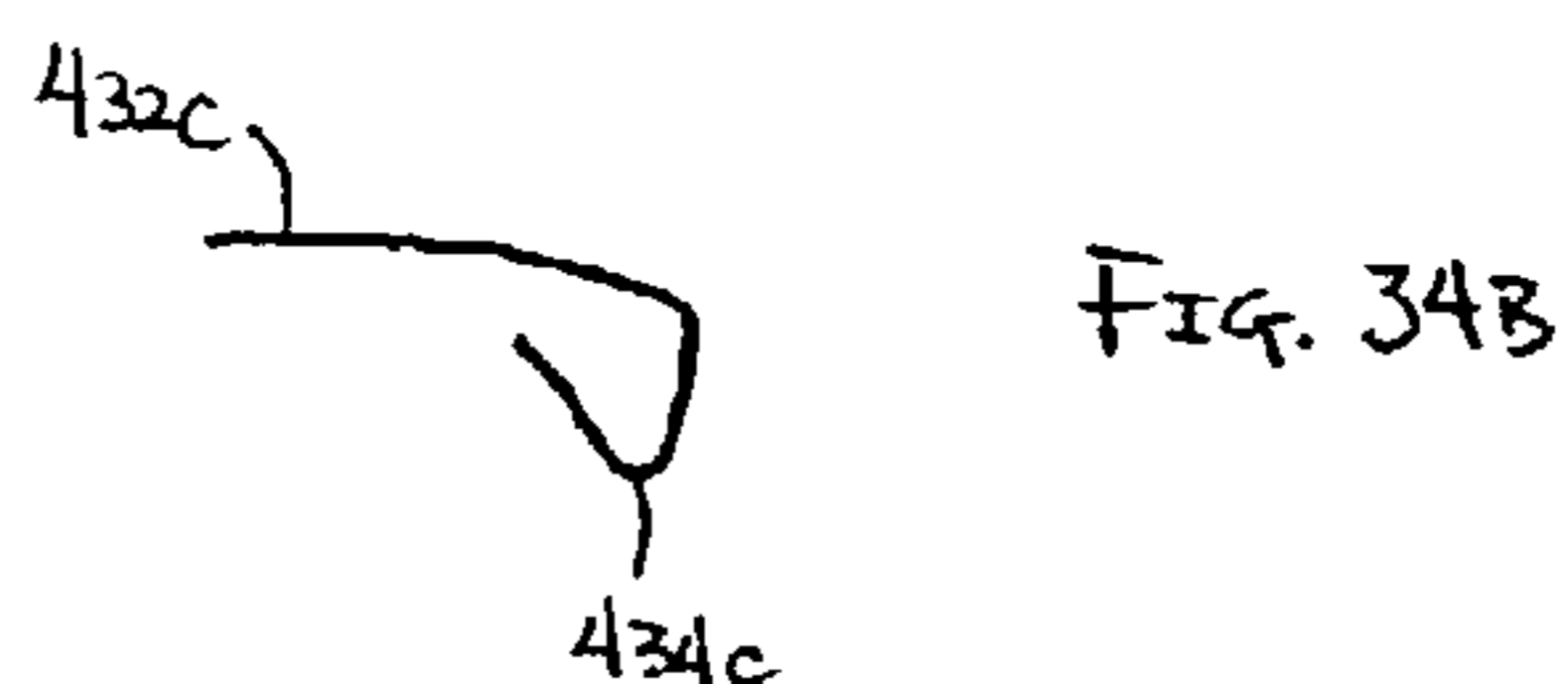

FIG. 34B

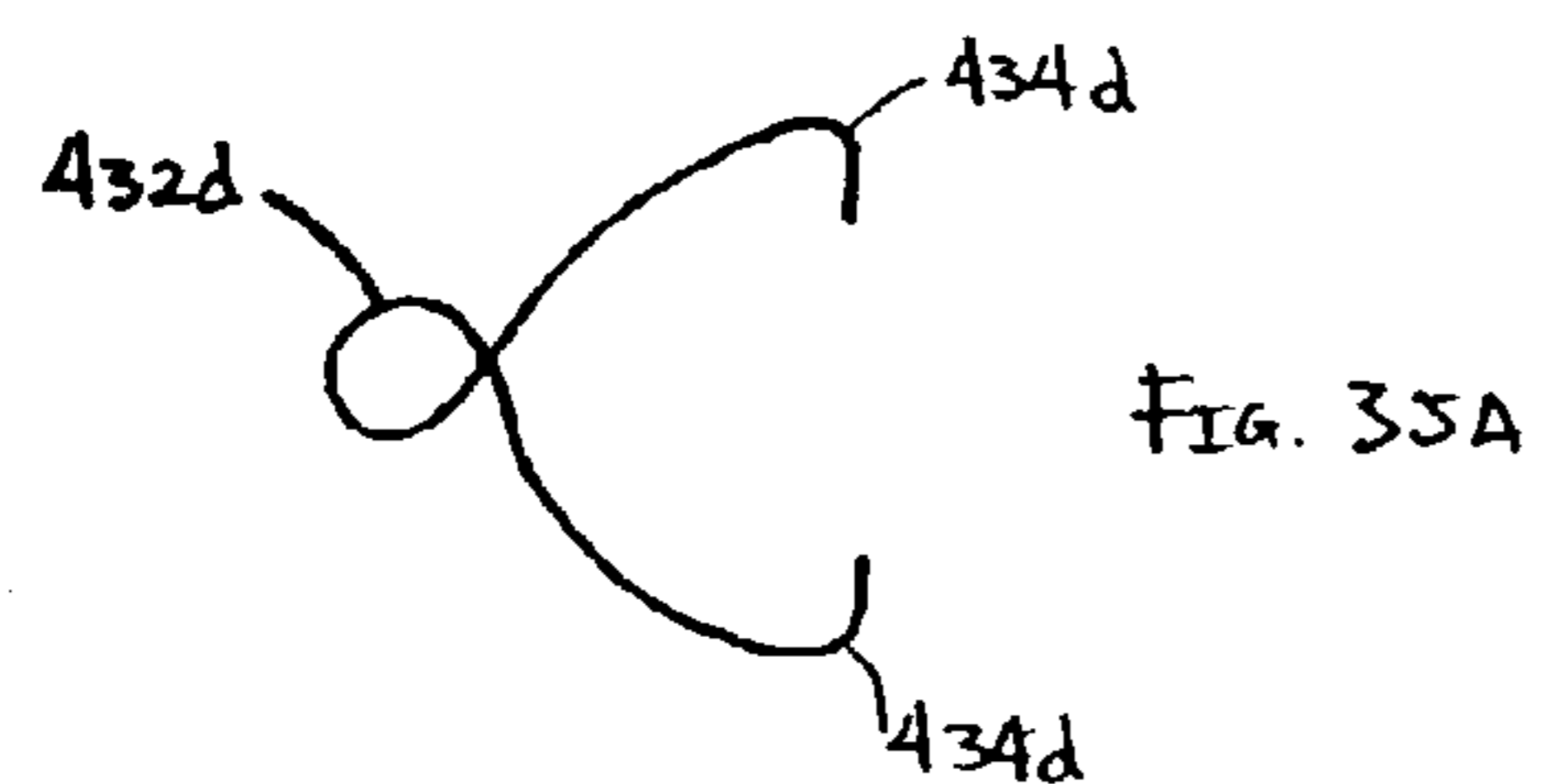

FIG. 35A

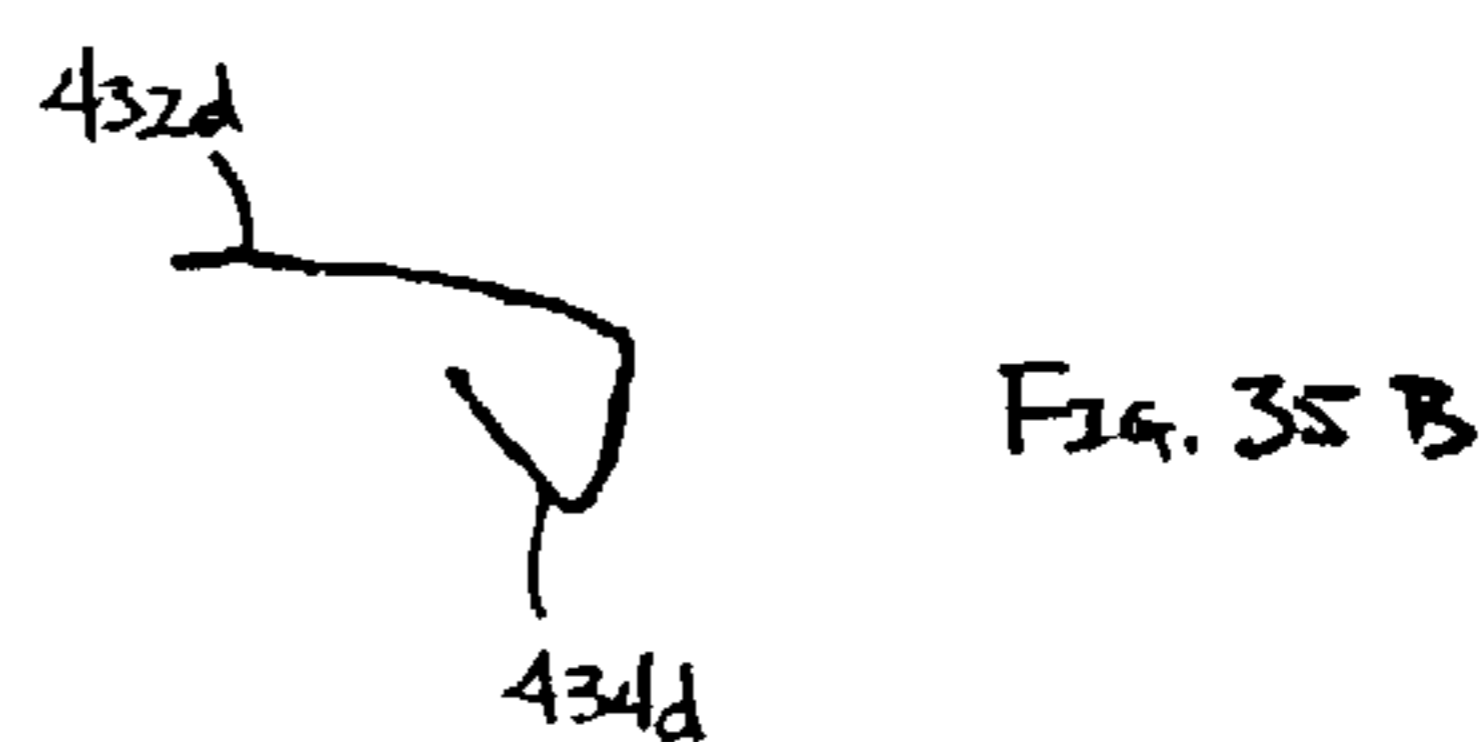

FIG. 35B

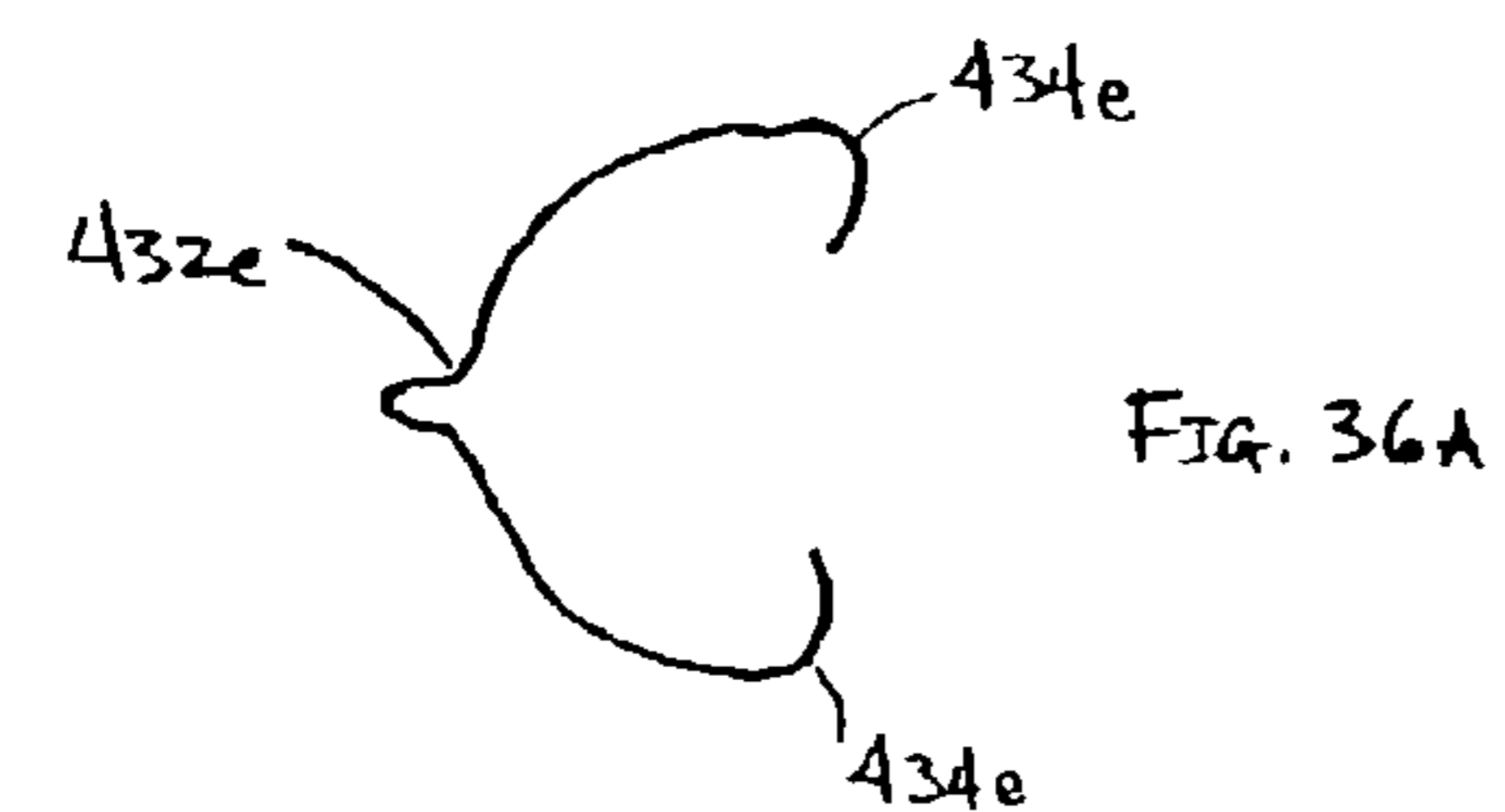

FIG. 36A

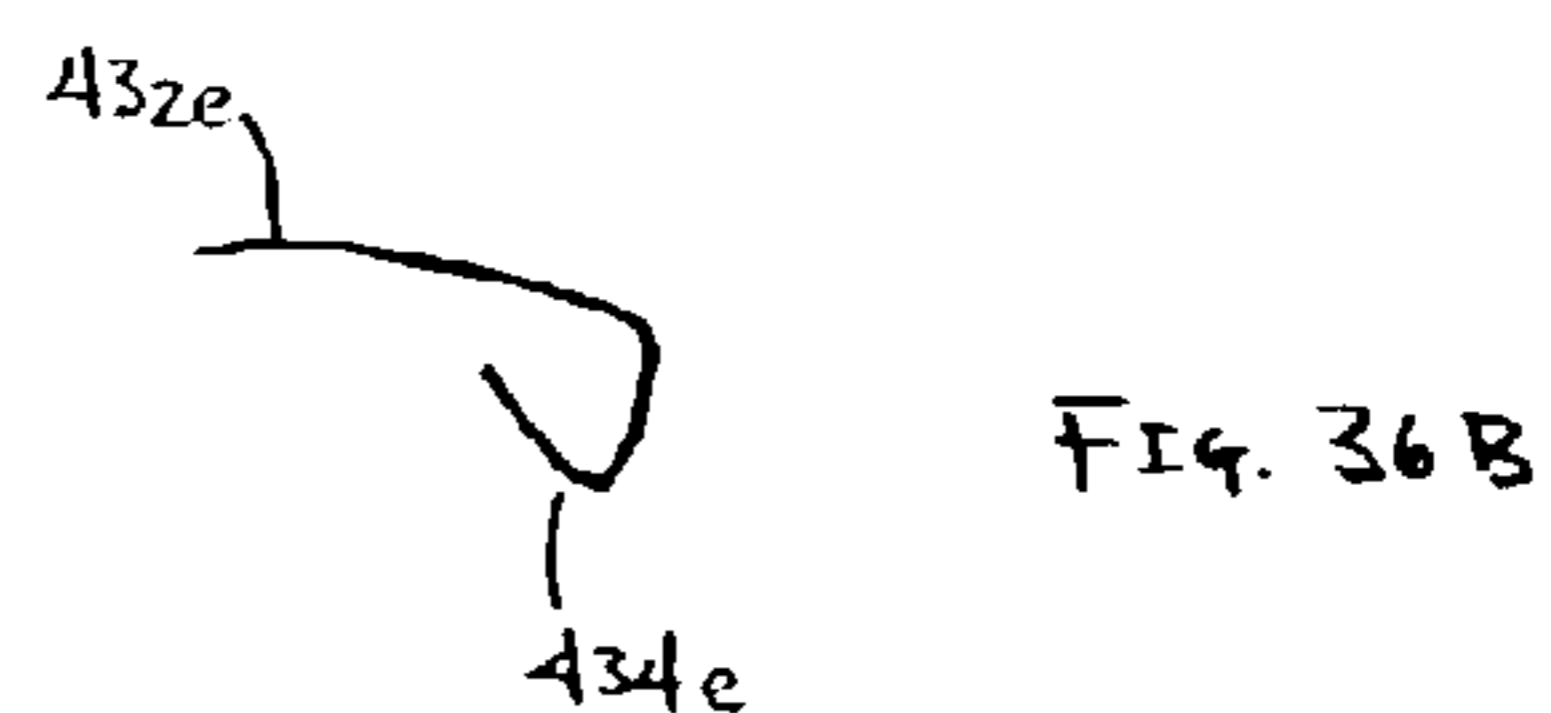

FIG. 36B

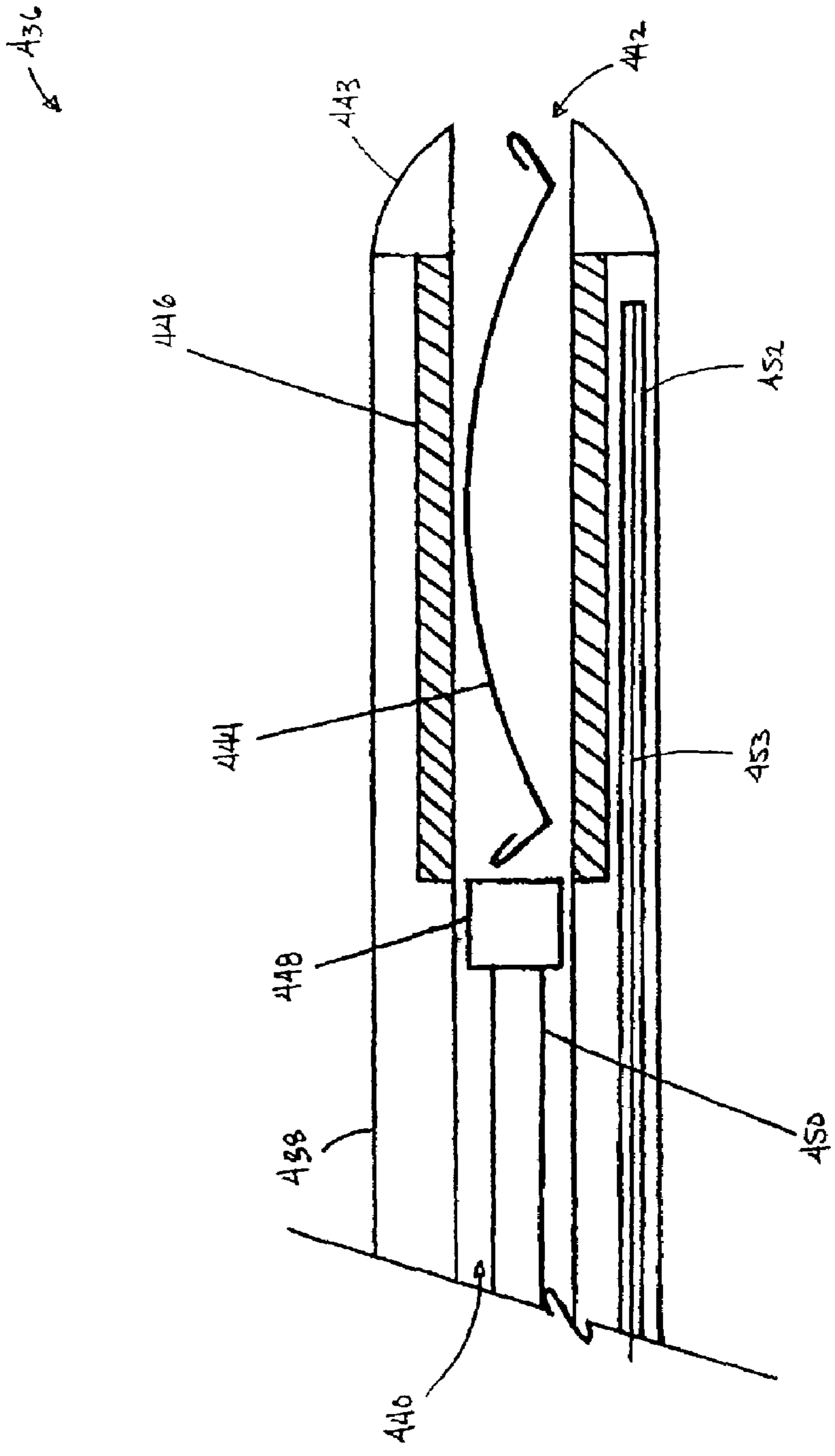

FIG. 37

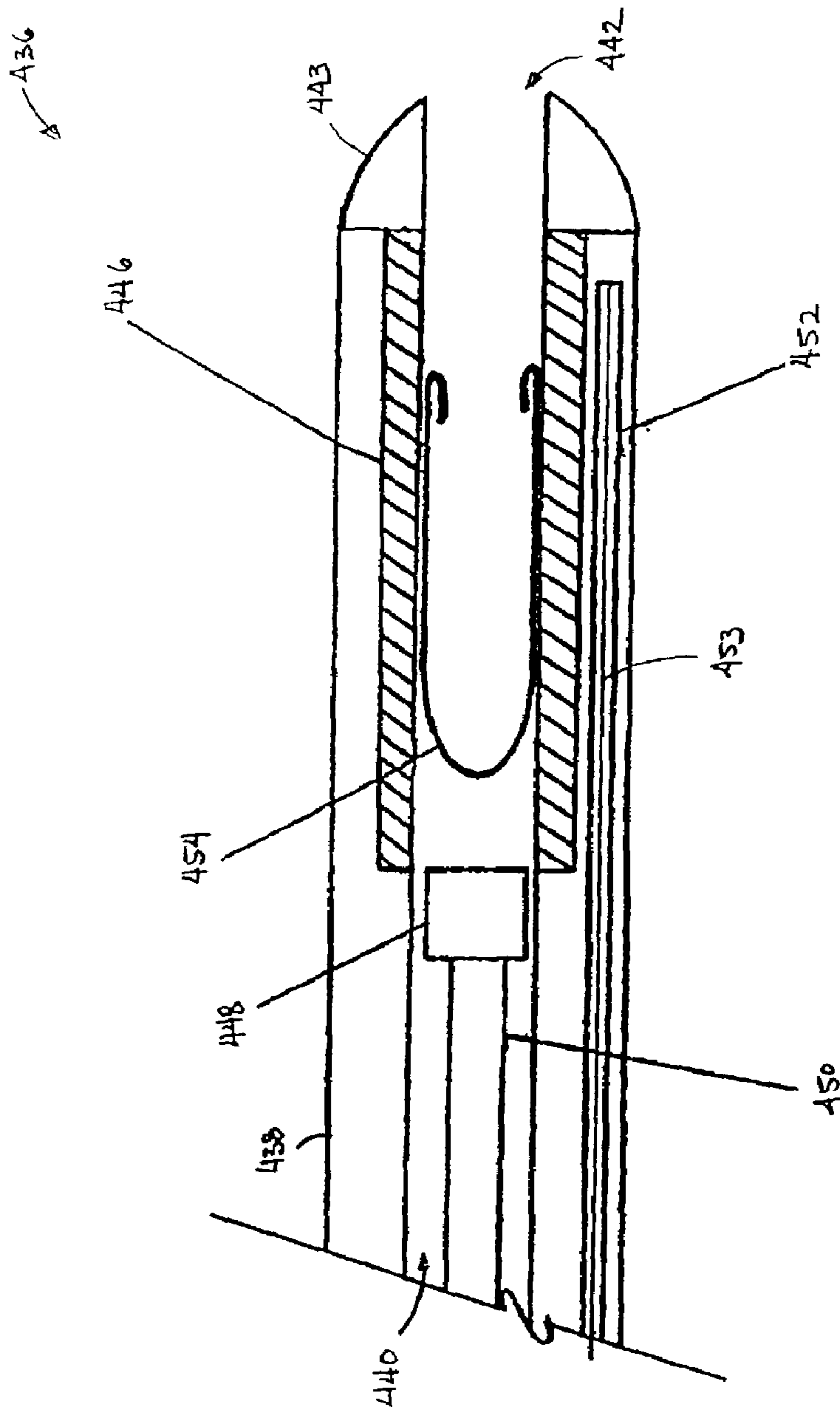

FIG. 38

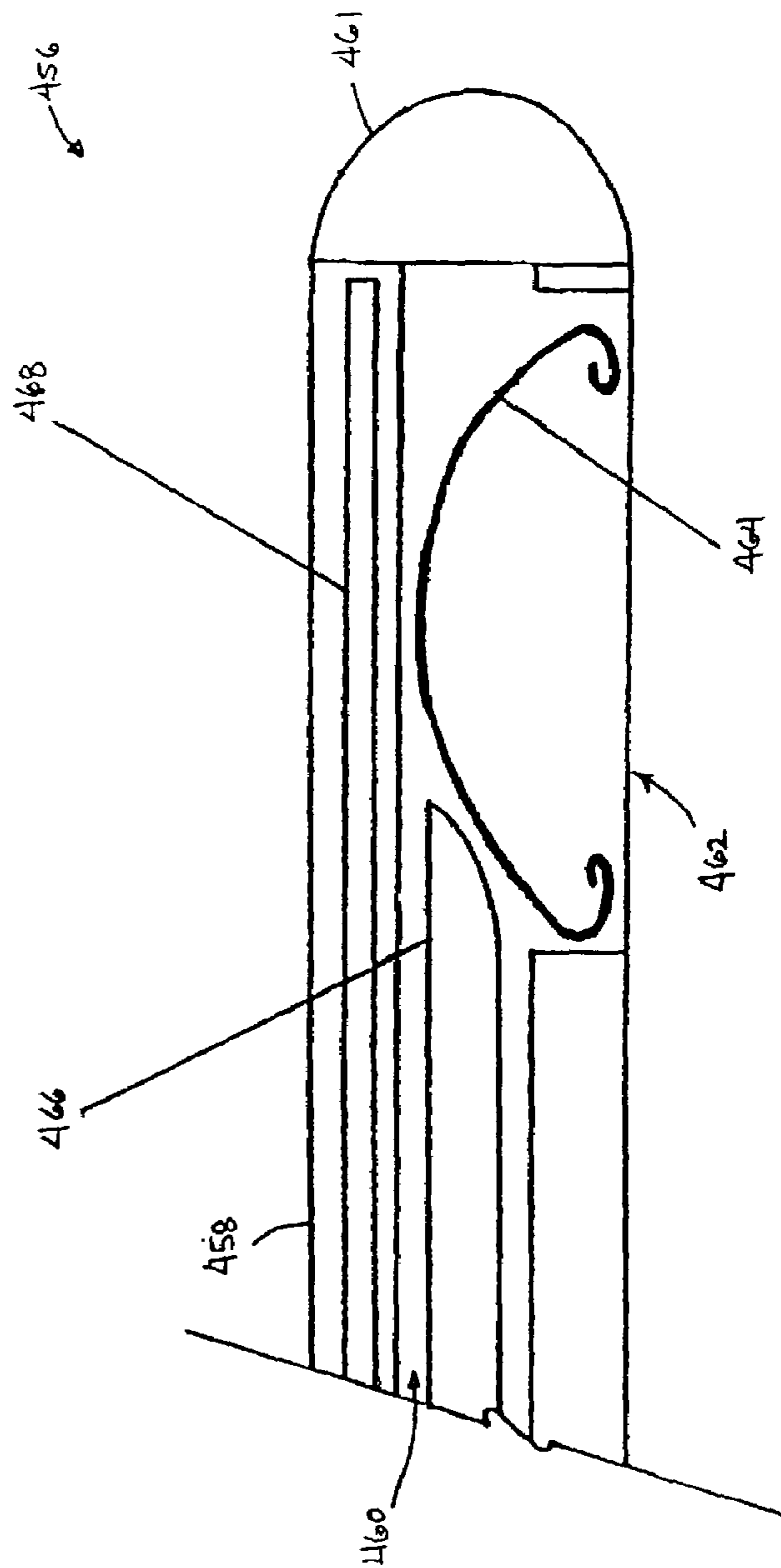

FIG. 39

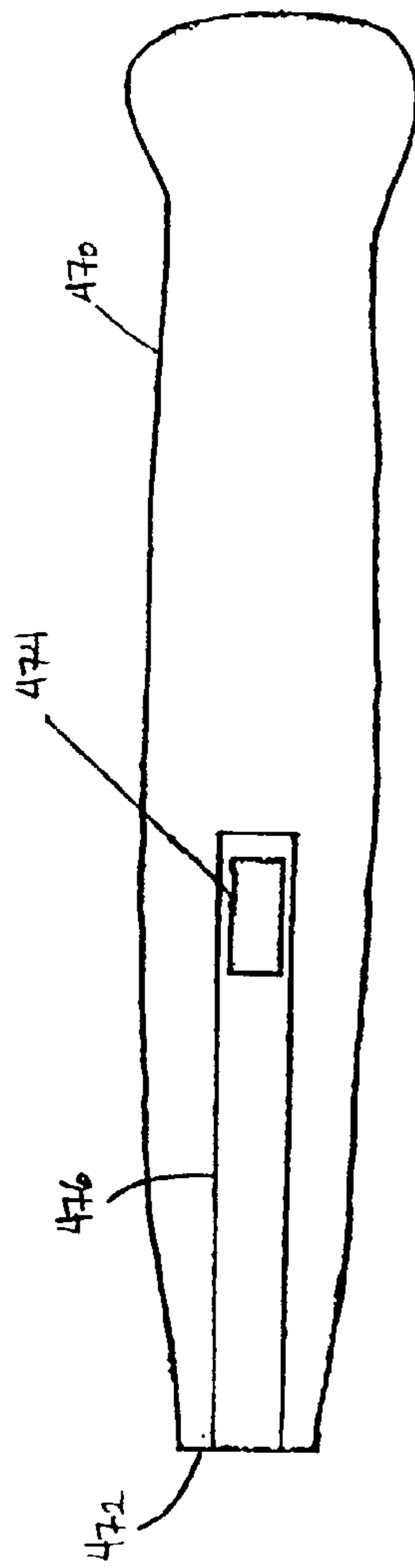

FIG. 40A

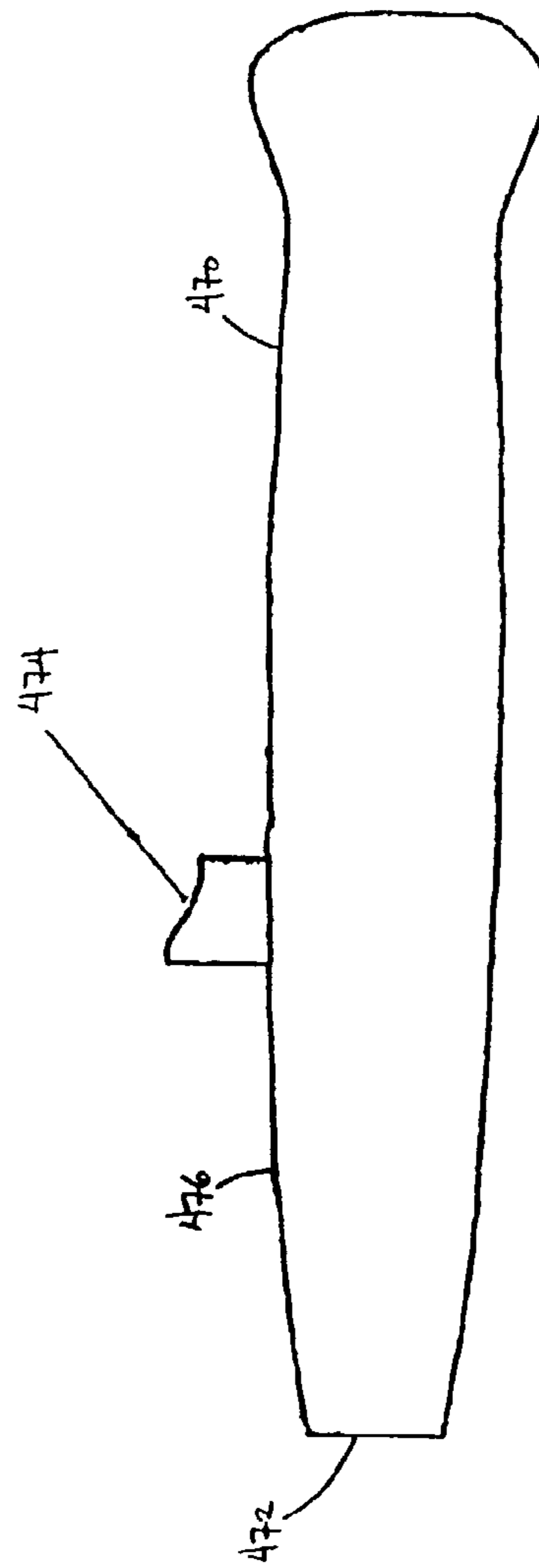

FIG. 40B

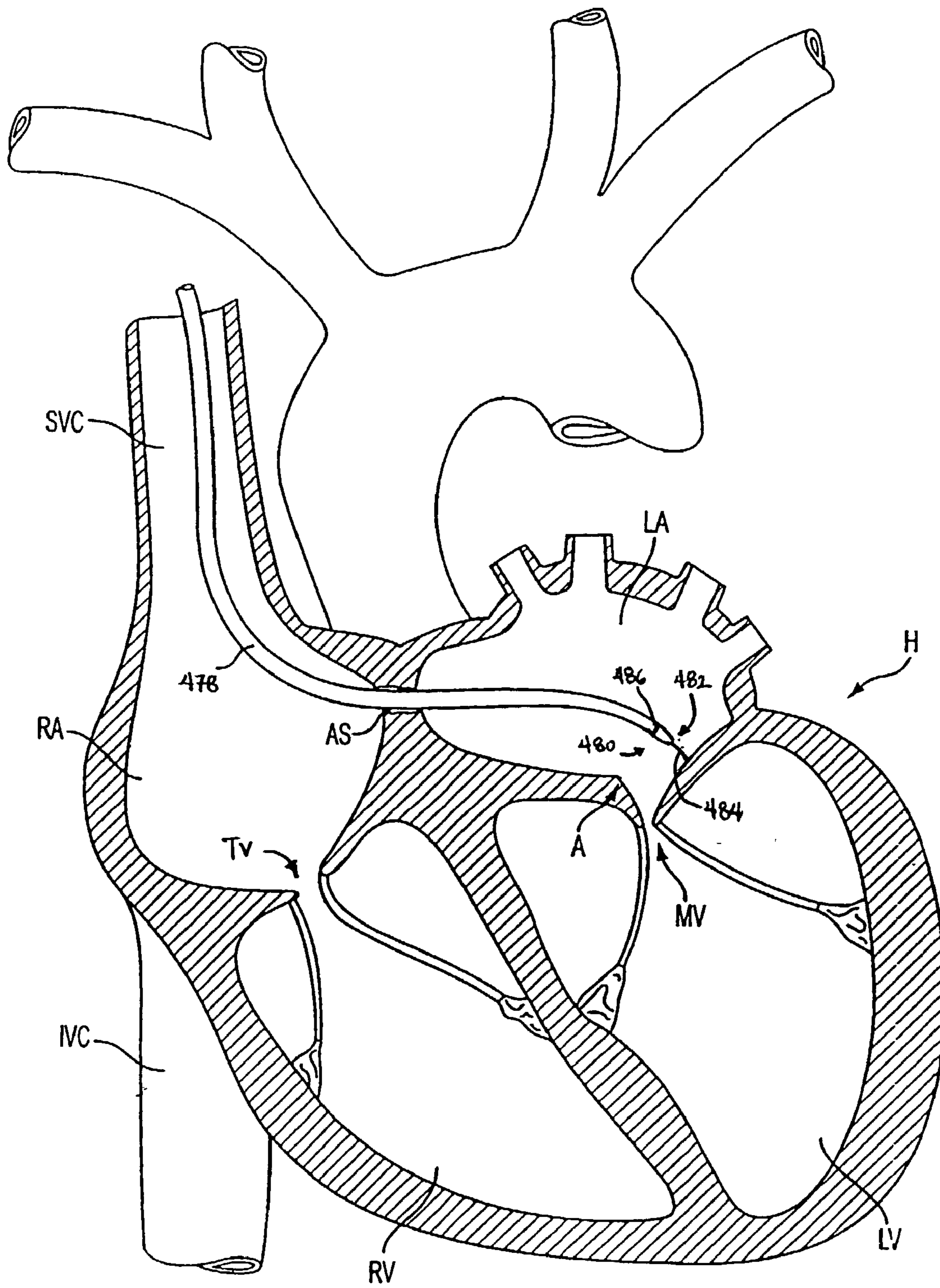

FIG. 41A

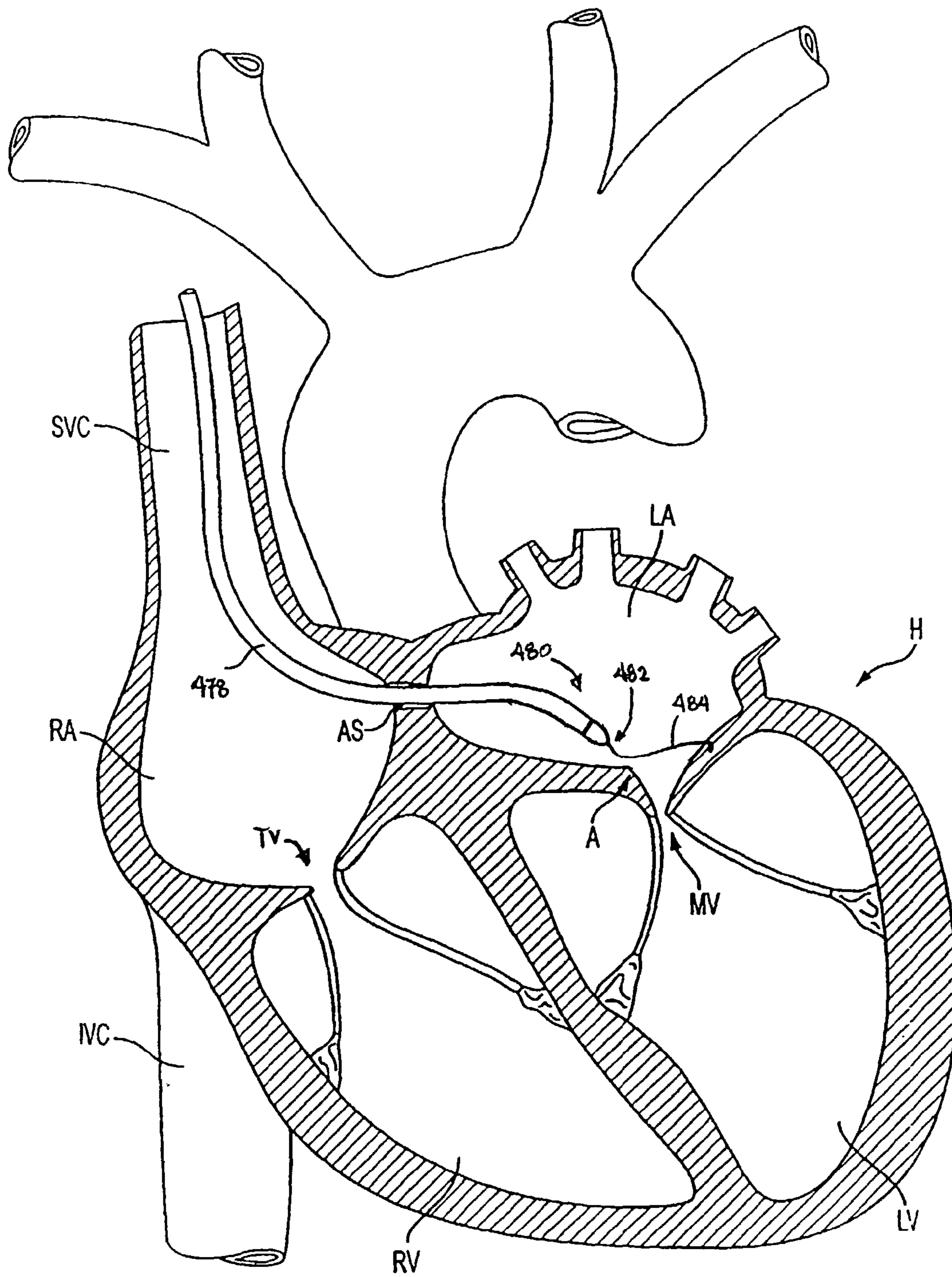

FIG. 41B

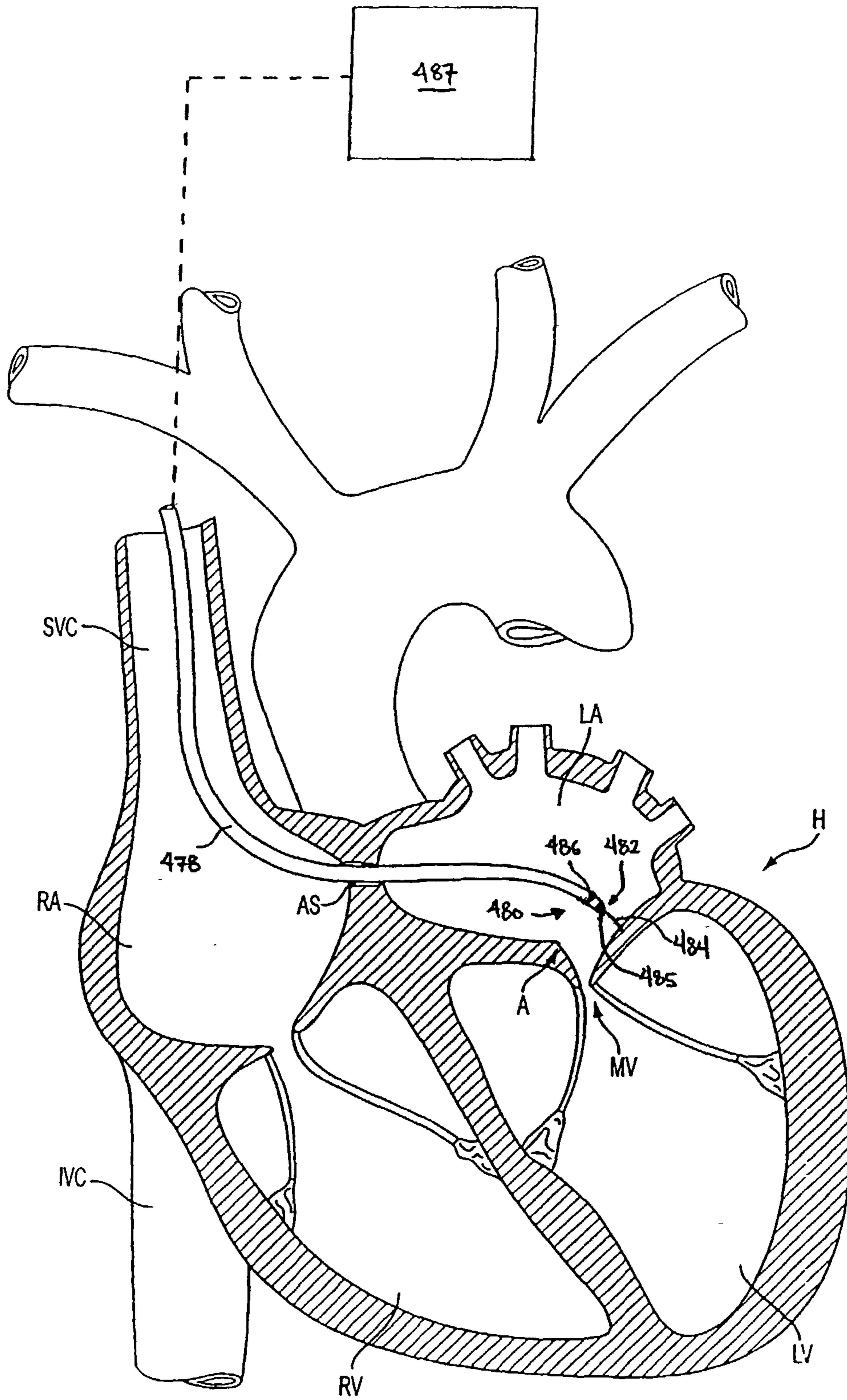

FIG. 41C

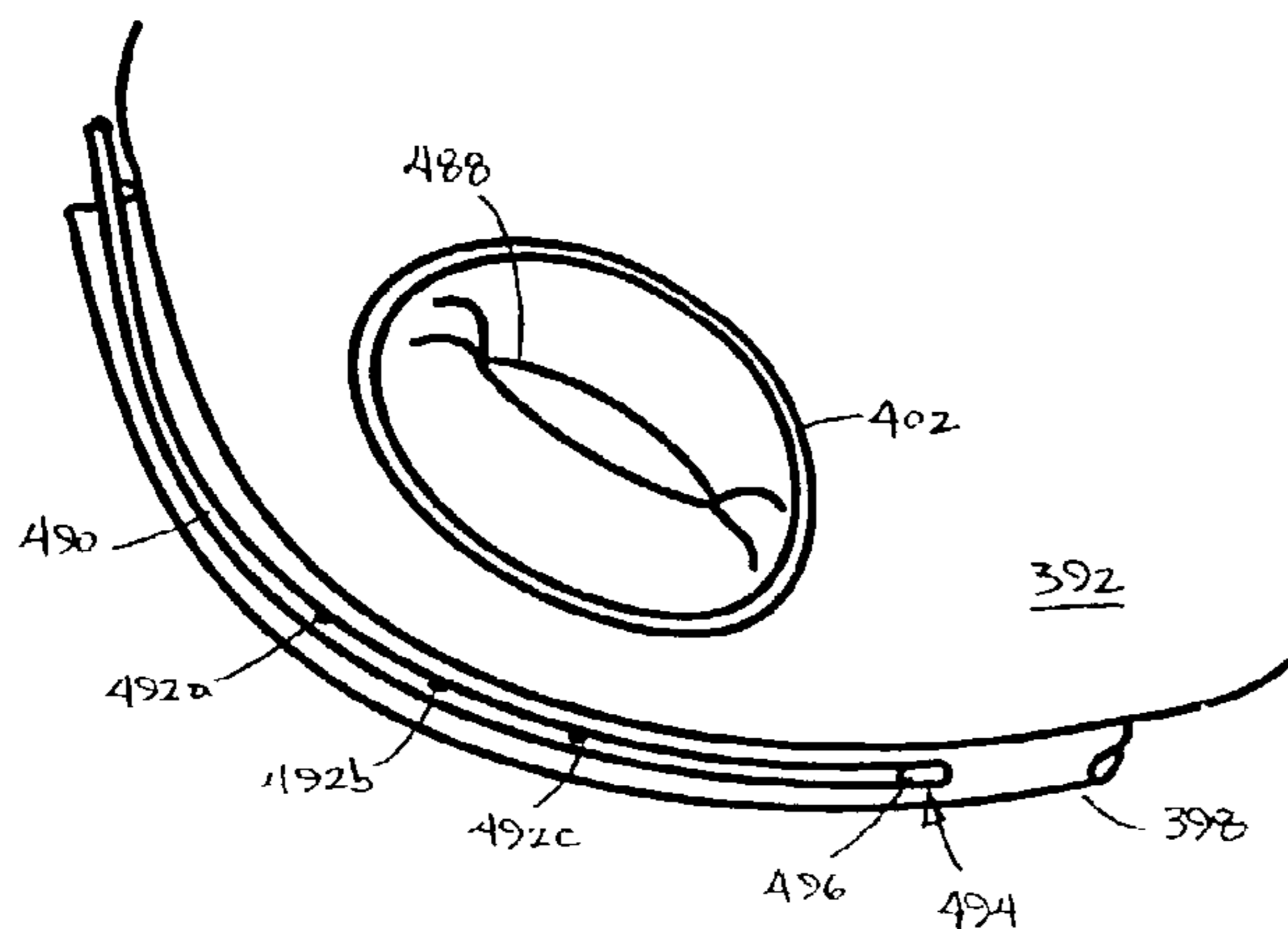

FIG. 42 A

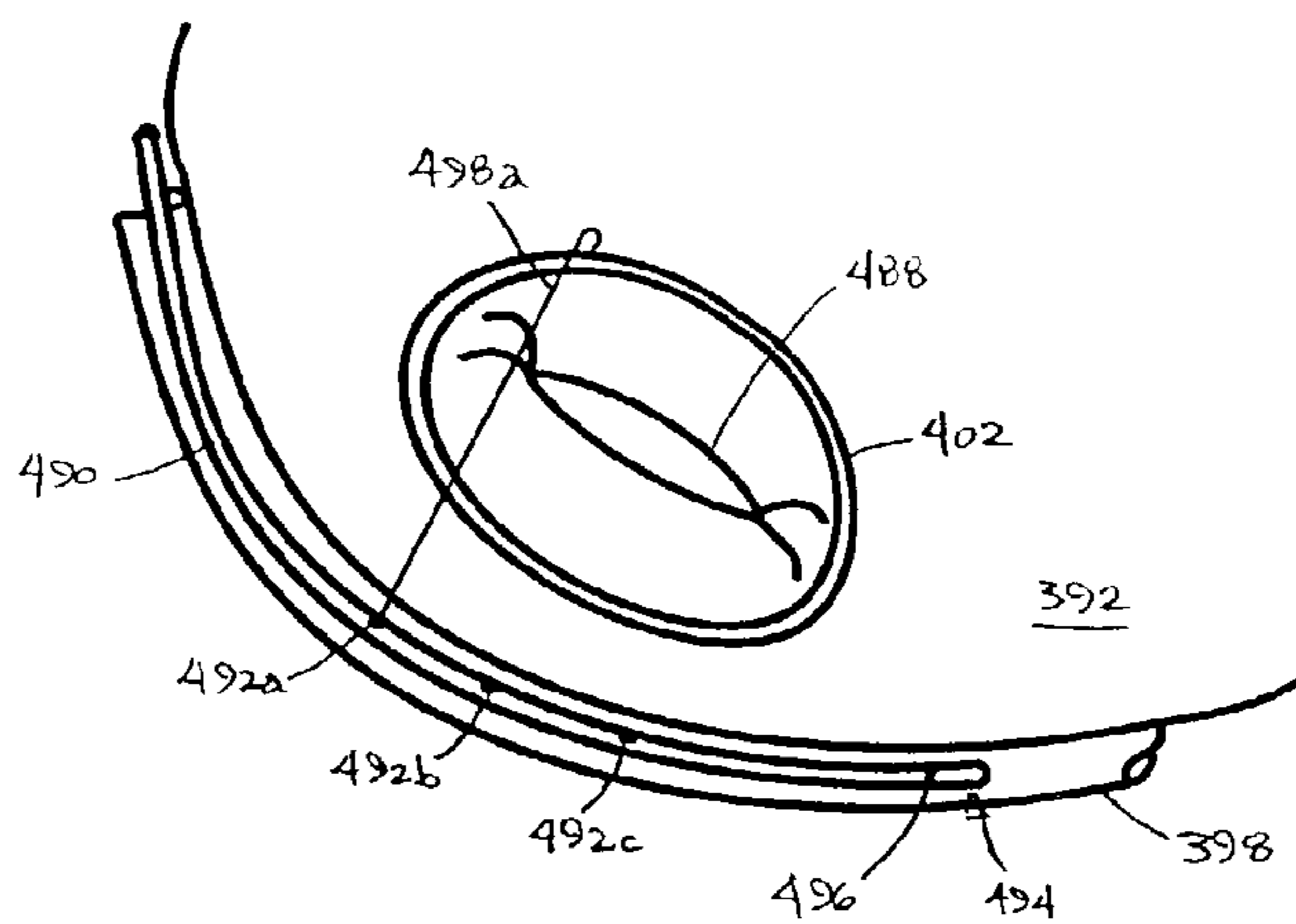

FIG. 42 B

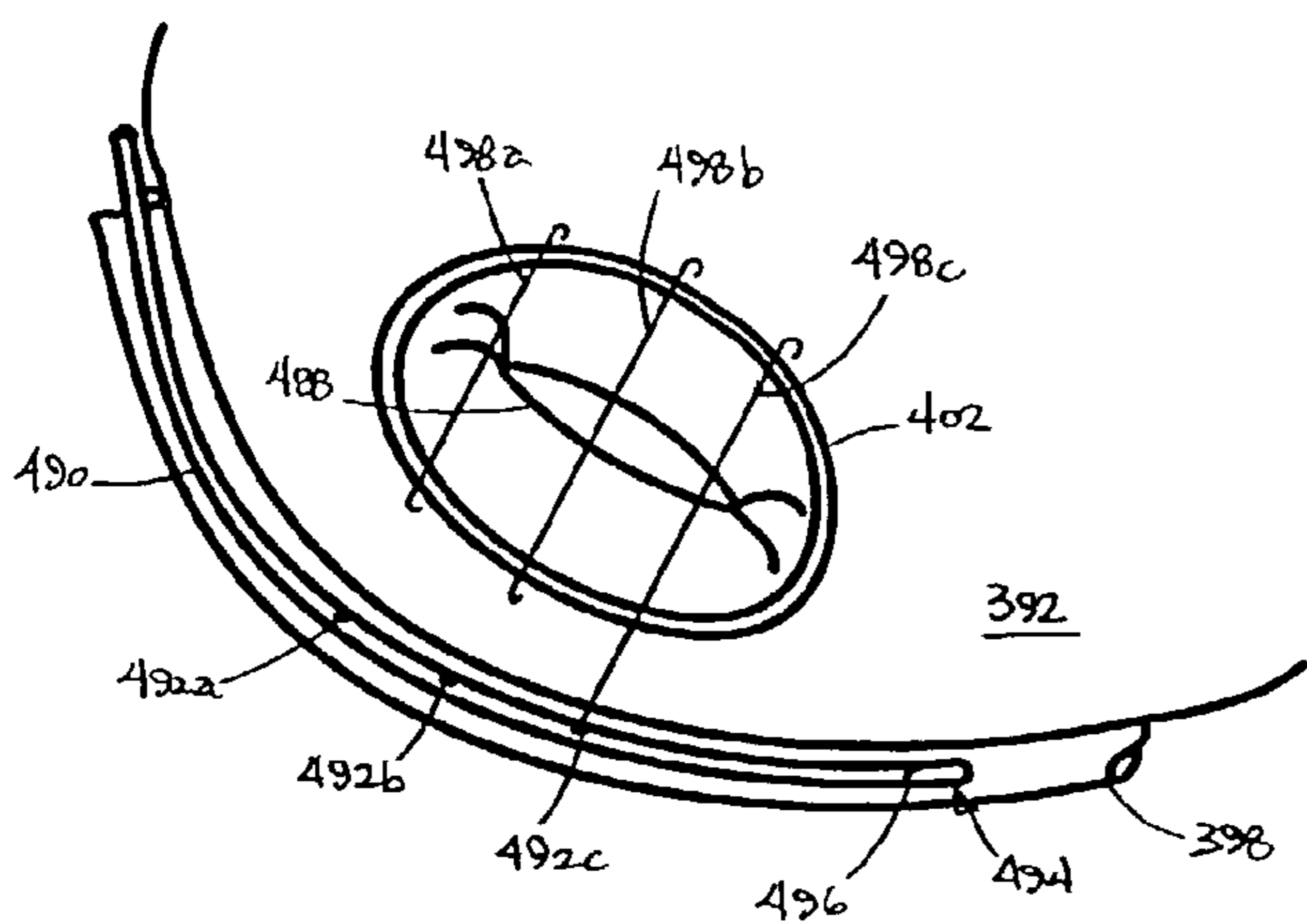

FIG. 42 C

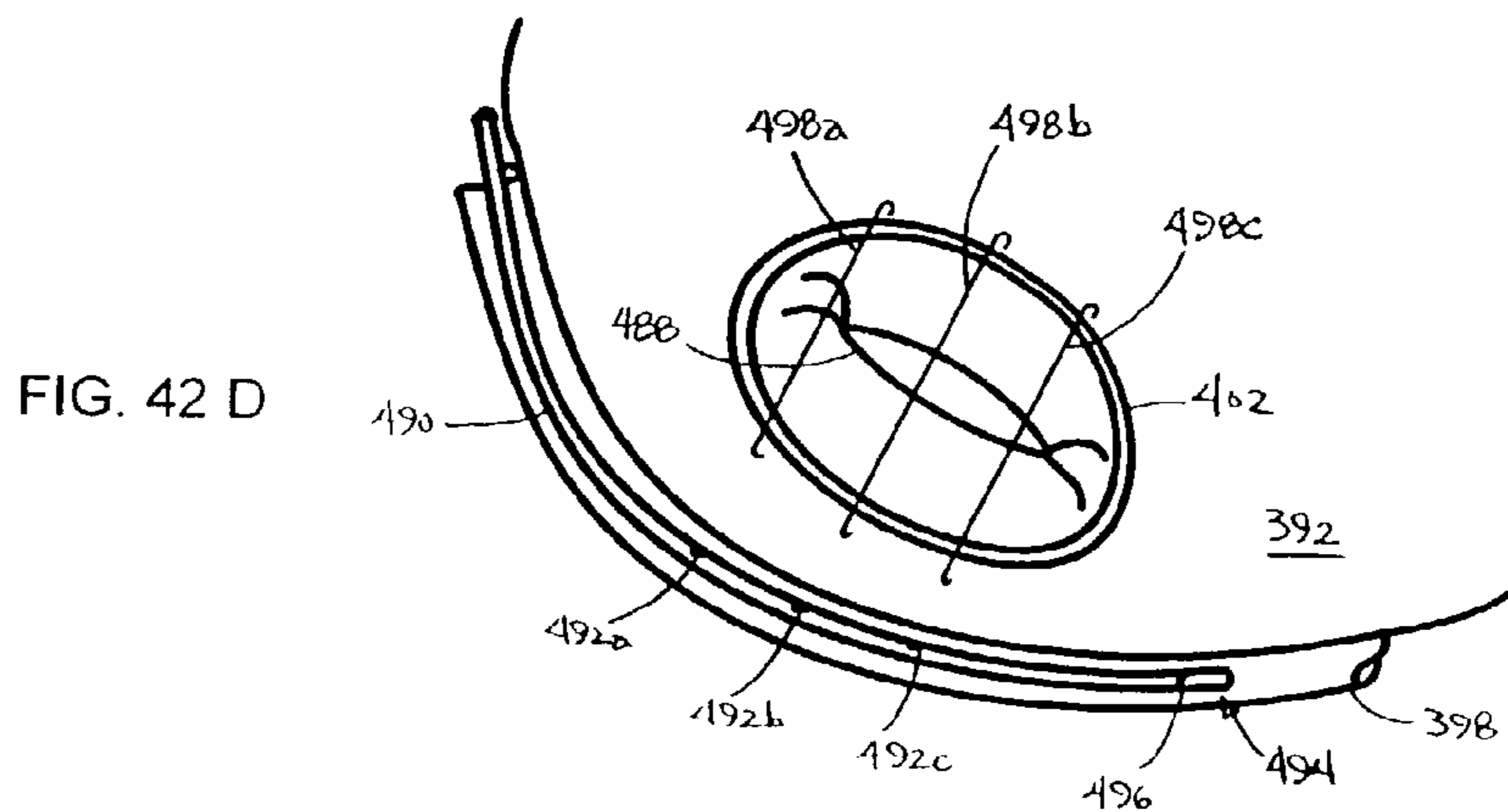

FIG. 42 D

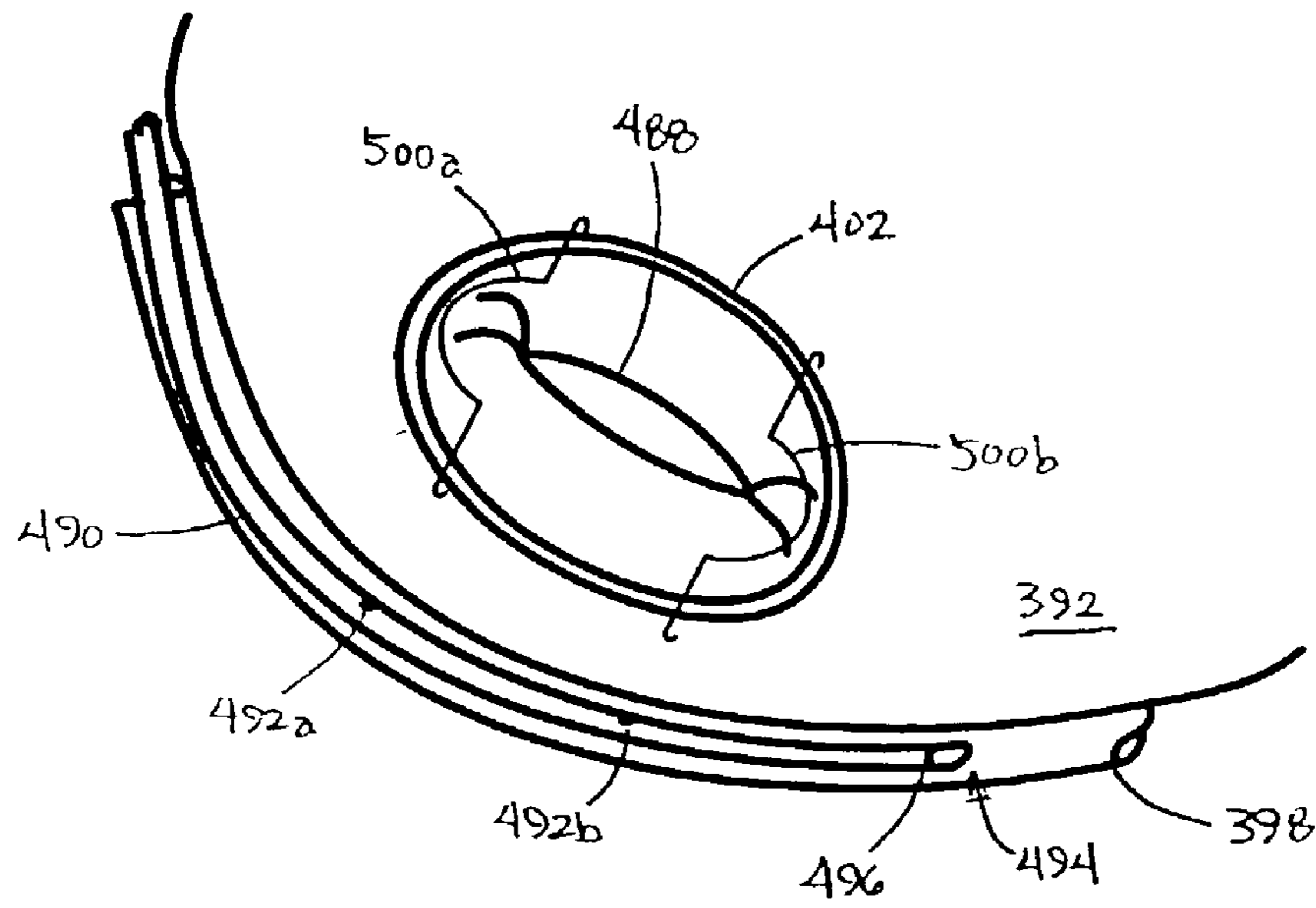

FIG. 43 A

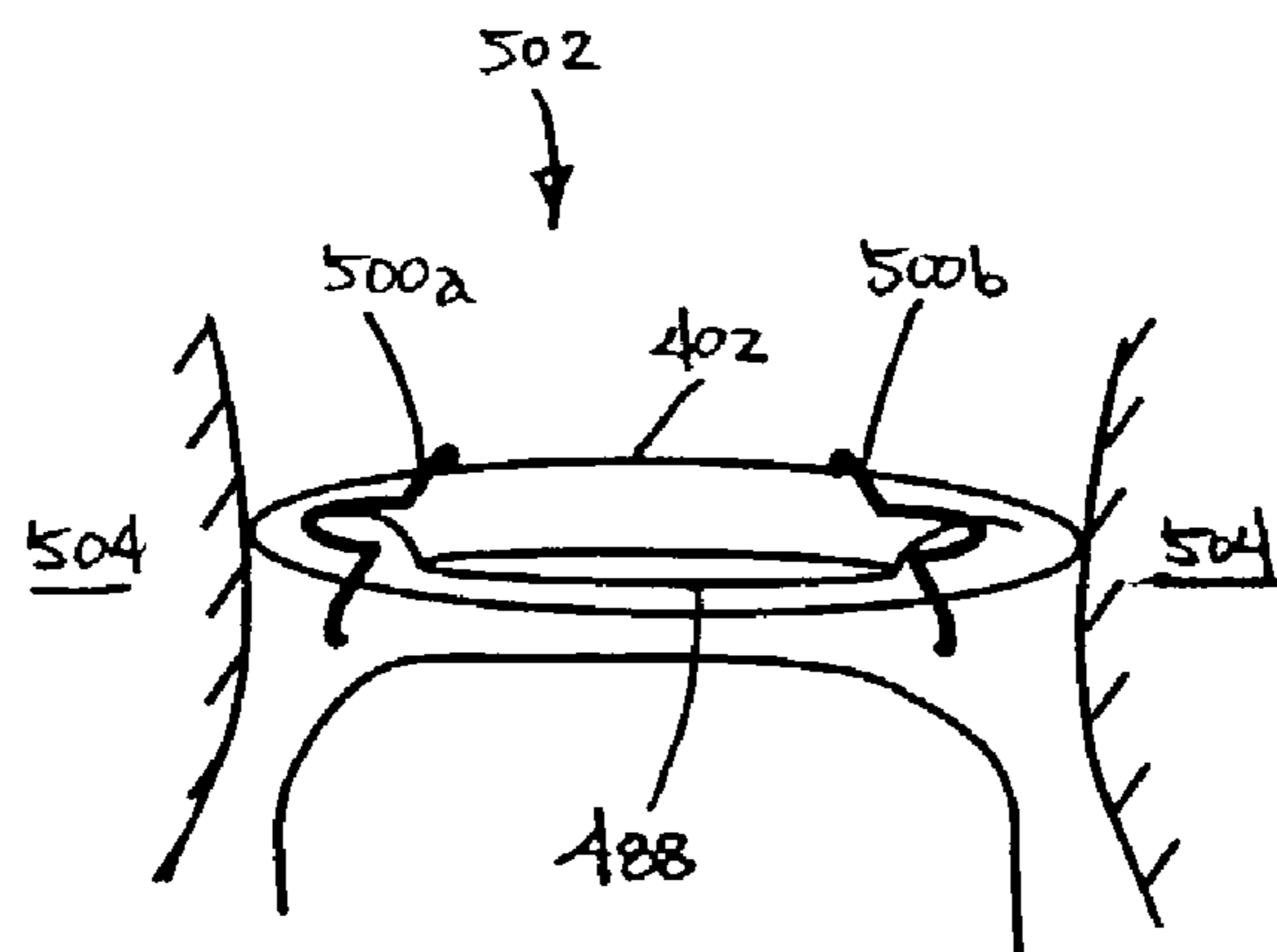

FIG. 43 B

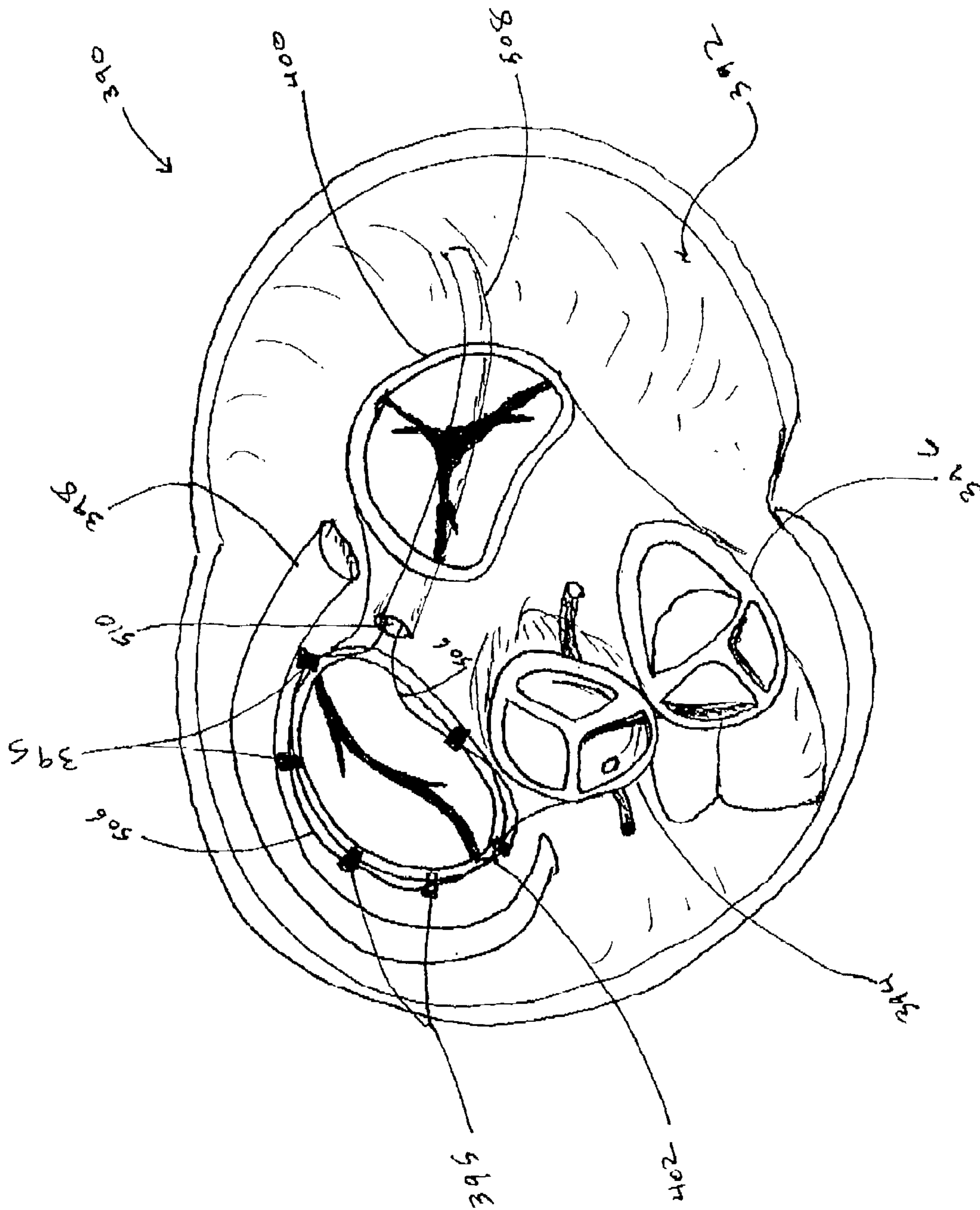

FIG. 44A

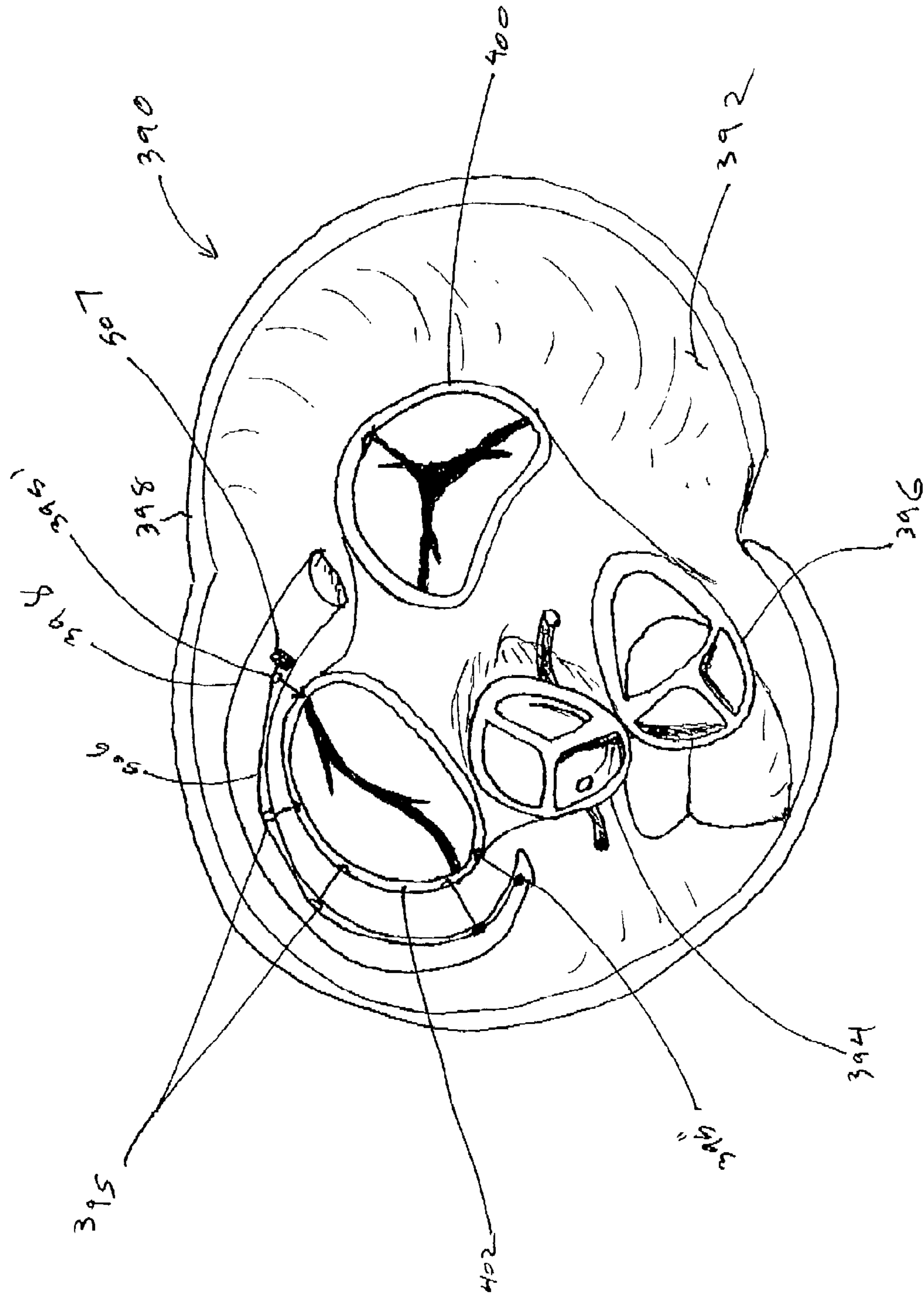

FIG. 45

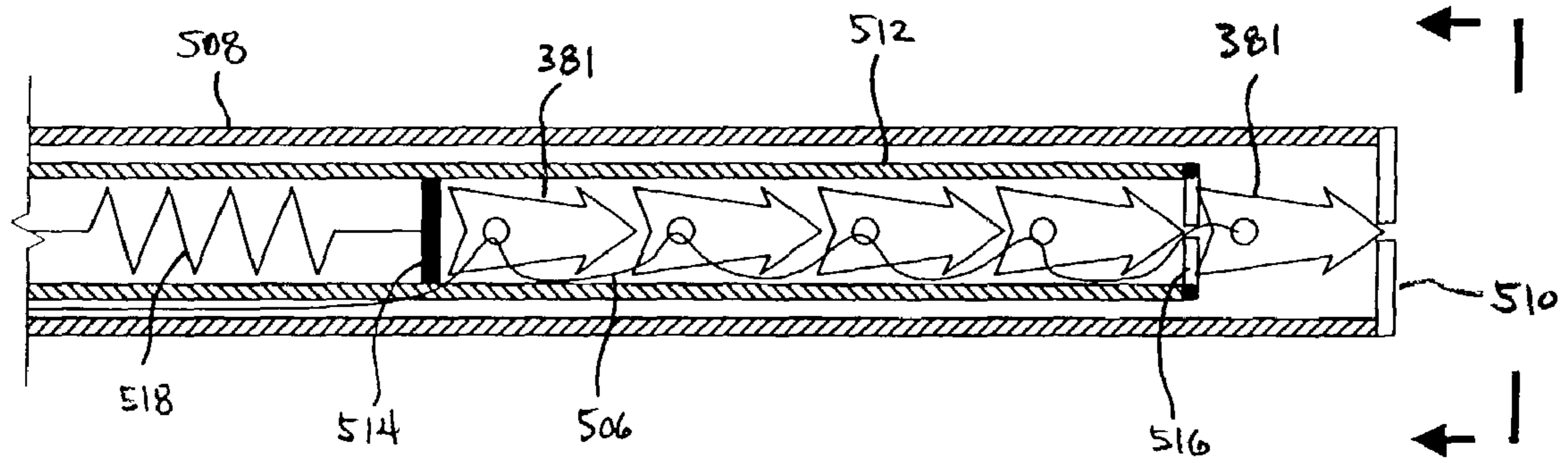

FIG. 46A

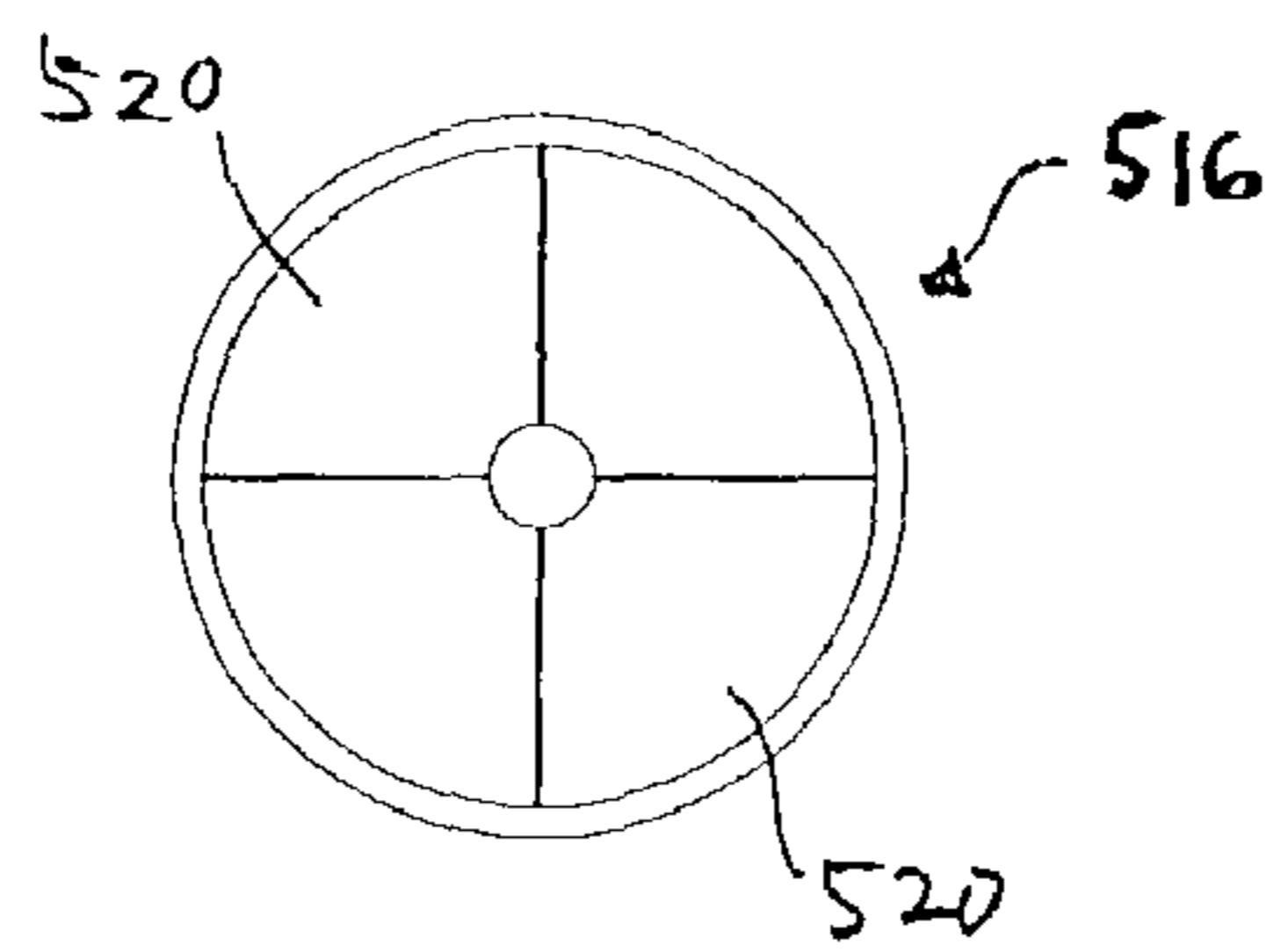

FIG. 46B

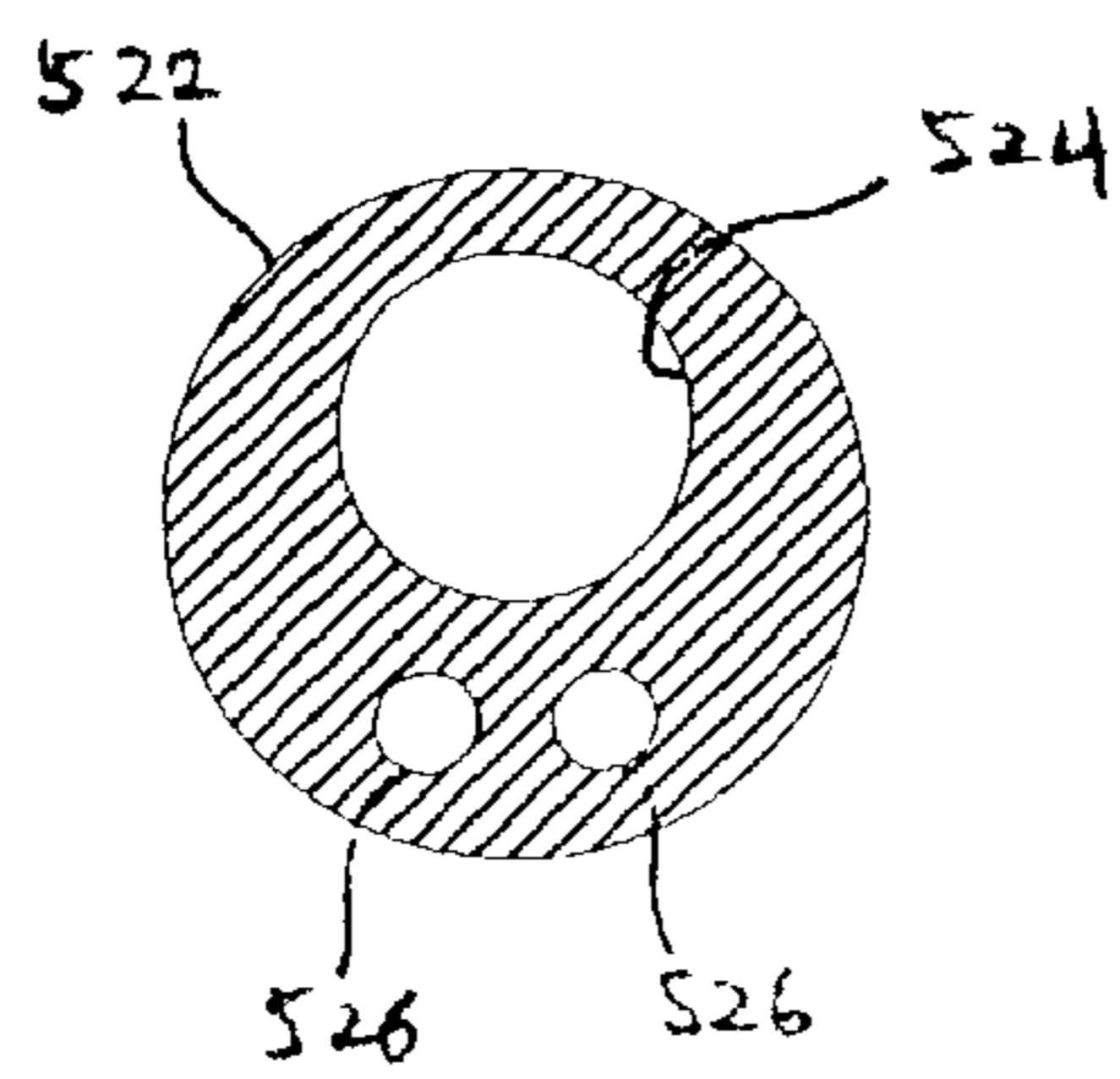

FIG. 46C

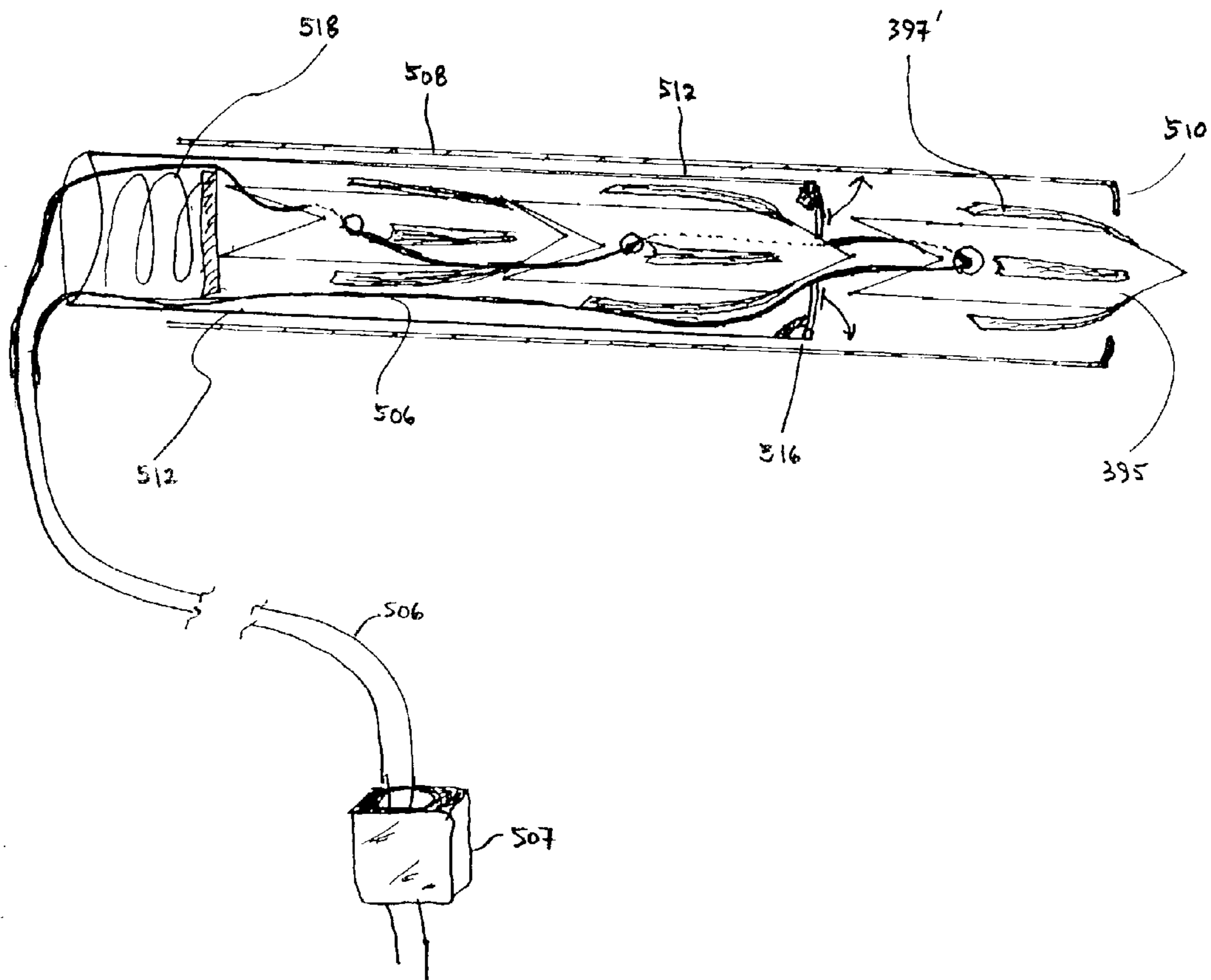

FIG. 47

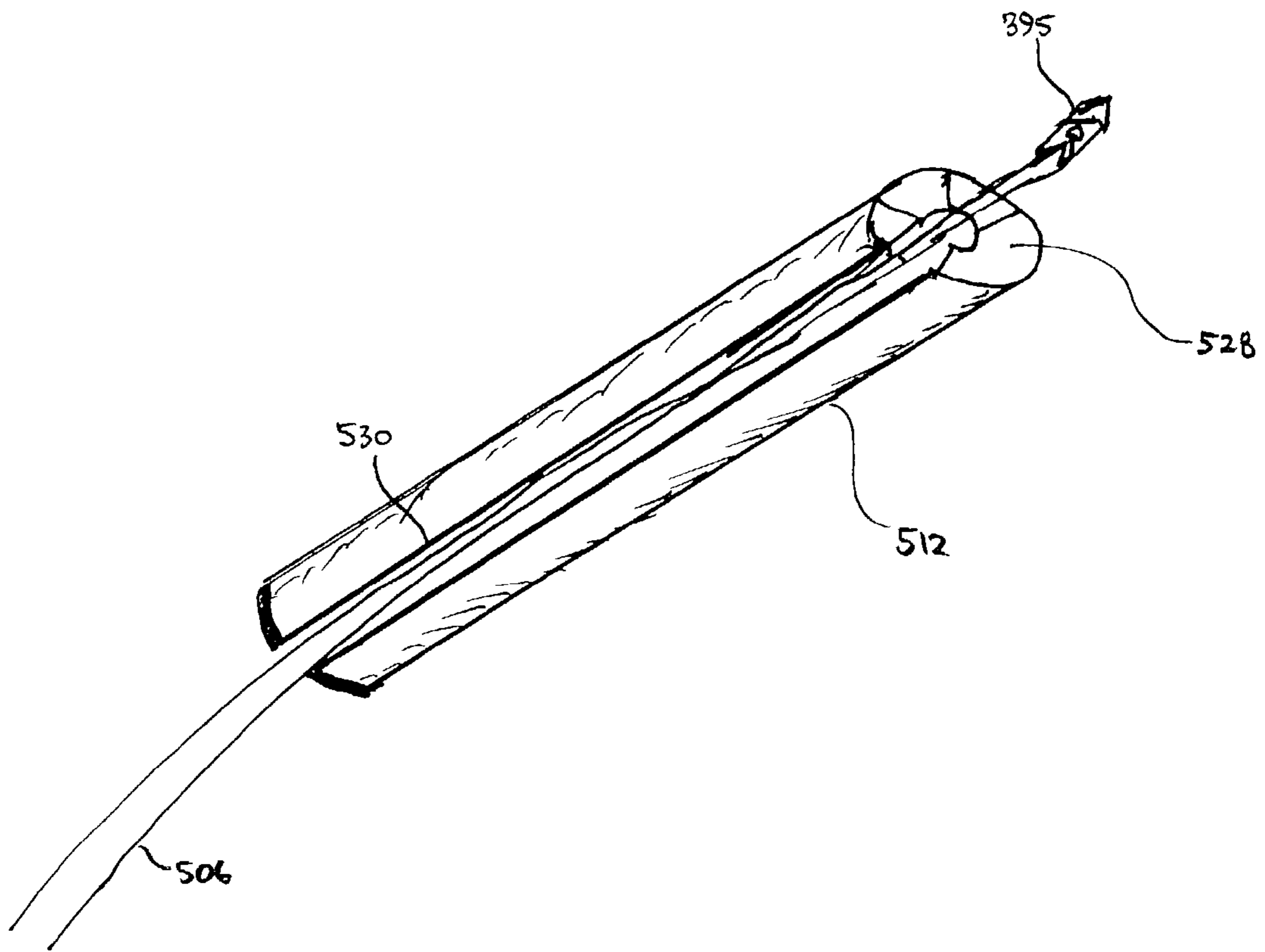

FIG. 48

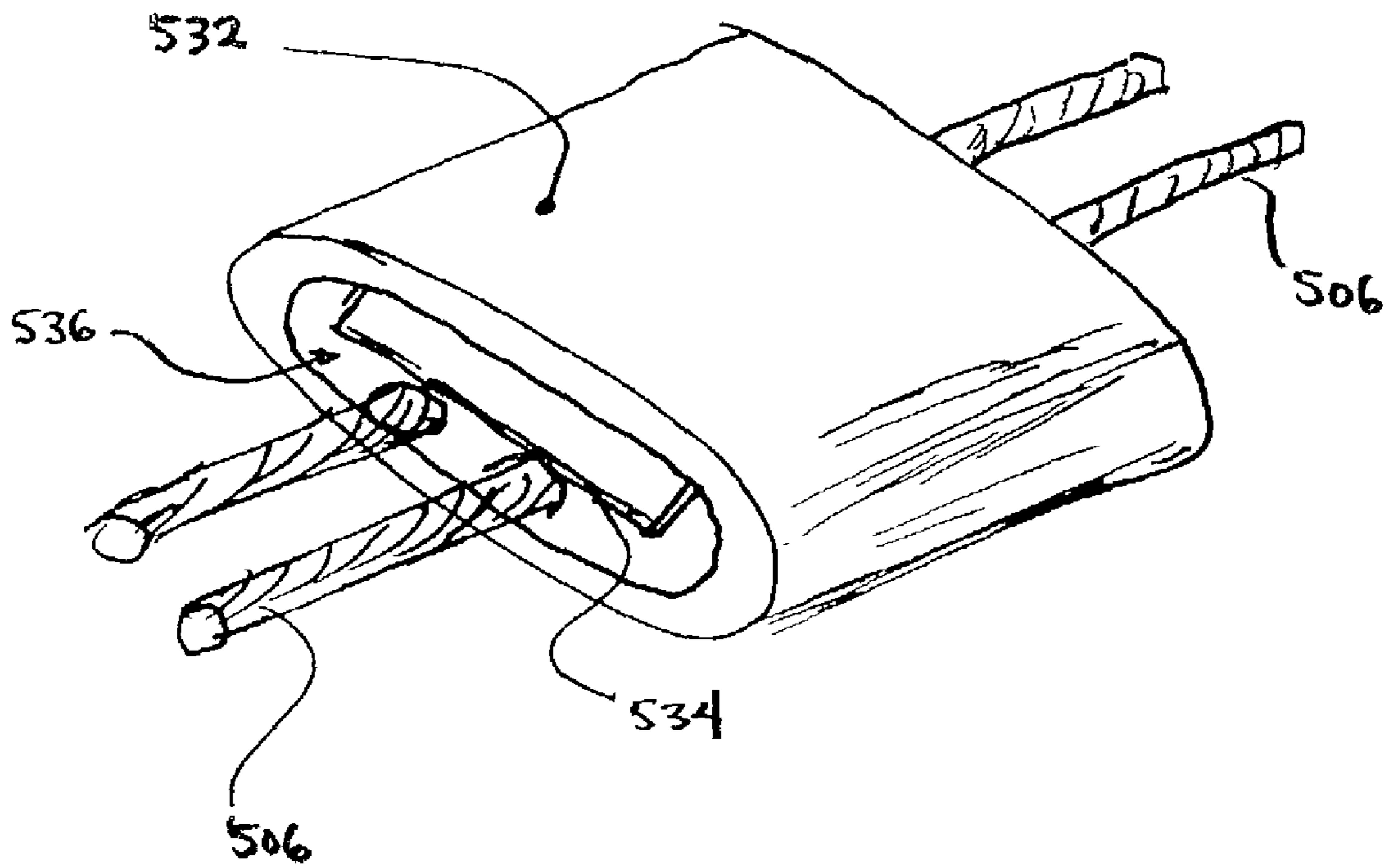

FIG. 49A

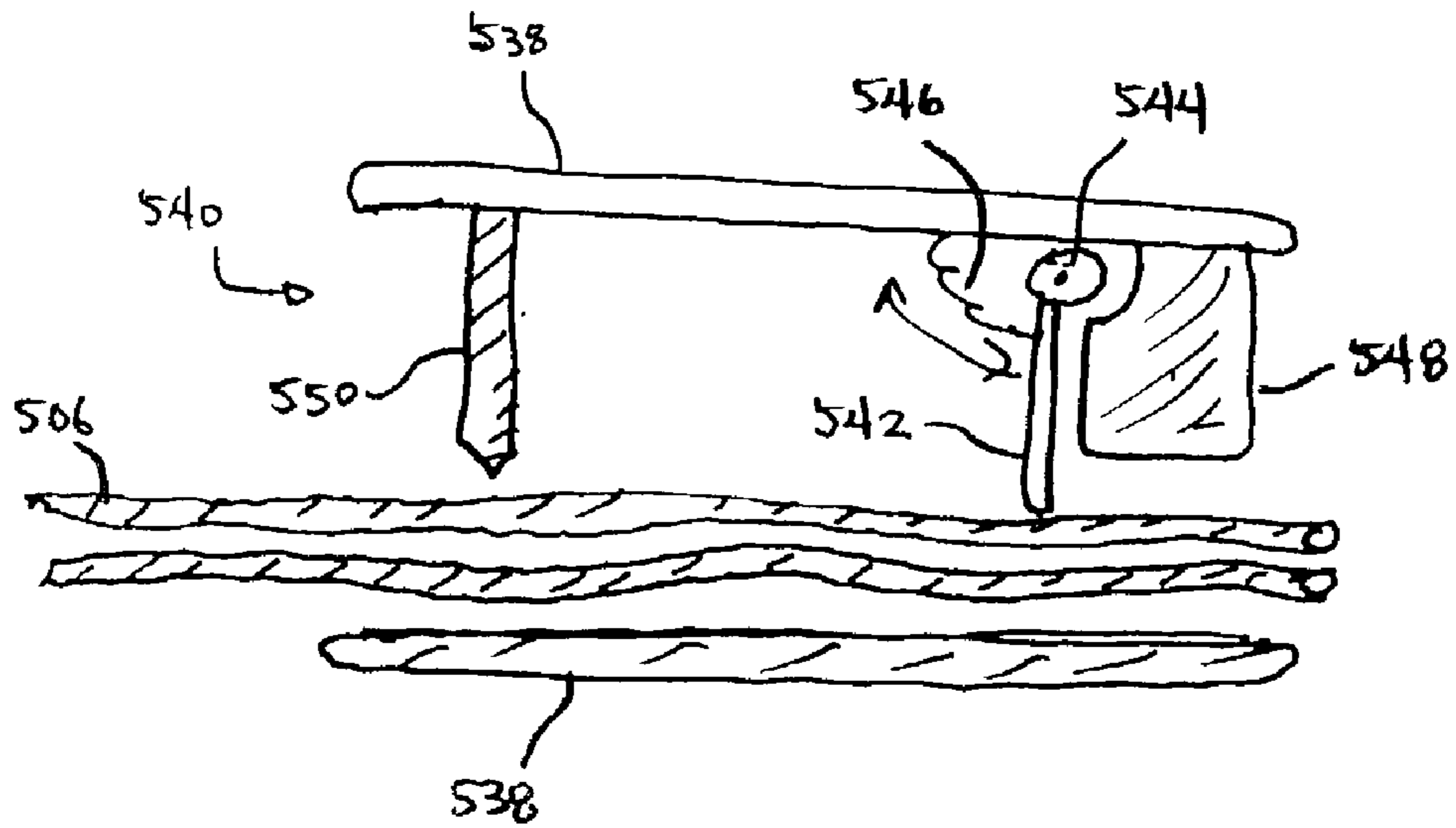

FIG. 49B

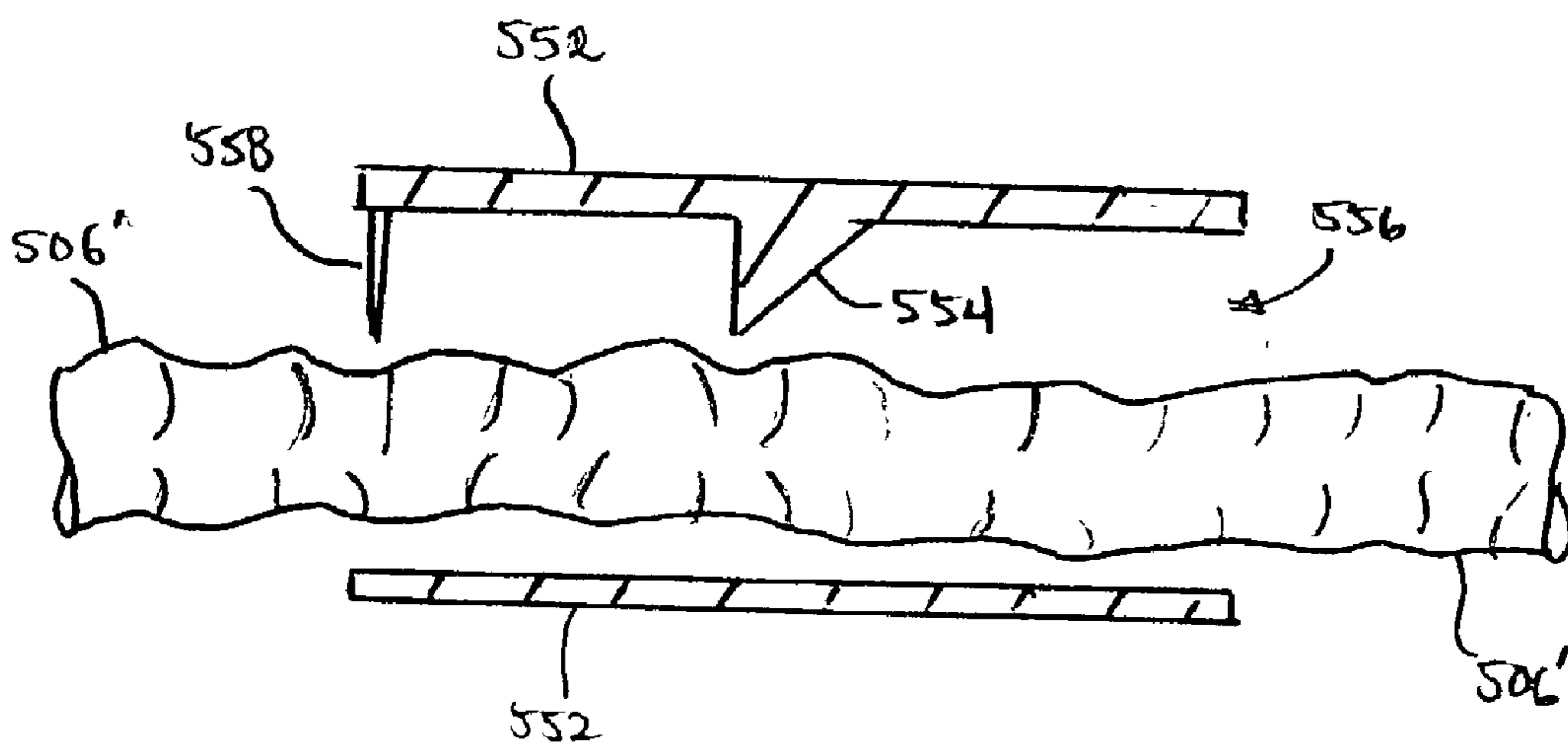

FIG. 49C

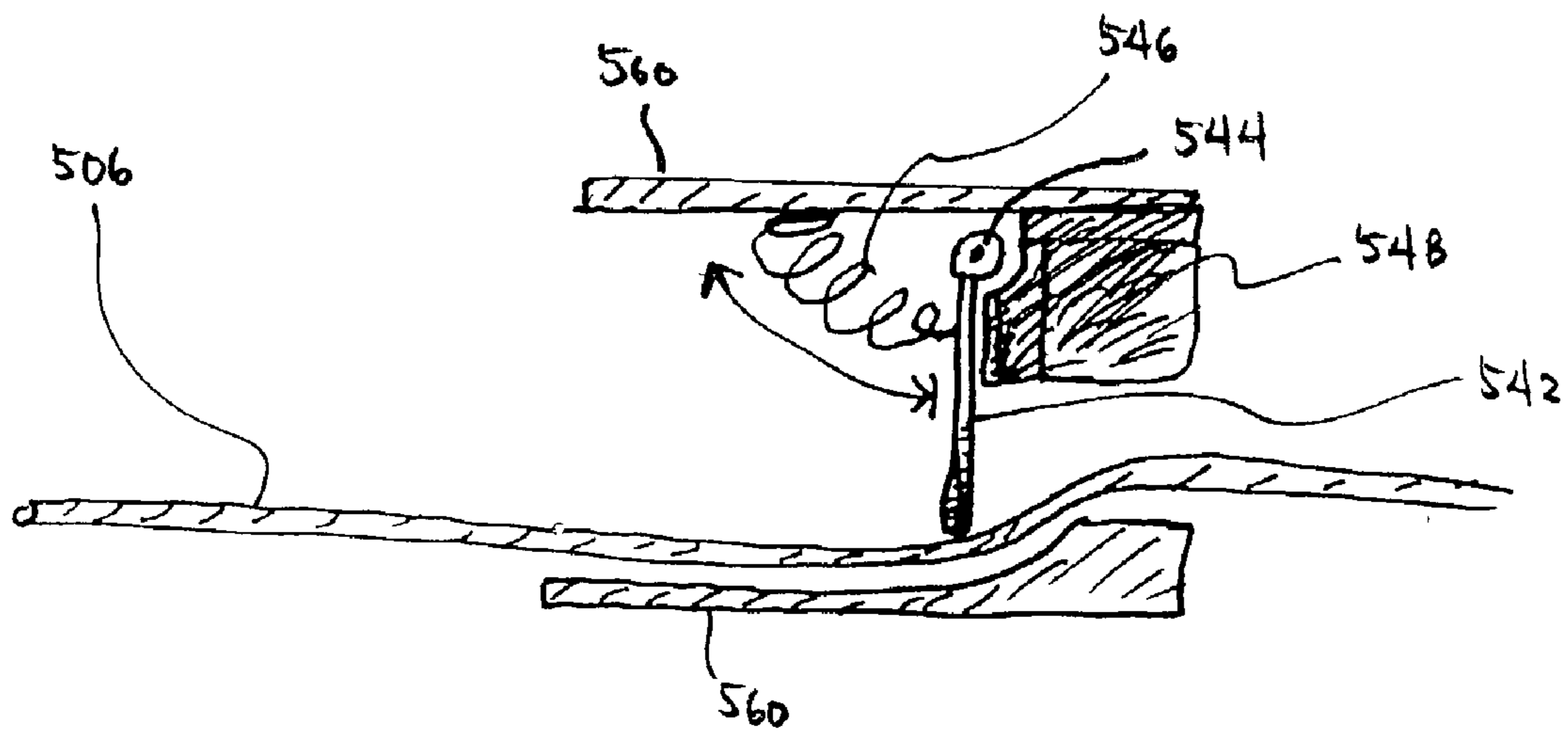

FIG. 49D

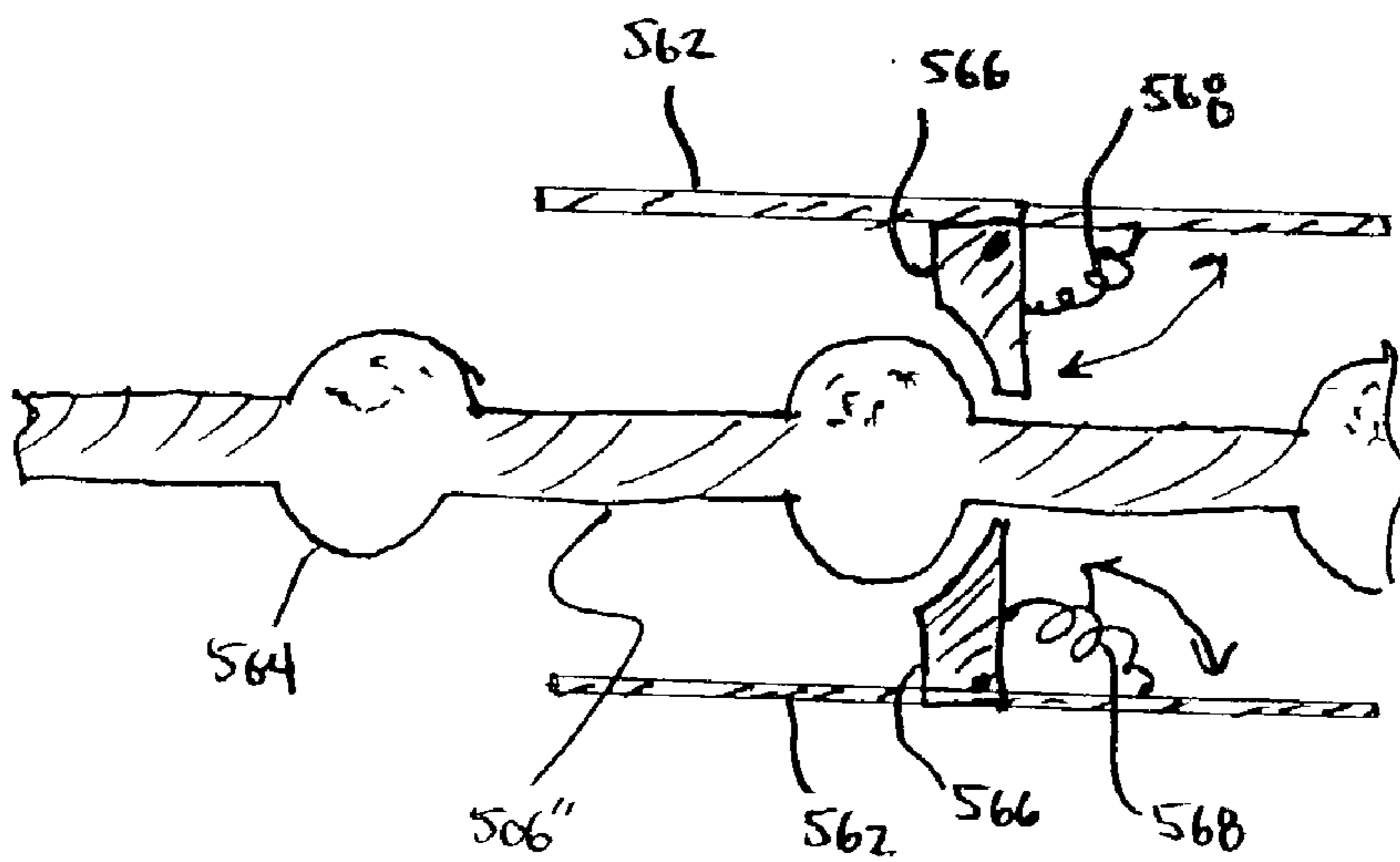

FIG. 49E

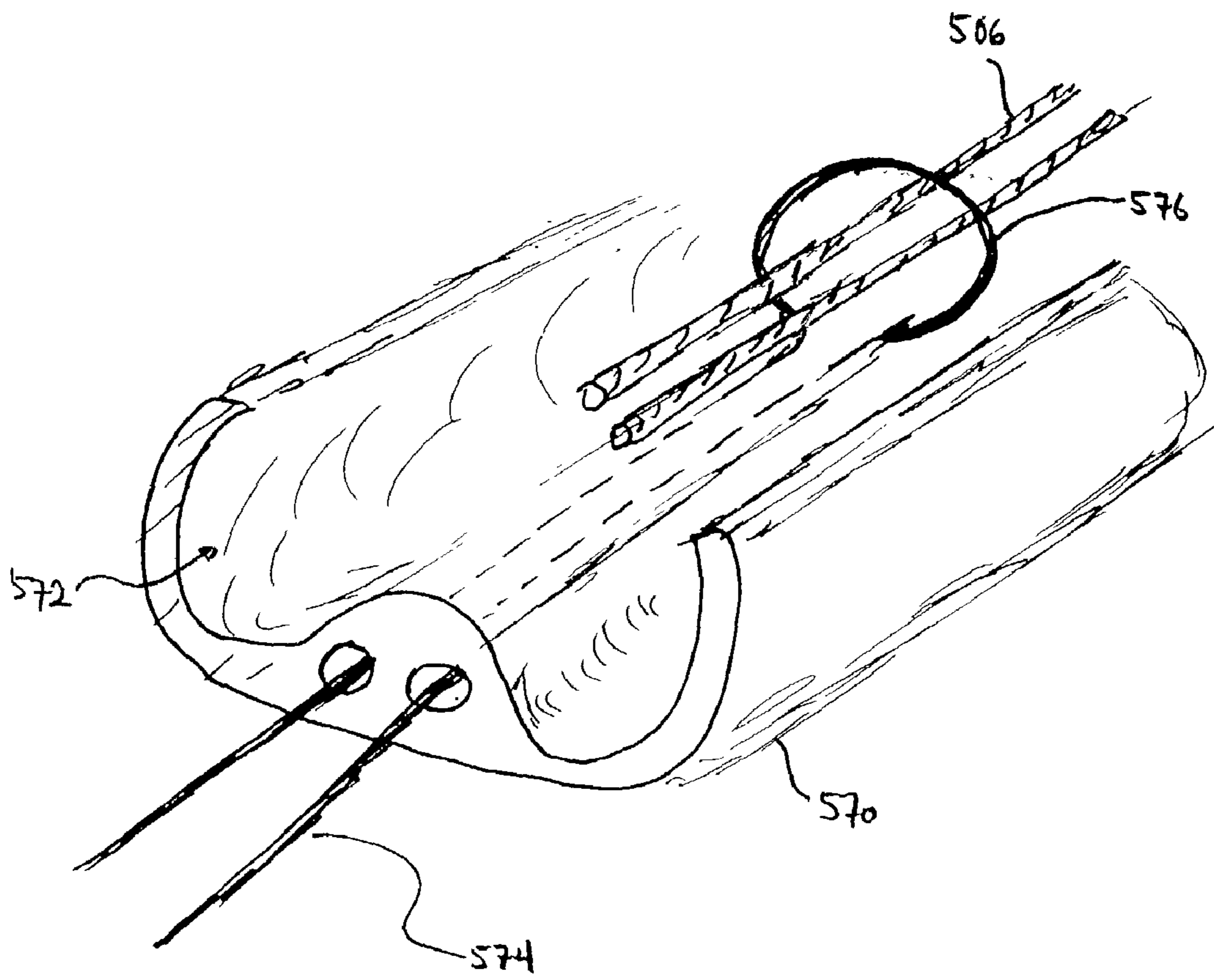

FIG. 50

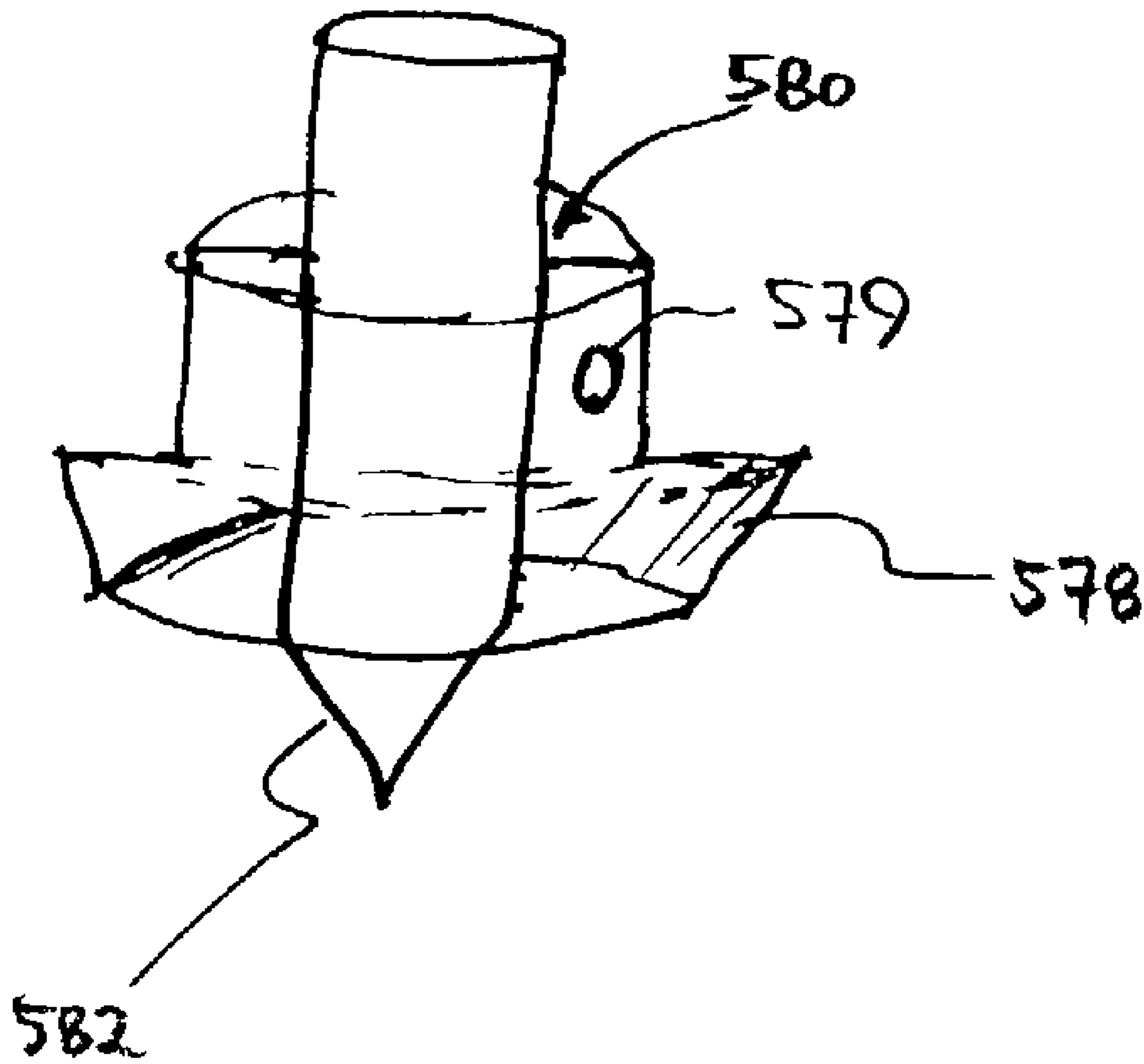

FIG. 51

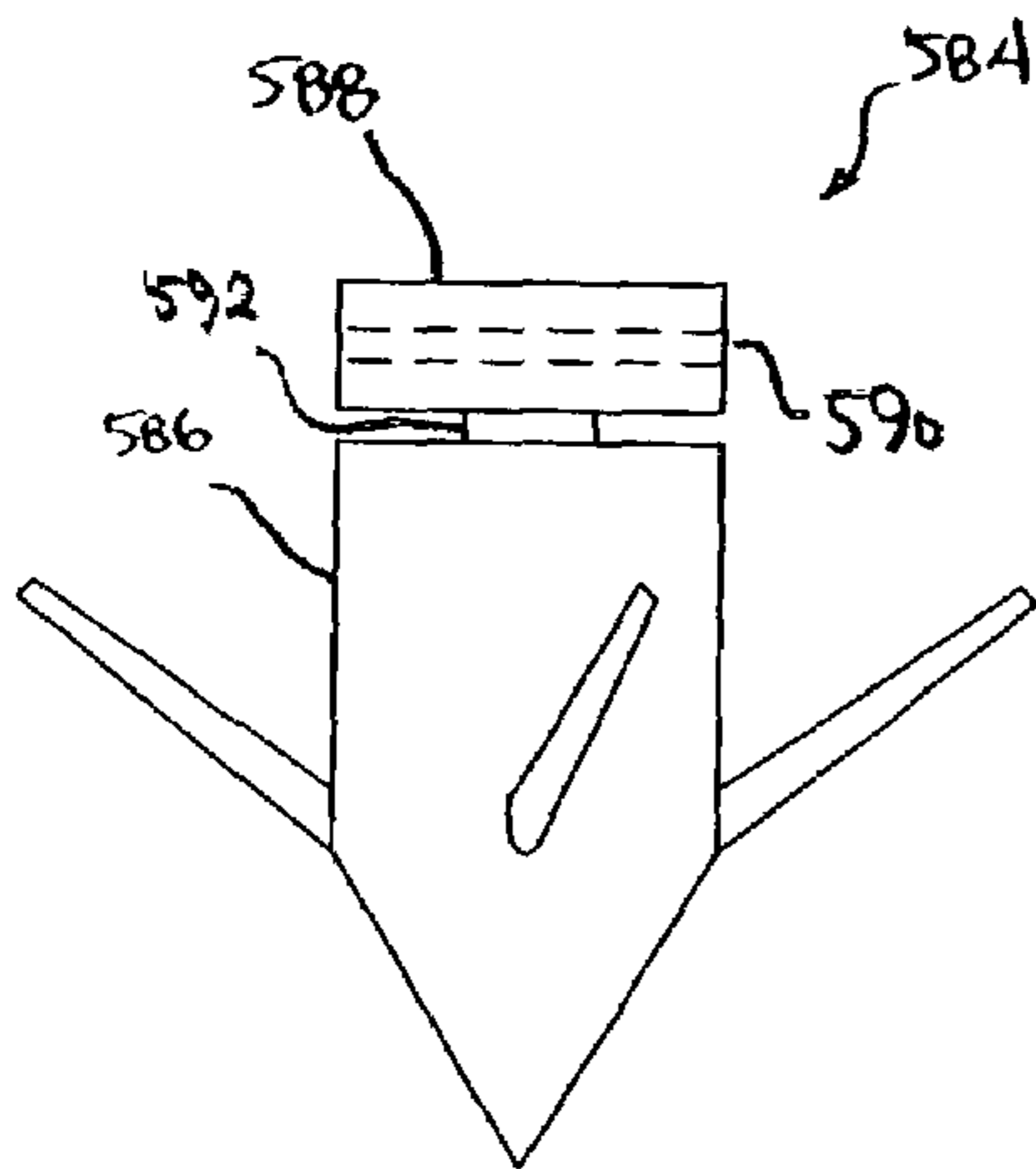

FIG. 52A

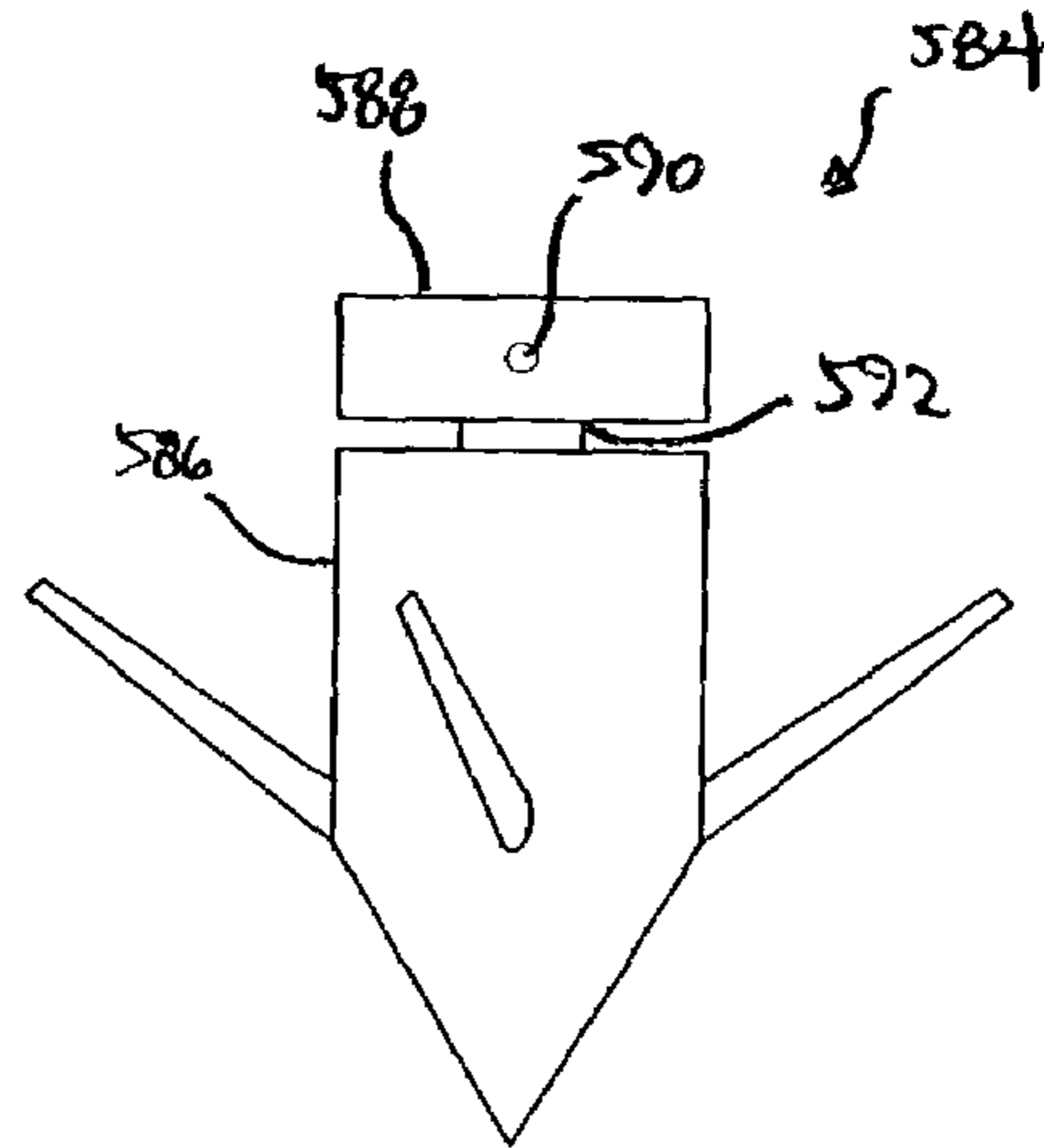

FIG. 52B

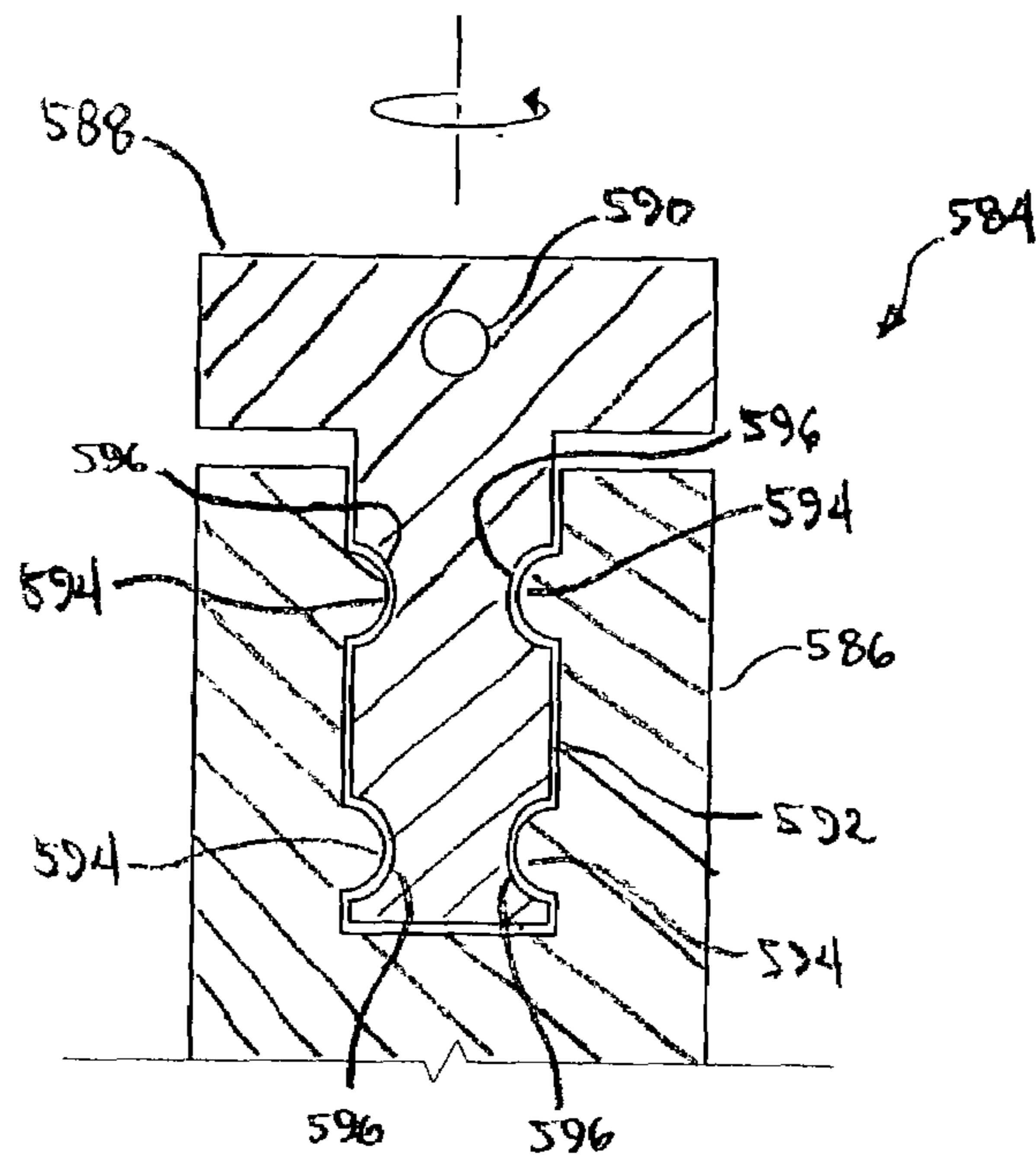

FIG. 52C

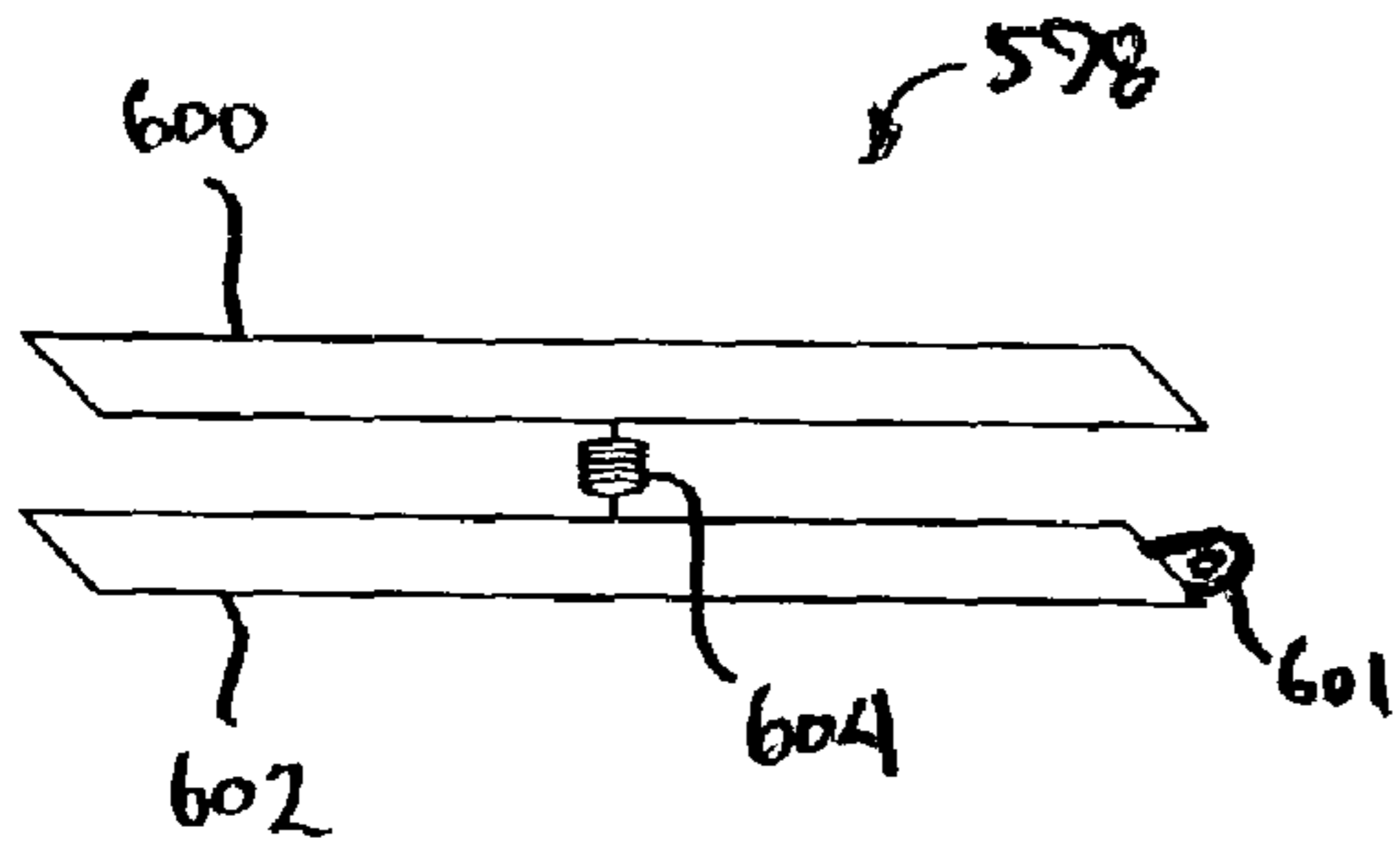

FIG. 53A

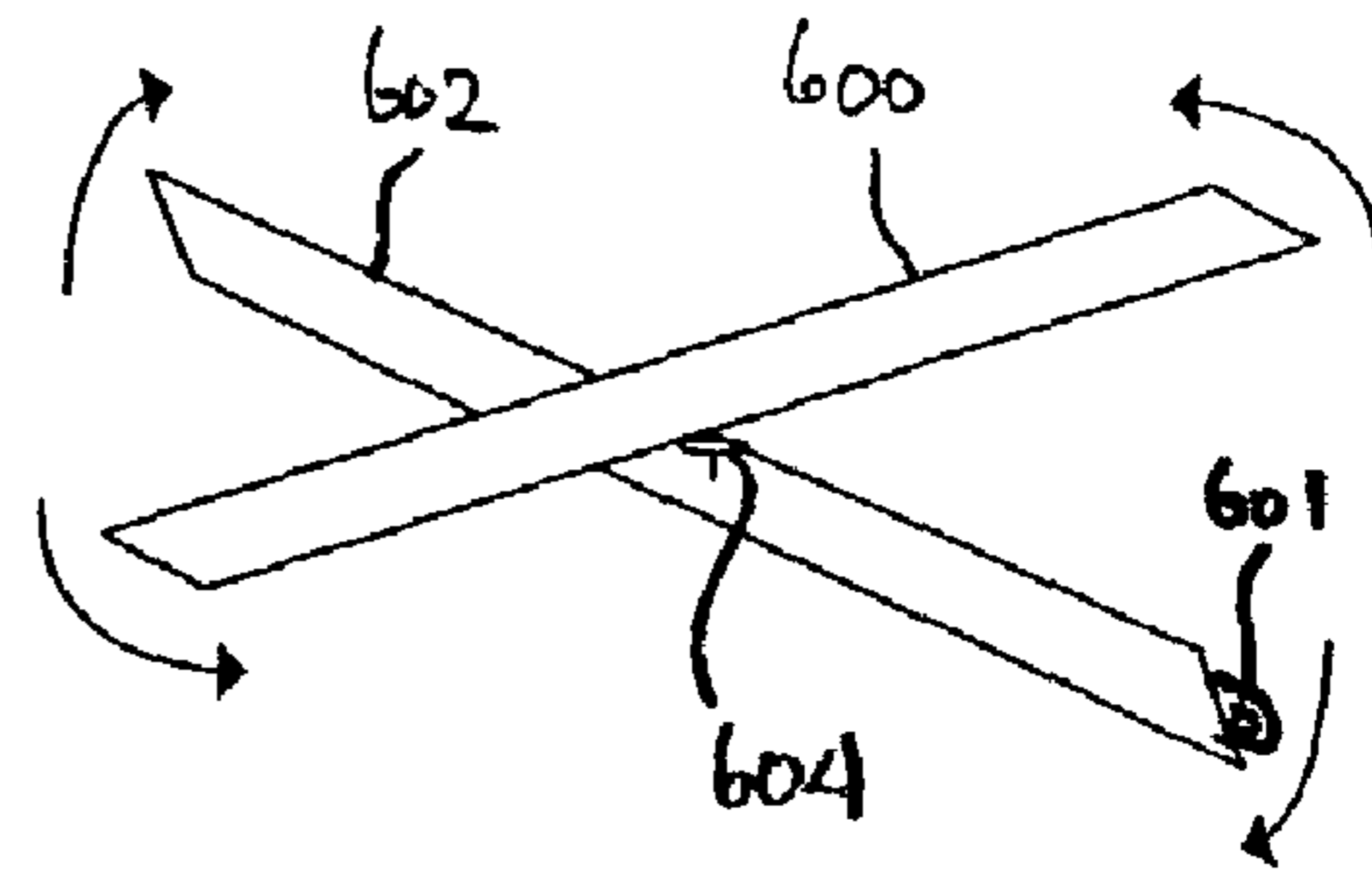

FIG. 53B

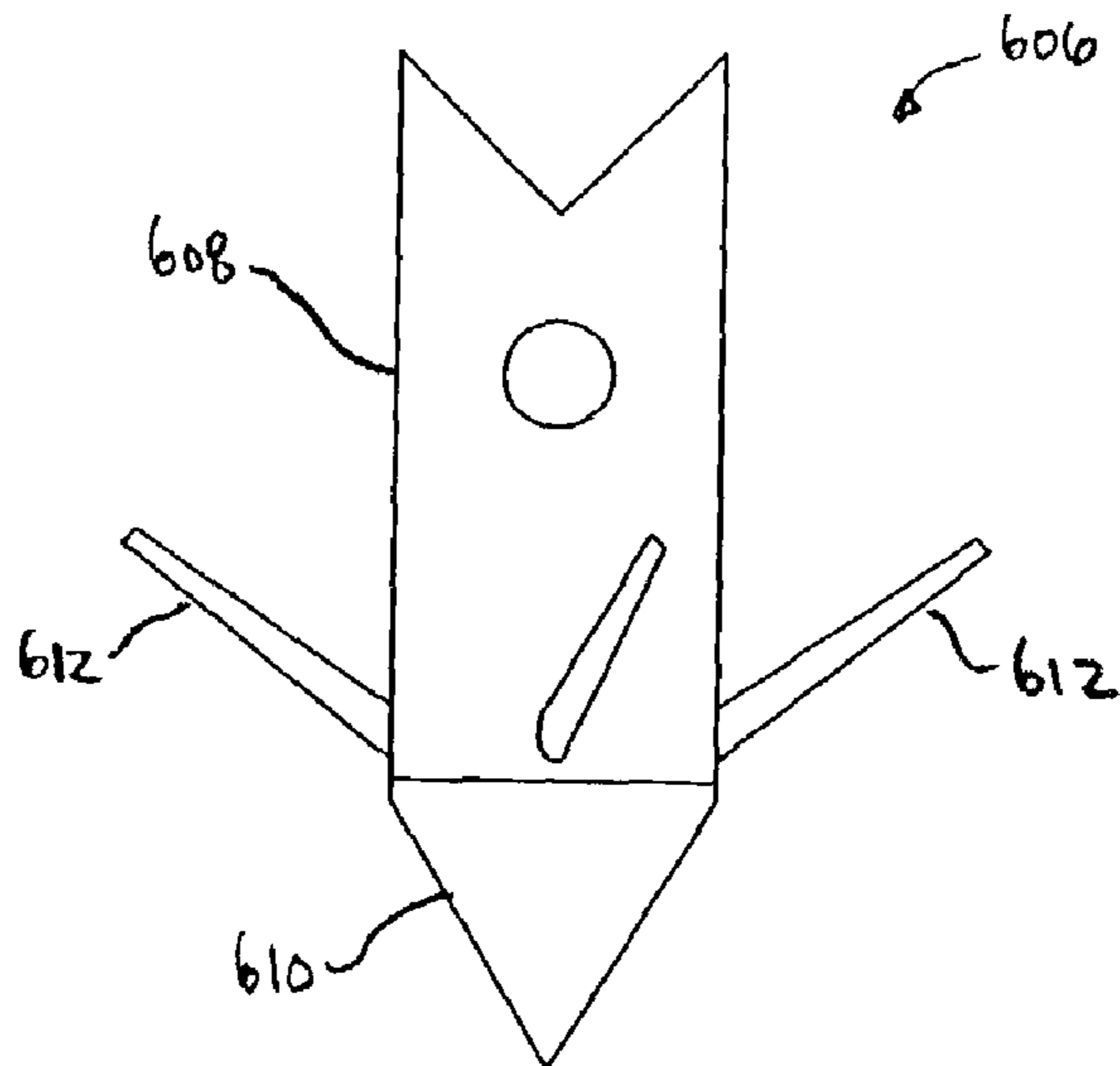

FIG. 54

APPARATUS AND METHODS FOR TREATING TISSUE

CROSS-REFERENCE TO RELATED APPLICATIONS

This application is a continuation-in-part of U.S. patent application Ser. No. 09/898,726 filed Jul. 3, 2001, now U.S. Pat. No. 6,626,899B2, which is a continuation-in-part of U.S. patent application Ser. No. 09/602,436 filed Jun. 23, 2000, now U.S. Pat. No. 6,669,687B1, which in turn claims benefit from U.S. Provisional Patent Application Ser. No. 60/141,077 filed Jun. 25, 1999, each of which is incorporated herein by reference in its entirety.

FIELD OF THE INVENTION

The present invention relates to treatment of tissue. More particularly, the present invention provides methods and apparatus for treating valvular disease with a catheter inserted into a patient's cardiac chambers, the catheter having an end effector for modifying cardiac structures, including valve leaflets and support structure.

BACKGROUND OF THE INVENTION

Degenerative valvular disease is the most common cause of valvular regurgitation in human beings. Regurgitation is typically characterized by an expanded valve annulus or by lengthened chordae tendineae. In either case, an increase in the geometry of a valve or its supporting structure causes the valve to become less effective, as it no longer fully closes when required.

Loose chordae tendineae may result, for example, from ischemic heart disease affecting the papillary muscles. The papillary muscles attach to the chordae tendineae and keep the leaflets of a valve shut. Some forms of ischemic cardiac disease cause the papillary muscles to lose their muscle tone, resulting in a loosening of the chordae tendineae. This loosening, in turn, allows the leaflets of the affected valve to prolapse, causing regurgitation.

It therefore would be desirable to provide methods and apparatus for treatment of tissue that modify the geometry and operation of a heart valve.

It would also be desirable to provide methods and apparatus that are configured to thermally treat chordae tendineae, the annulus of a valve, or valve leaflets.

It would also be desirable to further provide methods and apparatus that are configured to mechanically modify the geometry and operation of a heart valve and annulus of a valve either alone or in addition to thermal treatment.

SUMMARY OF THE INVENTION

In view of the foregoing, it is an object of the present invention to provide methods and apparatus for the treatment of tissue that modify the geometry and operation of a heart valve.

It is another object of the present invention to provide methods and apparatus that are configured to thermally treat chordae tendineae, the annulus of a valve, or valve leaflets.

It is another object of the present invention to further provide methods and apparatus that are configured to mechanically modify the geometry and operation of a heart valve and annulus of a valve either alone or in addition to thermal treatment.

These and other objects of the present invention are accomplished by providing apparatus and methods for thermally or mechanically treating tissue, such as valvular structures, to reconfigure or shrink the tissue in a controlled manner, thereby improving or restoring tissue function. Embodiments of the present invention advantageously may be employed to modify flow regulation characteristics of a cardiac valve or its component parts, as well as to modify flow regulation in other lumens of the body, including, for example, the urinary sphincter, digestive system valves, leg vein valves, etc., where thermal shrinkage or mechanical reconfiguration of tissue may provide therapeutic benefit.

In a first family of embodiments of the present invention, apparatus is provided having an end effector that induces a temperature rise in an annulus of tissue surrounding the leaflets of a valve sufficient to cause shrinkage of the tissue, thereby reducing a diameter of the annulus and causing the valves to close more tightly. In a second family of embodiments, apparatus is provided having an end effector that selectively induces a temperature rise in the chordae tendineae sufficient to cause a controlled degree of shortening of the chordae tendineae, thereby enabling the valve leaflets to be properly aligned. In yet a third family of embodiments, apparatus is provided having an end effector comprising a mechanical reconfigurer configured to attach to a longitudinal member, such as the chordae tendineae. The reconfigurer forces the longitudinal member into a tortuous path and, as a result, reduces the member's effective overall or straight length.

Any of these embodiments may employ one or more expanding members that serve to stabilize the end effector in contact with the tissue or structure to be treated. In addition, where it is desired to preserve the interior surface of a lumen or structure, the instrument may include means for flushing the surface of the tissue with cooled saline. Where it is desired to achieve a predetermined degree of heating at a depth within a tissue or structure, the end effector may comprise a laser having a wavelength selected to penetrate tissue to the desired depth, or the end effector may comprise a plurality of electrically conductive needles energized by an RF power source, as is known in the electrosurgical arts. The end effector may alternatively comprise an acoustic heating element, such as an ultrasonic transducer.

In another aspect of the present invention, mechanical clips may be provided preferably made from shape memory alloys or superelastic alloys, e.g., Nickel-Titanium alloy (nitinol). Such clips may be delivered to the valve and annulus of tissue surrounding the valve in a variety of ways, e.g., intravascularly, endoscopically, or laparoscopically, either after the thermal treatment described above, or without the thermal treatment. During delivery by, e.g., a catheter, the clips may be compressed into a smaller configuration to facilitate transport. Upon exiting the catheter, the clips preferably expand to a second configuration for attachment to the valve tissue. The clips may be attached to the annulus of tissue surrounding the valve upon being urged out of the catheter distal end; they may be attached to opposing sides of the valve and preferably have a compressive spring force to draw or cinch the sides of the valve towards one another. The clips may be configured to traverse directly over the valve itself, but they are preferably configured to lie partially over the periphery of the valve to prevent obstruction of the valve channel. A central region of the clips may be formed in a variety of geometric shapes, e.g., semi-circles, arcs, half-ellipses, triangles, rectangles, and loops. Aside from clips, expandable meshes and grids may also be used to draw or cinch the valve edges together.

Moreover, the clips may be coated with therapeutic drugs, which may be time-released, or they may also be coated at least partially with a radiopaque coating to aid in visualization during implantation.

Aside from mechanical clips, individual anchors having a tightening element, such as a suture or wire, threaded through each anchor may alternatively be deployed around the valve. When desirably placed, the tightening element may be tightened to draw each of the anchors towards one another, thereby reducing the valve diameter.

Delivery catheters which may be used to deliver the clips may also incorporate sensors or energy delivery devices, e.g., transducers, on the distal ends. For example, they may be configured as a sensor to measure properties, e.g., ultrasound, Doppler, electrode, pressure sensor or transducer, etc., of the tissue prior to catheter withdrawal. Such sensors may also be used to measure properties such as flow rates, pressure, etc. for measurement pre-treatment and post-treatment. Alternatively, they may also be used as a transducer to deliver energy, e.g., RF, electrical, heat, etc., to the affected tissue or the surrounding area by, e.g., either as a separate device or directly through the clip itself.

Methods of using apparatus according to the present invention are also provided.

BRIEF DESCRIPTION OF THE DRAWINGS

The above and other objects and advantages of the present invention will be apparent upon consideration of the following detailed description, taken in conjunction with the accompanying drawings, in which like reference numerals refer to like parts throughout, and in which:

FIG. 1 is a side-sectional view of a human heart showing major structures of the heart, including those pertaining to valvular degeneration;

FIG. 2 is a side view of apparatus of a first family of embodiments constructed in accordance with the present invention;

FIGS. 3A–3C are, respectively, a side view of an end effector for use with the apparatus of FIG. 2 and a sectional view through its catheter along sectional view line A–A, a side view of an alternative end effector and a sectional view of its catheter along view line B–B, and a side view of a still further alternative end effector;

FIG. 4 is a sectional view through the human heart, depicting a method of using the apparatus of FIG. 2 to shrink tissue in an annulus surrounding the leaflets of a regurgitating valve;

FIGS. 5A and 5B are schematic views of alternative embodiments of the apparatus of FIG. 2;

FIGS. 6A–6D are views of a still further alternative embodiment of the apparatus of FIG. 2 having barbs, and illustrating a method of use;

FIGS. 7A–7C are schematic views showing, respectively, an alternative embodiment of the end effector of FIG. 6 having electrically insulated barbs, a method of using the end effector to thermally treat tissue, and a temperature profile within the tissue during treatment;

FIGS. 8A and 8B are side views of another alternative embodiment of the apparatus of FIG. 6 having multipolar, individual electrodes;

FIG. 9 is a side view of an alternative embodiment of the apparatus of FIG. 8 having individual ultrasonic transducers;

FIG. 10 is a side-sectional view of another alternative embodiment of the apparatus of FIG. 8 having individual laser fibers;

FIG. 11 is a side-sectional view of an alternative embodiment of the apparatus of FIGS. 8–10 having individual barb members that may comprise multipolar electrodes, ultrasonic transducers, or laser fibers;

FIG. 12 is a sectional view through the human heart, illustrating an alternative method of introducing apparatus of the first family of embodiments to a treatment site;

FIGS. 13A and 13B are views of an alternative embodiment of the apparatus of FIG. 2 shown, respectively, in schematic side view and in use shrinking an annulus of tissue;

FIGS. 14A and 14B are, respectively, a side view of an alternative embodiment of the apparatus of FIG. 2, and a method of using the embodiment via the introduction technique of FIG. 12;

FIGS. 15A and 15B are isometric views of an alternative end effector for use with the apparatus of FIG. 14;

FIG. 16 is a top view of apparatus of a second family of embodiments constructed in accordance with the present invention;

FIGS. 17A–17C are views of end effectors for use with the apparatus of FIG. 16;

FIG. 18 is a sectional view of the human heart, illustrating a method of using the apparatus of FIG. 16 to selectively induce a temperature rise in the chordae tendineae sufficient to cause a controlled degree of shortening of the tendineae;

FIGS. 19A–19C show a section of chordae tendineae and illustrate a method of shrinking the tendineae in a zig-zag fashion using the end effector of FIG. 17C with the apparatus of FIG. 16;

FIGS. 20A–20C show, respectively, a side view of an intact tendineae, a side view of the tendineae after treatment by a shrinkage technique, and a cross section through the tendineae along sectional view line C–C of FIG. 20A after treatment by an alternative shrinkage technique;

FIGS. 21A and 21B are side views of apparatus of a third family of embodiments, constructed in accordance with the present invention, shown in a collapsed delivery configuration and in an expanded deployed configuration;

FIGS. 22A and 22B are schematic views depicting a method of using the apparatus of FIG. 21 to mechanically shorten an effective length of chordae tendineae; and

FIG. 23 is a side view, partially in section, illustrating a method and apparatus for non-invasive coagulation and shrinkage of scar tissue in the heart, or shrinkage of the valve structures of the heart.

FIG. 24A is an isometric view of a variation on a valve resizing device as an expandable grid with anchoring ends.

FIG. 24B is a top view of another variation on the valve resizing device as an expandable mesh.

FIGS. 25A–25F are side views of exemplary anchors which may be used with a valve resizing device.

FIG. 26 is a cross-sectional superior view of a heart section with the atrial chambers removed for clarity with the device of FIG. 24A implanted over a valve.

FIGS. 27A and 27B are a top view showing variations on a circumferential clip.

FIG. 28 is a cross-sectional superior view of a heart section with the atrial chambers removed for clarity with the device of FIG. 27A implanted around a valve.

FIGS. 29A and 29B show a side view and an end view, respectively, of a variation on a clip.

FIGS. 30A and 30B show a side view and an end view, respectively, of another variation on a clip.

FIGS. 31A–31D show a top, side, end, and isometric view, respectively, of a further variation on the clip.

FIGS. 32A–36B show top and side views of alternative variations on the clip.

FIG. 37 shows a cross-sectional view of a variation on the distal section of a delivery catheter.

FIG. 38 shows a cross-sectional view of another variation on the distal section of a delivery catheter where the clip is held in a different configuration.

FIG. 39 shows a cross-sectional view of yet another variation on the distal section of a delivery catheter.

FIGS. 40A and 40B are top and side views of a variation on a handle for controlling the advancement of the clip.

FIGS. 41A and 41B illustrate a cross-sectional view of a heart and a possible method of delivering and implanting a clip over the heart valve.

FIG. 41C is a cross-sectional view of a heart and a variation on the delivery catheter having a sensing device or a transducer integrated on the distal end.

FIGS. 42A–42D are cross-sectional superior views of a heart section with the atrial chambers removed showing an alternative method of delivering and implanting clips through the coronary sinus.

FIGS. 43A and 43B are a superior view and a side view of a valve, respectively, showing an alternative clip configuration implanted on the valve.

FIGS. 44A and 44B are cross-sectional superior views of a heart section with the atrial chambers removed for clarity with anchors implanted around the mitral valve.

FIG. 45 is a cross-sectional superior views of a heart section with the atrial chambers removed for clarity with anchors implanted within the coronary sinus to approximate the tissue around the mitral valve.

FIG. 46A shows a cross-sectional side view of one variation on a delivery catheter for delivering and implanting anchoring devices.

FIG. 46B shows an end view of the delivery catheter of FIG. 46A.

FIG. 46C shows a cross-sectional view of another variation on the delivery catheter of FIG. 46A.

FIG. 47 shows a cross-sectional side view of another variation on a delivery catheter for delivering and implanting anchoring devices.

FIG. 48 shows an isometric view of a cartridge/pusher device for use within a delivery catheter.

FIG. 49A shows an isometric view of one variation of a crimping/fastening device for maintaining a tightened suture.

FIGS. 49B–49E show cross-sectional side views of variations on the crimping/fastening device.

FIG. 50 shows an isometric view of an alternative device, with the wall partially removed, for severing a tensioning element using a heating element.

FIG. 51 shows a side view of a variation on an implantable anchor with a removable obturator.

FIGS. 52A–52C show side and cross-sectional side views of another variation on the anchor having a rotatable portion.

FIGS. 53A and 53B show constrained and deployed configurations for yet another variation on anchors.

FIG. 54 shows a side view of yet another variation on an anchor having a bioabsorbable piercing tip.

DETAILED DESCRIPTION OF THE INVENTION

With reference to FIG. 1, a sectional view through human heart H is presented. Major structures labeled include the right atrium RA, left atrium LA, right ventricle RV, left ventricle LV, superior vena cava SVC, inferior vena cava

IVC, and ascending aorta AA. Structures that may be involved in valvular degeneration and regurgitation are also labeled, including the papillary muscles PM, chordae tendineae CT, valve leaflets L, and annuluses of tissue surrounding the leaflets A, as well as the tricuspid valve TV, the bicuspid or mitral valve MV, and the aortic valve AV. The pulmonary valve PV is not seen in the cross section of FIG. 1, but may also experience valvular degeneration. As discussed previously, degenerative valvular disease often leads to valvular regurgitation, which is typically characterized by an expanded valve annulus A or by lengthened chordae tendineae CT. Loose chordae tendineae may result from ischemic heart disease affecting the papillary muscles PM, which attach to the chordae tendineae and act to regulate flow through leaflets L.

The present invention therefore provides apparatus and methods for shrinking or reconfiguring tissue, such as annulus A or chordae tendineae CT. The present invention also encompasses optionally altering a shape of the valve through mechanical attachments. The mechanical attachments, as discussed in detail below, may be done either after the shrinking or reconfiguring of the tissue, or it may be done as a stand-alone procedure. Embodiments of the present invention advantageously may be employed to modify flow regulation characteristics of a cardiac valve or its component parts, as well as to modify flow regulation in other lumens of the body, including, for example, the urinary sphincter, digestive system valves, leg vein valves, etc., where thermal shrinkage or mechanical reconfiguration of tissue may provide therapeutic benefit.

FIGS. 2–15 illustrate apparatus of a first family of embodiments of the present invention. The first family of embodiments have an end effector that induces a temperature rise in an annulus of tissue surrounding the leaflets of a valve sufficient to cause shrinkage of the tissue, thereby reducing a diameter of the annulus and causing the valve to close more tightly.

Referring to FIG. 2, apparatus 30 comprises catheter 32 having end effector 34 in a distal region of the catheter. End effector 34 may be collapsible within and extendable beyond the distal end of catheter 30 to permit percutaneous delivery to a treatment site. End effector 34 has an annular shape to facilitate treatment of an annulus of tissue, as well as stabilization against the walls of a treatment site.

With reference to FIGS. 3A–3C, alternative embodiments of end effector 34 and catheter 32 are described. In FIG. 3A, end effector 34 comprises expandable balloon 40. Balloon 40 comprises bipolar electrodes 42a and 42b that may be attached to a radiofrequency (“RF”) voltage or current source (not shown). Balloon 40 further comprises lumen 44 to facilitate unimpeded blood flow or fluid transport there-through, and temperature sensors 46 to monitor shrinkage of tissue caused by current flow between bipolar electrodes 42a and 42b. Sensors 46 may comprise, for example, standard thermocouples, or any other temperature sensor known in the art.

The end effector of FIG. 3A is thus capable of achieving controlled luminal shrinkage while allowing blood to pass through the center of balloon 40. Electrodes 42a and 42b are disposed as bands on the periphery of balloon 40 and may inject an RF electrical current into the wall of a treatment site, such as an annulus or lumen, to shrink collagen contained therein. Furthermore, balloon 40 may be inflated with a circulating coolant C, such as water, to cool the surface of balloon 40 and thereby minimize thermal damage at the surface of the treatment site. Thermally damaged tissue may

be thrombogenic and may form thrombus on its surface, leading to potentially lethal complications.

FIG. 3A also provides a cross section through an embodiment of catheter 32, along sectional view line A—A, for use in conjunction with the balloon embodiment of end effector 34. Catheter 32 comprises coolant lumens 48a and 48b that may circulate coolant C into and out of balloon 40, respectively. It further comprises wires 49a–49c, electrically coupled to electrode 42a, electrode 42b, and temperature sensors 46, respectively.

In FIG. 3B, an alternative embodiment of end effector 34 and catheter 32 is presented. Instead of RF energy, the heating element in this embodiment is a laser source (not shown) coupled to fiber optic cable 50 having side firing tip 51. The laser source injects light energy into the wall of a treatment site via fiber optic cable 50, thereby thermally shrinking the tissue. The wavelength of the laser may be selected to penetrate tissue to a desired depth. Furthermore, a plurality of fiber optic cables 50, coupled to the laser source and disposed about the circumference of balloon 40, may be provided.

Balloon 40 is substantially transparent to the laser energy, and coolant C may again serve to cool the surface of balloon 40, thereby minimizing damage at the surface of the treatment site. The circulating stream of coolant C maintains the temperature of surface tissue layers at a sufficiently low level to prevent thermal damage, and thus, to prevent formation of thrombus. Temperature sensor 46 optionally may also be provided.

As seen in FIG. 3C, end effector 34 may alternatively comprise wrapped sheet 52 incorporating one or more electrodes on its surface. Sheet 52 may be advanced to a treatment site in a collapsed delivery configuration within a lumen of catheter 32, and may then be unfurled to an expanded deployed configuration wherein it contacts the interior wall of the treatment site and may be energized to shrink tissue.

Referring now to FIG. 4, a method of using apparatus 30 to thermally shrink an annulus of tissue is described. End effector 34 is placed in intimate contact with the inner wall of a blood vessel or other body lumen. In the valvular regurgitation treatment technique of FIG. 4, end effector 34 is percutaneously delivered just proximal of aortic valve AV within ascending aorta AA at annulus of tissue A supporting leaflets L, using well-known techniques. Aortic valve AV suffers from valvular degeneration, leading to regurgitation. End effector 34 delivers energy to annulus A sufficient to heat and shrink the annulus, thus enhancing function of the degenerative valve.

Collagen within annulus A shrinks and reduces a diameter of the annulus. Leaflets L are approximated towards one another, as seen in dashed profile in FIG. 4, and valvular regurgitation is reduced or eliminated. In addition to valvular regurgitation, the technique is expected to effectively treat aortic insufficiency.

End effector 34 stabilizes apparatus 30 against the wall of a body passageway. Once stabilized, a source of energy may be applied to the wall to thermally shrink the tissue contained in the wall. In addition to the application of FIG. 4, treatment may be provided, for example, to the annulus of mitral valve MV, to the urinary sphincter for treatment of incontinence, to digestive system valves for treatment of acid reflux, to leg vein valves, and to any other annulus of tissue where treatment is deemed beneficial.

With reference to FIGS. 5A and 5B, alternative embodiments of the apparatus of FIG. 2 are described. In FIG. 5A, apparatus 60 comprises catheter 62 having a lumen, in which

end effector 64 is advanceably disposed. End effector 64 comprises monopolar electrode 66, which is fabricated in an arc from a shape memory alloy, such as spring steel or nitinol, to approximate the shape of an annulus of tissue at a treatment site within a patient. Electrode 66 may be retracted within the lumen of catheter 62 to facilitate trans-luminal, percutaneous delivery to the treatment site. Once in position, electrode 66 may be advanced out of a distal region of catheter 62. The electrode resumes its arc shape and approximates the wall of the treatment site.

Monopolar electrode 66 is electrically coupled to RF source 68, which is positioned outside of the patient. RF source 68 is, in turn, coupled to reference electrode 69. When RF source 68 is activated, current flows between monopolar electrode 66 and reference electrode 69, which may, for example, be attached to the exterior of the patient in the region of the treatment site. RF current flows into the wall of the treatment site, thereby effecting annular tissue shrinkage, as described previously.

In FIG. 5B, a bipolar embodiment is provided. Apparatus 70 comprises catheter 72 and end effector 74. End effector 74 comprises a plurality of atraumatic tipped legs 76 that are electrically coupled by a plurality of current carrying wires 78 to an RF source (not shown). The plurality of legs contact the wall of a treatment site and inject current into the wall. The current flows between the tips of the legs. Alternatively, the plurality of legs may comprise a monopolar electrode coupled by a single wire to the RF source, and current may flow between the plurality of legs and a reference electrode, as in FIG. 5A.

Referring to FIGS. 6A–6D, another alternative embodiment of the apparatus of FIG. 2 is described. FIG. 6A shows apparatus 80 in side-sectional view in a retracted delivery configuration. Apparatus 80 comprises catheter 82 and end effector 84. Catheter 82 further comprises central bore 86, a plurality of side bores 88, and optional temperature sensors 90. End effector 84 may, for example, be fabricated from nitinol or spring steel, and comprises conductive shaft 92 having a plurality of radially extending electrodes 94 with optional barbs 96. Conductive shaft 92 is electrically coupled to RF source 98, which is electrically coupled to reference electrode 99. Conductive shaft 92 is disposed within central bore 86, while electrodes 94 are disposed within side bores 88.

End effector 84 is advanceable with respect to catheter 82. When advanced distally, apparatus 80 assumes the expanded deployed configuration of FIG. 6B, wherein electrodes 94 extend through side bores 88 beyond the surface of catheter 82. Apparatus 80 is also configured such that its distal region may approximate the shape of an annulus of tissue, as described hereinbelow with respect to FIG. 6D, and is thus suited for both linear and circular subsurface tissue coagulation and shrinkage.

FIGS. 6C and 6D provide a method of using apparatus 80 to treat annulus of tissue A surrounding a heart valve. Apparatus 80 is percutaneously advanced to the surface of a heart valve in the delivery configuration of FIG. 6C. Once positioned at annulus A, the distal region of apparatus 80 approximates the shape of the annulus, as seen in FIG. 6D. This may be accomplished, for example, with a steering mechanism comprising two purchase points or a pre-shaped tip that is retracted within a straight guiding catheter to allow insertion into the vascular system, as described in U.S. Pat. No. 5,275,162, which is incorporated herein by reference. Once inserted, the pre-shaped tip is advanced out of the guide catheter and recovers its preformed shape.

With apparatus **80** approximating annulus A, end effector **84** is distally advanced with respect to catheter **82**, thereby selectively advancing electrodes **94** into the annulus. RF source **98** then provides RF current, which flows between electrodes **94** and reference electrode **99**. The annulus of tissue shrinks, bringing valve leaflets into proper position and minimizing or eliminating regurgitation through the valve.

Catheter **82** insulates conductive shaft **92** from annulus A, thereby protecting surface tissue and only allowing coagulation at depth in treatment zones surrounding electrodes **94**. To further ensure that coagulation only occurs at depth, a coolant, such as saline, may be introduced through central bore **86** and side bores **88** of catheter **82** to the surface of annulus A, thereby cooling and flushing the area where electrodes **94** penetrate the tissue. It is expected that such liquid infusion will keep the surface of the annulus clean and will prevent thrombus formation in response to thermal damage.

Referring now to FIGS. 7A–7C, an alternative embodiment of end effector **84** of FIG. 6 is described. The end effector of FIG. 7 is equivalent to the end effector of FIG. 6 except that it is coated with electrically insulating layer I. Insulation layer I covers the entire exterior of end effector **84**, except at the distal ends of the plurality of electrodes **94**. The layer is preferably sufficiently thin to allow insertion of electrodes **94** into tissue T without impediment. The exposed distal ends of the electrodes are configured to deliver energy into subsurface tissue at treatment zones Z. The zones may be ideally modeled as spheres of subsurface tissue. Tissue shrinks within treatment zones Z without damaging surface tissue, as seen in FIG. 7B.

The size of treatment zones Z may be controlled to ensure that tissue remodeling only occurs at depth. Assuming a temperature T_1 , at which tissue damage is negligible, the magnitude of current passed through tissue T may be selected (based on the material properties of the tissue and the depth of insertion of electrodes **94** within the tissue) such that the temperature decays from a temperature T_0 at a position D_0 at the surface of an electrode **94** to the benign temperature T_1 at a distance D_1 from the surface of the electrode. The distance D_1 may be optimized such that it is below the surface of tissue T. An illustrative temperature profile across a treatment zone Z is provided in FIG. 7C.

With reference to FIGS. 8A and 8B, another alternative embodiment of the apparatus of FIG. 6 is described. Apparatus **100** comprises catheter **102** and end effector **104**. End effector **104** further comprises a plurality of individual, multipolar electrodes **106**, which are electrically coupled to an RF or other current source (not shown) by a plurality of current carrying wires **108**. As with the embodiments of FIGS. 6 and 7, apparatus **100** is configured such that end effector **104** may approximate an annulus, as seen in FIG. 8B.

Referring to FIGS. 9–11, alternative embodiments of the apparatus of FIG. 8 are described. In FIG. 9, apparatus **110** comprises catheter **112** and end effector **114**. End effector **114** comprises a plurality of acoustic heating elements **116**. Acoustic elements **116** may, for example, comprise ultrasonic transducers. The acoustic energy may further be focused by appropriate means, for example, by lenses, such that a tissue damage threshold sufficient to cause shrinkage is only attained at a specified depth within treatment site tissue, thereby mitigating surface tissue damage and thrombus formation. Acoustic elements **116** are connected to

appropriate controls (not shown). Apparatus **110**, and any other apparatus described herein, may optionally comprise temperature sensors **118**.

In FIG. 10, apparatus **120** comprises catheter **122** and end effector **124**. Catheter **122** comprises a plurality of central bores **126** and a plurality of side bores **128**, as well as a plurality of optional temperature sensors **130**. End effector **124** comprises a plurality of side-firing fiber optic laser fibers **132** disposed within central bores **126** of catheter **122**. The fibers are aligned such that they may deliver energy through side bores **128** to heat and induce shrinkage in target tissue. Fibers **132** are coupled to a laser source (not shown), as discussed with respect to FIG. 3B. Suitable wavelengths for the laser source preferably range from visible (488–514 nm) to infrared (0.9–10.6 microns), wherein each wavelength has an ability to heat tissue to a predetermined depth. As an example, a preferred laser source comprises a continuous wave laser having a 2.1 micron wavelength, which will shrink and heat tissue to a depth of 1–2 mm.

In FIG. 11, apparatus **140** comprises catheter **142** and end effector **144**. Catheter **142** comprises central bores **146** and side bores **148**. Catheter **142** further comprises temperature sensors **150** that are configured to penetrate superficial tissue layers to measure temperature at depth. Temperature sensors **150** may be retractable and extendable to facilitate percutaneous delivery of apparatus **140**. End effector **144** comprises fibers **152** disposed within central bores **146**. Fibers **152** are retractable within and extendable beyond side bores **148**. Fibers **152** are preferably sharpened to facilitate tissue penetration and energy delivery to subsurface tissue, thereby inducing shrinkage of the tissue.

Fibers **152** may comprise any of a number of energy delivery elements. For example, fibers **152** may comprise a plurality of optical fibers coupled to a laser (not shown). The wavelength of the laser may be selected as described hereinabove, while the energy deposited by the fibers may be controlled responsive to the temperature recorded by sensors **150**. Thus, for example, a controller (not shown) may be provided to switch off the laser once a preset temperature, for example, 45° C.–75° C., is attained, thereby ensuring that a sufficiently high temperature is achieved to cause tissue shrinkage without inadvertently damaging surrounding tissues.

Fibers **152** may alternatively comprise a plurality of multipolar electrodes. Each electrode may be capable of injecting RF energy into tissue independently. Alternatively, current may be passed between a pair of adjacent or non-adjacent electrodes to heat intervening tissue.

Referring now to FIG. 12, an alternative method of introducing apparatus of the first family of embodiments, to a treatment site is described. Apparatus **30** of FIG. 2 is introduced to the annulus of tissue A surrounding mitral valve MV via the venous circulatory system. Catheter **32** is transluminally inserted via the jugular vein and superior vena cava SVC. The distal end of the catheter or a separate instrument then penetrates atrial septum AS using a procedure known as septostomy. Once the septum is perforated, end effector **34** may be inserted into left atrium LA and positioned over mitral valve annulus A to effect the thermal treatment described hereinabove. The tricuspid valve in the right ventricle, and the pulmonic valve, may also be treated in the same manner using a venous approach.

Referring to FIGS. 13A and 13B, a further alternative embodiment of the apparatus of FIG. 2 is described that may be introduced using the technique of FIG. 4, the technique of FIG. 12, or by another suitable technique. Apparatus **160** comprises catheter **162** and end effector **164**. End effector

164 comprises adjustable, heatable loop **166**, which is configured for dynamic sizing to facilitate positioning next to tissue at a treatment site. The size of loop **166** is adjusted so as to lie contiguous with annulus of tissue A at a treatment site, as seen in FIG. **13B**. The loop may be collapsible within catheter **162** to facilitate percutaneous delivery and is electrically coupled to RF source **168**, which is electrically coupled to reference electrode **170**. Loop **166** may be fabricated from nitinol, copper, or any other suitably conductive and ductile material.

Referring to FIGS. **14A** and **14B**, a still further alternative embodiment of the apparatus of FIG. **2**, and a method of using the embodiment with the introduction technique of FIG. **12**, is described. Apparatus **170** comprises catheter **172** and end effector **174**. End effector **174** is capable of grabbing and penetrating tissue, as well as delivering RF energy into tissue. End effector **174** comprises jaws **176a** and **176b**, which are spring-biased against one another to a closed position. By pushing a knob on the handpiece (not shown), the jaws may be actuated to an open position configured to grab tissue at a treatment site. RF energy may then be deposited in the tissue in a monopolar or bipolar mode. Jaws **176** may optionally be coated with electrically insulating layer I everywhere except in a distal region, such that tissue is only treated at depth, as described hereinabove. End effector **174** has temperature sensor **178** to control power delivered to the tissue, again as described hereinabove.

With reference to FIG. **14B**, a method of using apparatus **170** via a septostomy introduction technique to treat mitral valve regurgitation is described. In particular, jaws **176** of end effector **174** are actuated to engage individual sections of valve annulus A so as to penetrate into the collagenous sublayers and to thermally shrink those sublayers. The procedure may be repeated at multiple locations around the perimeter of annulus A until regurgitation is minimized or eliminated.

FIGS. **15A** and **15B** show an alternative end effector for use with apparatus **170** of FIGS. **14**. End effector **180** is shown in an open position and in a closed position, respectively, and comprises jaws **182a** and **182b**. End effector **180** is similar to end effector **174**, except that jaws **182** are configured to engage tissue with a forceps grasping motion wherein bent tips **184a** and **184b** of the jaws are disposed parallel to one another and contact one another when closed.

With reference now to FIGS. **16–20**, apparatus of a second family of embodiments of the present invention are described. These embodiments are provided with an end effector that selectively induces a temperature rise in the chordae tendineae sufficient to cause a controlled degree of shortening of the chordae tendineae, thereby enabling valve leaflets to be properly aligned.

A preferred use for apparatus of the second family is in treatment of mitral valve regurgitation. Mitral valve regurgitation has many causes, ranging from inherited disorders, such as Marfan's syndrome, to infections and ischemic disease. These conditions affect the macromechanical condition of the mitral valve and prevent the valve from closing completely. The resulting gap in the leaflets of the valve permit blood to regurgitate from the left ventricular chamber into the left atrium.

Mechanically, the structural defects characterizing mitral valve regurgitation include: (1) the chordae tendineae are too long due to a given disease state; (2) papillary muscle ischemia changes the shape of the papillary muscle, so that attached chordae tendineae no longer pull the leaflets of the mitral valve completely shut; (3) the annulus of the mitral valve becomes enlarged, resulting in the formation of a gap

between the leaflets when closed; and (4) there is an inherent weakness in the leaflets, leaving the leaflets floppy and dysfunctional.

In accordance with the principles of the present invention, a temperature rise is induced in the support structure of the mitral valve to cause shrinkage that modifies the geometry of the valve to restore proper stopping of blood backflow and thereby regurgitation. This process is depicted in FIGS. **18–20** using the apparatus of FIGS. **16** and **17** to selectively shrink portions of the chordae tendineae, thereby bringing leaflets of the mitral valve leaflets into alignment. Apparatus of the second family may also be used in treatment of aortic valve regurgitation, and in treatment of a variety of other ailments that will be apparent to those of skill in the art.

Referring to FIG. **16**, apparatus **200** comprises catheter **202** and end effector **204**. Catheter **204** optionally comprises collapsible and expandable stabilizer **206**, configured to stabilize apparatus **200** in a body lumen. Stabilizer **206** may comprise, for example, struts or an inflatable balloon.

End effector **204** may be collapsible to a delivery configuration within catheter **202**, and may expand to a delivery configuration beyond a distal end of the catheter. End effector **204** is configured to engage, heat, and shrink chordae tendineae. Various sources of energy may be used to impart heat to the collagenous tissue and thereby shrink it, including RF energy, focused ultrasound, laser energy, and microwave energy. In addition, chemical modifiers, such as aldehydes, may be used. For laser embodiments, a preferred laser is a continuous wave Holmium:Yag laser, with application of visible or infrared laser energy in the wavelength range of 400 nanometers to 10.6 micrometers.

With reference to FIGS. **17A–17C**, embodiments of end effector **204** are described. In FIG. **17A**, the end effector comprises a gripping mechanism that carries the heating element. Arms **210a** and **210b** are opposing and spring-biased against each other. The arms may be actuated to an open position using a handpiece (not shown) coupled thereto. Arms **210a** and **210b** may alternatively be vertically displaced with respect to one another to allow the arms to criss-cross and tightly grasp tissue. Heating elements **212** and temperature sensors **214** are attached to the arms. Heating elements **212** may comprise electrodes, acoustic transducers, side-firing laser fibers, radioactive elements, etc. It may be desirable to employ a saline flush with heating elements **212** to prevent coagulation of blood caught between arms **210**.

FIG. **17B** shows an embodiment of end effector **204** with fixed, straight arms **220a** and **220b**. The arms are configured to engage and disengage chordae tendineae simply by being positioned against the tendineae. FIG. **17C** shows an embodiment of the end effector having arms **230a** and **230b**. Multiple heating elements **212** are disposed on arm **230a**. When heating elements **212** comprise bipolar electrodes, current flow through the tendineae using the embodiment of FIG. **17C** may be achieved primarily along a longitudinal axis of the tendineae, as opposed to along a radial axis of the tendineae, as will be achieved with the embodiment of FIG. **17A**. These alternative heating techniques are described in greater detail hereinbelow with respect to FIGS. **19** and **20**.

Referring to FIG. **18**, a method of using apparatus of the second family of embodiments to induce shrinkage of chordae tendineae CT is described. Catheter **202** of apparatus **200** is advanced percutaneously, using well-known techniques, through the ascending aorta AA and aortic valve AV into the left ventricle LV, with end effector **204** positioned within the catheter in the collapsed delivery configura-

ration. Stabilizer **206** is then deployed to fix catheter **202** in ascending aorta AA, thereby providing a stationary leverage point.

End effector **204** is expanded to the deployed configuration distal of catheter **202**. The end effector is steerable within left ventricle LV to facilitate engagement of chordae tendineae CT. End effector **204**, as well as any of the other end effectors or catheters described herein, may optionally comprise one or more radiopaque features to ensure proper positioning at a treatment site. End effector **204** is capable of moving up and down the chordae tendineae to grab and selectively singe certain sections thereof, as illustrated in dotted profile in FIG. **18**, to selectively shorten chordae tendineae CT, thereby treating valvular regurgitation.

When energy is transmitted through tissue utilizing one of the embodiments of this invention, the tissue absorbs the energy and heats up. It may therefore be advantageous to equip the end effector with temperature or impedance sensors, as seen in the embodiments of FIGS. **17**, to output a signal that is used to control the maximum temperature attained by the tissue and ensure that the collagen or other tissues intended to be shrunk are heated only to a temperature sufficient for shrinkage, for example, a temperature in the range of 45° C.–75° C., and even more preferably in the range of 55° C.–65° C. Temperatures outside this range may be so hot as to turn the tissue into a gelatinous mass and weaken it to the point that it loses structural integrity. A closed loop feedback system advantageously may be employed to control the quantity of energy deposited into the tissue responsive to the output of the one or more sensors. In addition, the sensors may permit the clinician to determine the extent to which the cross-section of a chordae has been treated, thereby enabling the clinician to heat treat only a portion of the cross-section.

This technique is illustrated in FIGS. **19** and **20**, in which alternating bands, only a single side, or only a single depth of the chordae is shrunk to leave a “longitudinal intact fiber bundle.” This method may be advantageous in that, by avoiding heat treatment of the entire cross section of the chordae, there is less risk of creating mechanical weakness.

FIGS. **19A–19C** depict a method of shrinking a section of chordae tendineae CT in a zig-zag fashion using the embodiment of end effector **204** seen in FIG. **17C**. In FIG. **19A**, the tendineae has an initial effective or straight length L_1 . Arms **230** engage chordae tendineae CT, and heating elements **212** are both disposed on the same side of the tendineae on arm **230a**. The heating elements may comprise bipolar electrodes, in which case the path of current flow through tendineae CT is illustrated by arrows in FIG. **19A**.

Collagen within the tendineae shrinks, and chordae tendineae CT assumes the configuration seen in FIG. **19B**. Treatment zone Z shrinks, and the tendineae assumes a shorter effective length L_2 . Treatment may be repeated on the opposite side of the tendineae, as seen in FIG. **19C**, so that the tendineae assumes a zig-zag configuration of still shorter effective length L_3 . In this manner, successive bands of treatment zones Z and intact longitudinal fiber bundles may be established.

An additional pair of bipolar electrodes optionally may be disposed on arm **230b** of the end effector to facilitate treatment in bands on opposite sides of chordae tendineae CT. The depth of shrinkage attained with apparatus **200** is a function of the distance between the electrodes, the power, and the duration of RF energy application. If, laser energy is applied, the wavelengths of energy application may be selected to provide only partial penetration of the thickness of the tissue. For example, continuous wave Holmium:YAG

laser energy having a wavelength of 2.1 microns penetrates a mere fraction of a millimeter and may be a suitable energy source.

FIGS. **20A–20C** illustrate additional shrinkage techniques. Intact chordae tendineae CT is seen in FIG. **20A**. FIG. **20B** demonstrates shrinkage with apparatus **200** only on one side of the chordae, using the technique described with respect to FIGS. **19**. FIG. **20C** demonstrates shrinkage with, for example the end effector of FIG. **17A** or **17B**, wherein, for example, bipolar current flows across the tendineae and treats the tendineae radially to a certain preselected depth. When viewed in cross-section along sectional view line C—C of FIG. **20A**, chordae tendineae CT has an intact longitudinal fiber bundle core C surrounded by treatment zone Z.

With reference to FIGS. **21–22**, apparatus of a third family of embodiments of the present invention are described. These embodiments are provided with an end effector comprising a mechanical reconfigurer configured to engage a longitudinal member, such as the chordae tendineae. The reconfigurer forces the longitudinal member into a tortuous path and, as a result, reduces the member's effective overall or straight length.

Referring to FIGS. **21A** and **21B**, apparatus **300** comprises catheter **302** and end effector **304**. End effector **304** comprises mechanical reconfigurer **306**, adapted to mechanically alter the length of a longitudinal member, for example, chordae tendineae. Reconfigurer **306** comprises a preshaped spring fabricated from a shape memory alloy, for example, nitinol, spring steel, or any other suitably elastic and strong material. Reconfigurer **306** is preshaped such that there is no straight path through its loops. Overlap between adjacent loops is preferably minimized. The shape of reconfigurer **306** causes longitudinal members, such as chordae tendineae, passed therethrough to assume a zig-zag configuration and thereby be reduced in effective length. Reconfigurer **306** is collapsible to a delivery configuration within catheter **302**, as seen in FIG. **21A**, and is expandable to a deployed configuration, as seen in FIG. **21B**. The reconfigurer optionally may be selectively detachable from catheter **302**.

With reference to FIGS. **22A** and **22B**, a method of using apparatus **300** to mechanically shorten chordae tendineae CT is described. Apparatus **300** is advanced to the chordae tendineae, for example, using the technique described hereinabove with respect to FIG. **18**. End effector **304** is then expanded from the delivery configuration seen in FIG. **22A** to the deployed configuration of FIG. **22B**. Mechanical reconfigurer **306** regains its preformed shape, and chordae tendineae CT is passed through a tortuous path that reduces its effective length, thereby treating valvular regurgitation. Reconfigurer **306** may then be detached from apparatus **300** and permanently implanted in the patient, or the reconfigurer may be left in place for a limited period of time to facilitate complementary regurgitation treatment techniques.

Other embodiments of the third family in accordance with the present invention will be apparent to those of skill in the art in light of this disclosure.

Referring now to FIG. **23**, apparatus in accordance with the present invention is described that may be used as either an embodiment of the first family or of the second family. Apparatus and methods are provided for noninvasively coagulating and shrinking scar tissue around the heart, or valve structures inside the heart, using energy delivered via high intensity, focused ultrasound. Apparatus **350** comprises catheter **352** and end effector **354**. End effector **354** comprises ultrasonic transducer **356** and focusing means **358**, for

example, a lens. Focused ultrasound is propagated and directed with a high level of accuracy at the chordae CT, the annuluses A of the valves or at a section of bulging wall of the heart, using, for example, echocardiography or MRI for guidance. As with the previous embodiments, the shrinkage induced by energy deposition is expected to reduce valvular regurgitation. Apparatus 350 may also be used to reduce ventricular volume and shape, in cases where there is bulging scar tissue on the wall of the left ventricle LV secondary to acute myocardial infarction.

Alternatively, various mechanical valve resizing systems and methods may be used in conjunction with the apparatus and methods discussed above. Optionally, the various mechanical valve resizing systems and methods, as discussed below, may be used as a stand-alone system. These mechanical resizing systems may generally entail the positioning, deployment, and securing of one or more clips to bring the annular edges of a valve, e.g., a heart valve, or opening together to correct for valvular regurgitation. This would typically result in the reduction of the effective diameter of the valve or opening. The clip is preferably made of superelastic or shape memory materials, e.g., Nickel-Titanium alloys, because of the ability of these types of materials to be easily formed, e.g., by annealing, into desirable geometries. Such materials are very strong and have the ability to be constrained into a reduced diameter size for deployment as well as being capable of providing a permanent compressive spring force.

The variations of clip geometries described herein may be manufactured in several ways. One method involves securing a wire, band, or other cross-sectioned length, preferably made of a superelastic or shape memory material, to a custom forming fixture (not shown). The fixture preferably has a geometry similar to the valve or opening where the completed clip is to be placed and the fixture preferably has a diameter which is smaller than the diameter of the valve or opening. The fixture diameter may be determined by the amount of closure by which the valve or opening may need to be closed or approximated to reduce or eliminate valvular regurgitation. The fixture, with a constrained clip placed thereon, may be subjected to a temperature of about 500° to 700° F. preferably for a period of about 1 to 15 minutes. Additional details about the processing and performance of superelastic and shape memory materials may be seen in U.S. Pat. No. 5,171,252 to Friedland, which is incorporated herein by reference in its entirety. The fixture and clip may then be removed and subjected to rapid cooling, e.g., quenching in cold water. The clip may then be removed from the fixture and the ends of the clip may be trimmed to a desired length. The trimmed ends may also be formed into a sharpened point by, e.g., grinding, to facilitate piercing of the tissue.

FIG. 24A shows a variation of a valve resizing device in expandable grid 360. Grid 360 is shown as having alternating member 362 formed of a continuous alternating length while forming several anchoring regions 364, which may be radiused. The number of alternating members (and number of resultant anchoring regions 364) formed may be determined by a variety of factors, e.g., the geometry of the valve to be resized or the amount of spring compression required. Grid 360 is preferably made of a shape memory alloy, as discussed above. The terminal ends of alternating member 362 preferably end in anchoring ends 366. Anchoring ends 366 may define a range of angles with the plane formed by alternating member 362, e.g., 45°, but is preferably formed perpendicular to the plane. Ends 366 may be formed integrally from alternating member 362, which may first be cut

to length, by reducing a diameter of ends 366 to form, e.g., a barbed end or double-barbed end as shown in the figure and in the detail view. Alternatively, anchoring ends 366 may be formed separately and attached to the ends of alternating member 362 by, e.g., adhesives, welding, or scarf joints. The ends 366 are shown in this example as a double-barbed anchoring fastener, but generally any type of fastening geometry may be used, e.g., single-barbs, semi-circular or triangular ends, screws, expandable locks, hooks, clips, and tags, or generally any type of end geometry that would facilitate tissue insertion yet resist being pulled or lodged out. Also, sutures and adhesives, as well as the barbs, may be used to fasten grid 360 to the tissue.

Another variation on a grid-type device is shown in FIG. 24B as expandable mesh 368. In this variation, several individual interwoven members 370 may be woven together to form a continuous mesh. Members 370 may be either welded together or loosely interwoven to form expandable mesh 368. In either case, the geometries of both expandable grid 360 and mesh 368 are formed to preferably allow a compressive spring force yet allow a relative degree of expansion once situated on the valve or opening.

To maintain grid 360 or mesh 368 over the valve or opening, fasteners located around the valve or opening are preferably used for anchoring grid 360 or mesh 368. Fasteners are preferably made of a biocompatible material with relatively high strength, e.g., stainless steel or Nickel-Titanium. Biocompatible adhesives may also be used. A variation of such a fastener is shown in FIG. 25A. Anchor 372 is shown having a barbed distal end 374 for piercing tissue and for preventing anchor 372 from being pulled out. Shown with a double-barb, it may also be single-barbed as well. Stop 376, which is optional, may be located proximally of distal end 374 to help prevent anchor 372 from being pushed too far into the tissue. A protrusion, shown here as eyelet 378, is preferably located at the proximal end of anchor 372 and may extend above the tissue surface to provide an attachment point. Grid 360 or mesh 368 may be looped through eyelet 378 or they may be held to eyelet 378 by sutures or any other conventional fastening methods, e.g., adhesives.

Another variation on fasteners is shown in FIG. 25B. Here, locking anchor 380 is shown with distal end 382 having pivoting or butterfly-type lock 384. Stop 386 is preferably located proximally of distal end 382 and protrusion (or eyelet) 388 is preferably located at the proximal end of locking anchor 380. In use, pivoting lock 384 may be retracted against the shank of anchor 380 while being pushed into the tissue. When anchor 380 is pulled back, pivoting lock 384 may extend outwardly to help prevent anchor 380 from being pulled out of the tissue.

Yet another variation on fasteners is shown in FIGS. 25C–25F. FIG. 25D shows a side view of anchor 381, which is preferably barbed at the distal end 383 to facilitate insertion into tissue and subsequent anchoring. Proximal end 385 is indented in this variation to facilitate the loading and delivery of multiple anchors 381 to a tissue region for treatment. This may be accomplished by loading multiple anchors 381 within a delivery catheter such that the tapered proximal end of one anchor 381 abuts within the indentation 385 of the distal end of an adjacent anchor 381, as will be described in further detail below.

Defined within shank 389, which may have a diameter, e.g., of at least 0.2 mm, of anchor 381 is eyelet or suture hole 387. Eyelet 387 may be defined along anchor 381 such that it rests either above the tissue surface, at the tissue surface, or even below it when anchor 381 has been positioned

within the tissue. Eyelet **387** provides a hole through which a suture may be tied to or looped through to provide the desired anchoring points to draw the opposing sides of the valve towards one another. FIG. **25C** shows a cross-sectional end view taken from FIG. **25D** showing eyelet **387** defined through shank **389**. When a suture or other tensioning element, e.g., a wire, is drawn through eyelet **387** the suture may be tensioned, as described further below, and the remaining suture may be cut to leave the tensioned suture(s) and implanted anchors **381** in place within the tissue. To cut or remove the suture, eyelet **387** may have a sharpened or tapered edge **391** defined entirely around its circumference or just partially around, as shown in FIG. **25E**. When the suture has been positioned within eyelet **387**, a crimping or clamping tool (not shown) may be advanced to within the area and used to then crimp anchor **381** at notches **393** to collapse eyelet **387** and to bring sharpened edge **391** to cut or sever the suture positioned therethrough. In this instance, shank **389** will have been crimped over the remaining suture material and will firmly hold it. Alternatively, the crimper/fastener of FIGS. **49A–49E** may be used to achieve the same result.

FIG. **25F** shows yet another variation on anchor **395**. Anchor **395** may have a distal end which is tapered and sharpened to facilitate insertion into the tissue and a proximal end which is indented to facilitate loading of the anchor during deployment, as described further below. Eyelet **401** may be defined along the anchor body proximally of distal end **399** to provide a location for the suture or tensioning element to pass. Proximal of distal end **399**, one or several retractable arms **397** may be formed such that arms **397** are pivotable to lie against the anchor body during loading and delivery, as shown by retracted position **397'**. During deployment into the tissue, retracted arms **397'** may be configured to extend outwardly into its expanded configuration **397** such that pulling anchor **395** out of the tissue is inhibited by the extended arms **397** digging into the tissue. The diameter formed by the extended arms **397**, i.e., the expanded diameter, is preferably larger than the diameter formed by the retracted arms **397'**, i.e., the retracted diameter, such that a ratio of the expanded diameter to the retracted diameter is on the order of between about 2:1 to 50:1.

Any of the anchor variations may be optionally coated with a therapeutic agent or antimicrobial agent to facilitate healing or to effect some other results, like timed drug delivery or to act as an anti-thrombosis agent. Alternatively, a radiopaque coating layer may be coated over either one, several, or all of the anchors for deployment to facilitate visualization during deployment and/or placement using any conventional visualization techniques. The coatings may vary and may include, e.g., Nickel-Titanium alloy, Platinum, Palladium, Gold, and/or Tantalum.

FIG. **26** shows a cross-sectional superior view of, e.g., human heart section **390**, with the atrial chambers removed for clarity. Heart tissue **392** is seen surrounding tricuspid valve **400** and bicuspid or mitral valve **402**. Sectioned ascending aorta **394** and pulmonary trunk **396** are also seen as well as coronary sinus **398** partially around the periphery of heart section **390**. An example of expandable grid **360** in a deployed configuration is shown over mitral valve **402**. Grid **360** may be placed entirely over valve **402** and anchored into heart tissue **392** by anchors **404**, which may be of a type shown in FIG. **25A** or **25B**, at anchoring regions **364**. Once grid **360** is in place, it may impart a spring force

which may draw the opposing sides of valve **402** towards one another, thereby reducing or eliminating valvular regurgitation.

Another variation on a biasing clip device is shown in FIGS. **27A** and **27B**. FIG. **27A** shows circumferential clip **406** having opposing members **408**. This clip variation, preferably made of a shape memory alloy, e.g., Nickel-Titanium alloy, may be inserted into the tissue surrounding a valve. This clip may surround the periphery of the valve and provide an inwardly biased spring force provided by opposing members **408** to at least partially cinch the valve. The variation in FIG. **27A** preferably surrounds about 50% to 75% of the valve circumference. The variation of clip **410** is shown in FIG. **27B** with opposing members **412**. Here, the clip may be made to surround at least about 50% of the valve circumference. FIG. **28** again shows the cross-sectional superior view of heart section **390** except with circumferential clip **406** placed in the tissue **392** around valve **402**. As shown, opposing members **408** preferably provide the inwardly biased spring force to at least partially cinch valve **402**.

A further variation of the clip is shown generally in FIGS. **29A** and **29B**. A side view of valve clip **414** is shown in FIG. **29A** having anchoring members **416** on either end of clip **414**. FIG. **29B** is an end view of valve clip **414**. FIGS. **30A** and **30B** likewise show another variation of valve clip **418** with curved anchoring members **420** on either end of the clip. This variation of valve clip **418** shows the addition of curved central region **422** which may be located near or at the center of clip **418**. Region **422** may be incorporated to act as a stress-relieving mechanism by allowing clip **418** to bend or pivot to a greater degree about region **422** than clip **418** normally would. This may also allow for greater adjustability when placing clip **418** over a valve. FIG. **30B** shows an end view of the clip.

Another variation is seen in FIGS. **31A** to **31D**. FIG. **31A** shows a top view of arcuate valve clip **424**. Clip **424** preferably has an arcuate central member **426**, which is shown as a semicircle having a radius, R . Central member **426** may serve to act as a stress-relieving member, as described above, and it may also be designed to prevent any blockage of the valve by clip **424** itself. Thus, radius, R , is preferably large enough so that once clip **424** is placed over the valve, central member **426** lies over the valve periphery. FIG. **31B** shows a side view of the clip. This view shows anchoring members **430** attached by bridging members **428** on either end to central member **426**. FIG. **31C** shows an end view of the clip where the anchoring members **430** and central member **426** are clearly shown to lie in two different planes defining an angle, α , therebetween. The angle, α , may vary greatly and may range from about 60° to 120° , but is preferably about 90° for this variation. Finally, FIG. **31D** shows an isometric view of clip **424** where the biplanar relationship between anchoring members **430** and central member **426** can be seen.

The curved anchoring members above are shown as being curved in a semi-circle such that they face in apposition to one other. But any geometry may be used, e.g., arcs, half-ellipses, hooks, V-shapes or triangles, and generally any type of end geometry that would facilitate tissue insertion yet resist being pulled or lodged out.

The shape of the clip itself may range from a wide variety of geometries. Such geometries may include circles, semi-circles, rectangles, triangles, or any combinations thereof. FIGS. **32A** and **32B** show a top and side view, respectively, of valve clip **432a** and anchoring members **434a** where the entire clip **432a** preferably curves in an arcuate manner.

FIGS. 33A and 33B show a top and side view, respectively, of clip 432b with anchoring members 434b where clip 432b is in a triangular shape. FIGS. 34A and 34B show a top and side view, respectively, of clip 432c with anchoring members 434c where clip 432c is in a rectangular shape. FIGS. 35A and 35B show a top and side view, respectively, of clip 432d with anchoring members 434d where clip 432d is a looped section. Likewise in FIGS. 36A and 36B show a top and side view, respectively, of clip 432e with anchoring members 434e where clip 432e has a curved section, which may act as a stress-relieving member. These various clip geometries are presented as examples and in no way limit the scope of the invention.

Any of the above-described clips or any other clip geometry in the spirit of this invention may be coated with a variety of substances. For example, a clip may be coated with a hydrophilic (which may be used, e.g., for surface lubricity), anti-thrombosis agent, therapeutic agent, or any other drug coating to prevent, e.g., thrombosis, or to act as a drug delivery mechanism. Such drug coatings may be applied during the clip manufacture or just prior to deployment. Also, the clips may be made to become more radiopaque by coating them with, e.g., Nickel-Titanium alloy, Platinum, Palladium, Gold, Tantalum, or any other biocompatible radiopaque substance. Such a coating could be applied, e.g., by sputter coating or ion deposition. Moreover, the coating is preferably applied in a thin enough layer such that it would not affect the physical properties of the clip material.

The clip may be delivered and placed over or around the valve using a variety of different methods, e.g., endoscopically, laparoscopically, or through other conventional methods such as open-heart surgery. A preferable method and apparatus is to deliver the clip through the vasculature using a delivery catheter and/or guidewire. FIG. 37 shows a variation of such a catheter in the cross-sectioned view of a distal section of delivery catheter 436. Catheter body 438, which may comprise an outer layer of catheter section 436, may be comprised of a variety of materials, e.g., polyimide, polymeric polyolefins such as polyethylene and polypropylene, high density polyethylene (HDPE), etc. and is preferably lubricious to allow easy traversal of the vasculature. Catheter body 438 preferably has delivery lumen 440 defined throughout the length of catheter section 436 and may terminate at the distal tip in delivery port 442. Delivery port 442 may be an open port and it may be sealable during delivery when catheter section 436 traverses the vasculature. At the distal most end of section 436, distal tip 443 may be placed with delivery port 442 defined therethrough. Distal tip 443 may be metallic, e.g., Nickel-Titanium alloy, Platinum, Palladium, Gold, Tantalum, etc. to provide radiopacity for visualization by, e.g., a fluoroscope, CT, or PET, and is preferably rounded to be atraumatic to the vasculature. Catheter section 436 may alternatively use a radiopaque marker band (not shown) either alone or in addition to tip 443 to further aid in visualization.

Clip 444 may be disposed in lumen 440 within catheter section 436; as seen, clip 444 is preferably in a compressed configuration to fit within lumen 440 during delivery. The clip 444 may be loaded into catheter section 436 through delivery port 442, or alternatively, through the proximal end of delivery lumen 440 and advanced towards the distal end of catheter section 436. Reinforced liner 446 may surround the area where clip 444 is loaded to allow structural reinforcement to catheter body 438. Liner 446 may also allow constraint of clip 444 while allowing forward movement of the clip 444 during deployment. Liner 446 may be made

from a thin-walled superelastic or shape memory tube and may also have a lubricious coating to reduce the amount of force required for deployment of clip 444. Catheter section 436 may be guided within the vasculature via a conventional guidewire (not shown), or it may be steered through the vasculature via steering lumen 452 which may contain steerable components, e.g., wire 453, disposed within to steer catheter section 436. Wire 453 may be a pull-wire, leaf spring, or other steering-type device.

Once catheter section 436 has reached the target site, clip 444 may be advanced through delivery port 442 by plunger 448. Plunger 448 is preferably attached to a distal end of stylet 450, which may run through the full length of catheter body 438 to allow manipulation from the proximal end. Plunger 448 may be advanced towards the distal end of catheter section 436 to urge clip 444 out of delivery port 442 by manipulating the proximal end of stylet 450. Stylet 450 may be advanced manually like a guidewire, or by attaching it to an advancement mechanism, e.g., a thumb-slide. Stylet 450 may also be passed through a hemostatic valve located within catheter body 438, either at a distal or proximal end, to prevent backflow into lumen 440 during insertion and delivery through the vasculature. The advancement mechanism, discussed further below, may be controlled by an indexed linear movement mechanism, e.g., a screw, ratchet, etc., located on a handle at the proximal end of catheter body 438. Once plunger 448 and stylet 450 is advanced completely, clip 444 may be urged completely through delivery port 442, where it may then expand or form its deployed configuration.

FIG. 38 shows catheter section 436 with another compressed variation of clip 454. Here, clip 454 may be compressed into a "U" or "V" shape for delivery and deployed in the same manner by plunger 448 and stylet 450 through delivery port 442, as discussed above. This variation enables the ends of clip 454 to be deployed simultaneously; however, this variation may also require a larger delivery port 442 than the variation shown in FIG. 37.

FIG. 39 shows a further variation of the distal end of deployment catheter section 456. This variation shows catheter body 458 with delivery lumen 460 terminating in distal tip 461, much like the variations shown above. But here, distal tip 461 does not have a delivery port defined through it, rather delivery port 462 is preferably defined along a distal length of catheter body 458 proximally of distal tip 461. Clip 464 may be any of the variational shapes described above but is shown here in a compressed arcuate shape. Clip 464 may be held within catheter section 456 by an external constraining sheath or it may be held simply by friction fitting clip 464 within delivery port 462. Catheter section may be steered to the desired target site via steering lumen 468 and once in position, deployment stylet 466 may be urged towards the distal end of section 456 in much the same manner as described above. However, stylet 466 is preferably angled at its distal tip to facilitate pushing clip 464 out through delivery port 462.

FIGS. 40A and 40B show a top and side view, respectively, of an example of catheter handle 470 which may be used to advance the clip into position over a valve or opening. This variation shows handle 470 with distal end 472, where the catheter is preferably attached, and the linear advancement mechanism, shown here as thumb-slide 474. Thumb-slide 474 may be advanced in advancement slot 476 towards distal end 472 to urge the plunger and stylet. Within handle 470, the advancement of thumb-slide 474 may be controlled by an indexing mechanism, e.g., a screw, ratchet,

or some type of gear, which may allow the proximal and distal movement of the thumb-slide 474 through slot 476.

Delivering and placing the clip over the desired tissue, valve, or opening may be accomplished by several different methods. As shown in FIG. 41A, one exemplary method is to introduce deployment catheter 478 into the coronary vasculature through, e.g., the jugular vein, and into the superior vena cava SVC. From there, tricuspid valve TV may be treated or the mitral valve MV may be treated by having catheter 478 penetrate the atrial septum AS using a septostomy procedure, as discussed above. Once septum AS is perforated, catheter distal end 480 may be inserted into the left atrium LA and brought into position over the mitral valve MV. Catheter distal end 480 may be positioned over mitral valve MV by tracking its position visually through a fluoroscope or other device by using the radiopaque distal tip (as described above) or via a radiopaque marker band or half-marker band 486. As shown, distal end 480 may be brought into contact against or adjacent to one side of the annulus of tissue A. The plunger may be advanced (as described above) to then urge a first end of clip 484 out through delivery port 482 and into the annulus of tissue A.

Then, as shown in FIG. 41B, distal end 480 may be moved or steered to the opposite side of the annulus of tissue A after or while the rest of clip 484 is advanced through delivery port 482. The distal end 480 is preferably moved to the opposite side of the mitral valve MV at about 180°, if possible, from the initial contact point to allow for optimal reduction of the diameter of the valve. Once distal end 480 is positioned on the opposing side of the valve, the plunger may then be finally advanced so that the remaining second end of clip 484 exits delivery port 482 and engages the annulus of tissue A.

The variations described above may incorporate a variety of sensors or transducers in the delivery catheter to ensure adherence or optimal clip performance. For instance, as seen in FIG. 41C sensor/transducer 485, e.g., ultrasound, Doppler, electrode, pressure sensor or transducer, etc., may be incorporated into the distal end 480 of the catheter 478. Sensor/transducer 485 may be connected, electrically or otherwise, to a sensor monitor 487, which is preferably located outside the body of the patient and which may be used to record and/or monitor a variety of signals generated from sensor/transducer 485. For example, a pressure sensor may be used as sensor/transducer 485. This pressure sensor may then be used to quantify the treatment effectiveness before catheter 478 is withdrawn. In another variation, sensor/transducer 485 (in this case, used as, e.g., a transducer) may be used to deliver energy, e.g., RF, electrical, heat, etc., to enhance the treatment effectiveness, in which case monitor 487 may be an electrical or RF power source.

Distal end 480 may also incorporate a grasping and/or releasing mechanism (not shown) to aid in clip release and implantation. Such a mechanism may be incorporated on the plunger or stylet, or a separate catheter may be inserted in conjunction with catheter 478. The grasping and/or releasing mechanism may also be used to temporarily provide an electrical connection to the clip.

In a further variation for delivering and placing the clip, it may be deployed through one or more delivery ports located in the side of the catheter rather than from the distal end. Delivering from the catheter side may be accomplished in much the same manner as described for FIGS. 41A–41C above. Alternatively, a catheter may be inserted into the coronary vasculature, particularly the coronary sinus, via the aorta to deliver the clip. A cross-sectional superior view of mitral valve opening 488 of mitral valve 402 of a patient's

heart is seen in FIG. 42A. Delivery catheter 490 may be inserted into the coronary sinus 398 and positioned adjacent to mitral valve 402 such that delivery ports 492a, 492b, 492c are preferably facing in apposition to mitral valve 402. Although three delivery ports are shown in this example, one to any number of desired delivery ports may be used. Delivery ports 492a, 492b, 492c are preferably located proximally of distal end 494 and the orientation of the ports may be maintained against mitral valve 402 by the use of an orientation marker 496, which may be, e.g., a half-marker.

Once proper orientation has been determined, a first clip 498a, which may be compressed in catheter 490 may be urged out of delivery port 492a by a plunger and stylet, as described above or twisted out, and pushed through a wall of the coronary sinus 398 and through the adjacent heart tissue 392, as shown in FIG. 42B. The clips are preferably made of a superelastic or shape memory alloy, e.g., Nickel-Titanium alloy (e.g., nitinol), and are preferably made to expand as it exits catheter 490. Accordingly, clip 498a may be pushed until the farthest anchoring member of clip 498a is in contact with and enters the edge of valve 402 farthest from catheter 490. As clip 498a finally exits delivery port 492a, the anchoring member may exit and then engage the edge of valve 402 closest to catheter 490. This procedure may be repeated for several clips, as seen in FIG. 42C, where first and second clip 498a, 498b, respectively, are shown to have already exited and engaged the tissue surrounding valve 402. FIG. 42D shows the final engagement of third clip 498c having exited delivery port 492c and engaged the tissue surrounding valve 402. Once the clips are in place, the compressive spring force of the clips may aid in drawing the opposing sides of valve 402 together, thereby drawing or cinching opening 488 close and reducing or eliminating the occurrence of valvular regurgitation through the valve. The use of three clips is merely exemplary and any number of desired or necessary clips may be used.

FIGS. 43A and 43B show the valve of FIGS. 42A–42D and a side view of the valve, respectively. FIG. 43A shows another example of arcuate clips 500a, 500b, as described in FIGS. 31A–31D, engaged to mitral valve 402. Arcuate clips 500a, 500b are designed such that the curved region of each clip is preferably opposite to each other in order to keep opening 488 unobstructed. FIG. 43B shows a side view of valve 402 in annulus 502. Clips 500a, 500b are preferably engaged to the tissue surrounding annulus 502, e.g., to annulus walls 504.

Aside from the use of clips to engage the valve tissue, indented anchor 395, as shown above in FIGS. 25F, may alternatively be used to reduce the diameter and thereby the regurgitation across the valve. FIG. 44A shows one example for using deploying anchors 395 as an alternative variation to the approximation devices described above. The cross-sectional superior view of heart section 390 is shown again with the atrial chambers removed for clarity. Heart tissue 392 is seen surrounding tricuspid valve 400 and bicuspid or mitral valve 402. In this example, delivery catheter 508 may be used, through any of the delivery methods described above, to position delivery port 510 of the catheter 508 proximate to, e.g., mitral valve 402. Catheter 508 may be used to selectively position a number of anchors 395 around the perimeter of valve 402. The optimal number of anchors 395 used may depend upon the size of the valve to be approximated and/or the desired resulting approximation effects.

The anchors 395 may be pre-threaded with a suture 506 or other tensioning element, e.g., a wire, prior to loading or delivery into tissue 392. Alternatively, anchors 395 may be

first placed into tissue 392 and subsequently threaded with suture 506. In either case, suture 506 is preferably positioned such that it surrounds the periphery of the valve 402, as shown. After the individual anchors 395 are positioned around the valve 402, suture 506 may be tightened by pulling on the proximal end of suture 506 through catheter 508 and drawing suture 506 through a crimp or other adjustable fastener. This tightening will approximate the opposing sides of valve 402 to draw or close the opening of valve 402. Once the desired degree of approximation has been effected, suture 506 may be cut by crimping one of the anchors 395, as described above, or by severing suture 506 with a crimp adapted to cut suture 506, and the tools may be removed from the region.

FIG. 44B shows the deployed anchors 395 surrounding valve 402 with suture 506 forming a closed loop and having been tightened to approximate the valve leaflets. Crimp or fastener 507 is shown as maintaining the tension across suture 506 and valve 402 with the excess suture and deployment catheter 508 having been removed from the area.

FIG. 45 shows another variation in the deployment of anchors 395 to reduce the diameter of, in this example, valve 402. In this example, anchors 395 may be deployed and positioned within the coronary sinus 398 around the periphery of where mitral valve 402 is located. Suture 506 may be tied or affixed to one of the terminally located anchors 395' or 395" and suture 506 may be tightened through the remaining anchors 395. This tightening of suture 506 draws the tissue 392 together, which in turn approximates the leaflets of valve 402. This method eliminates the need to enter within the heart and also eliminates the need to form a looped suture 506. A crimper/fastener 507 may alternatively be used to tighten the suture against the proximal terminating anchor 395'.

FIG. 46A shows a cross-sectional side view of one variation of a delivery catheter for delivering and implanting anchors 381 of FIG. 25D. Delivery catheter 508 in this particular variation may comprise an outer delivery member which defines delivery port 510 at its distal end through which anchors 381 may be delivered. Catheter 508 may have a diameter ranging from 3–5 mm and may be any variety of intraluminal vascular catheter suitable for such an application. It may also be a steerable catheter which may be selectively maneuvered via a pull wire, as appreciated by one of skill in the art. Within the lumen of catheter 508, a separate cartridge/pusher 512 may be slidably disposed and adapted to hold the individual anchors 381 in a linear tip-to-tail configuration, as described above and as shown in the figure. The distal end of cartridge 512 may be enclosed by release port 516, which may be adapted to selectively hold anchors 381 within cartridge 512 until plunger 514 is actuated via actuator 518, e.g., which can be a pneumatically, electrically, or electromagnetically driven pusher, as known in the art, which may be manipulated by the surgeon to push a selective number of anchors 381 out of cartridge 512. After an anchor 381 has been ejected from cartridge 512, release port 516 closes behind anchor 381 to leave anchor 381 within the space between cartridge 512 and delivery port 510. Cartridge 512 may then be actuated by the surgeon to move distally to push anchor 381 beyond port 510 and into the tissue.

When the anchors 381 are loaded within cartridge 512, the tensioning element or suture 506 is preferably pre-threaded through anchors 381. The suture 506 is threaded through the first anchor 381 and through each successive anchor 382 until it is threaded through the last one. Then the suture is threaded alongside anchors 381 and brought back to

approximate the other end of the suture 506 to form a loop. The two suture ends are threaded through fastener 507 for final tightening/crimping and cutting.

FIG. 46B shows an end view of the catheter 508 from FIG. 46A. As seen, release port 516 may be configured in one variation as a leaf valve 520 which is adapted to hold anchors 381 within catheter 508 until they are actively and selectively ejected via the cartridge/pusher 512. The leaf valves 520 can bend outwardly towards delivery port 510 but not inwardly into cartridge/pusher 512. This effect allows cartridge/pusher 512 to force the anchors 381 out of the delivery port 510 and into the tissue. FIG. 46C shows a cross-sectional view of another variation of an integral catheter body 522. Within this variation, anchors 381 may be disposed within cartridge lumen 524 and the tensioning element or suture may be disposed within one or both of working lumens 526.

FIG. 47 shows a cross-sectional side view of another variation of a delivery catheter for delivering and implanting anchors 395 of FIG. 25F. As seen, anchors 395 may be positioned within cartridge/pusher 512, which itself resides slidably within delivery catheter 508. Retracted arms 397' are shown in their retracted state while positioned within cartridge/pusher 512 and delivery catheter 508. Suture 506 is shown passing through each of the eyelets of anchors 395 and looping through the first anchor 395 positioned by delivery port 510 to be looped back towards the proximal end of delivery catheter 508, where the terminal ends of suture 506 may be passed through crimp or fastener 507. In use, anchors 395 may be deployed in the same manner. Actuator 518 may be actuated to push an anchor 395 out of cartridge 512 and proximal to port 510. When ready for deployment into the tissue, anchor 395 may be pushed via cartridge 512 to eject anchor 395 out of catheter 508.

FIG. 48 shows an isometric view of one variation of cartridge/pusher 512 removed from catheter 508. As shown, cartridge 512 may define a pushing surface 528 where anchors may be pushed with cartridge/pusher 512. Along the length of the body of cartridge 512, a narrow slot or channel 530 may be defined to allow suture 506 and/or crimp or fastener 507 to pass through.

FIG. 49A shows an isometric view of one variation of crimp or fastener 532 which may be used to maintain the tension within the suture after the valve tissue has been approximated. This variation may define a fastener body with a channel 536 defined therethrough within which suture 506 may pass freely. One end of channel 536 may have a sharpened edge or blade 534 which may be positioned at least partially around the perimeter of channel 536 such that crimping fastener 532 will cause edge 534 to collapse into channel 536 and sever suture 506.

Although fastener 532 may be configured to allow suture 506 to pass freely therethrough, fastener 532 is preferably designed to allow for the unidirectional travel of suture 506 through the fastener 532. This allows suture 506 to be tightened through the anchors but prevents suture 506 from slipping back and releasing the tension within the anchors and the valve tissue. FIGS. 49B–49E show various alternative designs which allow for the uni-directional tensioning of suture 506. FIG. 49B shows a cross-sectional side view of one variation of fastener 538 in which tension is maintained within suture 506 via ratchet 542. As fastener 538 is passed over suture 506 through channel 540 (fastener 538 moves from left to right), ratchet 542 allows suture 506 to pass freely yet remains in contact due to the biasing force of spring element 546. However, when suture 506 slips in the opposite direction, ratchet 542 rotates about pivot 544 and is

stopped by stop 548. The edge of ratchet 542 effectively digs into suture 506 to stop the reverse movement of suture 506 (and to stop de-tensioning from occurring). After suture 506 has been desirably tightened, fastener 538 may be crimped along where blade 550 is positioned to bring blade 550 against suture 506 to sever it from the deployed anchors.

FIG. 49C shows a cross-sectional side view of another variation of fastener 552. In this variation, ratchet 554 may be formed integrally within fastener 552 housing. A roughened suture 506' is preferably used to present a roughened surface to ratchet 554. This variation operates similarly to the variation above, but is simpler in construction and operates in much the same manner as a zip-tie. As suture 506' is passed through the fastener channel 556, the angle of ratchet 554 allows for the uni-directional travel of suture 506' from right to left. If pulled in the opposite direction, ratchet 554 digs into the roughened surface and prevents the reverse movement of suture 506'. After suture 506' has been desirably tensioned, fastener 552 may be crimped to sever suture 506' with blade 558.

FIG. 49D shows yet another variation of fastener 560 which is similar to the variation of FIG. 49B. As shown, ratchet 542 may rotate about pivot 544 while remaining in contact with suture 506 due to the biasing force of spring element 546. The rotation of ratchet 542 is limited by stop 548, which enables ratchet 542 to press suture 506 against housing 560, thereby stopping the movement of fastener 560 relative to suture 506. FIG. 49E shows another variation for fastener 562 which utilizes roughened or beaded suture 506". Suture 506" preferably defines a plurality of beaded elements periodically along its length. Ratchet 566 is configured such that it may open in one direction, thereby allowing the passage of suture 506" through, yet movement of suture 506" in the opposite direction forces ratchet 566 to close due to the biasing force of biasing spring element 568. Ratchet 566 is preferably configured such that suture 506" may pass through in the reverse direction, but because of beaded elements 564, further slippage of suture 506" is prevented.

Any of the fastening devices described above may be made of biocompatible metals, e.g., stainless steel, nickel and/or titanium alloys, etc., or they may be manufactured from biocompatible plastics, e.g., PTFE, etc.

Some of the fasteners above incorporated a tapered or sharpened edge to sever the suture when completely tightened. An alternative design is shown in FIG. 50, which uses a heating element to sever the tightening element or suture. This particular severing design may be used with the fasteners of FIGS. 49D and 49E, which are made without the sharpened edge. This variation may have conductive wires 574 positioned within the length of delivery catheter body 570 within separate insulating lumens. A portion 576 of conductive wires 574 may be looped within delivery lumen 572 to surround suture 506. After the tightening of suture 506 has been accomplished, portion 576 may be heated to melt and subsequently sever suture 506 where in contact to effectively release the anchors and tensioned suture without the use of a sharpened edge or blade.

In addition to the fastening elements, the anchoring elements may be further modified. FIG. 51 shows another variation of anchor 578 which may have an obturator 582 removably positionable within lumen 580 of anchor 578. Eyelet 579 may be seen defined within the body of anchor 578 for the passage of the tensioning element therethrough. To insert anchor 578 within the tissue, obturator 582 may be positioned within lumen 580 to facilitate piercing and positioning of the anchor within the tissue. When desirably

positioned, obturator 582 may then be removed leaving anchor 578 implanted within the tissue. This may be desirable since no sharpened objects are left remaining within the tissue.

FIGS. 52A–52C show side and cross-sectional views of a rotatable anchor 584 which facilitates placement of the sutures around the valve 402. This variation has anchor body 586 which houses rotatable portion 588 within. Rotatable portion 588 preferably has eyelet 590 defined therethrough. The head of rotatable portion 588 sits atop rotational shaft 592 which preferably has one or several grooves 594 defined thereon to receiveably mate with keyed portions 594 defined within anchor body 586. Keyed portions 594 are configured to interfit with grooves 596 to allow the free rotation of portion 588 within body 586 while preventing portion 588 from being removed. The rotational configuration prevents the tensioning element from wrapping about the anchor during the tensioning procedure.

Another alternative anchor mechanism is shown in FIGS. 53A and 53B. FIG. 53A shows an undeployed anchor 598 which is formed from at least two members 600, 602 interconnected via biasing element 604, e.g., a spring. Biasing element 604 may be pretensioned to deploy members 600, 602 from a straightened configuration, as in FIG. 53A, to a deployed criss-cross configuration, as shown in FIG. 53B, upon removal of a constraining force, e.g., such as when deployed from the delivery catheter. Members 600, 602 may be inserted within the tissue and then released such that it reconfigures itself and thereby anchors within the tissue. A suture or tensioning element may be threaded, e.g., via eyelet 601, through one or both members 600, 602 to effect the tensioning and approximation of valve tissue.

FIG. 54 shows yet another alternative for anchor mechanism in anchor 606. This variation is similar to those shown above, particularly in FIG. 25F; however, piercing tip 610 is made from a bioabsorbable material and is separately attachable to body 608. Tip 610 is preferably attached distally of retractable arms 612 such that after insertion within the tissue, tip 610 may be absorbed within the tissue leaving body 608 implanted anchored via arms 612. Because the piercing tip 610 is absorbed, the number of sharp objects left within the tissue is reduced or eliminated.

All of the above mentioned methods and apparatus may be delivered not only intravascularly through catheters, but also through conventional procedures such as open-heart surgery. Moreover, all of the above mentioned methods and apparatus may also be used in conjunction with flow-indicating systems, including, for example, color Doppler flow echocardiography, MRI flow imaging systems, or laser Doppler flow meters. Application of energy from the end effector may be selected such that regurgitation stops before the procedure is completed, as verified by the flow-indicating system. Alternatively, the procedure may be "overdone" to compensate for expected tissue relapse, without compromising the ultimate outcome of the procedure.

Additionally, all of the foregoing apparatus and methods optionally may be used in conjunction with ECG gating, thereby ensuring that tissue is at a specified point in the cardiac cycle before energy is deposited into the tissue. ECG gating is expected to make treatment more reproducible and safer for the patient.

Although preferred illustrative embodiments of the present invention are described above, it will be evident to one skilled in the art that various changes and modifications may be made without departing from the invention. For instance, variations of the present invention may be used as permanent or temporary localized tissue retracting devices.

Moreover, modified variations may also be used to mechanically expand or dilate tissue, e.g., for use in maintaining open nasal passages. It is intended in the appended claims to cover all such changes and modifications that fall within the true spirit and scope of the invention.

I claim:

1. An assembly for treating tissue near a valve to modify flow through the valve, comprising:

a plurality of anchor members each having a distal end adapted for insertion into the tissue surrounding the valve and a proximal end defining an opening there-through; and

a tensioning element for passage through each opening of the plurality of anchor members,

wherein the plurality of anchor members is aligned sequentially within a catheter whereby each anchor member is deployed sequentially with the tensioning element into the tissue through the catheter.

2. The assembly of claim **1** wherein the distal end of each of the anchor members is barbed.

3. The assembly of claim **1** wherein the proximal end of each of the anchor members is indented.

4. The assembly of claim **1** wherein the anchor members each define at least one notch along a length of the member adjacent to the opening.

5. The assembly of claim **1** wherein the anchor members each define a sharpened edge at least partially around the opening.

6. The assembly of claim **1** wherein the distal end of the anchor members is bioabsorbable.

7. The assembly of claim **1** wherein the distal end of the anchor members is rotatable relative to the proximal end of the anchor members.

8. The assembly of claim **1** wherein the anchor members each define at least one retractable arm which is adapted to pivot radially when deployed from the catheter.

9. The assembly of claim **8** wherein a ratio of a diameter of the deployed anchor member to a diameter of the anchor member is between about 2:1 to 50:1.

10. The assembly of claim **1** wherein the catheter further comprises an elongate cartridge therewithin, the cartridge having a proximal end, a distal end, and a length therebetween and adapted to deliver and deploy the plurality of anchor members.

11. The assembly of claim **10** wherein the plurality of anchor members is disposed longitudinally adjacent to one another within the cartridge.

12. The assembly of claim **10** wherein the cartridge further comprises a release port at the distal end of the cartridge, the release port being adapted to deploy a single anchor member at a time.

13. The assembly of claim **10** wherein the cartridge further defines a pushing surface at the distal end which is adapted to deploy the anchor members.

14. The assembly of claim **10** wherein the cartridge defines a longitudinal slot formed along the length of the cartridge.

15. The assembly of claim **1** further comprising a fastener adapted to maintain a tensile force within the tensioning element.

16. The assembly of claim **15** wherein the fastener is adapted to allow unidirectional tensioning within the tensioning element.

17. The assembly of claim **15** wherein the fastener comprises a ratchet biased to remain in contact with the tensioning element.

18. The assembly of claim **1** further comprising a heating element in selective contact with a portion of the tensioning element for severing the tensioning element.

19. The assembly of claim **1** wherein the tensioning element comprises a suture or a wire.

20. The assembly of claim **1** wherein each of the anchor members is at least partially coated with a coating layer.

21. The assembly of claim **20** wherein the coating layer comprises a therapeutic or antimicrobial agent.

22. The assembly of claim **20** wherein the coating layer comprises a radiopaque layer.

23. The assembly of claim **22** wherein the radiopaque layer is selected from the group consisting of Nickel-Titanium alloy, Platinum, Palladium, Gold, and Tantalum.

24. A method of treating tissue near a valve to modify flow through the valve, comprising:

advancing a catheter to the tissue near the valve;

deploying a plurality of anchor members from a distal end of the catheter selectively around a perimeter of the valve, each of the anchor members being connected sequentially via a tensioning element passed through an opening defined in each member;

tightening the tensioning element such that the perimeter of the valve is approximated towards one another; and securing the tensioning element such that the perimeter of the valve remains approximated.

25. The method of claim **24** wherein advancing the catheter comprises intralumenally advancing the catheter to the valve.

26. The method of claim **25** wherein advancing the catheter comprises intralumenally advancing the catheter into a heart.

27. The method of claim **24** wherein deploying the plurality of anchor members comprises sequentially advancing each of the anchor members from the catheter distal end via an actuator.

28. The method of claim **24** wherein tightening the tensioning element comprises pulling the tensioning element from a proximal end of the element.

29. The method of claim **24** further comprising severing the tensioning element.

* * * * *