



US007178184B2

(12) **United States Patent**
Flannery et al.

(10) **Patent No.:** **US 7,178,184 B2**
(45) **Date of Patent:** ***Feb. 20, 2007**

- (54) **MATTRESS HUGGING BED RAIL**
- (75) Inventors: **Mark A. Flannery**, 3021 Harbor La. North, Suite 208, Shorewood, MN (US) 55447; **Nathan A Dusheck**, Hammond, WI (US)
- (73) Assignee: **Mark A. Flannery**, Lakeville, MN (US)

1,066,976 A	7/1913	Atkinson
2,611,909 A	9/1952	Dillon et al.
2,649,594 A	8/1953	Herz et al.
2,722,693 A	11/1955	Wolf
2,751,608 A	6/1956	Lucas
2,763,014 A	9/1956	Luger
3,474,473 A	10/1969	Hannaberg

(*) Notice: Subject to any disclaimer, the term of this patent is extended or adjusted under 35 U.S.C. 154(b) by 0 days.

This patent is subject to a terminal disclaimer.

(Continued)

FOREIGN PATENT DOCUMENTS

GB 2 070 921 A 9/1981

(Continued)

Primary Examiner—Robert G. Santos

- (21) Appl. No.: **11/243,899**
- (22) Filed: **Oct. 4, 2005**

(65) **Prior Publication Data**

US 2006/0026759 A1 Feb. 9, 2006

Related U.S. Application Data

- (63) Continuation of application No. 10/652,296, filed on Aug. 29, 2003, now Pat. No. 6,952,846.
- (60) Provisional application No. 60/407,369, filed on Aug. 30, 2002.

- (51) **Int. Cl.**
A47C 21/08 (2006.01)
- (52) **U.S. Cl.** **5/425; 5/426; 5/430; 5/662**
- (58) **Field of Classification Search** **5/424-428, 5/430, 503.1, 504.1, 505.1, 658, 659, 662, 5/663**

See application file for complete search history.

(56) **References Cited**

U.S. PATENT DOCUMENTS

329,663 A 11/1885 McMurray

(57) **ABSTRACT**

A bed rail structured to minimize the gap between the mattress and the bed rail and including a leg portion and a rail portion. The rail portion extends upwardly on a first side of the mattress to extend beyond the sleeping surface of the mattress and prevent a person from rolling out of bed. The leg portion is sandwiched between the mattress and the box spring and extends toward a second side of the mattress. In one embodiment, the leg portion includes a distal end that is engaged to the second side of at least one of the mattress and box spring such that the distal end and rail portion hug the mattress. In another embodiment, the bed rail includes a relatively rigid cover depending from an upper portion of the rail portion to the sleeping surface so as to cover a gap that may exist between the first side of the mattress and the rail portion. In still another embodiment, the rail portion is set at an acute angle relative to the leg portion so as to tend to close off any gap between the first side of the mattress and the rail portion.

16 Claims, 20 Drawing Sheets

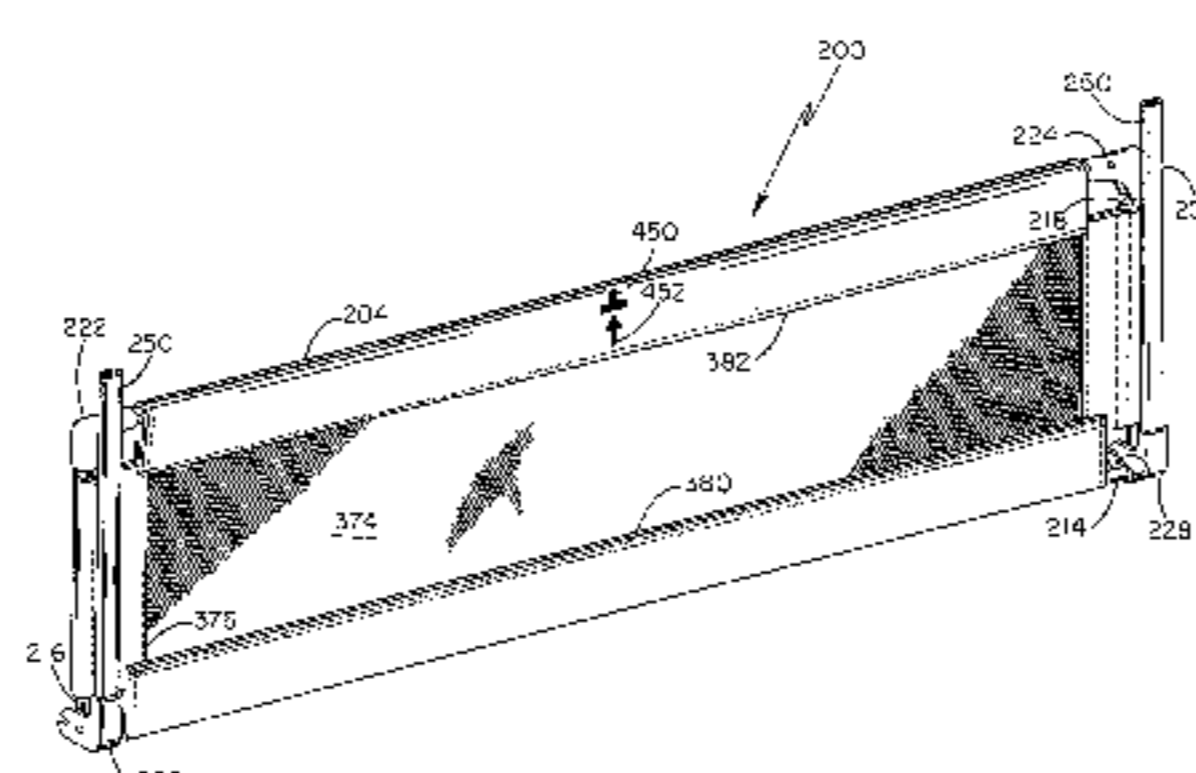
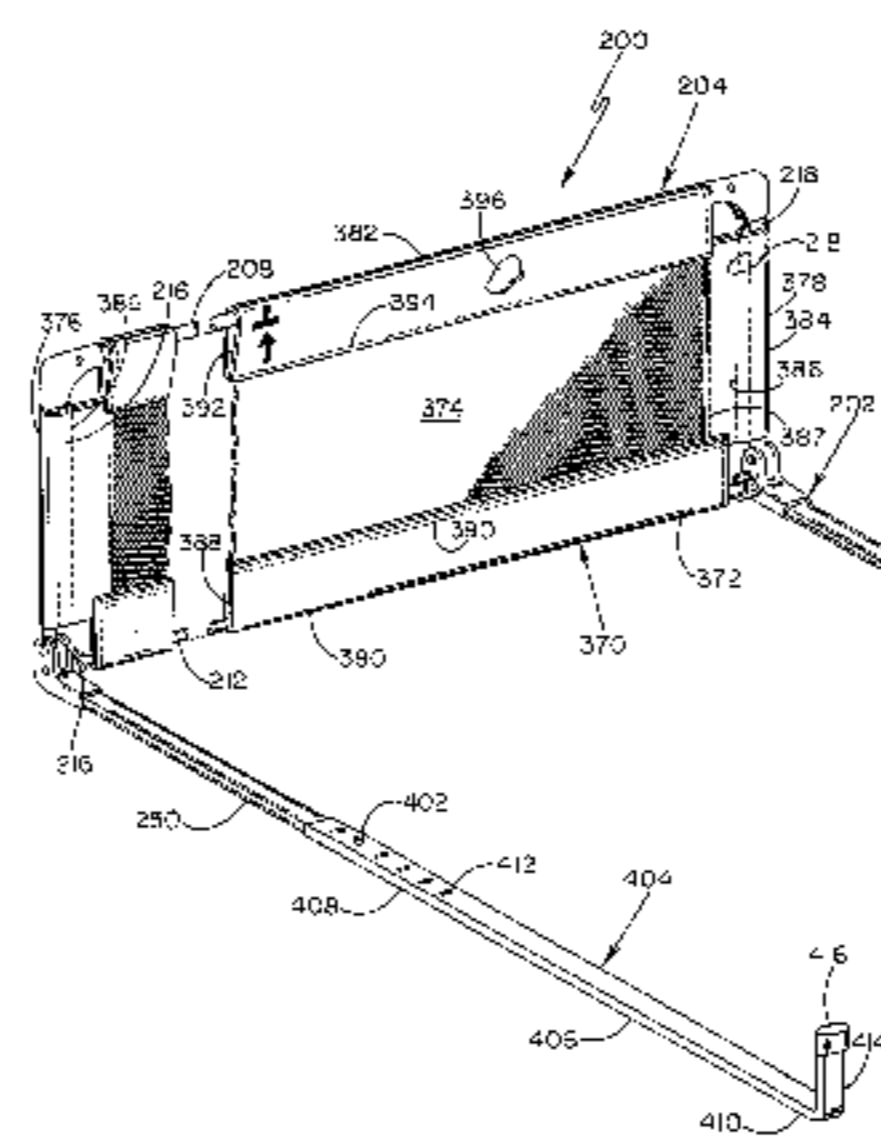

US 7,178,184 B2

Page 2

U.S. PATENT DOCUMENTS

4,833,743 A 5/1989 Howell et al.
 5,437,067 A 8/1995 Bernstein et al.
 5,519,905 A 5/1996 Bernstein et al.
 5,596,776 A 1/1997 Huang
 5,640,726 A 6/1997 Fichner-Rathus
 5,671,490 A 9/1997 Wu
 5,761,756 A 6/1998 Nowak et al.
 5,781,945 A 7/1998 Scherer et al.
 5,845,349 A * 12/1998 Tharalson et al. 5/99.1
 6,112,347 A * 9/2000 Tharalson et al. 5/95
 6,134,731 A 10/2000 Thom et al.
 6,148,456 A * 11/2000 Tharalson et al. 5/99.1
 6,202,228 B1 * 3/2001 Cox 5/95
 6,289,539 B1 9/2001 Alpern
 6,401,280 B1 6/2002 Baker
 6,453,490 B1 9/2002 Cardinale
 6,550,082 B2 * 4/2003 Tharalson et al. 5/95
 6,578,211 B2 * 6/2003 Tharalson et al. 5/93.2
 6,704,949 B2 * 3/2004 Waldman et al. 5/93.1
 6,725,476 B2 4/2004 Macari
 6,728,981 B1 5/2004 Gutierrez
 6,862,757 B2 * 3/2005 Andriunas et al. 5/95
 6,877,173 B2 * 4/2005 Tharalson et al. 5/93.2
 6,931,677 B2 * 8/2005 Tharalson et al. 5/95
 6,934,981 B2 * 8/2005 Waldman et al. 5/95
 6,952,846 B2 * 10/2005 Flannery et al. 5/425
 6,952,847 B1 10/2005 Cleary
 6,959,463 B2 * 11/2005 Macari 5/425
 6,990,697 B1 1/2006 Clute
 7,013,508 B2 3/2006 Wu
 7,024,708 B2 4/2006 Tomas et al.

7,028,353 B2 4/2006 Waldman et al.
 7,028,354 B2 4/2006 Nygren et al.
 7,055,193 B2 6/2006 Macari et al.
 7,080,419 B2 7/2006 Macari
 2002/0083524 A1 * 7/2002 Tharalson et al. 5/95
 2002/0152550 A1 * 10/2002 Tharalson et al. 5/95
 2003/0126681 A1 * 7/2003 Tharalson et al. 5/93.2
 2003/0177574 A1 * 9/2003 Waldman 5/93.1
 2003/0196264 A1 * 10/2003 Tharalson et al. 5/95
 2004/0040089 A1 3/2004 Flannery et al.
 2004/0049849 A1 3/2004 Macari
 2004/0154100 A1 8/2004 Macari
 2004/0168251 A1 9/2004 Waldman et al.
 2004/0181873 A1 * 9/2004 Waldman et al. 5/95
 2004/0187209 A1 9/2004 Flannery et al.
 2004/0250347 A1 12/2004 Brewin et al.
 2005/0034232 A1 * 2/2005 Martin 5/95
 2005/0198734 A1 * 9/2005 Macari 5/426
 2005/0229309 A1 10/2005 Nygren et al.
 2005/0229310 A1 * 10/2005 Flannery et al. 5/430
 2005/0235419 A1 * 10/2005 Macari 5/426
 2005/0246837 A1 * 11/2005 Macari et al. 5/426
 2005/0262632 A1 12/2005 Wu
 2006/0026759 A1 2/2006 Flannery et al.
 2006/0037140 A1 2/2006 Clute
 2006/0130233 A1 6/2006 Macari et al.
 2006/0150329 A1 7/2006 Nygren et al.
 2006/0162075 A1 * 7/2006 Waldman et al. 5/426

FOREIGN PATENT DOCUMENTS

GB 2 225 716 A 6/1990

* cited by examiner

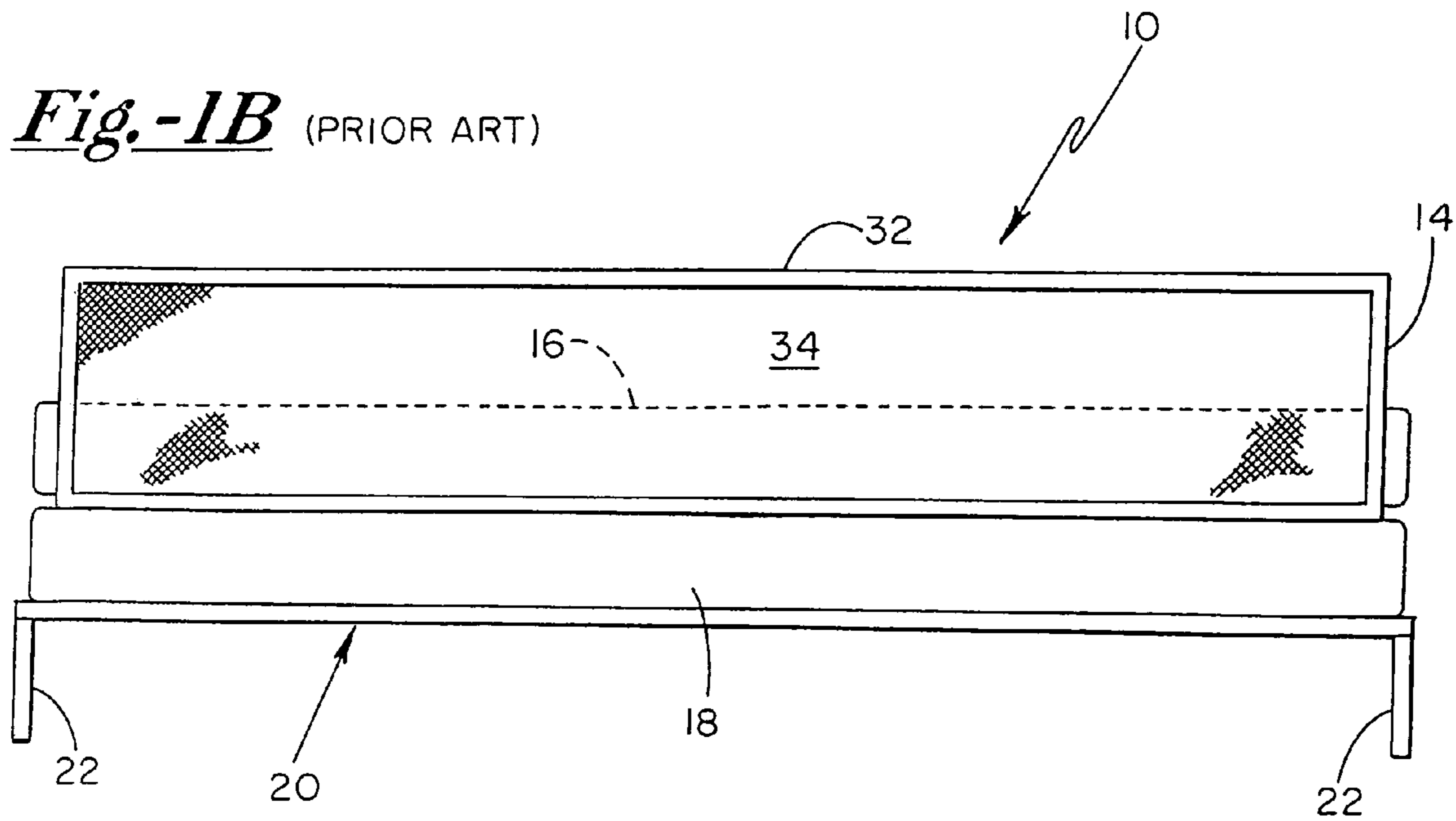
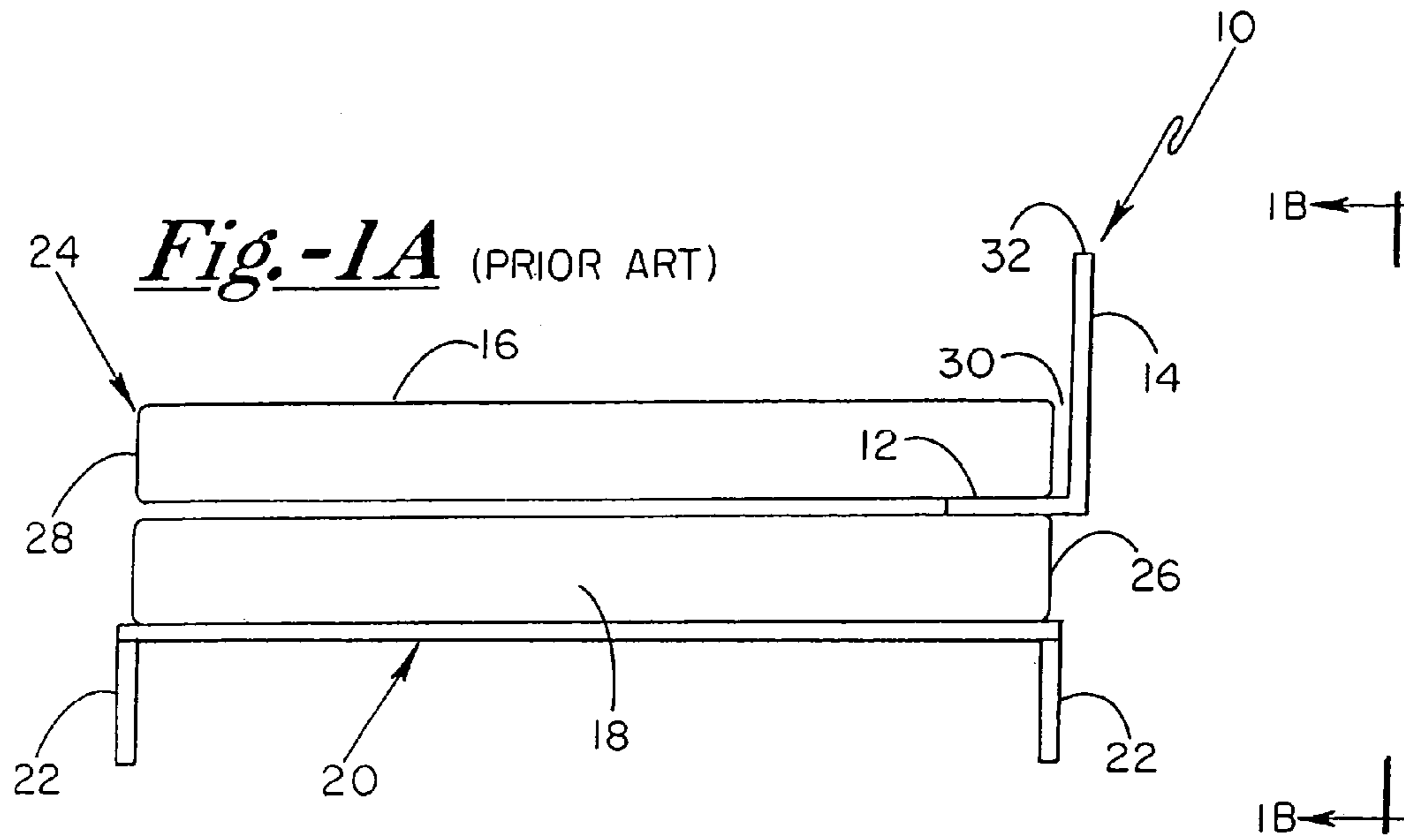

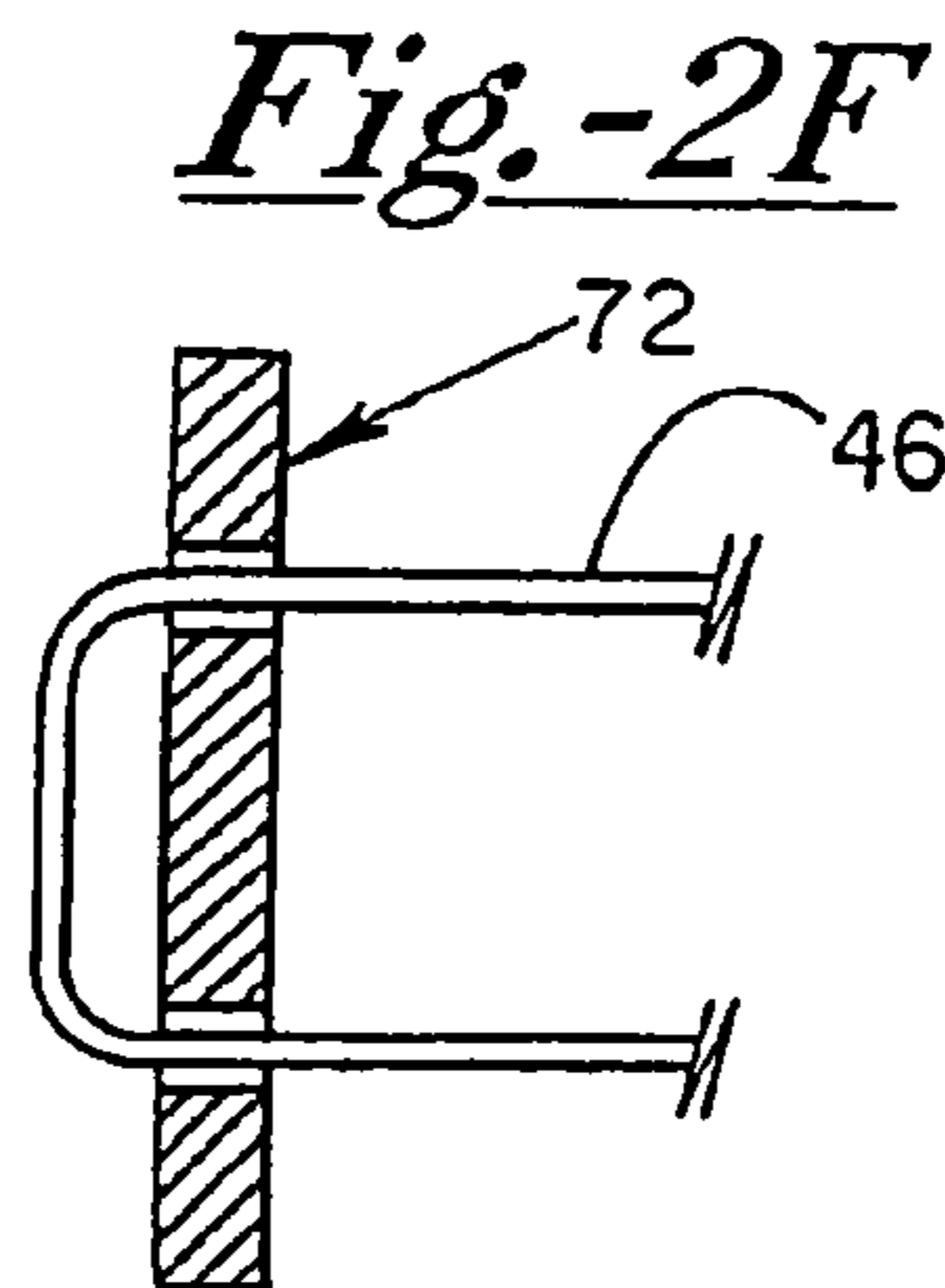
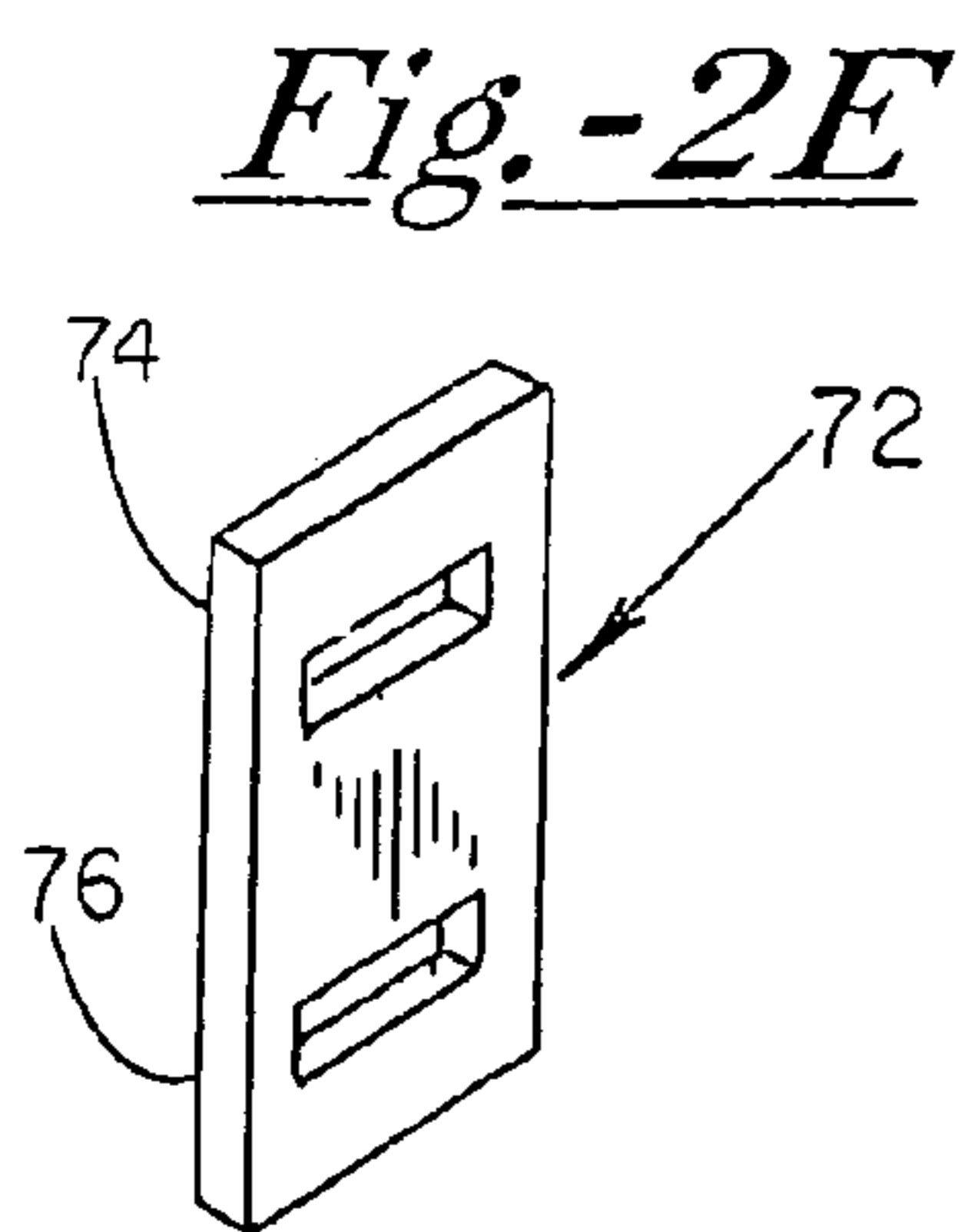
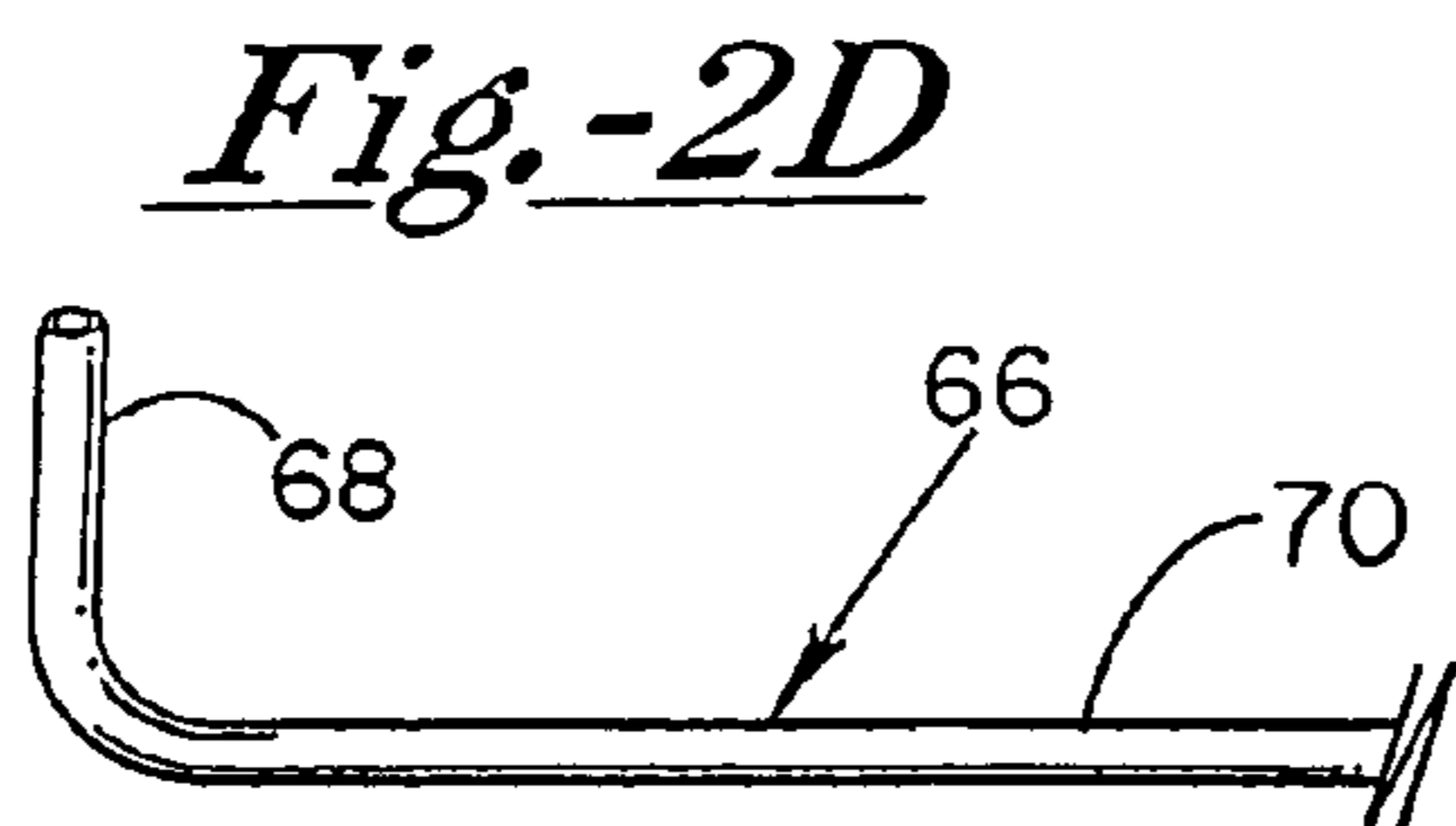
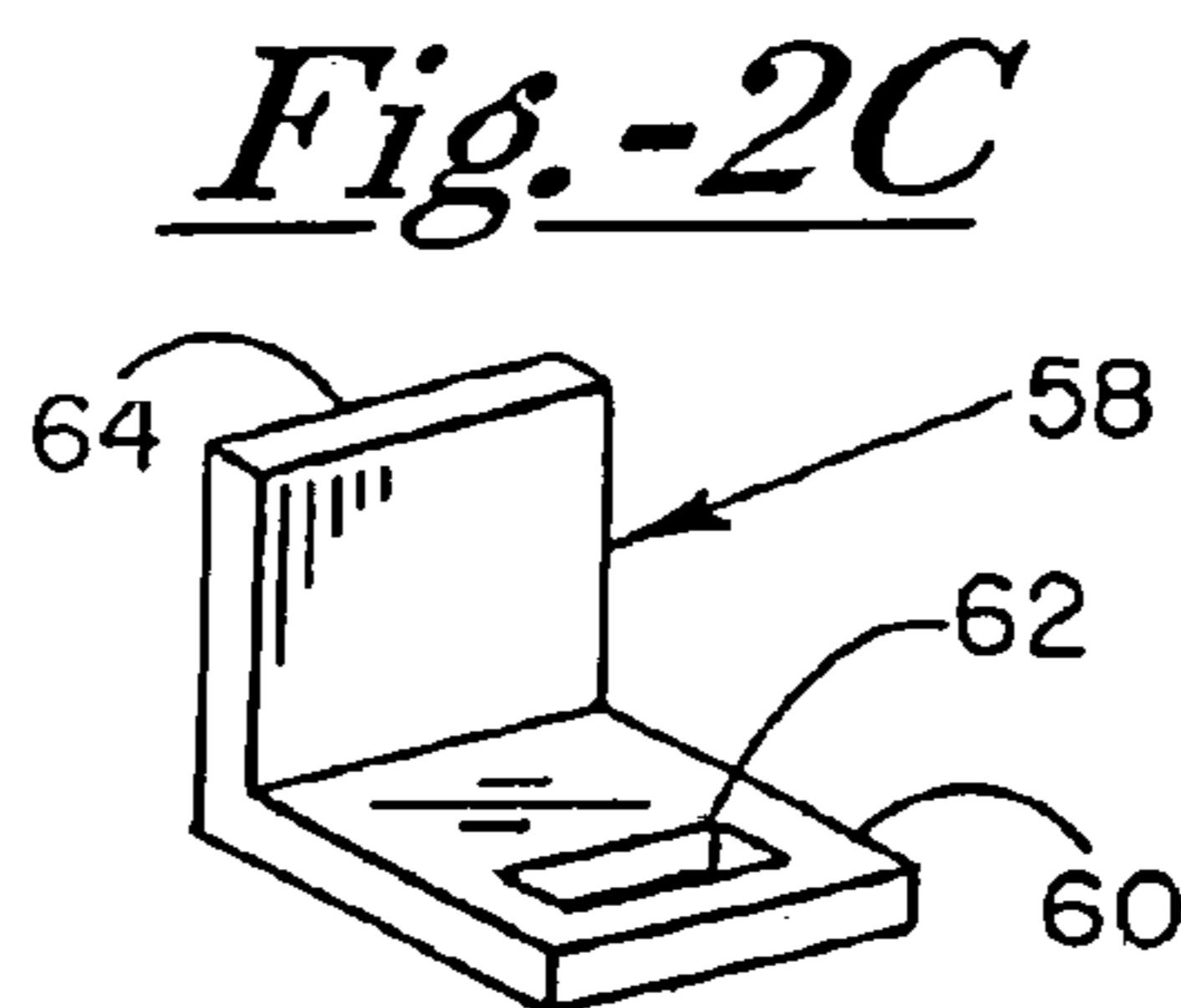
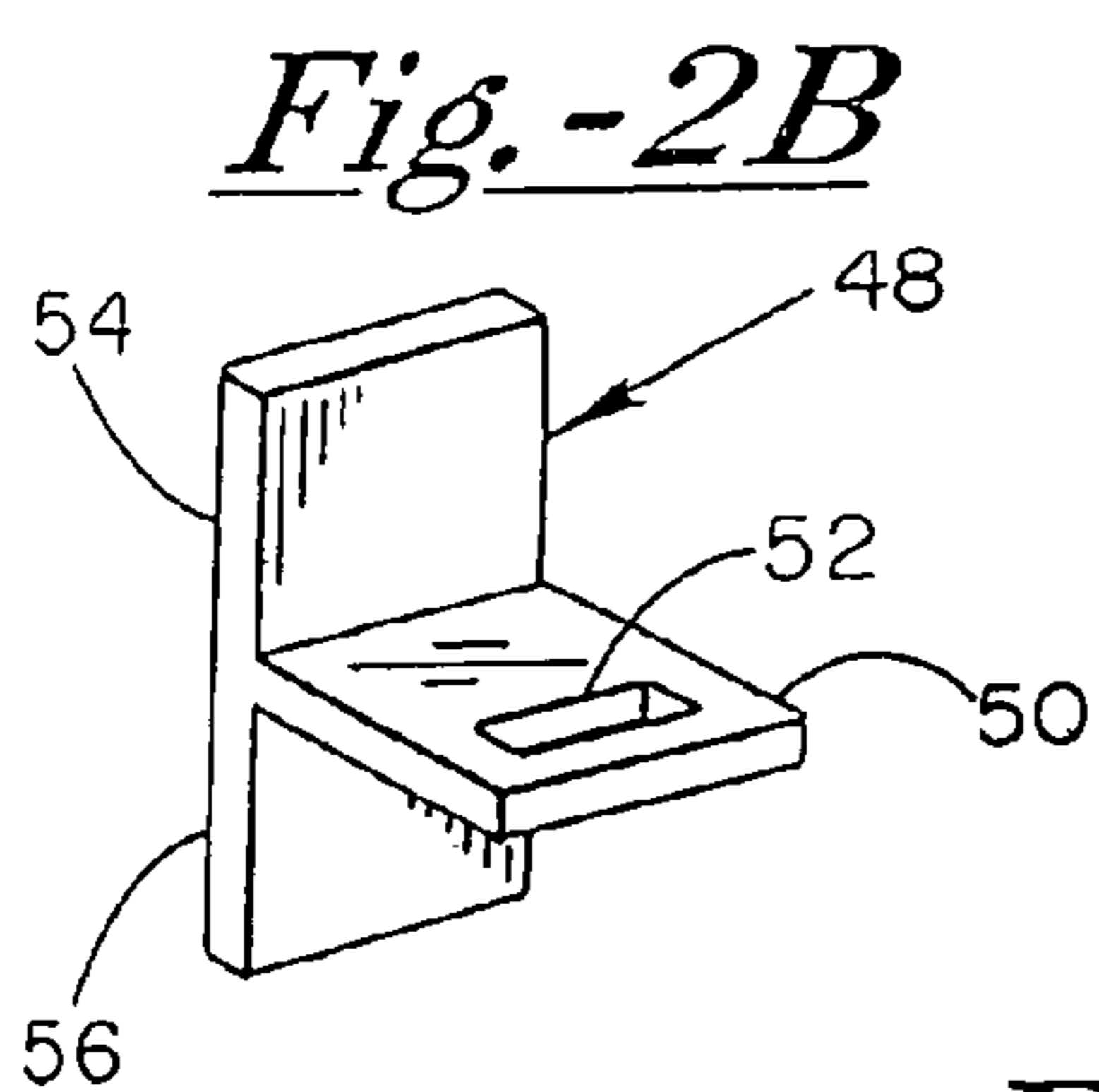
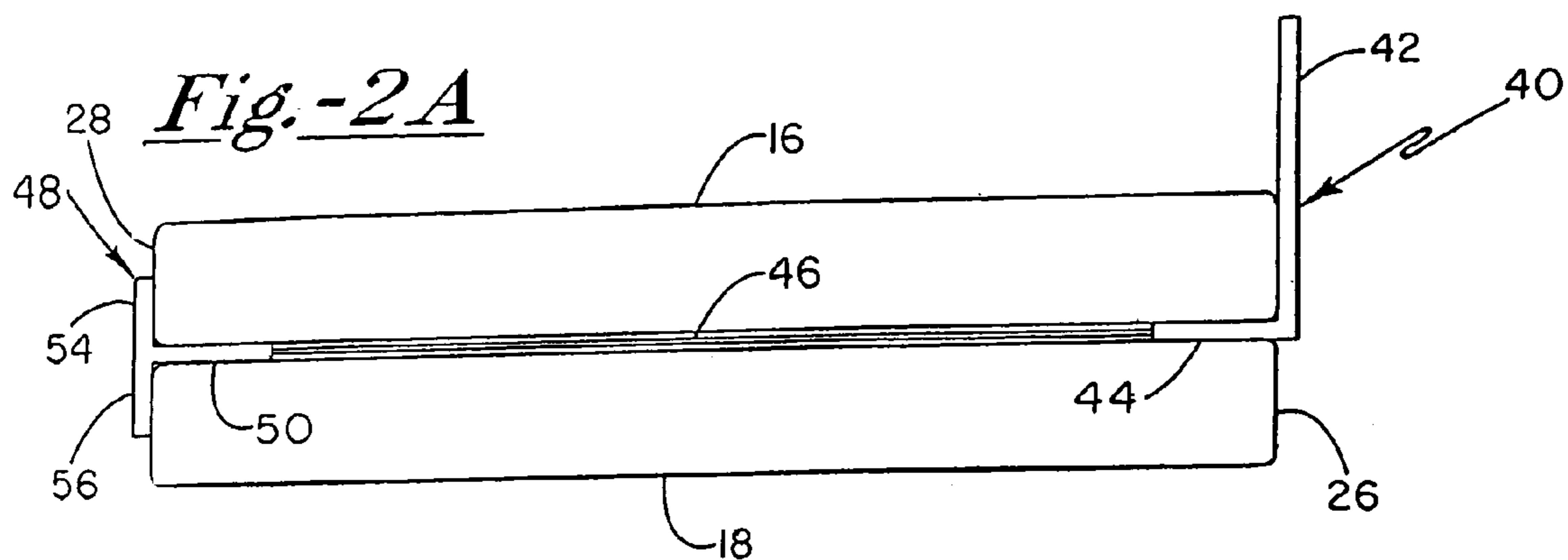

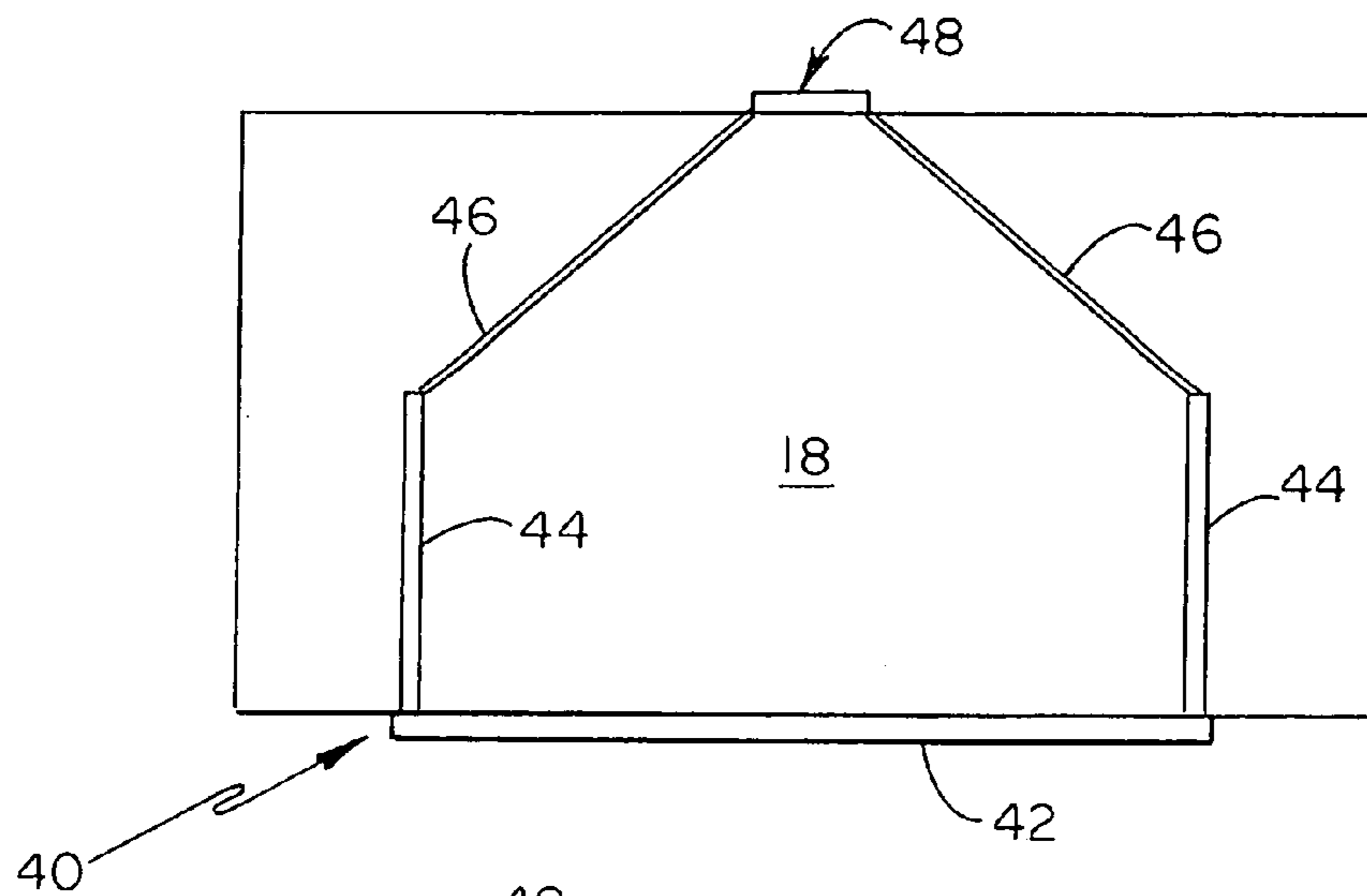

Fig.-3A

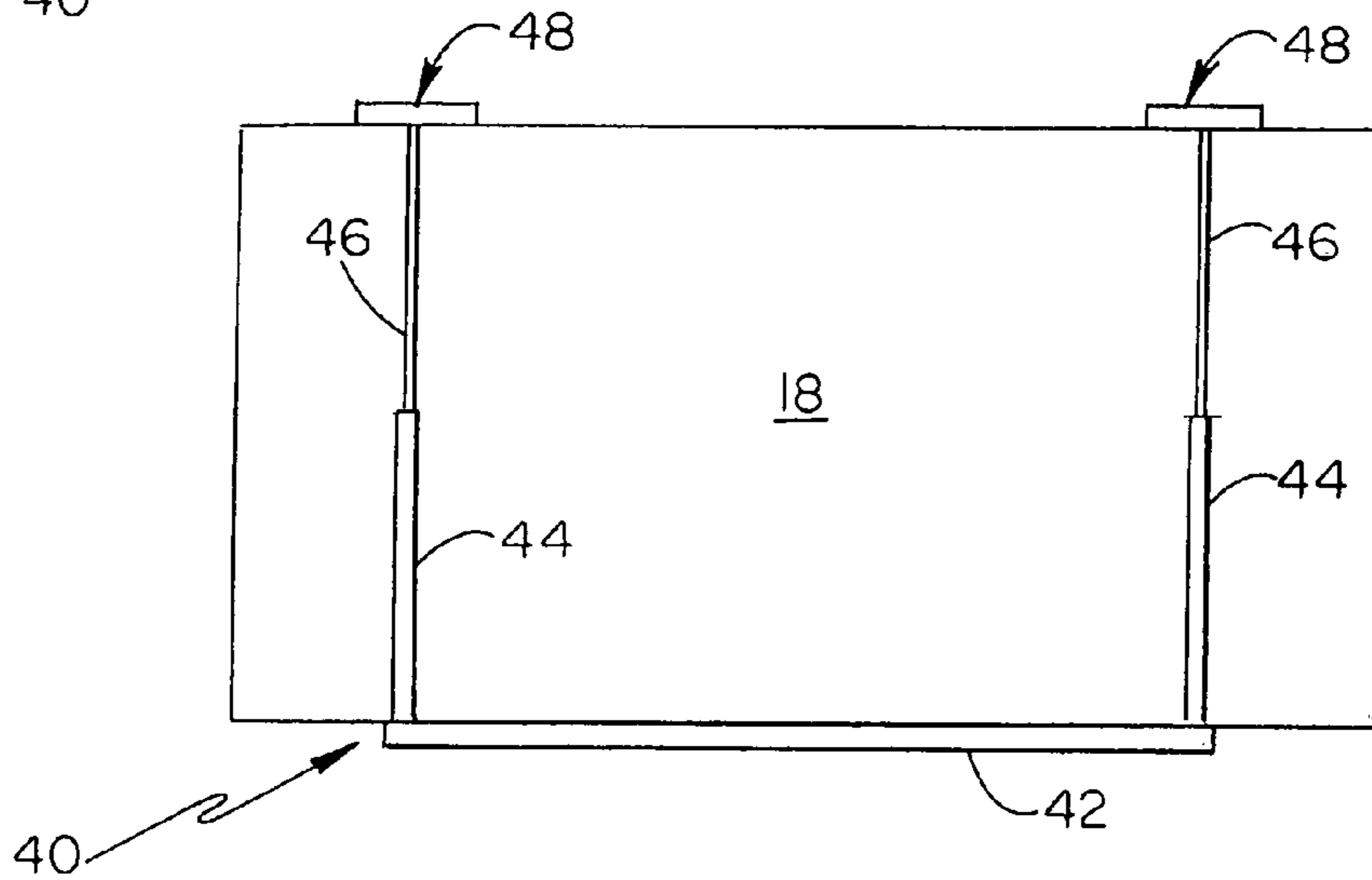

Fig.-3B

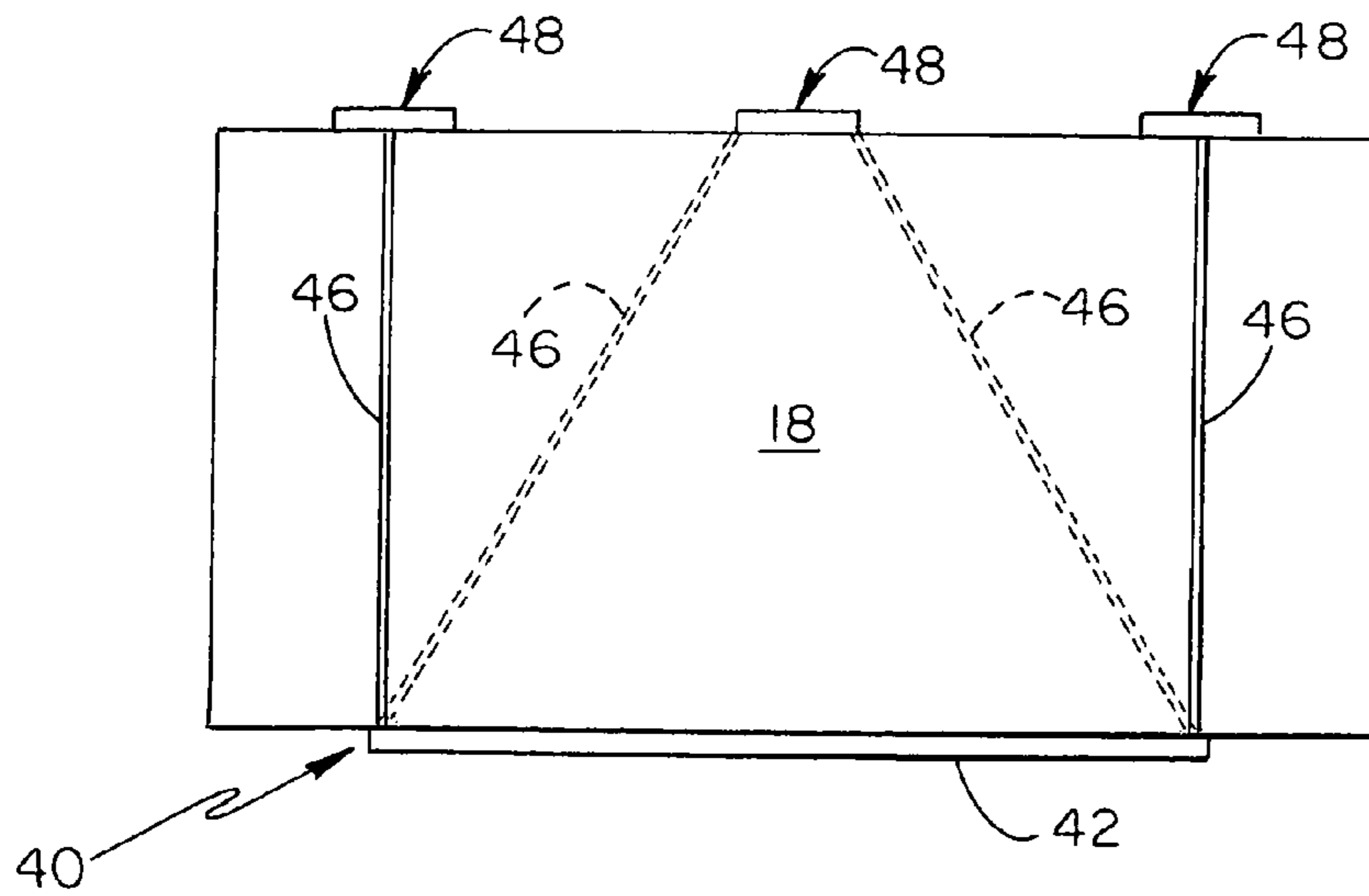
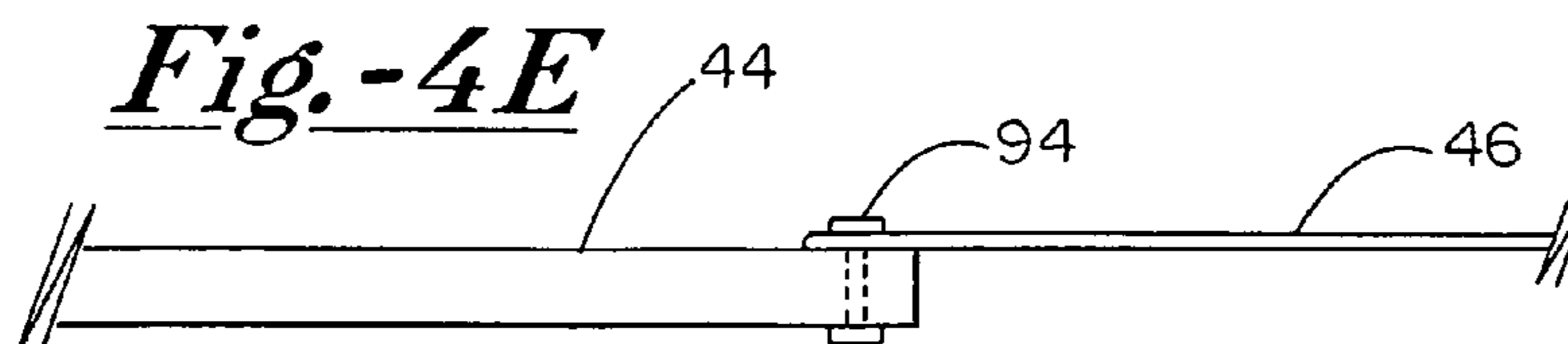
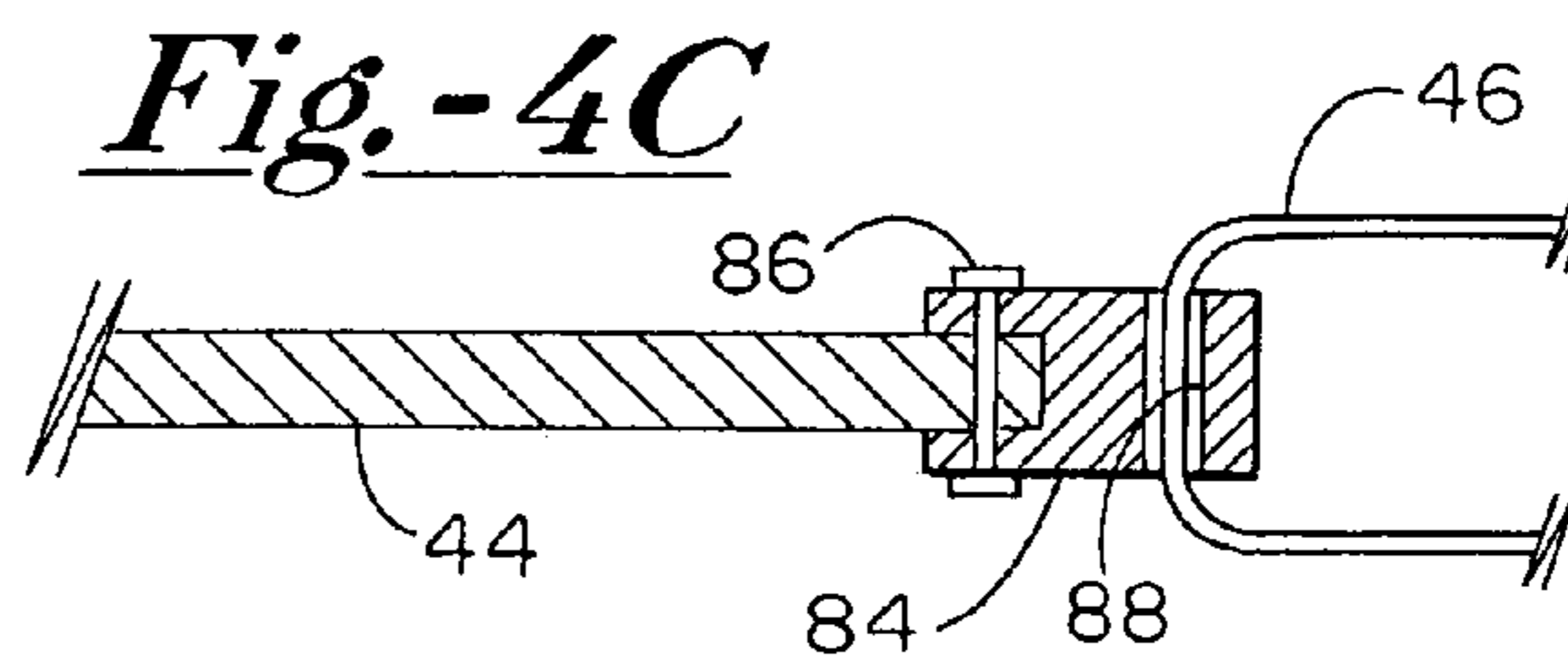
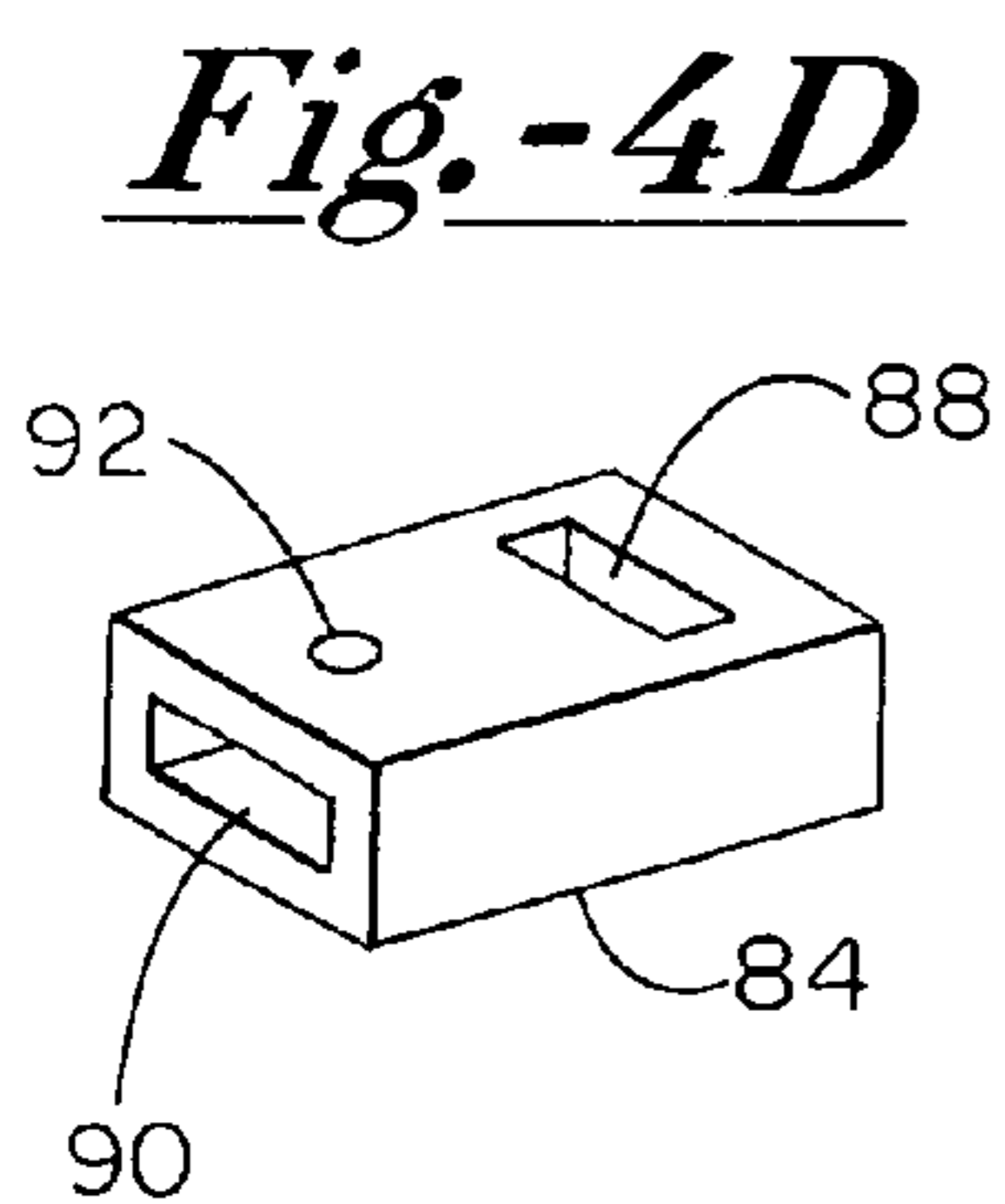
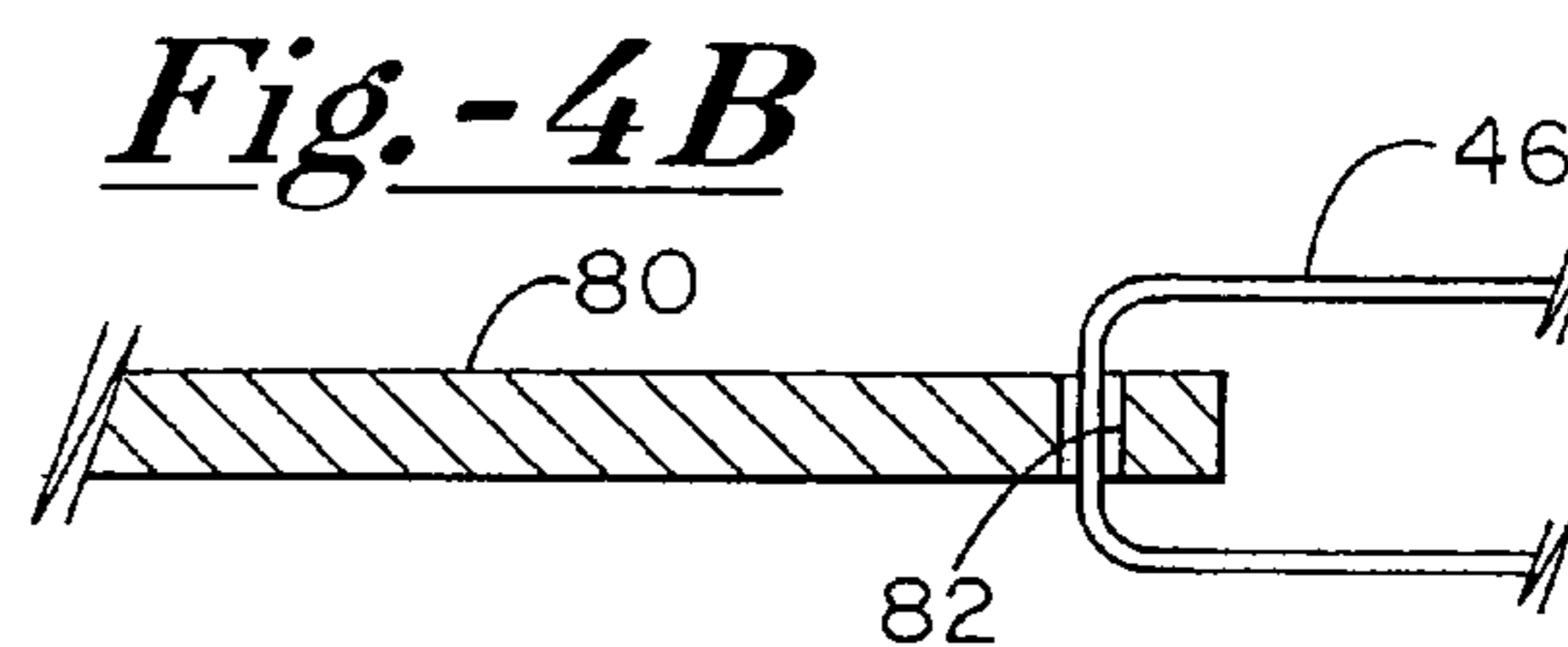
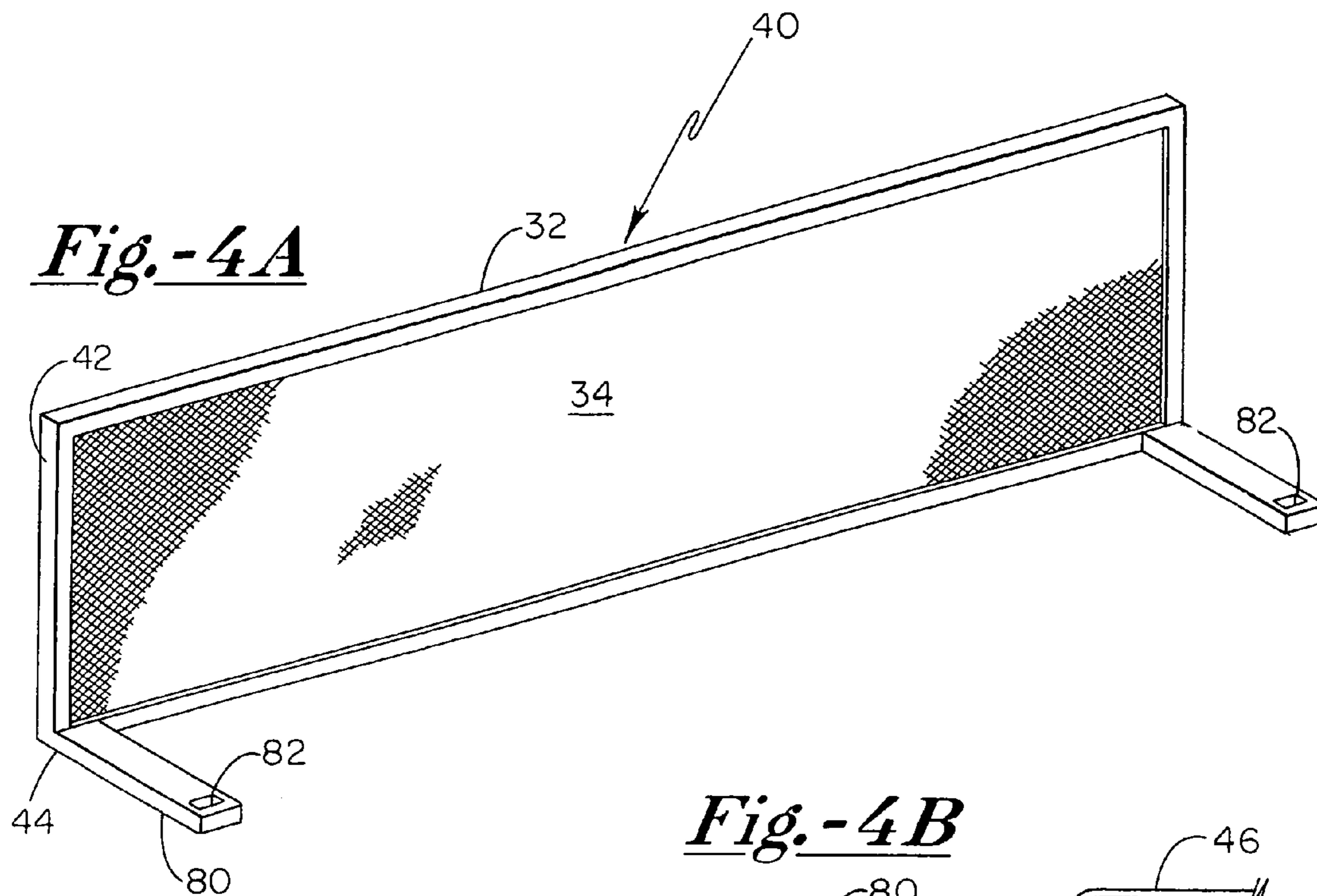
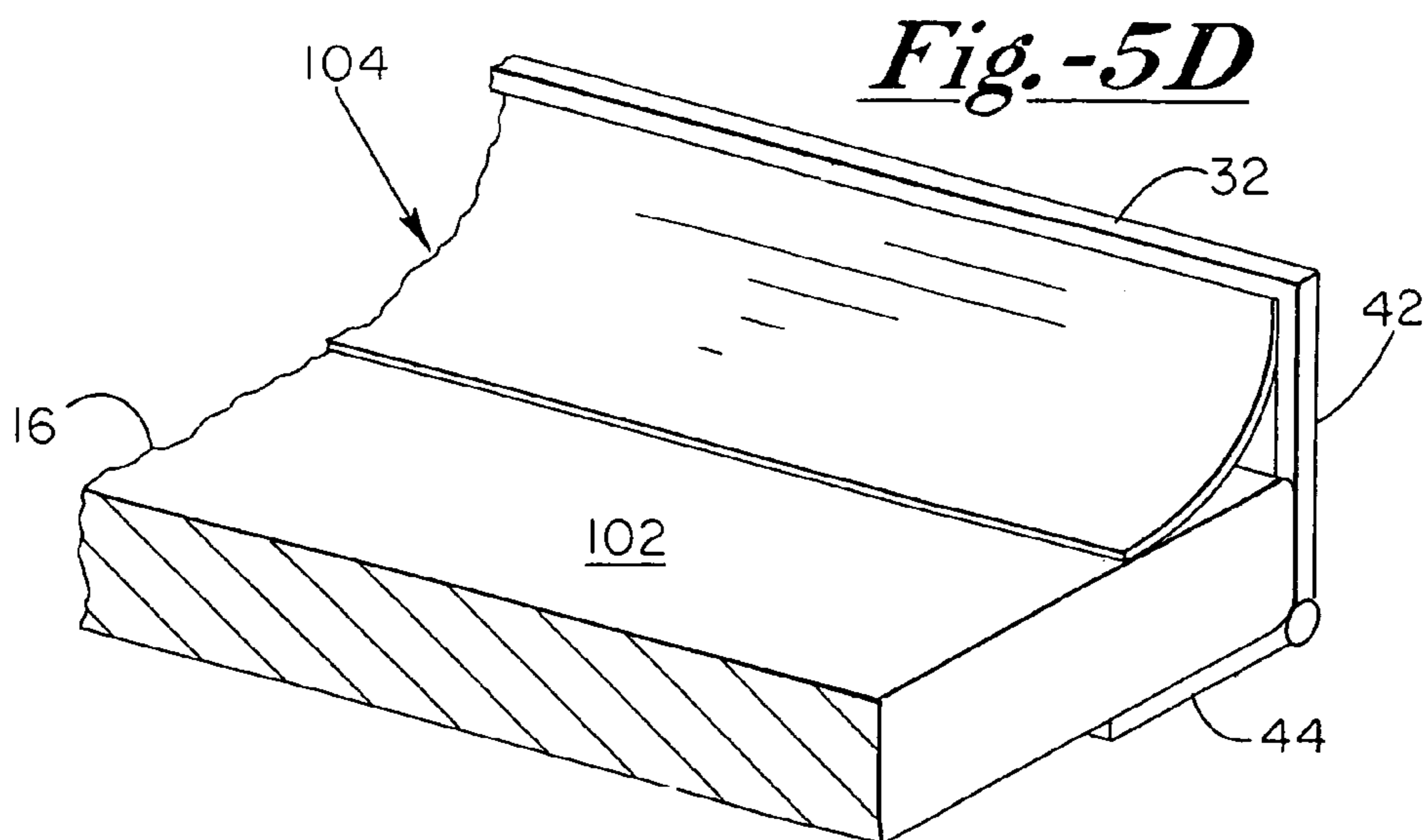
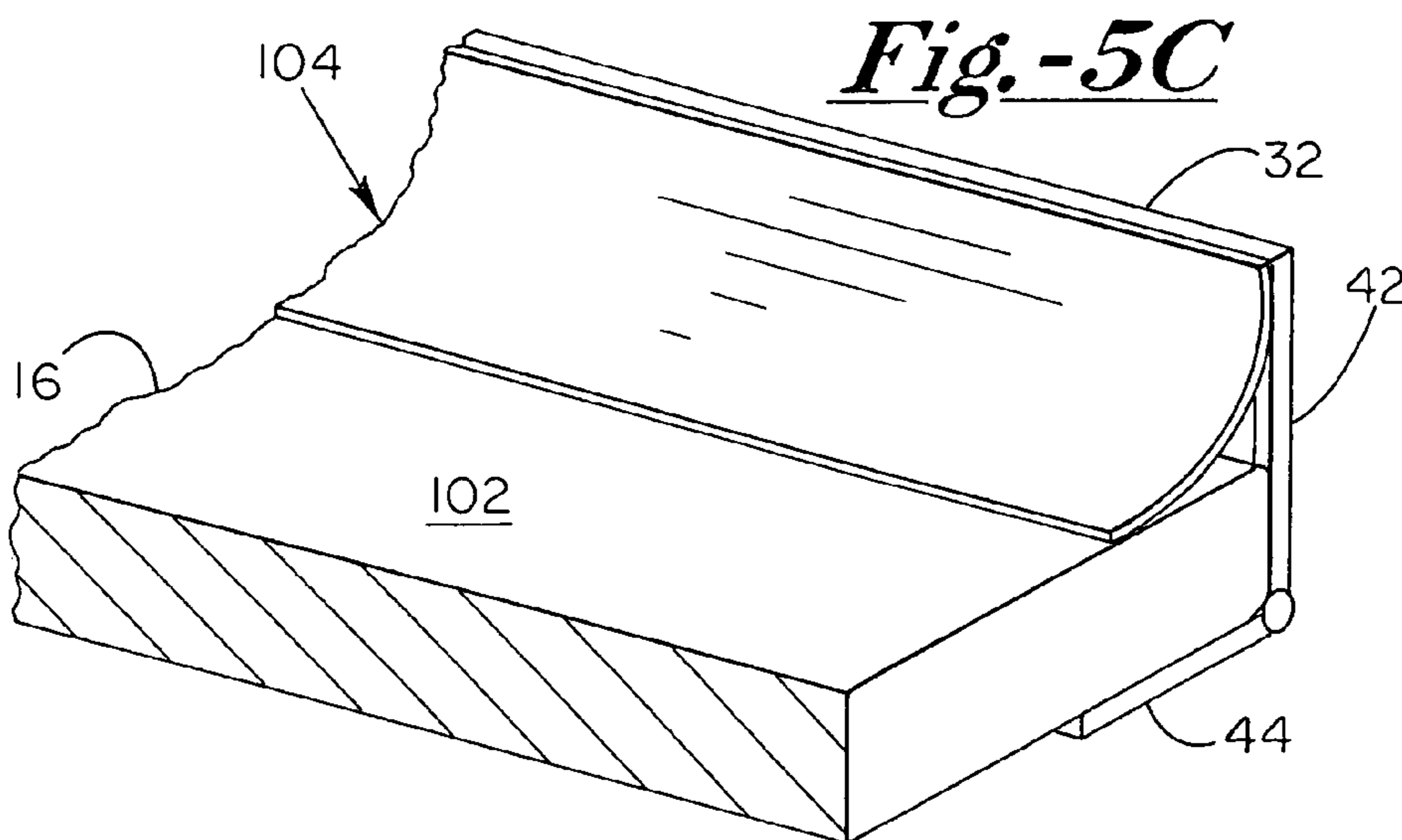
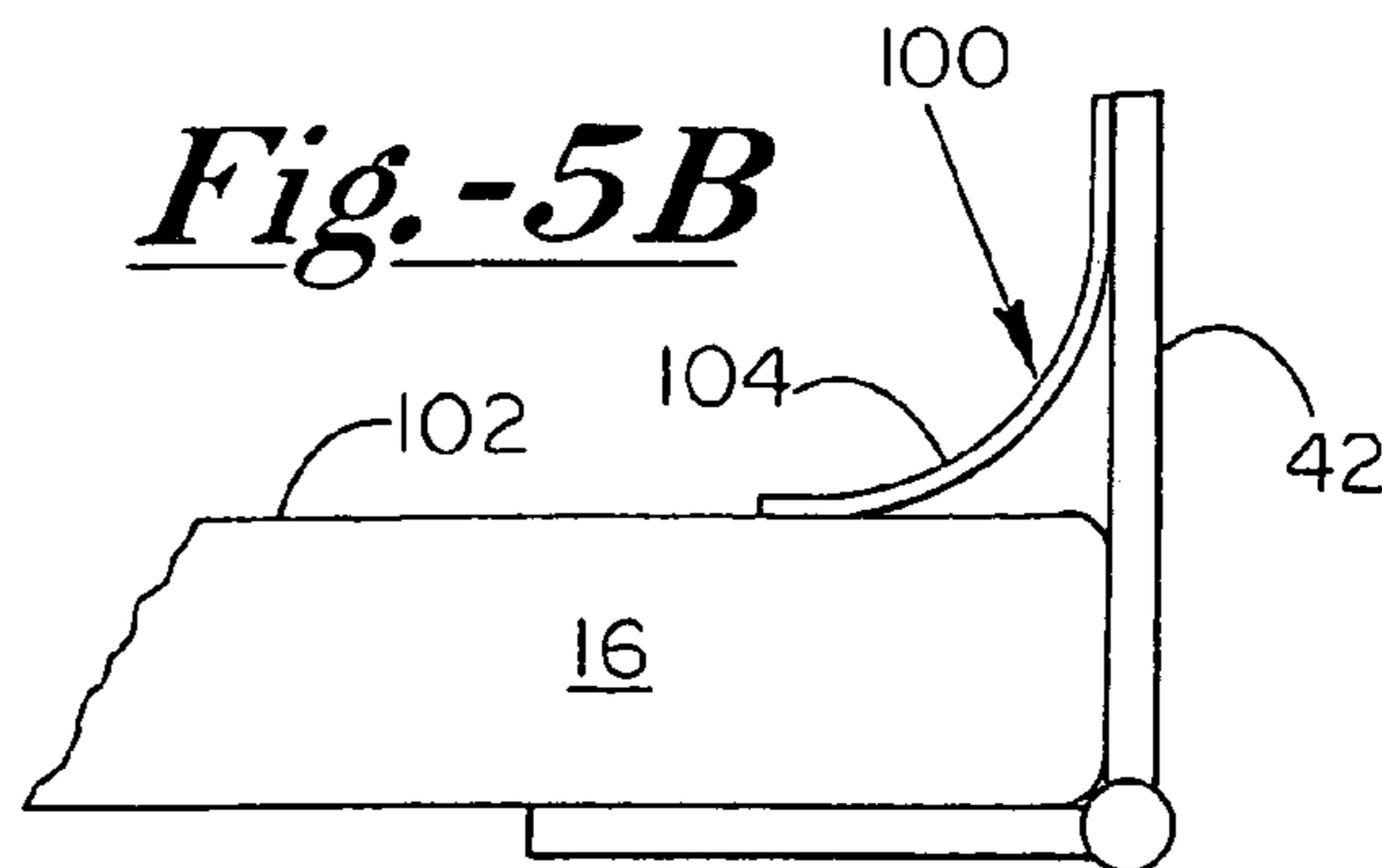
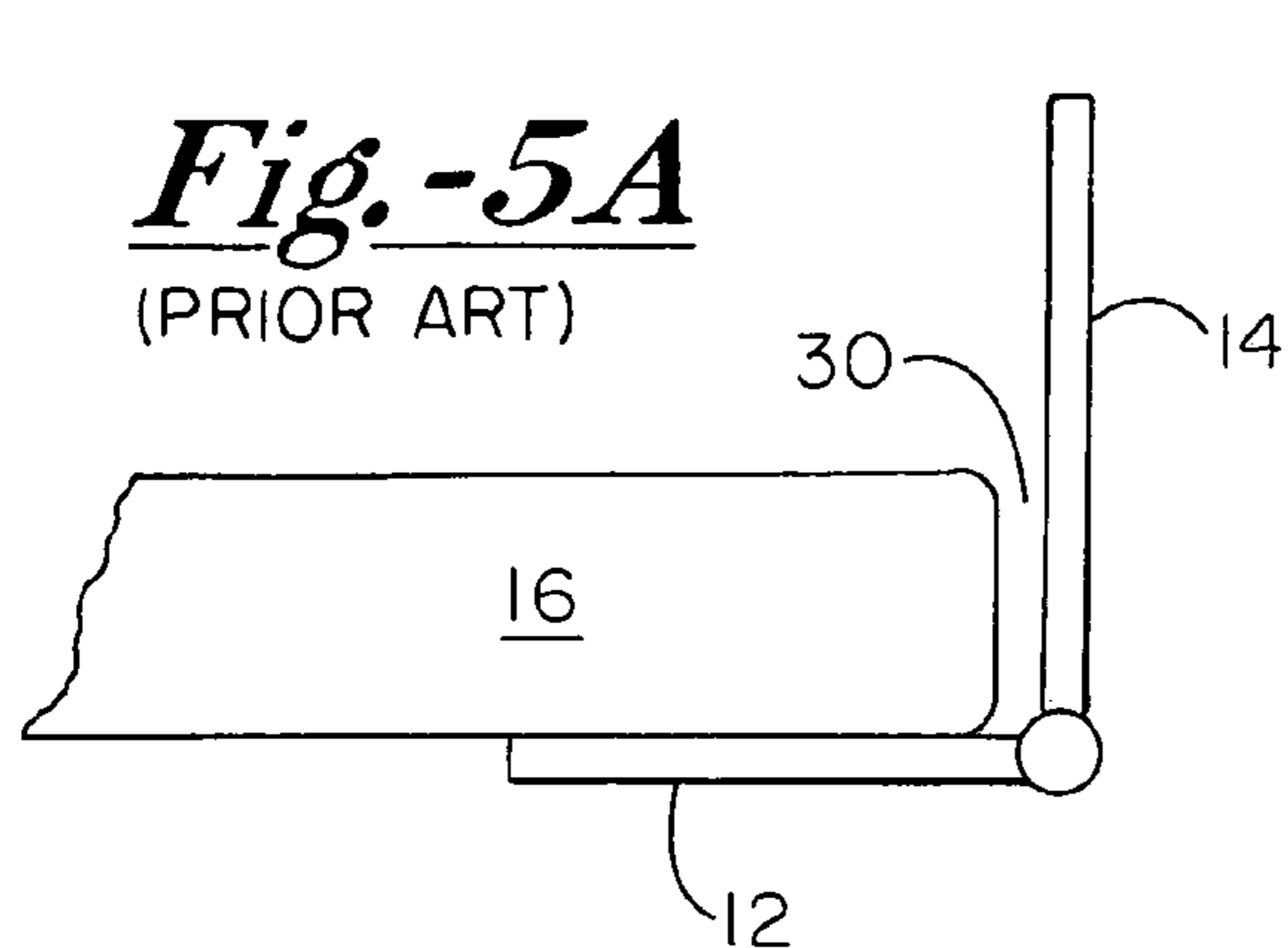
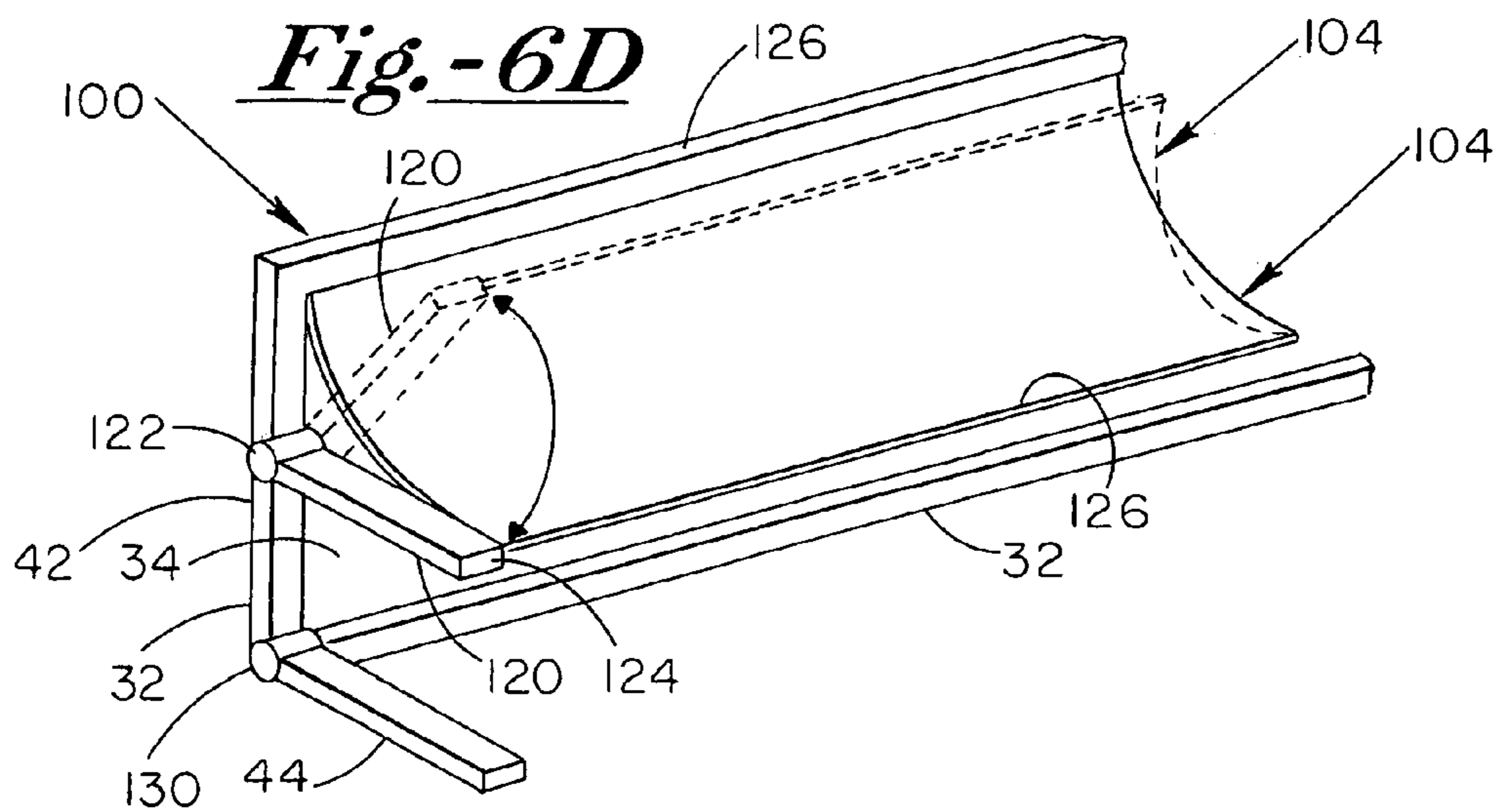
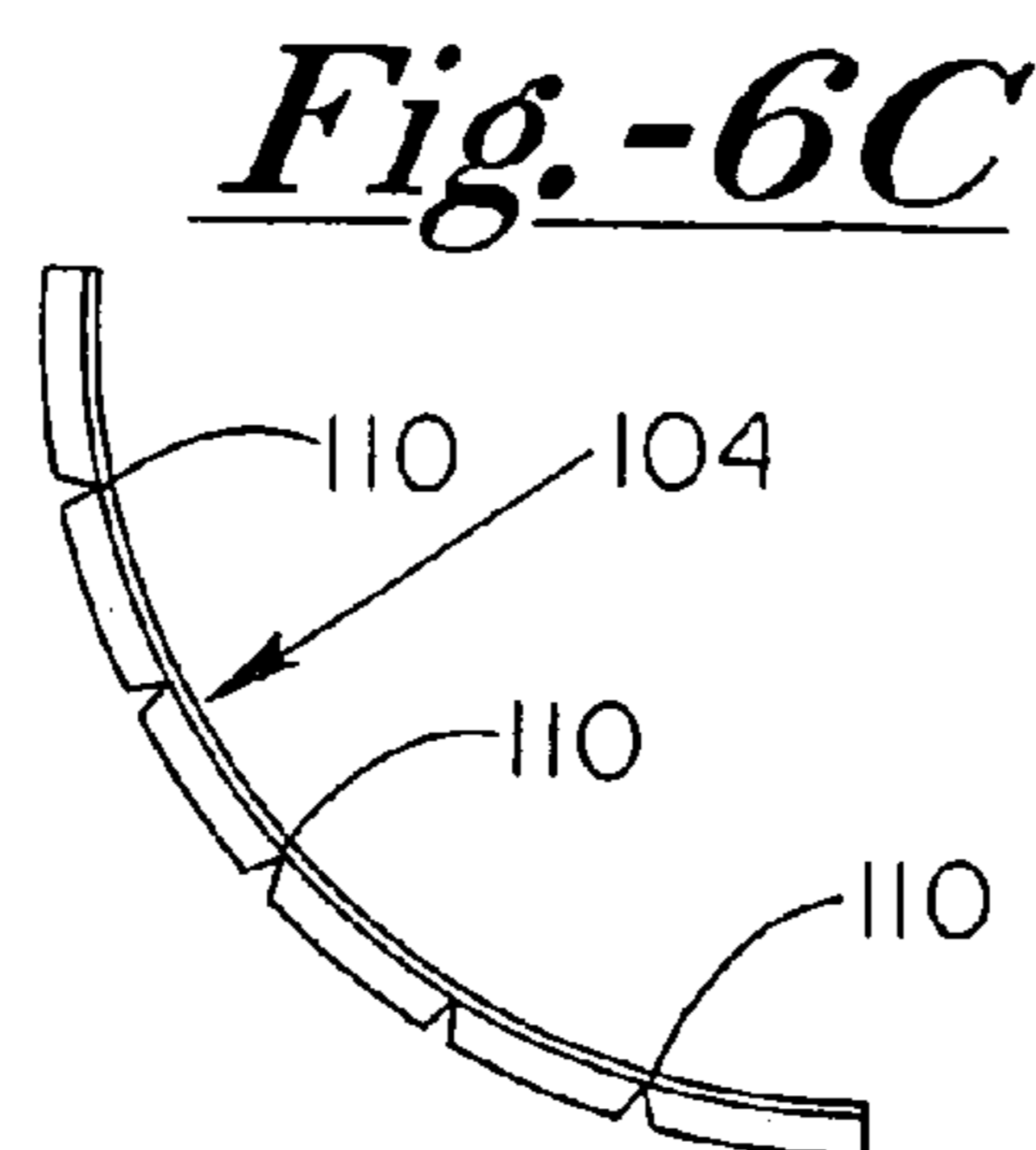
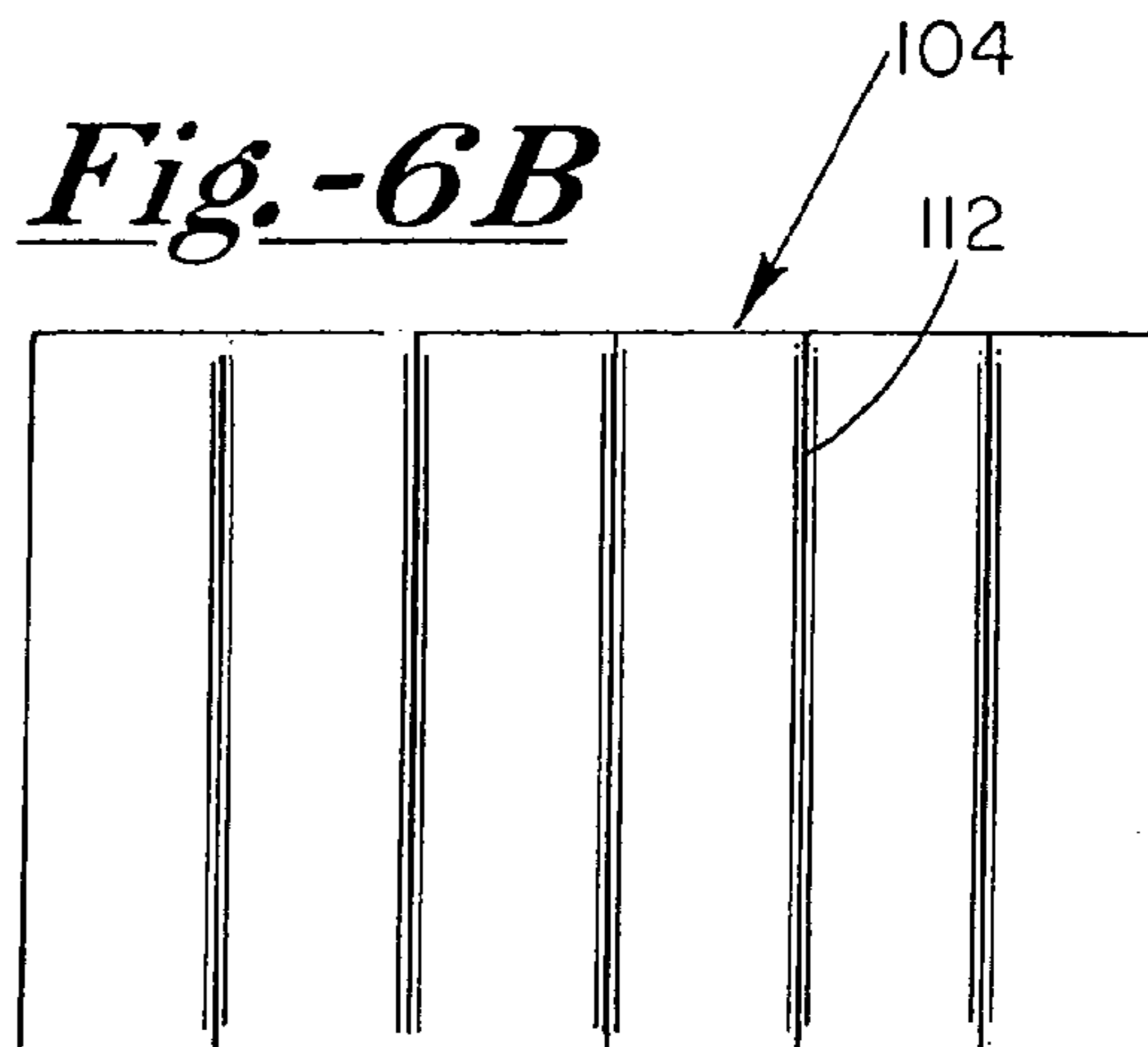
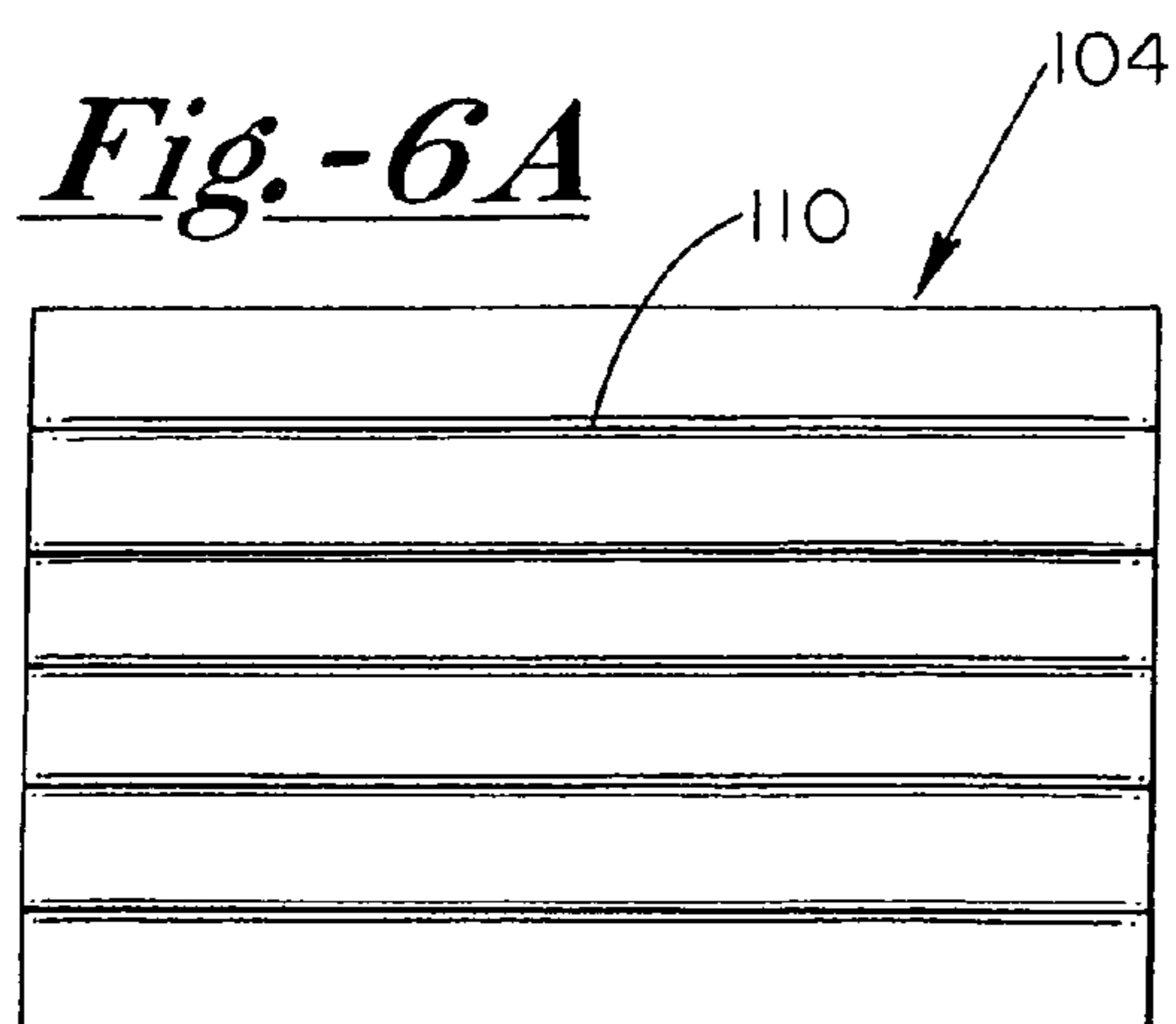

Fig.-3C







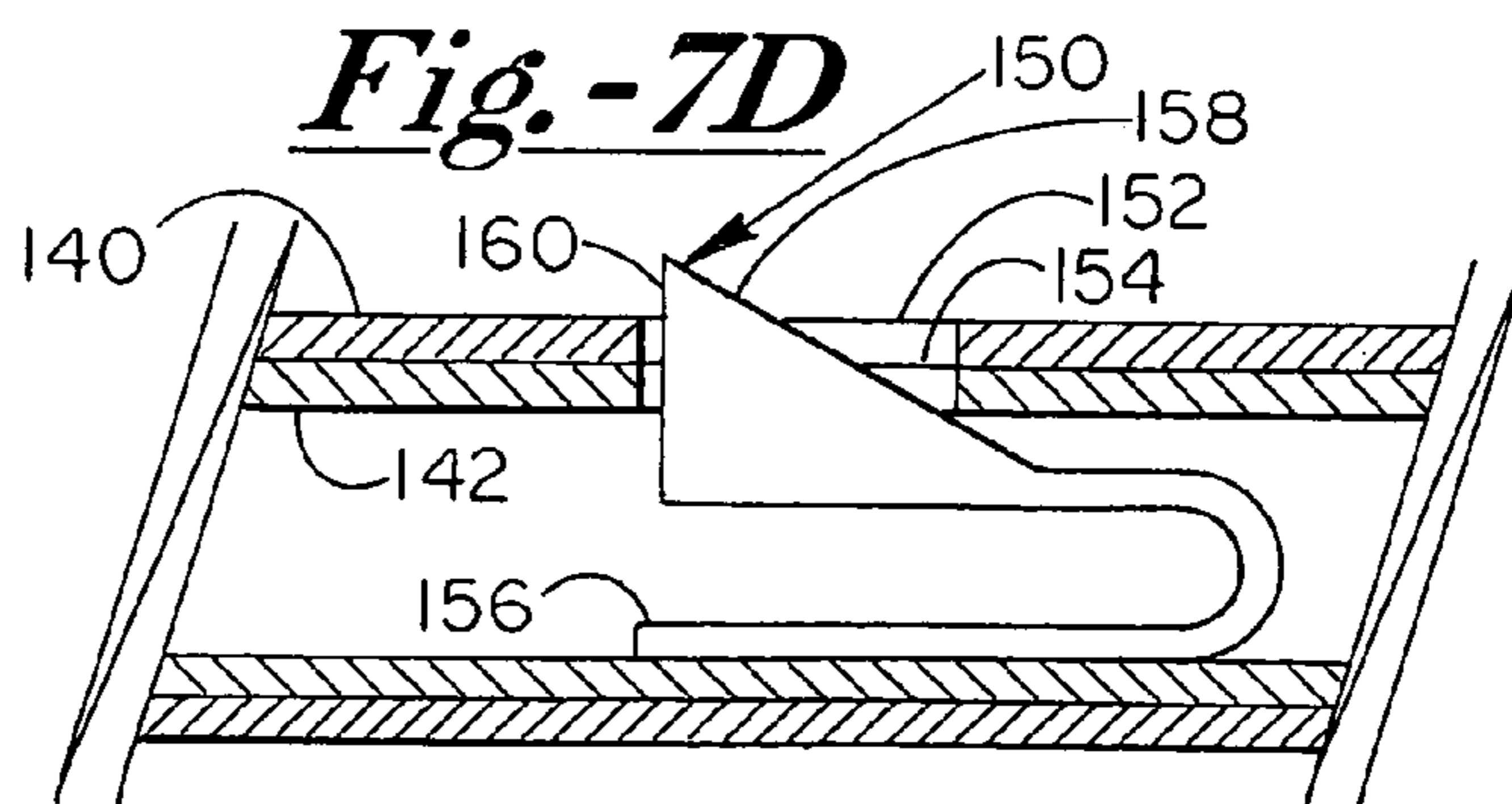
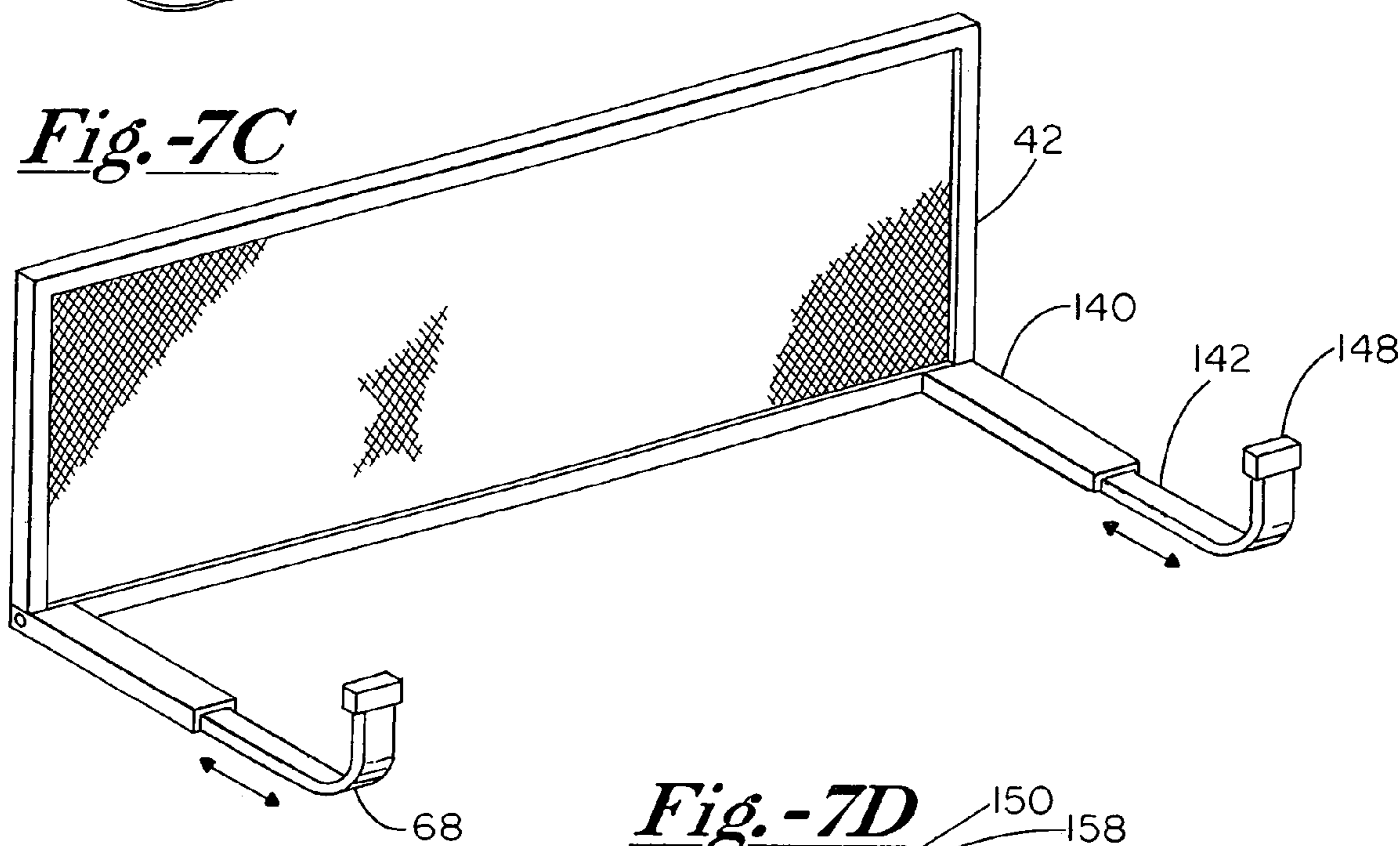
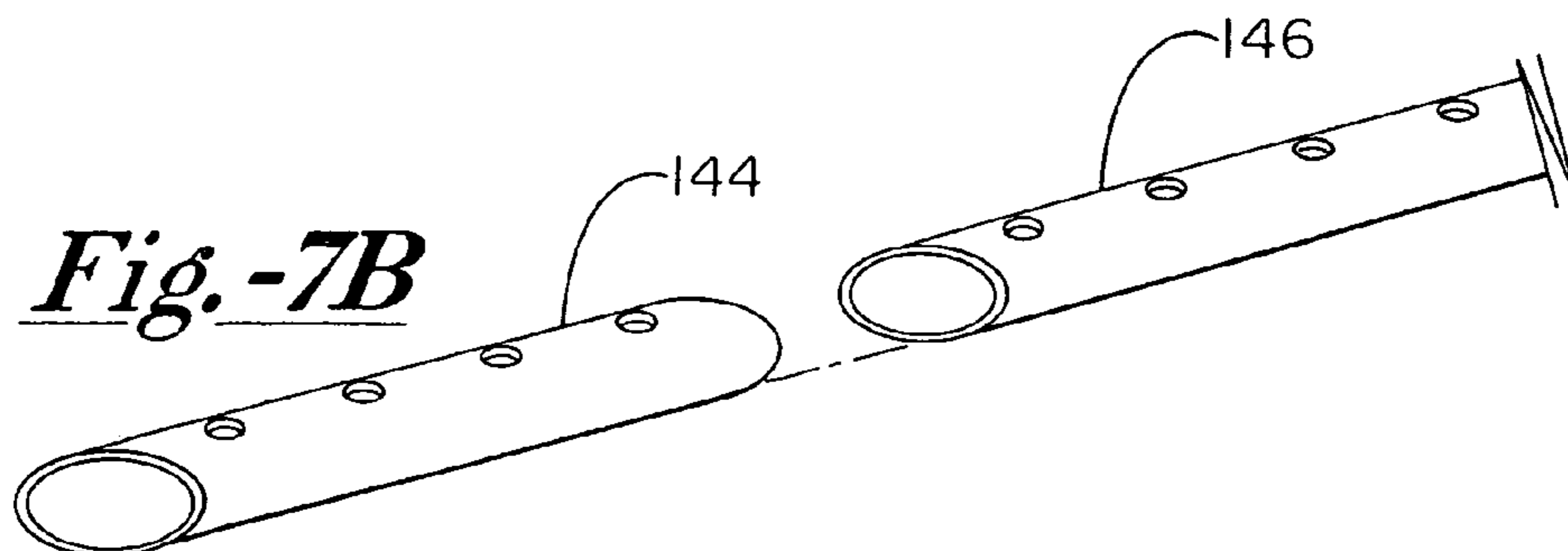
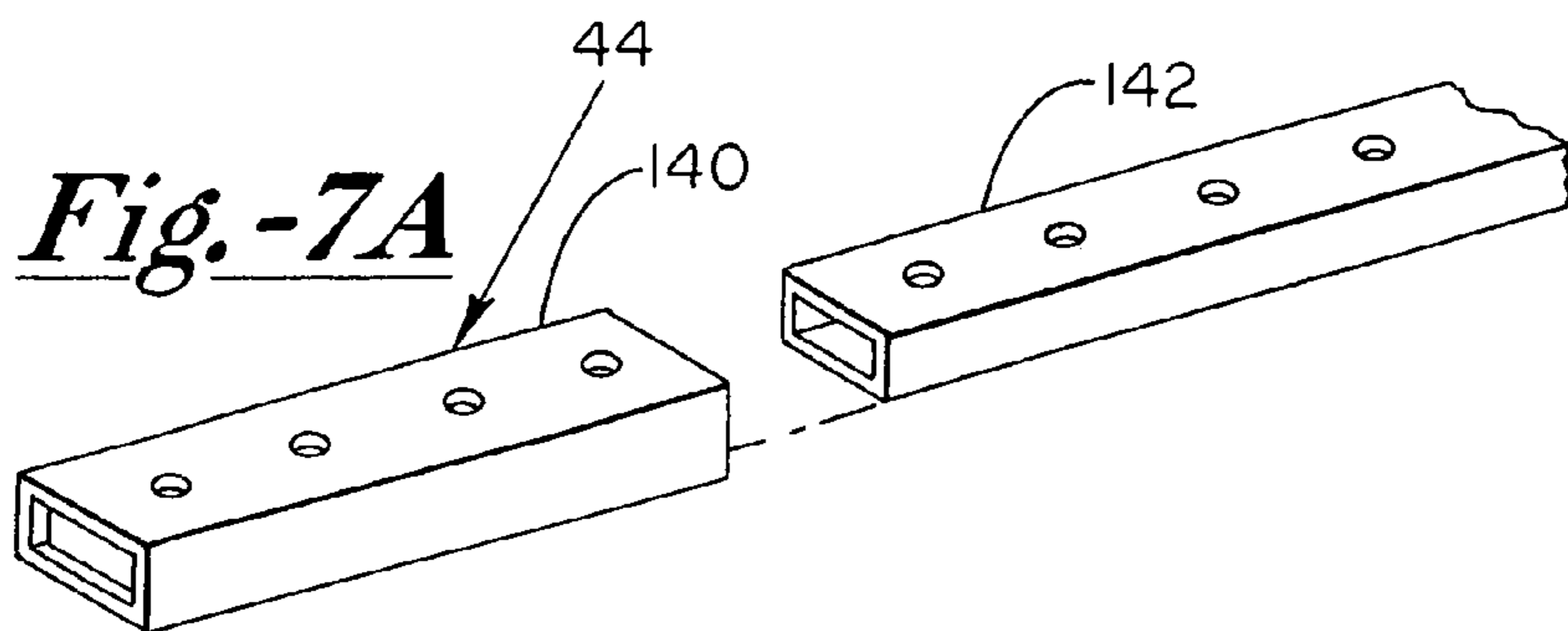
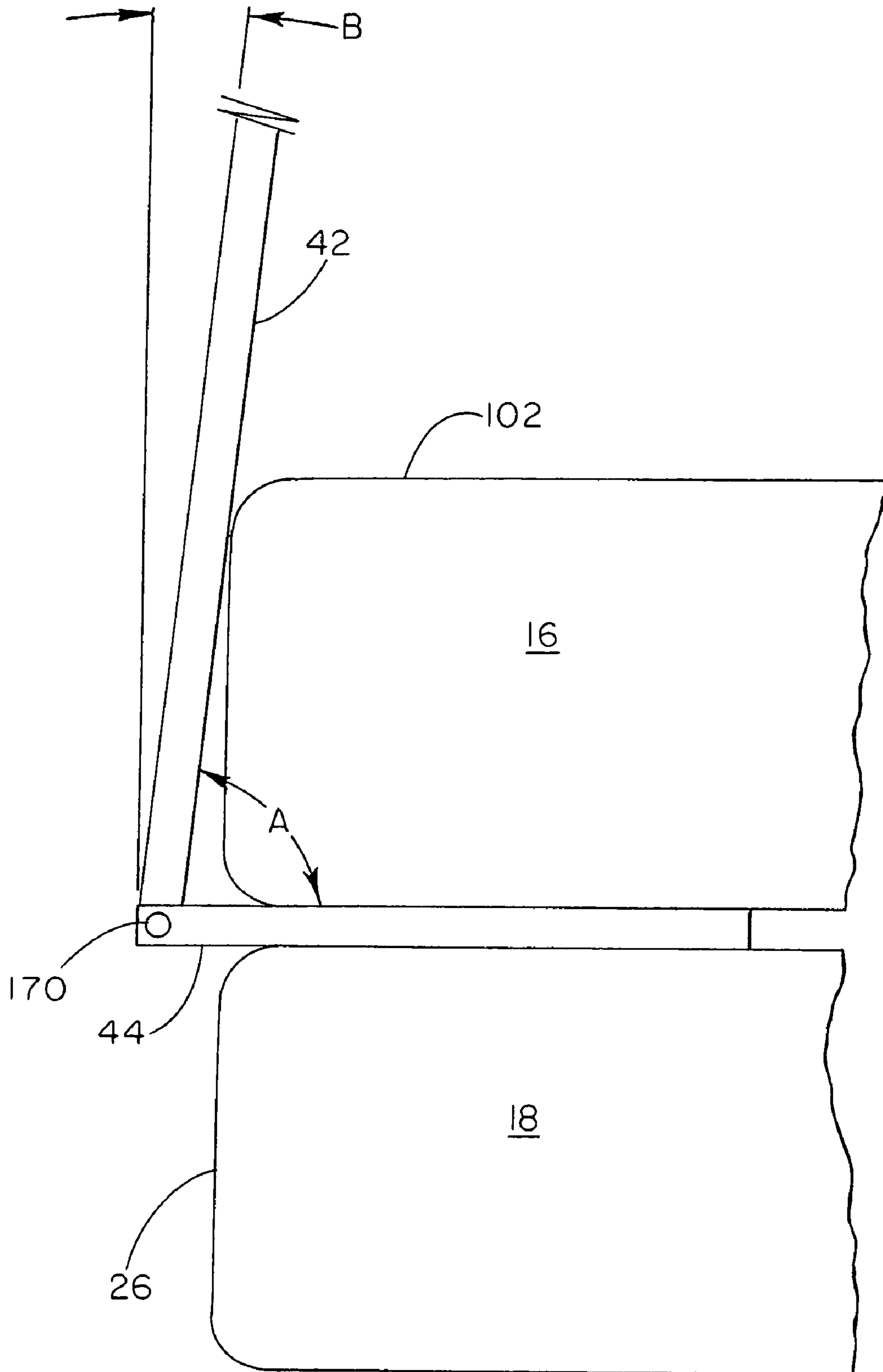

Fig.-8



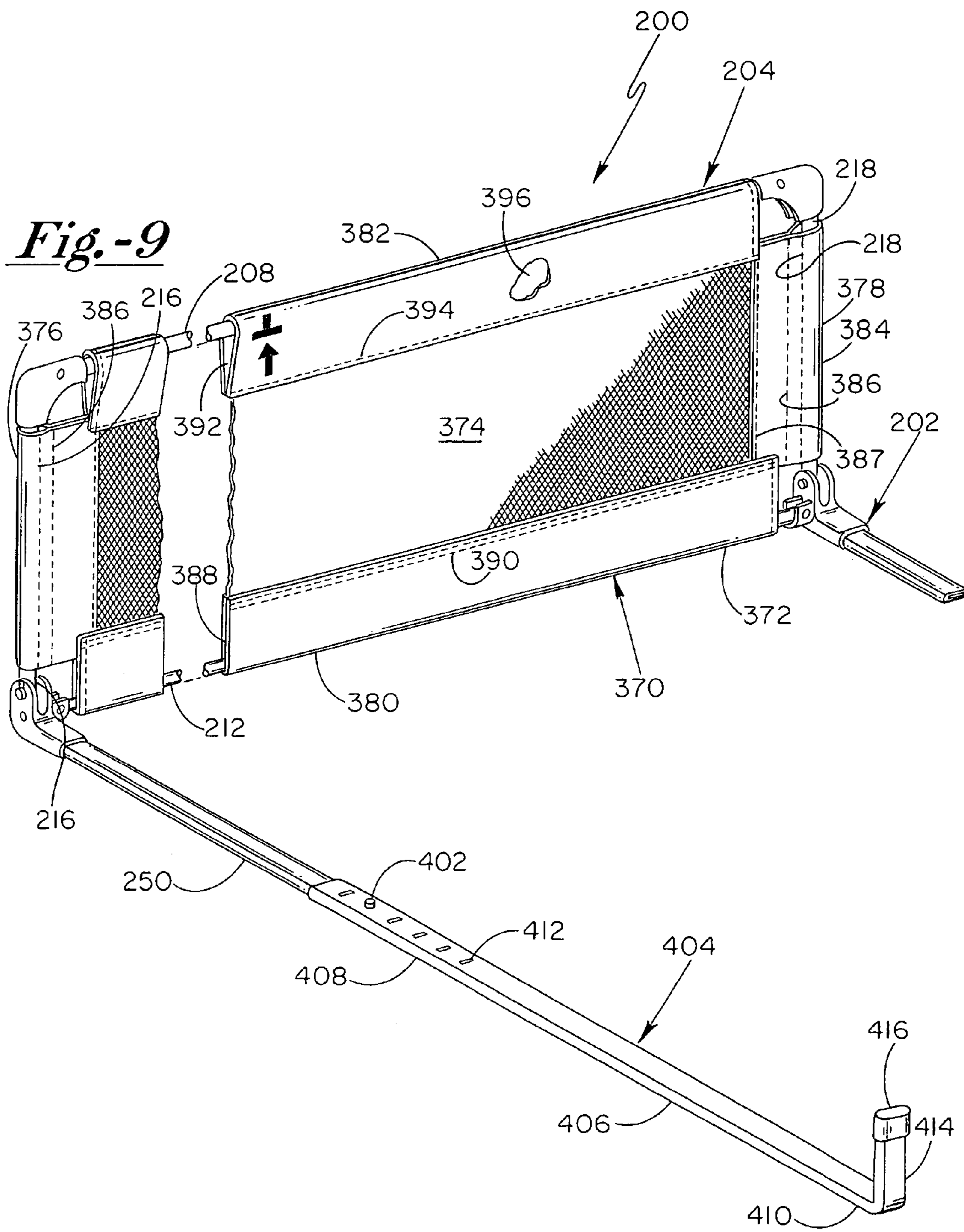
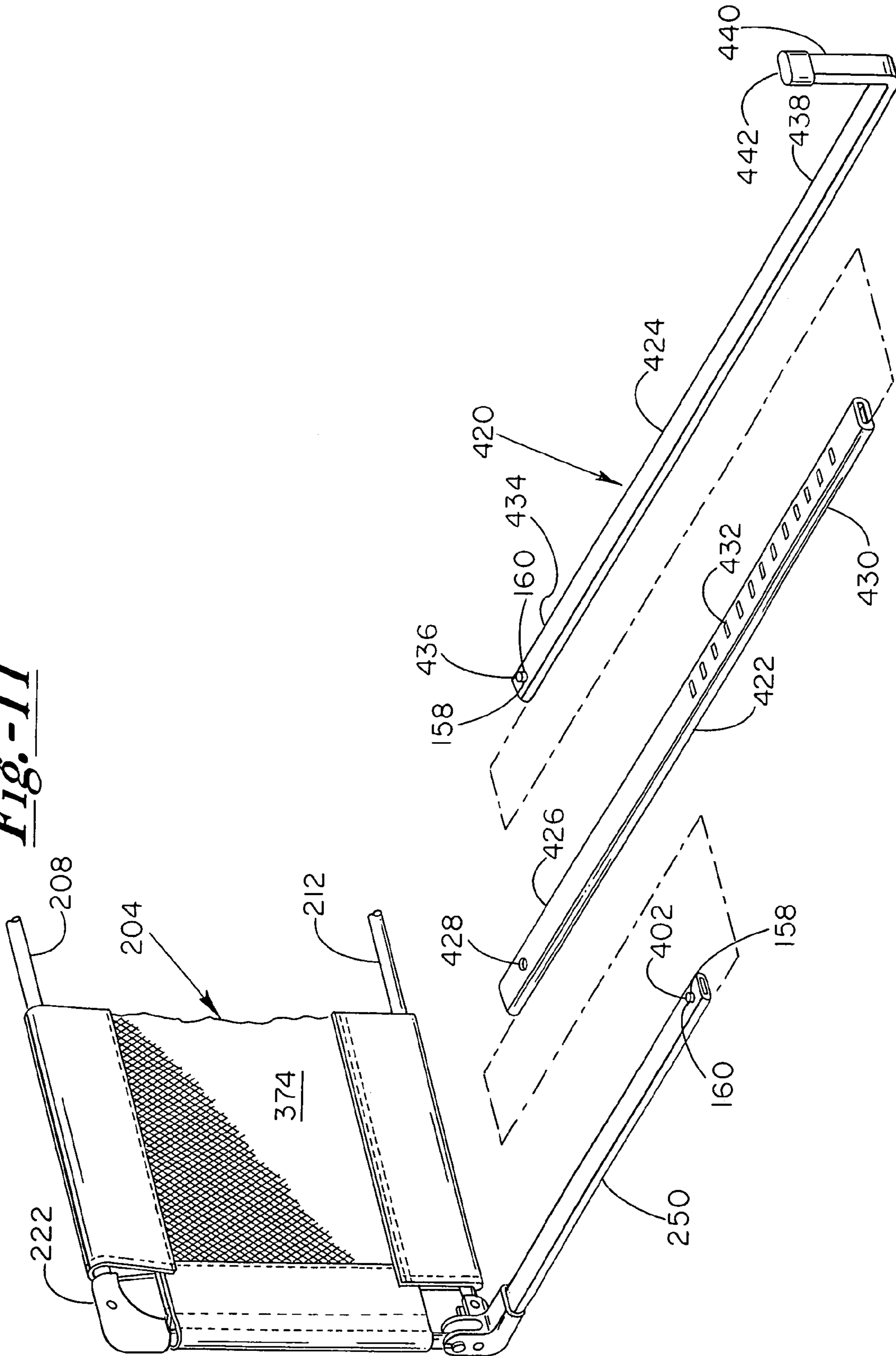

Fig.-11



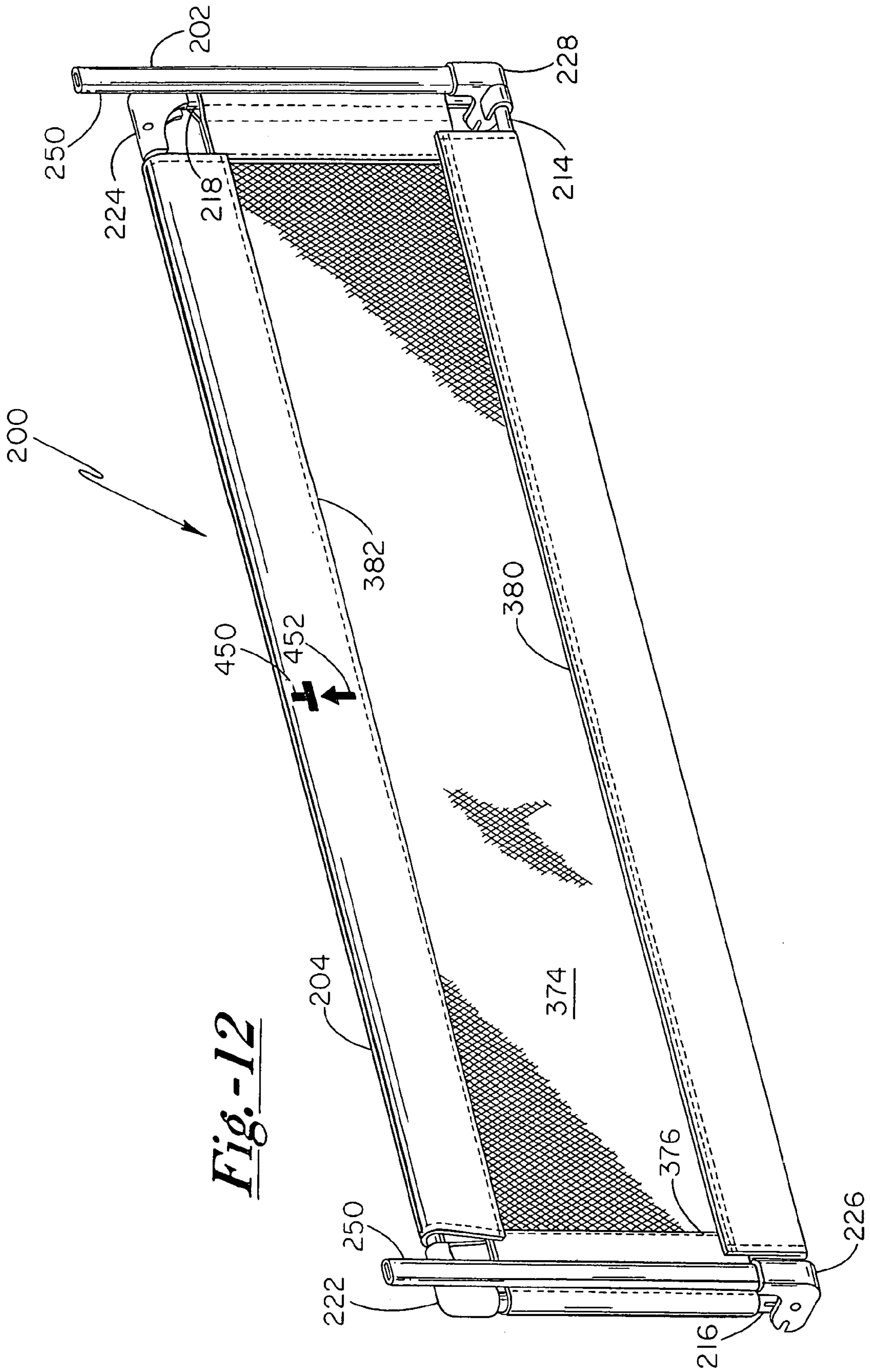
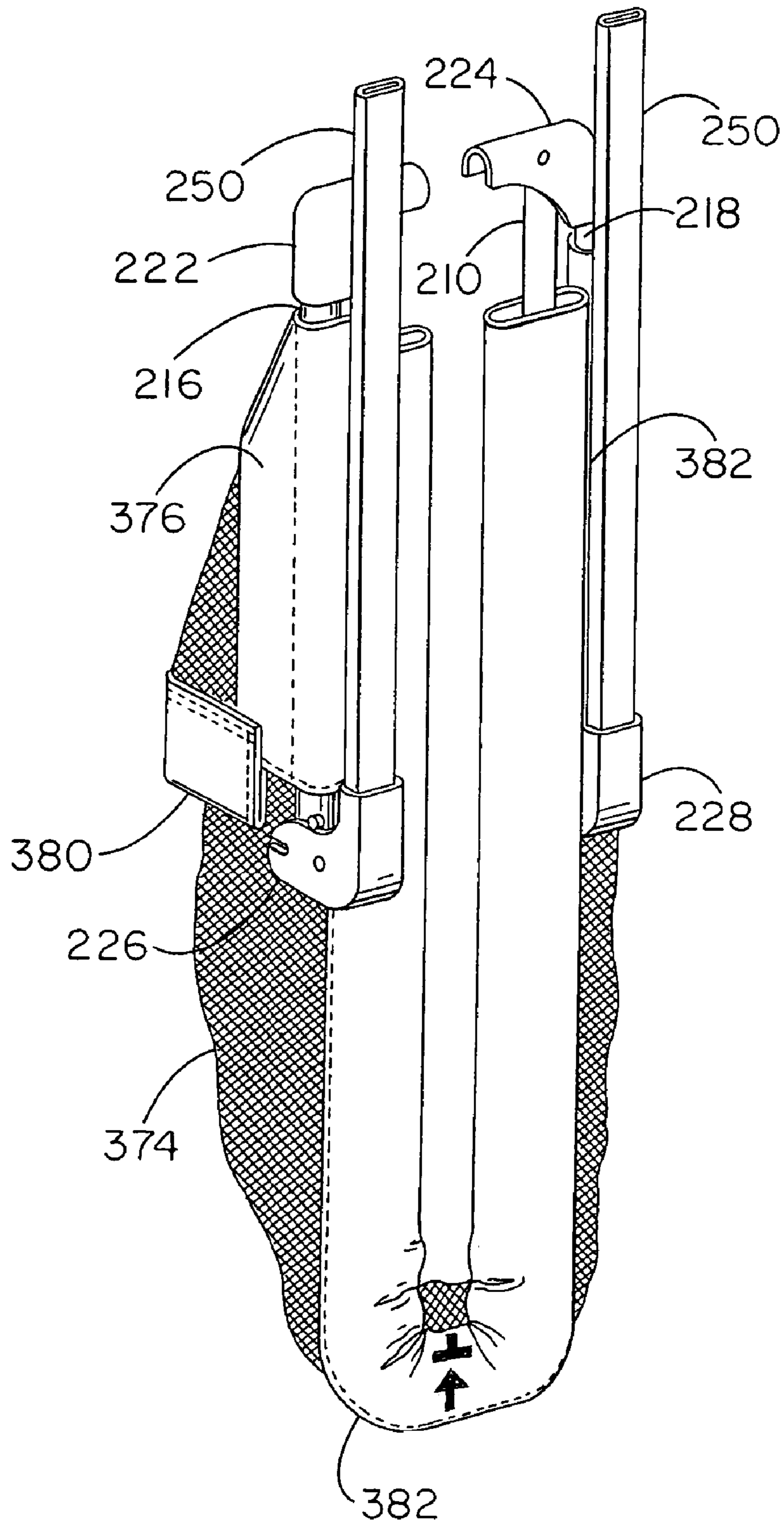
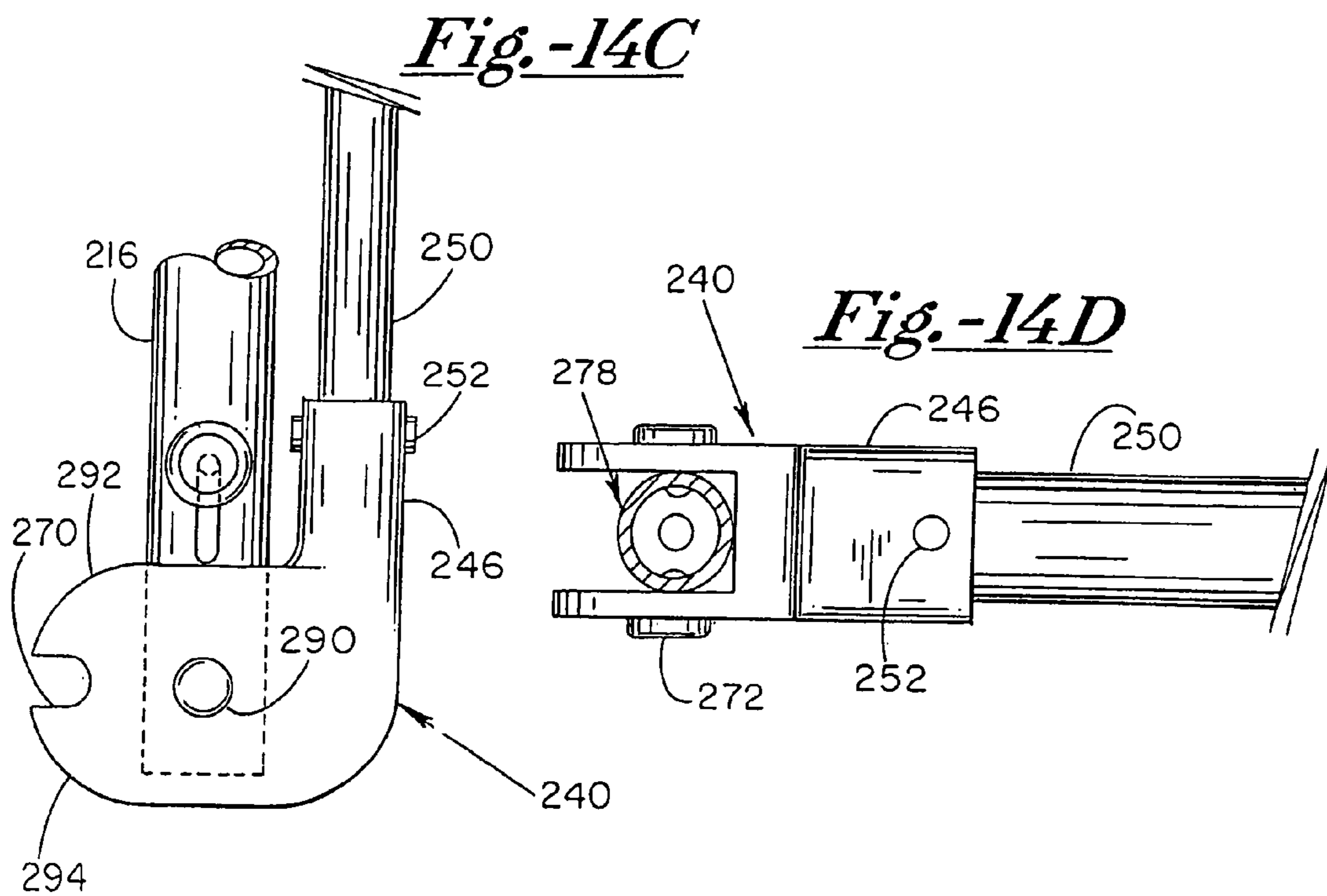
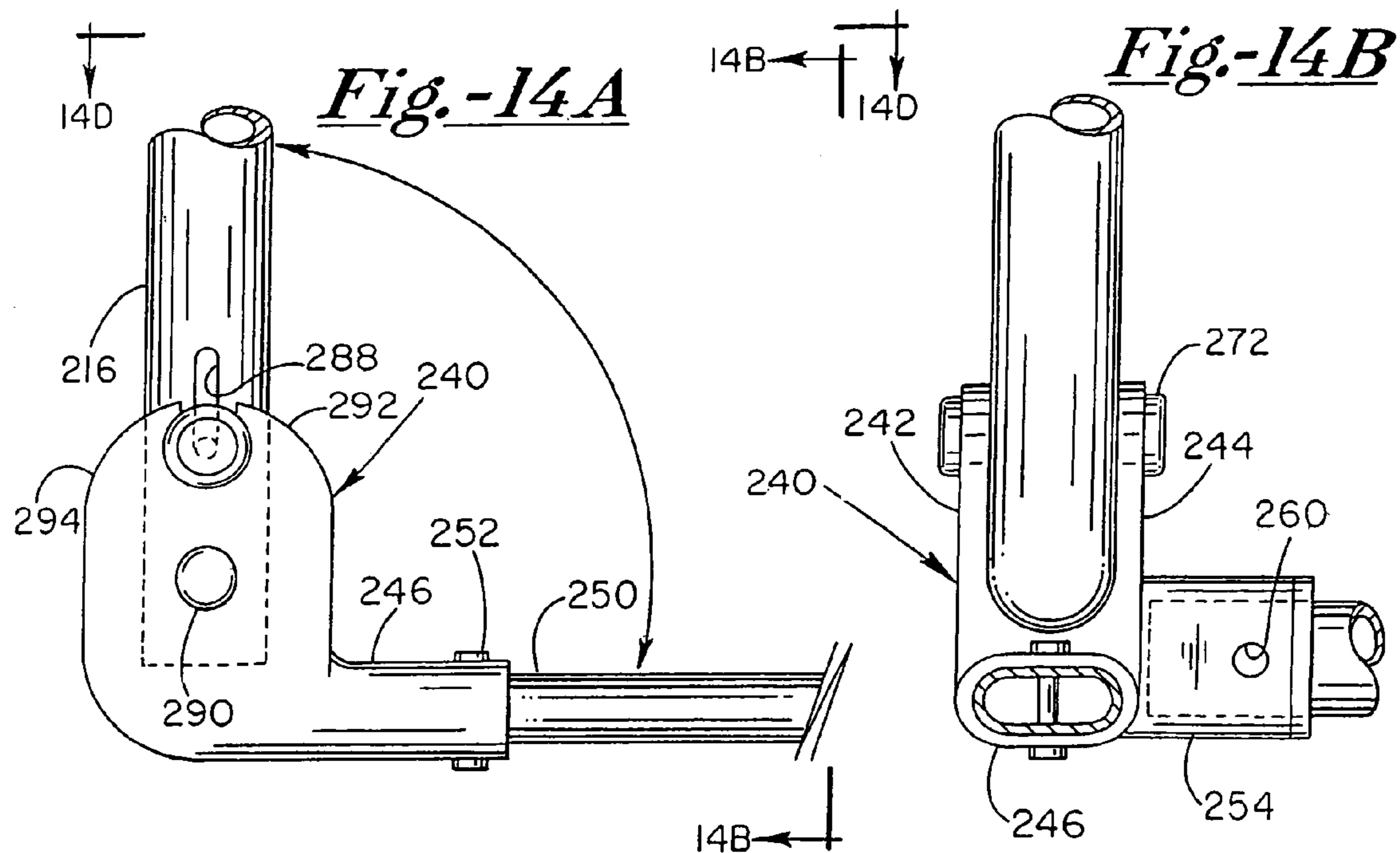

Fig.-12

Fig.-13





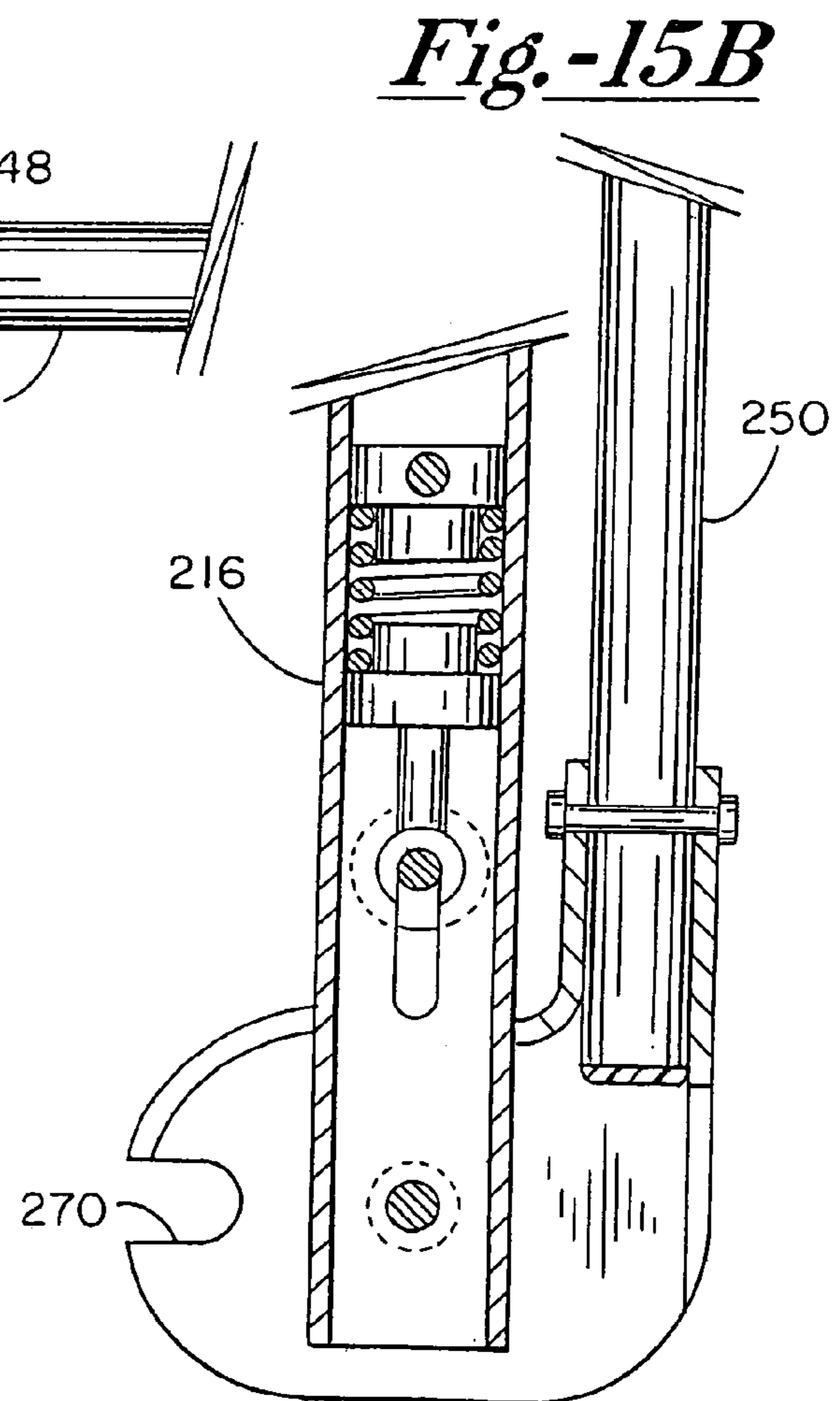
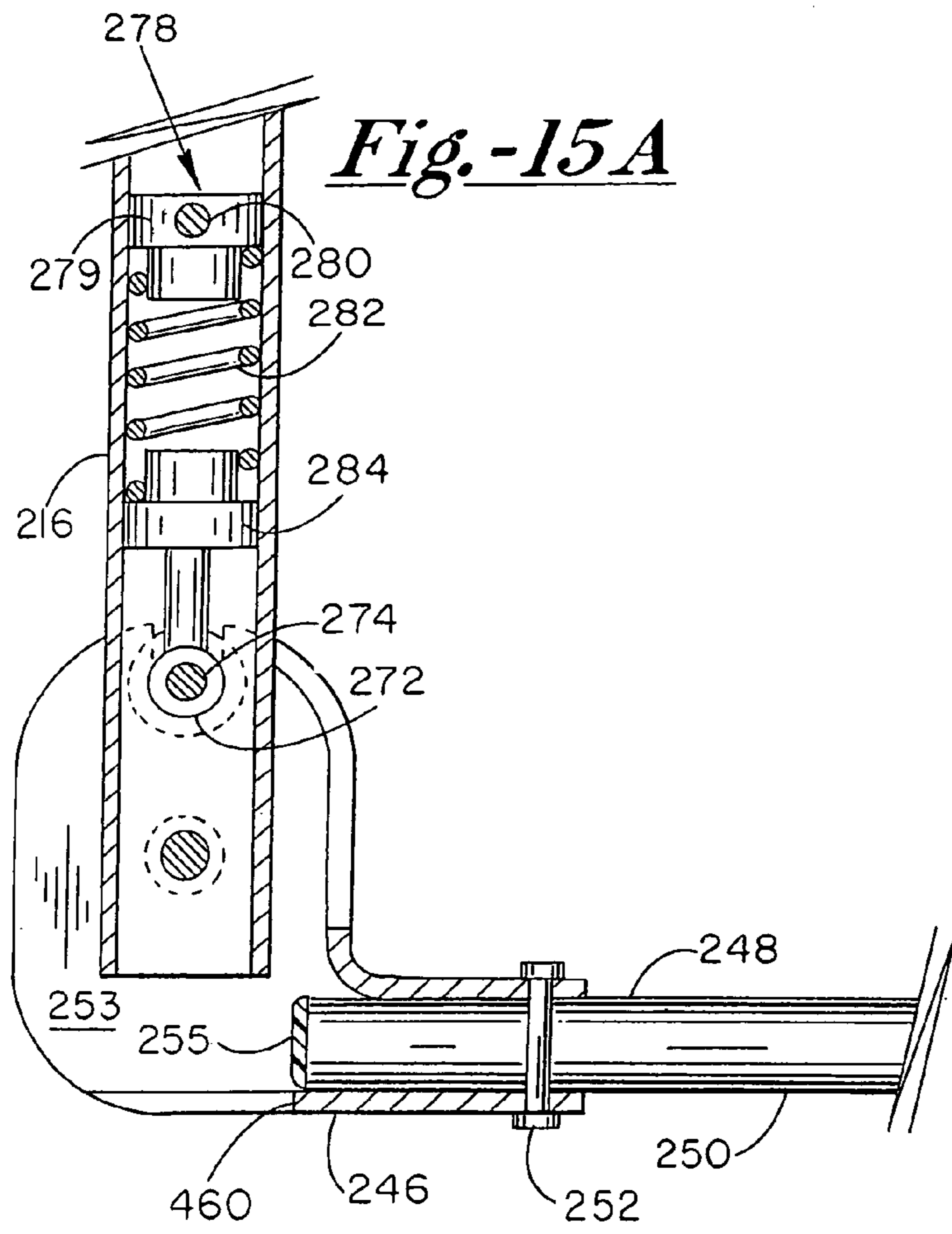

Fig.-16A

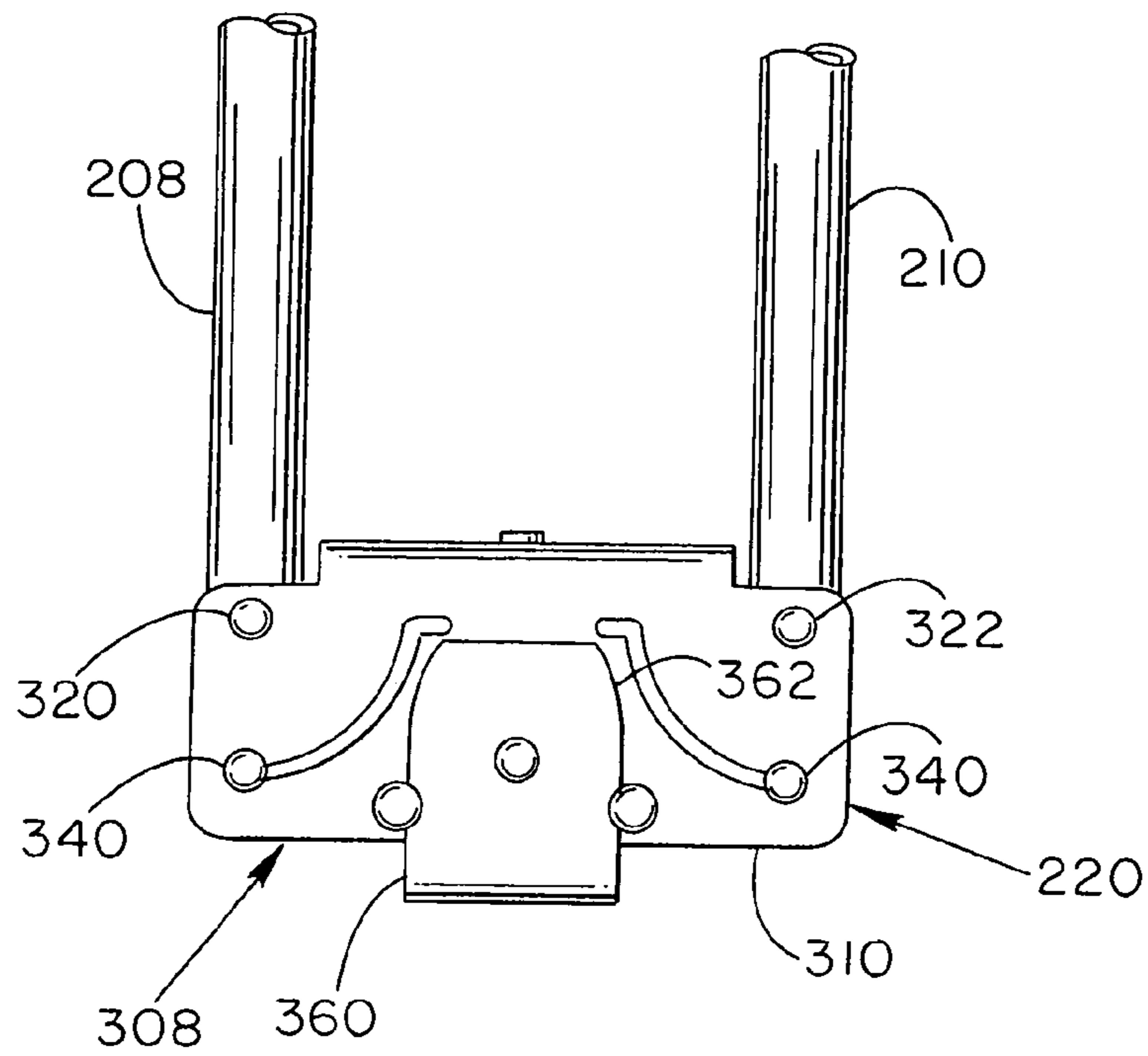
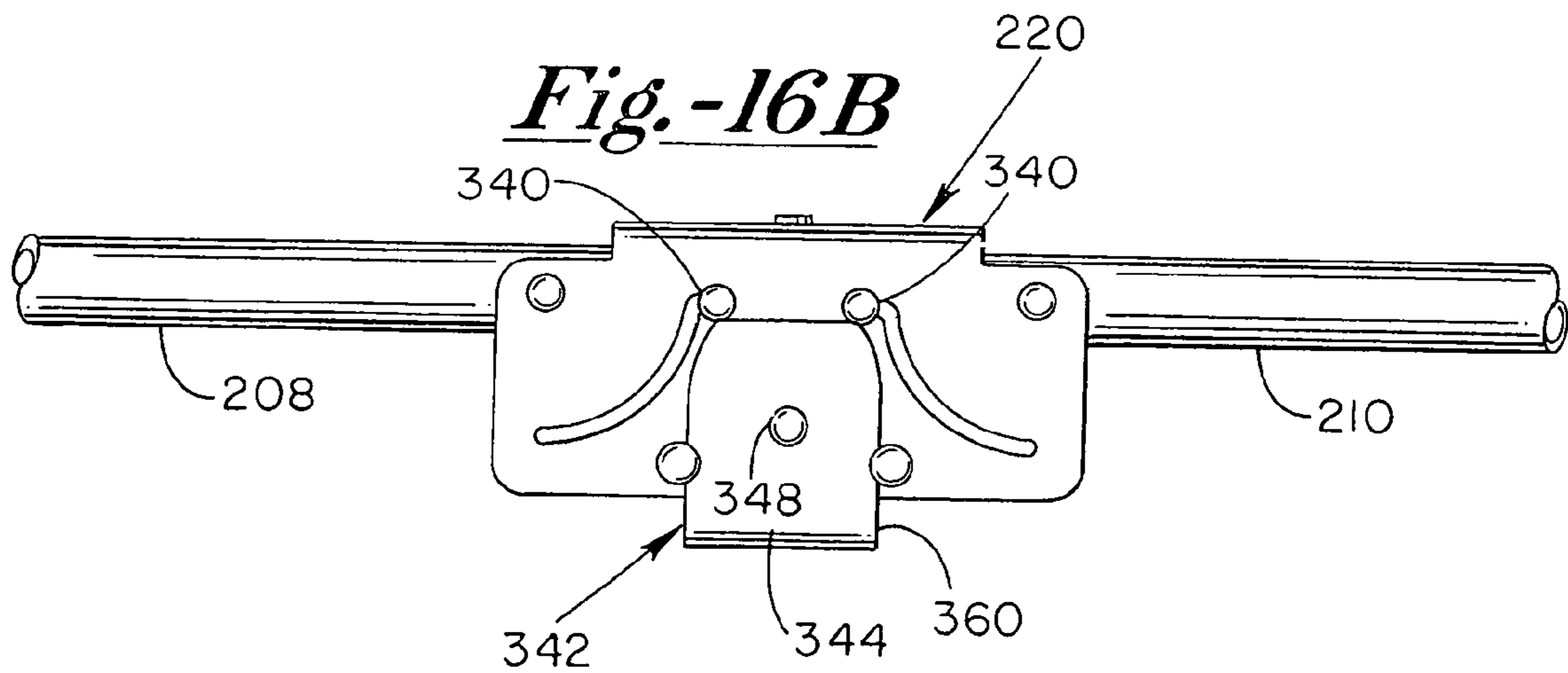

Fig.-16B



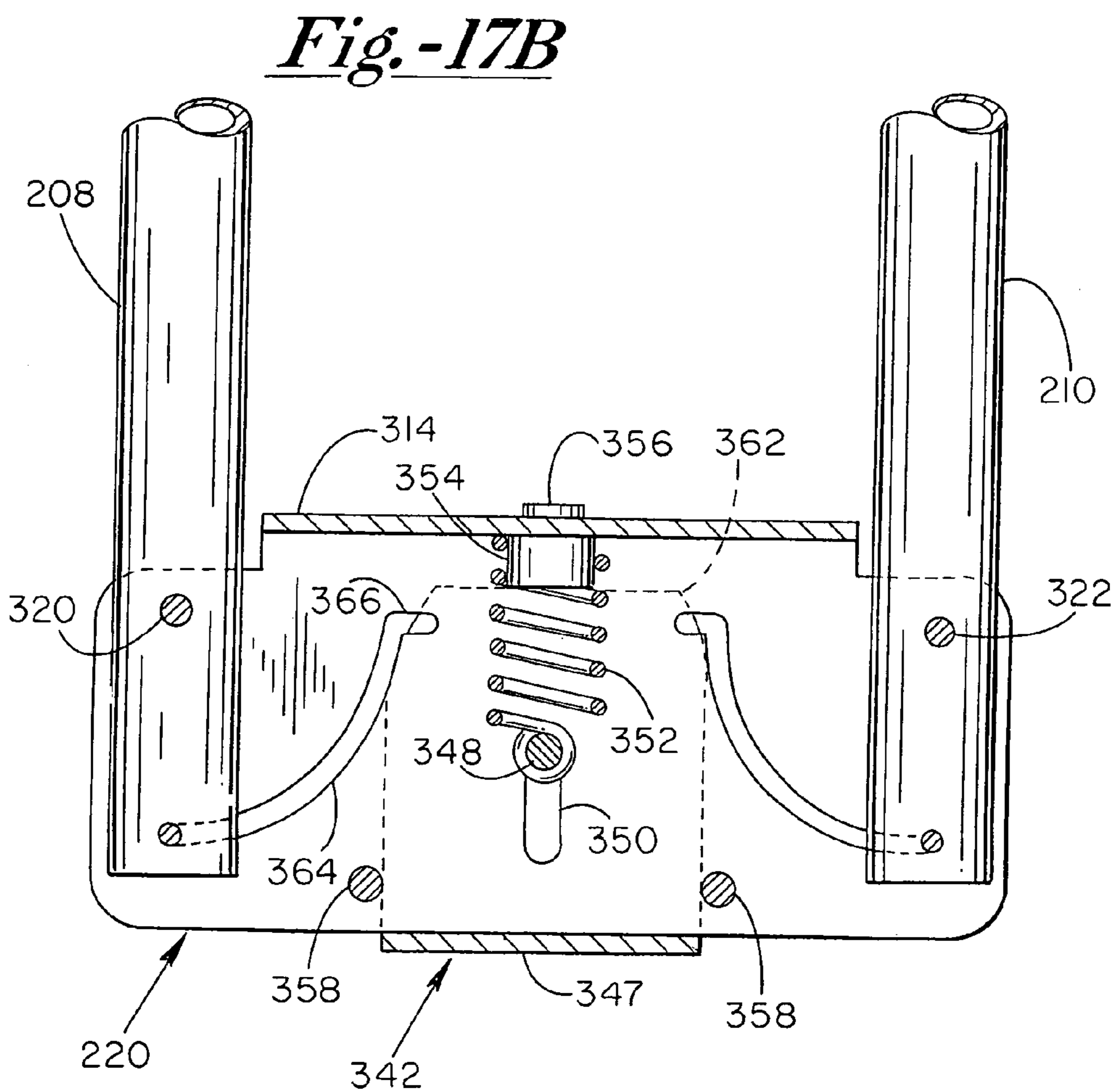
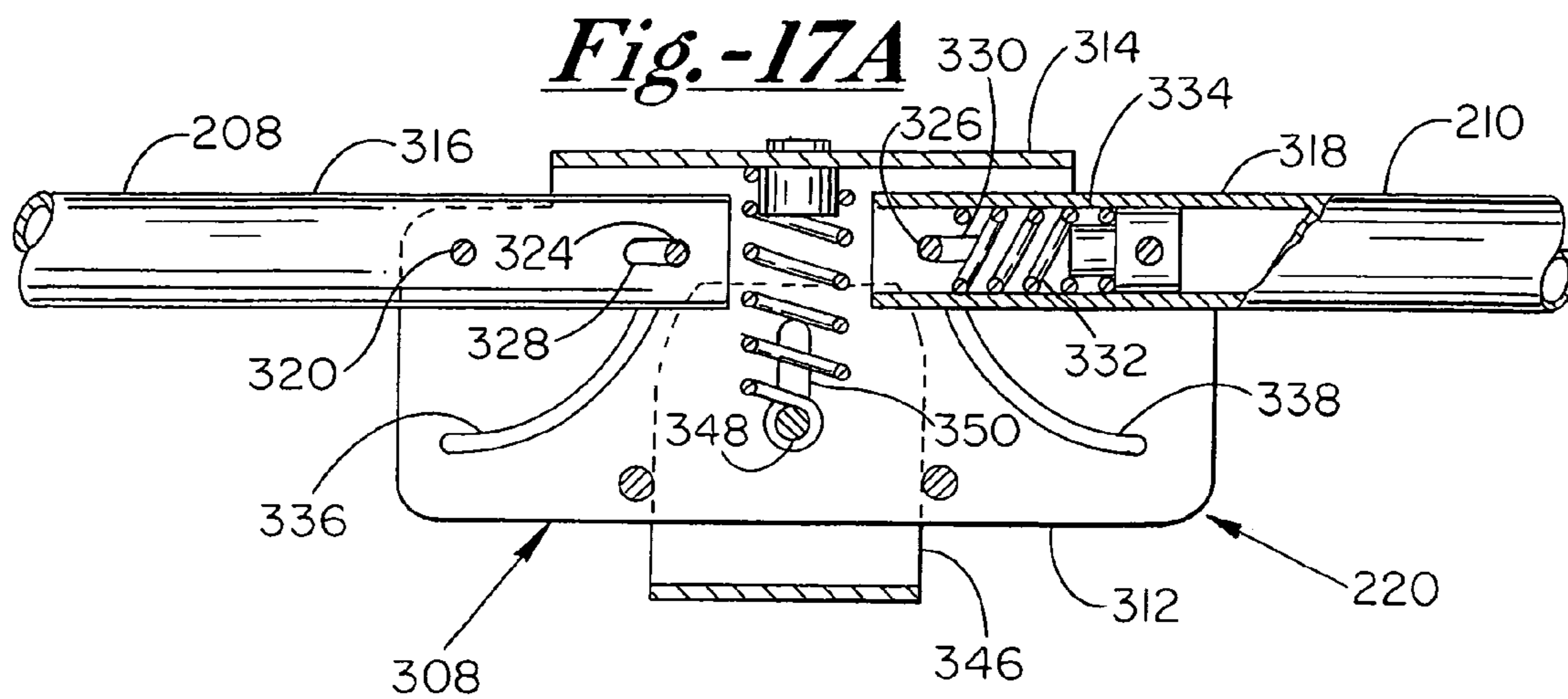
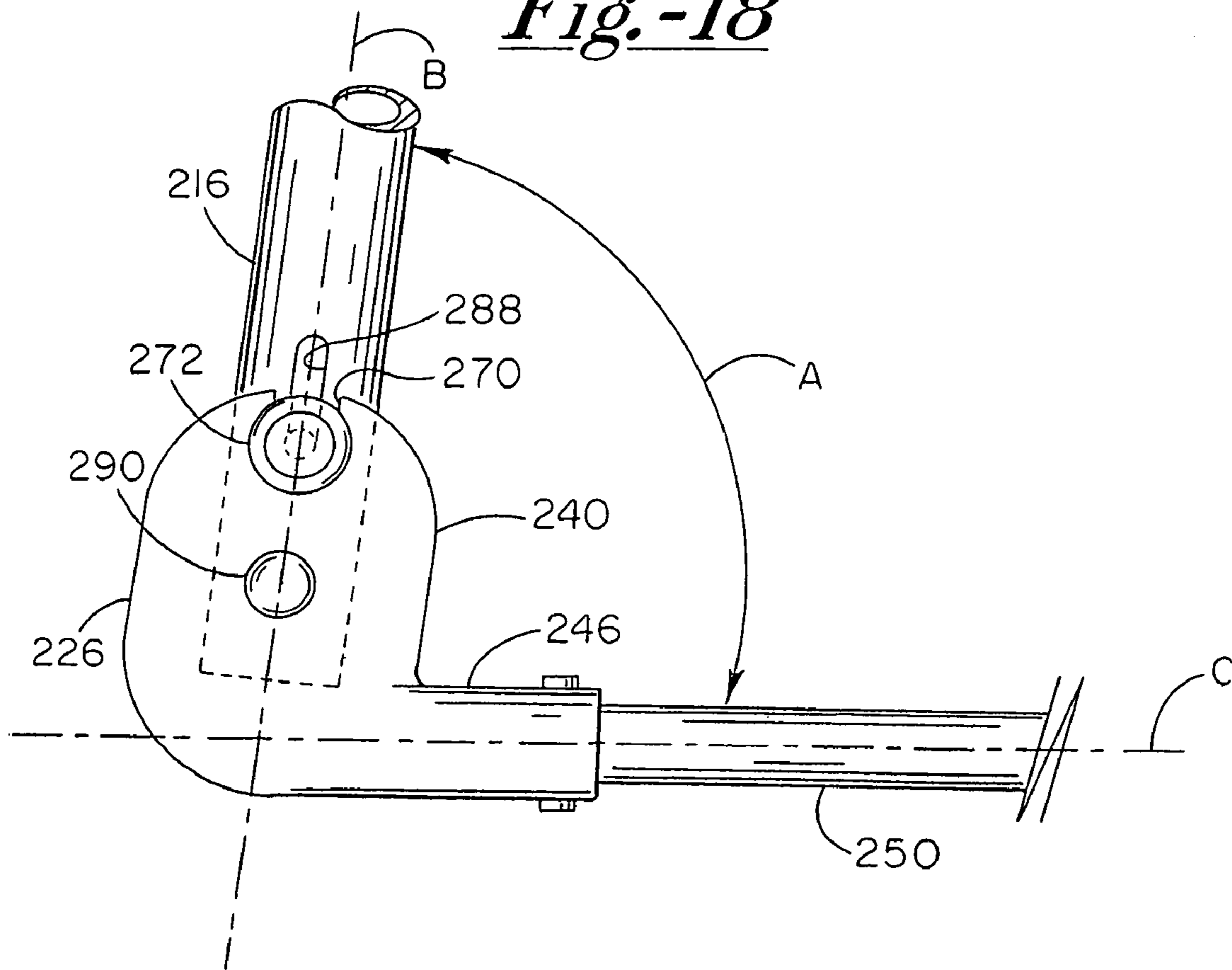
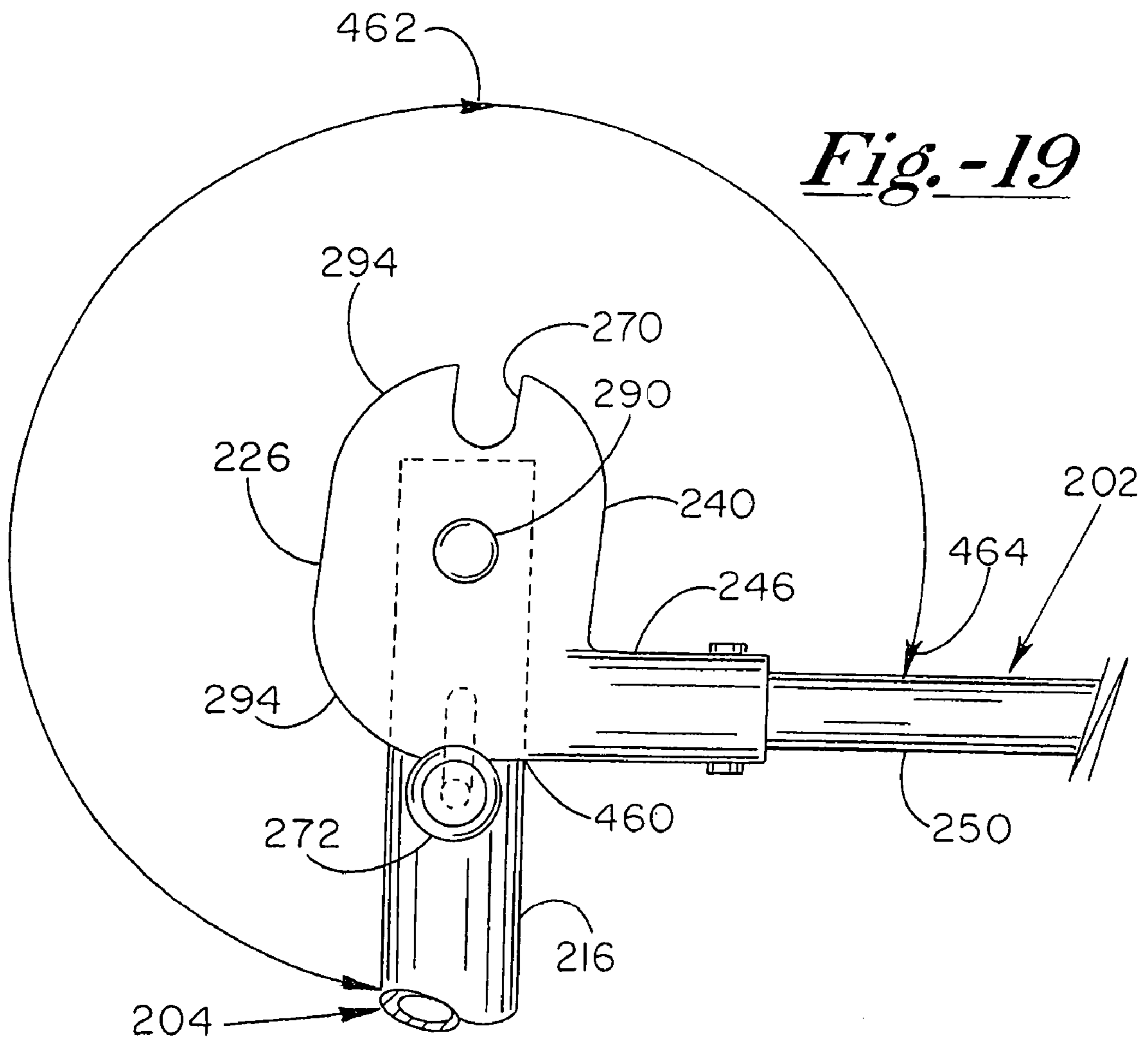
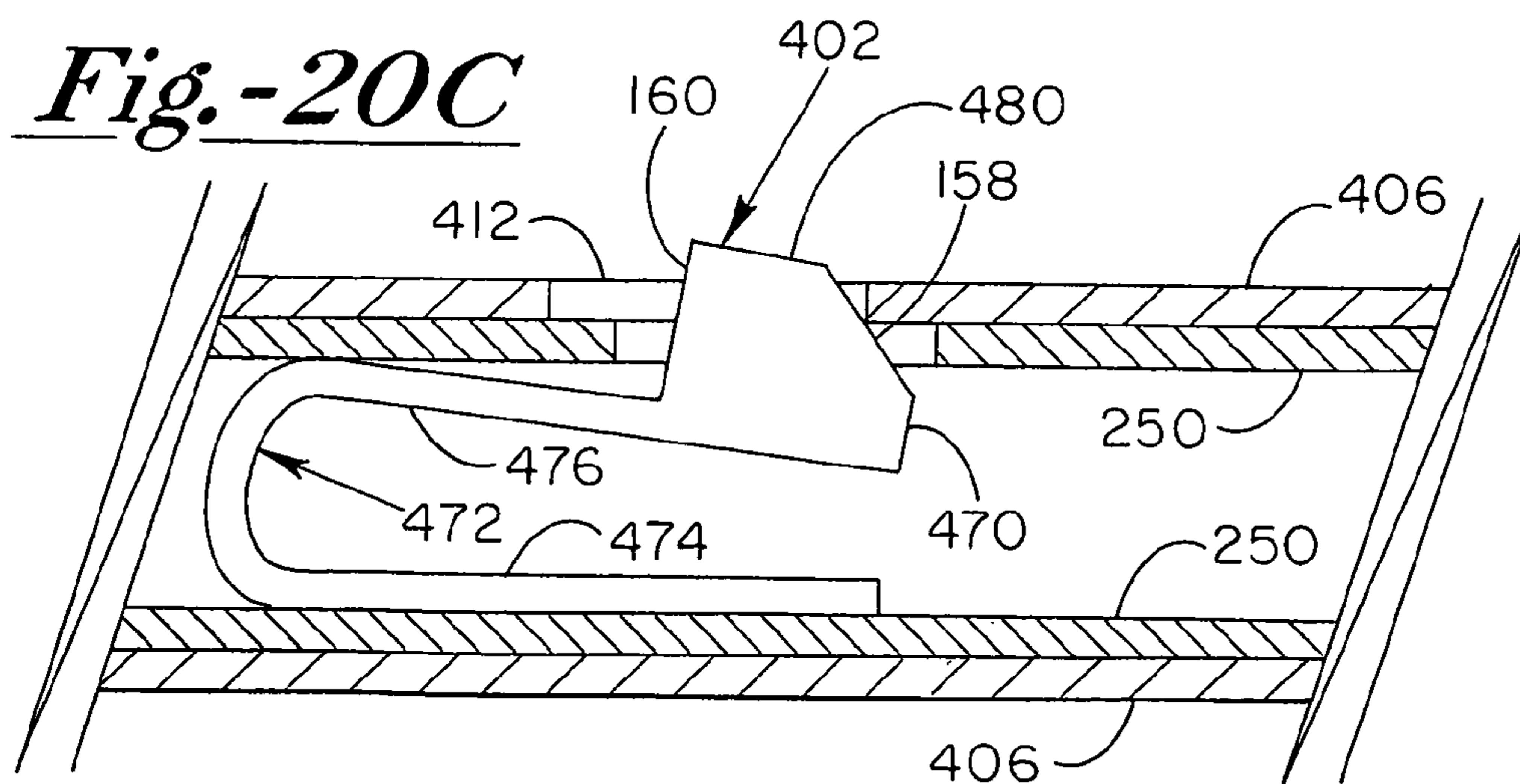
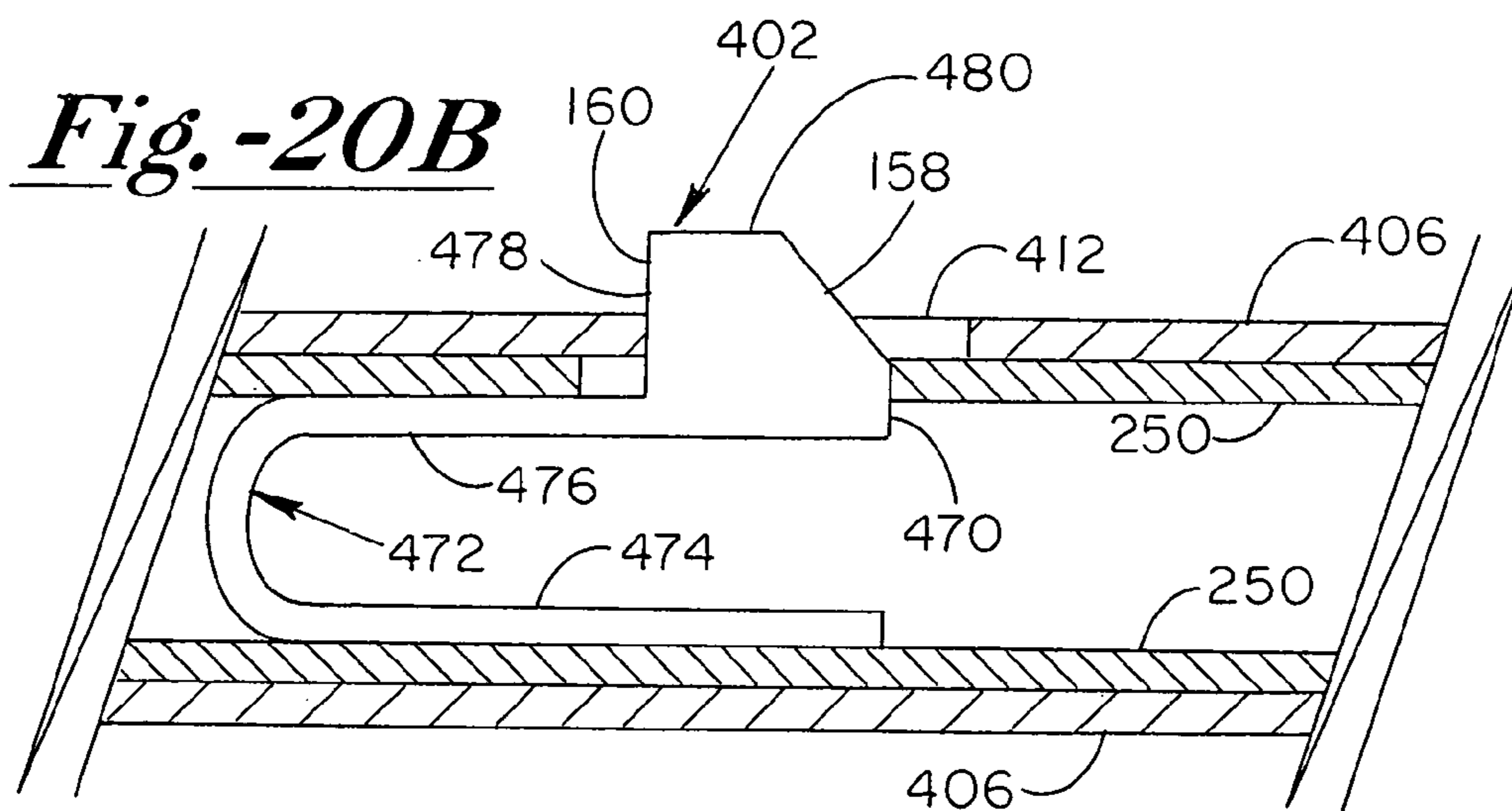
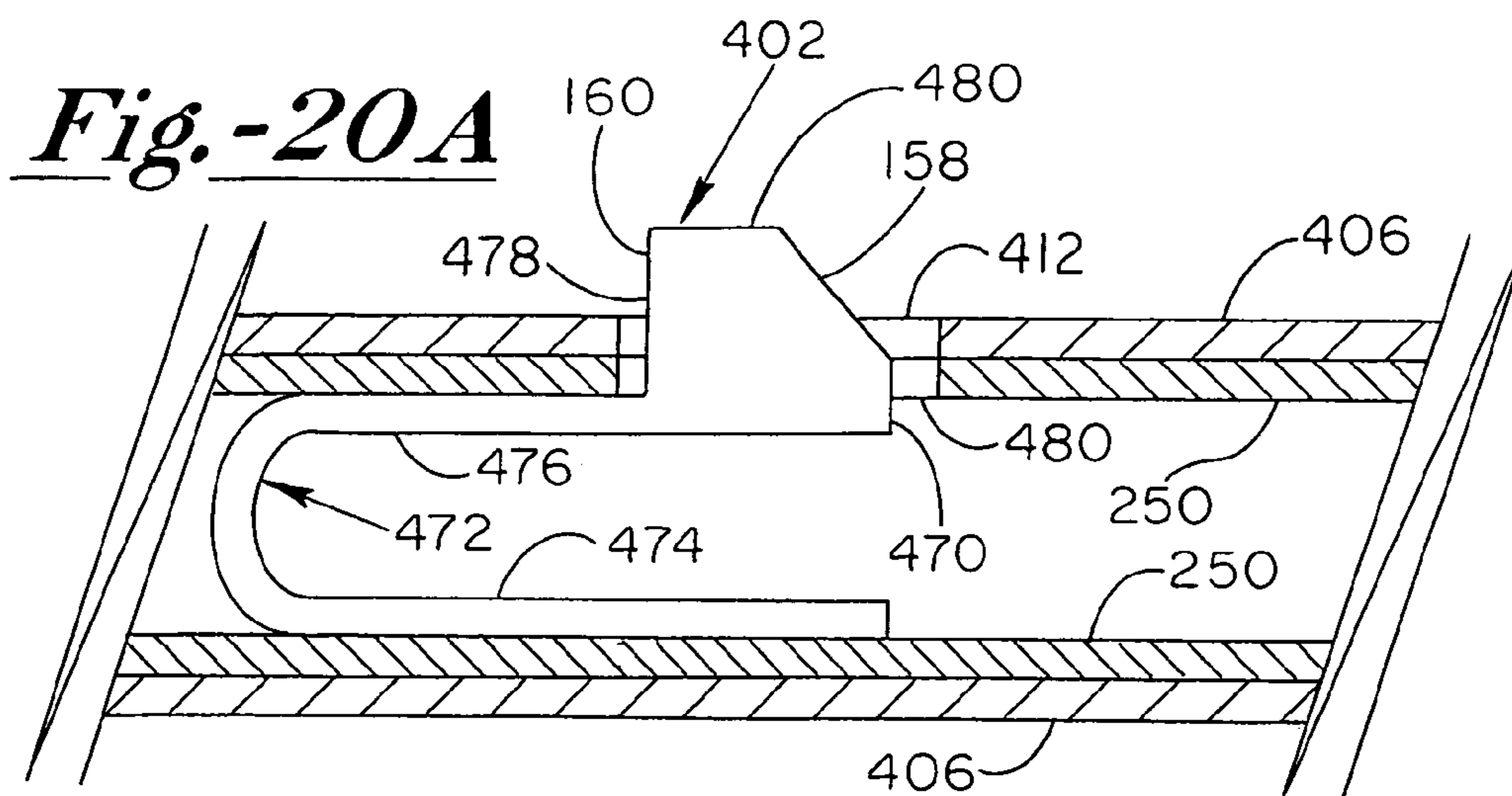

Fig.-18







MATTRESS HUGGING BED RAIL

This is a continuation of U.S. patent application Ser. No. 10/652,296 filed Aug. 29, 2003 and claims the benefit thereof under 35 U.S.C. § 120, which was a nonprovisional of U.S. Provisional Patent Application No. 60/407,369 filed Aug. 30, 2002 and claimed the benefit thereof under 35 U.S.C. § 119(e).

FIELD OF THE INVENTION

The present invention relates particularly to a bed rail and specifically to a bed rail that hugs the mattress to maximize a tight fit between the rail portion and the side of a mattress and to minimize the chance that a child can fall between the rail portion of the bed rail and the side of the mattress.

BACKGROUND OF THE INVENTION

A bed rail is a structure engaged to the side of a bed to prevent a person, especially a child, from rolling out of bed and falling to the floor. A bed rail includes a leg portion that is sandwiched between the mattress and box spring. A bed rail further includes a rail portion that extends from the leg portion and upwardly to and beyond the sleeping surface of the bed. The rail portion forms the rail that prevents the child from rolling out of bed.

A bed rail is intended to provide a safe sleeping environment, particularly for a child. However, the leg portion tends to work its way out from between the mattress and the box spring. As the leg portion works its way out, a gap is created between the side of the mattress and the rail portion of the bed rail. Children have rolled off the bed, have fallen into the gap, and have been entrapped between the bed rail and side of the mattress.

SUMMARY OF THE INVENTION

A feature of the present invention is the provision in a bed rail having a rail portion confronting a first side of a bed and extending upwardly beyond a sleeping surface of the bed and a leg portion extending from the rail portion and running toward a second side of a bed, of a member engaged to the leg portion and adapted for engaging the second side of the bed such that the member and rail portion hug the bed therebetween to minimize a creation of a gap between the rail portion and the first side of the bed.

Another feature of the present invention is the provision in a bed rail having a rail portion confronting a first side of a bed and extending upwardly beyond a sleeping surface of the bed and a leg portion extending from the rail portion and running toward a second side of a bed, of a cover depending from an upper portion of the rail portion and extending over a portion of the sleeping surface of the bed to cover any gap that may be created between the rail portion and the first side of the mattress.

A feature of the present invention is the provision in a bed rail having a rail portion confronting a first side of a bed and extending upwardly beyond a sleeping surface of the bed and a leg portion extending from the rail portion and running toward a second side of a bed, of the rail portion being set at an angle relative to the leg portion so that the rail portion confronts as much as possible the edge of the mattress where the sleeping surface joins the first side of the mattress.

An advantage of the present bed rail is safety. The embodiments of the invention have means for minimizing the creation of the gap between the rail portion and the first side of the mattress.

Another advantage of the present invention is that the bed rail is easy to set up so as to provide a tight fit between the rail portion and the first side of the mattress.

Another advantage of the present invention is that the bed rail is difficult to set up when an attempt is made to create a less tight fit between the rail portion and the first side of the mattress.

Another advantage of the present invention is that the bed rail includes a compact configuration for storage.

BRIEF DESCRIPTION OF THE DRAWINGS

FIG. 1A is a partially section and diagrammatic view of a mattress, box spring, frame, and a prior art bed rail sandwiched between the mattress and the box spring.

FIG. 1B is a side diagrammatic view of the mattress, box spring, frame and prior art bed rail of FIG. 1A.

FIG. 2A is a partially section and diagrammatic view of a hugging bed rail of the present invention sandwiched between a mattress and a box spring and shows a position prior to when the bed rail is tightened to hug the bed.

FIG. 2B shows a perspective view of one embodiment of a counter member for opposing or countering the rail portion of the bed rail and for engaging the second side of the bed.

FIG. 2C shows a perspective view of another embodiment of a counter member for opposing or countering the rail portion of the bed rail and for engaging the second side of the bed.

FIG. 2D shows a perspective view of still another embodiment of a counter member for opposing or countering the rail portion of the bed rail and for engaging the second side of the bed.

FIG. 2E shows a perspective view of yet another embodiment of a counter member for opposing or countering the rail portion of the bed rail and for engaging the second side of the bed.

FIG. 2F is a diagrammatic view of the counter member of FIG. 2E engaging a strap which in turn engages another portion of the bed rail.

FIG. 3A is a top diagrammatic view of a bed with the mattress removed and shows a single counter member engaging the second side of the bed.

FIG. 3B is a top diagrammatic view of a bed with the mattress removed and shows a pair of counter members engaging the second side of the bed.

FIG. 3C is a top diagrammatic view of a bed with the mattress removed and shows a "leg-less" bed rail with two embodiments of counter members where a rigid portion of the leg is deleted and where the "leg" may include only a strap running from the rail portion to the counter member.

FIG. 4A is a diagrammatic perspective view of a bed rail of the present invention wherein the distal ends of the leg portion of the bed rail has apertures for engaging straps that in turn engage counter members.

FIG. 4B is a diagrammatic view of one embodiment of a distal end for the bed rail of FIG. 4A.

FIG. 4C is a diagrammatic view of another embodiment of a distal end for the bed rail of FIG. 4A.

FIG. 4D is a perspective view of the distal end of FIG. 4C.

FIG. 4E is a diagrammatic view of another embodiment of a distal end for the bed rail of FIG. 4A.

FIG. 5A is an end diagrammatic view showing a prior art bed rail and shows how the prior art bed rail may form a gap between the rail portion and the mattress.

FIG. 5B is an end diagrammatic view of another embodiment of the present invention where such embodiment

includes a cover for closing off any gap that may be formed between the rail portion and the mattress of FIG. 5A.

FIG. 5C is a perspective diagrammatic view of the cover of FIG. 5B where the cover is engaged to and depends from an uppermost portion of the rail portion of the bed rail.

FIG. 5D is a perspective diagrammatic view of the cover of FIG. 5B where the cover is engaged to and depends from a section below the uppermost portion of the rail portion of the bed rail.

FIG. 6A is a diagrammatic top view of the cover of FIG. 5B showing how the semi-rigid cover has living hinges or relatively weak sections or relatively less rigid sections extending lengthwise across the cover.

FIG. 6B is a diagrammatic top view of the cover of FIG. 5B showing how the semi-rigid cover has living hinges or relatively weak sections or relatively less rigid sections extending across the width of the cover so as to extend in the direction of the leg portion of the bed rail.

FIG. 6C is a detail end view of the cover of FIG. 5B showing the living hinges.

FIG. 6D is a diagrammatic perspective view of the cover of FIG. 5B having a pivoting arm lock that is raised and lowered to raise and lower the cover.

FIG. 7A is a perspective diagrammatic view of one embodiment of the leg portion for the bed rail of the present invention, where the leg portion includes squared off telescoping portions between the rail portion and the counter member to draw the rail portion and counter member to and from each other.

FIG. 7B is a perspective diagrammatic view of another embodiment of the leg portion for the bed rail of the present invention, where the leg portion includes rounded telescoping portions between the rail portion and the counter member to draw the rail portion and counter member to and from each other.

FIG. 7C is a perspective diagrammatic view of the hugging bed rail of the present invention having one of the telescoping members of FIGS. 7A and 7B and further shows how the counter members may be turned upwardly to engage the mattress instead of the box spring.

FIG. 7D is a perspective diagrammatic view of a button feature of the telescoping leg portions of FIGS. 7A, 7B and 7C, where the button feature permits automatic sliding of the telescoping members relative to each other so as to draw the counter members and rail portion towards each other, and where the button feature permits sliding of telescoping members relative to each other so as to draw the counter members and rail portion apart only upon positive pressure upon the button.

FIG. 8 is a diagrammatic end view of still another embodiment of the present invention where the rail portion of the bed rail is locked at an acute angle relative to the leg portion of the bed rail such that the leg portion of the bed rail does not run parallel to the first side of the mattress.

FIG. 9 is a perspective view of a preferred embodiment of the bed rail of the present invention wherein the leg of the bed rail includes a first embodiment of a counter attachment.

FIG. 10 is a broken apart view of the frame of the bed rail of FIG. 9.

FIG. 11 is a partial, perspective view of the bed rail of FIG. 9 wherein the leg of the bed rail includes a second embodiment of a counter attachment.

FIG. 12 is a perspective view of the bed rail of FIG. 9 and shows the base of the leg without attachment of any of the first or second embodiments of the counter attachment.

FIG. 13 is a perspective view of the bed rail of FIG. 12 in a folded compact position.

FIG. 14A is a side view showing a corner of the frame of the bed rail of FIG. 9 and shows the leg of the bed rail in an operating, folded out position.

FIG. 14B is a view at lines 14B—14B of FIG. 14A.

FIG. 14C is a side view of the corner of the frame of FIG. 14A and shows the leg of the bed rail in a folded position for storage.

FIG. 14D is a view at lines 14D—14D of FIG. 14A.

FIG. 15A is a section view of the corner of the frame of FIG. 14A and shows the leg of the bed rail in an operating, folded out position.

FIG. 15B is a section view of the corner of the frame of FIG. 14C and shows the leg of the bed rail in a folded position for storage.

FIG. 16A is a side view of the hinge mechanism of the bed rail of FIG. 9 and shows top rails of the rail portion of the bed rail in the folded, stored position.

FIG. 16B is a side view of the hinge mechanism of the bed rail of FIG. 9 and shows the top rails of the rail portion of the bed rail in an operating position.

FIG. 17A is a section, partial view of the hinge mechanism of the bed rail of FIG. 9 and shows the top rails of the rail portion of the bed rail in an operating position.

FIG. 17B is a section, partial view of the hinge mechanism of the bed rail of FIG. 9 and shows the top rails of the rail portion of the bed rail in a folded, stored position.

FIG. 18 shows the preferred embodiment for a lower corner or lower connection of the bed rail of FIG. 9 so as to position the rail portion of the bed rail at an acute angle relative to the leg portion of the bed rail.

FIG. 19 shows the preferred lower connection of FIG. 18 and shows how the rail portion 204 may be swung downwardly relative to the leg portion 202 when use of the rail portion 204 is not desired.

FIG. 20A is a section view of the leg portion of FIG. 9 having the preferred embodiment of the one directional quick connect.

FIG. 20B is a section view of the leg portion of FIG. 9 having the preferred embodiment of the one directional quick connect where the one directional quick connect prevents an increase in the length of one of the legs of the leg portion of the present bed rail.

FIG. 20C is a section view of the leg portion of FIG. 9 having the preferred embodiment of the one directional quick connect where the one directional quick connect permits a decrease in the length of one of the legs of the leg portion of the present bed rail.

DESCRIPTION

FIG. 1A shows a prior art bed rail 10 having a leg 12 and a rail portion 14. The leg 12 is sandwiched between a mattress 16 and a box spring 18. The box spring 18 is set on a frame 20 having legs 22. The mattress 16, box spring 18, frame 20 and legs 22 form as a whole a bed 24 having a first side 26 and a second side 28. The prior art bed rail 10 may tend to form a gap 30 between the rail portion 14 and the first side 26 of the bed 24.

FIG. 1B shows that the prior art rail portion 14 includes a frame 32 and a resilient wall 34 engaged to the frame 32 wherein the resilient wall 34 is formed of a resilient sheet material. The wall 34 may alternatively be rigid if desired. The wall 34 may include several rigid components. The wall 34 may include tubing. The wall 34 may be a relatively thick plastic sheet or wall or wall-like member.

FIG. 2A shows one embodiment 40 of the inventive hugging bed rail. Such bed rail 40 includes a rail portion 42

5

pivotaly engaged to a leg portion 44. The leg portion 44 is sandwiched between mattress 16 and box spring 18. The leg portion 44 is engaged to a strap or tether 46 which in turn is engaged to a counter member or cleat 48. Strap 46 is adjustable in length relative to leg portion 44 and/or relative to counter member 48 so that the rail portion 42 and counter member 48 can be drawn toward each other such that the bed rail 40 can hug the mattress 16 to draw the rail portion 42 tightly against the first side 26 of the mattress 16.

FIG. 2B shows T-shaped counter member 48 having a base 50 that fits between mattress 16 and box spring 18 and that includes an aperture 52 for engaging strap 46. Counter member 48 further includes a first upper extension 54 for confronting the second side of the mattress 16 and a second lower extension 56 for confronting the second side of the box spring 18.

FIG. 2C shows an L-shaped counter member 58 having a base 60 that digs in like a cleat between the mattress 16 and box spring 18. Base 60 includes an aperture 62 for engaging a strap such as strap 46. Counter member or counter 58 further includes an extension 64 that is preferably oriented upwardly so as to confront the second side 28 of mattress 16 instead of the second side 28 of box spring 18.

FIG. 2D shows another counter member 66 that includes a distal countering end 68 rounded upwardly to confront the second side 28 of mattress 16. An inner end portion 70 may be engaged to leg portion 44 such as with a strap or tether, telescoping connection members, or with an integral connection. In the case of an integral connection, the distance between the distal countering end 68 and the rail portion 42 is fixed and sized for a particular mattress such as a single, twin, queen or king-sized bed or for some other fixed size such that the rail portion 42 tightly hugs the first side 26 of the particular mattress.

FIG. 2E shows a counter member 72 having an upper portion 74 for confronting the second side 28 of mattress 16 and a lower portion 76 for confronting the second side 28 of box spring 18. Counter member 72 further includes a pair of apertures 78 for receiving a strap, such as strap 46, in a looped fashion, as shown in FIG. 2F.

FIG. 2F shows the counter member 72 of FIG. 2E engaging strap 46. It should be noted that counter member 72 is preferably oriented such that opposing portions of strap 46 lay on top of each other when sandwiched between mattress 16 and box spring 18. However, if desired, counter member 72 can be oriented sideways such that opposing portions of strap 46 lay side by side when sandwiched between mattress 16 and box spring 18.

FIG. 3A shows that bed rail 40 may include two leg portions 44 sandwiched between the mattress 16 and box spring 18 and that each of the leg portions 44 may be strapped, such as with strap 46, to a counter member, such as counter member 48. In such a case, aperture 52 of base 50 may run at 90 degrees relative to the position shown in FIG. 2B and one strap may run from leg portion 44 through aperture 52 to leg portion 44.

FIG. 3B shows that each of the leg portions 46 can be engaged to a respective strap 46 which in turn is engaged to a respective counter member 48.

FIG. 3C shows a "leg-less" bed rail 40 where the legs 44 (or at least the rigid portions or tubular portions of the legs 44) have been removed. Instead, the straps 46 extend directly or substantially directly from the rail portion 42 to the counter or counters 48. In the embodiment of FIG. 3C, a single counter 48 or dual counters 48 may be used.

FIG. 4A shows that the bed rail 40 can have the frame 32 and resilient wall 34 formed of a resilient sheet material.

6

FIG. 4A further shows that the leg portions 44 have distal ends 80 with apertures 82 for engaging straps or tethers such as straps 46. FIG. 4A shows the strap engaging apertures 82 running vertically.

FIG. 4B shows a detail view of distal end 80, aperture 82 and strap 46.

FIG. 4C shows another embodiment for a distal end of leg portion 44 where a distal end 84 is engaged to leg portion 44 via a pin 86 such as a rivet. Distal end 84 has a slot 88 for engaging strap 46. Distal end 84 is a piece for modifying a prior art bed rail, such as bed rail 10. One kit for modifying a prior art bed rail may include a strap, where the strap is engaged to prior art leg portion 12 and then wound about the mattress 16 or box spring 18 or tied to a portion of frame 20 or leg 22. Another kit for modifying a prior art bed rail may include a strap and a counter member, such as for the embodiment shown in FIG. 3A. Another kit for modifying a prior art bed rail may include a pair of straps and a pair of counter members, such as for the embodiment shown in FIG. 3B. These kits may or may not include piece 84.

FIG. 4D shows a detail view of piece 84 that includes a slot 90 for receiving leg portion 44, aperture 92 for receiving pin 86, and strap receiving slot 88.

FIG. 4E shows that strap 46 may be engaged directly to leg portion 44 with a pin 94 such as a rivet.

FIG. 5A shows in detail gap 30 between rail portion 14 and mattress 16.

FIG. 5B shows another embodiment of the present invention where a cover apparatus 100 is disposed between a rail portion, such as rail portion 42, and a sleeping surface 102 of mattress 16. Cover apparatus 100 includes a cover 104 depending from an uppermost portion of bed rail 42, such as an upper horizontally extending portion of frame 32 and being shaped, such as with living hinges, so as to extend downwardly and inwardly to lie on top of sleeping surface 102 to close off any gap 30 that may happen to come into existence.

FIG. 5C shows a perspective view of the cover apparatus 100 of FIG. 5B where the cover 104 depends from an uppermost portion of rail portion 42. A Velcro® connection or similar hook and loop connection may provide for connection between the frame 32, the lock arm 120 and the cover 104 as well as the sleeping surface 102.

FIG. 5D shows that the cover 104 can depend from a position below the uppermost portion of rail portion 42.

FIG. 6A shows that the cover 104 may have living hinges 110. The living hinges 110 are weakened portions of the cover 104 that is preferably formed of a semi-rigid plastic material. The rigid characteristics of cover 104 keep the cover 104 in place even with the weight of a person on the cover 104 and even with the weight of the person being directed on a line running between rail portion 42 and leg portion 44. The flexible characteristics of cover 104 permit a bend to the cover 104 to permit a somewhat comfortable shape to the cover 104. The living hinges 110 provide the curved shape to the cover 104 and further permit the cover 104 to be folded into a compact shape for storage. The living hinges 110 run the length of the cover 104 so as to run in the same direction as the length of the rail portion 42. The cover 104 may be formed of PVC or of a low density plastic. The living hinges may be formed by perforations in the cover 104. If desired, the cover 104 may be formed of a cloth or when the cover 104 is of a sheet material other than cloth, the cover 104 may be sheathed in cloth for comfort against the skin.

Whether the cover 104 is rigid or whether the cover 104 is made of a flexible or cloth or sheet material, the cover 104

may include, such as on its underside, a material that has a high amount of friction with bedding or a mattress or a mattress covering so as to minimize the chances of the covering **104** falling into any gap **30** that may be created. The material having a high amount of friction may be provided by a material such as neoprene, silicone, rubber, or a rubber-based material where such material is nontoxic.

FIG. **6B** shows that living hinges **112** running in the direction of the leg portions **44**. Here the living hinges **112** permit a folding of the cover **104** into a compact shape for storage but do not contribute toward providing the curved comfortable shape shown in FIGS. **5B**, **5C** and **5D**.

FIG. **6C** shows a detail view of the living hinges **110**.

FIG. **6D** shows a pivot lock arm **120** for the cover apparatus **100**. The pivot lock arm **120** includes a pivot **122** joined to frame **32** of rail portion **42**. The pivot lock arm **120** includes a distal end portion **124** that is joined to a distal edge portion **126** of cover **104**. Pivot **122** includes a lock such that a downward operating position (shown in solid lines in FIG. **6D**) of cover **104** may be locked in place on top of sleeping surface **102**. The lock may also be operational when the pivot lock arm **120** is in an upward open position (shown in phantom in FIG. **6D**). Also shown in FIG. **6D** is a pivot structure **130** that may be provided between rail portion **42** and leg portion **44** to permit the bed rail **40** to be folded for storage. The lock arm **120** may pivot for about 180 degrees from a position on sleeping surface **102** to a position on the other side of the rail portion **42**.

FIG. **7A** shows another embodiment of the invention, where leg portion **44** may include telescoping members **140** and **142** to draw the counter member and the rail portion **44** to and away from each other. Telescoping members **140** and **142** are squared off to prevent the members **140**, **142** from spinning relative to each other.

FIG. **7B** shows telescoping members **144** and **146** that are oval or elliptical in section so as to provide a round shape but yet prevent the members **144** and **146** from spinning relative to each other.

FIG. **7C** shows that one telescoping member **140** (or **144**) may be pivotally joined to rail portion **42** and that another telescoping member **142** (or **146**) may include counter member **68**. Counter member **68** may include cap **148**.

FIG. **7D** shows a button **150** extending through a hole **152** formed in member **140** and a hole **154** formed in member **142**. Button **150** includes a base **156** affixed to an inner surface of member **142** and further includes an inclined surface **158** and an upright or confronting surface **160** confronting surfaces of the members **140**, **142** that form the holes **152**, **154**. The provision of the inclined surface **158** on button **150** permits the counter member **68** and rail portion **42** to be drawn towards each other automatically or with little effort. Accordingly, it is relatively easy to make the rail portion **42** fit tightly against the first side **26** of the mattress **16**. The provision of the confronting surface **160** on button **150** permits the counter member **68** to be drawn apart from the rail portion **42** only with the difficulty associated with depressing button **150**. Accordingly, it is relatively difficult to loosen the bed rail **40** and therefore the chances of forming a gap **30** are minimized.

FIG. **8** shows that rail portion **42** (or the plane in which the frame **32** of the rail portion **42** lies) is preferably set at an acute angle **A** relative to leg portion **44** (or at an acute angle to the plane in which the leg portions **44** lie). A pivot mechanism **170** may permit a swinging between the rail portion **42** and, in such a case, such pivot mechanism **170** does not permit a swinging to a right angle arrangement or to a swinging to an obtuse angle arrangement. Preferably, the

angle between rail portion **42** and leg portion **44** is between 70 and 89 degrees, more preferably between 70 and 88 degrees, even more preferably between 70 and 87 degrees, yet more preferably between 70 and 86 degrees, and most more preferably between 70 and 85 degrees. The provision of an acute angle between the rail portion **42** and leg portion **44** works to close off any gap **30** and sets the rail portion **42** as close to the sleeping surface **102** as possible. FIG. **8** shows the most preferred angle **B** of five degrees (where angle **A** is 85 degrees) where angle **B** defines the relationship between rail portion **42** and a plane parallel to the first side **26** of mattress **16**. The button **150** and its cooperating apertures may be referred to as a one directional quick connect.

As to rail portion **42**, as to leg portion **44**, as to frame **32**, as to wall **34**, as to how rail portion **42** and leg portion **44** are swingable to each other and as to how rail portion **42** and leg portion **44** may be foldable or collapsible to a stored position, the Wu U.S. Pat. No. 5,671,490 issued Sep. 30, 1997 is hereby incorporated by reference in its entirety.

It should be noted that the present bed rail **40** may be engaged to only a mattress or to only a mattress and a frame. The frame may or may not have slats. It should be noted that leg **44** may be broad or paddle-shaped so as to rest upon slats instead of falling through the slats. Slats may be used where no box spring is used.

FIG. **9** shows a bed rail **200**. Bed rail **200** generally includes a leg portion **202** and a rail portion **204**.

As shown in FIG. **10**, rail portion **204** includes a frame assembly **206**. Frame assembly **206** includes upper rails or tubes **208**, **210**, lower rails or tubes **212** and **214**, and side rails or tubes **216** and **218**. Upper rails **208** and **210** are interconnected via a hinge mechanism **220**. Frame assembly **206** further includes respective first and second upper corner two point connections **222**, **224** and first and second lower corner three point connections **226**, **228**.

Distal ends or distal end portions of upper tubes **208**, **210** are pivotally affixed via respective pins **230**, **232** to upper corner connections **222**, **224** such that tubes **208**, **210** swing relative to tubes **216**, **218**. Such relative swinging of tubes **208**, **210**, **216** and **218** occurs in generally the same plane. An inner portion **234** of each of the corner connections **222**, **224** are U-shaped in cross section to permit the tubes **208** and **210** to swing relative to corner connections **222**, **224** and toward tubes **216** and **218**.

Upper ends or upper end portions of side tubes **216**, **218** are rigidly affixed, with no pivotal swinging and no axial sliding, in a cylindrical receptacle formed in an outer portion **236** of each of the corner connections **222**, **224**. The cylindrical receptacle is a non-through hole. Each of the upper end portions of the side tubes **216**, **218** are fixed in their respective cylindrical receptacles with a pin. Such a pin is preferably a spring biased button which, upon being pushed into its respective side tube **216**, **218**, permits the respective side tube **216**, **218** to be withdrawn out of the cylindrical receptacle for disassembly and then snapped back in for reassembly. Such is preferable because this allows the sheet wall **370** to be easily taken off and placed back on the frame assembly **206**.

Each of the lower corner connections **226**, **228** is a three point connection and includes a molded body **240** that is integral and one-piece. Body **240** includes a pair of opposing, spaced apart sidewalls **242**, **244** where sidewall **242** is an outer sidewall and where sidewall **244** is an inner sidewall. Sidewalls **242**, **244** lead integrally into a female receptor **246** for a distal end or distal end portion **248** of base leg sections **250** of the leg portion **202** of the bed rail **200**.

Female receptor **246** is oblong in section to minimize an axial spinning of base leg sections **250** relative to the lower connections **226**, **228** and thus to minimize an axial spinning of the base leg sections **250** relative to the rail portion **204**. Base leg section **250** is rigidly fixed in receptor **246** and to body **240** via a pin **252**. It should be noted that molded body **240** is preferably reinforced with a steel bracket having steel plate portions **253** engaged on the inner sides of sidewalls **242**, **244**. Steel plate portions **253** are interconnected via an integral bracket **255**.

Body **240** further includes a cradle **254** for engaging the distal ends or distal end portions **256**, **258** of lower tubes **212**, **214**. Cradle **254** is one-piece and integral with body **240** such that cradle **254** is one-piece and integral with female receptor **246**. Cradle **254** is a semi-circular open end receptor having a pair of aligned through holes **260**. Holes **260** engage opposing ends of an outer two ended button **262** which is found on distal end portion **256** of lower tube **212** and which is further found on distal end portion **258** of lower tube **214**. Each of the ends of button **262** extends, in the biased and locked position, beyond the outer diametrical surface of its respective tube **212**, **214** such that each of the ends of button **262** can engage holes **260**. Each of the ends of button **262** is resiliently depressable or pushable radially into tube **212** or **214** such that the absolute end of button **262** is at or within the outer diametrical surface of tube **212**, **214** such that the button **262** can disengage from holes **260**. Outer two ended buttons **262** may be operated directly such as by sliding a fingernail between cradle **254** and the end of the button **262**. More preferably, each of the outer two ended buttons **262** is operated by a respective inner two ended button **264** that is not engaged by cradle **254** and that lies at an accessible location outside of cradle **254** when tubes **212**, **214** are engaged by cradles **254**. Each of the ends of buttons **262**, **264** extends through openings formed in tubes **212**, **214**. The structural arrangement for buttons **262**, **264** includes a C-shaped flat spring pinched resiliently within each of the distal end portions **256**, **258** of tubes **212**, **214**. Each of the ends of the C-spring includes one end of button **262** and one end of button **264** such that a pushing upon one end of inner button **264** draws the respective, same sided outer button **262** inwardly. Hence a pinching of the ends of inner button **264** radially inwardly also draws the outer ends of button **262** radially inwardly.

Each of the sidewalls **242**, **244** includes an upper open ended slot or detent **270** for receiving a roller **272** rotatably engaged on a pin **274**. Pin **274** in turn is affixed to, and extends at a right angle to, a spring biased plunger **276** engaged within each of the side tubes **216**, **218**. As shown in FIG. **15A** and **15B**, a first end or base **279** of plunger **278** is rigidly fixed to its side tube **216**, **218** with a pin **280**. A coil spring **282** extends from base **279** to a piece **284** having a portion set within the coil spring **282** and having a disk portion slidingly engaging the inner diametrical surface of tube **216** or **218**. Piece **284** leads into a projection **286** which has a through hole formed therein for pin **274**. Piece **284** and projection **286** may be molded as one part so as to be one-piece and integral. A pair of slots **288** are formed in each of the tubes **216**, **218**. Slots **288** of tube **216** are aligned with each other and slots **288** of tube **218** are aligned with each other such that pin **274** can travel the length of slots **288** and in the axial direction of tubes **216**, **218**.

Body **240** is pivotally fixed to side tubes **216**, **218** via a pin **290** engaged to each of the sidewalls **242**, **244**. Body **240** is fixed or locked in position to side tubes **216**, **218** by the rollers **272** being engaged in the detents **270**. In the locked position, the plunger **278** is biased to its extended position

by the coil spring **282** and keeps the rollers **272** locked into the detents **270**. To unlock the side tubes **216**, **218** from the lower corner connections **226**, **228** and hence to unlock rail portion **204** from the leg portion **202**, the rollers **272** are drawn by hand axially toward a central portion of tubes **216**, **218** to draw the rollers **272** out of the detents **270**. When the rollers **272** are disengaged from the detents **270**, the side tubes **216**, **218** are relatively swingable relative to the leg portions **202**. This relative swinging permits: 1) the rail portion **204** to be swung downwardly to a right angle relative to the leg portion **202** to confront side **26** of box spring **18** so that one can have relatively easy access to get in and out of the bed **24**, as shown in FIG. **19**; 2) the rail portion **204** to be swung upwardly to an upright position and right angle position relative to the leg portion **202**, whereupon the rollers **272** snap into the detents **270** under the plunger bias, as shown in FIG. **18**; 3) the side tubes **216**, **218** to be swingable relative to the legs **250** such that the legs **250** can be drawn upward relative to the side tubes **216**, **218** for storage, as shown in FIG. **14C**; and 4) the side tubes **216**, **218** to be swingable relative to the legs **250** such that the legs **250** and side tubes **216**, **218** can be unfolded from a stored compact arrangement and locked into an operating position.

Sidewalls **242**, **244** of body **240** have a partially curved and partially linear perimeter **292** upon which the rollers **272** roll when the bed rail **200** is being folded into or from a stored, compact arrangement. Sidewalls **242**, **244** have a partially curved and partially linear perimeter **294** upon which the rollers **272** roll when the rail portion **204** is being dropped against the side **26** of the box spring **18** or when the rail portion **204** is being swung up from side **26** of box spring **18** to an upright operating position against the side **26** of the mattress **16**. FIG. **19** shows the downwardly swung position of the rail portion **204**.

Lower tubes **212** and **214** engage each other with a male/female connection. Lower tube **212** includes an inner female end portion **300** having a hole or button receptor **302**. Lower tube **214** includes an inner male end portion **304** having a button **306** that is biased radially outwardly so as to snap into hole **302** and lock the tubes **214**, **216** relative to each other such that the tubes **214**, **216** cannot spin relative to each other and such that the tubes **214**, **216** cannot slide in the axial direction relative to each other until the button **306** is pressed, whereupon the tubes **212**, **214** can be disengaged from each other.

Lower tubes **212**, **214**, when fixed to each other and set in cradles **254**, provide a rigid lower rail for the rail portion **204**; side tubes **216**, **218**, when the rollers **272** are locked in the detents **270**, provide rigid side rails for the rail portion **204**; and upper tubes **208**, **210**, when the hinge mechanism **220** is locked, provide a rigid upper rail for the rail portion **204**, whereby a relatively rigid frame assembly **206** is provided for rail portion **204**.

As shown in FIGS. **16A**, **16B**, **17A** and **17B**, hinge mechanism **220** includes a housing **308** having a front wall **310** and a rear wall **312** that are interconnected with a semi-cylindrical top portion **314** such that housing **308** takes generally an inverted U-shape. Proximal end or proximal end portions **316**, **318** of upper tubes **208**, **210** are swingably affixed to housing **308** via a pins **320**, **322** engaged between front wall **310** and rear wall **312**. Disposed inwardly from the pins **320**, **322** are pins **324**, **326** running parallel to pins **320**, **322**. Pins **324**, **326** are mounted in proximal end portions **316**, **318** and extend at a right angle from the tubes **208**, **210** via slots **328**, **330** in the proximal end portions **316**, **318**. Pins **324**, **326** are biased in the inwardly direction toward a locked position (toward the inner axial end of each

respective tube 208, 210) via a coil spring 332 mounted in each respective proximal end portion 316, 318. Coil spring 332 is fixed under tension between its respective pin 324, 326 and an end piece 334 fixed in its respective tube 208, 210. End portions of pins 324, 326 ride in respective tracks 336, 338 formed in the front wall 310 and rear wall 312 of housing 308. In other words, a track 336 in front wall 310 is aligned with a track 336 formed in the rear wall 312, and these tracks 336 engage outer end portions of pin 324. Further, a track 338 formed in front wall 310 is aligned with a track 338 formed in rear wall 312, and these tracks engaged outer end portions of pin 326. Each of the ends of pins 324, 326 has a roller 340 rotatably mounted thereon such that hinge mechanism 220 includes four rollers 340.

Hinge mechanism 220 includes an unlocking mechanism 342 that unlocks hinge mechanism 220 by bringing pressure to bear on the four rollers 340. Unlocking mechanism 342 is a generally U-shaped piece having a front wall 344 confronting and sliding upon front wall 310 of housing 308 and further having a rear wall 346 confronting and sliding upon rear wall 312 of housing 308. A bottom portion 347 interconnects the front wall 344 and rear wall 346. Bottom portion 347 of unlocking mechanism 342 opposes top portion 314 of housing 308 of hinge mechanism 220 to provide squeezing surfaces when unlocking mechanism 342 and housing 308 are drawn relatively together. A pin 348 extends between front and rear walls 344, 346 and rides in slots 350 formed in each of the front wall 310, 312 of housing 308. Pin 348 and hence the unlocking mechanism 342 as a whole is biased toward a locked position by a coil spring 352 fixed under tension between pin 348 and an end piece 354 fixed to top 314 of housing 308 via pin 356. Unlocking mechanism 342 further includes guide pins 358 rotatably engaged in holes formed in the front wall 344 and rear wall 346 of unlocking mechanism 342 for engaging linear portions 360 of a periphery of front wall 344 and rear wall 346. Rollers 340 engage curved or tapering portions 362 of the front wall 344 and rear wall 346.

Each of the tracks 336, 338 of hinge mechanism 220 includes a curved or arc track portion 364 having as its center or pivot point pin 320 or 322. Pins 324, 326 ride in the arc track portion 364 when the rail portion 204 is being folded or unfolded. Each of the tracks 336, 338 further includes a linear track portion or detent 366 in communication with the arc track portion 364. Pins 324, 326 snap into the detent 366 when the rail portion 204 is folded to an operating position. Pins 324, 326 are forced out of the detent 366 and into the curved track portion 364 by the curved periphery portion 362 when the unlocking mechanism 342 is squeezed against the bias of the coil spring 352.

FIGS. 16B and 17A show the hinge mechanism 220 in a locked position. Pins 324 and 326 are resiliently pressed into the detents 366 by the bias of the coil springs 332. Rollers 340 (on the ends of the pins 324, 326) confront the curved periphery portions 362 of the unlocking mechanism 342. Pin 348 of the unlocking mechanism 342 is resiliently brought to bear against the root base point of slot 350 by coil spring 352. In such locked position, upper tubes 208, 210 are locked in a straight line relative to each other.

To unlock the hinge mechanism 220 so as to permit the upper tubes 208, 210 to swing relative to each other to a folded position where the upper tubes lie generally parallel to each other, unlocking mechanism 342 and housing 308 are squeezed relative to each other so as to draw the bottom portion 347 of the unlocking mechanism 342 toward the top portion 314 of housing 308. When the unlocking mechanism 342 is drawn upwardly, the curved periphery portions 362

are drawn against the rollers 340, which in turn pushes the pins 324, 326 against the bias of the coil springs 332 out of the detents 366 and into the curved track portions 364, thereby permitting each of the tubes 208, 210 to be swung on the pivot pins 320, 322. FIG. 17B shows the curved periphery portions 362 relative to the detents 366 when the unlocking mechanism 342 is fully squeezed. Upon a pivoting of tubes 208, 210 and upon a release of the unlocking mechanism 342, the unlocking mechanism 342 returns under the bias of the coil spring 352 to the position shown in FIG. 16A. The root base points of the arc track portions 364 act as a stop for pins 324, 326 and prevent a further swinging of the tubes 208, 210 beyond parallel relationship.

To lock the hinge mechanism 220 from the position shown in FIG. 16A, the tubes 208, 210 are swung on their pivots 320, 322 such that the pins 324, 326 ride in the curved track portions 364 toward the detents 366. Upon reaching the detents 366, the pins 324, 326 snap into the detents under the bias of the coil springs 332, whereupon the tubes 208 and 210 are locked relative to each other and whereupon the rollers 240 confront the curved periphery portions 362 for a subsequent unlocking operation.

As shown in FIG. 9, rail portion 204 further includes a fabric wall 370 engaged to the frame assembly 206. Fabric wall 370 generally includes a tubular periphery 372 and an interior, preferably nylon, mesh 374. Tubular periphery 372 engages frame assembly 206. Interior mesh 374 is engaged by the tubular periphery 372. Tubular periphery 372 includes a pair of side wall sections 376, 378 for engaging side tubes 216 and 218, a lower wall section 380 for engaging lower tubes 212, 214, and an upper wall section 382 for engaging upper tubes 208, 210. Each of the side wall sections 376, 378 is a sheet of nylon folded over to form a tubular portion 384 formed by stitching 386. Side tubes 216, 218 run through the tubular portions 384. Inner edges of side wall sections 376, 378 are engaged by stitching 387 to side edges of mesh 374. Lower wall section 380 is a sheet of nylon folded over to form a tubular portion 388 through which lower tubes 212, 214 run. Tubular portion 388 is formed by stitching 390 that also engages lower wall section 380 to the lower edge of mesh 374. Upper wall section 382 includes a sheet of nylon folded over to form a tubular portion 392 through which upper tubes 208 and 210 run. Tubular portion 392 is formed by stitching 394 that also engages the upper wall section 382 to the upper edge of mesh 374. Tubular portion 392 is of sufficient size such that, when fabric wall 370 is removed from frame assembly 206, the hinge mechanism 220 can slide through the tubular portion 392. Upper wall section 382 further includes a sheet of cushion 394 or resilient material engaged to the underside of the sheet of nylon so as to pad the upper tubes 208, 210 and hinge mechanism 220 relative to a person sleeping in bed 24. Besides being engaged to the nylon mesh 374, each of the wall sections 376, 378, 380 and 382 are engaged to adjacent wall sections via stitching 386, 390 and 394 so as to provide strength to the fabric wall 370. In other words, lower wall section 380 is engaged by stitching 386 and 390 to side wall sections 376, 378, and upper wall section 382 is engaged by stitching 386 and 394 to side wall sections 376, 378. When rail portion 204 is swung relative to leg portion 202, tubular portion 388 pivots relative to tubes 212, 214.

Fabric wall 370 is removable from frame assembly 206 by 1) first depressing a button in the upper ends of side tubes 216, 218 so as to disconnect the side tubes 216, 218 from the upper connections 222, 224, 2) then sliding the side wall sections 376, 378 off the side tubes 216, 218, 3) then sliding the upper wall section 382 off of tubes 208 and 210 and

hinge mechanism 220, and 4) then sliding the lower wall section 380 off tubes 212, 214. Such steps need not take place in such order; however, prior to removing upper wall section 382, the side tubes 216, 218 are disconnected from the upper connections 222, 224.

As shown in FIG. 9, bed rail 200 generally includes a leg portion 202 and a rail portion 204. Leg portion 202 includes the base leg section 250 having the proximal end portion 248 which is engaged in lower connections 226, 228 with pin 252. As noted above, female receptor 246 is oblong in section and base leg section 250 is oblong in section to minimize relative rotation between female receptor 246 and base leg section 250. As shown in FIG. 10, base leg section 250 includes a distal end male portion 400 having a button 402. Button 402 is inclined on its distal side 158 and runs vertically on its proximal side 160. Base leg section 250 is tubular and is preferably formed of steel.

As shown in FIGS. 9 and 10, leg portion 202 may include a first embodiment of a counter attachment. This counter attachment or counter section, designated by reference numeral 404, includes a generally linear female tube portion 406 having a proximal end portion 408 and a distal end portion 410. Proximal end portion 408 is a female receptor for male portion 400 of base leg section 250 and includes oblong slots 412 for engaging button 402. Slots or detents 412 are arranged in the axial direction along the upper side of counter attachment 404 and provide for length adjustment of leg portion 202 by selective engagement with button 402.

Counter attachment 404 further includes a counter 414 extending at a generally right angle relative to generally linear tube portion 406. Counter 414 extends integrally from distal end portion 410 and is one-piece with linear tube portion 406. Counter 414 includes a cap 416. Counter 414 is rigid relative to generally linear tube portion 406 and keeps the mattress 16 sandwiched between the rail portion 204 and the counter 414.

As shown in FIG. 7D and FIG. 10, button 402 includes the structure of button 150 and includes a vertical side 160 and an inclined or tapering side 158, where vertical side 160 is faces the rail portion 204 and where the tapering side 158 faces the counter 414 such that leg portion 202 may be decreased in length with a relative minimum amount of effort and such that leg portion 202 may be increased in length only with a relative maximum amount of effort. Tapering side 158 is a quick connect mechanism. Vertical side 160 is not a quick connect mechanism and requires hand operation directly on the button for operation. In other words, with such a structure provided to button 402, namely tapering side 158, counter attachment 404 is readily slid onto base leg portion 250 with no need to depress button 402 such that the rail portion 204 can readily hug the first side 26 of mattress 16 and such that there is no gap between the rail portion 204 and the first side 26 of mattress 16. With such a structure provided to button 402, namely vertical side 160, leg portion 202 cannot be increased in length, which would create a gap between the rail portion 204 and the first side 26 of mattress 16, without depressing button 402 because the vertical side 160 prevents counter attachment 404 from sliding out of base leg section 250.

It should further be noted that, with the counter attachment 404 and the base leg section 250 being oblong in section, rotation between the counter attachment 404 and base leg section 250 is minimized. Further, as noted above, rotation between base leg section 250 and its respective connection 226, 228 having oblong female receptor 246 is minimized. Hence counter 414 is maintained in an upright position against the second side 28 of mattress 16.

The oblong shape to female receptor 246, base leg section 250, counter attachment 404 and counter attachment 420 further maximizes the flatness of such members so as to minimize any bumps that may manifest themselves at the upper surface of the mattress 16.

As shown in FIG. 11, leg portion 202 may include a second embodiment of a counter attachment. This counter attachment, designated by reference numeral 420, includes a tubular medial section 422 and a tubular counter section 424. Medial section 422 includes a proximal female end 426 having a circular hole 428 for reception of button 402 of base leg section 250. Medial section 422 includes a distal end female portion 430 having a set of oblong slots or detents 432 arranged in the axial direction on the upper side of medial section 422. Openings 432 (oblong slots) are of a different shape than opening 428 (a circular hole) to make assembly of the bed rail 200 user friendly, based upon sight, for the customer.

Tubular counter section 424 includes a proximal end male portion 434 having a button 436 that includes the structure of button 150 of FIG. 7D. That is, button 436 includes a vertical side 160 and a tapering side 158 such that counter section 424 can be easily slid into the medial section 422 so as to decrease the effective length of one of the legs of leg portion 202. Button 436 hence selectively cooperates with one of the slots or detents 432 of medial section 422. Counter section 424 further includes a distal end portion 438 and a counter 440 extending at a right angle from the distal end portion 438. A plastic safety cap 442 caps the end of the counter 440. Counter 440 is rigid relative to distal end portion 438. Vertical side 160 of button 436 faces counter 440. Tapering side 158 of button 436 faces the absolute proximal end of counter section 424 so as to face the rail portion 204.

As with counter attachment 404, each of medial section 422, counter section 424 and base leg section 250 is oblong in cross section such that rotation among the sections 422, 424 and 250 is minimized so as to keep counter 440 in an upright position on the second side 28 of mattress 16.

As with counter attachment 404, merely a relative minimum amount of effort is required to decrease the effective length of counter attachment 420, given the relative orientations of tapering sides 158 of buttons 436 and 402, such that the creation of any gap between the bed rail 200 and the first side 26 of mattress 16 is prevented. As with counter attachment 404, a relative maximum amount of effort is required for increasing the effective length of counter attachment 420 because of the relative orientations of vertical sides 160 of buttons 436 and 402 so as to minimize the creation of any gap between the bed rail 200 and the first side 26 of mattress 16.

Counter attachment 404 may be utilized for a relatively small bed. Counter attachment 420 may be utilized for a relatively large bed.

It is noted that, to increase the length of counter attachments 404 and 420, effort is maximized in at least two ways. First, to gain access to the counter attachments, 404 and 420, the mattress 16 must be lifted off the counter attachments 404 and 420. Since the counters 414, 440 are maintained at an upright position, it is difficult to simply pull the bed rail 200 from between the mattress 16 and the box spring 18. Second, once access is gained to the counter attachments 404 and 420, buttons 402, 436 must be depressed and then redepressed for each of their respective slots 412, 432 while the female section 406 is being removed from section 250 (or slid outwardly relative to each other) and while sections 422 and 424 are being separated (or slid outwardly relative

to each other). Such a depression and a redepression takes time and effort and such a depression and redepression is preferred. Buttons **402** and **436** are resilient and spring based such that their bias is to the outer locked position and such buttons **402** and **436** pop out of slots **412** and **432** as sections are being slid relative to each other.

FIG. **12** shows the bed rail **200** in the process of being folded to a compact configuration. Leg portion **202** and rail portion **204** have been swung relatively to each other by the operation of connections **226** and **228** such that base leg sections **250** are disposed generally parallel to side tubes **216** and **218**. From the position shown in FIG. **12**, lower tubes **212**, **214** are disconnected from the connections **226**, **228** and the lower tubes **212**, **214** are slid out of the lower wall section **380**. Then the hinge connection **220** is squeezed so as to operate the unlocking mechanism **342**. Indicia **450** is provided on the upper wall section **382** to indicate the location and general structure of the hinge mechanism **220** and unlocking mechanism **342**. An arrow indicia **452** is provided on the upper wall section **382** below indicia **450** and points at indicia **450** to indicate the direction the unlocking mechanism **342** slides to unlock the hinge mechanism **3220**. Upon an unlocking of the upper tubes **208**, **210** relative to each other, the outer ends of the bed rail **200** can be swung upwardly with the base leg sections **250** to the compact storage configuration shown in FIG. **13**.

In a stored configuration as shown in FIG. **13**, bed rail **200** with each of the counter attachments **404** and **420** can fit in a nylon drawstring bag where the bag measures about seven inches in diameter and about 30 inches in depth.

FIG. **18** shows the preferred embodiment for lower connection **226** (and **228**). In this preferred embodiment, side tube **216** (or **218**) is preferably set at an acute angle A relative to leg portion **202**, including leg base section **250**. In other words, the following features are aligned on an axis B: side tube **216** (or **218**), slots **288**, slots **270**, pin **290**, walls **242** and **244**. The following features are aligned on an axis C: female receptor **246**, base leg section **250**, and counter attachments **404** and **420** (excluding the counters **414** and **440**). Axis B is preferably set at acute angle A relative to axis C. Body **240** is molded and its inner steel bracket is fabricated such that its features on axis A, including the opening for pin **290** and slots **270**, is set at acute angle A relative to female receptor or sleeve **246**.

Such an acute angle A works to minimize any gap between the first side **26** of mattress **16** and the rail portion **204** for a number of reasons. First, because of the acute angle, the rail portion **204** lies closer to the upper side of mattress **16** than the lower side of the mattress **16**. The rail portion **204** is needed at the upper side to prevent a person from rolling off of the bed **24**. Second, except for perhaps high tech excessively expensive mechanical arrangements such as found at NASA, mechanical arrangements may loosen over time. The provision of features providing for angle A minimizes the chance that the angle A would become obtuse, i.e., greater than ninety degrees, whereby the rail portion **204** would extend upwardly and away from the first side **26** of mattress **16**. Third, angle A works in combination with counter attachments **404** and **420** where the sections of the counter attachments are readily slideable relative to each other to decrease the effective length of the legs of leg portion **204**. In other words, as to this third point, mattress **16** may be hugged more tightly between counters **414** (or **440**) and the rail portion **204** because acute angle A permits the rail portion **204** to give somewhat. Rail portion **204** gives somewhat because of the mechanical arrangement of the rail portion **204** as a whole, because of the mechanical

connection between rail portion **204** and the lower connections **226**, **228**, because of the mechanical hinge arrangement **220** and because of the mechanical frame assembly **206**. In light of the above three factors, the chances that rail portion **204** closely confronts the upper face of the mattress **16** at first side **26** of mattress **16** are maximized.

FIG. **19** shows rail portion **204** swung downwardly relative to the leg portion **202**. When the bed rail **200** is not in use, such as during daytime hours, the rail portion **204** is swung downwardly by disengaging rollers **272** from slots **270** on the lower connections **226**, **228** and pivoting the rail portion **204** as a whole against the first side **26** of the box spring **18**. When swung downwardly, side rails **216**, **218** confront stops **460** (shown in FIG. **15A** and FIG. **19**) of sleeve or receptor **246**. To place the rail portion **204** into the upright operating position, rail portion **204** is swung upwardly such that rollers **272** roll against peripheral surface **294** and such that rollers **272** then snap into detents **270** under pressure from the coil springs **282** whereupon the rail portion **204** is locked relative to the leg portion **202**.

FIG. **19** shows that tubes **216**, **218** can be swung from the downward position shown in FIG. **19**, to the upright operating position shown by first arrowhead **462**, to the folded position shown by second arrowhead **464** such that tubes **216**, **218** can be swung through about a 270 degree arc relative to leg portion **204**.

FIGS. **20A**, **20B** and **20C** show the preferred embodiment for button **402** (and for button **436**). Button **402** includes the tapering face **158** and the vertical face **160**. Button **402** further includes a second vertical face **470** opposite of vertical face **160** and running generally parallel thereto. Button **402** is a spring that during manufacture is slid into base leg section **250** and does not need to be affixed to base leg section **250**. More specifically, button **402** includes a spring **472** having a base arm **474** and an upper arm **476**. Upper arm **476** includes a head **478**. Head **478** includes the vertical surfaces **160**, **470** and the tapering surface **158**. Head **478** further includes an upper surface **480** with which a finger may make contact to depress the head **478**. From a top view, head **478** is round, as shown in FIG. **9**.

Vertical surface **160** of head **478** can extend through opening **480** in base leg section **250** and can further extend through opening **412** in section **406**. Vertical surface **470** of head **478** can extend through opening **480** in base leg section **250** and cannot extend through opening **412** in section **406**. Tapering surface **158** of head **478** cannot extend through opening **480** in base leg section **250** when the spring **472** is fully extended (not depressed) and can extend through opening **412** in section **406** when the spring **472** is fully extended (not depressed). In other words, when the spring **472** is fully extended, the intersection or juncture of tapering surface **158** and vertical surface **470** is disposed about at the juncture of the upper outer surface of base leg section **250** and the lower inner surface of section **406**.

FIG. **20B** shows that when one attempts to increase the length of leg portion **202**, a portion of section **406** forming slot **412** brings pressure to bear upon vertical surface **160** of head **478**, which in turn may slide the button **402** toward the opposite edge of opening **480** until vertical surface **470** of head **478** abuts such opposite edge of opening **480** formed in base leg section **250**, which prevents further sliding of the section **406** relative to base leg **250** in the direction of sliding that was attempted. Such further sliding is permitted only by depressing button **402** by an outside object such as a finger, wherein button **402** is depressed into base leg section **250**.

FIG. **20C** shows that sliding in the other direction (the direction opposite to that shown in FIG. **20B**) is permitted,

without a finger depressing the button **402**. Here, upon sliding in such opposite direction, a portion of section **406** forming slot **412** brings pressure to bear upon tapering surface **158**, which automatically depresses the head **478** into base leg section **250** and permits such sliding to continue. Accordingly, length of leg portion **402** is decreased with a minimal amount of effort.

As noted above, button **436** includes the same structure as button **402**. Hence, button **436** includes the second vertical surface **470** opposite of vertical surface **160**. However, whereas tapering surface **158** of button **402** faces the direction of counters **414** and **440**, tapering surface **158** of button **436** faces the direction of the rail portion **204**. Thus, with counter attachment **420**, decreasing the length of a leg of leg portion **202** is relatively easy, because section **422** encounters the tapering side **158** of button **402** when being pushed onto base leg section **250** and because the tapering surface **158** of button **436** encounters the slot edges of slots **432** when section **424** is being pushed onto section **422**. Conversely, increasing the length of counter attachment **420** is relatively difficult because the vertical surfaces **160** and **470** are encountered.

In operation, the bed rail **200** is removed from the factory provided box or bag with the fabric wall **370** already engaged to the frame assembly **206**. Then tubes **212**, **214** may be engaged to each other and further engaged in their respective cradles **254** to hold the lower end portions of side tubes **216**, **218** in a spaced apart rigid relationship via the absolute ends of the tubes **212**, **214** confronting and abutting the lower connections **226**, **228**. Then base leg sections **250** may be swung such that rollers **272** engage detents **270** and such that base leg sections **250** are set at an acute angle relative to rail portion **204**. Base leg sections **250** may then be tucked into the first side **26** of the bed **24** between the mattress **16** and the box spring **18**. Then either of the counter attachments **404**, **420** is engaged to the base leg sections **250** by sliding the counter attachment into the second side **28** of the bed **24** between the mattress **16** and the box spring **18** until the counter attachments **404** (or **420**) meets with and is engaged to base leg section **250**. (If counter attachment **420** is used, medial section **422** may be first attached to the base leg section **250** or may be first attached to counter section **424**). Here, it should be noted that, since slots **412**, **432** are provided on only one side of the counter attachments **404**, **420**, the counter **414** (or **440**) can not be locked into the downward position, such as against box spring **18**. Then, with the mattress **16** between the upright and locked rail portion **204** and the counter **414** (or **440**), the counter **414** and rail portion **204** are pushed relatively toward each other until the mattress **16** is tightly hugged and until the rail portion **204** abuts the upper surface of the mattress **16** at the first side **26** of the mattress **16** such that no gap exists therebetween and a person may safely sleep upon the mattress **16**. During daytime hours, the rail portion **204** may be swung down to the out-of-the-way position shown in FIG. **19**, and then swung upwardly at bedtime to the upright operating and locked position shown in FIG. **18**. To make the effective length of the leg portion **202** greater, a relative great amount of effort is required. Mattress **16** must be taken off of the leg portion **204** or access must otherwise be gained to buttons **402** (or **402** and **436**) and then buttons **402** (or **436**) must be repeatedly depressed as section **406** (or **424**) is drawn out of its cooperating leg section and drawn away from rail portion **204**. To fold the bed rail **200**, lower tubes **212**, **214** are removed from their cradles **254** and the counter attachments **404** (or **420**) are removed from their base leg sections **250**. Rollers **272** are unlocked from their detents

270 and base leg sections **250** are swung up to be parallel to side tubes **216**, **218**. Then hinge mechanism **220** is unlocked by unlocking mechanism **342** such that upper tubes **208**, **210** may be swung to confront and be parallel with side tubes **216**, **218** and the pair of base leg sections **250**, as shown in FIG. **13**, whereby six tubes are generally parallel with each other.

Thus since the invention disclosed herein may be embodied in other specific forms without departing from the spirit or general characteristics thereof, some of which forms have been indicated, the embodiments described herein are to be considered in all respects illustrative and not restrictive. The scope of the invention is to be indicated by the appended claims, rather than by the foregoing description, and all changes which come within the meaning and range of equivalents of the claims are intended to be embraced therein.

We claim:

1. A bed rail adapted for engagement to a bed having a first side, a second side, and a sleeping surface, wherein the bed rail comprises:

- a) a leg portion comprising a tubular portion;
- b) a rail portion engaged to the leg portion and confronting the first side of the bed;
- c) wherein the rail portion extends from the leg portion to and beyond the sleeping surface to prevent a person on the sleeping surface from rolling off the bed;
- d) wherein the leg portion extends from the rail portion toward the second side of the bed;
- e) a counter member engaged to the leg portion and adapted for engaging the second side of the bed to keep the rail portion hugging the first side of the bed; f) a flexible member comprising a strap, wherein the strap is engaged between one of i) the leg portion and counter member and ii) the rail portion and counter member to keep the rail portion hugging the first side of the bed; and
- g) wherein the rail portion and the leg portion can be relatively swingable to each other and away from each other.

2. The bed rail according to claim 1, wherein the first and second sides of the bed are opposite one another, and wherein the rail portion and counter member hug the bed therebetween.

3. The bed rail according to claim 1, wherein the strap is engaged between the leg portion and counter member.

4. The bed rail according to claim 1, wherein the strap is engaged between the rail portion and counter member to keep the rail portion hugging the first side of the bed.

5. The bed rail according to claim 1, wherein the rail portion includes a frame, wherein the frame includes a wall, and wherein the wall includes a rigid component.

6. The bed rail according to claim 1, wherein the rail portion includes a frame, wherein the frame includes a wall, and wherein the wall includes several rigid components.

7. The bed rail according to claim 1, wherein the rail portion includes a frame, wherein the frame includes a wall, and wherein the wall is rigid along a plane of the sleeping surface.

8. A bed rail adapted for engagement to a bed having a first side, a second side, and a sleeping surface, with the first and second sides of the bed being opposite one another, wherein the bed rail comprises;

- a) a pair of leg portions;
- b) a rail portion engaged to each of the leg portions and confronting the first side of the bed;

19

- c) wherein the rail portion extends from the leg portions to and beyond the sleeping surface to prevent a person on the sleeping surface from rolling off the bed;
- d) wherein each of the leg portions extends from the rail portion toward the second side of the bed; 5
- e) a counter member engaged to the leg portions and adapted for engaging the second side of the bed to keep the rail portion hugging the first side of the bed, with the rail portion and counter member hugging the bed therebetween; 10
- f) a pair of flexible portions, wherein one of the flexible portions is engaged between said counter member and one of the leg portions and wherein the other of the flexible portions is engaged between said counter member and the other of the leg portions to keep the rail portion hugging the first side of the bed; 15
- g) wherein said counter member is relatively drawably to and away from said leg portions via said flexible portions; and
- h) wherein each of the flexible portions extends at an acute angle relative to the leg portion from which said flexible portion extends. 20
- 9.** A bed rail adapted for engagement to a bed having a first side, a second side, and a sleeping surface, with the first and second sides of the bed being opposite one another, wherein the bed rail comprises: 25
- a) a pair of leg portions;
- b) a rail portion engaged to each of the leg portions and confronting the first side of the bed;
- c) wherein the rail portion extends from the leg portions to and beyond the sleeping surface to prevent a person on the sleeping surface from rolling off the bed; 30
- d) wherein each of the leg portions extends from the rail portion toward the second side of the bed;
- e) a pair of counter members engaged to the leg portions and adapted for engaging the second side of the bed to keep the rail portion hugging the first side of the bed, with the rail portion and counter members hugging the bed therebetween; 35
- f) a pair of flexible portions, wherein one of the flexible portions is engaged between one of the counter members and one of the leg portions and wherein the other of the flexible portions is engaged between the other of the counter members and the other of the leg portions to keep the rail portion hugging the first side of the bed; and 40
- g) wherein the counter members are relatively drawably to and away from said leg portions via said flexible portions.
- 10.** A bed rail adapted for engagement to a bed having a first side, a second side, and a sleeping surface, with the first and second sides of the bed being opposite one another, wherein the bed rail comprises: 50
- a) a pair of flexible portions;
- b) a rail portion engaged to each of the flexible portions and confronting the first side of the bed, with the rail portion lying in a plane, with the rail portion comprising an upper rail, a lower rail, and side rails, with the upper rail being engaged to the side rails via corner connections, and with the lower rail being engaged to the side rails via corner connections; 60
- c) wherein the rail portion extends from the flexible portions to and beyond the sleeping surface to prevent a person on the sleeping surface from rolling off the bed;
- d) wherein each of the flexible portions extends from the rail portion toward the second side of the bed; 65

20

- e) a pair of counter members engaged to the flexible portions and adapted for engaging the second side of the bed to keep the rail portion hugging the first side of the bed, with the rail portion and counter members hugging the bed therebetween;
- f) wherein one of the flexible portions is engaged between one of the counter members and the rail portion and wherein the other of the flexible portions is engaged between the other of the counter members and the rail portion to keep the rail portion hugging the first side of the bed; and
- g) wherein the counter members are relatively drawably to and away from the rail portion via said flexible portions.
- 11.** A bed rail adapted for engagement to a bed having a first side, a second side, and a sleeping surface, with the first and second sides of the bed being opposite one another, wherein the bed rail comprises:
- a) a pair of flexible portions;
- b) a rail portion engaged to each of the flexible portions and confronting the first side of the bed, with the rail portion lying in a plane, with the rail portion comprising an upper rail, a lower rail, and side rails, with the upper rail being engaged to the side rails via corner connections, and with the lower rail being engaged to the side rails via corner connections;
- c) wherein the rail portion extends from the flexible portions to and beyond the sleeping surface to prevent a person on the sleeping surface from rolling off the bed;
- d) wherein each of the flexible portions extends from the rail portion toward the second side of the bed;
- e) a counter member engaged to each of the flexible portions and adapted for engaging the second side of the bed to keep the rail portion hugging the first side of the bed, with the rail portion and counter member hugging the bed therebetween;
- f) wherein one of the flexible portions is engaged between said counter member and the rail portion and wherein the other of the flexible portions is engaged between said counter member and the rail portion to keep the rail portion hugging the first side of the bed;
- g) wherein said counter member is relatively drawably to and away from the rail portion via said flexible portions; and
- h) wherein each of the flexible portions extends at an acute angle relative to the rail portion.
- 12.** A bed rail adapted for engagement to a bed having a first side, a second side, and a sleeping surface, with the bed further having a mattress and box spring, wherein the bed rail comprises:
- a) a leg portion comprising a tubular portion;
- b) a rail portion engaged to the leg portion and confronting the first side of the bed;
- c) wherein the rail portion extends from the leg portion to and beyond the sleeping surface to prevent a person on the sleeping surface from rolling off the bed;
- d) wherein the leg portion extends from the rail portion toward the second side of the bed;
- e) a counter member engaged to the leg portion and adapted for engaging the second side of the bed to keep the rail portion hugging the first side of the bed;
- f) a flexible member comprising a strap, wherein the strap is engaged between one of i) the leg portion and counter member and ii) the rail portion and counter member to keep the rail portion hugging the first side of the bed;

21

- g) wherein the counter member comprises an upper portion for engaging the mattress and a lower portion for engaging the box spring; and
 - h) wherein the rail portion and the leg portion can be relatively swingable to each other and away from each other.
13. The bed rail according to claim 12, wherein the counter member further comprises a pair of apertures for receiving the strap.

22

14. The bed rail according to claim 12, wherein the counter member further lies generally in a plane.
15. The bed rail according to claim 12, wherein the strap engages the counter member in a looped fashion.
16. The bed rail according to claim 12, wherein the strap engages the counter member in a looped fashion and wherein portions of the strap lay on top of each other.

* * * * *

UNITED STATES PATENT AND TRADEMARK OFFICE
CERTIFICATE OF CORRECTION

PATENT NO. : 7,178,184 B2
APPLICATION NO. : 11/243899
DATED : February 20, 2007
INVENTOR(S) : Mark A. Flannery and Nathan A. Dusheck

Page 1 of 1

It is certified that error appears in the above-identified patent and that said Letters Patent is hereby corrected as shown below:

Column 8, line 47

“ho” should be --no--.

Column 9, line 49

“AS” should be --As--.

Column 17, line 18

“button. 436” should be --button 436--.

Column 18, Claim 1

In line 32, a new paragraph should start between “bed;” and “f”).

Column 22, Claim 16

In line 6, “an” should be --in--.

Signed and Sealed this

Fourteenth Day of April, 2009

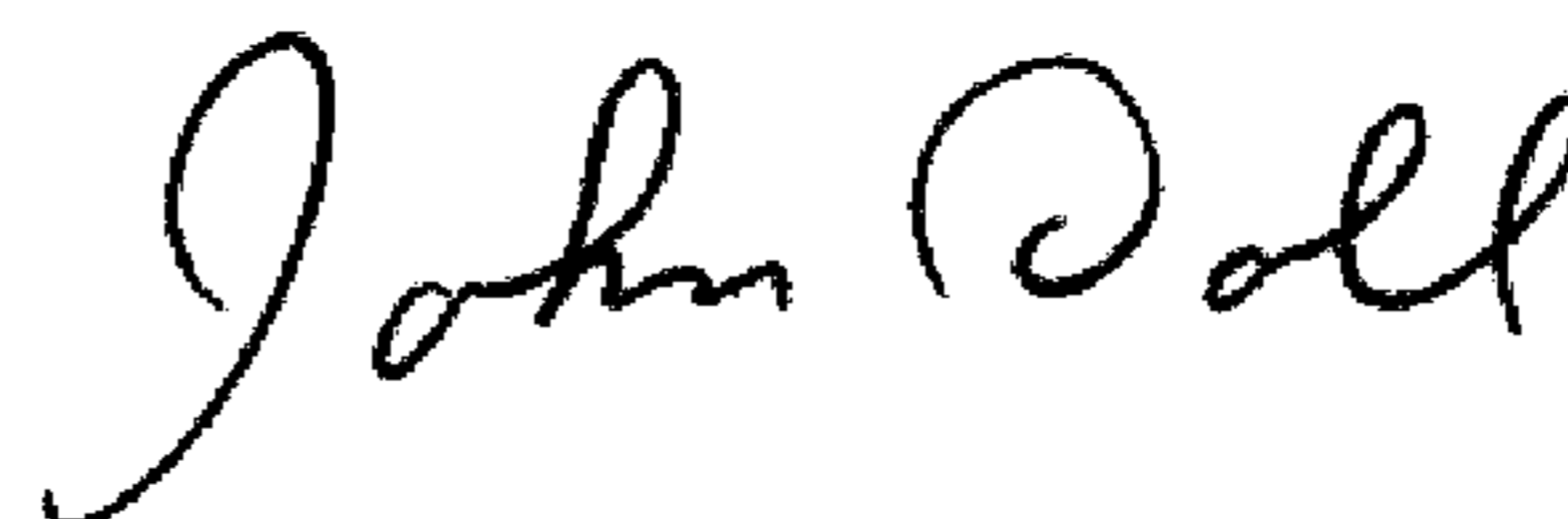

JOHN DOLL

Acting Director of the United States Patent and Trademark Office



US007178184C1

(12) **EX PARTE REEXAMINATION CERTIFICATE** (9247th)
United States Patent
Flannery et al.

(10) **Number:** **US 7,178,184 C1**
(45) **Certificate Issued:** ***Aug. 28, 2012**

(54) **MATTRESS HUGGING BED RAIL**

(75) Inventors: **Mark A. Flannery**, Shorewood, MN (US); **Nathan A Dusheck**, Hammond, WI (US)

(73) Assignee: **Regalo International, LLC**, Prior Lake, MN (US)

Reexamination Request:

No. 90/009,498, Jun. 19, 2009

Reexamination Certificate for:

Patent No.: **7,178,184**
Issued: **Feb. 20, 2007**
Appl. No.: **11/243,899**
Filed: **Oct. 4, 2005**

(*) Notice: This patent is subject to a terminal disclaimer.

Certificate of Correction issued Apr. 14, 2009.

Related U.S. Application Data

(63) Continuation of application No. 10/652,296, filed on Aug. 29, 2003, now Pat. No. 6,952,846.

(60) Provisional application No. 60/407,369, filed on Aug. 30, 2002.

(51) **Int. Cl.**
A47C 21/08 (2006.01)

(52) **U.S. Cl.** **5/425; 5/426; 5/430; 5/662**

(58) **Field of Classification Search** 5/425, 5/426, 430, 658, 659, 662, 663
See application file for complete search history.

(56) **References Cited**

To view the complete listing of prior art documents cited during the proceeding for Reexamination Control Number 90/009,498, please refer to the USPTO's public Patent Application Information Retrieval (PAIR) system under the Display References tab.

Primary Examiner—Jimmy T Nguyen

(57) **ABSTRACT**

A bed rail structured to minimize the gap between the mattress and the bed rail and including a leg portion and a rail portion. The rail portion extends upwardly on a first side of the mattress to extend beyond the sleeping surface of the mattress and prevent a person from rolling out of bed. The leg portion is sandwiched between the mattress and the box spring and extends toward a second side of the mattress. In one embodiment, the leg portion includes a distal end that is engaged to the second side of at least one of the mattress and box spring such that the distal end and rail portion hug the mattress. In another embodiment, the bed rail includes a relatively rigid cover depending from an upper portion of the rail portion to the sleeping surface so as to cover a gap that may exist between the first side of the mattress and the rail portion. In still another embodiment, the rail portion is set at an acute angle relative to the leg portion so as to tend to close off any gap between the first side of the mattress and the rail portion.

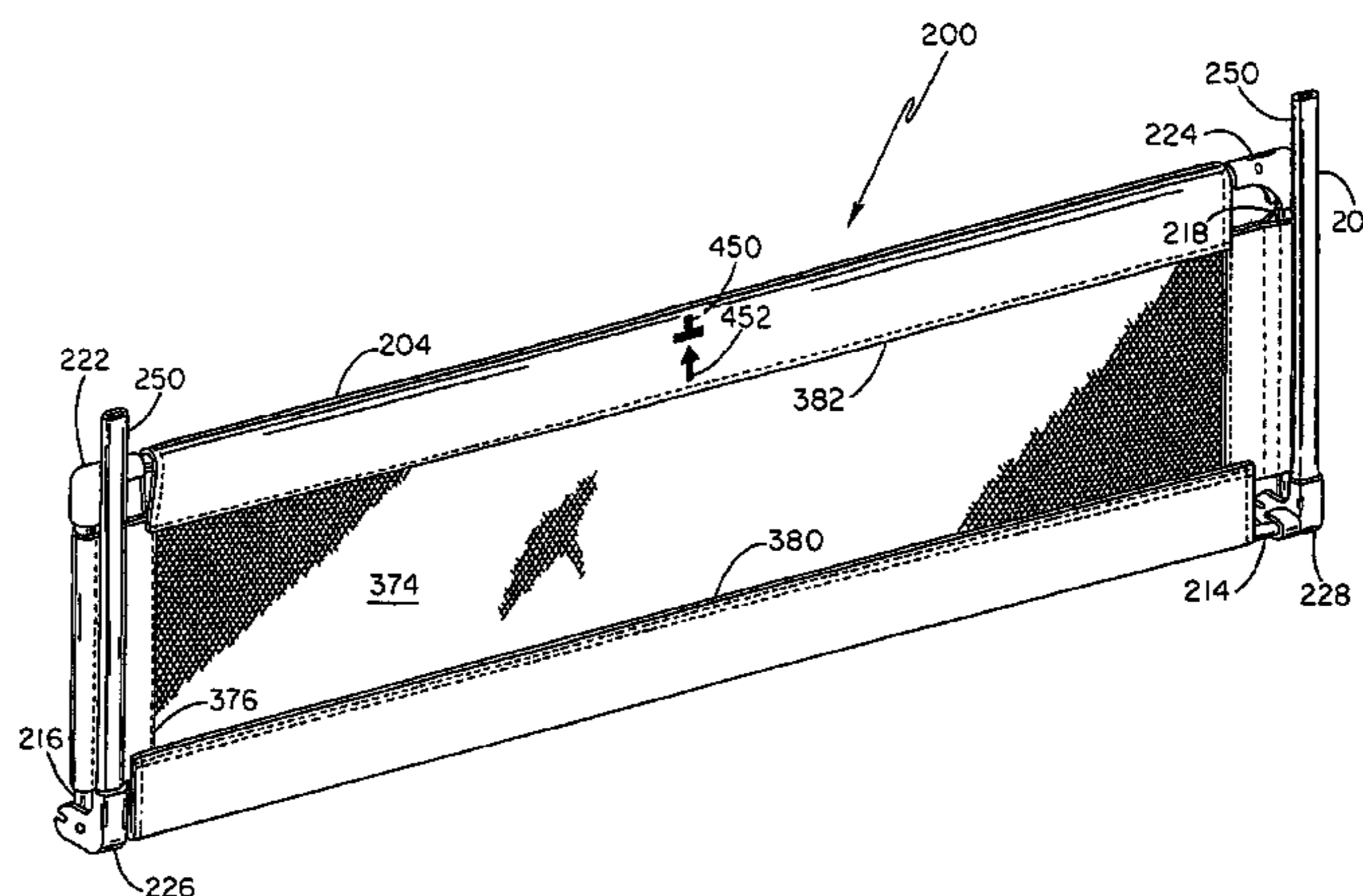
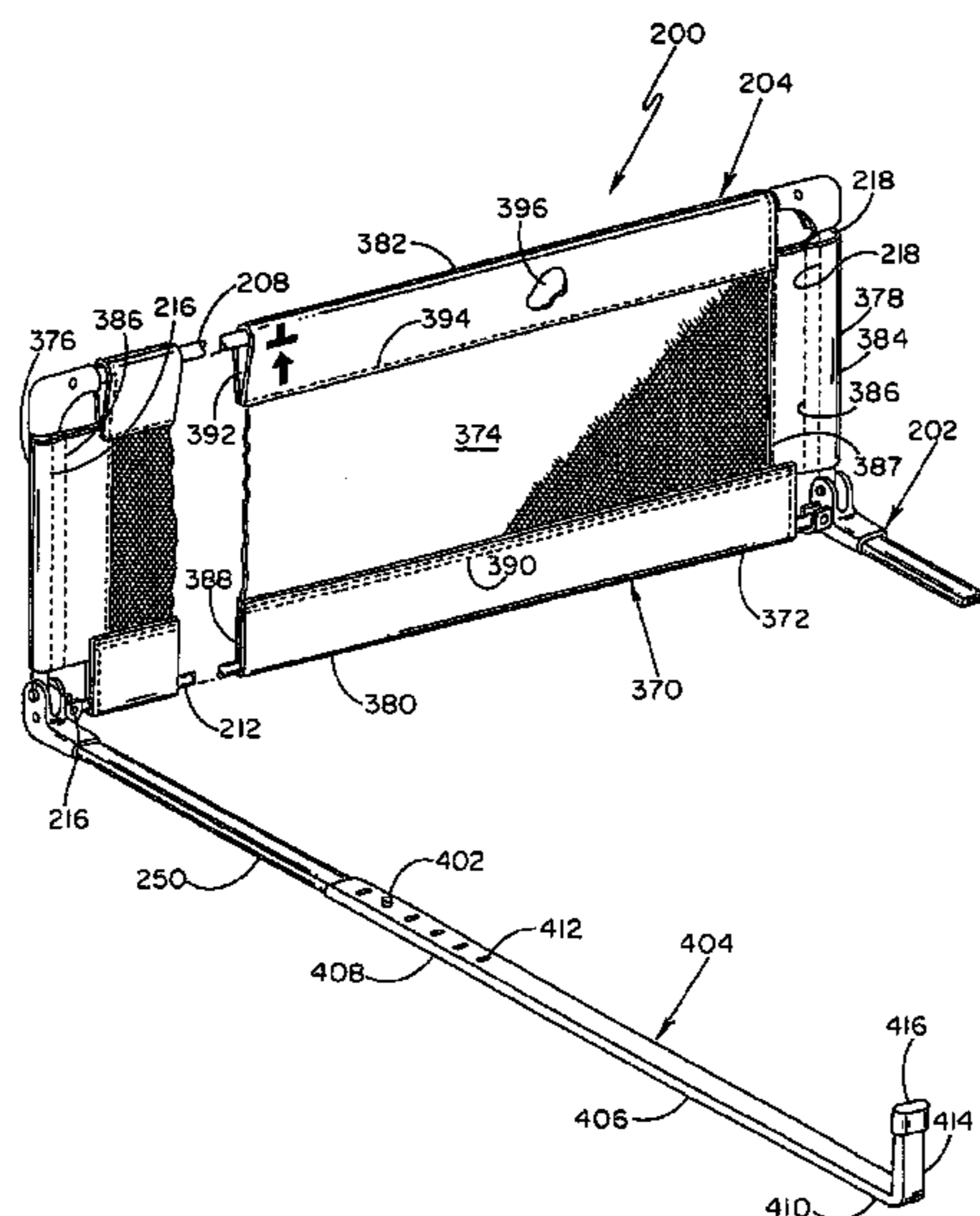

1
EX PARTE
REEXAMINATION CERTIFICATE
ISSUED UNDER 35 U.S.C. 307

THE PATENT IS HEREBY AMENDED AS
INDICATED BELOW.

Matter enclosed in heavy brackets [] appeared in the patent, but has been deleted and is no longer a part of the patent; matter printed in italics indicates additions made to the patent.

AS A RESULT OF REEXAMINATION, IT HAS BEEN DETERMINED THAT:

Claims 1-3, 5, 7, 8 and 12 are cancelled.

New claims 17-27 are added and determined to be patentable.

17. A bed rail adapted for engagement to a bed having a first side, a second side, and a sleeping surface, wherein the bed rail comprises:

- a) *a leg portion comprising a tubular portion;*
- b) *a rail portion engaged to the leg portion and confronting the first side of the bed;*
- c) *wherein the rail portion extends from the leg portion to and beyond the sleeping surface to prevent a person on the sleeping surface from rolling off the bed;*
- d) *wherein the leg portion extends from the rail portion toward the second side of the bed;*
- e) *a counter member engaged to the leg portion and adapted for engaging the second side of the bed to keep the rail portion hugging the first side of the bed to minimize a creation of a gap between the rail portion and the first side of the bed;*
- f) *a flexible member comprising a strap, wherein the strap is engaged between one of i) the leg portion and counter member and ii) the rail portion and counter member to keep the rail portion hugging the first side of the bed, and wherein said strap is adjustable in length such that the rail portion and counter member can be drawn toward each other;*
- g) *wherein the rail portion and the leg portion can be relatively swingable to each other and away from each other;*
- h) *wherein the rail portion includes:*
 - i) *a frame, with the frame comprising an upper tube, a lower tube and a pair of side tubes; and*
 - ii) *a wall, with the wall engaged to the frame, and with the wall including sheeting and tubing; and*
- i) *wherein the wall comprises:*
 - i) *a sidewall sheet section having a tubular portion through which said side tube runs;*
 - ii) *a lower wall sheet section having a tubular portion through which said lower tube runs;*
 - iii) *an upper wall sheet section having a tubular portion through which said upper tube runs;*
 - iv) *with each of the sidewall sheet section, lower wall sheet section and upper wall sheet section being engaged to an adjacent sheet section with stitching; and*
 - v) *with each of the sidewall sheet section, lower wall sheet section and upper wall sheet section engaging mesh, with said mesh being on an interior of said wall.*

2

18. A bed rail adapted for engagement to a bed having a first side, a second side, and a sleeping surface, wherein the bed rail comprises:

- a) *a leg portion comprising a tubular portion;*
 - b) *a rail portion engaged to the leg portion and confronting the first side of the bed;*
 - c) *wherein the rail portion extends from the leg portion to and beyond the sleeping surface to prevent a person on the sleeping surface from rolling off the bed;*
 - d) *wherein the leg portion extends from the rail portion toward the second side of the bed;*
 - e) *a counter member engaged to the leg portion and adapted for engaging the second side of the bed to keep the rail portion hugging the first side of the bed to minimize a creation of a gap between the rail portion and the first side of the bed;*
 - f) *a flexible member comprising a strap, wherein the strap is engaged between one of i) the leg portion and counter member and ii) the rail portion and counter member to keep the rail portion hugging the first side of the bed, and wherein said strap is adjustable in length such that the rail portion and counter member can be drawn toward each other;*
 - g) *wherein the rail portion and the leg portion can be relatively swingable to each other and away from each other;*
 - h) *wherein the rail portion includes:*
 - i) *a frame, with the frame comprising an upper tube, a lower tube and a pair of side tubes; and*
 - ii) *a wall, with the wall engaged to the frame, and with the wall including sheeting and tubing; and*
 - i) *wherein:*
 - i) *said counter member includes an upper portion for confronting a mattress of said second side of said bed, a lower portion for confronting a box spring of said second side of said bed, and a pair of apertures;*
 - ii) *said leg portion includes a piece riveted to said leg portion, and with said piece including a slot; and*
 - iii) *said strap engages in a looped fashion said pair of apertures of said counter member and wherein said strap engages said slot of said piece.*
- 19. A bed rail adapted for engagement to a bed having a first side, a second side, and a sleeping surface, with the first and second sides of the bed being opposite one another, wherein the bed rail comprises:*
- a) *a pair of leg portions, with said leg portion comprising a tubular portion;*
 - b) *a rail portion engaged to each of the leg portions and confronting the first side of the bed;*
 - c) *wherein the rail portion extends from the leg portions to and beyond the sleeping surface to prevent a person on the sleeping surface from rolling off the bed;*
 - d) *wherein each of the leg portions extends from the rail portion toward the second side of the bed;*
 - e) *a counter member engaged to the leg portions and adapted for engaging the second side of the bed to keep the rail portion hugging the first side of the bed to minimize the creation of a gap between the rail portion and the first side of the bed, with the rail portion and counter member hugging the bed therebetween;*
 - f) *a pair of flexible portions, wherein one of the flexible portions is engaged between said counter member and one of the leg portions and wherein the other of the flexible portions is engaged between said counter mem-*

3

- ber and the other of the leg portions to keep the rail portion hugging the first side of the bed, and with said flexible portion comprising a strap;*
- g) *wherein said counter member is relatively drawable to and away from said leg portions via said flexible portions;*
- h) *wherein each of the flexible portions extends at an acute angle relative to the leg portion from which said flexible portion extends;*
- i) *wherein the rail portion includes:*
- i) *a frame, with the frame comprising an upper tube, a lower tube and a pair of side tubes; and*
- ii) *a wall, with the wall engaged to the frame, and with the wall including sheeting and a rigid component;*
- j) *wherein the rail portion and the leg portion can be relatively swingable to each other and away from each other; and*
- k) *wherein the wall comprises:*
- i) *a sidewall sheet section having a tubular portion through which said side tube runs;*
- ii) *a lower wall sheet section having a tubular portion through which said lower tube runs;*
- iii) *an upper wall sheet section having a tubular portion through which said upper tube runs;*
- iv) *with each of the sidewall sheet section, lower wall sheet section and upper wall sheet section being engaged to an adjacent sheet section with stitching; and*
- v) *with each of the sidewall sheet section, lower wall sheet section and upper wall sheet section engaging mesh, with said mesh being on an interior of said wall.*
20. *A bed rail adapted for engagement to a bed having a first side, a second side, and a sleeping surface, with the first and second sides of the bed being opposite one another, wherein the bed rail comprises:*
- a) *a pair of leg portions, with said leg portion comprising a tubular portion;*
- b) *a rail portion engaged to each of the leg portions and confronting the first side of the bed;*
- c) *wherein the rail portion extends from the leg portions to and beyond the sleeping surface to prevent a person on the sleeping surface from rolling off the bed;*
- d) *wherein each of the leg portions extends from the rail portion toward the second side of the bed;*
- e) *a counter member engaged to the leg portions and adapted for engaging the second side of the bed to keep the rail portion hugging the first side of the bed to minimize the creation of a gap between the rail portion and the first side of the bed, with the rail portion and counter member hugging the bed therebetween;*
- f) *a pair of flexible portions, wherein one of the flexible portions is engaged between said counter member and one of the leg portions and wherein the other of the flexible portions is engaged between said counter member and the other of the leg portions to keep the rail portion hugging the first side of the bed, and with said flexible portion comprising a strap;*
- g) *wherein said counter member is relatively drawable to and away from said leg portions via said flexible portions;*
- h) *wherein each of the flexible portions extends at an acute angle relative to the leg portion from which said flexible portion extends;*

4

- i) *wherein the rail portion includes:*
- i) *a frame, with the frame comprising an upper tube, a lower tube and a pair of side tubes; and*
- ii) *a wall, with the wall engaged to the frame, and with the wall including sheeting and a rigid component;*
- j) *wherein the rail portion and the leg portion can be relatively swingable to each other and away from each other; and*
- k) *wherein:*
- i) *said counter member include an upper portion for confronting a mattress of said second side of said bed, a lower portion for confronting a box spring of said second side of said bed, and a pair of apertures;*
- ii) *said leg portion includes a piece riveted to said leg portion, and with said piece including a slot; and*
- iii) *said strap engages in a looped fashion said pair of apertures of said counter member and wherein said strap engages said slot of said piece.*
21. *A bed rail adapted for engagement to a bed having a first side, a second side, and a sleeping surface, with the bed further having a mattress and box spring, wherein the bed rail comprises:*
- a) *a leg portion comprising a tubular portion;*
- b) *a rail portion engaged to the leg portion and confronting the first side of the bed;*
- c) *wherein the rail portion extends from the leg portion to and beyond the sleeping surface to prevent a person on the sleeping surface from rolling off the bed;*
- d) *wherein the leg portion extends from the rail portion toward the second side of the bed;*
- e) *a counter member engaged to the leg portion and adapted for engaging the second side of the bed to keep the rail portion hugging the first side of the bed to minimize a creation of a gap between the rail portion and the first side of the bed;*
- f) *a flexible member comprising a strap, wherein the strap is engaged between one of i) the leg portion and counter member and ii) the rail portion and counter member to keep the rail portion hugging the first side of the bed, and wherein said strap is adjustable in length such that the rail portion and counter member can be drawn toward each other;*
- g) *wherein the counter member comprises an upper portion for engaging the mattress and a lower portion for engaging the box spring;*
- h) *wherein the rail portion and the leg portion can be relatively swingable to each other and away from each other;*
- i) *wherein the rail portion includes:*
- i) *a frame, with the frame comprising an upper tube, a lower tube and a pair of side tubes; and*
- ii) *a wall, with the wall engaged to the frame, and with the wall being rigid along the plane of the sleeping surface; and*
- j) *wherein the wall comprises:*
- i) *a sidewall sheet section having a tubular portion through which said side tube runs;*
- ii) *a lower wall sheet section having a tubular portion through which said lower tube runs;*
- iii) *an upper wall sheet section having a tubular portion through which said upper tube runs;*
- iv) *with each of the sidewall sheet section, lower wall sheet section and upper wall sheet section being engaged to an adjacent sheet section with stitching; and*

5

v) with each of the sidewall sheet section, lower wall sheet section and upper wall sheet section engaging mesh, with said mesh being on an interior of said wall.

22. The bed rail according to claim 1, wherein the rail portion includes a frame, wherein the frame includes an upper tube, a lower tube and a pair of side tubes, and wherein the wall comprises:

- a) a sidewall sheet section having a tubular portion through which said side tube runs;
- b) a lower wall sheet section having a tubular portion through which said lower tube runs;
- c) an upper wall sheet section having a tubular portion through which said upper tube runs;
- d) with each of the sidewall sheet section, lower wall sheet section and upper wall sheet section being engaged to an adjacent sheet section with stitching; and
- e) with each of the sidewall sheet section, lower wall sheet section and upper wall sheet section engaging mesh, with said mesh being on an interior of said wall.

23. The bed rail according to claim 1, wherein:

- a) said counter member includes an upper portion for confronting a mattress of said second side of said bed, a lower portion for confronting a box spring of said second side of said bed, and a pair of apertures;
- b) said leg portion includes a piece riveted to said leg portion, and with said piece including a slot; and
- c) said strap engages in a looped fashion said pair of apertures of said counter member and wherein said strap engages said slot of said piece.

24. The bed rail according to claim 8, wherein the rail portion includes a frame, wherein the frame includes an upper tube, a lower tube and a pair of side tubes, and wherein the wall comprises:

- a) a sidewall sheet section having a tubular portion through which said side tube runs;
- b) a lower wall sheet section having a tubular portion through which said lower tube runs;
- c) an upper wall sheet section having a tubular portion through which said upper tube runs;
- d) with each of the sidewall sheet section, lower wall sheet section and upper wall sheet section being engaged to an adjacent sheet section with stitching; and
- e) with each of the sidewall sheet section, lower wall sheet section and upper wall sheet section engaging mesh, with said mesh being on an interior of said wall.

25. The bed rail according to claim 8, wherein:

- a) said counter member includes an upper portion for confronting a mattress of said second side of said bed, a lower portion for confronting a box spring of said second side of said bed, and a pair of apertures;
- b) said leg portion includes a piece riveted to said leg portion, and with said piece including a slot; and
- c) said strap engages in a looped fashion said pair of apertures of said counter member and wherein said strap engages said slot of said piece.

26. The bed rail according to claim 12, wherein the rail portion includes a frame, wherein the frame includes an upper tube, a lower tube and a pair of side tubes, and wherein the wall comprises:

- a) a sidewall sheet section having a tubular portion through which said side tube runs;
- b) a lower wall sheet section having a tubular portion through which said lower tube runs;

6

c) an upper wall sheet section having a tubular portion through which said upper tube runs;

d) with each of the sidewall sheet section, lower wall sheet section and upper wall sheet section being engaged to an adjacent sheet section with stitching; and

e) with each of the sidewall sheet section, lower wall sheet section and upper wall sheet section engaging mesh, with said mesh being on an interior of said wall.

27. A bed rail adapted for engagement to a bed having a first side, a second side, and a sleeping surface, wherein the bed rail comprises:

- a) a leg portion comprising a tubular portion;
- b) a rail portion engaged to the leg portion and confronting the first side of the bed;
- c) wherein the rail portion extends from the leg portion to and beyond the sleeping surface to prevent a person on the sleeping surface from rolling off the bed;
- d) wherein the leg portion extends from the rail portion toward the second side of the bed;
- e) a counter member engaged to the leg portion and adapted for engaging the second side of the bed to keep the rail portion hugging the first side of the bed;
- f) a flexible member comprising a strap, wherein the strap is engaged between one of i) the leg portion and counter member and ii) the rail portion and counter member to keep the rail portion hugging the first side of the bed;
- g) wherein the rail portion and the leg portion can be relatively swingable to each other and away from each other;
- h) a molded body on said leg portion;
- i) wherein said molded body includes a pair of spaced apart sidewalls, with a side tube of said rail portion being between said spaced apart sidewalls;
- j) wherein said spaced apart sidewall includes an upper slot;
- k) wherein said side tube includes a spring biased plunger traveling in the axial direction of said side tube, with said spring biased plunger including a portion for engaging said upper slot such that said rail portion is locked to the leg portion when said portion of said spring biased plunger is in said upper slot and such that said rail portion is unlocked to said leg portion when said portion of said spring biased plunger is out of said upper slot;
- l) wherein said spaced apart sidewall includes a partially curved perimeter;
- m) wherein said portion of said spring biased plunger rides on said partially curved perimeter when the rail portion and leg portion are relatively swung to each other and away from each other;
- n) wherein the rail portion includes a frame, wherein the frame includes an upper tube, a lower tube and a pair of side tubes, wherein the lower tube of the frame includes a pair of lower tube portions that engage each other with a male/female connection, with each of the lower tube portions having an inner end portion, with one of the inner end portions having a button that is biased outwardly, with the other of the inner end portions having a hole that receives said button, and with said button snapping into said hole to lock said pair of lower tube portions to each other;
- o) a sidewall sheet section having a tubular portion through which said side tube runs;

7

- p) a lower wall sheet section having a tubular portion through which said lower tube runs;*
- q) an upper wall sheet section having a tubular portion through which said upper tube runs;*
- r) with each of the sidewall sheet section, lower wall sheet section and upper wall sheet section being engaged to an adjacent sheet section with stitching;*
- s) with each of the sidewall sheet section, lower wall sheet section and upper wall sheet section engaging mesh, with said mesh being on an interior of said wall;*

8

- t) wherein said counter member includes an upper portion for confronting a mattress of said second side of said bed, a lower portion for confronting a box spring of said second side of said bed, and a pair of apertures;*
- u) wherein said leg portion includes a piece riveted to said leg portion, and with said piece including a slot; and*
- v) wherein said strap engages in a looped fashion said pair of apertures of said counter member and wherein said strap engages said slot of said piece.*

* * * * *