



US007171773B2

(12) **United States Patent**
Haggard, Jr.

(10) **Patent No.:** **US 7,171,773 B2**
(45) **Date of Patent:** **Feb. 6, 2007**

(54) **HITCH MOUNTED BANNER DISPLAY SYSTEM**

(76) Inventor: **William Luther Haggard, Jr.**, 27339 Carl Dr., Harvest, AL (US) 35749

(*) Notice: Subject to any disclaimer, the term of this patent is extended or adjusted under 35 U.S.C. 154(b) by 0 days.

(21) Appl. No.: **11/095,708**

(22) Filed: **Mar. 31, 2005**

(65) **Prior Publication Data**

US 2005/0229454 A1 Oct. 20, 2005

Related U.S. Application Data

(63) Continuation-in-part of application No. 10/616,616, filed on Jul. 10, 2003, now Pat. No. 6,892,486, which is a continuation of application No. 09/881,496, filed on Jun. 14, 2001, now abandoned.

(51) **Int. Cl.**
G09F 21/04 (2006.01)

(52) **U.S. Cl.** **40/591; 40/604**

(58) **Field of Classification Search** **40/590, 40/591, 643; 224/519, 521**
See application file for complete search history.

(56) **References Cited**

U.S. PATENT DOCUMENTS

- 1,406,916 A 2/1922 Arnold
- 2,243,912 A 6/1941 Legler
- 2,865,124 A 12/1958 Mortellito
- 3,148,856 A 9/1964 Orlando
- 3,208,173 A 9/1965 Shank
- 3,494,405 A 2/1970 Sandahl et al.
- 3,633,299 A 1/1972 Westlin
- 3,698,114 A 10/1972 Hirsch et al.
- 3,818,599 A 6/1974 Tague
- 3,955,786 A 5/1976 Duddy
- 3,966,231 A 6/1976 Metzler
- 4,012,056 A 3/1977 Christensen

- 4,169,610 A 10/1979 Paufler
- 4,241,530 A 12/1980 Hartvig
- 4,365,435 A 12/1982 Snyder
- 4,574,726 A 3/1986 Sullivan
- 4,666,176 A 5/1987 Sand
- 4,667,428 A 5/1987 Elmer
- 4,700,655 A 10/1987 Kirby
- 4,723,788 A 2/1988 Suter
- 4,866,866 A 9/1989 Rotter et al.

(Continued)

FOREIGN PATENT DOCUMENTS

DE 26 11 922 9/1977

(Continued)

Primary Examiner—Cassandra Davis

(74) *Attorney, Agent, or Firm*—Luedeka, Neely & Graham, P.C.

(57) **ABSTRACT**

A display system for use with a trailer hitch, the display system including a banner and a frame to support the banner. The frame includes a pair of vertical frame members and a frame support is provided to support the frame. The frame support includes a first elongate member positionable adjacent the frame and configured for connection of the vertical frame members to the frame support, and a second elongate member extending from the first elongate member. A support connector is provided having a first portion thereof configured to receive the second elongate member of the frame support and a second portion thereof configured to be connectable with the trailer hitch.

6 Claims, 14 Drawing Sheets

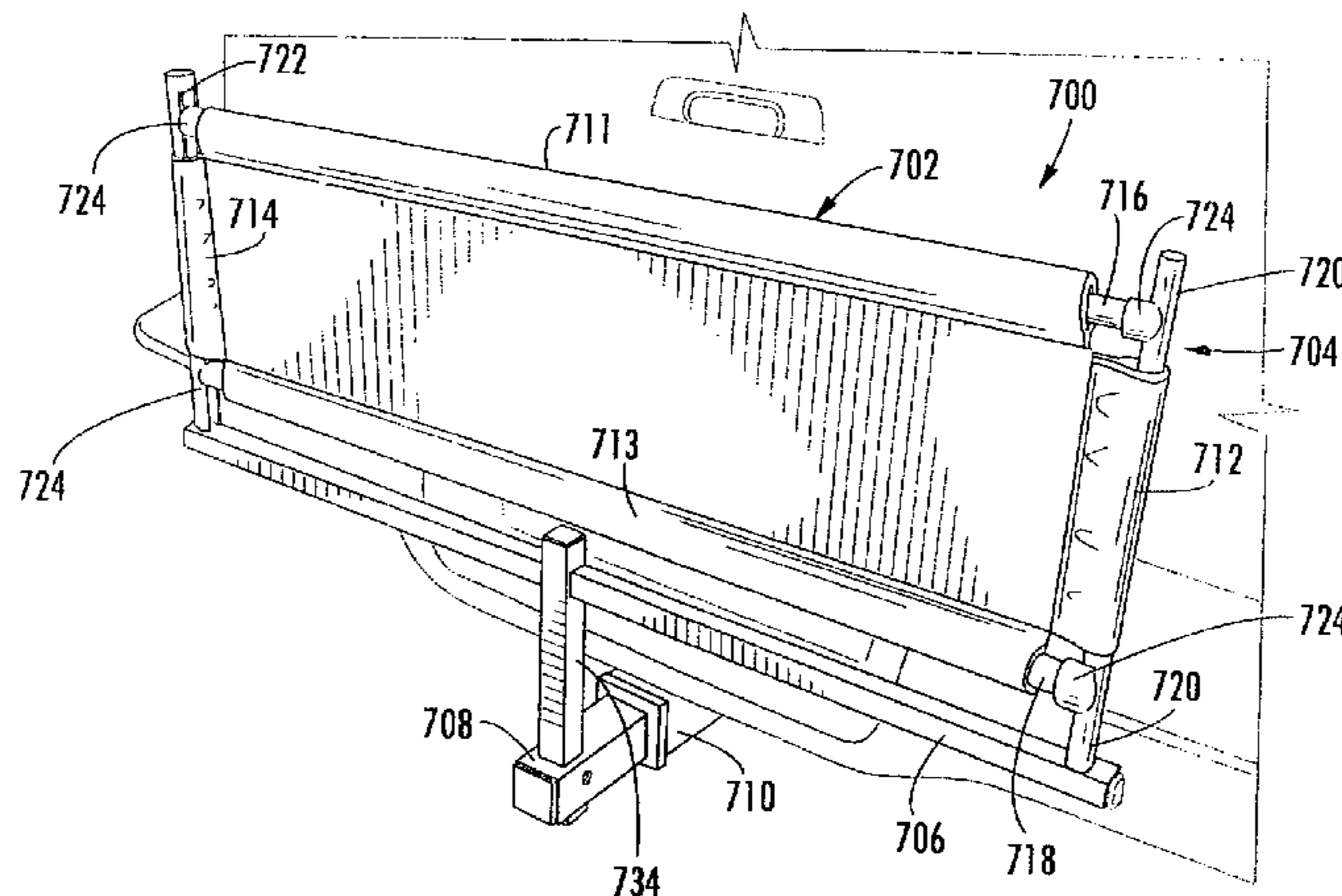

US 7,171,773 B2

Page 2

U.S. PATENT DOCUMENTS

4,878,303 A 11/1989 Banniza et al.
4,937,962 A 7/1990 Hornblad
5,113,588 A 5/1992 Walston
5,172,505 A 12/1992 Borsella
5,181,284 A 1/1993 Raphael et al.
5,269,554 A 12/1993 Law et al.
5,502,909 A 4/1996 Rabkin
5,558,352 A 9/1996 Mills
5,570,826 A * 11/1996 Garbes et al. 224/524
D378,669 S 4/1997 Gregory
5,737,862 A 4/1998 Cooper et al.
6,119,384 A * 9/2000 Fischer 40/606.02

6,618,973 B2 9/2003 Nelson
6,643,963 B2 * 11/2003 Beller 40/590
6,734,792 B1 * 5/2004 McElveen 340/468
6,892,486 B2 5/2005 Haggard, Jr.
2003/0164436 A1 * 9/2003 Rooker 248/441.1
2005/0188572 A1 9/2005 Haggard, Jr.

FOREIGN PATENT DOCUMENTS

FR 2 821 970 A1 * 9/2002
GB 2 029 621 A * 3/1980
GB 2 360 021 A 7/2000
WO 95/20208 7/1995

* cited by examiner

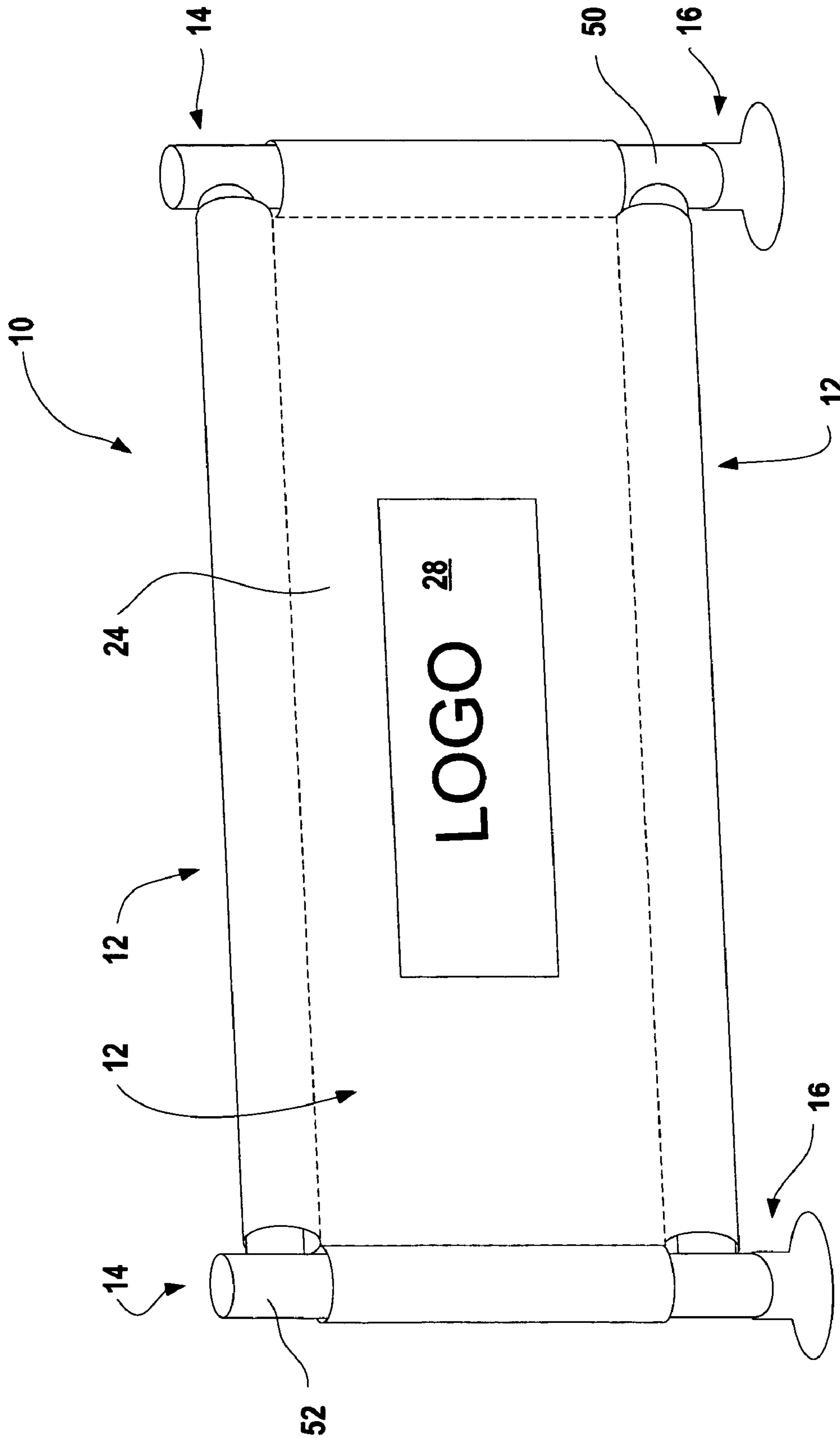

Fig. 1

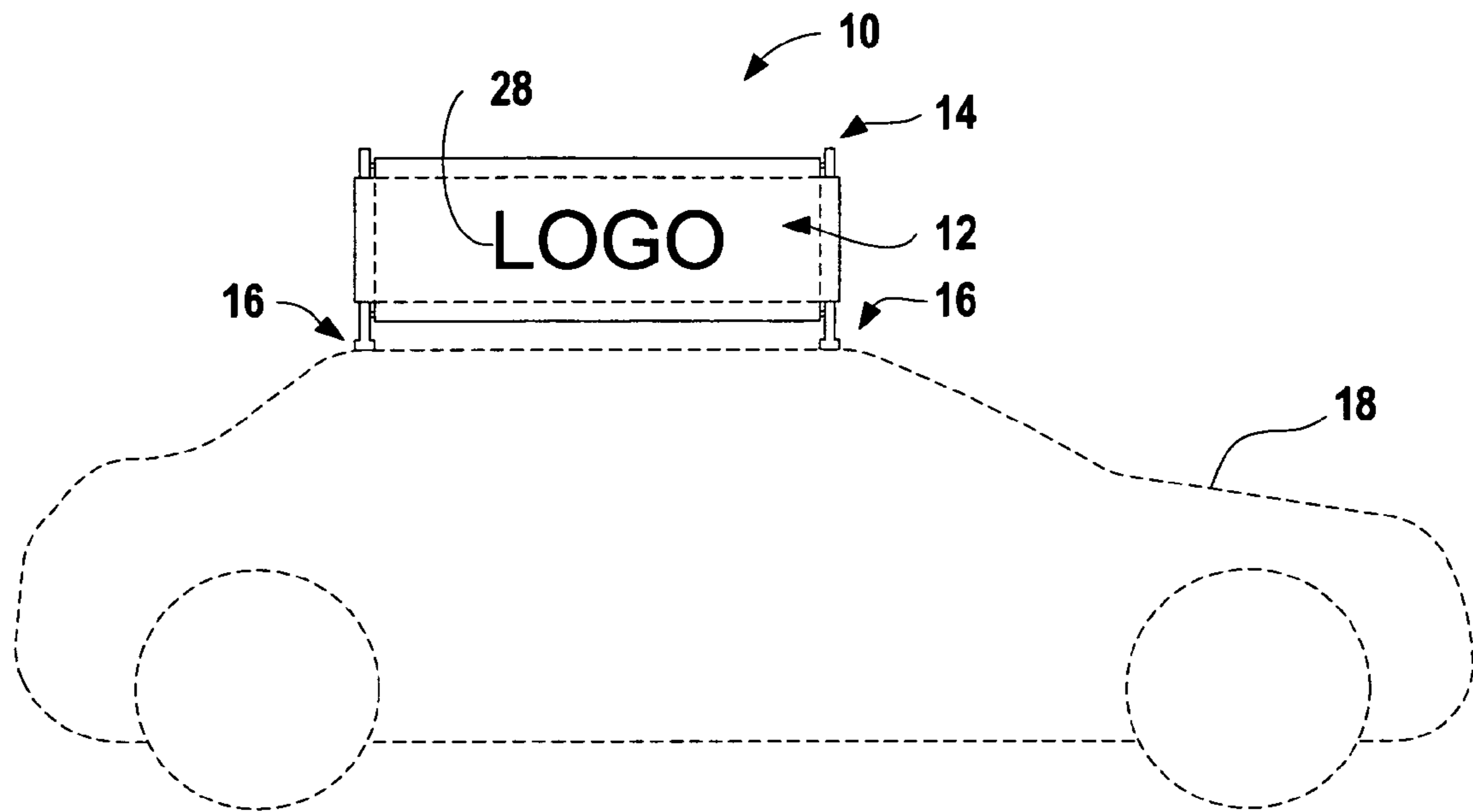

Fig. 1a

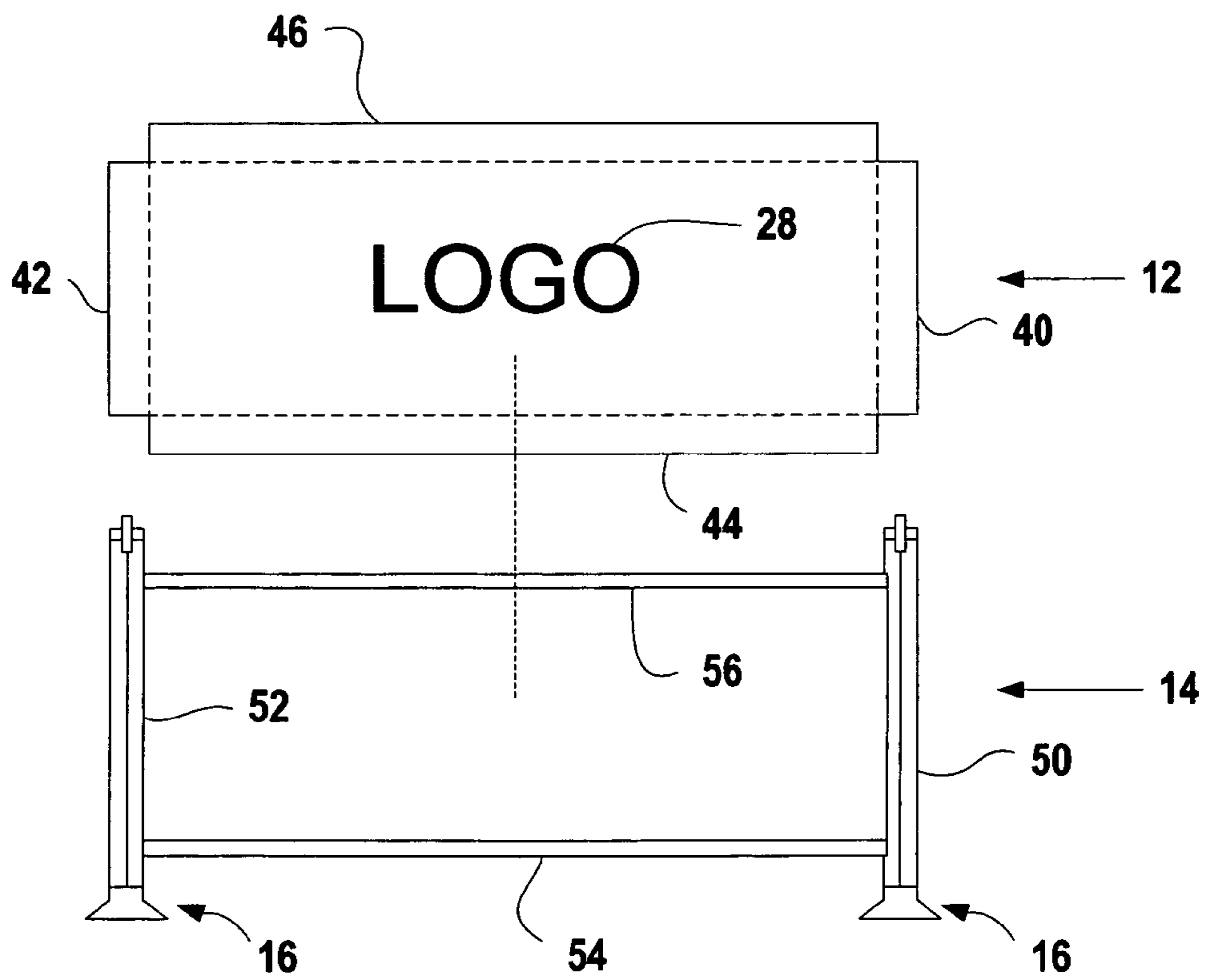

Fig. 2

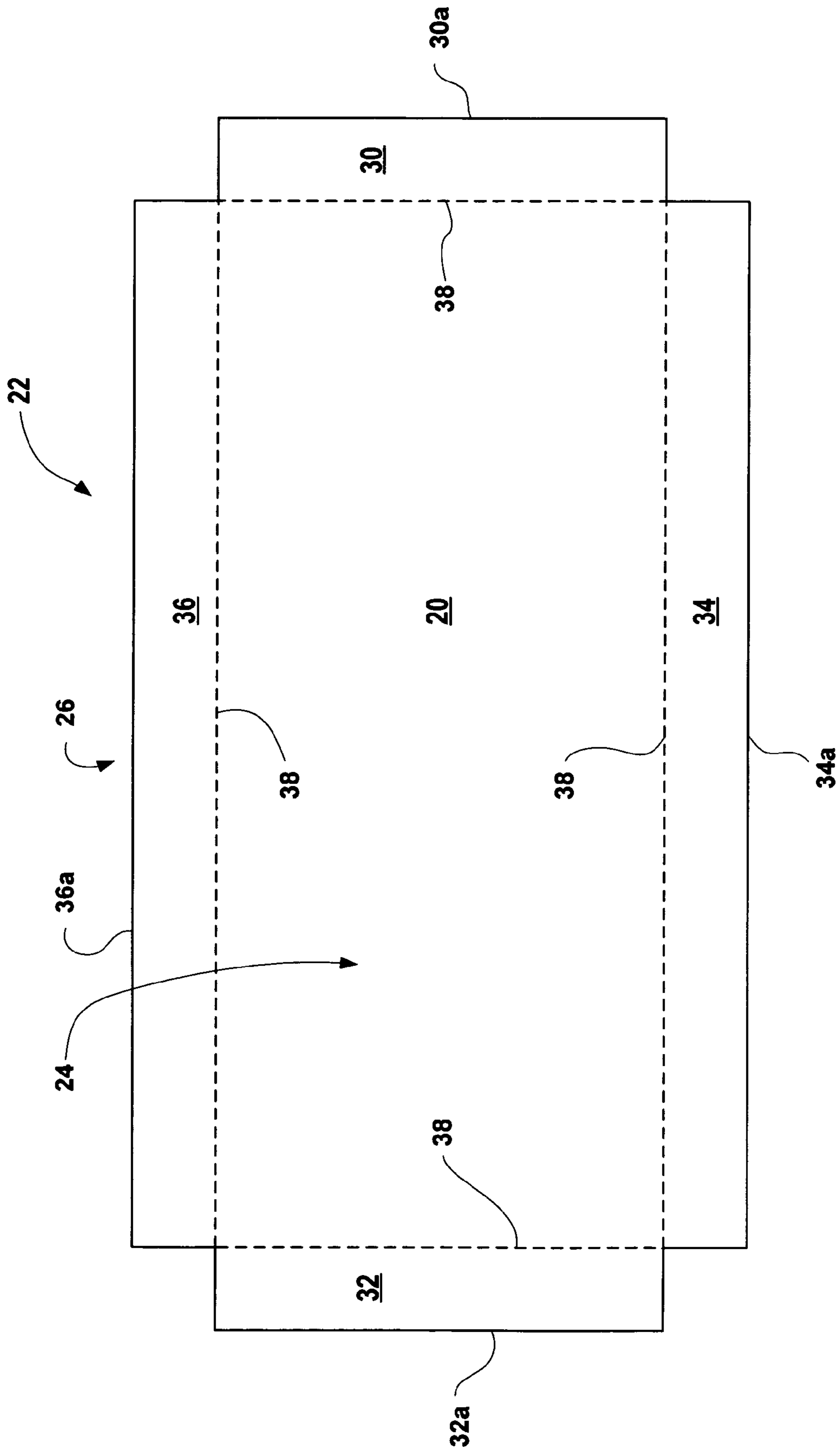

Fig. 2a

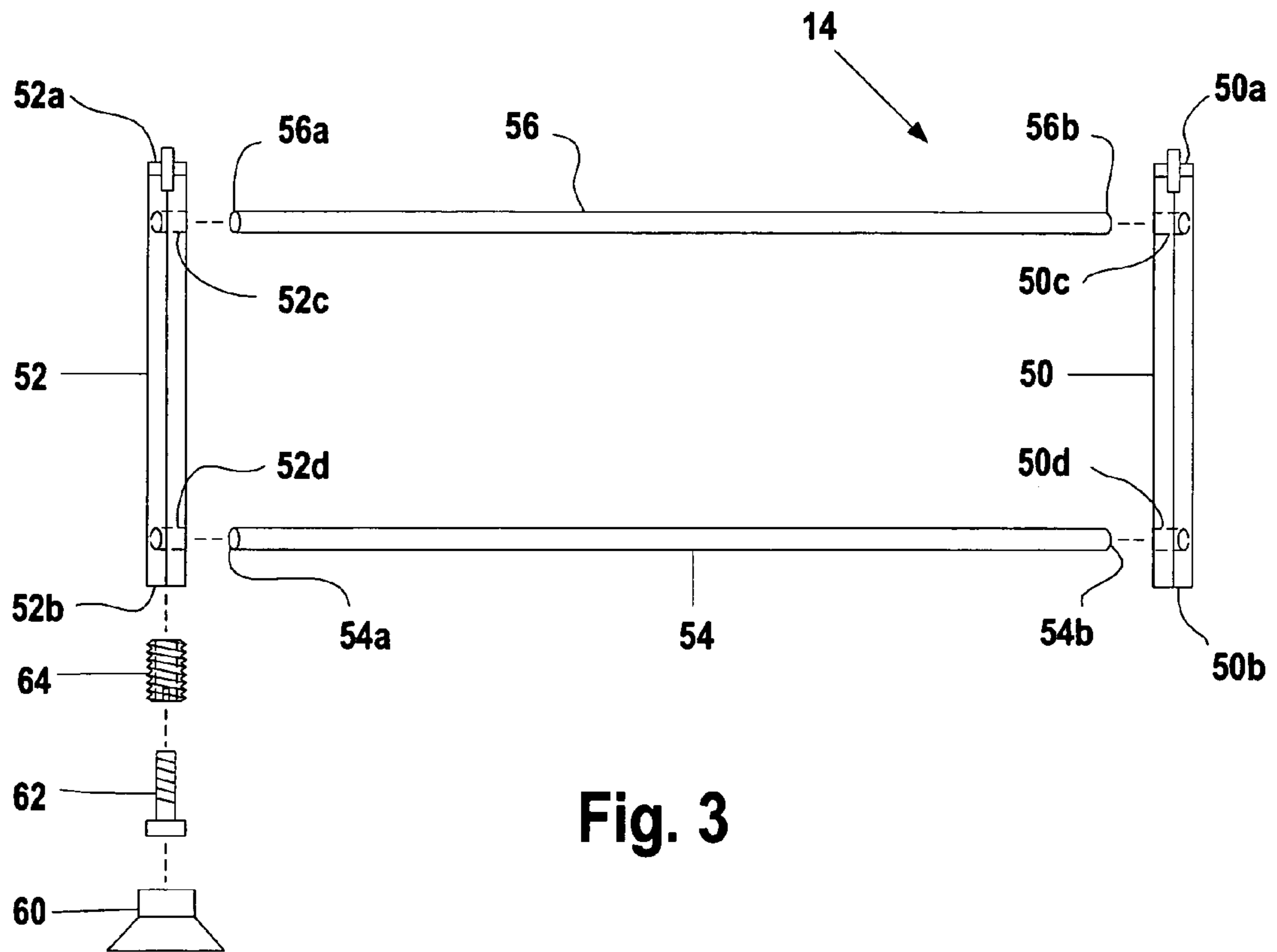

Fig. 3

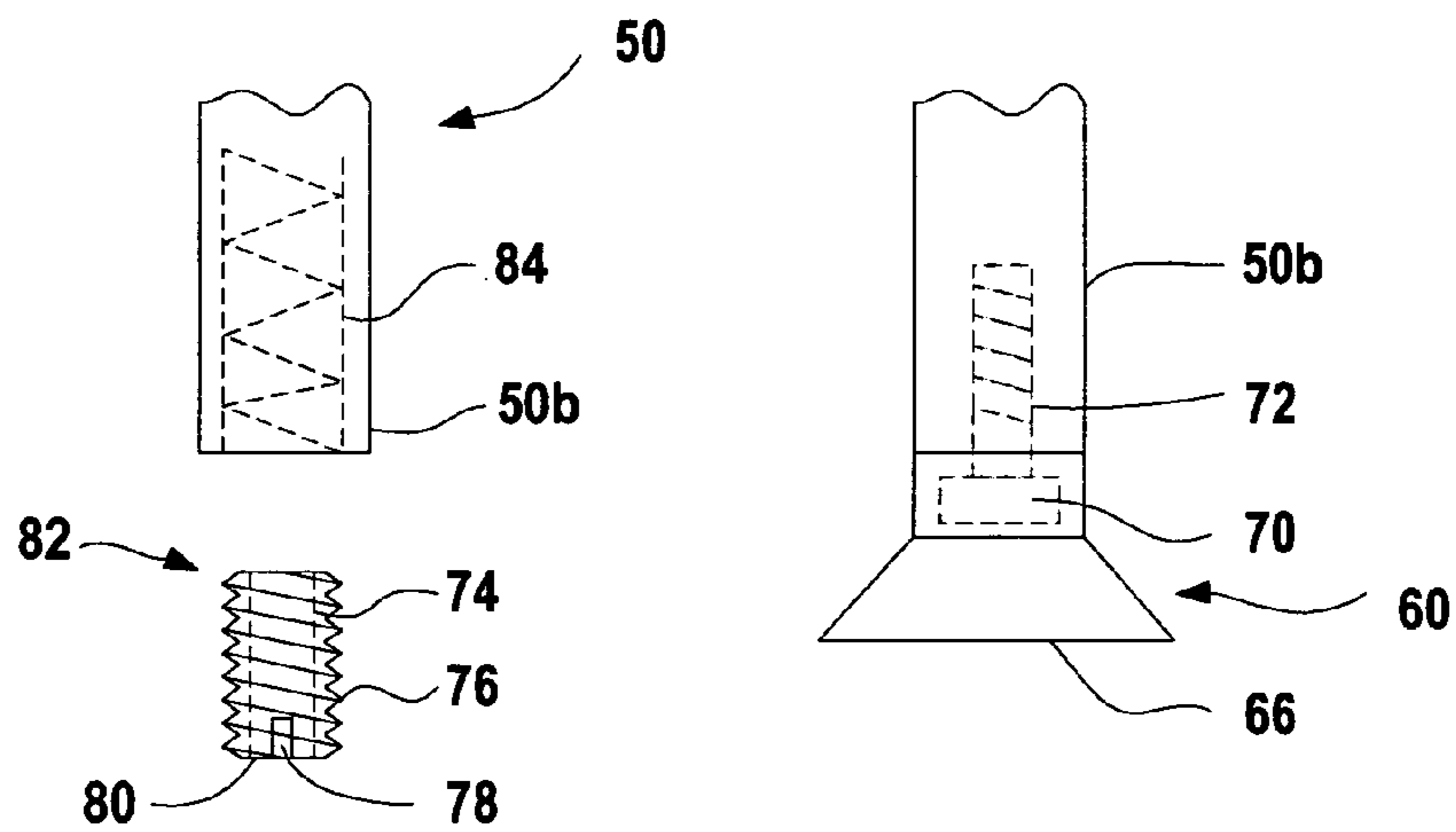
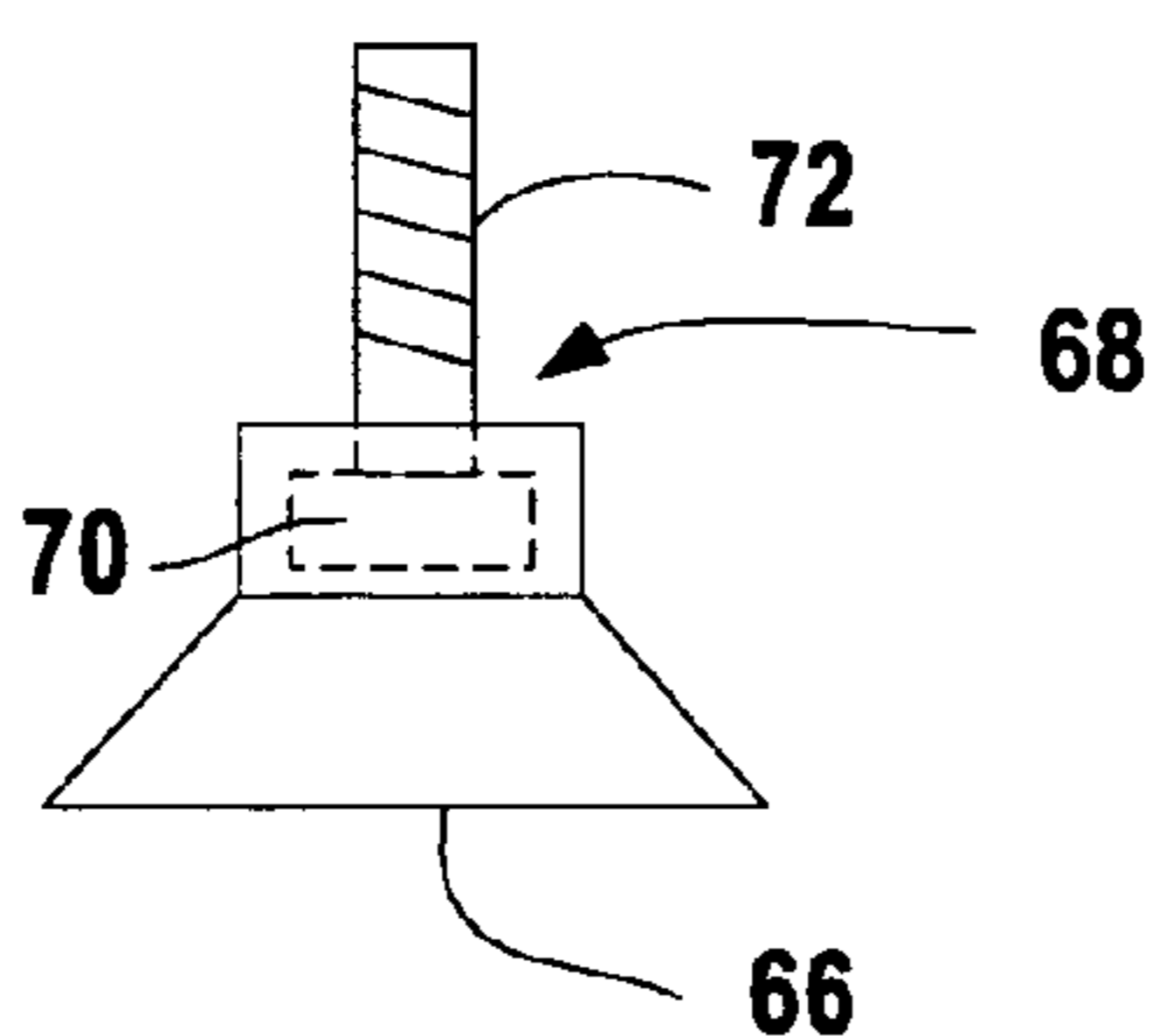

Fig. 3a

Fig. 3b



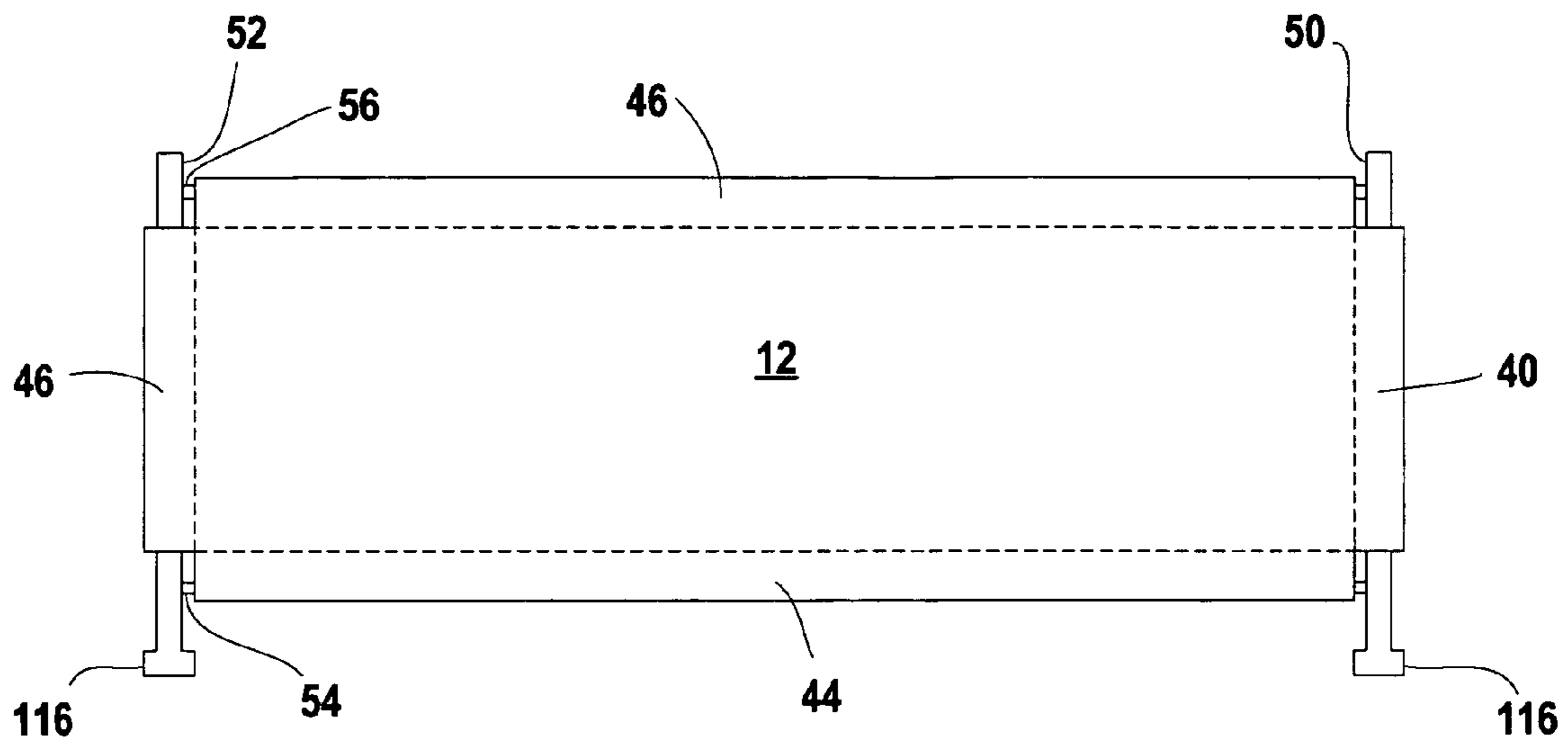

Fig. 4

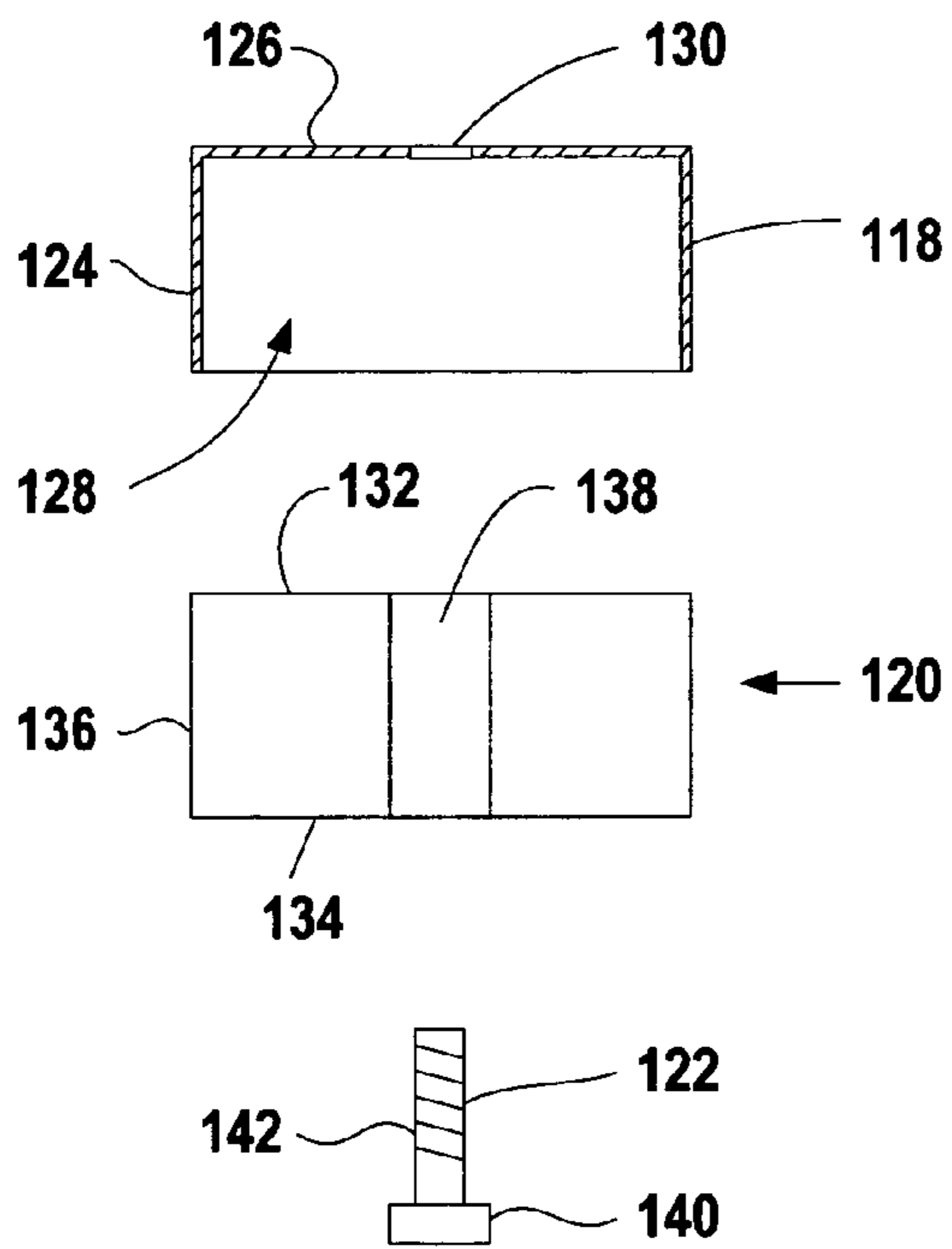

Fig. 5

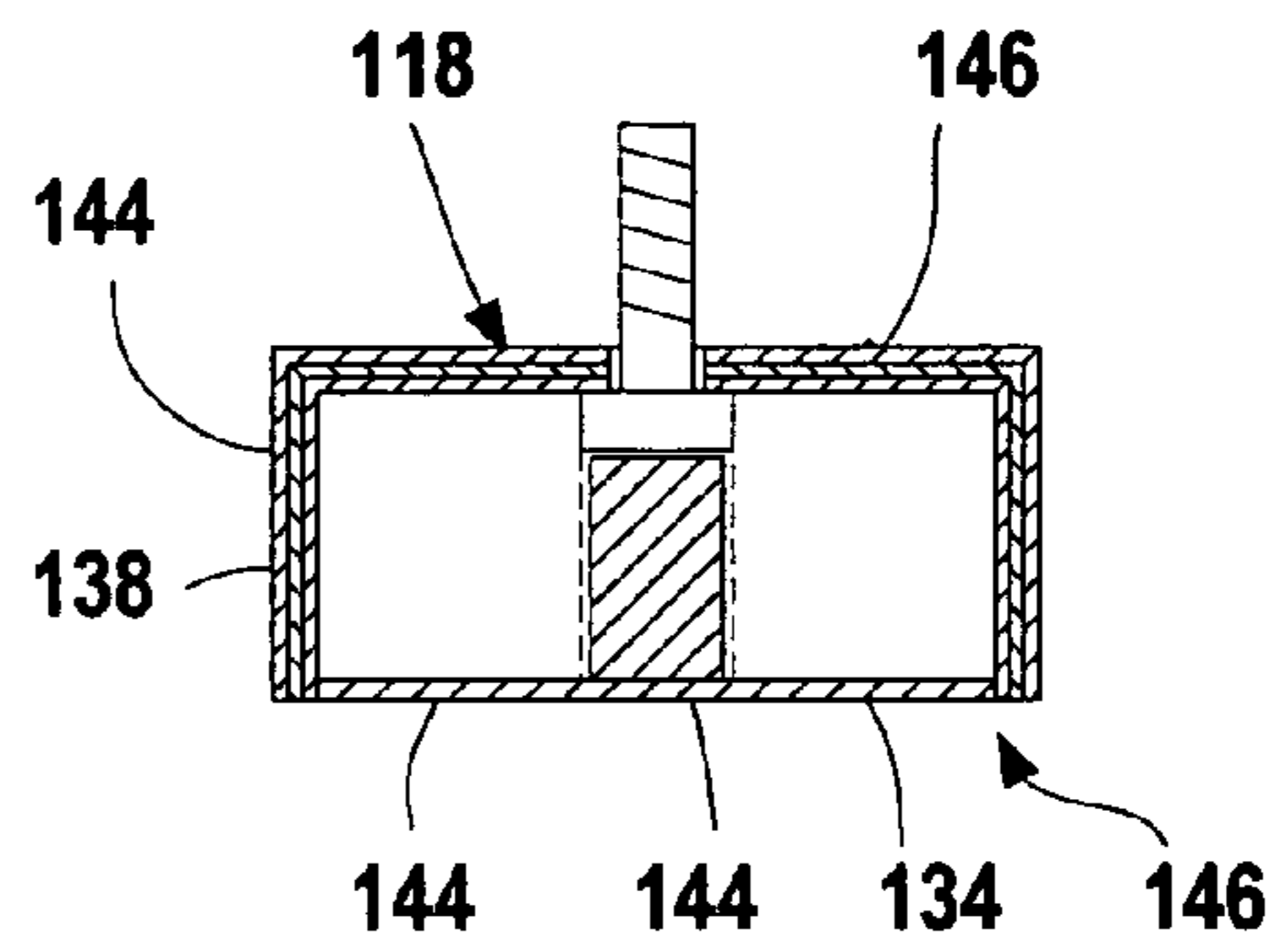

Fig. 6

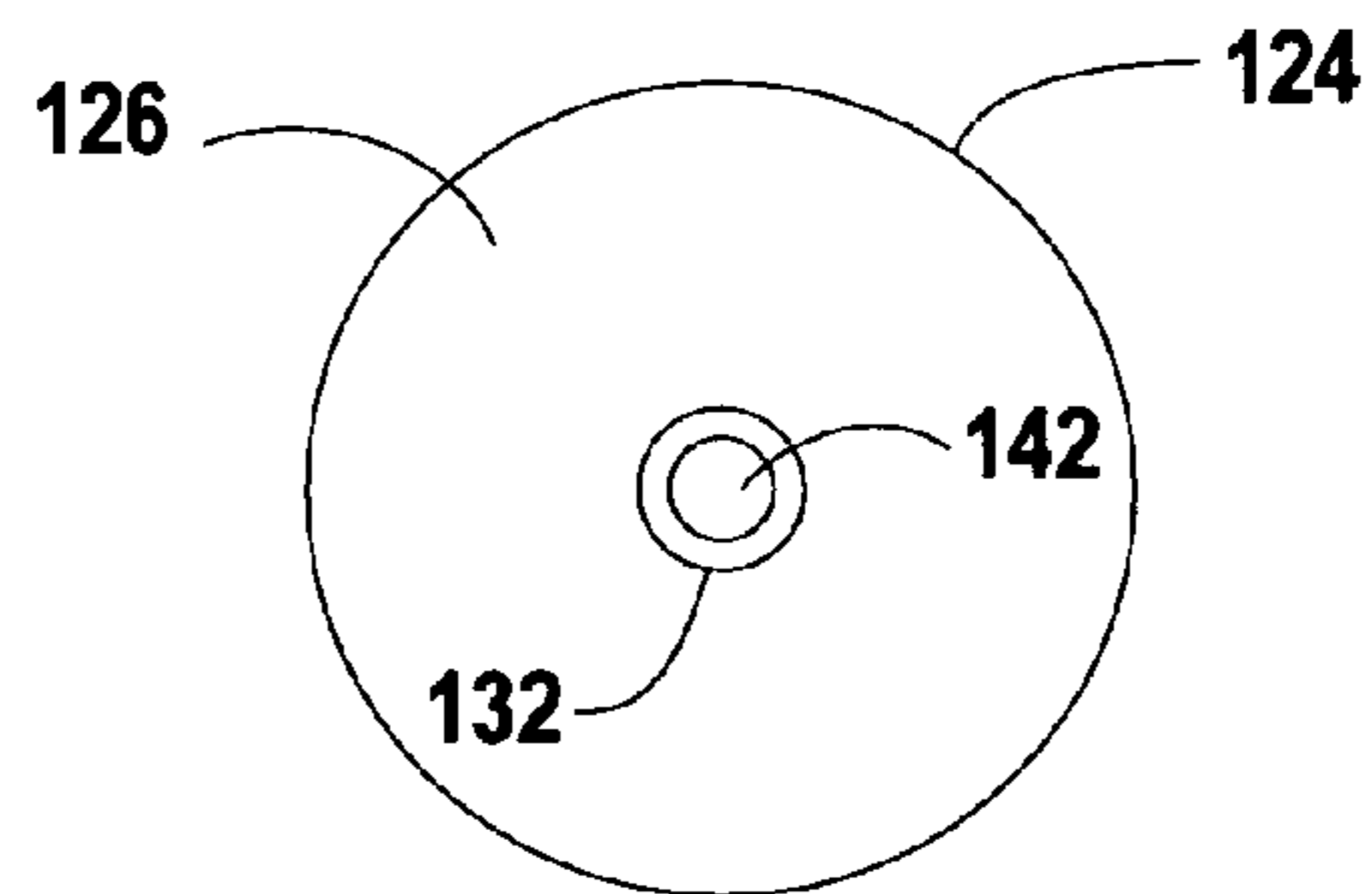

Fig. 6a

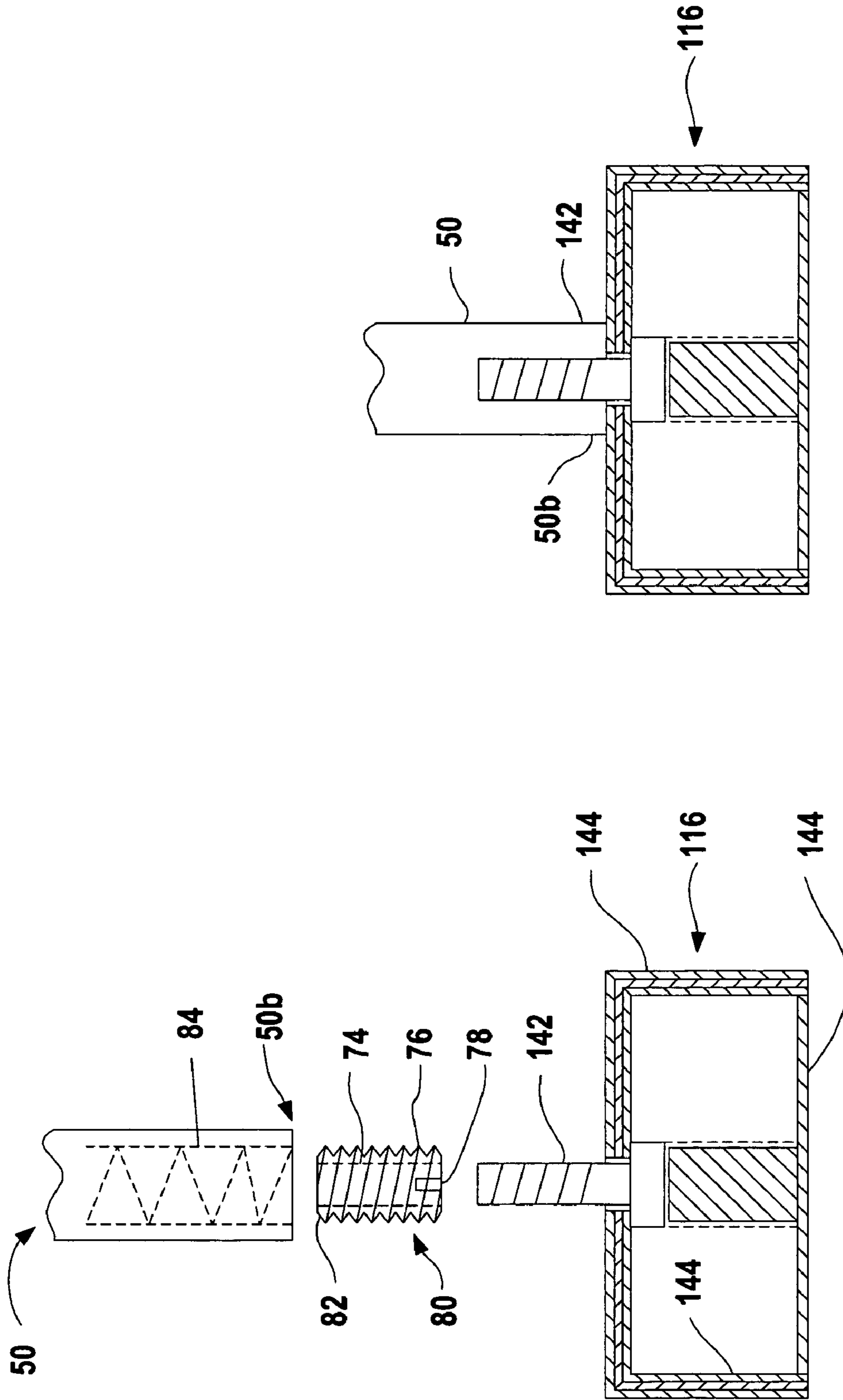

Fig. 7

Fig. 8

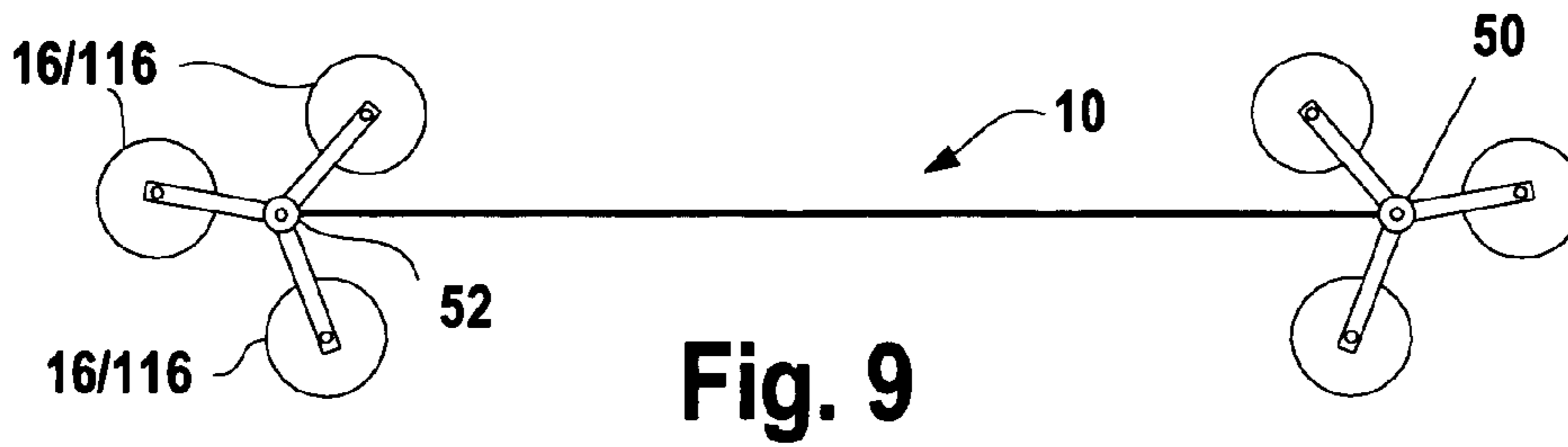

Fig. 9

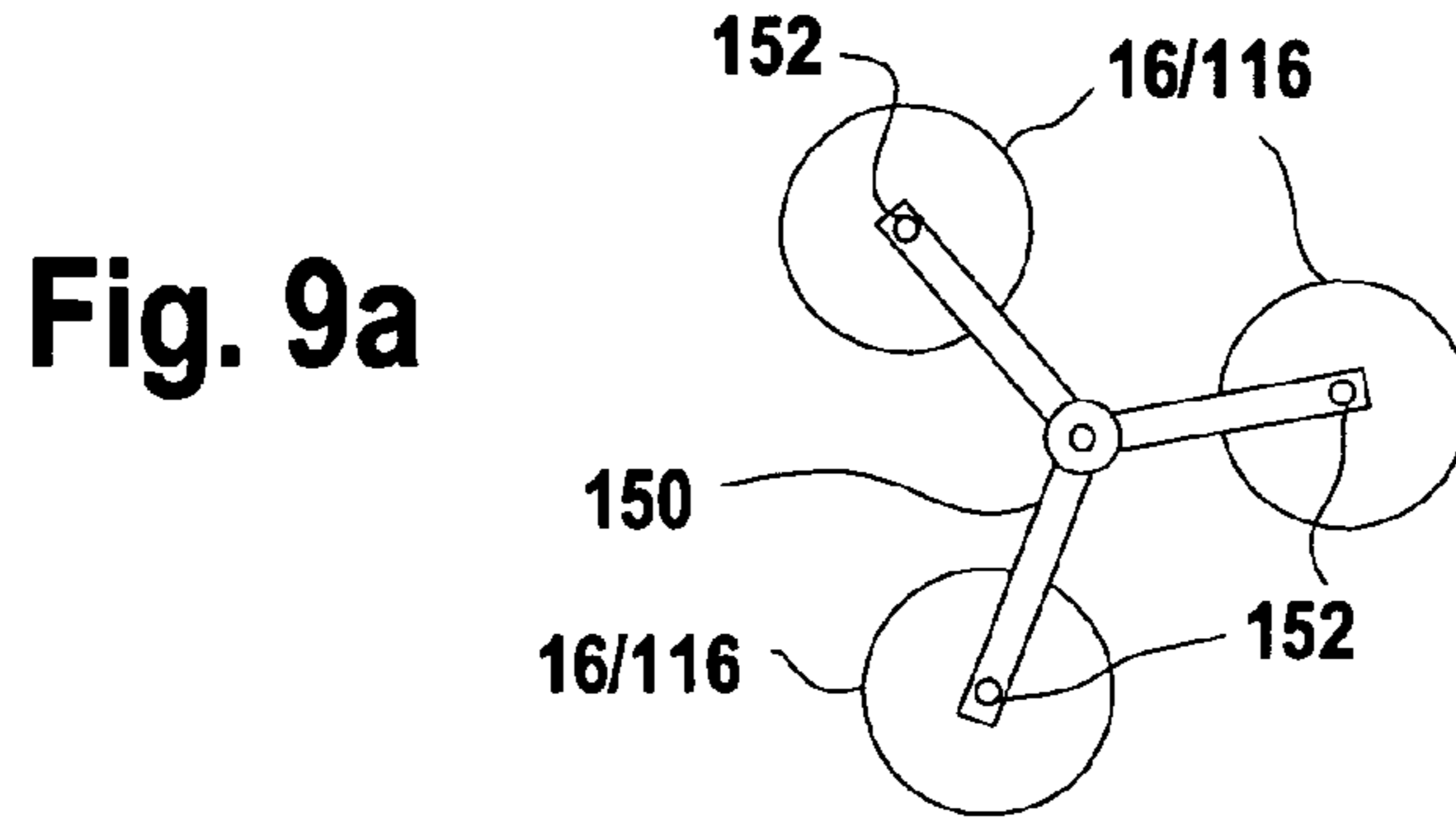

Fig. 9a

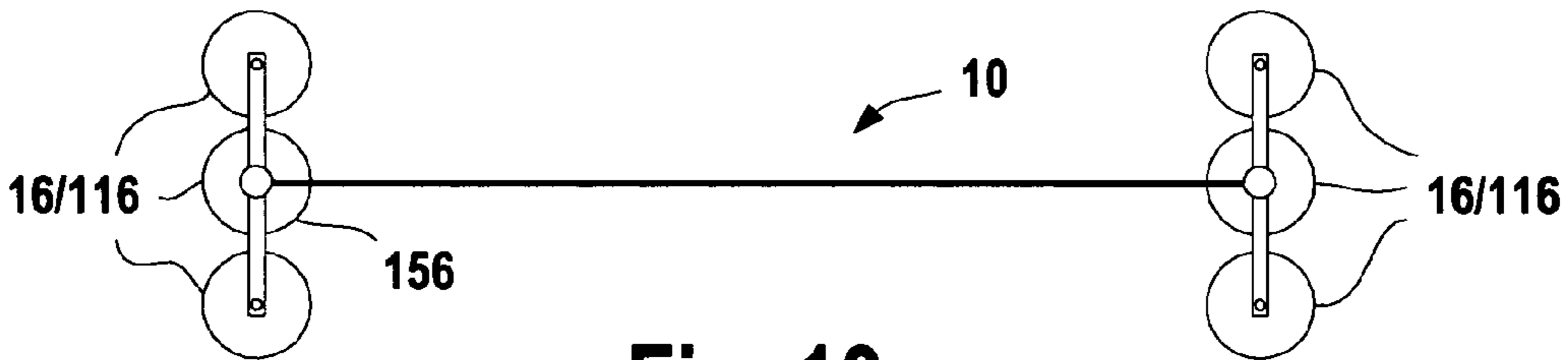

Fig. 10

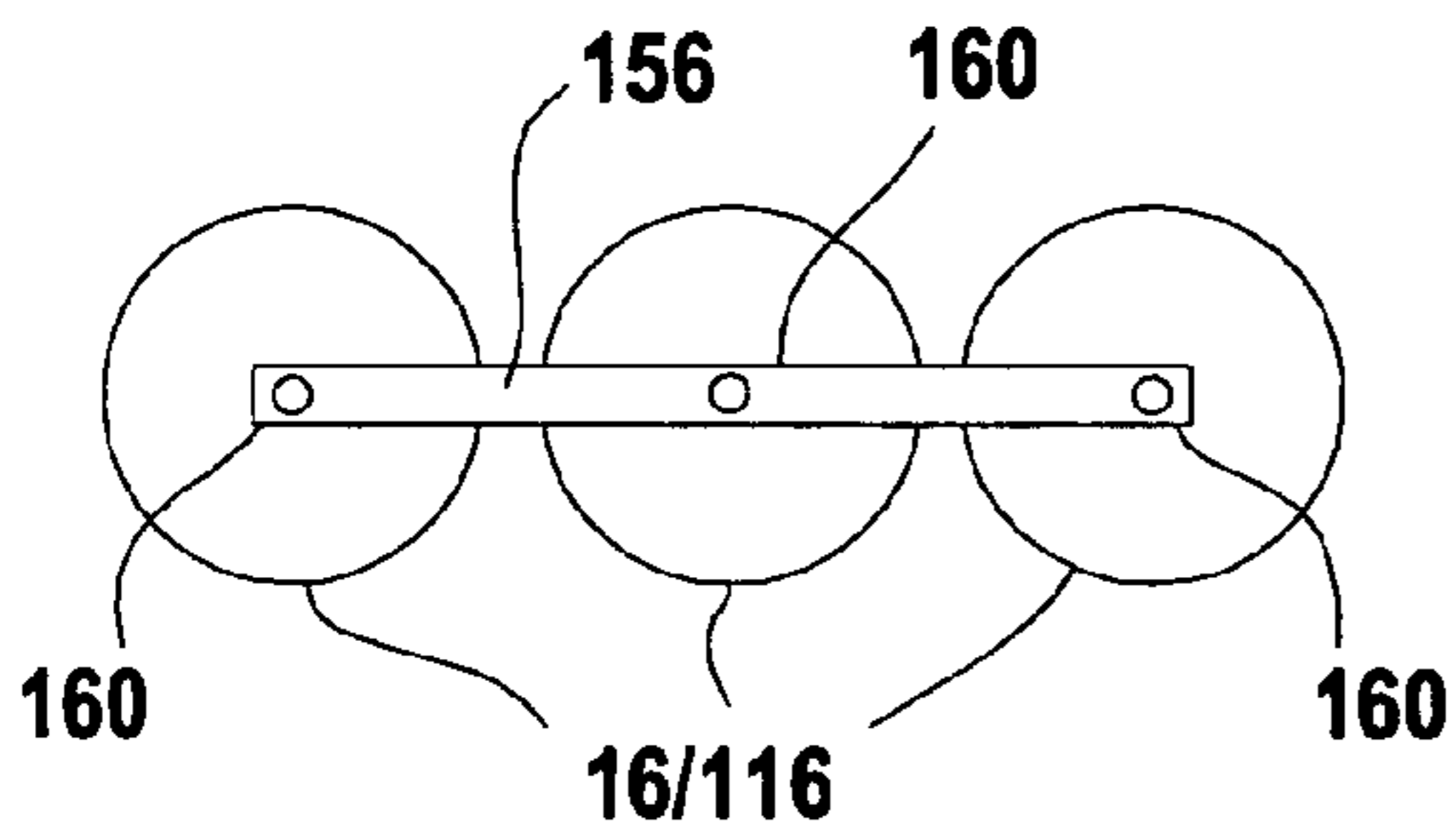

Fig. 10a

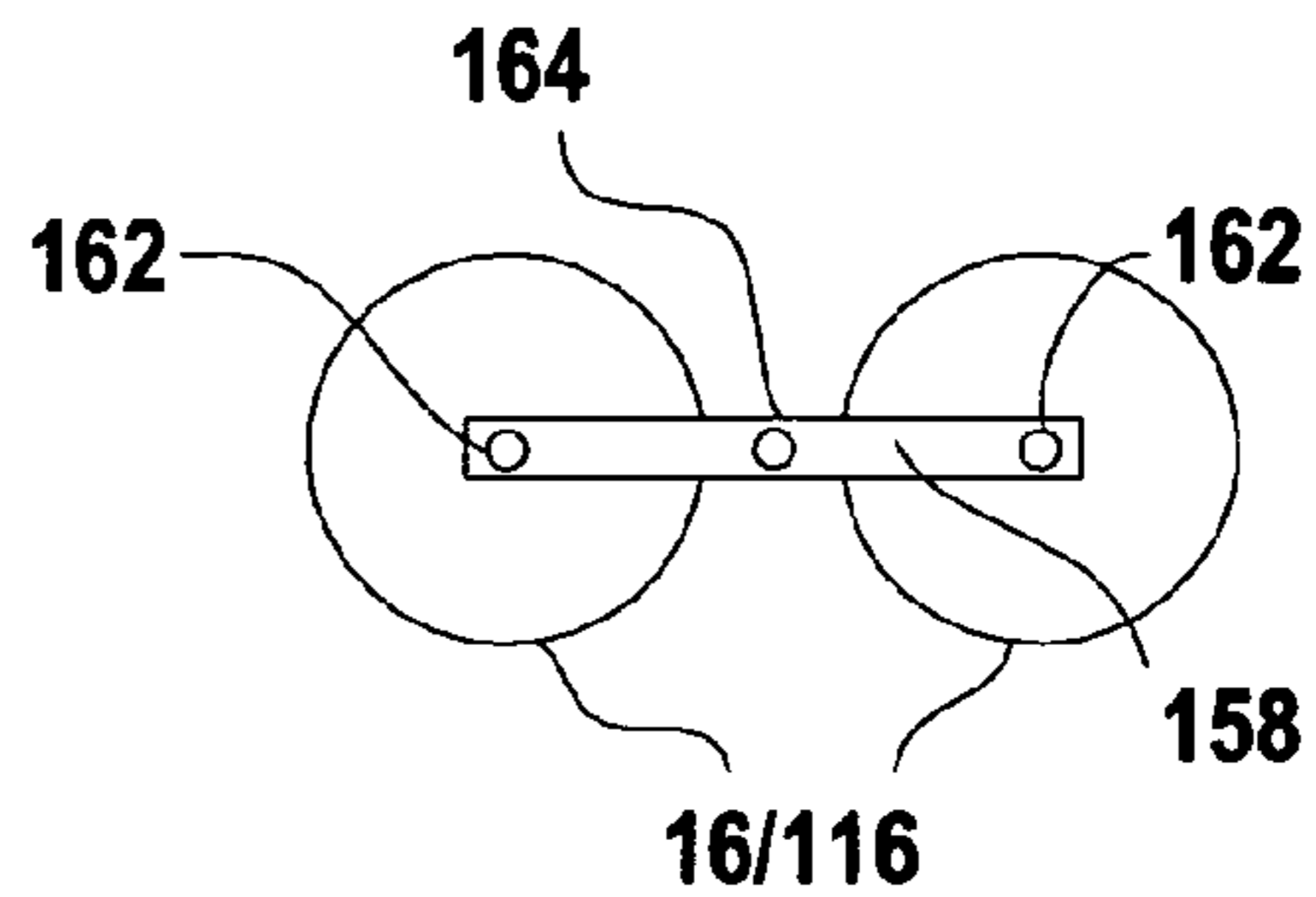

Fig. 11a

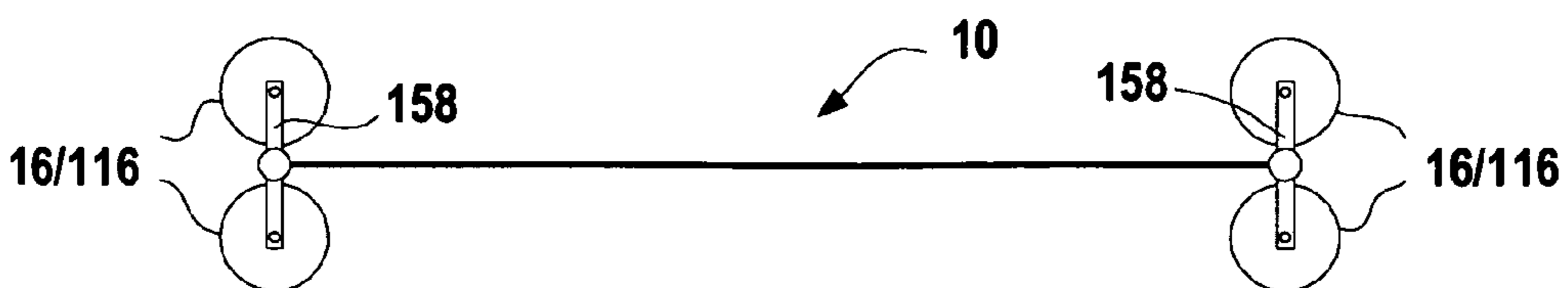

Fig. 11

Fig. 12

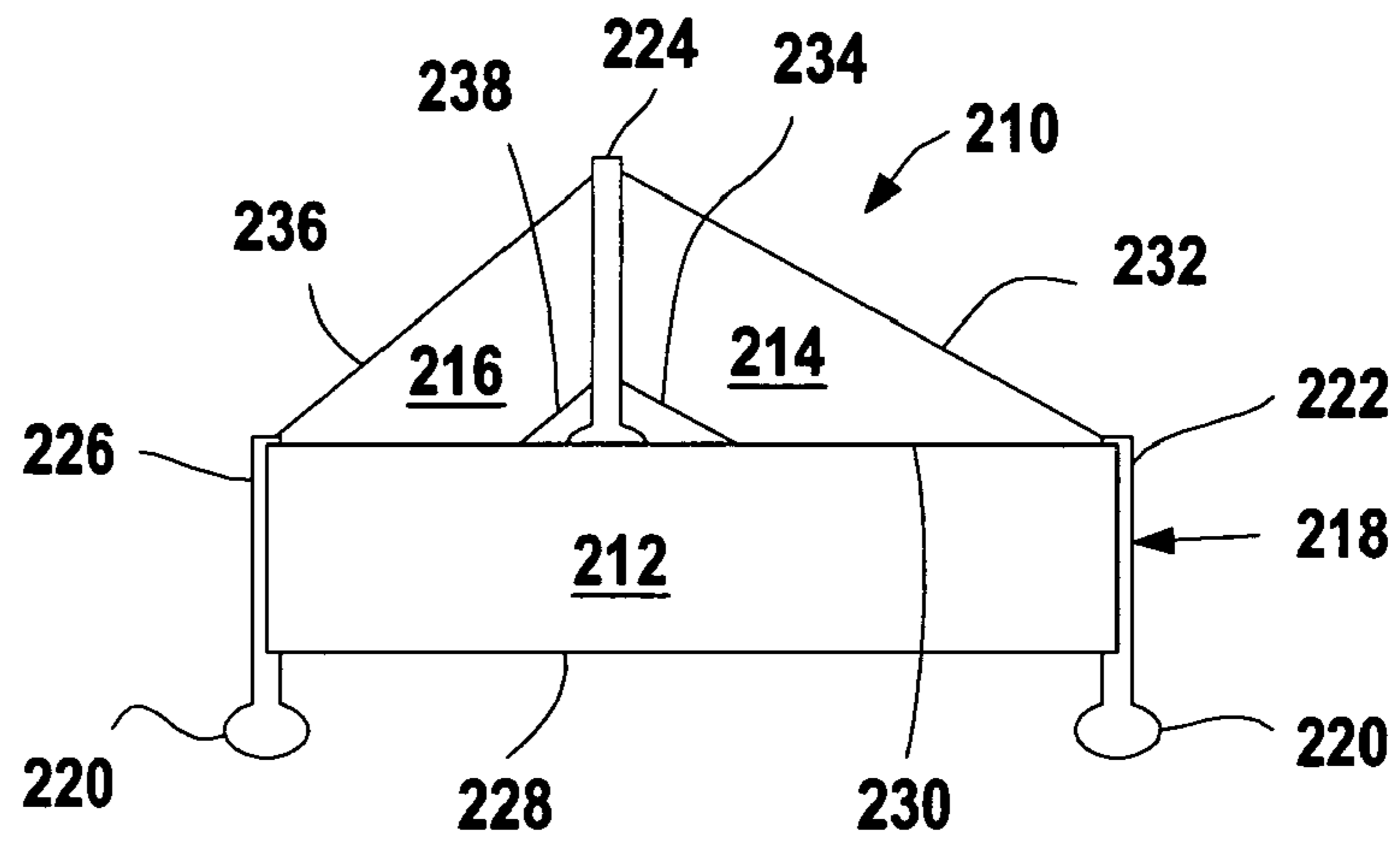

Fig. 12a

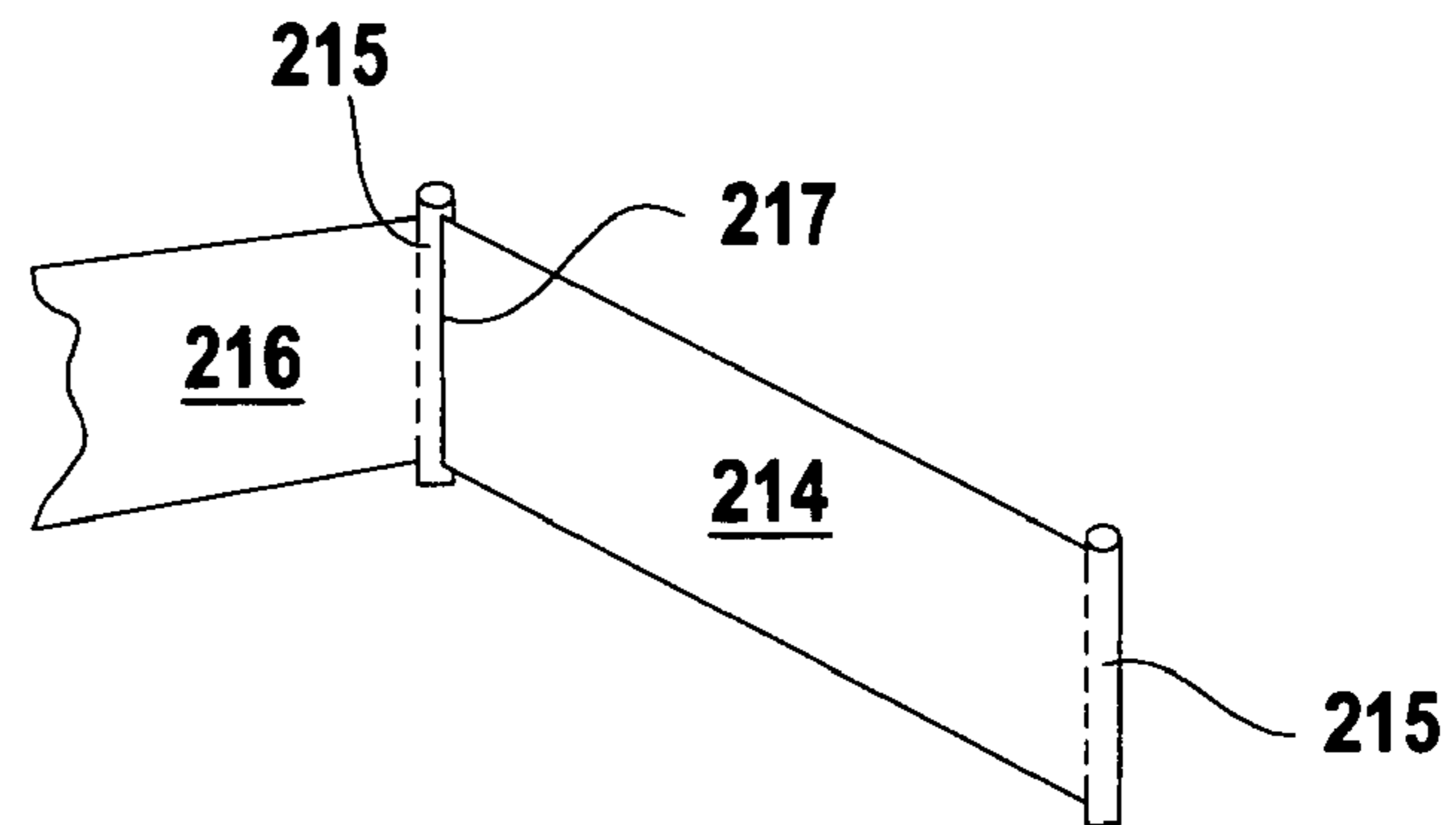

Fig. 12b

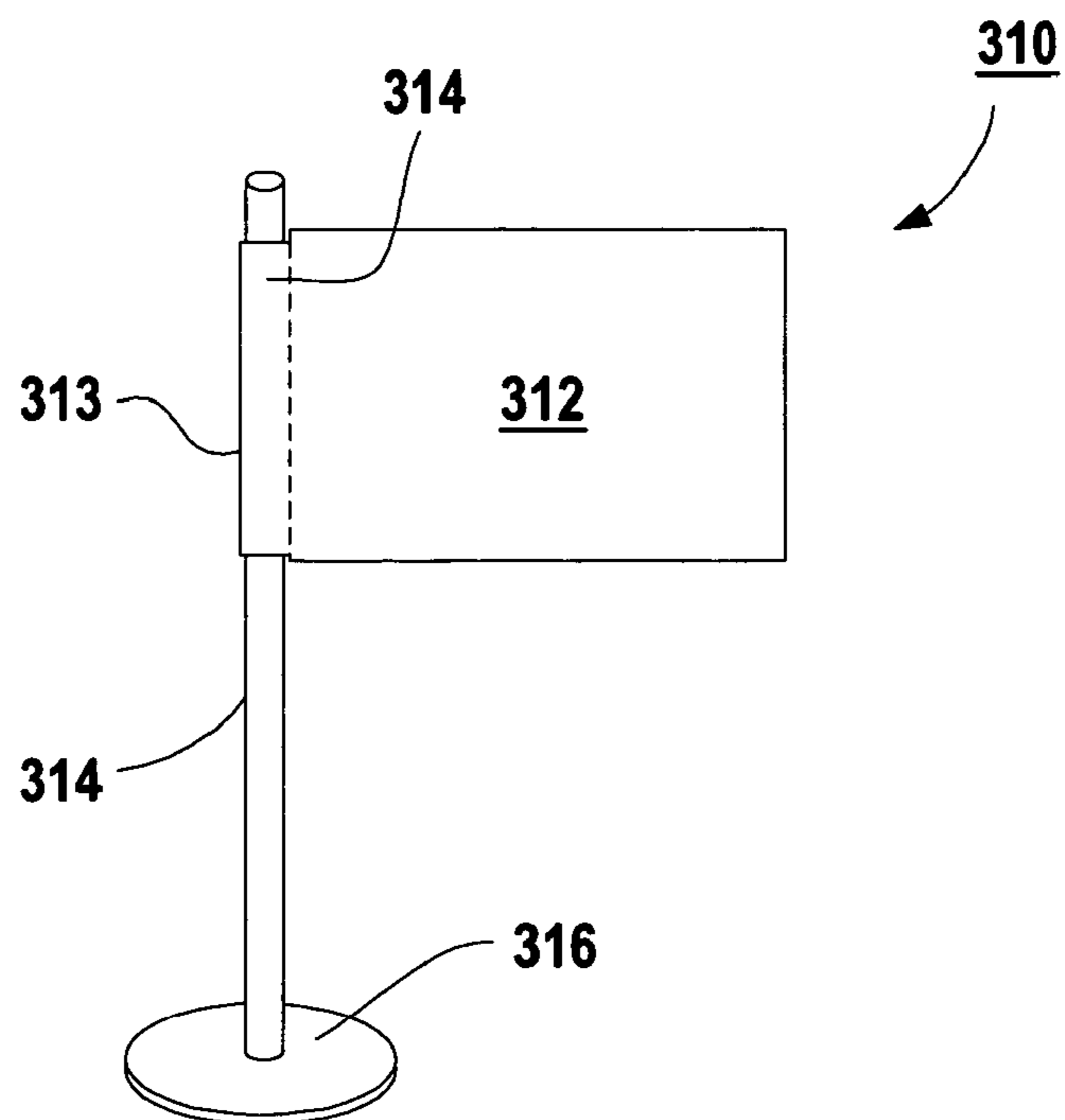

Fig. 13

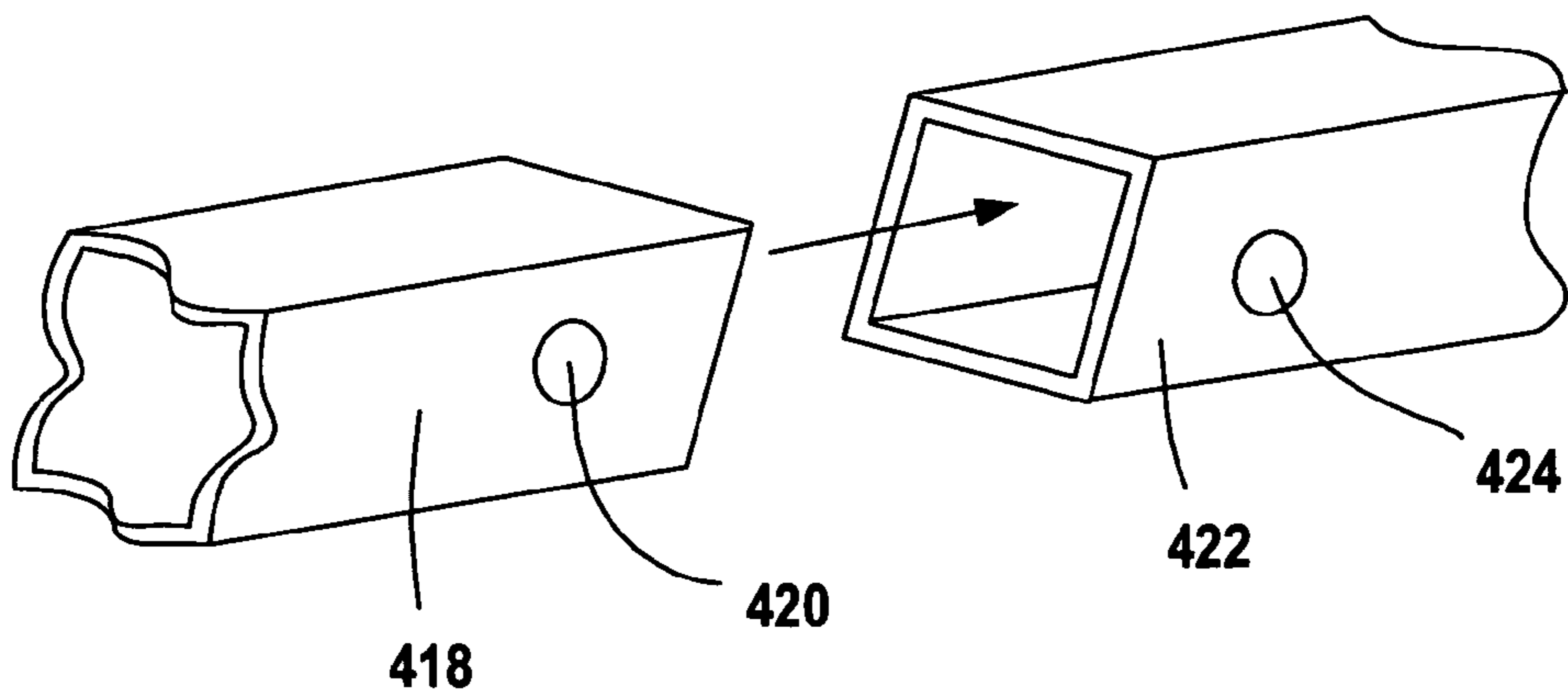
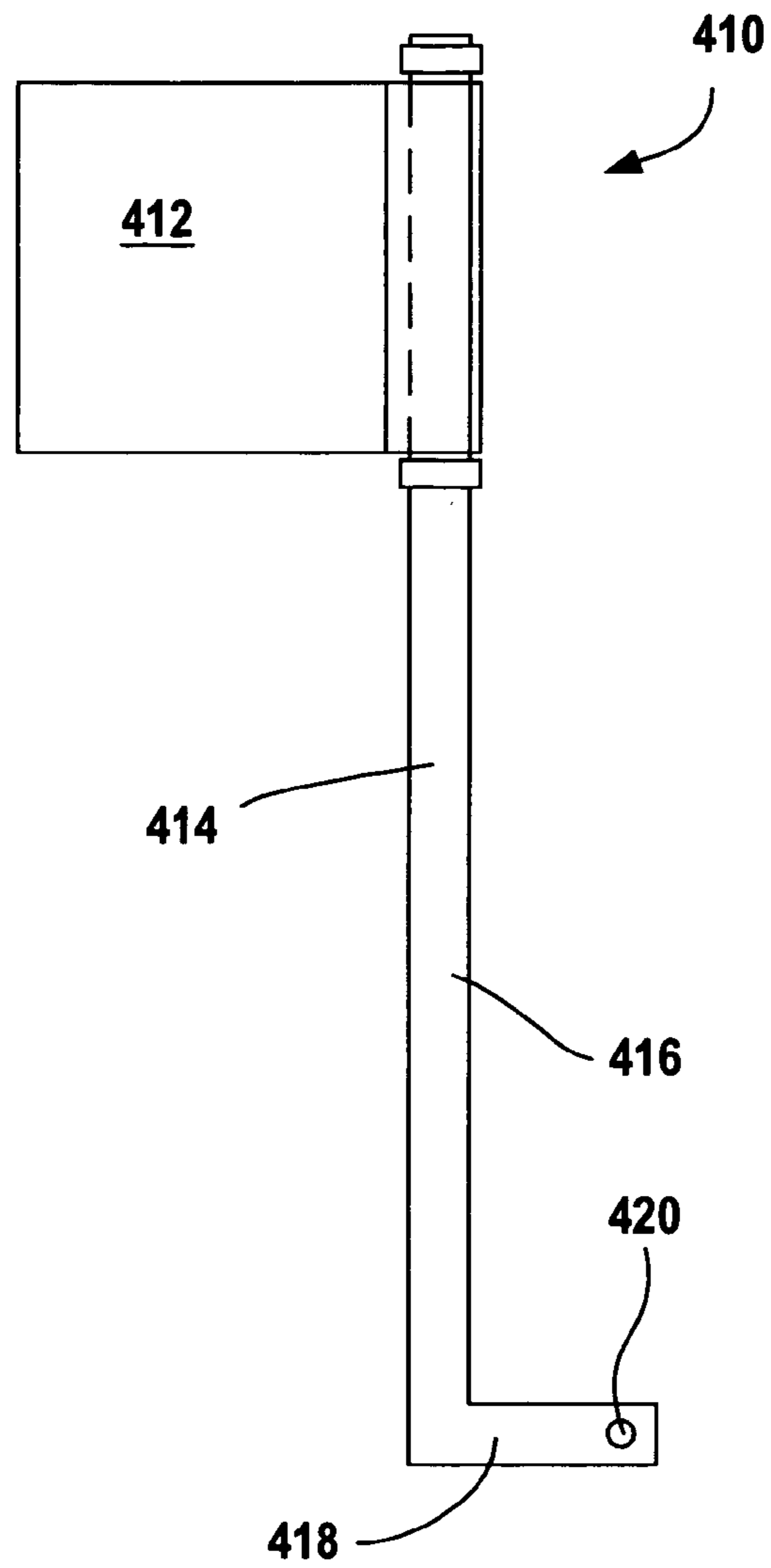

Fig. 14

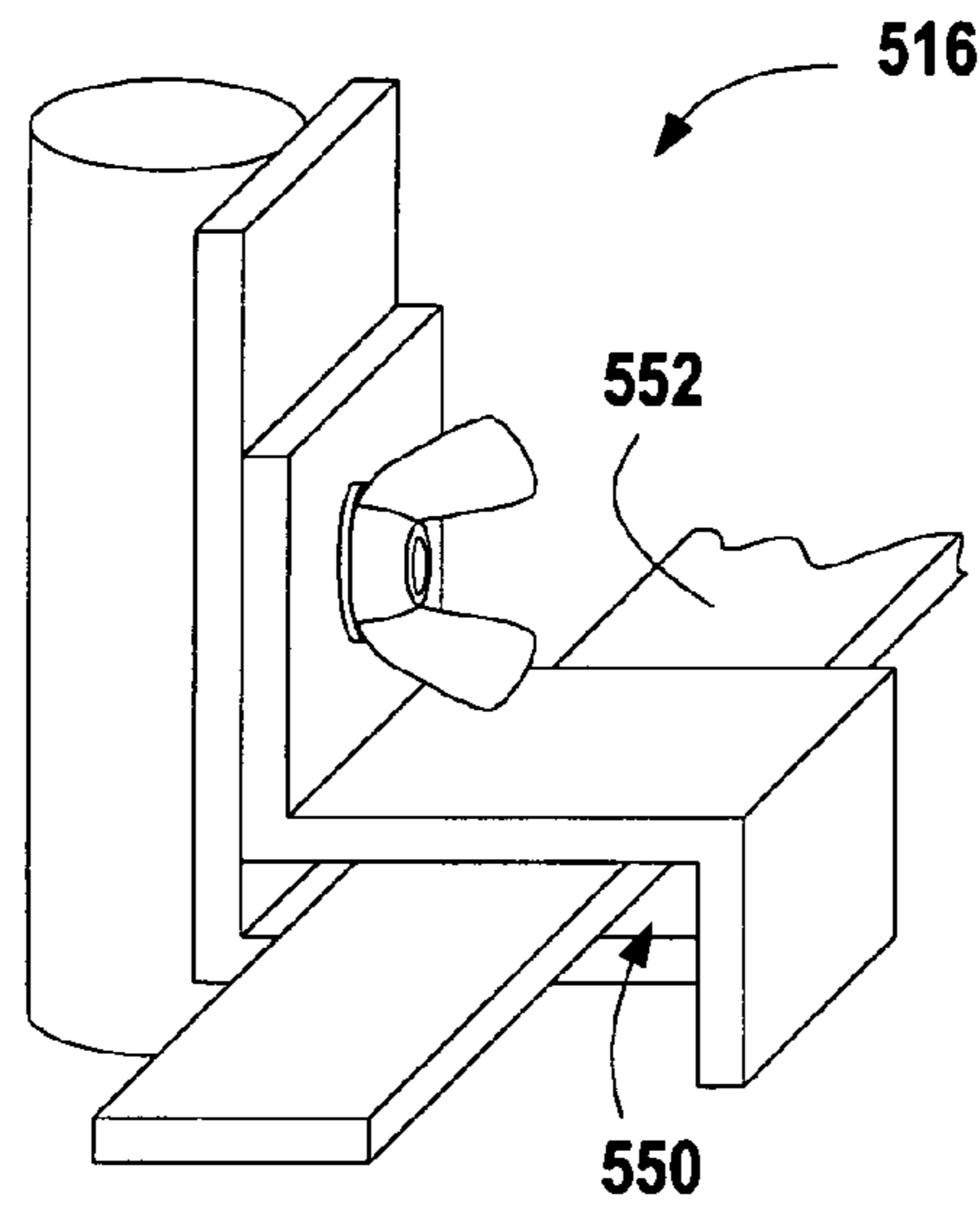

Fig. 15

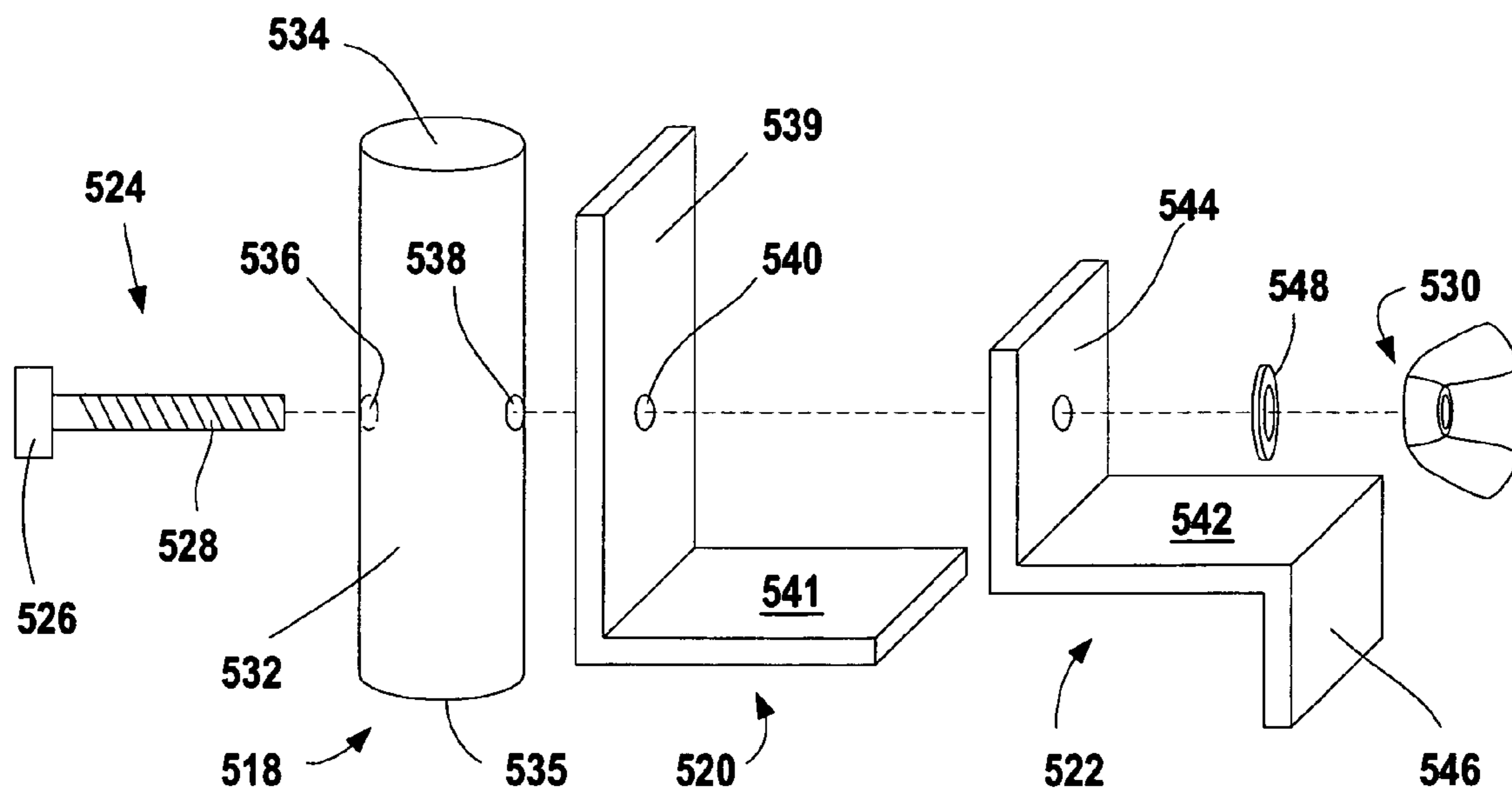

Fig. 16

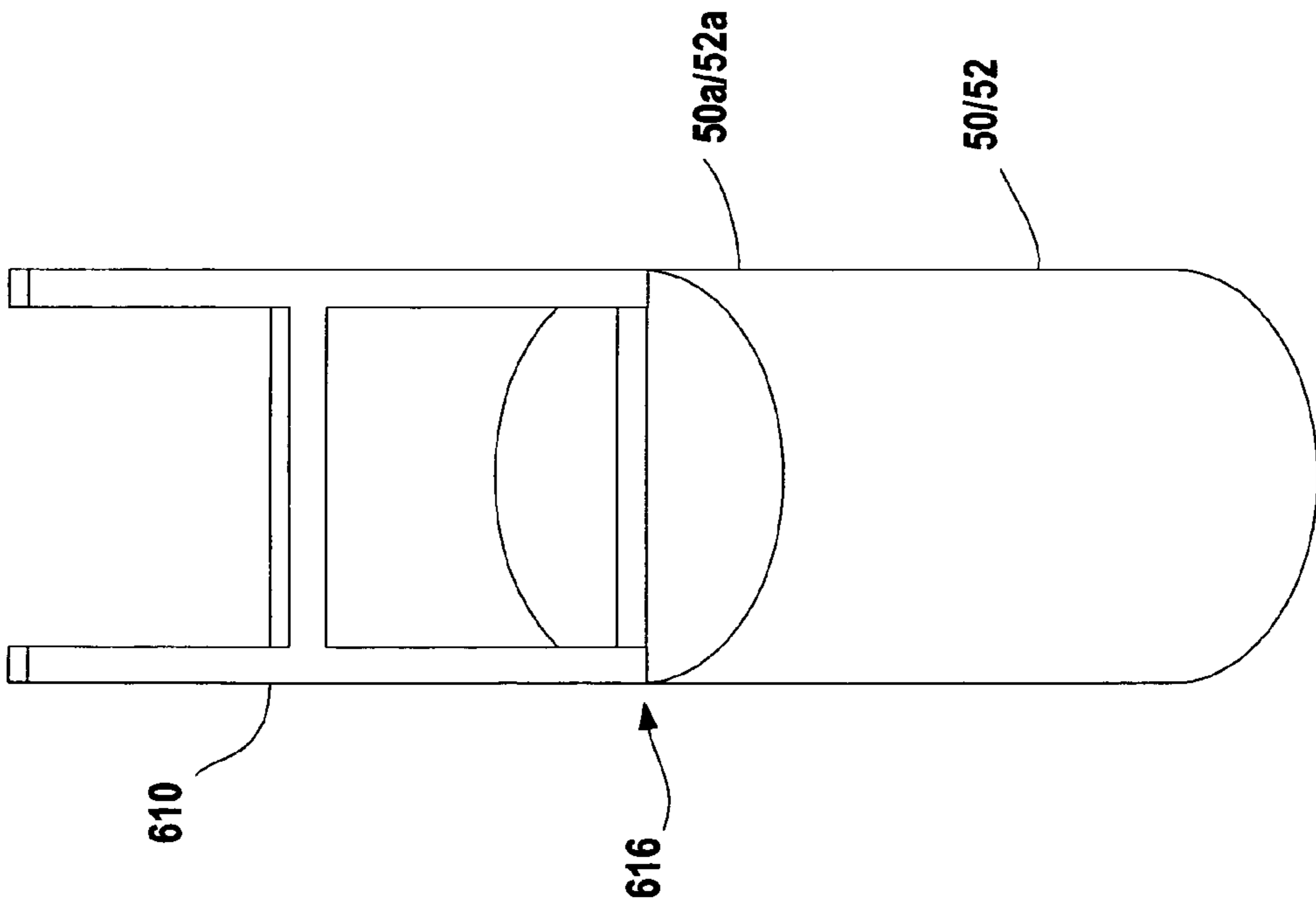

Fig. 17

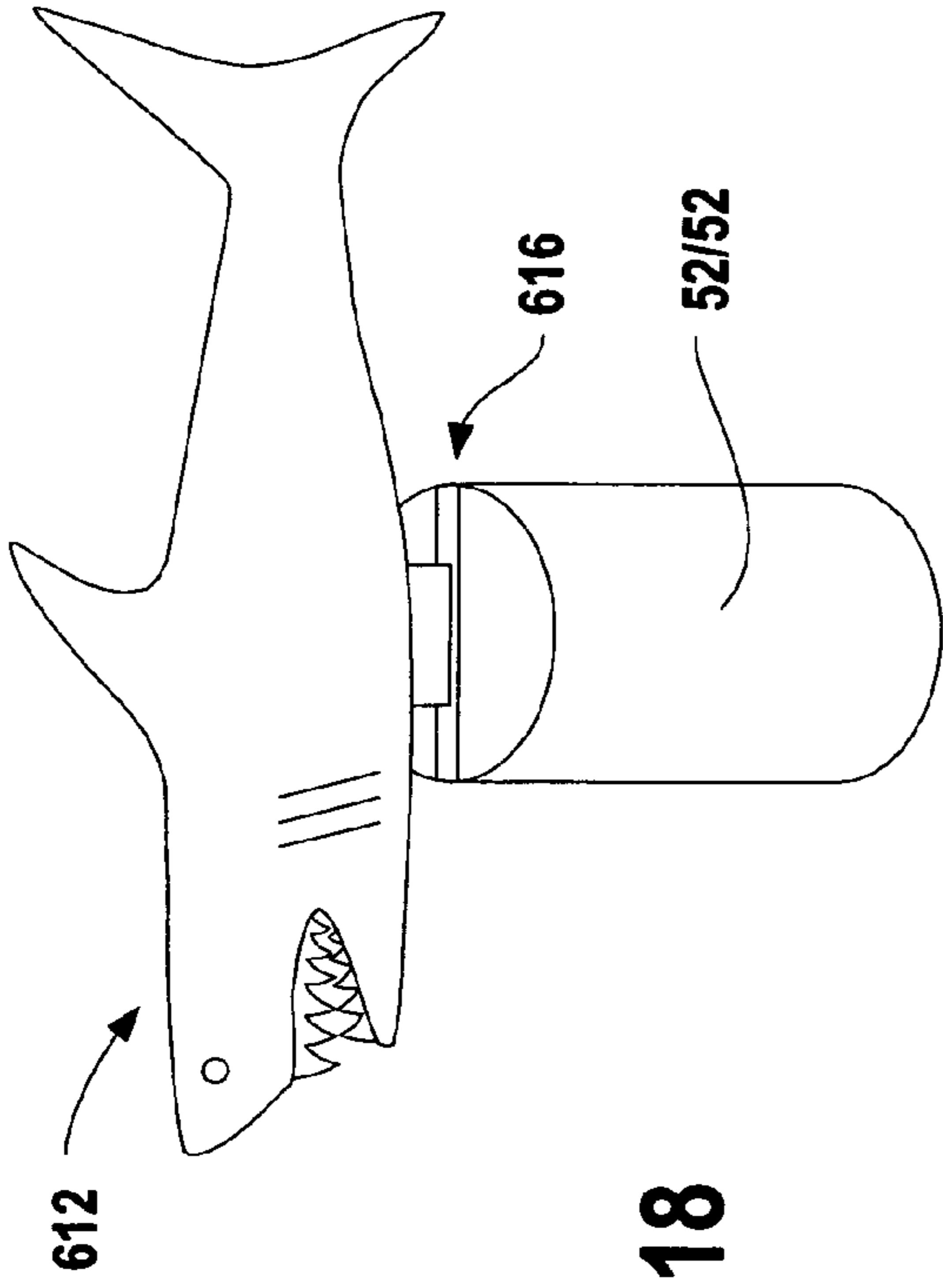

Fig. 18

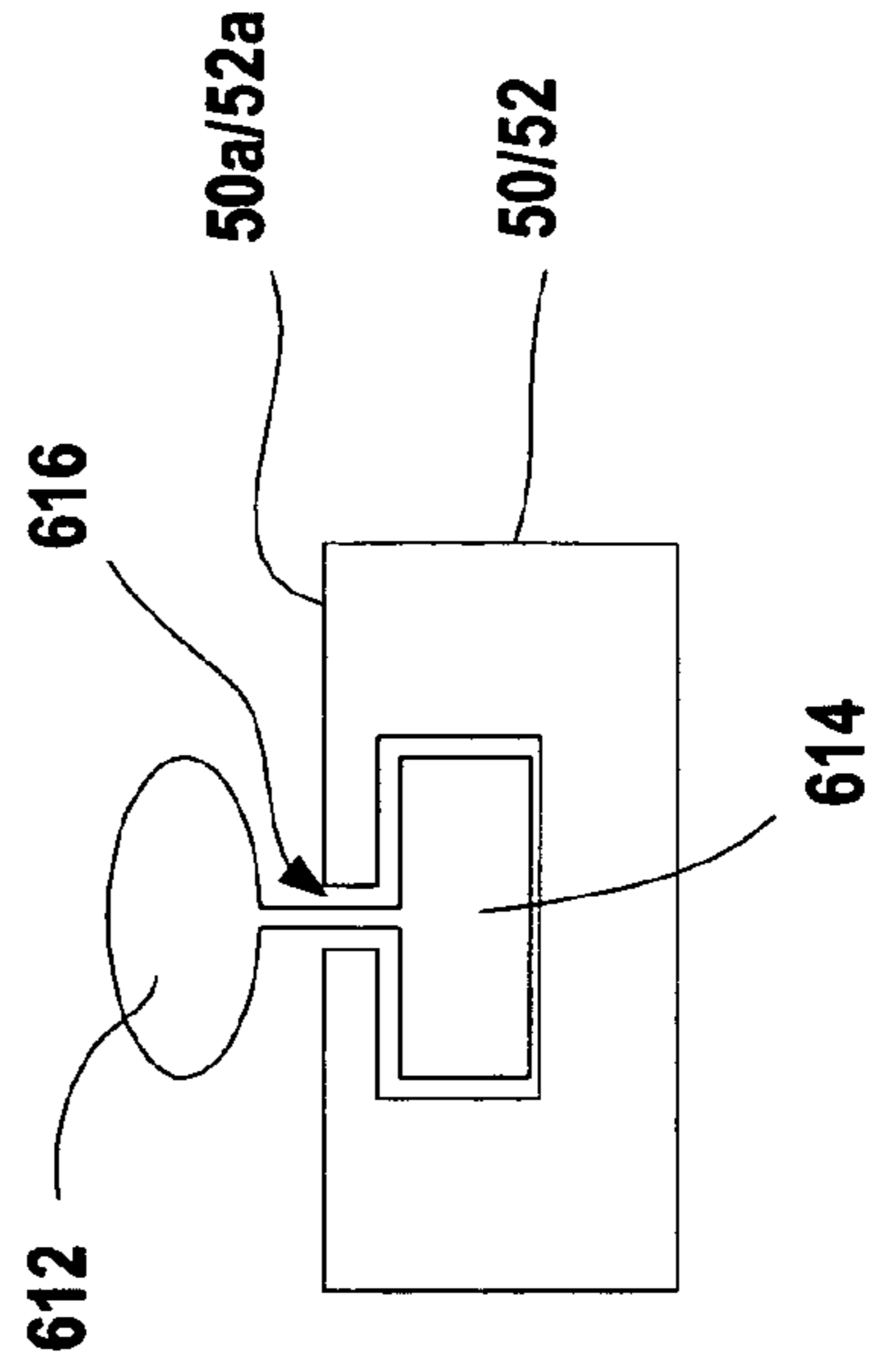

Fig. 18a

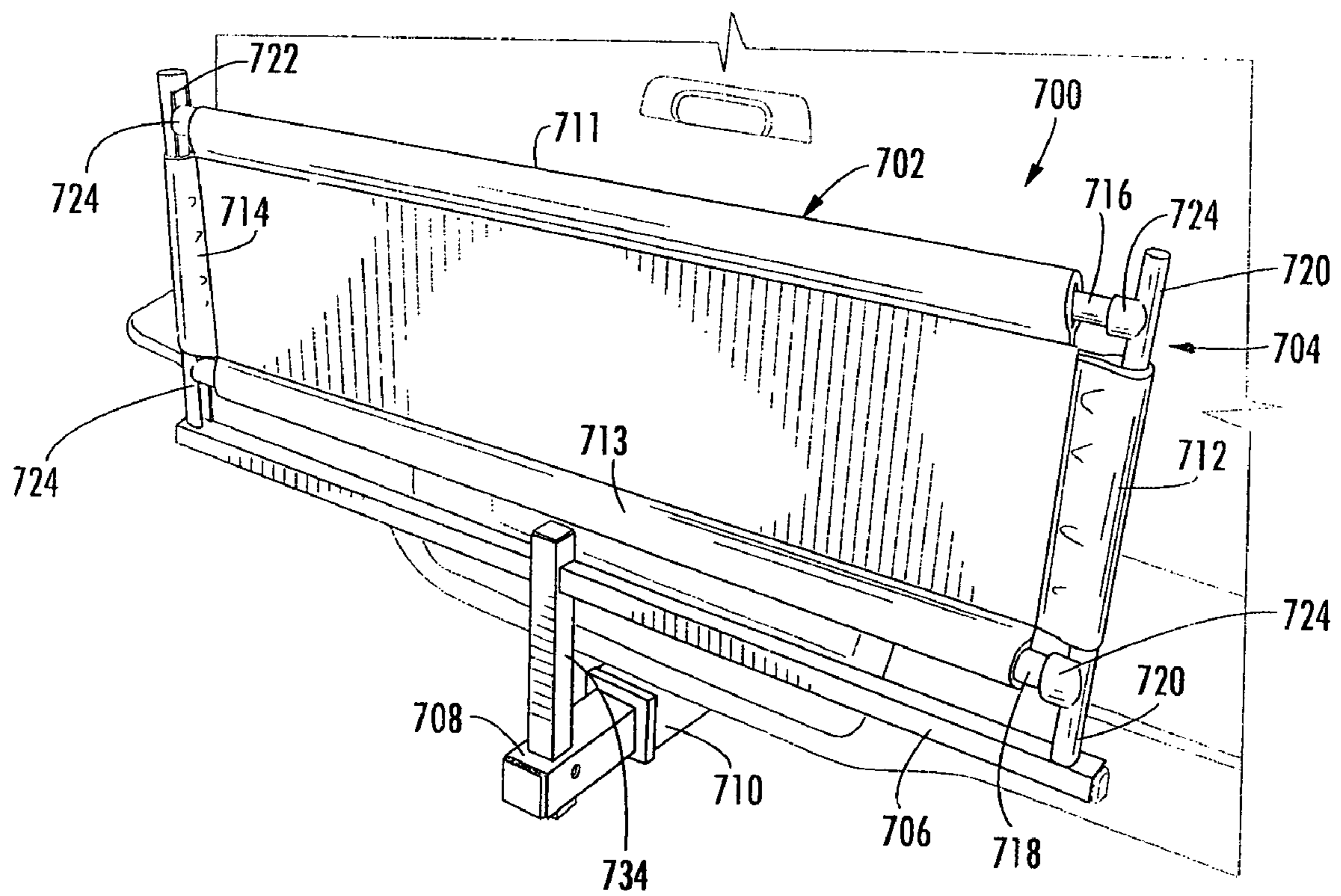

FIG. 19

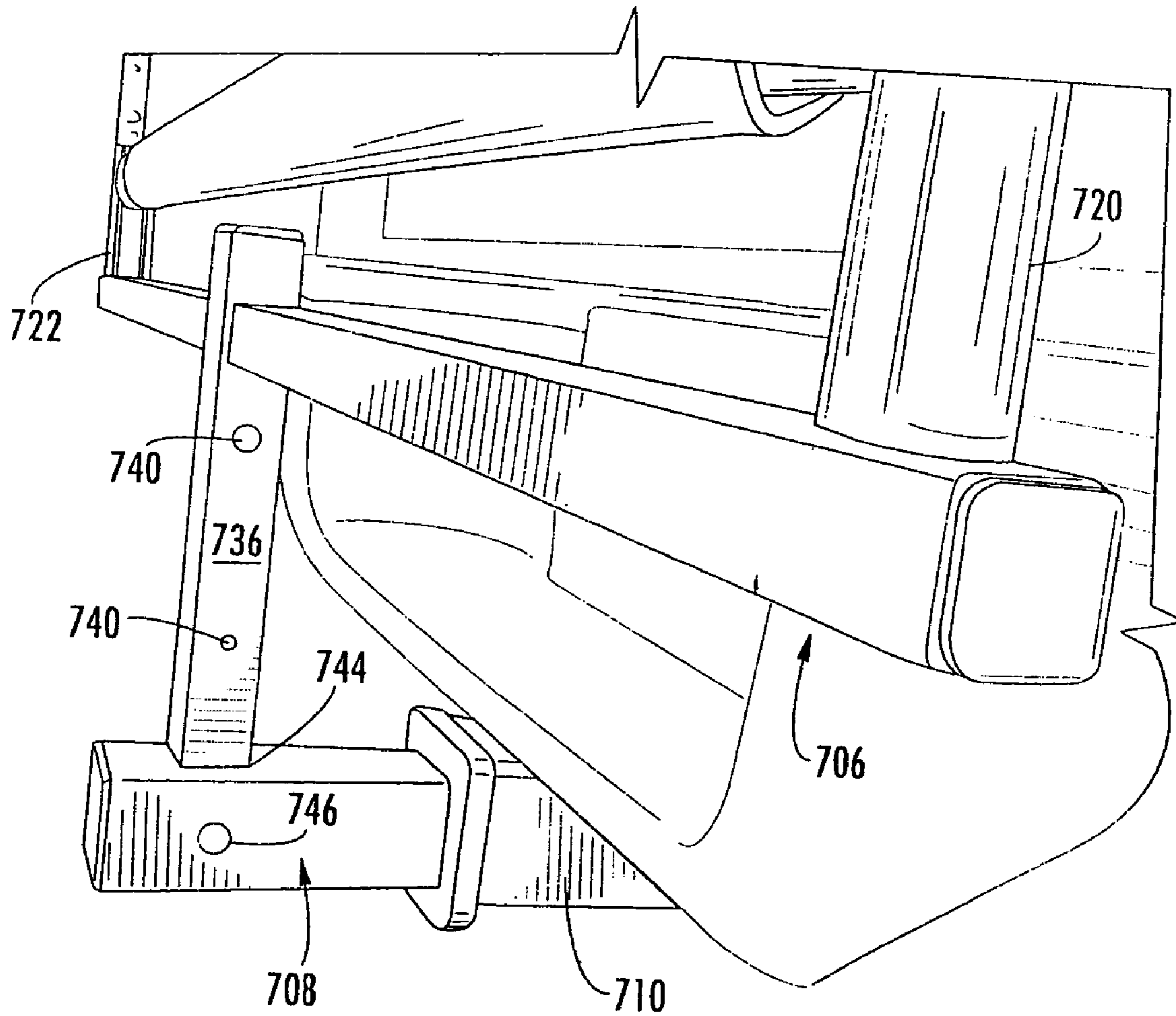

FIG. 20

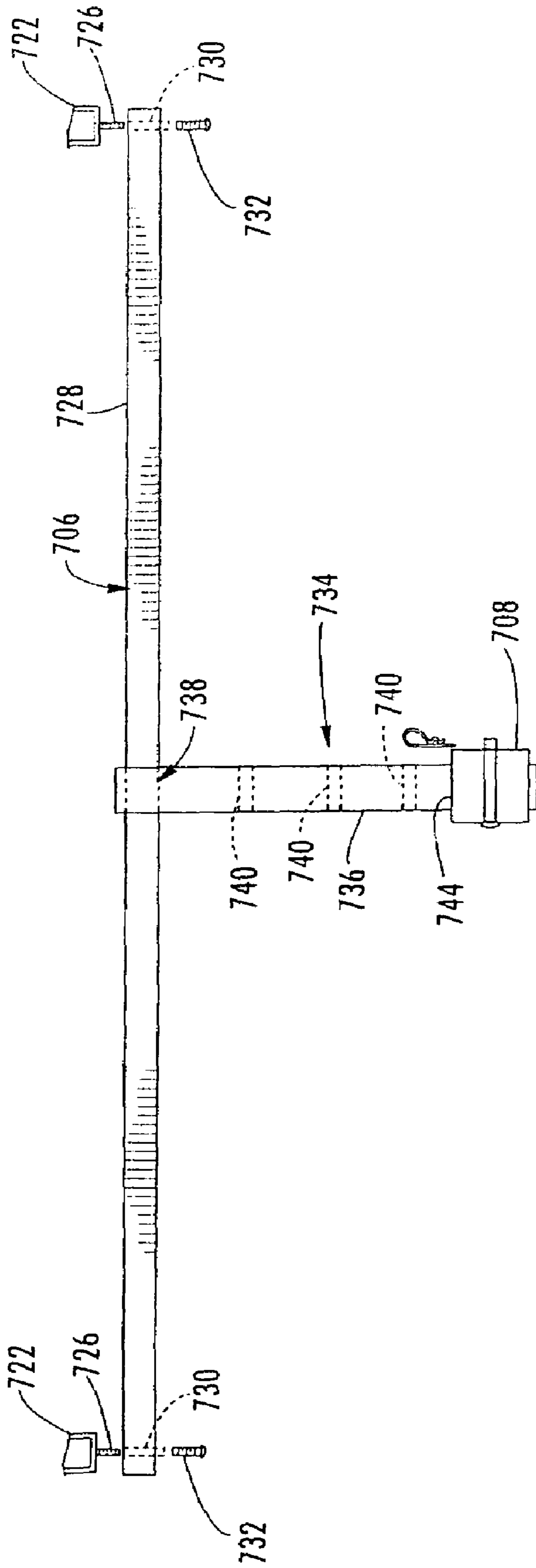

FIG. 21

1

HITCH MOUNTED BANNER DISPLAY SYSTEM

CROSS REFERENCE TO RELATED APPLICATIONS

This application is a continuation-in-part of application Ser. No. 10/616,616 filed Jul. 10, 2003 now U.S. Pat. No. 6,892,486, and entitled BANNER DISPLAY SYSTEM (allowed), which is a continuation of application Ser. No. 09/881,496 filed Jun. 14, 2001, and entitled BANNER DISPLAY SYSTEM, now abandoned.

FIELD OF THE INVENTION

The present invention relates to displays. More particularly, the invention relates to systems mountable to a trailer hitch for displaying banners, signage and the like.

BACKGROUND AND SUMMARY OF THE INVENTION

Various devices for displaying signs and banners are known in the art. However, such devices desire improvement in that they are typically unduly heavy or awkward or difficult to assemble and use. Accordingly, there is a need in the art for an improved system for displaying signs and banners and, particularly signs and banners made of non-rigid sheet materials, and, in particular, to a system that can be mounted to a vehicle via a trailer hitch of the vehicle.

In this regard, the invention relates to a display system for use with a trailer hitch. In a preferred embodiment, the display system includes a banner and a frame to support the banner. The frame includes a pair of vertical frame members and a frame support is provided to support the frame. The frame support includes a first elongate member positionable adjacent the frame and configured for connection of the vertical frame members to the frame support, and a second elongate member extending from the first elongate member. A support connector is provided having a first portion thereof configured to receive the second elongate member of the frame support and a second portion thereof configured to be connectable with the trailer hitch.

BRIEF DESCRIPTION OF THE DRAWINGS

Further aspects of the invention will become apparent by reference to the detailed description of preferred embodiments when considered in conjunction with the figures, which are not to scale, wherein like reference number, indicate like elements through several views.

FIG. 1 is a perspective view of a display system in accordance with a preferred embodiment of the invention.

FIG. 2 is an exploded view of the display system of FIG. 1, and FIG. 2a is a front plan view of a blank used to make the banner portion of the display system.

FIG. 3 is an exploded view of a frame assembly used in the display system of FIG. 2.

FIG. 3a is an enlarged view of a base assembly portion of the frame system of FIG. 3.

FIG. 3b is an alternate embodiment of a base assembly.

FIG. 4 is a front plan view of an alternate embodiment of a display system in accordance with the invention.

FIG. 5 is an exploded view of a base assembly portion of the display system of FIG. 4.

FIG. 6 is a side view of the assembled base assembly of FIG. 5 and FIG. 6a is a top plan view thereof.

2

FIGS. 7 and 8 show connection of the base assembly of FIG. 6 to a frame portion of the display system of FIG. 4 in accordance with preferred embodiments of the invention.

FIGS. 9, 9a, 10, 10a, 11, and 11a show alternate arrangements of the base systems in accordance with preferred embodiments of the invention.

FIGS. 12, 12a, and 12b show alternate configurations of the display system in accordance with the invention.

FIGS. 13 and 14 an alternate embodiment of a display system in accordance with the invention for cooperation with a tube type trailer hitch.

FIGS. 15 and 16 an alternate embodiment of a display system in accordance with the invention for cooperation with a roof or luggage rack of an automobile.

FIGS. 17, 18, and 18a show incorporation of decorative elements onto frame systems of the display systems of the invention.

FIGS. 19 and 20 are perspective views of an alternate embodiment of a display system in accordance with the invention for cooperation with a trailer hitch.

FIG. 21 is a front plan view of the system of FIGS. 19 and 20.

DETAILED DESCRIPTION

FIGS. 1–3b

With initial reference to FIGS. 1, 1a, 2 and 2a, the invention relates to a display system 10 that is particularly suitable for displaying signs and banners on surfaces, such as on car and truck roofs as well as other forms of transportation while traveling at relatively low speeds, e.g., preferably less than about 40 miles per hour. The display system 10 preferably includes a banner 12, a frame system 14 to support the banner member 12, and a mounting system 16 for mounting the display system onto a surface, such as the roof of an automobile 18.

The banner 12 is preferably substantially rectangular or square in configuration and made of a flexible, non-rigid sheet material 20 such as a solid or mesh-type vinyl or cloth material. With reference to FIG. 2a, the sheet material 20 is preferably provided as a one-piece blank 22 including a front surface 24 and an opposite back surface 26, preferably having indicia or logo 28 located on one or both of the surfaces 24 and 26 (FIG. 1). The indicia 28 is preferably applied to the banner 12 as by screen printing or the like.

The blank 22 also preferably includes end portions 30 and 32, and side portions 34 and 36. The blank 22 may preferably be made into the banner 12 as by folding each of the portions 30, 32, 34 and 36 about itself and securing free edges 30a, 32a, 34a, and 36a of each of the portions 30–36 to the material 20. The free edges may be secured to the material 20 as by stitches, hook and loop material or the like, at respective locations corresponding to that represented by dashed lines 38, so as to form sleeves 40, 42, 44 and 46. The resulting banner 12 may be of virtually any size, but preferably has a length of from about 4 to about 12 feet and a width of from about 1 to about 4 feet, for use on with an automobile. For other uses, such as for displaying a banner on the top of a computer monitor, the banner preferably has a length of from about 8 to about 14 inches and a width of from about 1 to about 4 inches.

With reference to FIGS. 2 and 3, the frame system 14 preferably includes elongate frame members 50, 52, 54 and 56, preferably made of a wood or a plastic material. The members 50–56 are preferably round or square or X-shaped in cross-section. The frame member 50 has opposite ends

50a and **50b**. Likewise, the other frame members **52–56** have opposite ends designated with the suffixes a and b. The member **50** preferably has apertures **50c** and **50d** adjacent the ends **50a** and **50b** configured for receiving the ends **56b** and **54b** of the members **56** and **54**, respectively. Likewise, the member **52** preferably has apertures **52c** and **52d** adjacent the ends **52a** and **52b** and configured for receiving the ends **56a** and **54a** of the members **56** and **54**, respectively.

The sleeves **40–46** of the banner **12** are configured for slidably receiving the members **50–56**, respectively. Accordingly, the members **50–56** are initially received within the sleeves **40–46** and the frame system **14** assembled by placing and securing the ends of the members **54** and **56** in the apertures **50c**, **50d**, **52c**, and **52d**. Securement is preferably achieved as by friction fit or adhesive.

The ends **50b** and **52b** of the members **50** and **52** are configured for connection with components of the mounting system **16**. In this regard, and with reference to FIGS. **3**, **3a** and **3b**, each mounting system **16** preferably includes a suction cup **60**, a bolt **62** and a connector **64**.

Each suction cup **60** has a force cup **66** opposite a blind bore **68**. Each bolt **62** has a head **70** and a threaded shaft **72** extending from the head **70**. The bore **68** is configured for receiving and frictionally retaining the head **70** of the bolt. Additional securement of the head **70** within the bore **68** may be achieved as by adhesive.

Each connector **64** is preferably cylindrical, having fine, machine treads **74** on the interior sidewall thereof and wood type threads **76** on the exterior surface thereof. A preferred connector is a double-threaded insert available under the trade name HELI-COIL from Heli-Coil Corporation of Danbury, Conn.

A notch **78** is provided on end **80** of the connector **64** for receiving a tool, such as a screwdriver, for turning the connector for threading opposite end **82** of the connector into a threaded bore **84** defined at the ends **50b** and **52b** of the members **50** and **52** and preferably extending substantially along the center line of the members **50** and **52**. As will be appreciated, each bore **84** is preferably configured for threadably receiving the threads **76** of the connector **64**. Likewise, the threads **74** are configured for receiving the threaded shaft **72** of the bolt **62**.

With reference to FIG. **3b**, in an alternate embodiment, and in the case of molded plastic members **50** and **52**, the mounting system **16** may include only the cup **60** and bolt **62**, with the end **50b** of the member (or the end **52b** of the member **52**) molded around the threaded shaft **72** during manufacture of the members **50** and **52**.

FIGS. 4–8

Turning now to FIG. **4**, there is shown an alternate embodiment of a display system **110** having a banner **112**, a frame system **114** to support the banner member **112**, and a mounting system **116** for mounting the display system onto a surface, such as the roof of an automobile. The banner **112** and frame system **116** are preferably substantially identical to the previously described banner **12** and frame system **14**.

With reference to FIGS. **5** and **6**, each mounting system **116** includes a cup portion **118**, a magnet **120** and a bolt **122**.

The cup **118** is preferably either of a thin metal material, such as tin, or of molded plastic construction. The cup **118** preferably includes a substantially circular and continuous sidewall **124** and a substantially circular top **126** adjacent the sidewall **124** so as to define a blind bore **128** interior of the sidewall. An aperture **130** preferably extends through a center portion of the top **126**.

The magnet **120** is preferably substantially donut-shaped, having flat upper and lower surfaces **132**, **134**, circular and continuous sidewall **136** and a bore **138** defined at the center of the surfaces **132**, **134** and extending there between. The bolt **122** includes a head **140** and a threaded shaft **142** extending therefrom. The magnet is preferably sized slightly smaller than the bore **128** of the cup.

The aperture **130** of the cup **118** is sized to permit passage of the threaded shaft **142**, but not the head **140**. The bore **138** is sized to receive the head **140** as well as the threaded shaft **142**.

With reference to FIG. **6**. The mounting system **116** may be assembled by coating the interior of the bore **128** with an epoxy material **144** and then placing the magnet **120** within the bore **128** of the cup **118** so that the aperture **130** and the bore **138** are concentric. As noted above, the magnet **120** is slightly smaller in dimension than the bore **128**. Thus, a void area **146** exists that may be occupied by the epoxy **144**. The bolt **120** is then passed through the bore **138** and the aperture **130** and an additional amount of the epoxy **144** added to fill the bore **138** and to substantially encase the exterior of the cup **118** and the surface **134** of the magnet. The epoxy is then allowed to cure or set. As will be appreciated, the epoxy retains the components of the system **116** from relative movement with respect to one another and further provides an external coating that is generally suitable for placing on a painted metal body, such as an automobile roof, without scratching it.

Turning to FIGS. **7** and **8**, the end **50b** of the member **50** (and the end **52b** of the member **52**) may be attached to the mounting system **116** in the same manner as described previously for the end **50b** of the member **50** in connection with the mounting assembly **16** and with reference to FIGS. **3a** and **3b**. That is, FIG. **7** shows use of a connector **80** and FIG. **8** shows direct molding of the member **50** onto the threaded shaft **142**.

FIGS. 9–11a

With reference now to FIGS. **9–11a**, there are shown additional orientations of the mounting systems **16** and **116**. For example, as seen in FIGS. **9** and **9a**, the mounting may be accomplished by each side of the display system **10** being supported by a plurality of the mounting systems **16** or **116** joined together as by a metal or rigid plastic tripod **150**. The tripod **150** includes apertures **152** for receiving the threaded bolts of the systems **16** or **116** (or combinations thereof) and may be secured thereto as by a nut threaded onto the bolt of the system **16** or **116**. Likewise, the center of the tripod has a threaded bolt **154** secured thereto and extending upwardly to cooperate with the ends of the members **50** and **52** in the manners previously described in connection with the threaded bolts of the systems **16** and **116**. Similarly, as seen in FIGS. **10–11a**, other configurations of systems **16/116** may be utilized as by joining the systems **16/116** with straps **156** and **158**. Strap **156** has three apertures **160** for receiving the bolts of the systems **16/116**, with the bolt of the system **16/116** in the center position cooperating with the member **50** or **52**. Strap **158** has apertures **162** at the ends thereof for cooperating with the bolts of the systems **16/116**. A center aperture **164** receives an additional bolt for cooperating with the member **50** or **52**.

FIGS. 12–12b

Turning now to FIG. **12**, there is shown an alternate embodiment of a display system **210** having banner members **212**, **214**, and **216**, a frame system **218** to support banner members **212–216**, and a mounting system **220** for mounting the display system on a surface, such as the roof

of an automobile. Each of the banner members 212–216 is preferably substantially identical to the previously described banner 12, except that only one end of each of the banner members is configured to have a sleeve 215 for receiving a frame member. The other end of the banner member is attached, as by stitches 217, to the adjacent sleeve 215 (FIG. 12a). Mounting system 220 is preferably substantially identical to either previously described mounting systems 16 or 116.

Frame system 218 preferably includes elongate frame members 222, 224, and 226 which are substantially identical to frame members 50 and 52 of frame system 14. Frame system 218 also includes elongate frame members 228, 230, 232, 234, 236, and 238 which are substantially identical to frame members 54 and 56 of frame system 14.

Now turning to FIG. 12b, there is shown an alternate embodiment of a display system 310 having banner member 312, frame member 314 to support banner 312 and mounting system 316 for mounting the display system on a surface, such as a fender of an automobile. Frame member 314 is preferably substantially identical to frame member 52 of frame system 14. Mounting system 316 is preferably substantially identical to either previously described mounting systems 16 or 116.

Banner member 312 is preferably substantially identical to banner member 12 in configuration and construction. However, banner member 312 includes only one side configured with a sleeve 313 for slidably receiving frame member 314 in the same manner as previously described for banner member 12 receiving frame member 52.

FIGS. 13–14

Turning to FIGS. 13 and 14, there is shown an alternate embodiment of a display system 410 including banner member 412 and frame member 414 to support banner 412 and to connect with a receiver-type trailer hitch. Banner member 412 is preferably substantially identical to banner member 312, configured for slidably receiving frame member 414 in the same manner as previously described for banner member 12 receiving frame member 52.

Frame member 414 is preferably made of a wood or plastic material. The frame member 414 is preferably L-shaped with a vertical component 416 and horizontal component 418. An aperture 420 preferably extends through horizontal component 418. Horizontal component 418 is sized slightly smaller in dimension than the receiver tube 422 of the trailer hitch, which has an aperture 424. Trailer hitch 422 is sized to receive horizontal component 418 so that apertures 420 and 424 are concentric. Apertures 420 and 424 are sized to permit passage of the shaft of a hitch pin or bolt.

FIGS. 15–16

Turning to FIGS. 15 and 16, there is shown an alternate embodiment for mounting system 516 for mounting on a luggage rack of an automobile. Mounting system 516 includes cylindrical member 518, members 520 and 522, bolt 524 with head 526 and threaded shaft 528, and a wing nut 530. The members 518–522 are preferably of metal or plastic construction.

Cylindrical member 518 preferably includes a substantially circular and continuous sidewall 532 as to define a bore 534 interior of the sidewall. Bore 534 is sized to receive frame member 52 of the banner system and is closed at end 535. Apertures 536 and 538 preferably extend through a center portion of sidewall 532 so that apertures 536 and 538 are concentric. Aperture 536 is sized slightly larger than aperture 538. The aperture 536 is sized to receive the head

526 as well as the threaded shaft 528. The aperture 538 is sized to permit passage of the threaded shaft 528, but not the head 526. In this regard, it is noted that the bore 534 is sufficiently large to accommodate the frame member and the head of the bolt.

Member 520 is preferably L-shaped with aperture 540 extending through vertical portion 539 of the L-shape. Horizontal portion 541 is preferably perpendicular to the portion 539. Aperture 540 is sized to permit passage of the threaded shaft 528. Member 520 is positioned so that aperture 540 is concentric with aperture 538 of cylindrical member 518.

Member 522 preferably includes a horizontal component 542 and two vertical components 544 and 546. Vertical component 544 extends upwardly from one end of horizontal component 542 and vertical component 546 extends downwardly from the opposite end of horizontal component 542. An aperture 548 preferably extends through the center of vertical component 544. Aperture 548 is sized to permit passage of the threaded shaft 528 as well as contain wing nut 530 received on the threaded shaft. Member 522 is positioned so that aperture 548 is concentric with aperture 540 of L-shaped member 520. Bolt 524 and wing nut 530 are used to connect cylindrical member 518, L-shaped member 520 and member 522.

As will be noted, the assembled system 516 provides a channel 550 for receiving luggage rack member 552. If desired, the channel 550 may be lined with a conformable material, such as foam adhesively secured thereto, for cushioning to avoid scarring of the rack member, to provide a secure fit, and to inhibit rattling and the like.

FIGS. 17–18a

Turning to FIGS. 17 and 18, decorative elements 610 and 612 are shown incorporated onto frame member 50 or 52 of frame assembly 14. Decorative elements, such as elements 610 and 612, can be attached to end 50a or 52a of frame member 50/52. Decorative elements 610 and 612 preferably include a rectangular base 614 which is sized to slide into slot 616 located on 50a/52a of frame member 50/52 for frictional retention and ease of replacement and interchangeability (FIG. 18a). Alternatively, the decorative elements may be otherwise affixed onto the frame as by fasteners or molded directly thereon.

FIGS. 19–21

Turning to FIGS. 19–21, there is shown an alternate embodiment of a display system 700 including a banner 702, a frame 704 to support the banner 702, a frame support 706 to support the frame 704, and a support connector 708 configured to receive the frame support 706 and connect with a receiver-type trailer hitch 710.

The banner 702 is preferably made of a flexible, non-rigid sheet material, and includes a plurality of elongate sleeves 711, 712, 713, and 714. The frame 704 preferably includes a pair of horizontal frame members 716 and 718 and a pair of vertical frame members 720 and 722. The frame members are each slidably positionable within one of the sleeves, with each frame member preferably having a length greater than the length of the sleeve into which it is positionable.

The vertical frame members 720 and 722 each include a pair of spaced apart receivers 724 thereon for receiving ends of the horizontal frame members and thread structure 726 (FIG. 21) provided adjacent an end of each of the vertical frame members. The thread structure 726 is shown as an outwardly extending member having internal threads, but it will be understood that the outwardly extending member may also have external threads. Alternatively, it will be

understood that the thread structure 726 may be thread structure defined internally within the end of the vertical frame members. The banner and frame are assembled by positioning each of the frame members within one of the sleeves and thereafter positioning the opposite ends of each horizontal frame member within one of the receivers of the vertical frame members.

The thus assembled banner and frame may then be installed on the frame support 706. The frame support 706 may preferably be provided as by a square tube 728 having an aperture 730 located adjacent each end thereof and configured for receiving the thread structure 726 of the vertical members 720 and 722. A fastener 732 may then be threaded into or onto the thread structure 726 to secure the vertical members to the square tube 706.

The frame support 706 also preferably includes an extension member 734 between the square tube 728 and the support connector 708. The extension member 734 is preferably provided by a square tube 736 having a square aperture 738 adjacent an upper end thereof for receiving the square tube 706. The square tube 736 is configured for connecting to the support connector 708 and preferably includes a plurality of spaced apart adjustment apertures 740 along the length thereof for permitting adjustment of the vertical height of the banner relative to the hitch by passing a hitch pin or the like through the apertures 740 and corresponding structure of the support connector 708.

The support connector 708 is preferably a square tube configured to be received by the hitch 710 and secured thereto as by a hitch pin passed through corresponding apertures. A square aperture 744 is preferably defined through upper and lower surfaces of the support connector 708 to receive the square tube 736 of the frame support 706. An aperture 746 is preferably defined across the width of the support connector 708 adjacent the aperture 744 for passage of a hitch pin or the like. In this manner, one of the apertures 740 may be aligned with the aperture 746, and a hitch pin or the like passed therethrough to position the banner at a desired height above the receiver 710. Alternatively, it will be understood that the hitch 710 may be a ball-type hitch and the support connector 708 configured to include conventional structure for engaging the ball hitch.

The foregoing description of certain exemplary embodiments of the present invention has been provided for purposes of illustration only. It is understood that numerous modifications or alterations may be made in and to the illustrated embodiments without departing from the spirit and scope of the invention as defined in the following claims.

What is claimed is:

1. A display system for use with a receiver-type trailer hitch having a receiver tube and an aperture through a side thereof for receiving a hitch pin, the display system comprising:

- a banner member made of flexible, non-rigid sheet material and including a plurality of elongated sleeves;
- a frame to support the banner, the frame including a pair of horizontal frame members and a pair of vertical frame members, each slidably positionable within one of the sleeves, with each frame member having a length greater than the length of the sleeve into which it is positionable, the vertical frame members each including a pair of spaced apart receivers thereon for receiving ends of the horizontal frame members and thread

structure provided adjacent an end of each of the vertical frame members, wherein the banner and frame are assembled by positioning each of the frame members within one of the sleeves and thereafter positioning the opposite ends of each horizontal frame members within one of the receivers of the vertical frame members;

a frame support to support the frame and including a first elongate member positionable adjacent the frame and configured for cooperating with the thread structure of the vertical members for connection of the vertical frame members to the frame support, and a second elongate member extending from the first elongate member; and

a support connector having a first portion thereof configured to receive the second elongate member of the frame support and a second portion thereof configured to be connectable with the receiver-type trailer hitch.

2. The display system of claim 1, wherein the second elongate member of the display support is adjustably positionable relative to the first portion of the support connector.

3. The display system of claim 2, wherein the first portion of the support connector is configured to slidingly receive the second elongate member of the display support.

4. The display system of claim 1, wherein the thread structure of the vertical frame members comprises thread structure which extends outwardly from ends of the vertical frame members and the first elongate member of the frame support includes apertures for receiving the thread structure.

5. A display system for use with a trailer hitch, the display system comprising:

a banner member made of flexible, non-rigid sheet material and including a plurality of elongated sleeves;

a frame to support the banner, the frame including a pair of horizontal frame members and a pair of vertical frame members, each slidably positionable within one of the sleeves, with each frame member having a length greater than the length of the sleeve into which it is positionable, the vertical frame members each including a pair of spaced apart receivers thereon for receiving ends of the horizontal frame members and thread structure provided adjacent an end of each of the vertical frame members, wherein the banner and frame are assembled by positioning each of the frame members within one of the sleeves and thereafter positioning the opposite ends of each horizontal frame members within one of the receivers of the vertical frame members;

a frame support to support the frame and including a first elongate member positionable adjacent the frame and configured for cooperating with the thread structure of the vertical members for connection of the vertical frame members to the frame support, and a second elongate member extending from the first elongate member; and

a support connector having a first portion thereof configured to receive the second elongate member of the frame support and a second portion thereof configured to be connectable with the trailer hitch.

6. The display system of claim 5, wherein the second portion of the support connector is configured for being received within a receiver-type trailer hitch.