

US007166035B2

(12) **United States Patent**
Voges et al.

(10) **Patent No.:** **US 7,166,035 B2**
(45) **Date of Patent:** **Jan. 23, 2007**

(54) **SYSTEMS AND METHODS FOR FITTING GOLF EQUIPMENT**

(76) Inventors: **Mitchell Clark Voges**, 237 Randely Ct., Simi Valley, CA (US) 93065;
Daniel Patrick Hollister, 27150 Silver Oak La. # 2031, Santa Clarita, CA (US) 91387

(*) Notice: Subject to any disclaimer, the term of this patent is extended or adjusted under 35 U.S.C. 154(b) by 0 days.

(21) Appl. No.: **10/722,579**

(22) Filed: **Nov. 26, 2003**

(65) **Prior Publication Data**

US 2005/0085311 A1 Apr. 21, 2005

Related U.S. Application Data

(63) Continuation-in-part of application No. 10/053,797, filed on Jan. 18, 2002.

(51) **Int. Cl.**

A63B 57/00 (2006.01)
G01B 7/16 (2006.01)
G01L 1/00 (2006.01)

(52) **U.S. Cl.** **473/222; 473/223; 473/409; 73/767; 73/773; 73/781; 73/791**

(58) **Field of Classification Search** **473/221-223, 473/289, 409; 73/1.37, 1.79, 1.81, 760, 763, 73/767, 773, 781, 791**

See application file for complete search history.

(56) **References Cited**

U.S. PATENT DOCUMENTS

- 1,167,106 A 1/1916 Palmer
- 3,717,857 A * 2/1973 Evans 340/870.13
- 3,945,646 A * 3/1976 Hammond 473/223
- 3,963,236 A * 6/1976 Mann 473/289
- 4,059,270 A * 11/1977 Sayers 473/409
- 4,094,072 A 6/1978 Erb

- 4,214,754 A 7/1980 Zebelean
- 4,432,549 A 2/1984 Zebelean
- 4,885,847 A 12/1989 Korfanta
- 5,004,241 A 4/1991 Antonious
- 5,067,719 A * 11/1991 Mook 473/200
- 5,078,398 A 1/1992 Reed et al.
- 5,133,556 A * 7/1992 Karasavas 473/218
- 5,244,210 A 9/1993 Au
- 5,257,807 A 11/1993 Baumann et al.
- 5,335,909 A 8/1994 Green, Jr.
- 5,429,365 A 7/1995 McKeighen
- 5,447,309 A 9/1995 Vincent
- 5,459,793 A * 10/1995 Naoi et al. 382/165

(Continued)

OTHER PUBLICATIONS

International Search Report for PCT/US06/02390.

Primary Examiner—Stephen Blau

(57) **ABSTRACT**

A golf equipment fitting system that uses advanced technology to not only objectively identify the optimum equipment for the golfer, but to also identify and help correct swing flaws so that the golfer can achieve optimum performance on the golf course. Thus, in one embodiment, golf fitting includes collecting data related to the golfer's swing and determining if the golfer's swing technique should be modified based at least in part on the collected swing data. When it is determined that the golfer's swing technique should be modified, then providing swing instruction to the golfer. When, however, it is determined that the golfer's swing technique is fine, then collecting data related to how the golfer's swing launches a golf ball. Finally, golf equipment, e.g., golf clubs, can be specified based on the collected swing data and launch data.

21 Claims, 15 Drawing Sheets

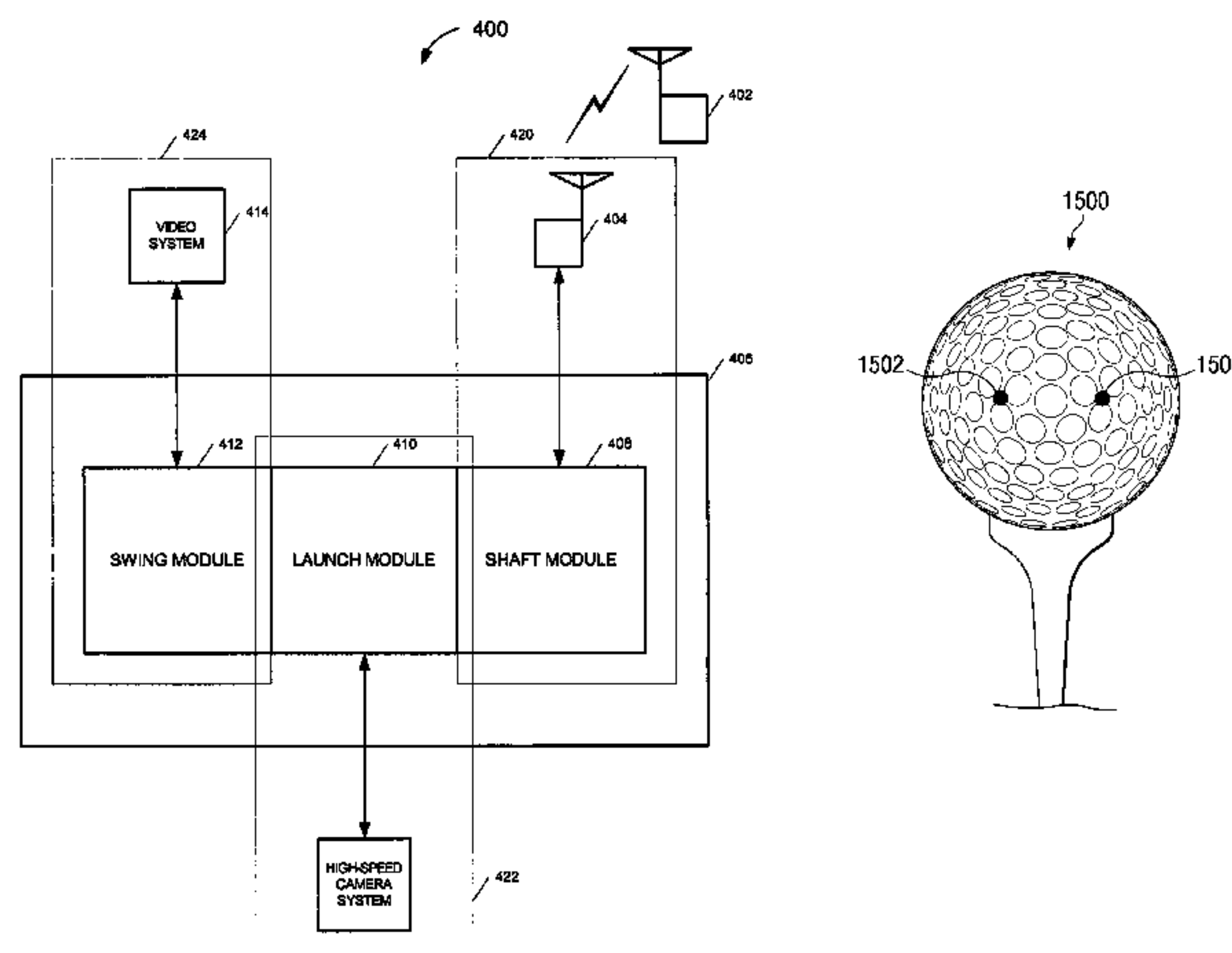

US 7,166,035 B2

Page 2

U.S. PATENT DOCUMENTS

5,478,073	A *	12/1995	Hackman	473/289	6,331,149	B1	12/2001	Mikame et al.	
5,616,832	A *	4/1997	Nauck	73/65.03	6,334,817	B1	1/2002	Ezawa et al.	
5,755,624	A	5/1998	Helmstetter		6,390,934	B1 *	5/2002	Winfield et al.	473/351
5,779,556	A *	7/1998	Cervantes et al.	473/237	6,398,670	B1	6/2002	Engelhardt et al.	
5,792,000	A *	8/1998	Weber et al.	473/223	6,425,832	B2	7/2002	Cackett et al.	
5,821,417	A *	10/1998	Naruo et al.	73/491	6,431,990	B1	8/2002	Manwaring	
5,884,409	A	3/1999	Muldoon		6,488,594	B1	12/2002	Card et al.	
5,916,041	A *	6/1999	Antonious	473/328	6,506,129	B2	1/2003	Chen	
5,984,804	A	11/1999	Berg		6,533,674	B1	3/2003	Gobush	
6,001,495	A	12/1999	Bristow et al.		6,595,128	B2	7/2003	Parks	
6,050,904	A	4/2000	Kuo		6,692,382	B2	2/2004	Adams et al.	
6,213,888	B1 *	4/2001	Kawaguchi et al.	473/223	6,758,759	B2 *	7/2004	Gobush et al.	473/131
6,224,493	B1 *	5/2001	Lee et al.	473/223	6,834,129	B2 *	12/2004	Asakura	382/289
6,273,828	B1	8/2001	Wood et al.		2002/0032076	A1 *	3/2002	Isogawa et al.	473/351
6,290,607	B1	9/2001	Gilbert et al.		2002/0077189	A1 *	6/2002	Tuer et al.	473/151
6,305,063	B1	10/2001	Ashcraft et al.		2003/0008731	A1 *	1/2003	Anderson et al.	473/407
6,306,048	B1	10/2001	McCabe et al.		2005/0079932	A1	4/2005	Voges et al.	

* cited by examiner

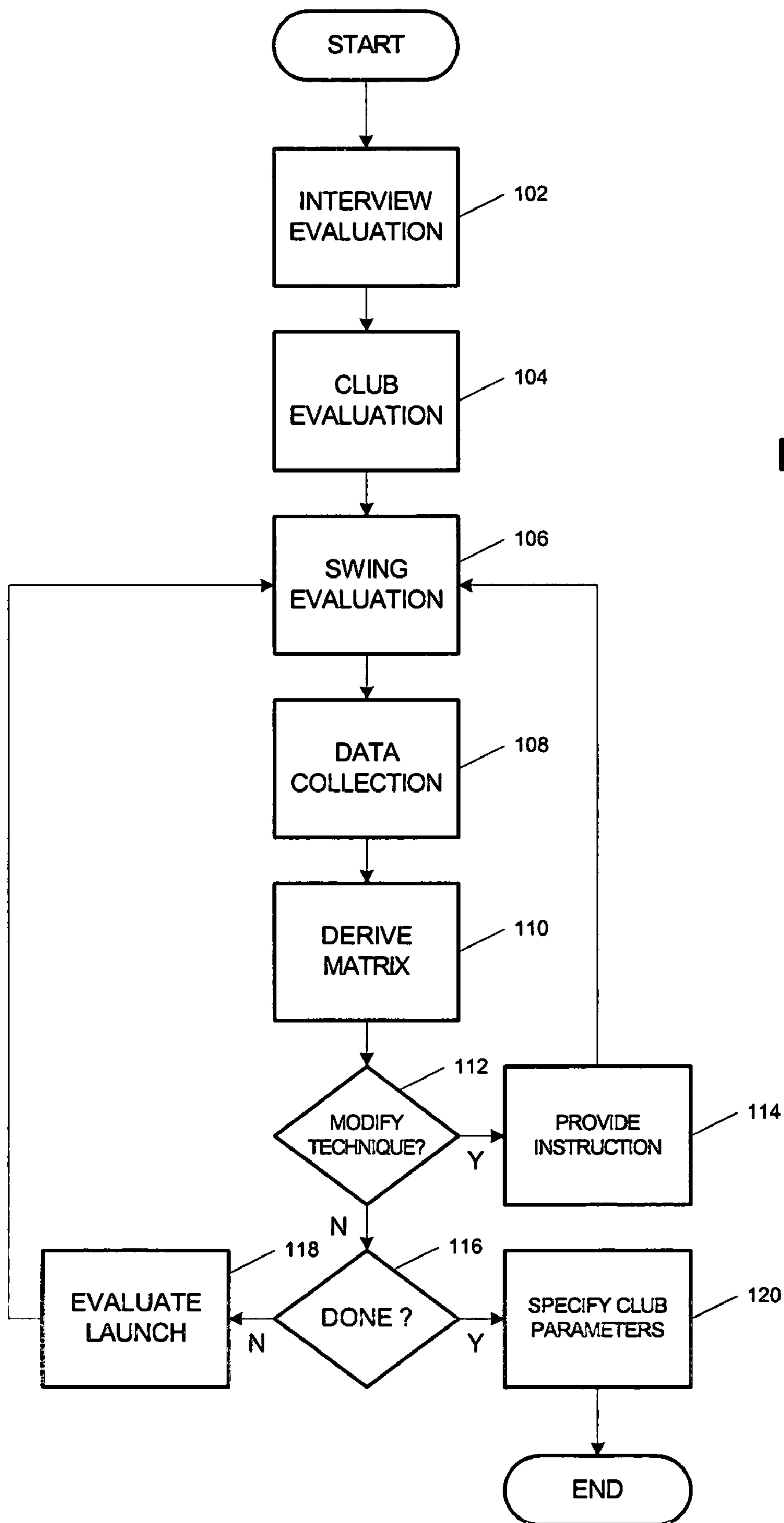

FIG. 1

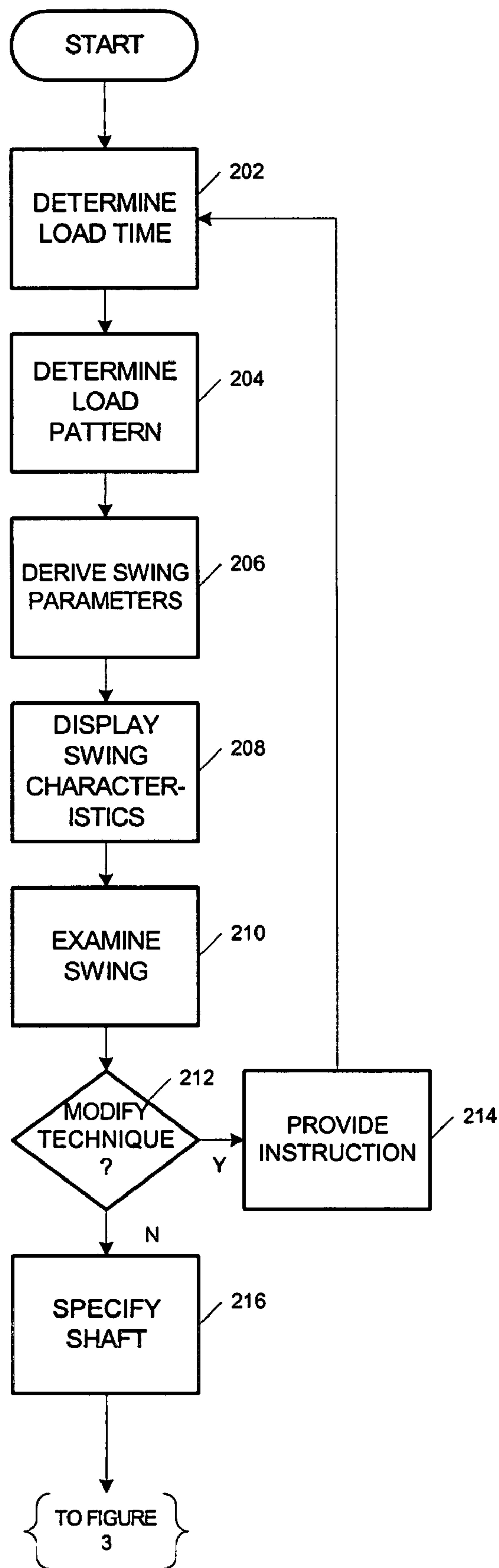
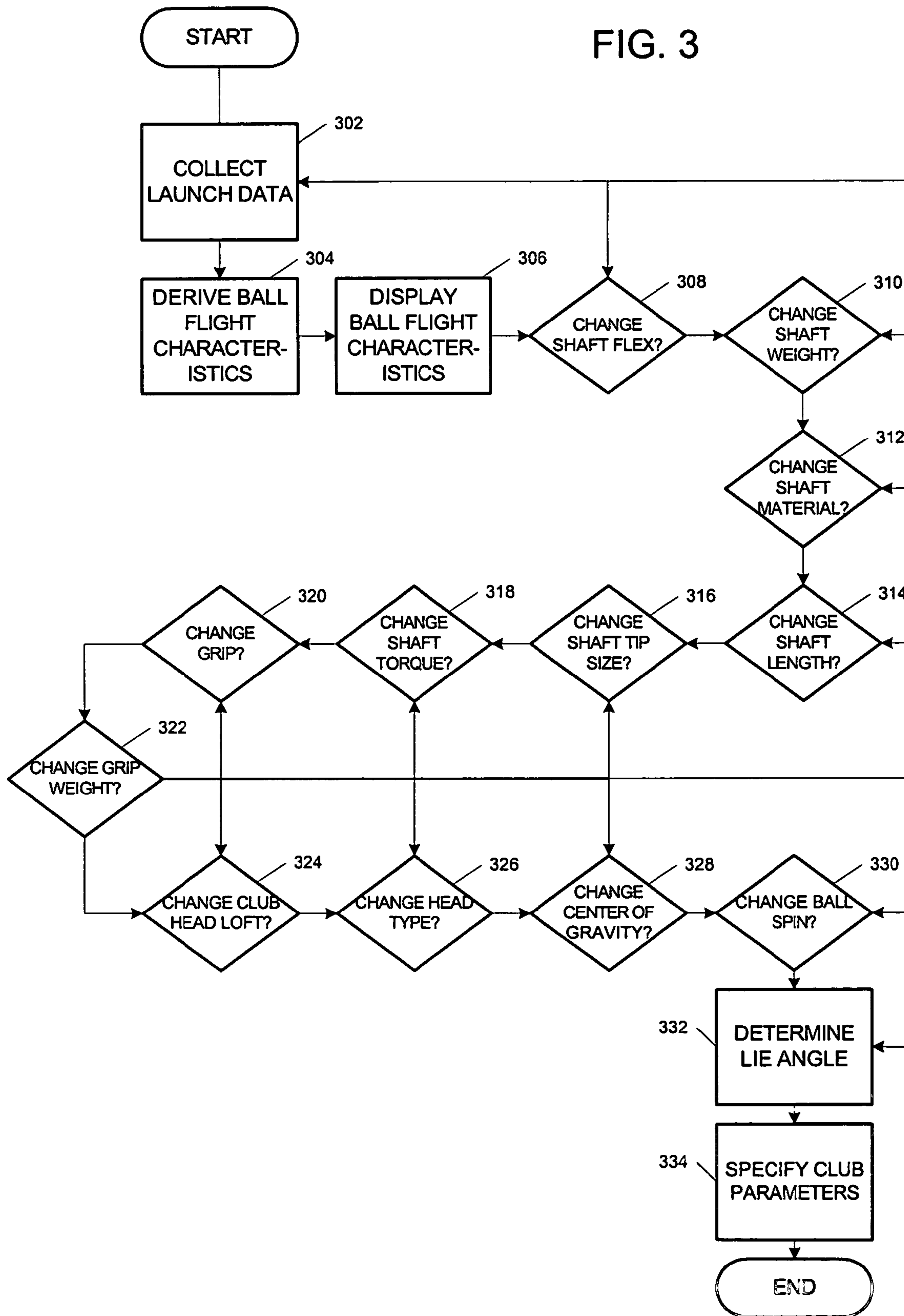

FIG. 2

FIG. 3



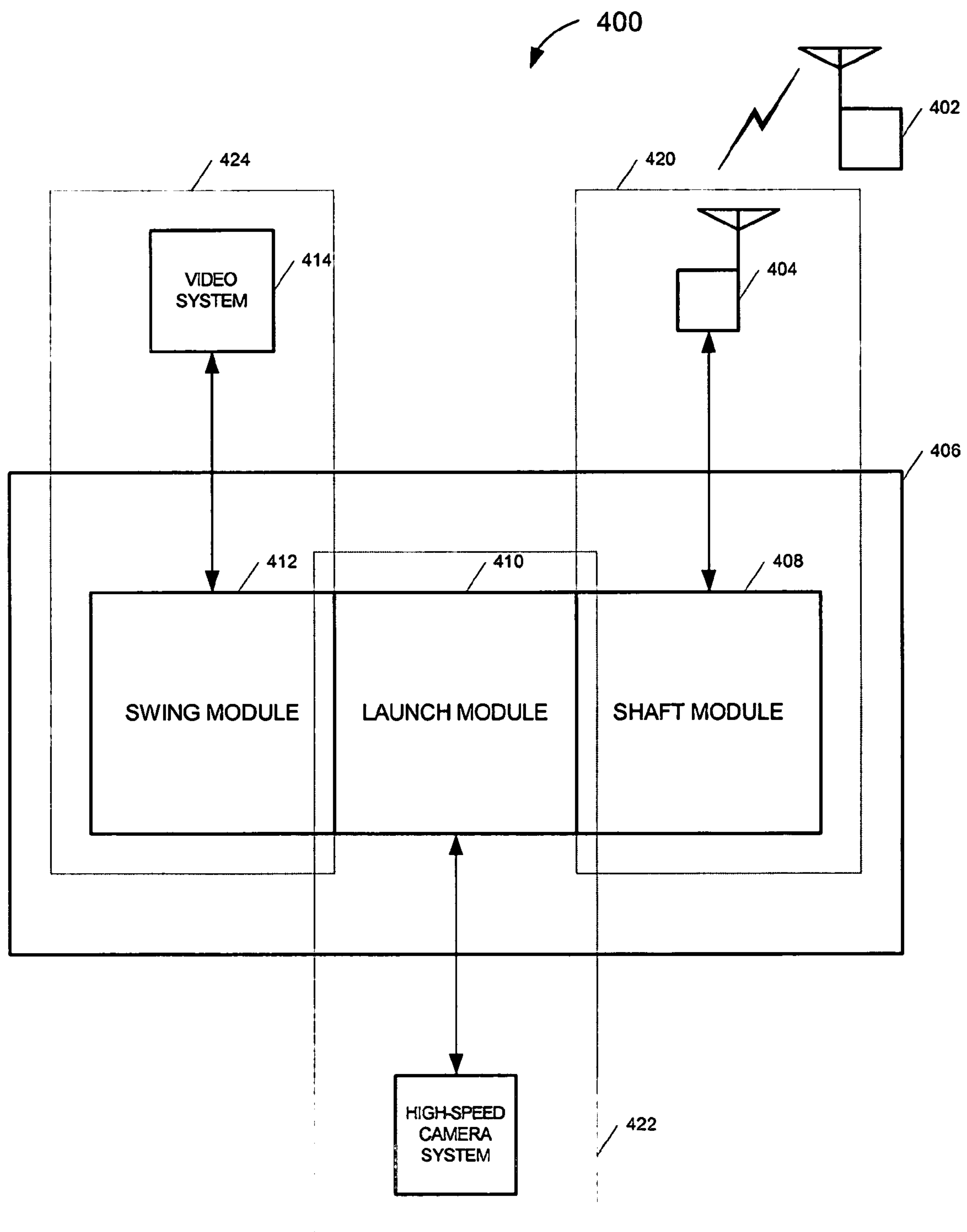
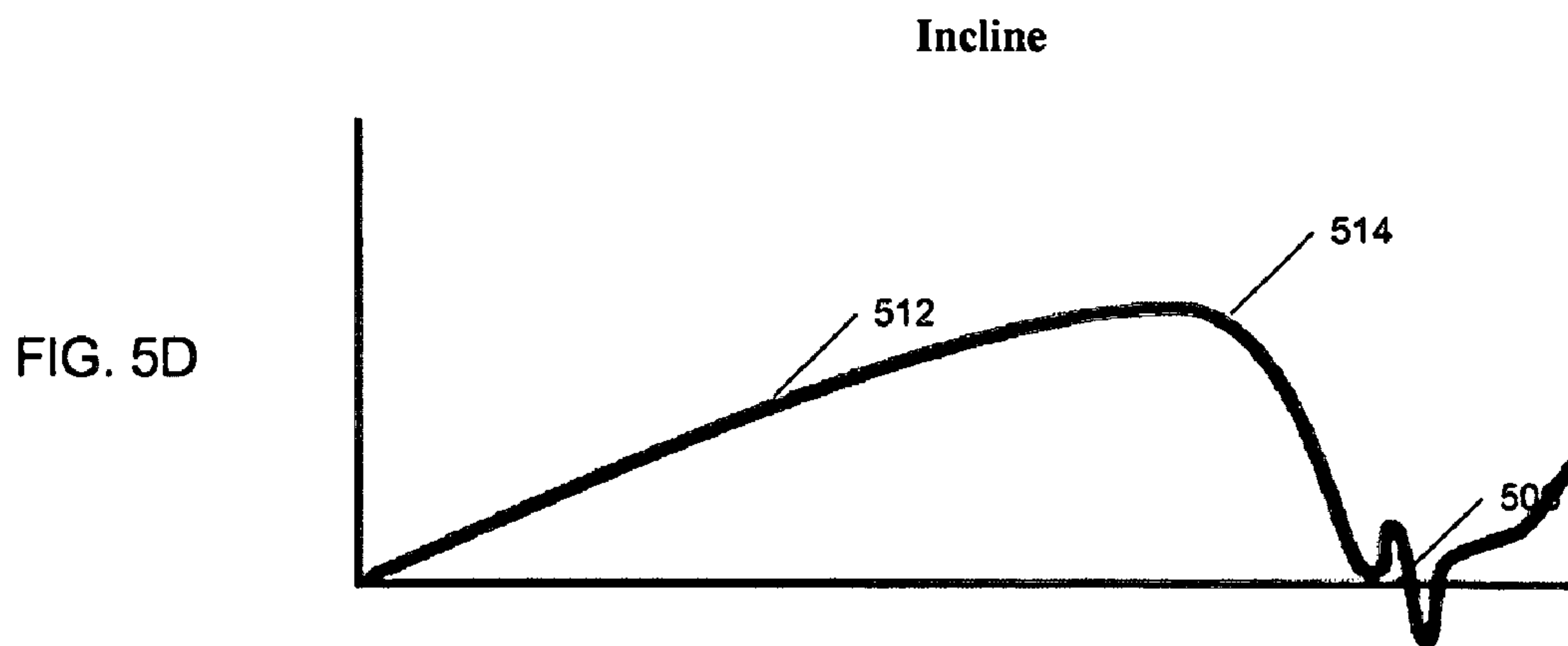
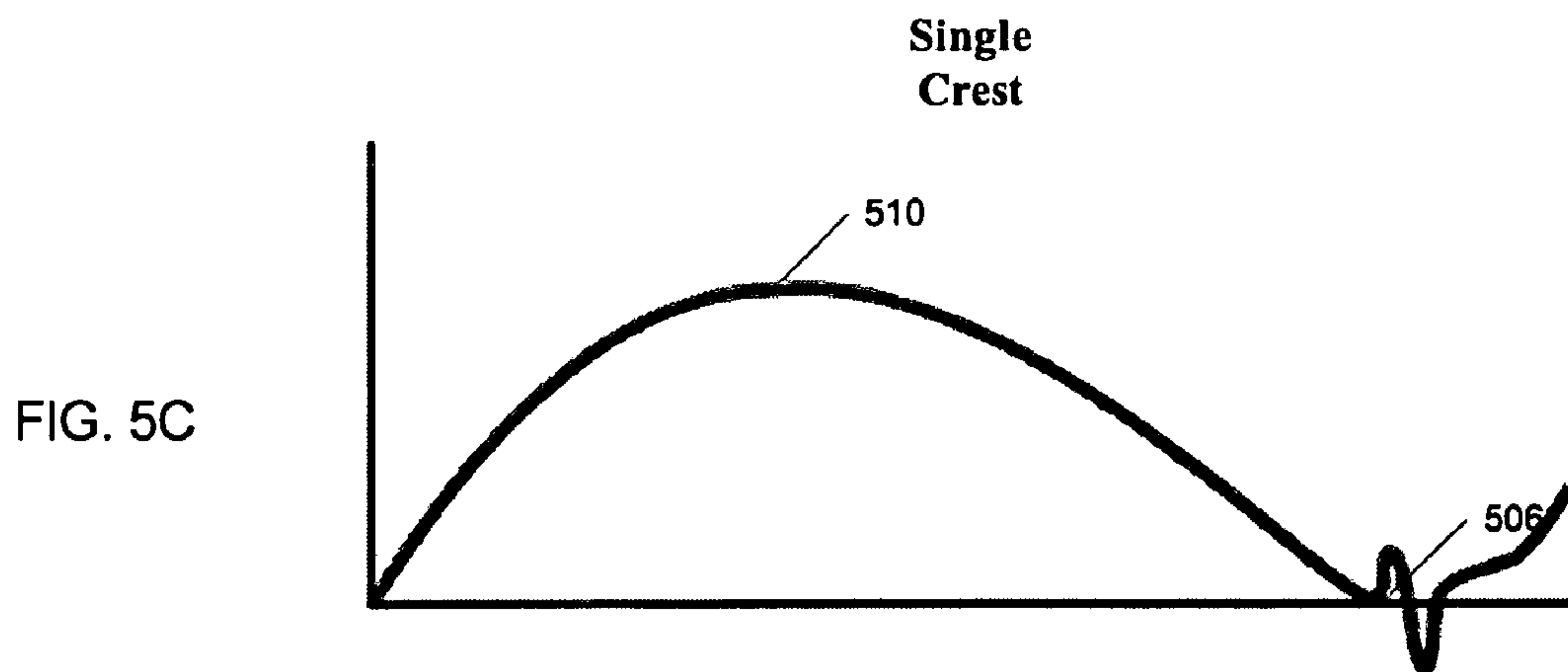
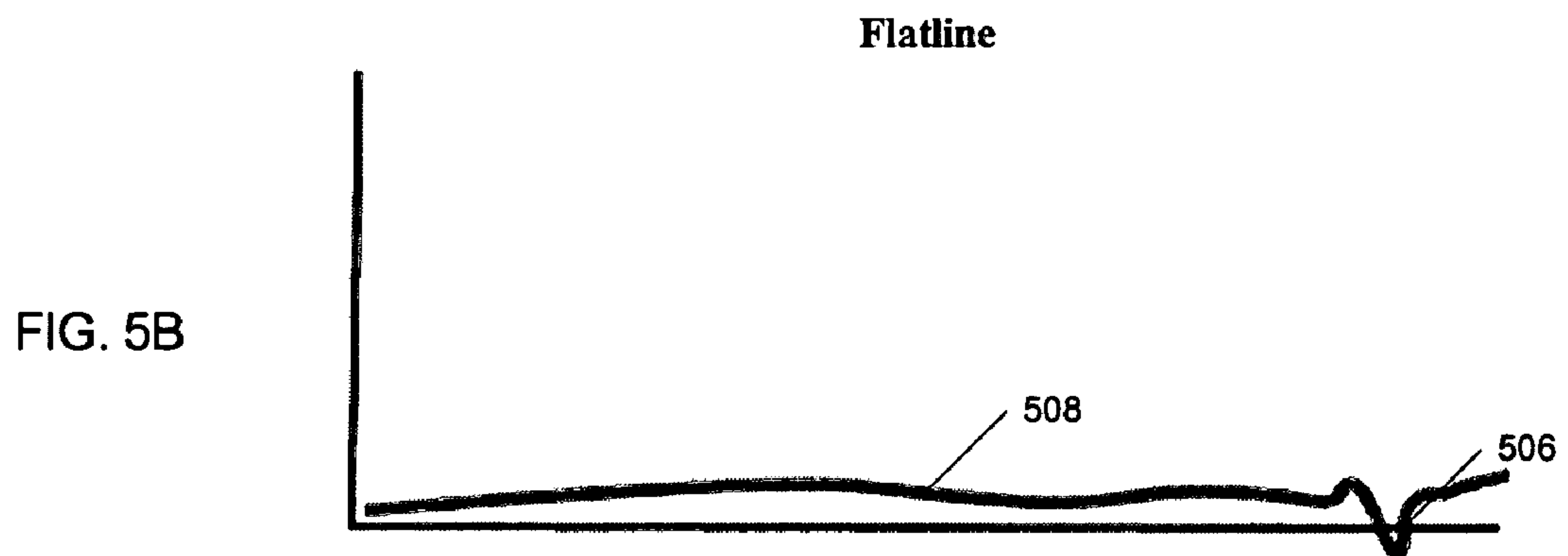
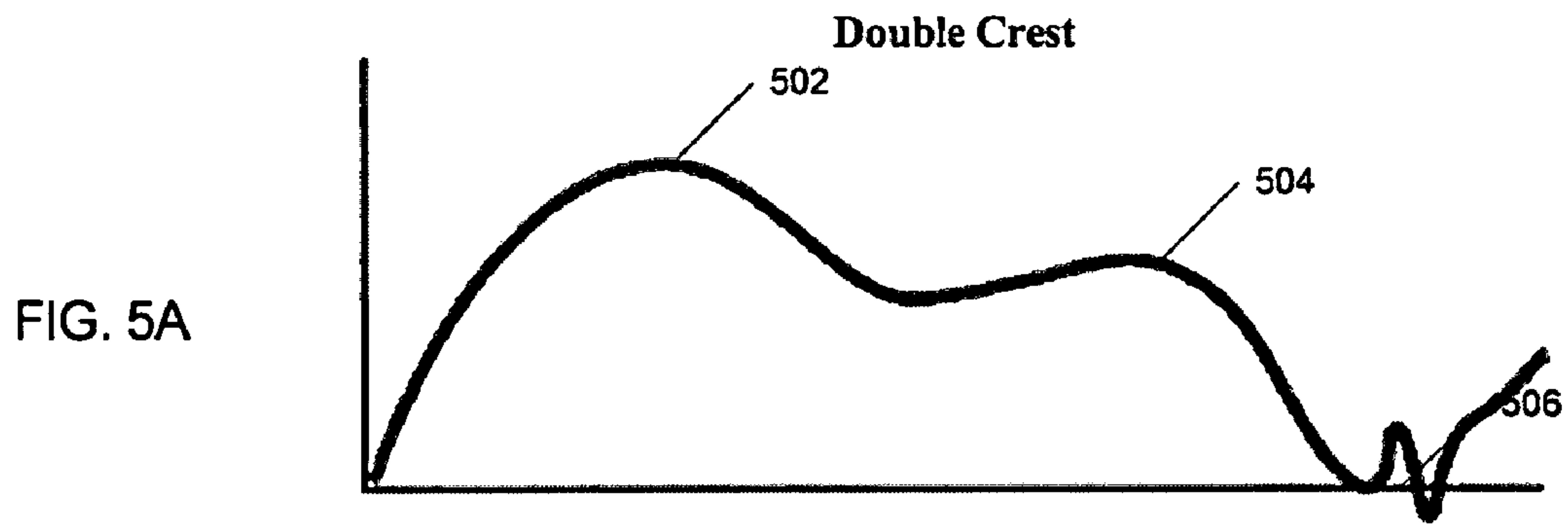

FIG. 4



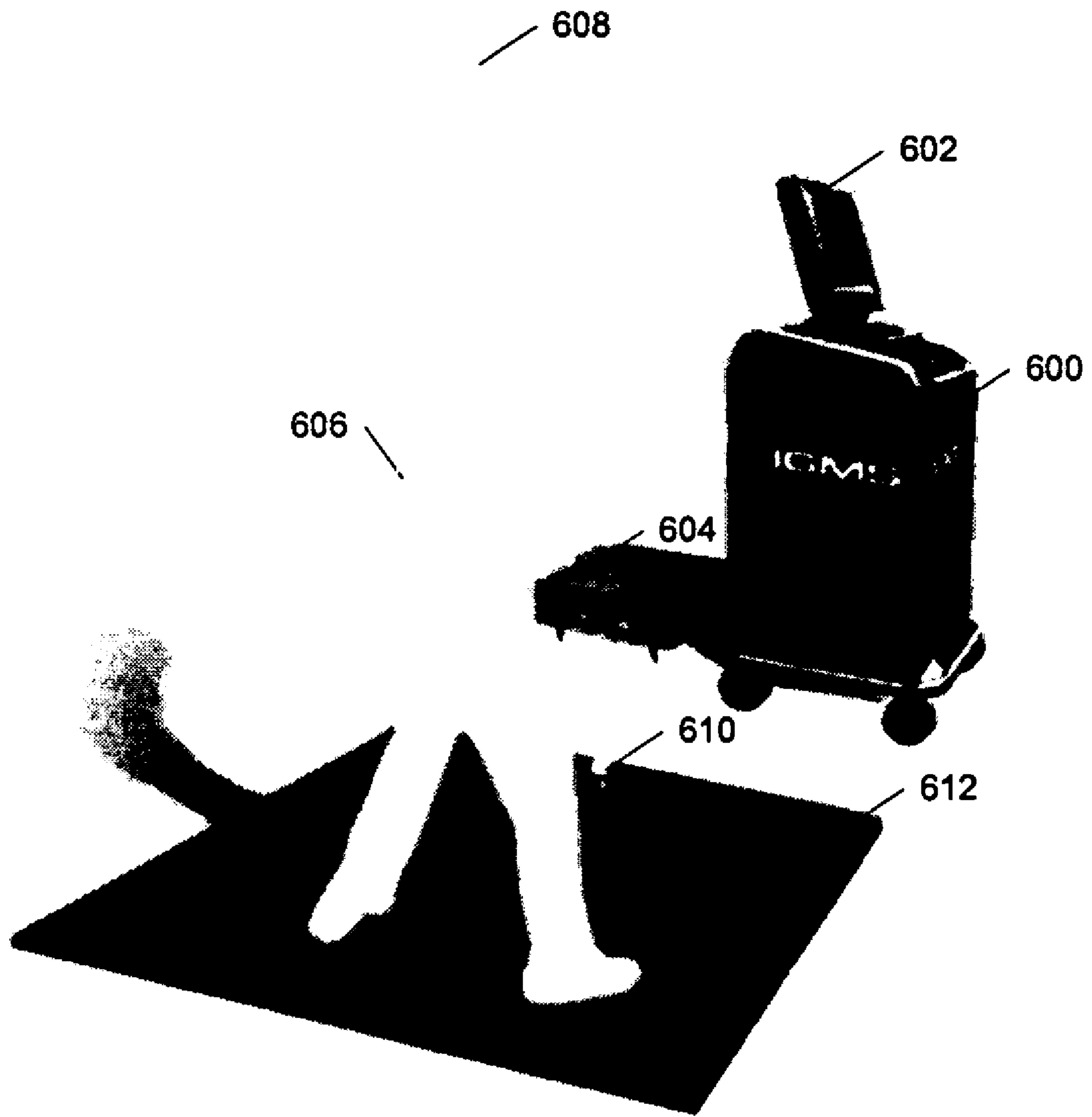

FIG. 6

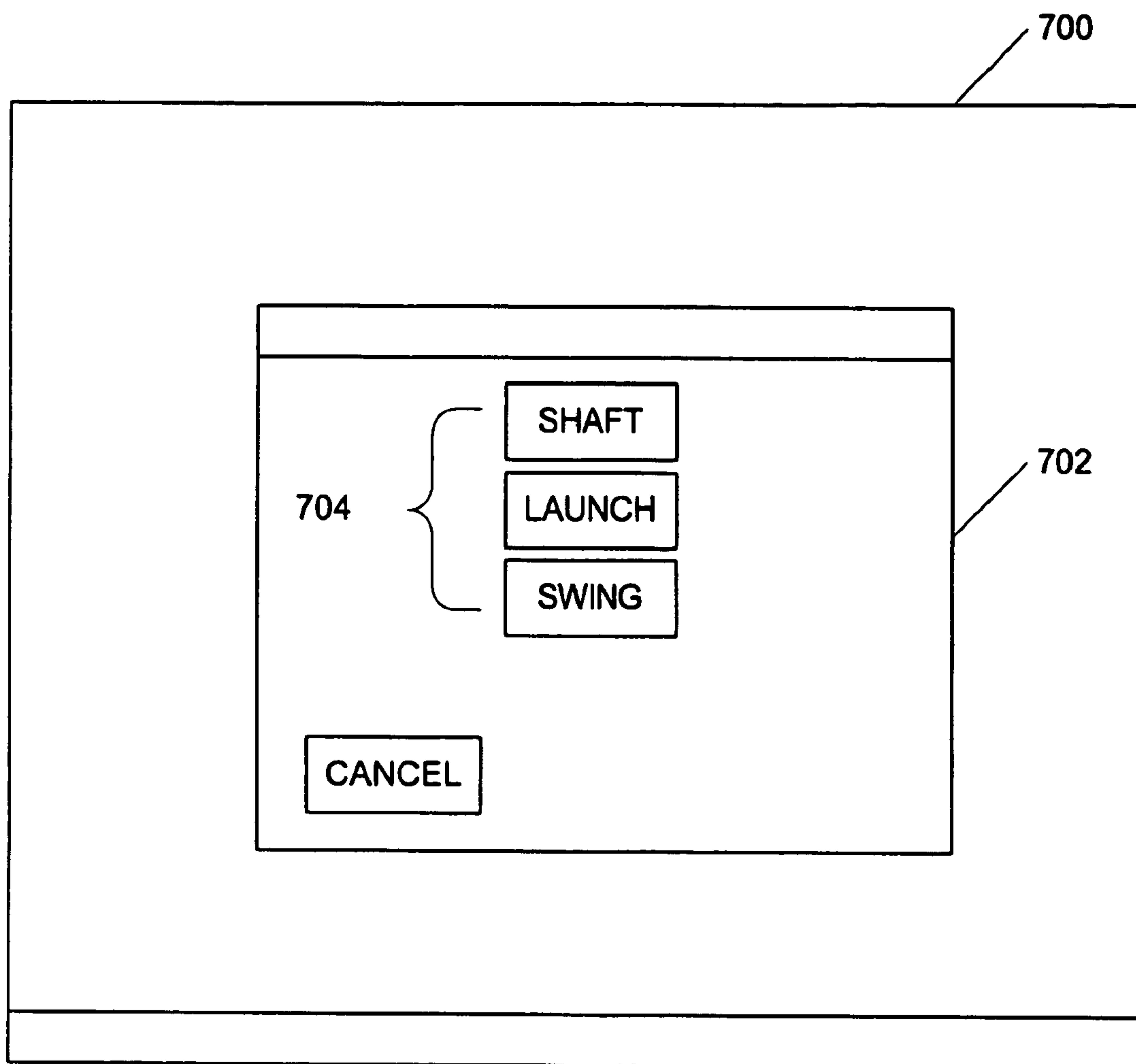

FIG. 7

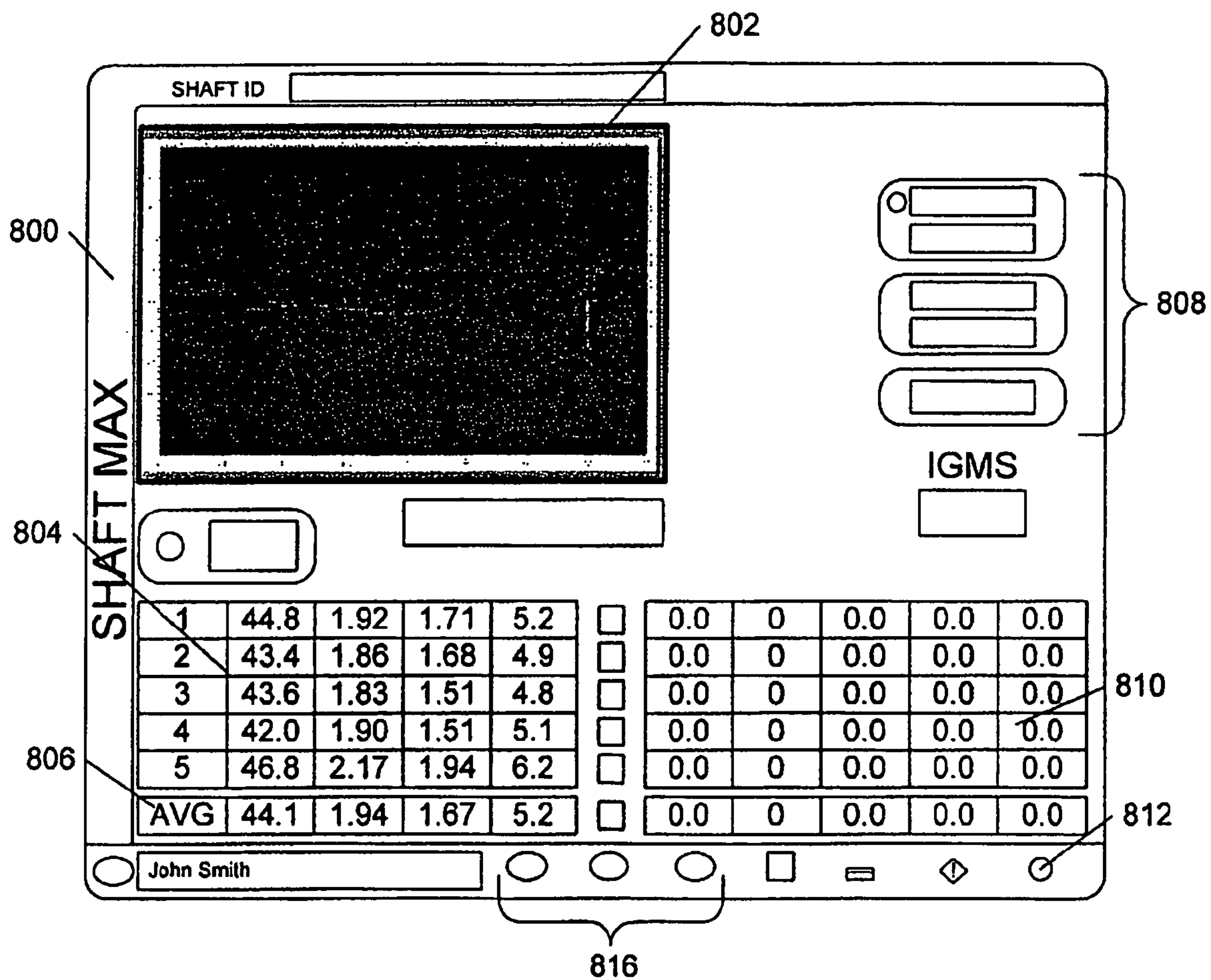

FIG. 8

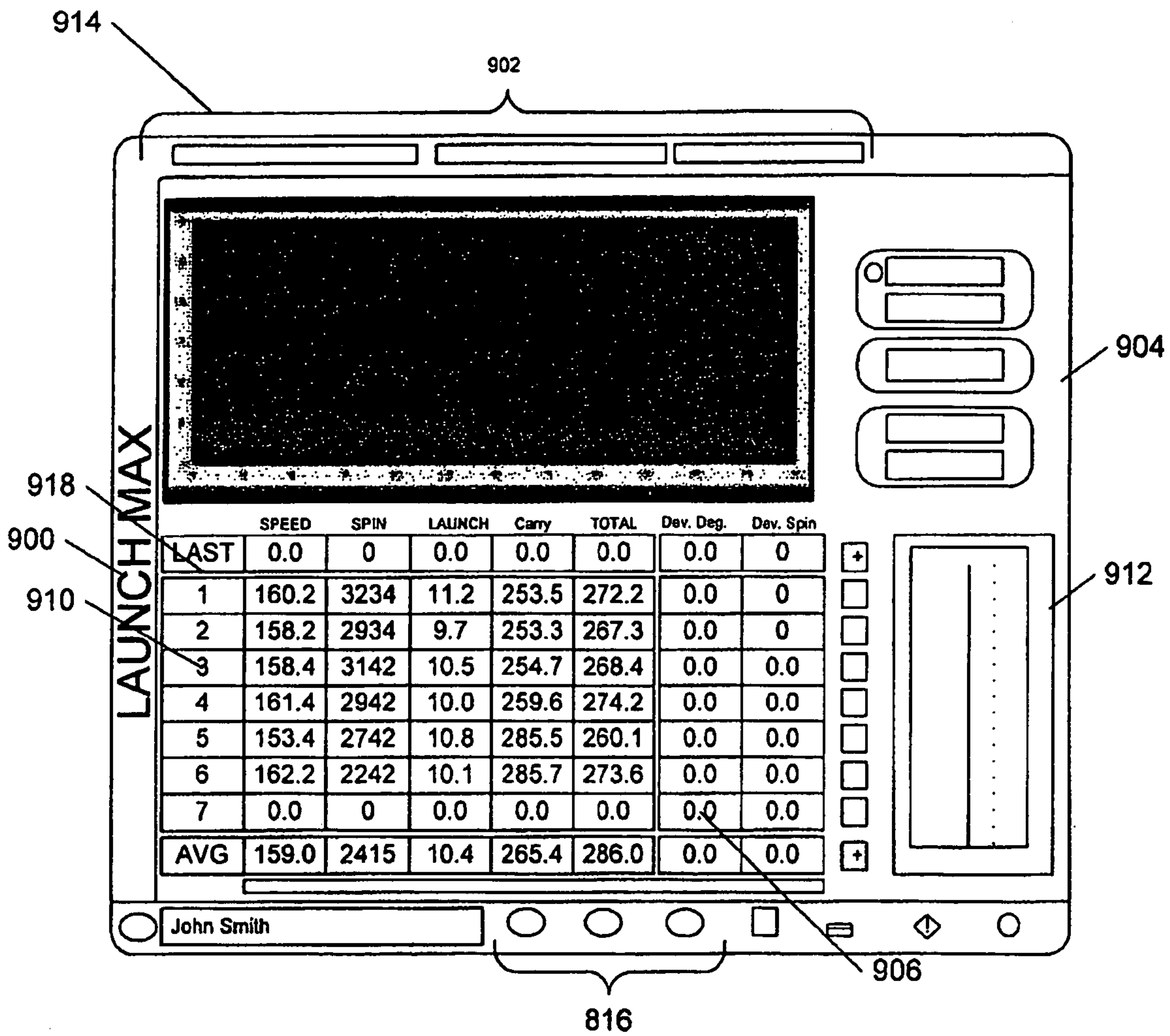

FIG. 9

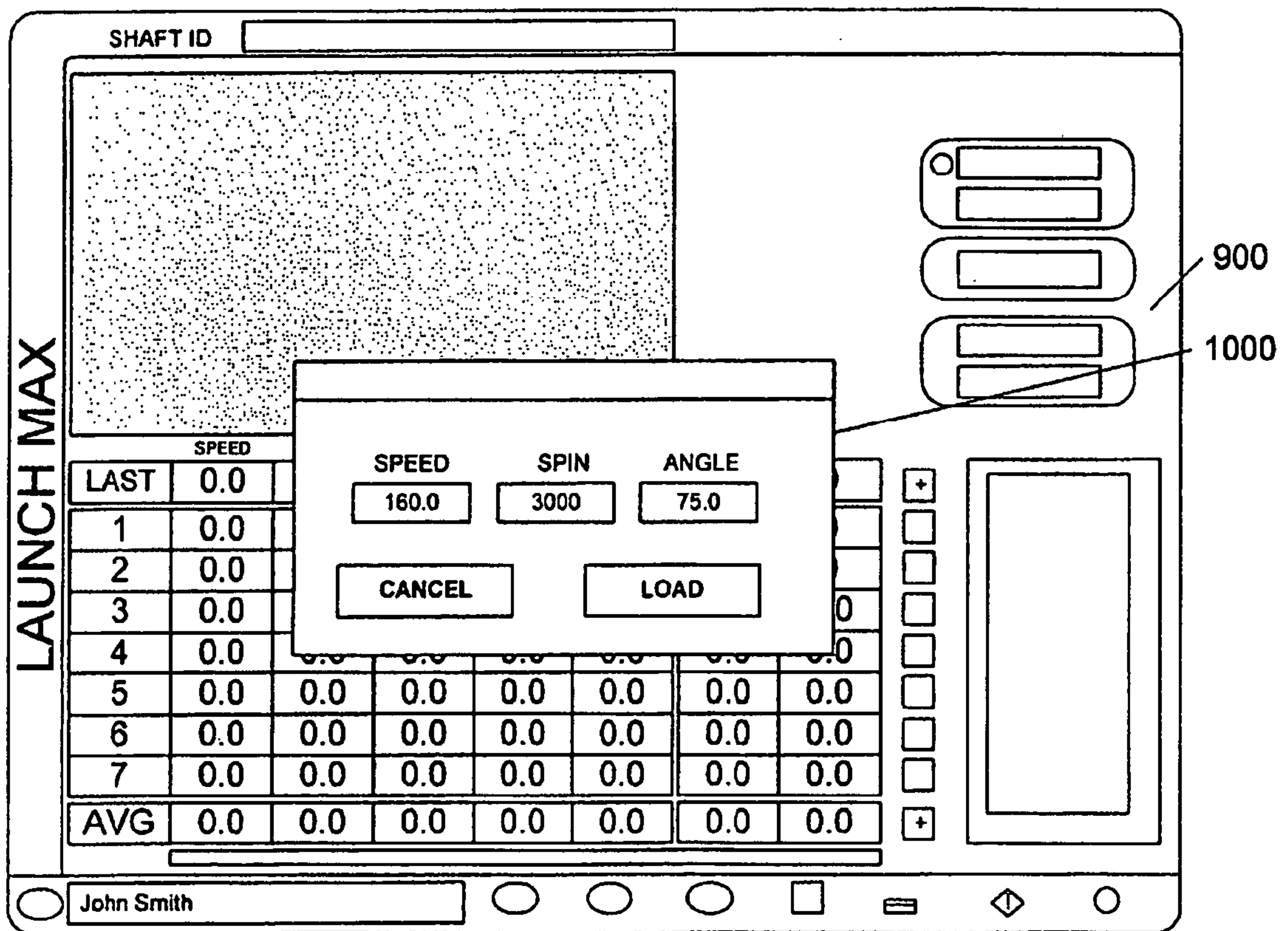

FIG. 10

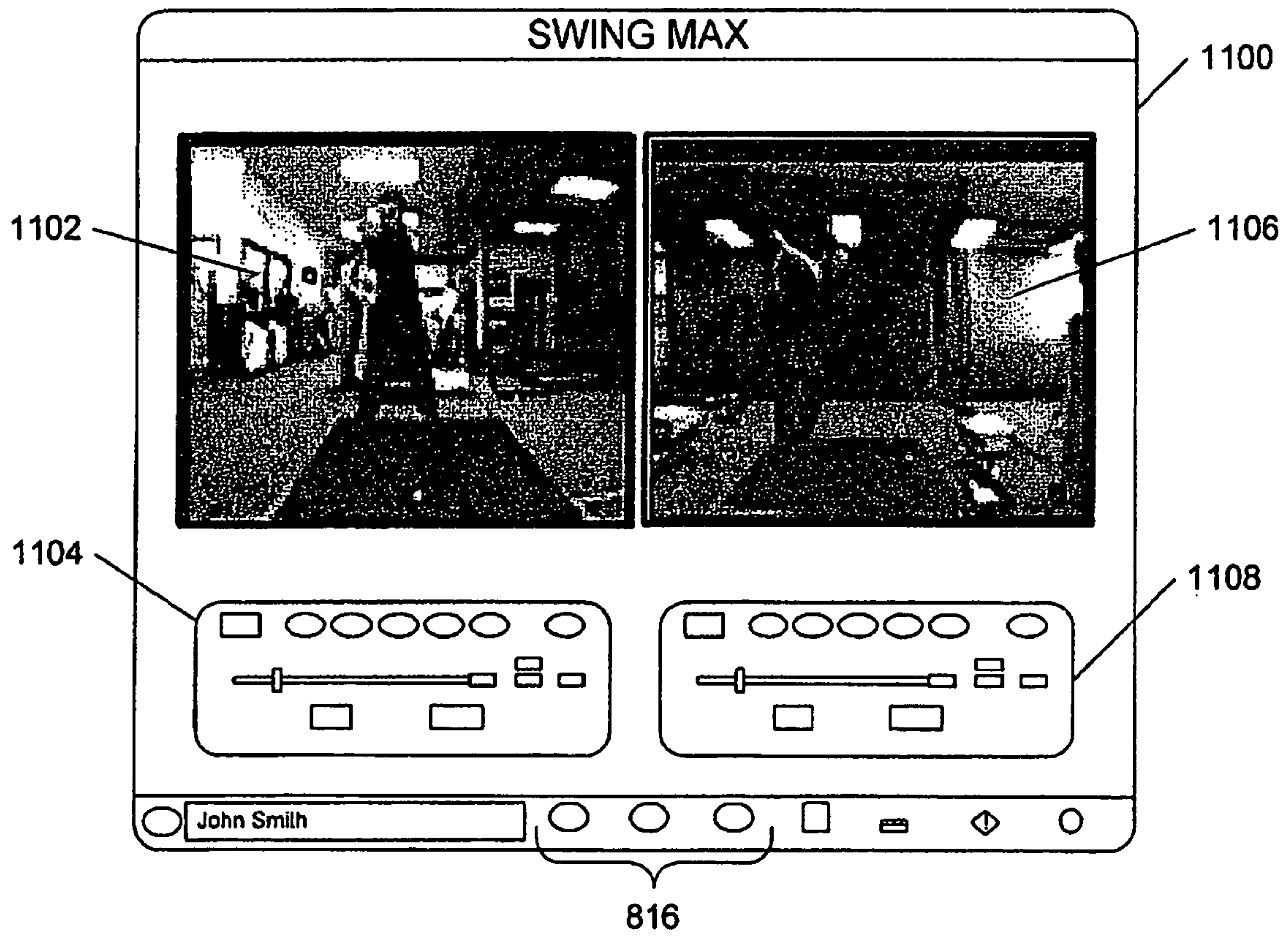

FIG. 11

1200

HEAD	<input type="text"/>	<input type="text"/>	<input type="text"/>	
SHAFT	<input type="text"/>	<input type="text"/>	<input type="text"/>	<input type="text"/>
BALL	<input type="text"/>	<input type="text"/>		
<input type="text"/>				
<input type="button" value="CLEAR"/>				

FIG. 12

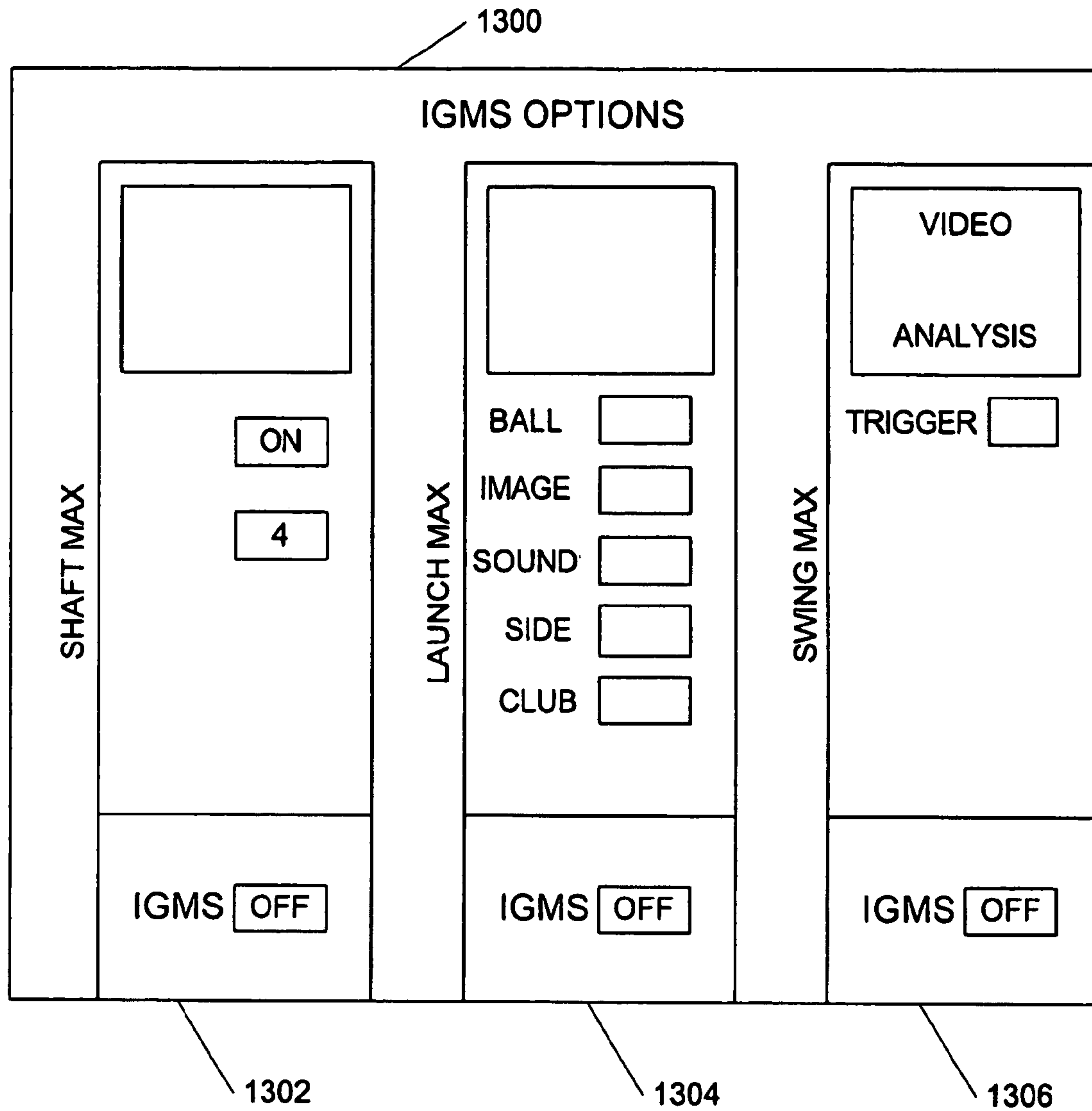

FIG. 13

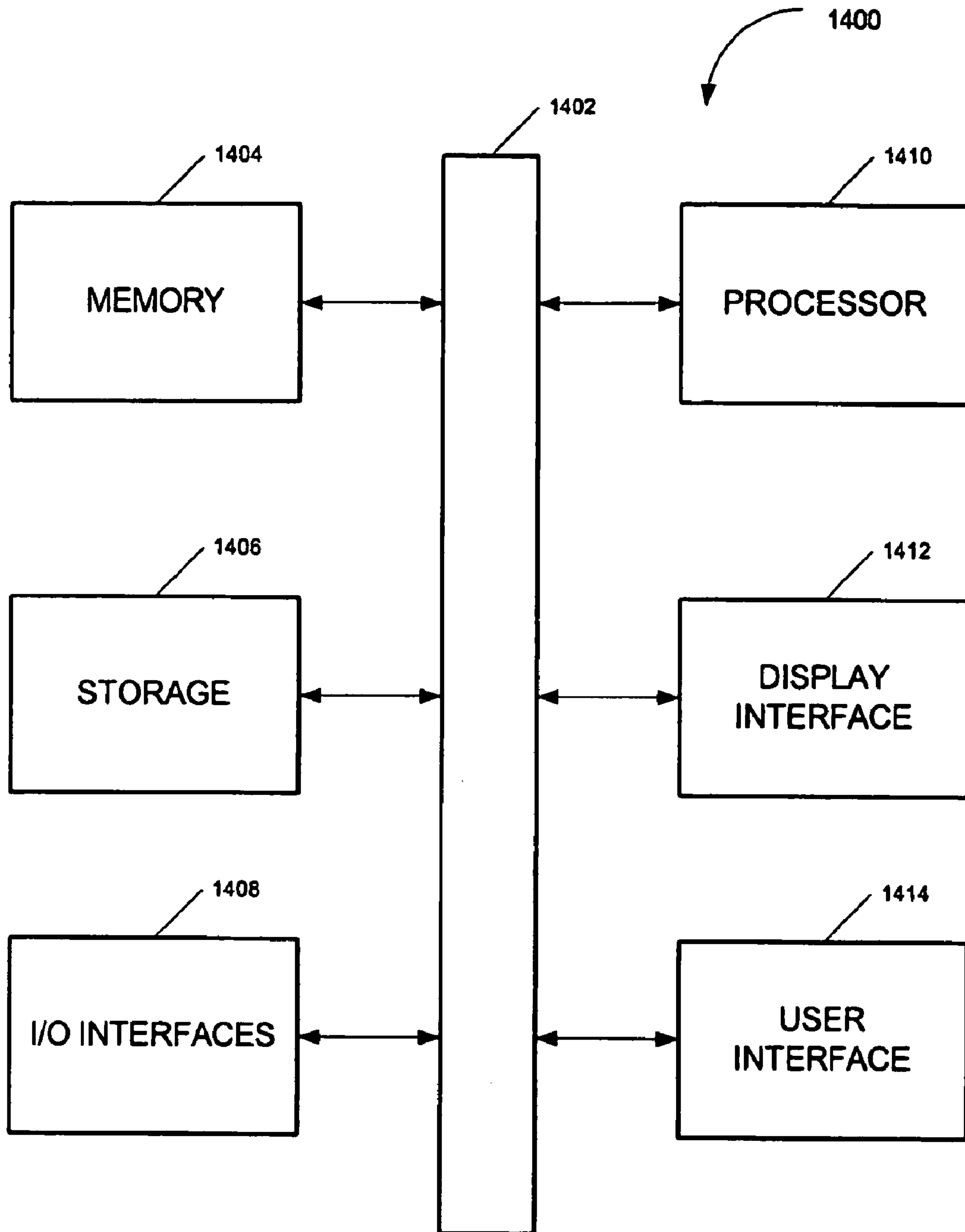

FIG. 14

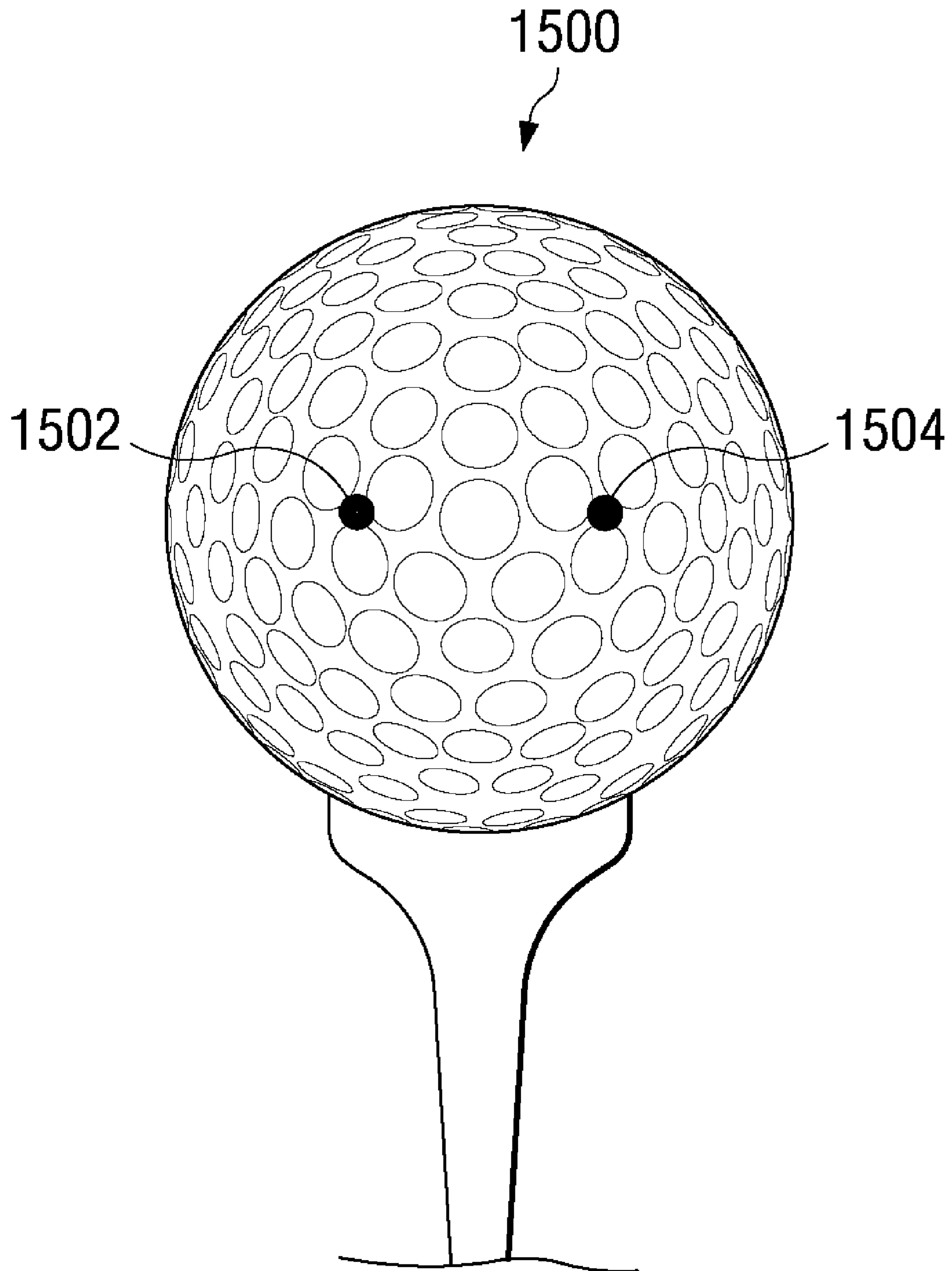

FIG. 15

SYSTEMS AND METHODS FOR FITTING GOLF EQUIPMENT

RELATED APPLICATION INFORMATION

The present application claims priority as a continuation-in-part under 35 U.S.C. §120 to U.S. patent application Ser. No. 10/053,797, entitled "Golf Club Woods With Wood Club Head Having a Selectable Center of Gravity and a Selectable Shaft," filed Jan. 18, 2002, which is incorporated herein by reference in its entirety.

BACKGROUND

1. Field of the Inventions

The field of the invention relates generally to the fitting of golf equipment and more particularly to systems and methods designed to improve the golfer's swing and provide more precise club fitting.

2. Background Information

Systems and method for fitting golf equipment to a specific golfer are well known. The goal of such conventional club fitting techniques is to help improve a particular golfer's game by providing him with equipment that is suited for his particular swing. Conventional club fitting methods are often based on swing parameters that are poor metrics for defining the golfer's overall swing and equipment needs. For example, conventional fitting methods are often based primarily on club speed as measured by a swing speed gauge. Club speed alone, however, can result in poor club fitting, because club speed is not always a good metric for defining a golfer's equipment needs.

For example, two golfers can have the same club speed of 100 mph, which will often result in the same club recommendation, including club type, shaft length, shaft flex, and club face loft, when conventional fitting techniques are employed. One of these golfers, however, may launch the golf ball at a 15 degree angle relative to the ground, while the other launches the golf ball at a 3 degree angle. Further, one golfer's swing can result in the golf ball rotating at 5000 rotations per minute (rpm's), e.g., using a driver, while the other generates 2500 rpms. The rotations per minute of the golf ball is often referred to as the spin of the golf ball. Using conventional techniques, both golfers will often end up with the same shaft and loft recommendation. In fact, however, these golfers require very different equipment to achieve optimum results.

Another drawback of conventional fitting techniques is that such techniques fit the golfer as he currently plays without consideration of swing flaws, e.g., in the golfer's posture, grip, etc. Thus, existing techniques can condemn a golfer to a lifetime of inconsistent play, because the golfer is being told to use equipment that does not account for, or that masquerades, the golfer's swing faults. For effective equipment fitting to occur, there has to be a marriage of talent, technique, and technology to help a golfer play to his maximum potential and derive more enjoyment out of the game.

SUMMARY OF THE INVENTION

A golf equipment fitting system uses advanced technology to not only objectively identify the optimum equipment for a golfer, but to also identify and help correct swing flaws so that the golfer can achieve optimum performance on the golf course. In one embodiment, golf fitting includes collecting data related to the golfer's swing and determining if

the golfer's swing technique should be modified based at least in part on the collected swing data. When it is determined that the golfer's swing technique should be modified, then providing swing instruction to the golfer. When, however, it is determined that the golfer's swing technique is fine, then data is collected related to how the golfer's swing launches a golf ball. Finally, golf equipment, e.g., golf clubs, can be specified based on the collected swing data and launch data.

These and other features, aspects, and embodiments of the invention are described below in the section entitled "Detailed Description of the Preferred Embodiments."

BRIEF DESCRIPTION OF THE DRAWINGS

Features, aspects, and embodiments of the inventions are described in conjunction with the attached drawings, in which:

FIG. 1 is a flow chart illustrating an example method for fitting golf equipment in accordance with one embodiment of the invention;

FIG. 2 is a flow chart illustrating an example method for collecting swing data in accordance with the invention;

FIG. 3 is a flow chart illustrating an example method for collecting launch data in accordance with one embodiment of the invention;

FIG. 4 is a diagram illustrating example components that can comprise a golf equipment fitting system configured in accordance with one embodiment of the invention;

FIG. 5A is a diagram illustrating a double crest load pattern for a golfer's swing as determined by the process of FIG. 2;

FIG. 5B is a diagram illustrating a flat line load pattern for a golfer's swing as determined by the process of FIG. 2;

FIG. 5C is a diagram illustrating a single crest load pattern for a golfer's swing as determined by the process of FIG. 2;

FIG. 5D is a diagram illustrating an incline load pattern for a golfer's swing as determined by the process of FIG. 2;

FIG. 6 is a diagram illustrating an implementation of the system of FIG. 4 and the methods of FIGS. 1, 2, and 3;

FIG. 7 is a screen shot illustrating an example opening screen that can be displayed by the system of FIG. 4 to a user preparing to implement the methods of FIGS. 1, 2, and 3;

FIG. 8 is a screen shot illustrating an example shaft module screen that can be displayed by the system of FIG. 4 when implementing the method of FIG. 2;

FIG. 9 is a screen shot illustrating an example launch module screen that can be displayed by the system of FIG. 4 when implementing the method of FIG. 3;

FIG. 10 is a screen shot illustrating an example optimization screen that can be displayed by the system of FIG. 4 to optimize the data collected during implementation of the method of FIG. 3;

FIG. 11 is a screen shot illustrating an example swing module screen that can be displayed by the system of FIG. 4 when implementing the methods of FIGS. 1, 2, and 3;

FIG. 12 is a screen shot illustrating an example launch options screen that can be displayed by the system of FIG. 4 when implementing the method of FIG. 3;

FIG. 13 is a screen shot illustrating an example systems option screen that can be displayed by the system of FIG. 4 when implementing the method of FIG. 1;

FIG. 14 is a logical block diagram illustrating an exemplary computer that can be used to implement the system of figure; and

FIG. 15 is a diagram illustrating a golf ball marked with two different colors.

DETAILED DESCRIPTION OF THE
PREFERRED EMBODIMENTS

The golf equipment fitting process described herein can be implemented as a multi-step evaluation process that can be broadly divided into two phases. The first phase involves an evaluation of a golfer's current golf equipment and swing technique. The steps comprising the first phase require data collection to give discreet information concerning key attributes of the golfer's swing. The swing data gathered during the first phase can be used to identify major swing flaws so that these flaws can be corrected before fitting the golfer with golf equipment. This can result in better fitting of golf equipment, because if not corrected, the swing flaws will lead to inconsistent results regardless of the equipment being used. Moreover, if the golfer is fit for golf equipment based on his flawed swing, the equipment he was fitted with may no longer be appropriate if he later corrects the swing flaws. Thus, correcting swing flaws prior to beginning the club fitting process can result in a more optimized fitting. To this end, the systems and methods described herein can be used to aid in the identification and correction of swing flaws, which can be an integral part of the fitting process described below.

The second phase can involve collecting launch data and, in certain embodiments, combining it with swing data collected in the previous phase in order to fit the player with optimized equipment including shafts, clubs, and balls.

Thus, FIG. 1 is a flow chart illustrating an example method for fitting golf equipment in accordance with one embodiment of the systems and methods described herein. The method of FIG. 1 begins in step 102 where the golfer is interviewed in order to evaluate the current status of his golf game. Step 102 can, for example, include determining through the interview process: what equipment the golfers has been using; what the player considers to be the strengths and weaknesses of his golf game; the courses and conditions the golfer will likely encounter; the level of competition the golfer encounters; and an evaluation of the swing technique of the golfer.

Evaluating the swing technique of the golfer can comprise observing the golfer hit several golf balls. Often, a video system, such as video system 414 described below, is used to help evaluate the golfer's swing technique using, for example, a swing module 412, which is also described in more detail below.

At this point, certain swing flaws can be readily apparent. These swing flaws can, in certain embodiments, be adjusted prior to proceeding. In this case, identification of more subtle swing flaws can occur at a later stage. Alternatively, evaluation of swing technique and identification of swing flaws, no matter how apparent, can wait until swing evaluation, e.g., as described below in relation to step 106.

In step 104, the golfer's current golf clubs are evaluated. This evaluation can, for example, include measuring the flex, lie angle, and loft of the golfer's golf clubs. The flex can be measured using standard flex charts. The lie angle and loft are standard measurements of the golf club. Briefly, however, at address, the club shaft and the ground create an angle called the lie angle. In this position, the club is perfectly square to the target. Another way to describe the lie angle is the angle between the centerline of the golf club shaft and the horizontal grooves on the clubface. The same lie angle does not suit all players. Physical differences, e.g. height, arm-length, etc. can require a different lie angle for one golfer compared to another. Because proper lie angle is essential to achieving consistently solid, accurate shots, it is

important to measure the lie angle of the golfer's clubs. If the golfer's lie angle is "toe up," he will tend to hook the ball, and will benefit from a flatter lie angle; if the golfer's lie angle is "toe down," he will have a tendency to slice the ball, and will benefit from a more upright lie angle.

The loft is the angle that the golf club face makes relative to the centerline of the shaft. Adjusting the loft of standard club heads is an important method for compensating for the golfer's tendencies to hit higher or lower trajectories than normal.

Next, in step 106 the golfer's swing is evaluated and data is collected regarding the swing in step 108. This swing data can then be combined, in step 110, with the information gathered in step 102 to generate a baseline performance matrix for the golfer. The performance matrix can be used to help determine if the golfer's swing technique needs modification in step 112. If it is determined that the golfer's technique needs to be modified, then he can be given instruction in step 114. The instruction of step 114 should be designed to achieve specific modifications in the golfer's swing technique that will help the golfer to achieve a more efficient swing. Progress can be closely monitored, e.g., by repeating steps 106-114 as required.

Because the process of FIG. 1 can involve swing technique evaluation and instruction, it can be preferable for steps 102-114 to be carried out by, or with the assistance of, a golf professional. In fact, it can be preferable for the entire golf equipment fitting process to be carried out by a golf professional.

The swing evaluation and data collection of steps 106 and 108 are described in more detail below in relation to the flow chart of FIG. 2.

Once it is determined, in step 112, that the golfer's technique is sufficient, the data collected can be combined with launch data, in step 118, to fit the golfer with optimized equipment including shaft, club, and ball. The launch evaluation of step 118 is described in more detail below in relation to the flow chart of FIG. 3.

The launch evaluation of step 118 can be followed by further swing evaluation (step 106). Alternatively, all swing evaluation steps can be completed prior to the launch evaluation of step 118. In either case, once the swing evaluation, step 106, and launch evolution 118, are completed in step 116, then the resulting information can be used to specify parameters that describe the optimum golf equipment for the golfer in step 120.

FIG. 2 is a flow chart illustrating an example method for collecting swing data in accordance with the systems and methods described herein. First, in step 202 data related to the load time for the golfer's swing can be collected. The load time is defined as the time the golfer loads the shaft during his downswing. The loading starts just prior to, or at the top of, the golfer's back swing and ends at impact with the golf ball. The load time provides an indication of how quickly the golfer swings a golf club from the top of his back swing to impact with the golf ball. A load time that is too fast, or too slow tends to be difficult to repeat and can result in many of the typical performance problems that golfers experience. For example, a load time that is too long generally results in a lack of power and inconsistent launch conditions. It has been shown, using the systems and methods described, herein that load time is generally optimized when it falls between 0.45 to 0.50 seconds.

Next, in step 204, data related to the load pattern for the golfer's swing can be collected. The load pattern is defined as the deflection, or load of the golf club shaft as a function of time during the downswing. Different types of load

5

patterns indicate different swing tendencies. For example, a “single crest” load pattern as shown in FIG. 5C indicates a swing where the golfer tends to release his wrist too early. This situation is often referred to as casting, i.e., the golfer is casting the golf club much the same way a fishermen casts a fishing rod. In FIG. 5C, the y-axis corresponds to the deflection in inches, while the x-axis corresponds to time. The point of impact with the golf ball corresponds to the point 506 where the curve touches, or approaches, the x-axis. Thus, in FIG. 5C it can be seen from curve 510 that the golfer loaded the club early in the golf swing, creating significant deflection or load, but then released the load well before impact with the golf ball.

Accordingly, a “single crest” load pattern is sometimes said to indicate that the golfer loads the club too quickly at the initiation of the downswing and then decelerates during the rest of the downswing. A situation that is referred to as an “early load”.

A “double crest” load pattern is illustrated in FIG. 5A. A double crest load pattern can indicate a situation where the golfer initiates loading at the start of the downswing, as illustrated by crest 502, and then reloads the club with his wrist just prior to impact, as illustrated by crest 504. This is indicative of a golfer whose swing is not smooth and is typically too long which again makes it difficult to make consistent contact with the golf ball.

A “flat line” load pattern is illustrated in FIG. 5B. The flat line load pattern can indicate a situation where the golfer has little or no significant load during the downswing as illustrated by load pattern curve 508. A golfer with a flat line load pattern does not generate enough energy to deflect the shaft and will not create solid or consistent contact with the golf ball.

The “incline” load pattern illustrated in FIG. 5D, on the other hand, is indicative of an optimum load pattern. An incline load pattern is a linear loading, as illustrated by linear portion 512, of the shaft, where the crest load 514 occurs just prior to impact. A swing that results in an incline load pattern makes the most use of the stored energy in the shaft and is therefore the most efficient. Thus, it is preferable for the systems and methods described herein to help modify the golfer’s swing and fit him with golf equipment that will generate an incline load pattern swing after swing. In other words, the incline load pattern can be the model for the systems and methods describe herein.

In step 206, swing parameters that define the golfer’s swing can be derived from the swing data collected in steps 202 and 204. For example, in one embodiment, a load time can be derived from the load time data collected in step 202. The load time can be an average of the data collected for multiple swings. A peak load, or deflection, can also be derived from the load pattern data collected in step 204. Again the peak load can be averaged over several swings. A swing ramp can also be derived for the golfer. The swing ramp is a measure of the potential energy of the swing and can be measured in miles per hour. Thus, it is similar to the club speed used in conventional techniques.

The data collected in steps 202 and 204, and derived therefrom, can also be used to generate a shaft flex measurement. In other words, the load time, peak load, and swing ramp can be correlated to a standard shaft flex measurement. This measurement can simply be a standard numerical indicator that corresponds to a certain standard shaft flex, i.e., stiff, regular, etc.

The swing parameters derived in step 206 can then be displayed in step 208, e.g., by system 400 described below. For example, the parameters derived in step 206 can be

6

displayed in conjunction with a graph of the load pattern of step 204, i.e., the patterns of FIGS. 5A–5D. The displayed information can then be used to help evaluate the golfer’s swing in step 210 and to identify any swing flaws using the information displayed. For example, if the information displayed in step 208 indicates that the golfer has a “single crest” load pattern, then this can be identified in step 212 and instruction can be given to the golfer to correct the early release, or casting, flaw in the golfer’s swing.

In certain embodiments, a video system, such as video system 414 can be used in conjunction with the swing data collected in steps 202–206 and displayed in step 208 to analyze the golfer’s swing. Such a video system can comprise video, or high-speed cameras oriented, for example, directly behind the golfer and pointed down the target line and/or facing the golfer as he makes his swings. The images of the golfer’s swing generated by the video system can then be displayed and can be correlated to the load pattern. Thus, when the load pattern indicates a problem, the swing video can be consulted to help assess the problem and to allow the golfer to visualize the swing flaw and begin working to correct it. Various swing flaws, which result in improper load time and load pattern, can then be corrected in step 214. This process, which is useful in modifying the golfer’s technique also results in increased ball speed, appropriate launch angle, and spin rates.

As the golfer works to correct his swing in step 214, steps 202–212 can be repeated until a more optimum swing is achieved. This results in a better swing and a better fitting than conventional fitting techniques, because the golfer swing is improved to the point where he can make better more consistent contact, rather than fitting the golfer for equipment when his swing has flaws that will prevent him from consistently making contact even with his new fitted equipment.

Once the golfer’s swing technique is sufficient to proceed with the fitting process, a shaft stiffness recommendation can be obtained from the swing parameters derived in step 208. For example, the swing characteristics derived in step 208 can be used to recommend shaft stiffness for the golfer.

Once the swing data is collected, the golfer’s swing can be examined to determine how he launches a golf ball. FIG. 3 is a flow chart illustrating an example for collecting launch data in accordance with one embodiment of the systems and methods described herein. First, in step 302, launch data can be collected. In one embodiment, launch data is collected for the golfer using the golfer’s driver. Launch data can be collected using a high-speed camera system, such as a system 416, focused closely on the golf ball. The golf ball is then marked with particular markings to allow launch data to be derived from the high-speed pictures obtained from the high-speed camera system. Launch data can include, e.g., the initial velocity of the golf ball as it is launched, the spin rate of the golf ball as it is launched, and the launch angle of the golf ball relative to the ground.

The spin rate can include components of backspin, side-spin, and rifle spin, each of which can be calculated depending on the embodiment. The launch angle can also include both components of left/right deviation with the target line and the angle with the horizon.

Once the launch data is collected in step 302, ball flight information can be derived in step 304 for each swing of the golf club. For example, based on the images captured by the high speed camera system, the ball speed, spin, and launch angle can be derived as well as how far the ball would have carried, an estimation of how far the ball would travel all

together, i.e., including roll, and a deviation from the center line. The deviation can be measured in degrees right or left of the centerline.

The information derived in step 304 can then be displayed in step 306, e.g., by system 400. For example, not only can the values for the derived information be displayed, e.g., in a table, but a graphical illustration of the ball flight can also be displayed.

The process of FIG. 3 can be started using the golfer's own driver, or other equipment. The data collected can then be used to start fine-tuning the golfer's equipment to achieve the optimum ball flight, including a fine-tuning of the shaft recommendation of step 216 described above. For example, in order to maximize driver distance one needs to match the golfer's ball speed with an optimized combination of launch angle and spin rate. Thus, after the golfer hits golf balls using his own club and data is collected and displayed in steps 302-306, a club with a shaft flex in the range of that recommended in step 216 can be used to obtain and display more data, i.e., steps 302-306 are repeated. The shaft flex can then be fine tuned in step 308, by continuing to use clubs with various shaft flexes until a shaft flex that appears optimal is determined. In addition, different clubs, with various shaft materials, gram weights, tip sections, lengths, torques and can be tested in steps 310-318, and steps 302-306 repeated, until an optimum ball flight is achieved as depicted, for example, by the data displayed in step 306. Various types of grips and grip weights can also be tested in steps 320-322.

It is well known that two different golf clubs can have the same frequency, or flex range, but have entirely different performance characteristics. For example, a shaft can be stiffer in the tip, or stiffer in the butt, when compared to another shaft. Torsional stiffness, or torque, can also play an important part in the overall performance of a golf club. Thus, although two different clubs can be well fitted to the golfer in terms of shaft stiffness, they can produce entirely different launch conditions. By finding the combination of shaft characteristics that maximizes, for example, distance off the tee, the golfer can be properly fitted with the best equipment for his technique. In other words, by continually fine tuning various aspects of the golf shaft to achieve an optimal ball flight, the best equipment for the particular golfer can be identified.

The driver is an important club for every golfer and has some very specific characteristics that may need to be adjusted to obtain the best driver performance for a particular golfer's technique. Accordingly, when fitting the golfer for a driver, various driver lofts (step 324), head types (step 326), and club head centers of gravity (step 328) can be tested to arrive at an optimal driver ball flight characteristic. In addition, different ball types can be tested in step 330 to optimize distance when using the driver. Different ball types have different spin rates, which should be matched to the launch angle and the ball speed. For example, a higher spin rate can cause the ball to get higher in the air off the club face, which can reduce distance. On the other hand, in certain instances a golfer may need to increase the spin rate in order to gain distance. Thus, the object of step 330 is to find the optimum spin characteristics for a particular golfer's ball flight trajectory and other characteristics. Often, the objective in driver fitting is to maximize distance, control, and consistency. Fitting the golfer to the appropriate shaft flex, driver lofts, shaft weights, ball type, club head type, center of gravity of club head, and shaft bend profiles can be intended to achieve as high a ball velocity as possible coupled with the appropriate launch angle and spin rate.

It should be noted that the process of FIG. 3 can be repeated for all of the golfer's clubs including the driver, fairway woods, irons, wedges, and putters. Each type of golf club results in a unique set of issues that have to be addressed, or optimized during the club fitting process. For the fairway woods and irons, for example, the target often is to have each club hit a certain distance with a high degree of repeatability. For the irons, each consecutive club in the set should have a distance gap between it and the next club so the golfer can easily achieve hitting the ball from any distance to the target. Thus, the goal is more directed toward tight dispersion and distance control rather than just distance. Therefore, the lofts of each club need to be set at the appropriate amount.

For wedges, the objective is to be able to achieve various types of short game shots. Some types of shots require maximum spin while others require higher launch angles. The fitting process of FIG. 3 can be tailored to achieve performance evaluation for various wedge types that will optimize lofts, flanges, bounce angles, and other features necessary to master various shots that can be encountered by the golfer.

Several techniques can be used to further optimize the club fitting process. For example, an optimum launch angle and spin rate can result in a ball flight that is too high, resulting in a loss of control. Thus, a maximum ball height can be used as a ceiling for the ball flight characteristics when testing various equipment in steps 308-330. For example, a good maximum ceiling height for the ball to fly during a drive is 125 feet. So the goal can be to get as high a launch angle and as low a backspin as possible as long as the ball flight is less than 125 ft. A trajectory model can then be used to predict the peak height a ball flies for a given launch condition, as determined in steps 302-306. A relationship that limits the launch angle and backspin for a given ball velocity so that the peak is less than 125 feet is then used when fitting the golfer with equipment. It should be noted that the maximum ceiling might change from golfer to golfer depending on the altitude and standard weather conditions of the golf course that the golfer typically plays.

Further, the process of constantly changing aspects, i.e., shaft, ball, club head, etc., and deriving new information each time can be very time consuming. To reduce the time required, a special type of club head can be used. For example, a driver head that can be manufactured to have the same dimensions but different centers of gravity can be configured so that the driver head can be quickly assembled onto a driver shaft. Different shafts, i.e., shafts of different materials, lengths, gram weights, torques, etc., and with different types of grips and grip weights can then be maintained and configured to quickly assemble onto the driver head.

For example, in one embodiment, the driver head can be configured to quickly snap, or twists onto the end of a shaft. The driver head can be further configured to work in conjunction with a fastener to ensure that the driver head stays on the shaft during testing. In one implementation, for example, a screw, such as an Alan Head screw, can be inserted through a hole in the driver head and down into the shaft. The screw can then be tightened to ensure the driver head remains secured to the shaft.

Thus, a stable of different shafts comprising different characteristics, and of different driver club heads, comprising different loft angles and centers of gravity, can be maintained so that they can be quickly assemble to create drivers with various characteristics for use, for example,

during the fitting process of FIG. 3. It should be apparent that similar techniques can be extended to other clubs as well.

In step 332, the lie angle of the golfer's clubs can be measured using, e.g., impact tape on the bottom of each club. This is often done for the irons and wedges. Thus, in step 332, the golfer can take equipment comprising characteristics derived at steps 302–330 and hit balls using the tape. The impact tape can help determine if the club head is in a “toe-up” or “toe-down” position at impact. Adjustments in the lie angle can then be made until the golfer is striking the ball constantly with the “sweet-spot” of the club face.

At this point, all of the information needed to fit the golfer with equipment that will result in optimum performance should be known and parameters associated with, or identifying, the optimum equipment can be derived in step 334.

In certain embodiments, the parameters of step 332 can be used to identify specific clubs, and manufacturers, that should work well for the golfer. The parameters can then be forwarded directly to the manufacturer as part of an order for customized clubs. Then, when the customized clubs arrive, they can be checked using the parameters to make sure they are right and adjusted or returned as required.

FIG. 4 is a diagram of a golf equipment fitting system configured in accordance with one embodiment of the systems and methods described herein. In the example of FIG. 4, system 400 comprises three main components: a shaft-fitting component 420; a launch fitting component 422 and a swing assessment component 424. In one embodiment, shaft-fitting component 420 comprises a shaft module 408 and a wireless receiver 404. Wireless receiver 404 can be configured to receive swing data from a wireless transmitter 402, which can be interfaced with strain gauges coupled to a golf club shaft being swung by the golfer.

In conventional shaft fitting systems, strain gauges are often wired to a system that collects swing data from the strain gauges. The wires, however, can get in the way and impede the golfer's natural swing and thereby compromise the swing data being collected. Using a wireless interface can help eliminate this problem. In certain embodiments, wireless transmitter 402 can be interfaced with several strain gauges disposed along the shaft of the golf club. Often, the strain gauges are disposed inside the shaft itself. Wireless transmitter 402 can, for example, be coupled with a strap configured to strap the transmitter to the golfer's wrist. In such an implementation, there can be wires coming from the end of the shaft to the wireless transmitter, which is strapped to the golfer's wrist. Thus, it is important to use enough wire so that wireless transmitter 402 does not interfere with the golfer's swing.

In an alternative embodiment, each strain gauge can be comprise its own wireless transmitter 402. For example, a strain gauge and wireless transmitter 402 can be included in a single device installed inside the shaft. Alternatively, one or more wireless transmitter can be inserted into the shaft, or otherwise disposed on the shaft and interfaced with one or more strain gauges.

Swing data collected from the strain-gauged clubs, e.g., via wireless receiver 404, can be used to help approximate the proper shaft flex and tip section recommendations as describe above. The strain-gauged clubs not only measure how the shaft is loaded but also the deflection of the shaft during the swing. The collected swing data is then sent to shaft module 408 for processing in accordance with the system and methods described herein. The processed data can then be turned into shaft recommendations. For example, the peak deflection during the downswing can

indicate the proper shaft flex for the golfer. The higher the peak load or deflection, the more stiff a shaft the golfer may need, e.g., a golfer with a peak deflection of greater than 4.5" can need a shaft that is S or X flex. A golfer with a peak deflection of <3", on the other hand, can need a L, A, or R flex shaft. All others can need an R or S flex shaft. Also, the thrust velocity of the shaft through impact can be determined by shaft module 408 and used to determine an approximate shaft tip recommendation. A golfer with a relatively high thrust velocity of greater than 5 mph, for example, can be biased toward a stiffer shaft.

Additional information such as a lead or lag deflection or a toe up or tow down deflection can be derived from the strain gauges. Such information can indicate flaws in the golfer's swing and therefore may be addressed earlier in the process, or they can indicate golf equipment recommendations. Ultimately, an appropriate ratio of butt flex to tip flex, gram weight, and length can be determined by shaft module 408 using the swing data collected via wireless receiver 404.

Launch fitting component 422 can, in one embodiment, comprise a high-speed camera system 416 and a launch module 410. High-speed camera system 416 can, for example, comprise a color CCD camera combined with a strobe unit. Conventional launch fitting systems often employ black and white cameras; however, this can limit the effectiveness of the club fitting process, because the spin information obtained for the golf ball after club impact can be less accurate than required. This is because the software configure to process the black and white images cannot always obtain the requisite information with the accuracy required due to the nature of the black and white images.

By using a color high-speed camera, more accurate, or more reliable launch data can be obtained. For example, because a color high-speed camera is used, markings comprising two or more different colors, e.g., blue and red, can be placed on the golf ball and used to derive spin information. Images can, for example, be acquired by firing the strobe as the golf ball is impacted and is launched from the clubface. High-speed camera system 416 can then be configured to acquire two images during this period. The two different color markings will be in a certain position in the first image, but will have changed positions in the second image according to the spin of the golf ball as well as the trajectory of the golf ball.

FIG. 15 is a diagram illustrating a golf ball 1500 configured with markings of two or more different colors. In the example of FIG. 15, marking 1502 can be one color, e.g., blue, while marking 1504 is another color, e.g., red.

Using digital signal processing techniques, for example, launch module 410 can be configured to derive the spin and launch information from the images capture by high-speed camera system 416. It should be apparent that in a black and white system, the markings may not be easily discernable, thus rendering the information gathered in conventional systems less accurate.

Swing assessment component 424 can comprise a video system 414 and a swing module 412. Video system 414 can comprise one or more video cameras, or one or more high-speed cameras, depending on the implementation. For example, one video camera can be placed in front of the golfer and one can be positioned down the target line of the golfer's swing. Images captured by the cameras are sent to swing module 412, which can process them and save them into a storage medium. The images can then be pulled up and displayed. The images can be allowed to run, i.e., like a video stream so that the golfer can view his swing. The images can then be used to assess the golfer's swing in

association with the information being gathered and displayed by shaft module **408** and launch module **410**. To help in the assessment, it can be preferable to allow the images to be paused, rewound, fast forwarded, etc.

It will be understood that shaft module **408**, launch module **410**, and swing module **412** can comprise the requisite hardware, software, or combination thereof required to implement the functions described above. Thus, each module can comprise a standalone system. In alternative embodiments, however, each module can comprise part of a larger system **406**. For example, each module can comprise part of a software program loaded onto a single computer system. An exemplary computer system is described in more detail below. But it should be noted that such a computer system can comprise customized hardware or software components or interfaces as required by a particular module.

For example, as illustrated in FIG. 6, system **400** can be adapted so that it can be included in a kiosk **600** with a display **602** for displaying the information as described above. Thus, kiosk **600** can comprise a computer system configured to implement the functionality of shaft module **408**, launch module **410**, and swing module **412**. As can be seen, a golfer **606** can stand on a mat **612** and make several swings. The computer system included in kiosk **600** can then receive swing data from strain gauges disposed on shaft **608**. Launch data can be obtained from high-speed camera **604**. The computer system can process the received data and generate information to be displayed on display **602**.

Thus, for the first time launch information can be easily and readily combined with other information, such as that provided by shaft module **408** to more effectively fit the golfer with equipment. Moreover, images of the golfer's swing can be acquired by swing module during the fitting process and used evaluate the golfer's swing. In this manner, flaws in the golfer's swing, e.g., as indicated by the launch or swing data collected by launch module **410** and shaft module **408** respectively, can be viewed and hopefully corrected using the images captured and displayed by swing analysis component **424**. Having all three components **420**, **422**, and **424** available in the same system **400** makes fitting easier and more effective. Further, as explained below, system **400** can be configured to allow a user to access information from each component **420**, **422**, and **424** as required during the fitting process. This makes fitting even more efficient and effective.

FIGS. 7–13 are screen shots illustrating various screens that can be displayed on display **602**. Thus, in FIG. 7 a screen shot of an opening screen **700** that can be displayed when a user, i.e., a golf pro preparing to fit a golfer with golf equipment, can see when they first run the software loaded onto the computer system included in kiosk **600**. In screen **700**, a selection window **702** is displayed that allows the user to access one of several functions, e.g., via radio buttons **704**.

The user can, for example, proceed past opening screen **700** by electing to start a new fitting process using radio buttons **704**. This can cause a shaft module screen **800**, such as the one illustrated by the screen shot of FIG. 8, to be displayed to the user. Shaft module screen **800** can be used to display the information generated by shaft module **408**. Thus, screen **800** can include a graphical display area **802** configured to display information related to the loading of a shaft being swung by a golfer being fitted for golf equipment using, e.g., kiosk **600**. The information displayed in area **802** can comprise curves, such as those depicted in FIGS. 5A through 5D, for each swing. The curves being displayed in

area **802** can be used to assess the golfer's swing in order to help the golfer make needed swing improvements to optimize the fitting process.

Additionally, screen **800** can include a table **804** in which swing parameters, e.g., time, peak flex, ramp potential, and corresponding flex, derived for each swing can be displayed. In the example of FIG. 8, data can be displayed for the previous **5** swings. The bottom row **806** of table **804** can be used to display averages for the values displayed in the table. The average values can be used, for example, to make shaft recommendations for use in the rest of the fitting process as described above and as further illustrated below.

Screen **800** can also include a table **810** that can be used to display information obtained during launch analysis described below. Thus, the user can have launch analysis information available in order to help the user recommend a shaft or analyze the golfer's swing. As can be seen, in the example of FIG. 8, the launch data for the previous **5** swings can be displayed in table **810**. Further, screen **800** can include a toolbar **812**, with radio buttons **816** that allow the user to quickly jump from shaft module screen **800** to the launch module screen **900** and to swing module screen **1100**. Screens **900** and **1100** are described below, but the ability to quickly access these screens allow the user to more effectively use all the tools available to analyze the golfer's swing in order to arrive at an optimal equipment fitting recommendation.

Screen **900**, illustrated in the screen shot of FIG. 9, can actually be displayed by launch module **410** while launch data is being gathered. Thus, screen **900** can comprise a table **910** for displaying the launch information being derived, e.g., ball speed, spin, launch angle, carry distance, and total distance. Additionally, table **910** can comprise columns **906** for data related to the deviation of the ball flight from the center, or target line. Thus, columns **906** can be used to display a deviation from the centerline in degrees as well as side spin information.

Table **910** can also include a row **918** in which averages for the values displayed in table **910** can be displayed. For example, in the embodiment of FIG. 9, column **918** is used to display averages for the previous **7** swings. The information from table **910** can then be propagated to screen **800** in table **810**. Thus, depending on the number of columns in table **910**, some or all of the launch data from screen **900** can also be displayed in screen **800**, with the ability to quickly jump from one screen to the other using radio buttons **816**.

Screen **900** can also include a graphic data area **914** for displaying graphical information related to ball flight as derived, e.g., by launch module **410**. Thus, a graph of the ball flight illustrating height, e.g., in feet, and distance, e.g., in yards, can be displayed in area **914**. Additionally, another graphical area **912** can be included to graphically illustrate the deviation from the centerline. Thus, area **912** can be configured to graphically illustrate a distance, e.g., in yards, and a deviation, e.g., in degrees. Radio control buttons **904** can be included to allow the user to graphically display, in areas **914** and **912**, data for each swing, a particular swing such as the last swing, the average of all swings, etc. Similar control buttons **808** can be included in screen **800**.

Screen **900** can also include a tool bar **902** in which information related to the equipment currently being used can be displayed. Thus, the golfer can make a few swings and launch data can be gathered and displayed on screen **900**. Based on the information, the user can suggest equipment changes, i.e., a lower spinning ball, a stiffer shaft, etc. and new data can be acquired and displayed. Each time equipment, or aspects of the equipment, is changed, the

information in toolbar **902** can be updated. This way, neither the user, nor the golfer, is required to remember what equipment they are currently using. This is helpful, because the golfer can make several equipment changes, based on the launch information being collected and displayed, until an optimum ball flight is achieved.

A launch optimization screen **1000**, as illustrated in FIG. **10**, can even be invoked to help optimize the launch data being collected. Thus, for example, launch optimization screen can be used to quickly assess the optimum launch conditions for a certain golfer based on information collected by launch module **410**.

Swing module screen **1100**, an example of which is illustrated by the screen shot of FIG. **11**, can be included to allow the user and the golfer to view the images captured by video system **414** and processed by swing module **412**. Screen **1100** can, as illustrated in the example of FIG. **11**, comprise two halves, with each half comprising a video display area **1102** and **1106** and control areas **1104** and **1108** respectively. In FIG. **11**, the controls comprising control area **1104** can be used to play, freeze, rewind, fast forward, etc. the images being displayed in video display area **1102** in much the same way VCR controls work. Video display area **1106** can display real time images. The images being displayed can, in certain embodiments, be switched from one camera making up video system **414** to the next. Further, in certain embodiments, one half of screen **1000** can be used to display images from one camera, while the other half is used to display images from another camera.

Launch options screen **1200**, illustrated by the example screen shot of FIG. **12**, can be used to enter information about the equipment presently being used in conjunction with gathering launch data to be displayed in screen **900**.

Options screen **1300** can be included to display information related to each of screen **800**, **900**, and **1100** simultaneously. Thus, screen **1300** can comprise a shaft area **1302** in which controls for the operation of shaft module **408** can be manipulated. Similarly, screen **1300** can comprise launch area **1304** and swing area **1306** in which controls for the operation of launch module **410** and swing module **412**, respectively, can be manipulated.

Thus, the fitting processes and techniques described above can be implemented via a kiosk, such as kiosk **600**, using screens such as those just described. As mentioned, modules **408**, **410**, and **412** can be implemented as software modules, possibly with associated specialized hardware interfaces, within a computer system in kiosk **600**. In other words, kiosk **600** can comprise a computer system loaded with software modules **408**, **410**, and **412**. FIG. **14** is a logical block diagram illustrating an example embodiment of a computer system **1400** that can be used to implement the system of FIG. **4**.

As will be understood, some type of processing system is always at the heart of any computer system, whether the processing system includes one or several processors included in one or several devices. Thus, computer system **1400** of FIG. **14** is presented as a simple example of a processing system. In the example of FIG. **14**, computer system **1400** comprises a processor **1410** configured to control the operation of computer system **1400**, memory **1404**, storage **1406**, a Input/Output (I/O) interfaces **1408**, a display output **1412**, a user interface **1414**, and a bus **1402** configured to interface the various components comprising computer system **1400**.

Processor **1410**, in one embodiment, comprises a plurality of processing circuits, such as math coprocessor, network processors, digital signal processors, audio processors, etc.

These various circuits can, depending on the embodiment, be included in a single device or multiple devices. Processor **1410** also comprise an execution area into which instructions stored in memory **1404** are loaded and executed by processor **1410** in order to control the operation of computer system **1400**. Thus, for example, by executing instructions stored in memory **1404**, processor **1410** can be configured to implement the functionality of modules **408**, **410**, and **412**.

Memory **1404** can comprise a main memory configured to store the instructions just referred to. In one embodiment, memory **1404** can also comprise a secondary memory used to temporarily store instructions or to store information input into computer system **1400**, i.e., memory **1404** can act as scratch memory also. Memory **1404** can comprise, depending on the embodiment, a plurality of memory circuits, which can be included as a single device, or as a plurality of devices.

Storage **1406** can include, in certain embodiments, a plurality of drives configured to receive various electronic media. For example, in one embodiment, storage **1406** includes a floppy drive configured to receive a floppy disk, a compact disk drive configured to receive a compact disk, and/or a digital video disk drive configured to receive a digital videodisk. In another embodiment, storage **1406** can also include disk drives, which can include removable disk drives. The drives included in storage **1406** can be used, for example, to receive electronic media that has stored thereon instructions to be loaded into memory **1404** and used by processor **1410** to control the operation of computer system **1400**.

I/O interfaces **1408** can be configured to allow computer system **1400** to interface with devices such as video system **414**, high-speed camera system **416**, and receiver **404**. Thus, I/O interface **1408** can comprise the interface hardware required to receive signals from the various components used to collect the data used by modules **408**, **410**, and **412**.

Display interface **1412** can be configured to allow computer system **1400** to interface with a display. Thus, computer system **1400** can display the information, described in relation to the example screen shots described above, to a user via display interface **1412**.

User interface **1414** can be configured to allow a user to interface with computer system **1400**. Thus, depending on the embodiment, user interface **1414** can include a mouse interface, a keyboard interface, an audio interface, etc.

It should be clear that the general description of a computer system provided above is by way of example only and should not be seen to limit implementation of system **400** to any particular computer architecture or implementation. Rather any architecture or implementation capable of implementing the processes and functionality described above can be used to implement the systems and methods described herein.

While certain embodiments of the inventions have been described above, it will be understood that the embodiments described are by way of example only. Accordingly, the inventions should not be limited based on the described embodiments. Rather, the scope of the inventions described herein should only be limited in light of the claims that follow when taken in conjunction with the above description and accompanying drawings.

What is claimed:

1. A golf equipment fitting system, comprising:
 - a launch data collection system, comprising a high speed color camera system configured to obtain information related to the launch of a golf ball based on color

15

- markings on the golf ball, the color markings comprising at least two different colors;
- a swing data collection system, comprising:
- a strain gauge configured to sense shaft deflection;
 - a wireless transmitter coupled to the strain gauge, the wireless transmitter configured to receive data from the strain gauge and to transmit the received data; and
- a processor system configured to optimize the launch angle, spin rate, and velocity of a golf ball for a particular golfer based on the received launch information and strain gauge data, wherein the launch angle, velocity, and spin rate are optimized so as to allow the golfer to achieve maximum distance and control when hitting a golf ball.
2. The golf equipment fitting system of claim 1, wherein the swing data collection system is further configured to derive a load time for the golfer's swing based on the received swing data.
3. The golf equipment fitting system of claim 1, wherein the swing data collection system is further configured to derive a load pattern for the golfer's swing based on the received swing data.
4. The golf equipment fitting system of claim 1, wherein the swing data collection system is further configured to derive ramp potential for the golfer's swing based on the received swing data.
5. The golf equipment fitting system of claim 1, wherein the swing data collection system is further configured to derive a load time, a load pattern, and a ramp potential based on the received swing data and to derive a shaft flex based on the derived load time, load pattern, and shaft potential.
6. The golf equipment fitting system of claim 1, wherein the golf fitting system further comprises a display, and wherein the swing data collection system is configured to display information related to the received data on the display.
7. The golf equipment fitting system of claim 6, wherein the swing data collection system is configured to display the information in a graphical format.
8. The golf equipment fitting system of claim 1, wherein the strain gauge is configured to sense the lead or lag deflection of the shaft.
9. The golf equipment fitting system of claim 1, wherein the strain gauge is configured to sense the toe up or toe down deflection of the shaft.
10. The golf equipment fitting system of claim 1, wherein the strain gauge is configured to sense a peak deflection of the shaft.
11. The golf equipment fitting system of claim 1, wherein the swing data collection system further comprises a strap configured to secure the wireless transmitter.

16

12. The golf equipment fitting system of claim 11, wherein the wireless transmitter is coupled to each of the plurality of strain gauges, and wherein the wireless transmitter is configured to receive data from each of the plurality of strain gauges and to transmit the received data to the shaft fitting system.
13. The golf equipment fitting system of claim 1, wherein the strain gauge and wireless transmitter comprises a single device.
14. The golf equipment fitting system of claim 1, wherein the swing data collection system further comprises a plurality of strain gauges each of the plurality of strain gauges configured to sense shaft deflection.
15. The golf equipment fitting system of claim 14, wherein the swing data collection system further comprises a plurality of wireless transmitters, each of the plurality of wireless transmitters coupled to one of the plurality of strain gauges, and wherein each of the plurality of wireless transmitters is configured to receive data from the associated strain gauge and transmit it to the shaft fitting system.
16. The golf equipment fitting system of claim 1, wherein the information obtained by the launch data collection system includes information related to the initial velocity of a golf ball as it is launched.
17. The golf equipment fitting system of claim 1, wherein the information obtained by the launch data collection system includes information related to the spin rate of a golf ball as it is launched.
18. The golf equipment fitting system of claim 17, wherein the spin rate information obtained by the launch data collection system includes information related to the backspin of the golf ball.
19. The golf equipment fitting system of claim 17, wherein the spin rate information obtained by the launch data collection system includes information related to the sidespin of the golf ball.
20. The golf equipment fitting system of claim 17, wherein the spin rate information obtained by the launch data collection system includes information related to the rifle spin of the golf ball.
21. The golf equipment fitting system of claim 1, wherein the information obtained by the launch data collection system includes information related to the launch angle of a golf ball as it is launched.

* * * * *

UNITED STATES PATENT AND TRADEMARK OFFICE
CERTIFICATE OF CORRECTION

PATENT NO. : 7,166,035 B2
APPLICATION NO. : 10/722579
DATED : January 23, 2007
INVENTOR(S) : Mitchell Clark Voges et al.

Page 1 of 1

It is certified that error appears in the above-identified patent and that said Letters Patent is hereby corrected as shown below:

On the Title Page add the following:
(73) Assignee: Max Out Golf, LLC., Sherman Oaks, California

Signed and Sealed this

First Day of April, 2008

A handwritten signature in black ink that reads "Jon W. Dudas". The signature is written in a cursive style with a large, looped initial "J".

JON W. DUDAS
Director of the United States Patent and Trademark Office