



US007150744B2

(12) **United States Patent**  
**Edwards et al.**

(10) **Patent No.:** **US 7,150,744 B2**  
(45) **Date of Patent:** **\*Dec. 19, 2006**

(54) **INFUSION ARRAY ABLATION APPARATUS**

(75) Inventors: **Stuart D. Edwards**, Los Altos, CA (US); **James Baker**, Palo Alto, CA (US); **Hugh Sharkey**, Redwood Shores, CA (US); **Ronald G. Lax**, Grass Valley, CA (US)

(73) Assignee: **Rita Medical Systems, Inc.**, Fremont, CA (US)

(\*) Notice: Subject to any disclaimer, the term of this patent is extended or adjusted under 35 U.S.C. 154(b) by 150 days.

This patent is subject to a terminal disclaimer.

(21) Appl. No.: **10/700,605**

(22) Filed: **Nov. 3, 2003**

(65) **Prior Publication Data**

US 2004/0181217 A1 Sep. 16, 2004

**Related U.S. Application Data**

(60) Continuation of application No. 09/513,725, filed on Feb. 24, 2000, now Pat. No. 6,641,580, which is a continuation-in-part of application No. 09/383,166, filed on Aug. 25, 1999, now Pat. No. 6,471,698, which is a continuation of application No. 08/802,195, filed on Feb. 14, 1997, now Pat. No. 6,071,280, which is a continuation-in-part of application No. 08/515,379, filed on Aug. 15, 1995, now Pat. No. 5,683,384, which is a continuation-in-part of application No. 08/290,031, filed on Aug. 12, 1994, now Pat. No. 5,536,267, which is a continuation-in-part of application No. 08/148,439, filed on Nov. 8, 1993, now Pat. No. 5,458,597, and application No. 09/513,725, Feb. 24, 2000, and a continuation-in-part of application No. 09/364,203, filed on Jul. 30, 1999, now Pat. No. 6,663,624, which is a continuation of application No. 08/623,652, filed on Mar. 29, 1996, now Pat. No. 5,935,123, which is a division of

application No. 08/295,166, filed on Aug. 24, 1994, now Pat. No. 5,599,345, which is a continuation-in-part of application No. 08/148,439, filed on Nov. 8, 1993, now Pat. No. 5,458,597.

(51) **Int. Cl.**  
**A61B 18/18** (2006.01)

(52) **U.S. Cl.** ..... **606/41; 607/101**

(58) **Field of Classification Search** ..... **606/41, 606/42, 45-50; 607/101, 102**

See application file for complete search history.

(56) **References Cited**

**U.S. PATENT DOCUMENTS**

4,565,200 A \* 1/1986 Cosman ..... 600/373  
(Continued)

**FOREIGN PATENT DOCUMENTS**

DE 21 24 684 A2 11/1972  
(Continued)

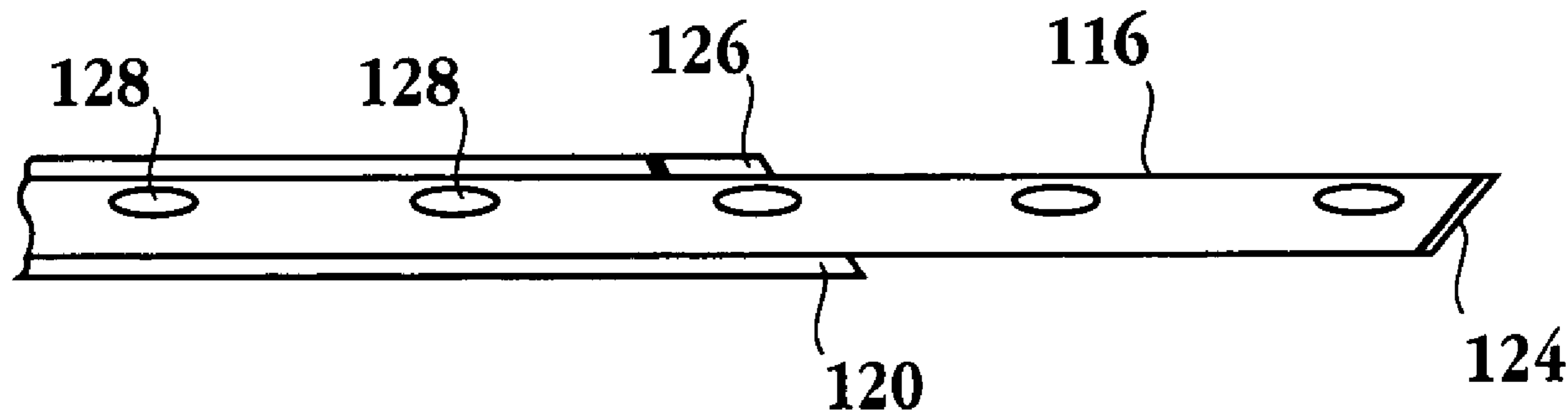
*Primary Examiner*—Michael Peffley

(74) *Attorney, Agent, or Firm*—Jacqueline F. Mahoney; Peter J. Dehlinger; Perkins Coie LLP

(57) **ABSTRACT**

An infusion array ablation apparatus includes an elongated delivery device having a lumen and an infusion array positionable in the lumen. The infusion array includes an RF electrode and at least a first and a second infusion member. Each infusion member has a tissue piercing distal portion and an infusion lumen. At least one of the first or second infusion members is positionable in the elongated delivery device in a compacted state and deployable from the elongated delivery device with curvature in a deployed state. Also, at least one of the first or second infusion members exhibits a changing direction of travel when advanced from the elongated delivery device to a selected tissue site. At least one infusion port is coupled to one of the elongated delivery device, the infusion array, the first infusion member or the second infusion member.

**16 Claims, 42 Drawing Sheets**



U.S. PATENT DOCUMENTS

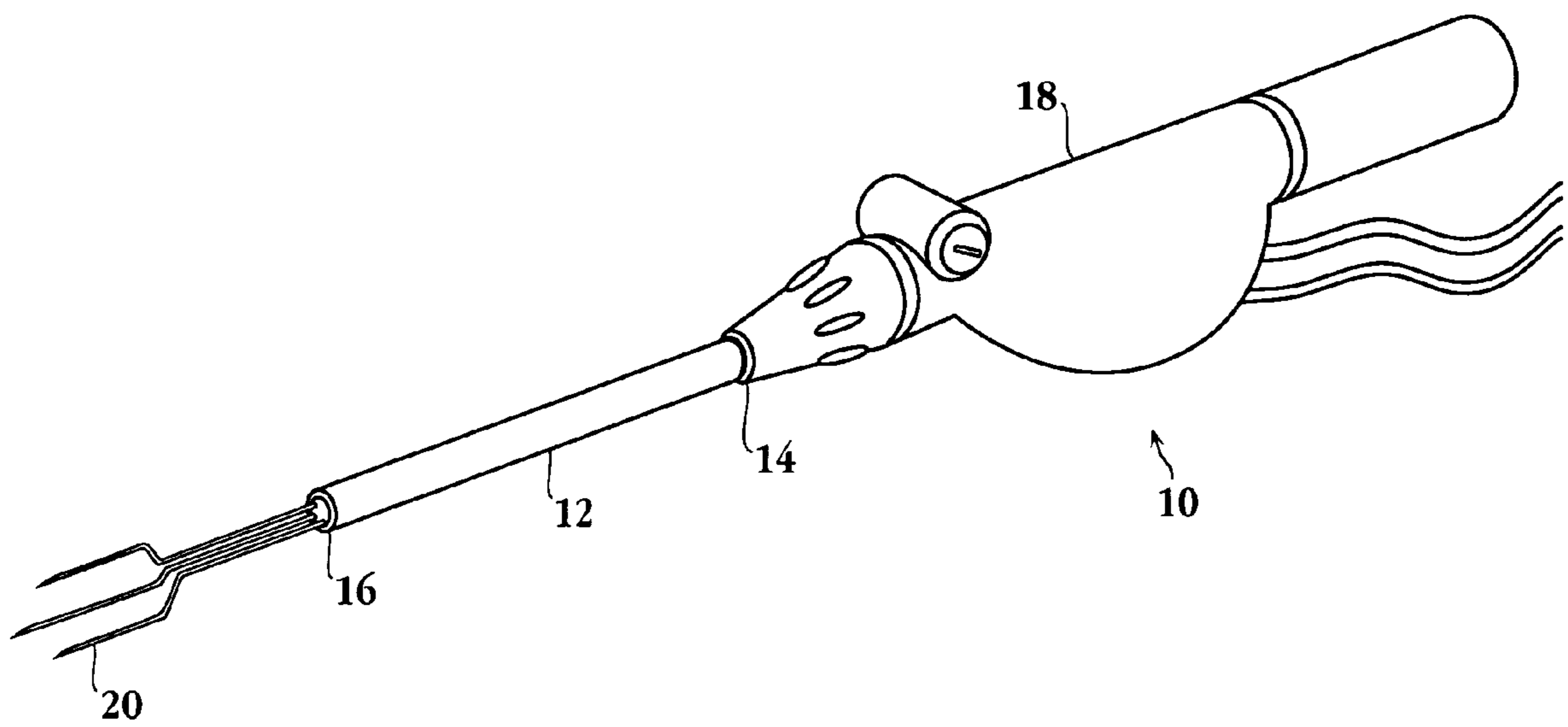
5,007,908 A \* 4/1991 Rydell ..... 606/47  
 5,122,137 A 6/1992 Lennox  
 5,122,138 A 6/1992 Manwaring  
 5,165,421 A 11/1992 Fleischhacker  
 5,246,014 A 9/1993 Williams  
 5,254,117 A 10/1993 Rigby et al.  
 5,281,218 A 1/1994 Imran  
 5,314,466 A 5/1994 Stern et al.  
 5,322,503 A 6/1994 Desai  
 5,328,467 A 7/1994 Edwards et al.  
 5,334,193 A \* 8/1994 Nardella ..... 606/41  
 5,334,206 A 8/1994 Daikuzono  
 5,336,178 A 8/1994 Kaplan et al.  
 5,336,222 A 8/1994 Durgin, Jr. et al.  
 5,342,357 A 8/1994 Nardella  
 5,370,675 A \* 12/1994 Edwards et al. .... 607/101  
 5,383,876 A 1/1995 Nardella  
 5,383,917 A 1/1995 Desai et al.  
 5,403,311 A 4/1995 Abele et al.  
 5,431,649 A 7/1995 Mulier et al.  
 5,433,708 A 7/1995 Nichols et al.  
 5,433,739 A 7/1995 Sluijter et al.  
 5,437,660 A 8/1995 Johnson et al.  
 5,437,662 A 8/1995 Nardella  
 5,454,807 A 10/1995 Lennox et al.  
 5,536,267 A 7/1996 Edwards et al.  
 5,551,426 A 9/1996 Hummel et al.  
 5,556,377 A 9/1996 Rosen et al.  
 5,558,672 A 9/1996 Edwards et al.  
 5,558,673 A 9/1996 Edwards et al.  
 5,560,358 A 10/1996 Arnold et al.  
 5,562,703 A 10/1996 Desai  
 5,599,345 A 2/1997 Edwards et al.  
 5,599,346 A 2/1997 Edwards et al.  
 5,605,539 A 2/1997 Buelna et al.  
 5,609,151 A 3/1997 Mulier et al.  
 5,620,481 A 4/1997 Desai et al.

5,697,909 A 12/1997 Eggers et al.  
 5,725,524 A 3/1998 Mulier et al.  
 5,735,811 A 4/1998 Brisken  
 5,800,482 A 9/1998 Pomeranz et al.  
 5,807,395 A 9/1998 Mulier et al.  
 5,827,276 A 10/1998 LeVeen et al.  
 5,855,576 A 1/1999 LeVeen et al.  
 5,868,740 A 2/1999 LeVeen et al.  
 5,876,398 A 3/1999 Mulier et al.  
 5,879,349 A 3/1999 Edwards  
 5,888,198 A 3/1999 Eggers et al.  
 5,891,095 A 4/1999 Eggers et al.  
 5,897,553 A 4/1999 Mulier et al.  
 5,902,328 A 5/1999 LaFontaine et al.  
 5,906,613 A 5/1999 Mulier et al.  
 5,913,854 A 6/1999 Maguire et al.  
 5,913,856 A 6/1999 Chia et al.  
 5,971,968 A 10/1999 Tu et al.  
 5,997,532 A 12/1999 McLaughlin et al.  
 6,013,074 A 1/2000 Taylor  
 6,015,407 A 1/2000 Rieb et al.  
 6,016,809 A 1/2000 Mulier et al.  
 6,024,739 A 2/2000 Ponzi et al.  
 6,030,379 A 2/2000 Panescu et al.  
 6,032,077 A 2/2000 Pomeranz  
 6,056,747 A 5/2000 Saadat et al.  
 6,063,081 A 5/2000 Mulier et al.  
 6,086,585 A 7/2000 Hovda et al.  
 6,129,726 A 10/2000 Edwards et al.  
 6,131,577 A 10/2000 Nicholson  
 6,238,393 B1 5/2001 Mulier et al.

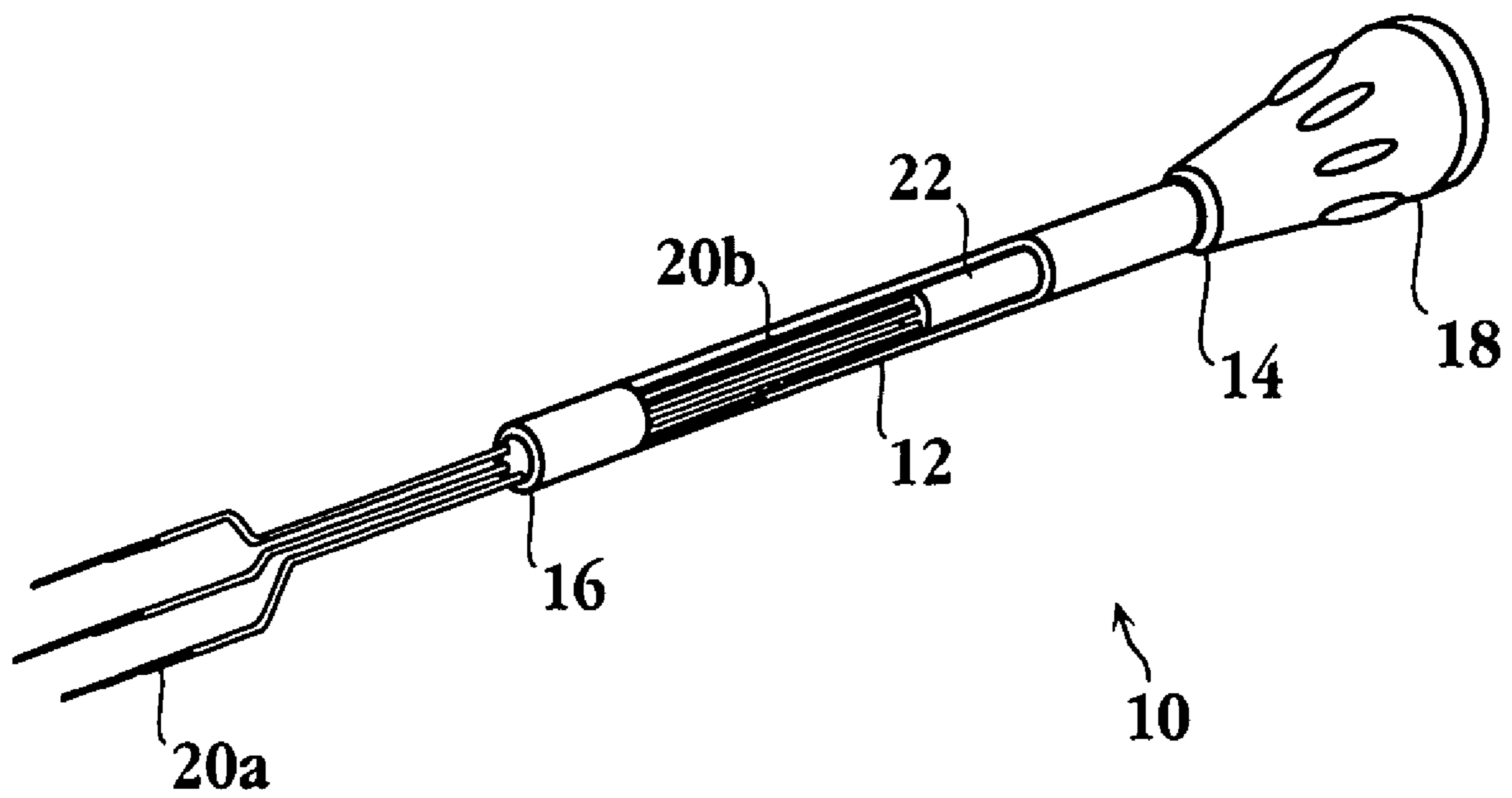
FOREIGN PATENT DOCUMENTS

WO PCT/BE99/00106 2/2000  
 WO PCT/BE99/00107 2/2000

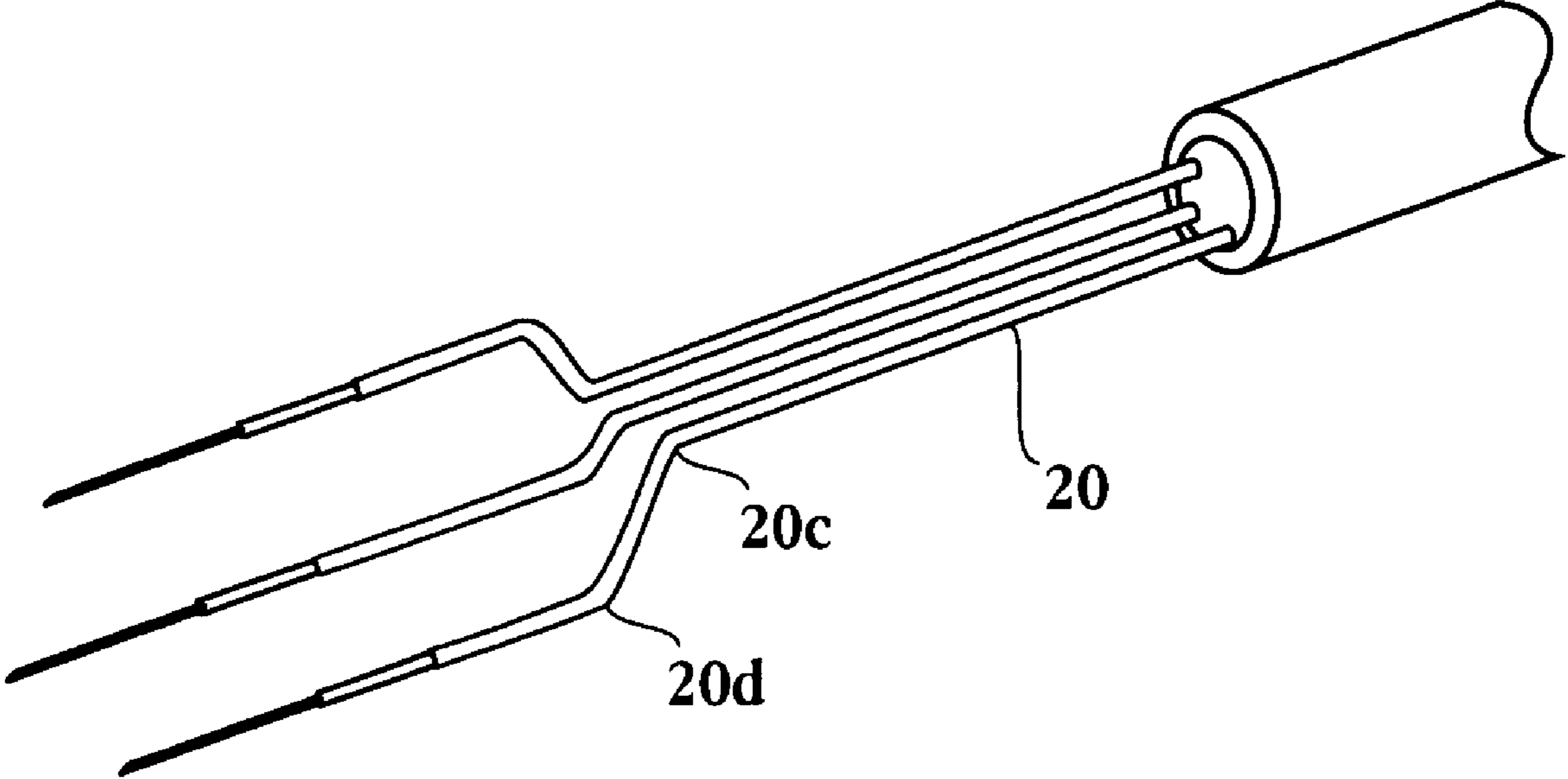
\* cited by examiner



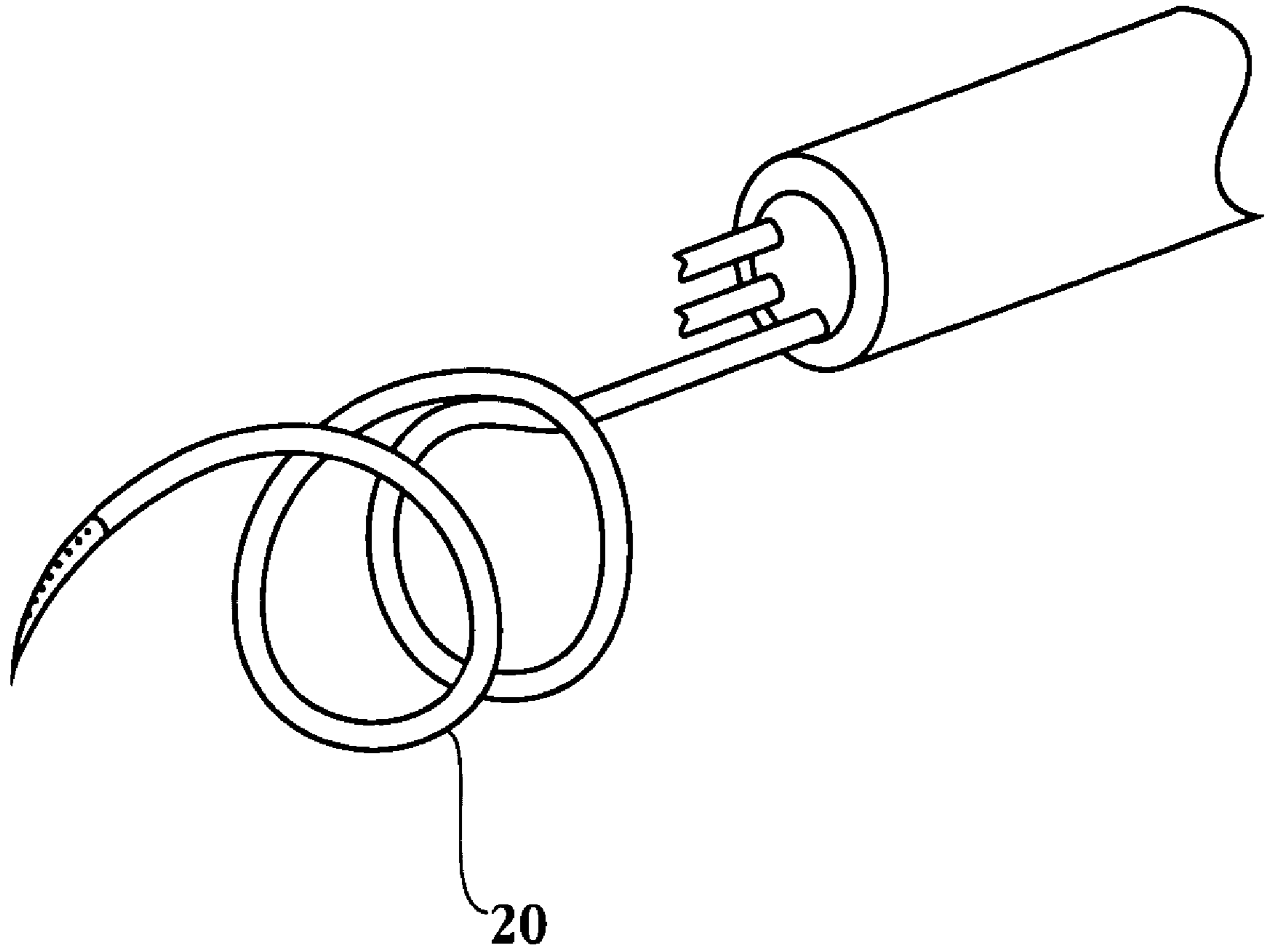
**Fig. 1**



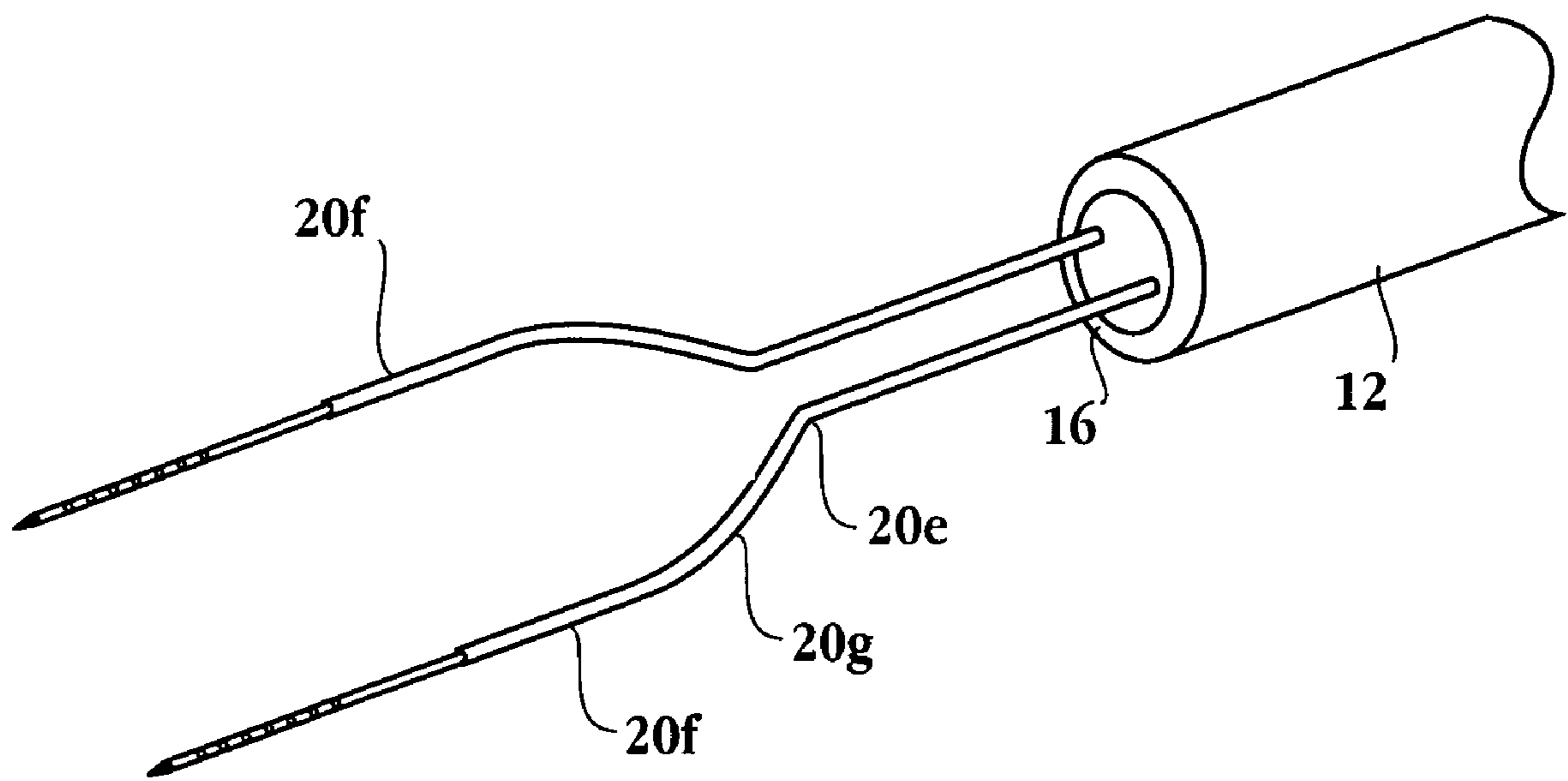
**Fig. 2**



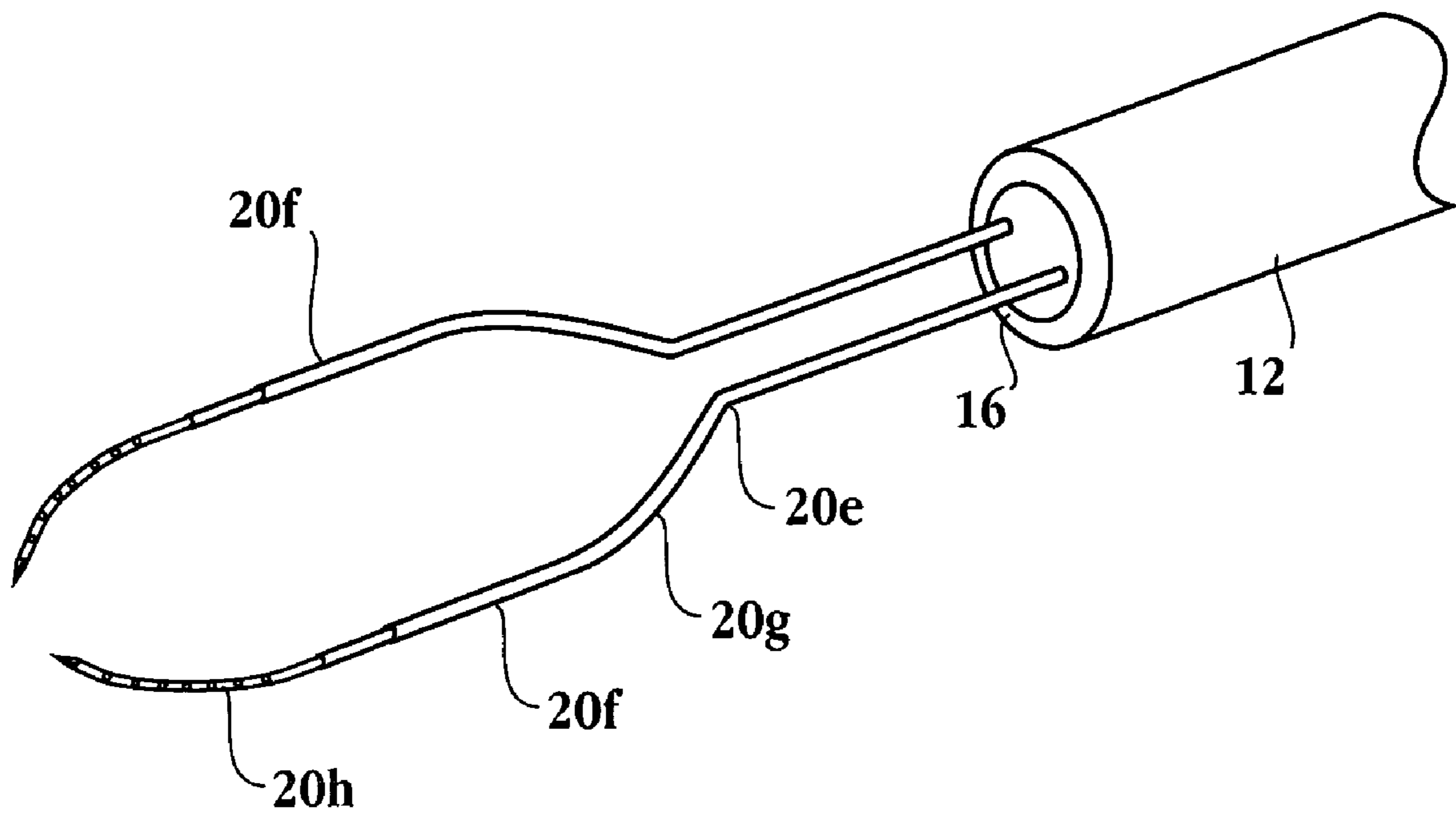
**Fig. 3**



**Fig. 4**

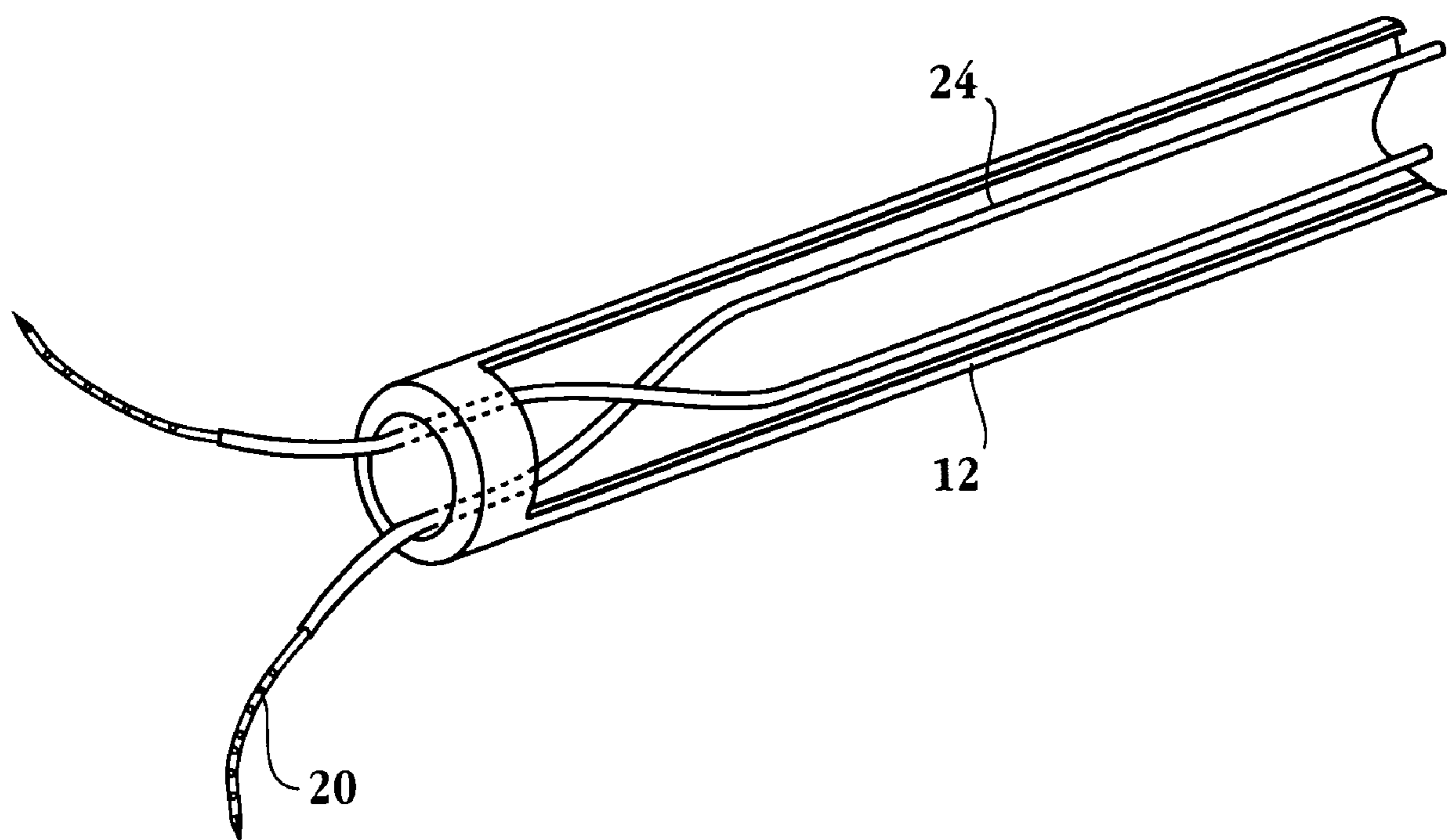


**Fig. 5**

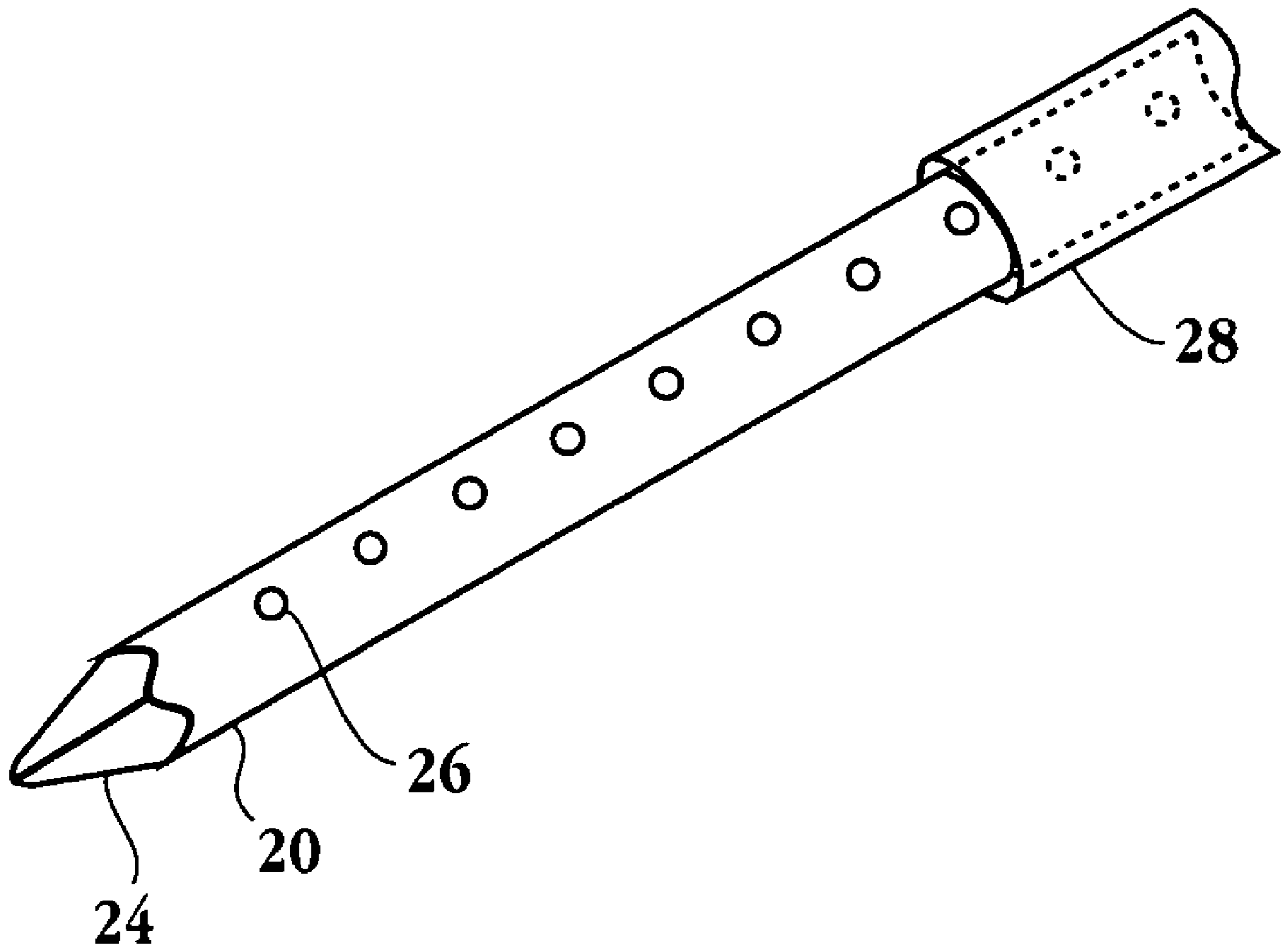


**Fig. 6**

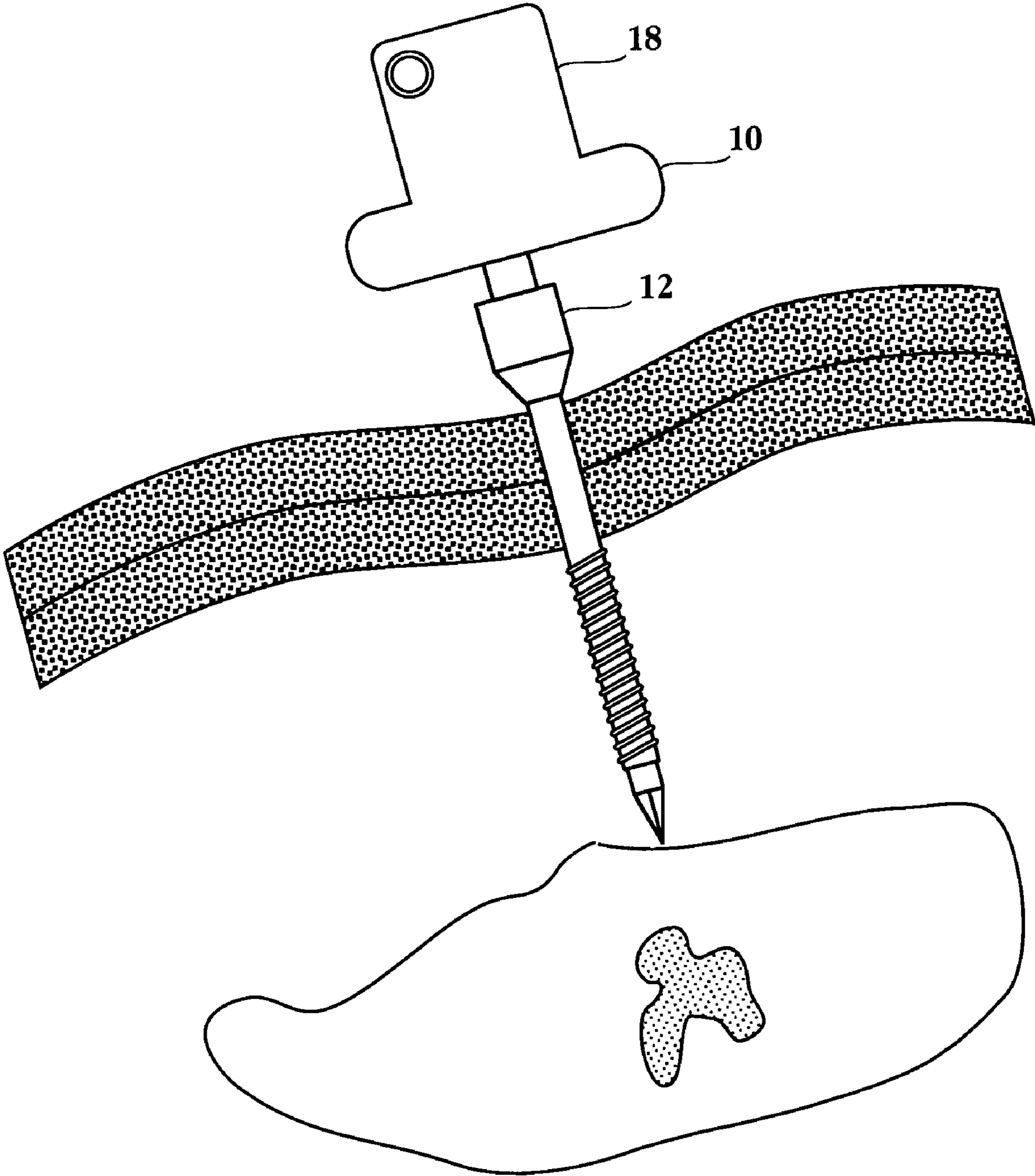




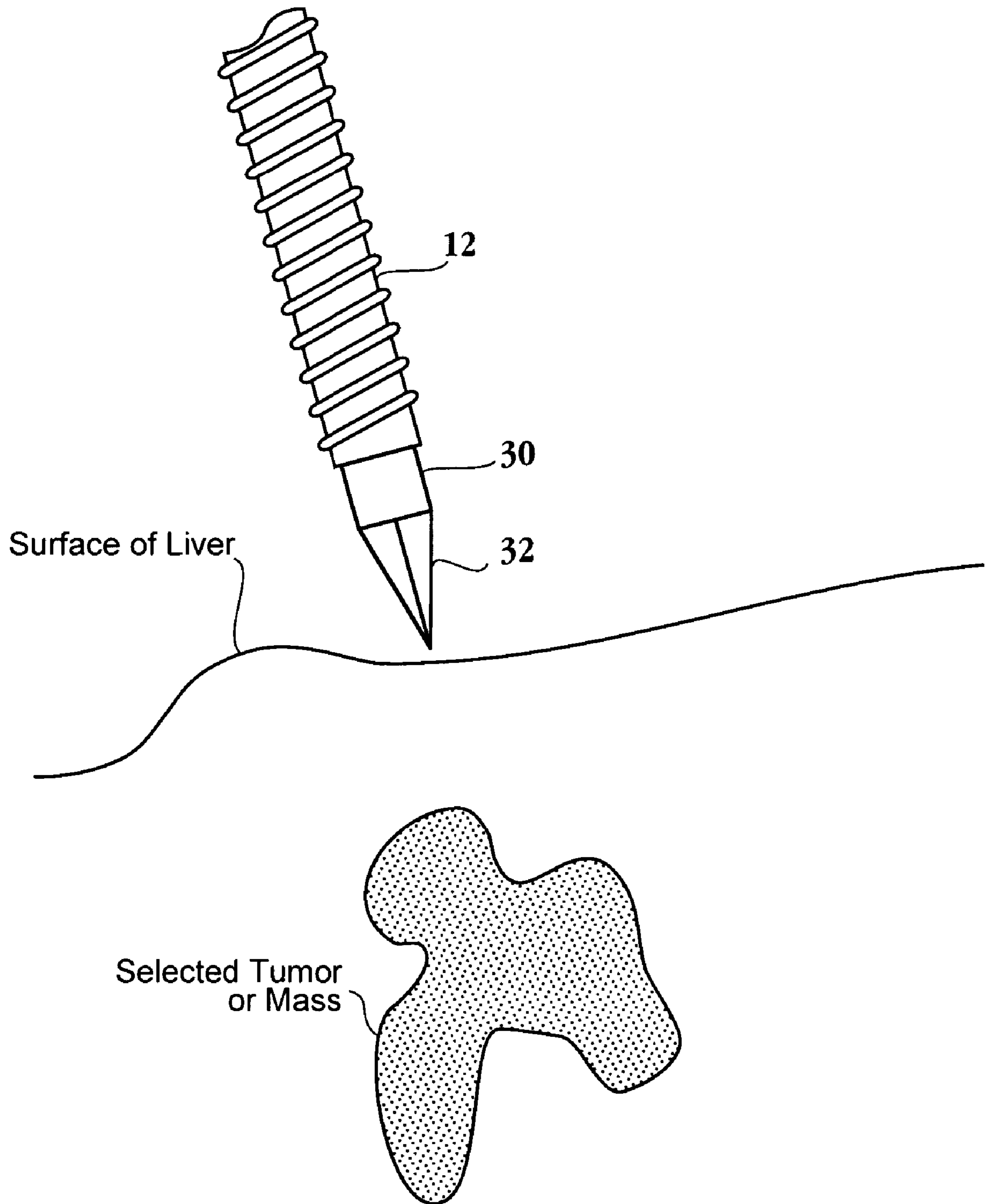
**Fig. 7**



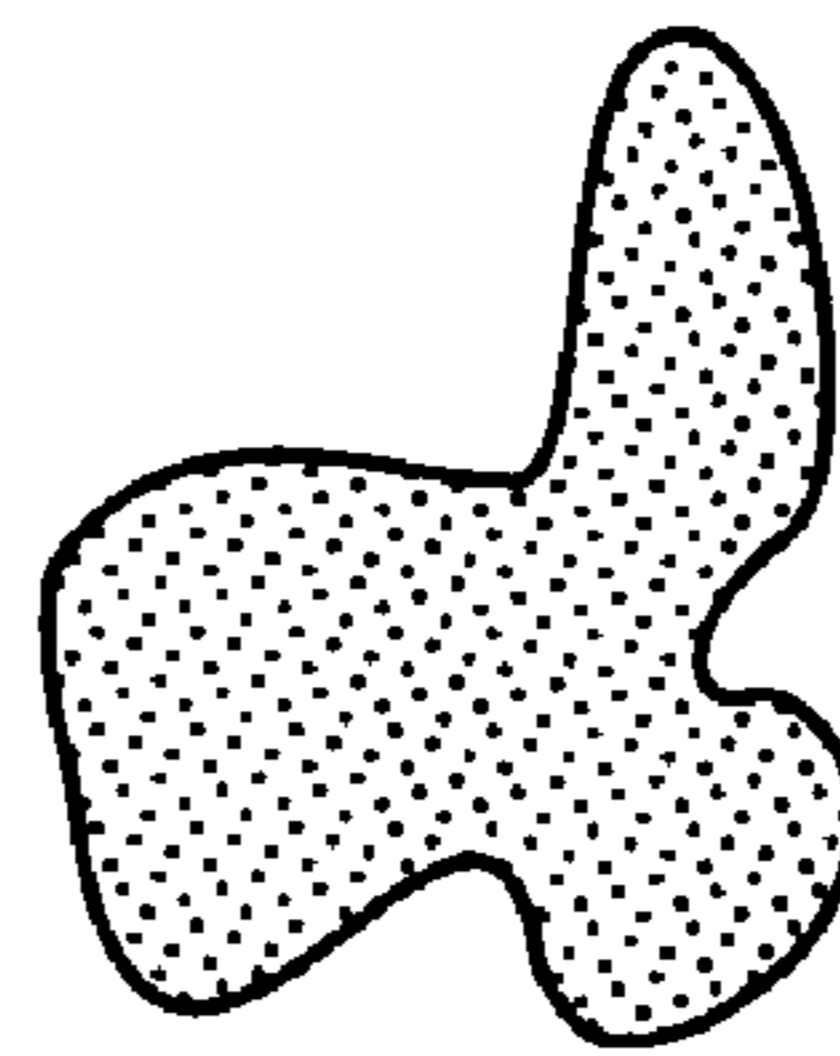
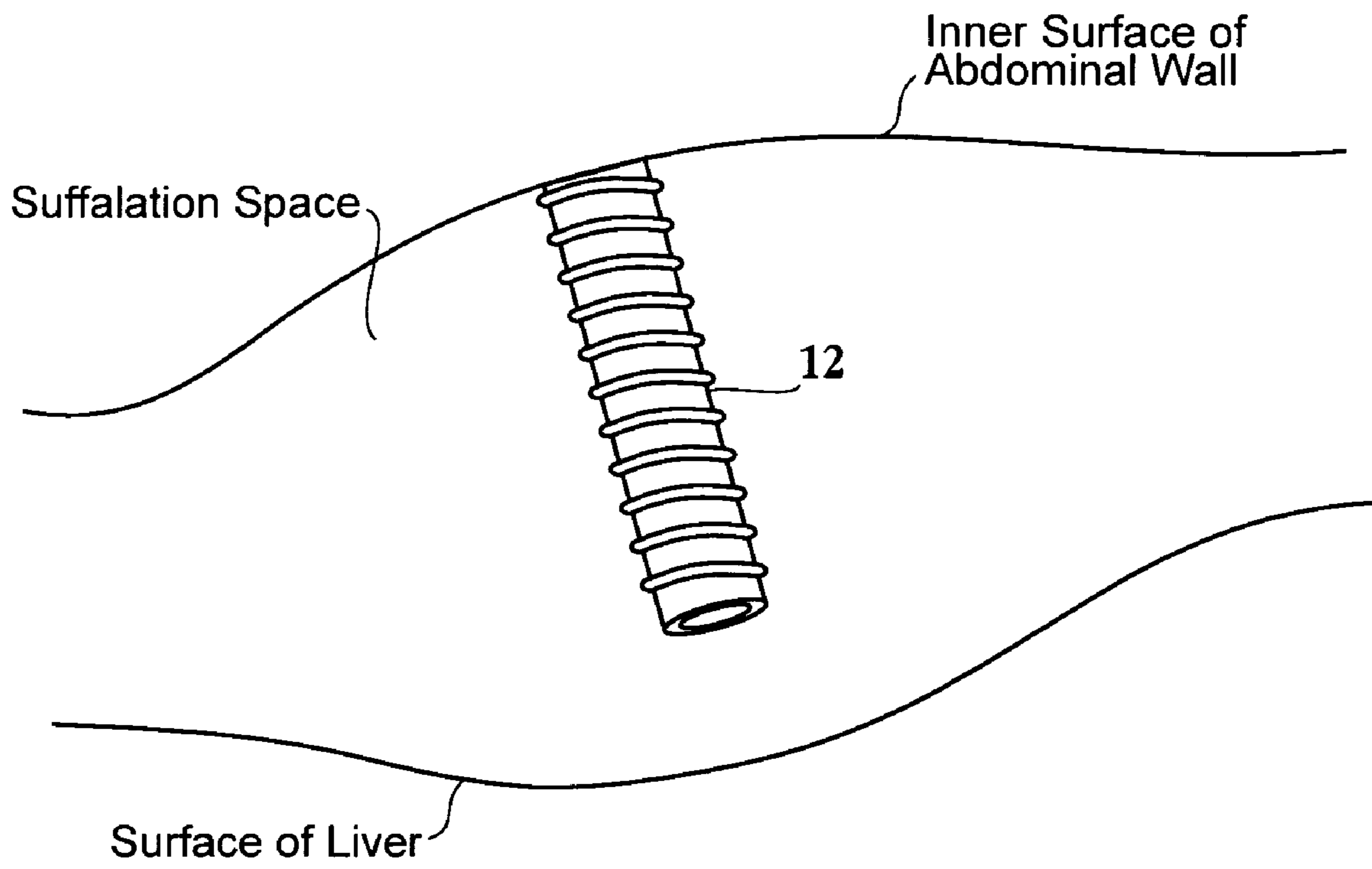
**Fig. 8**



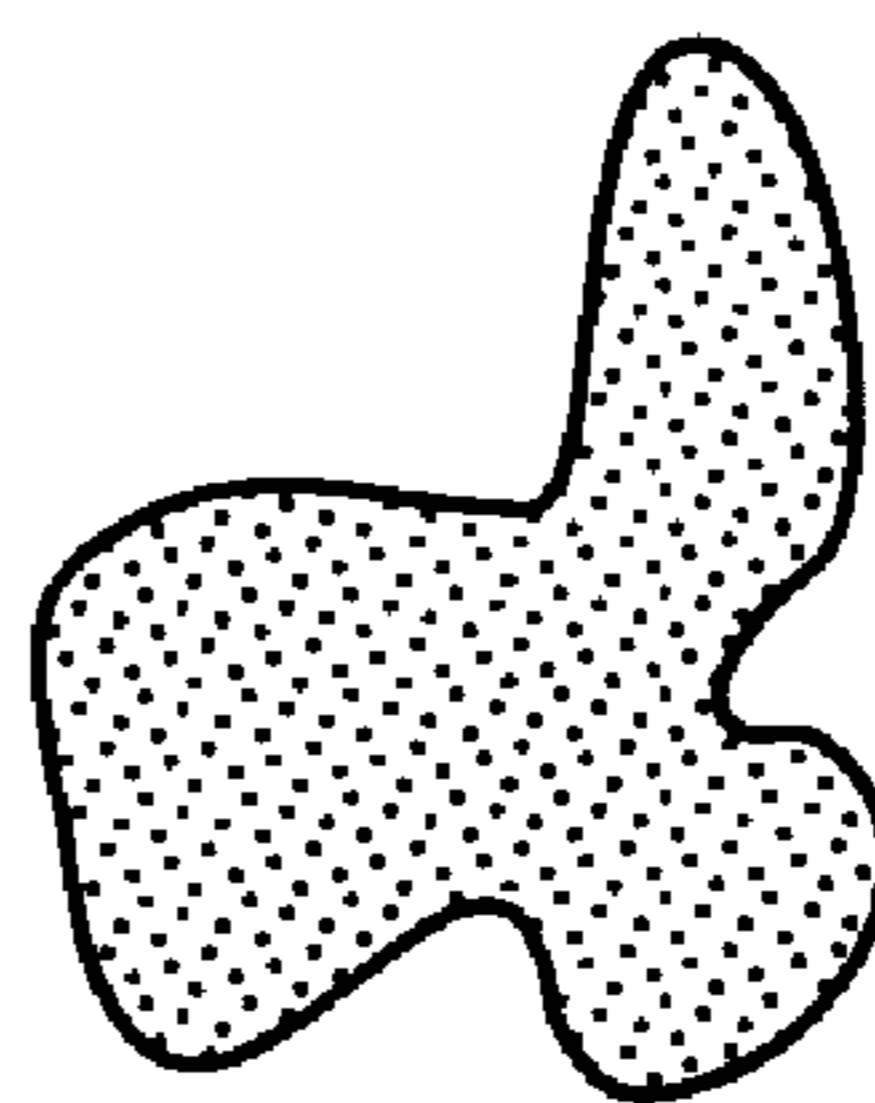
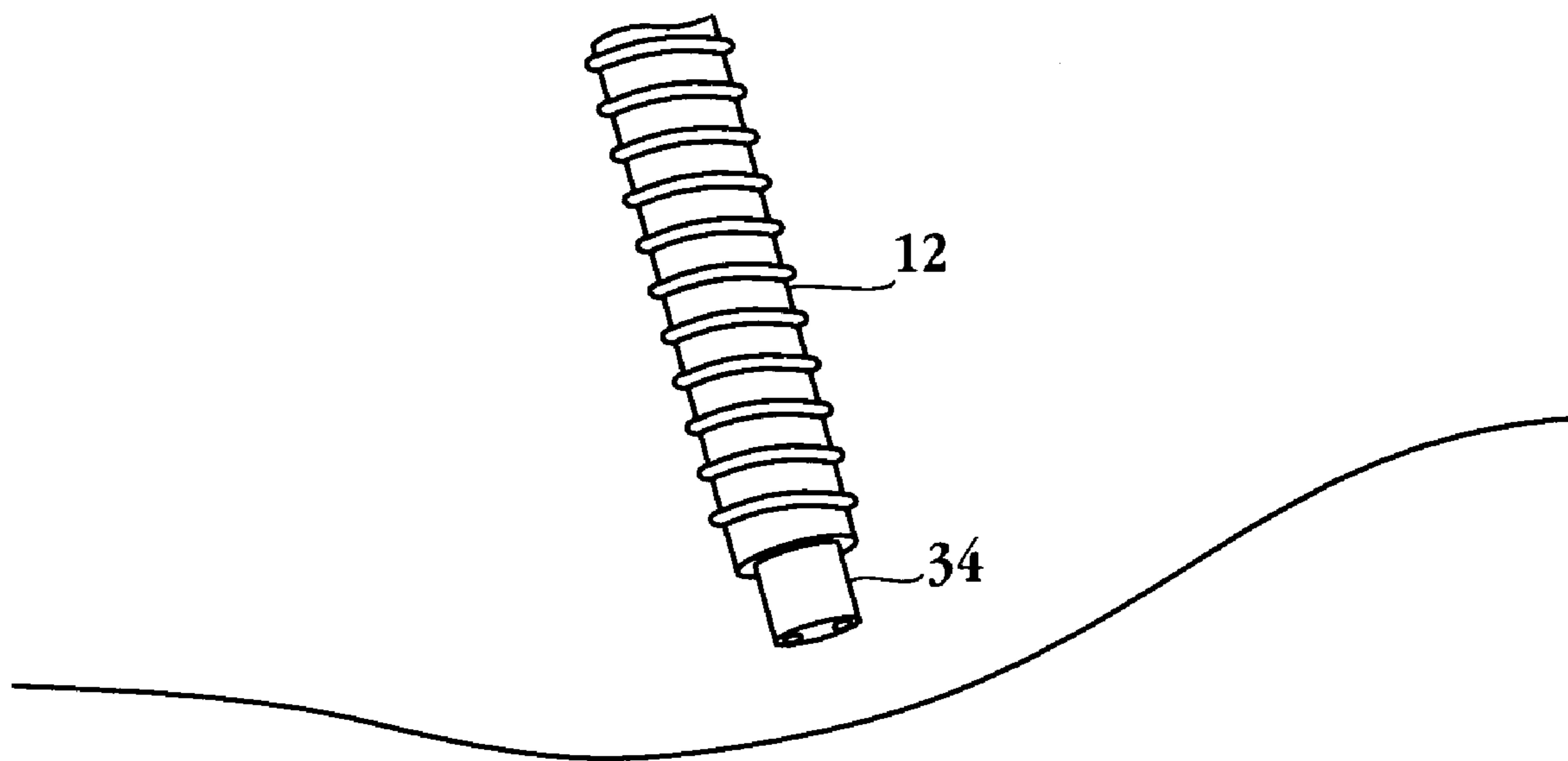
**Fig. 9**



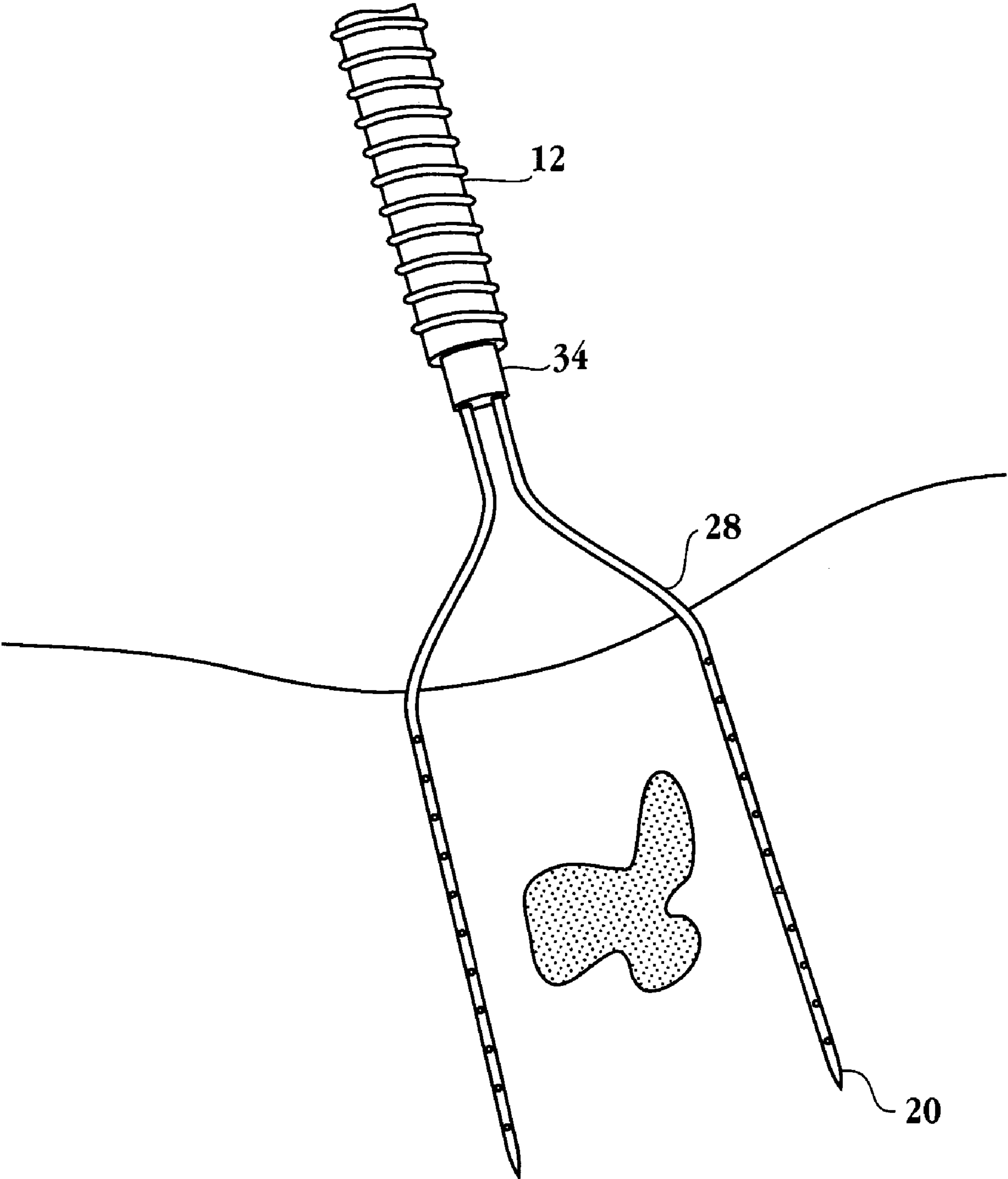
**Fig. 10**



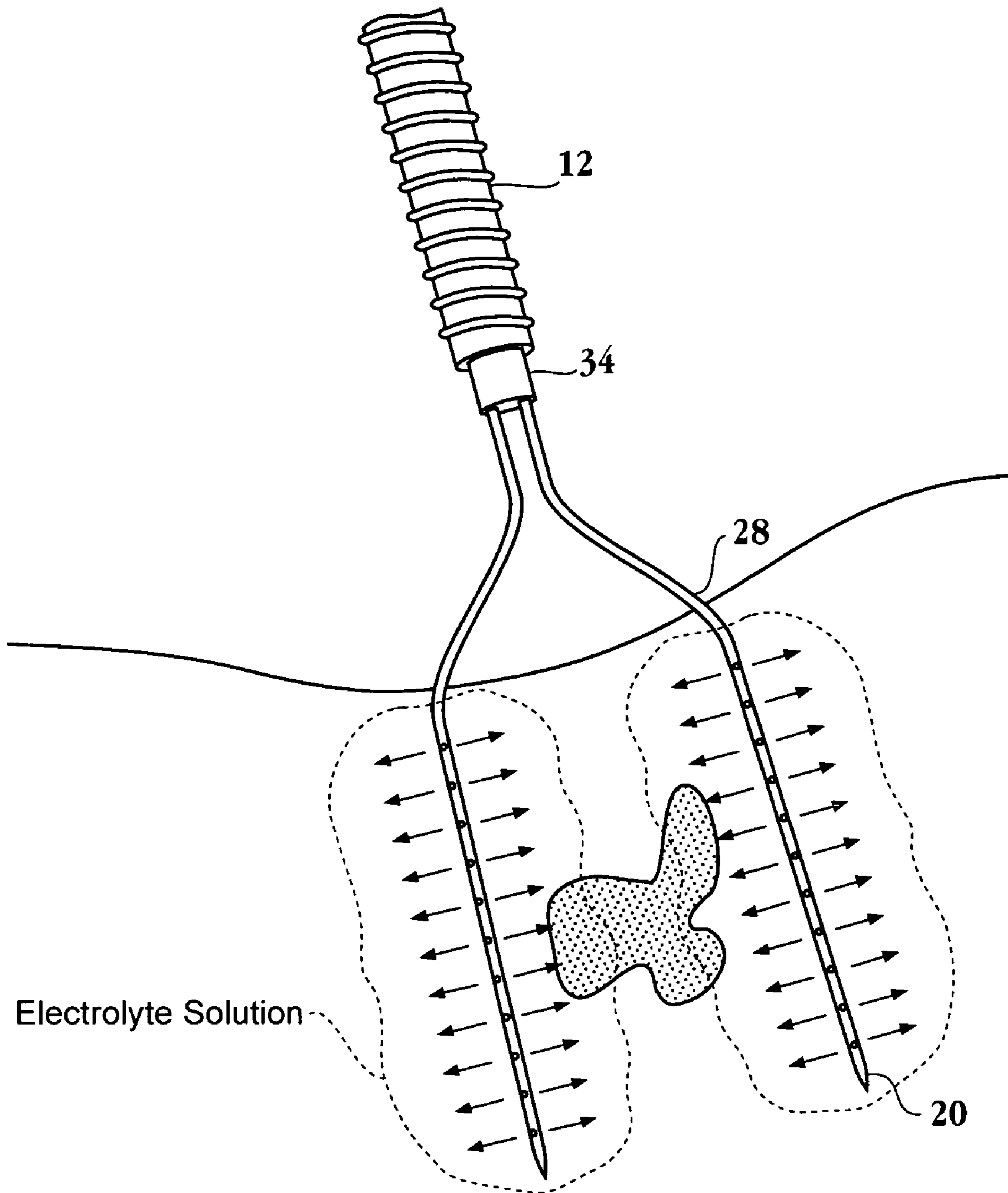
**Fig. 11**



**Fig. 12**

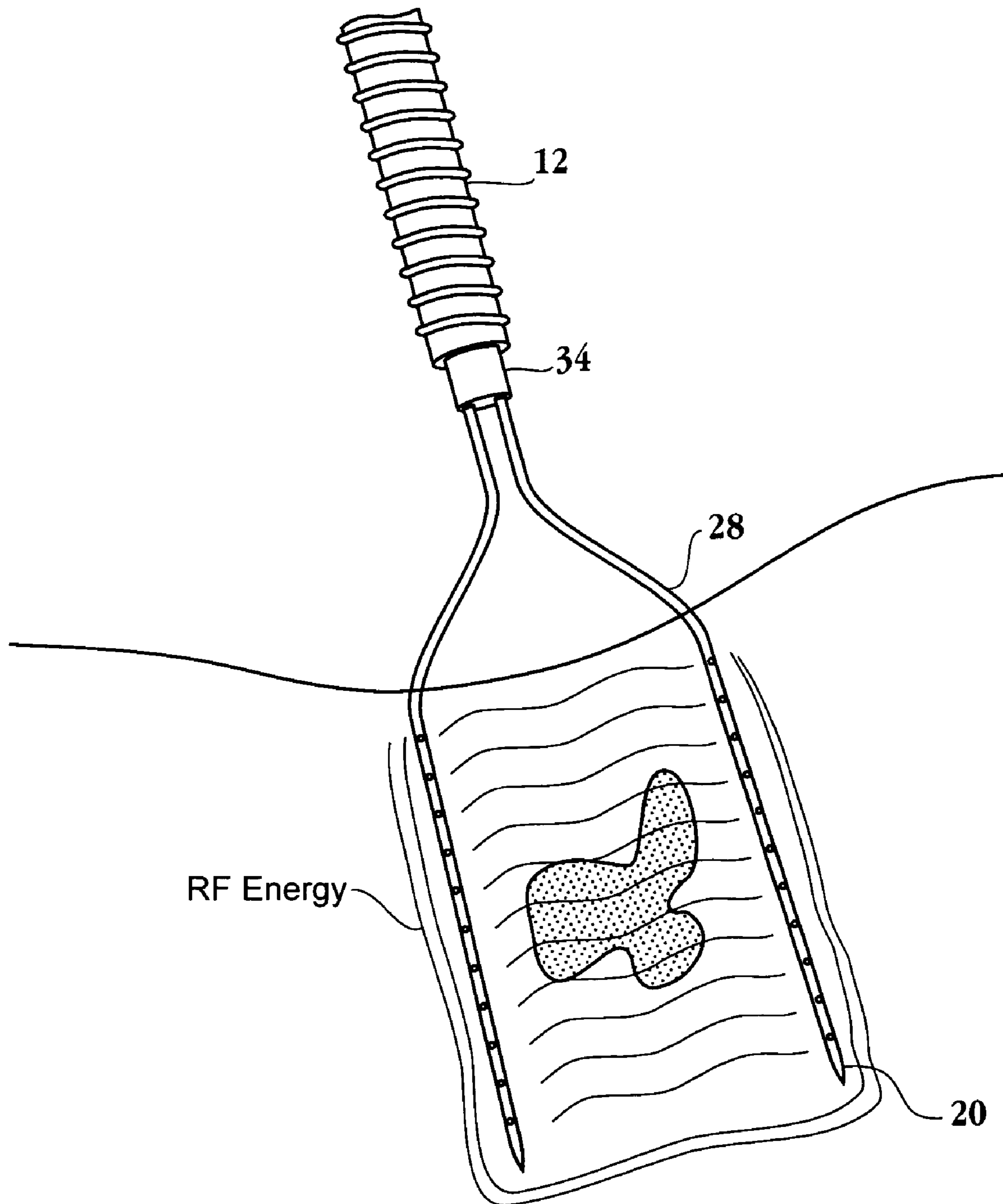


**Fig. 13**

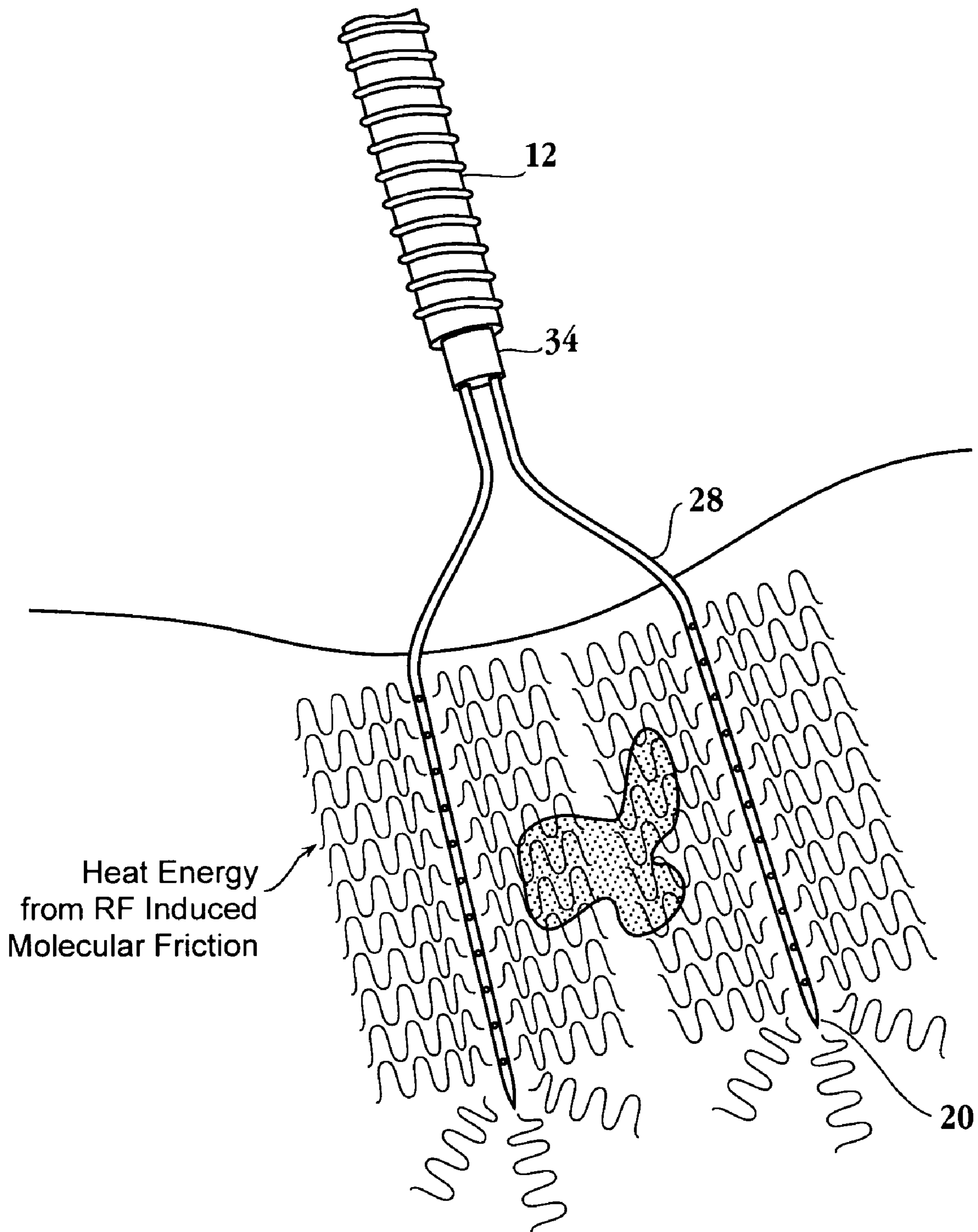


**Fig. 14**

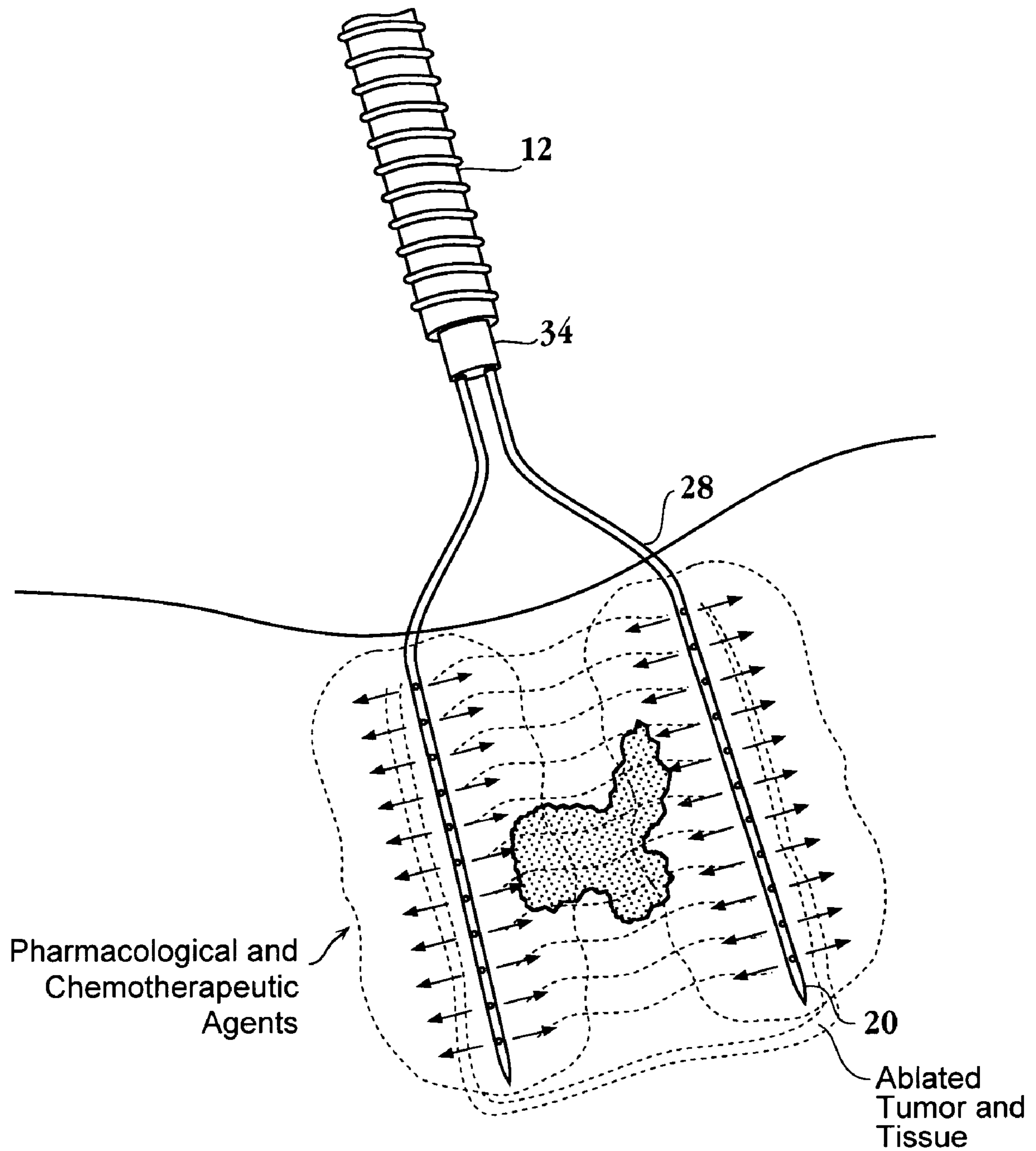




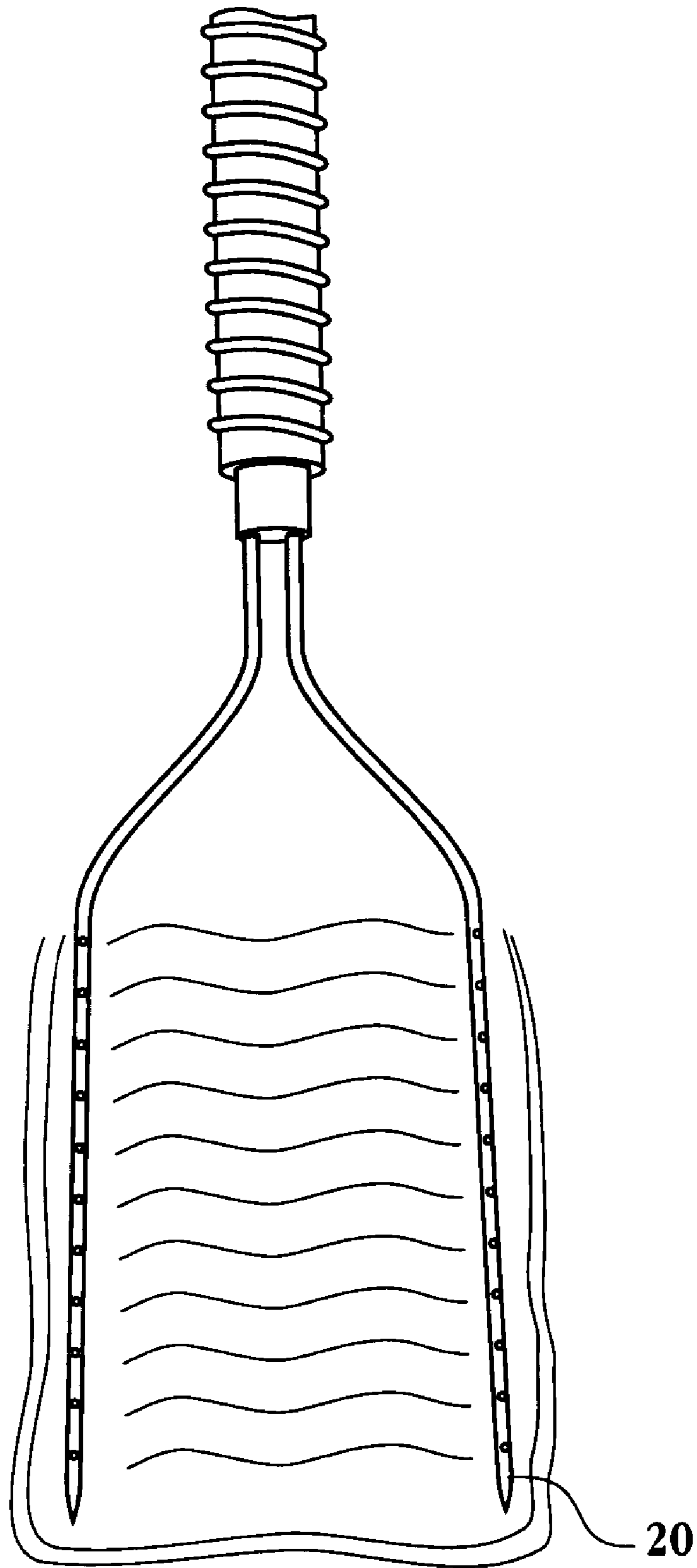
**Fig. 15**



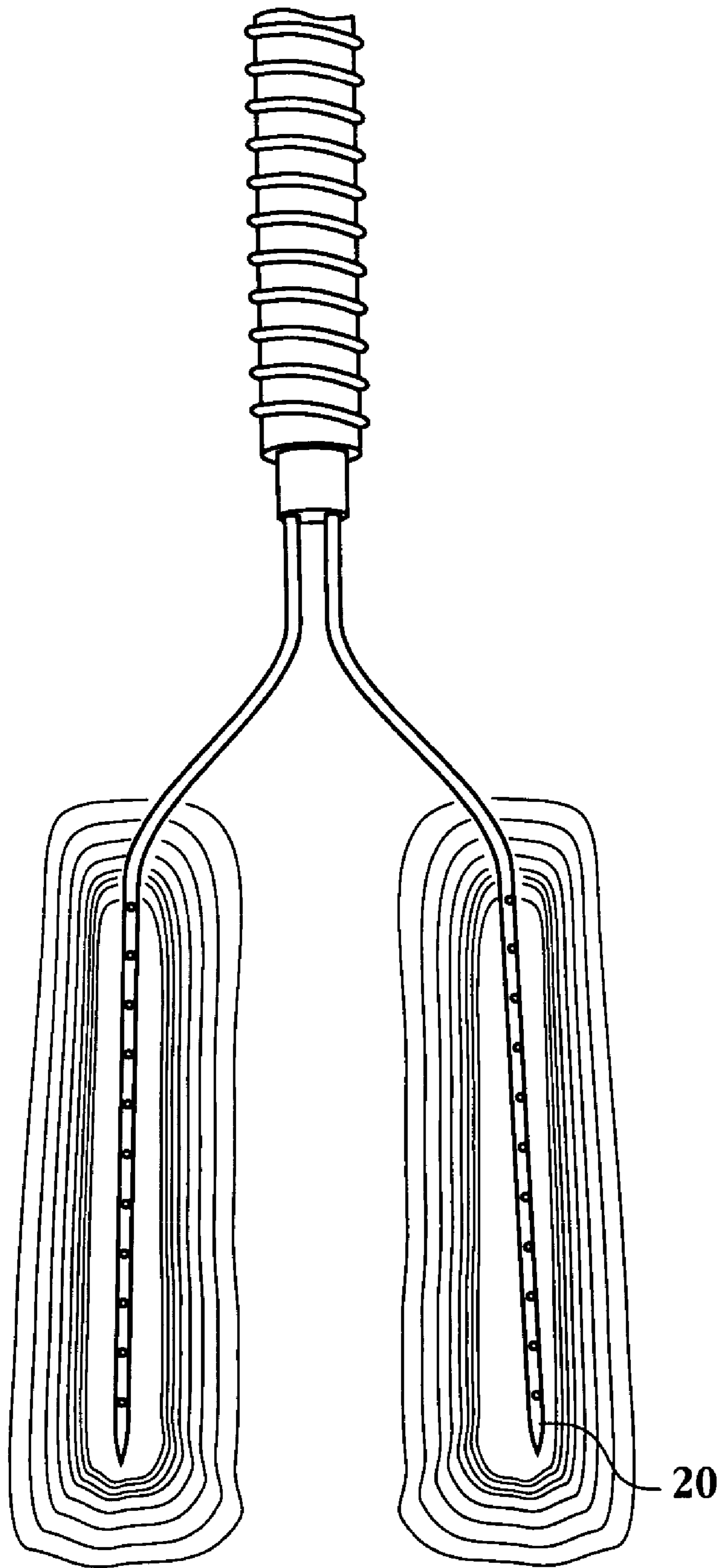
**Fig. 16**



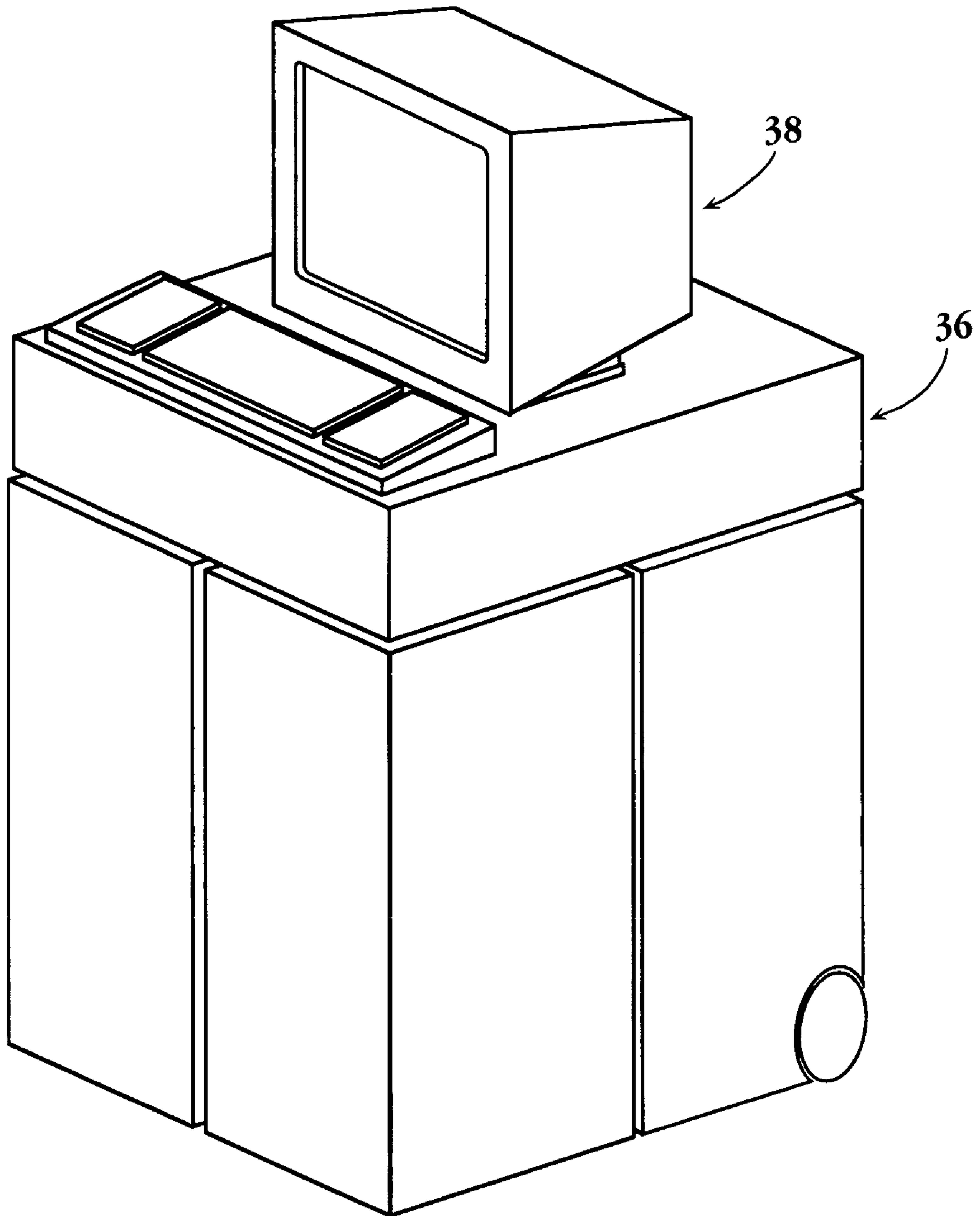
**Fig. 17**



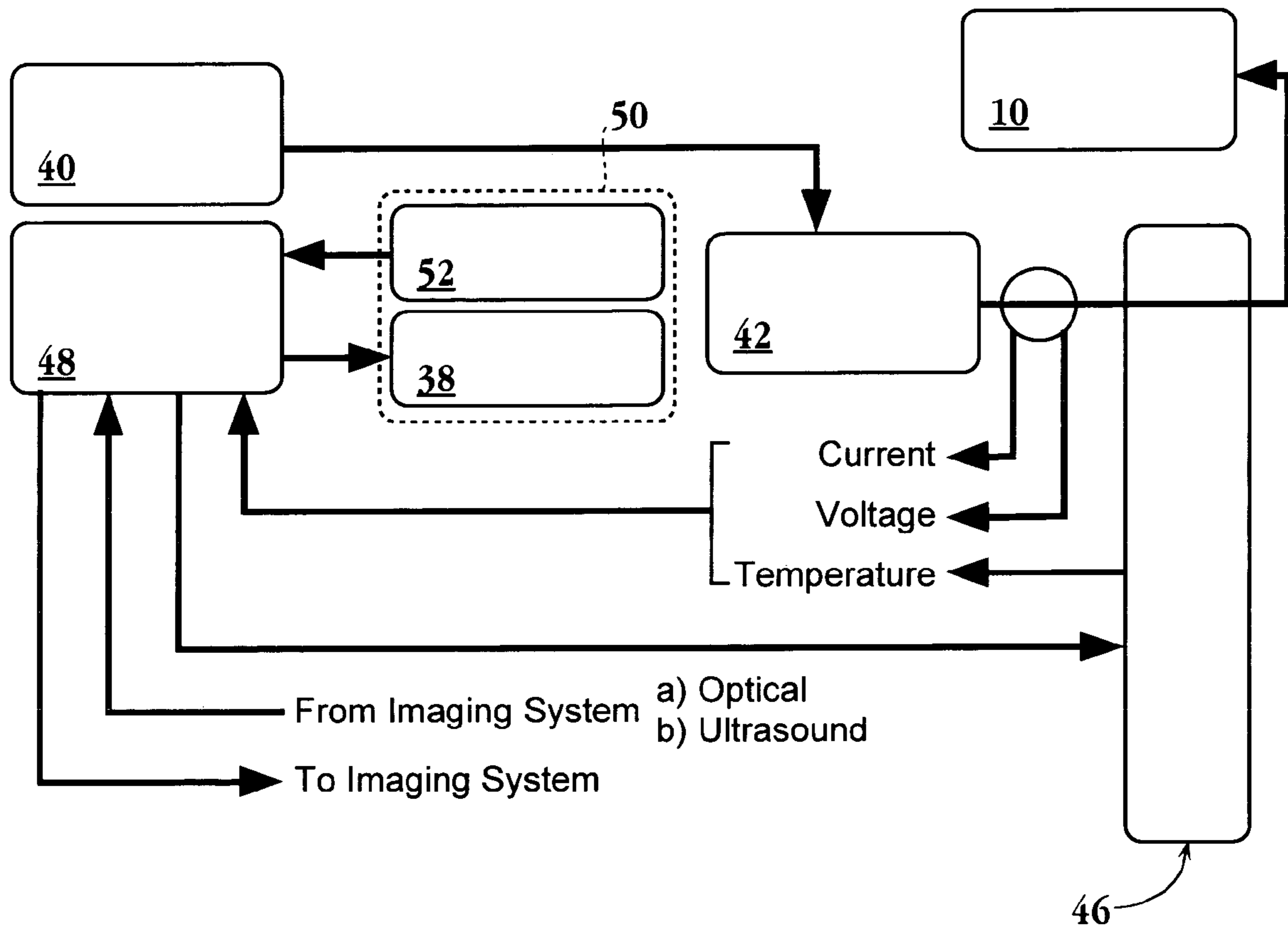
**Fig. 18**



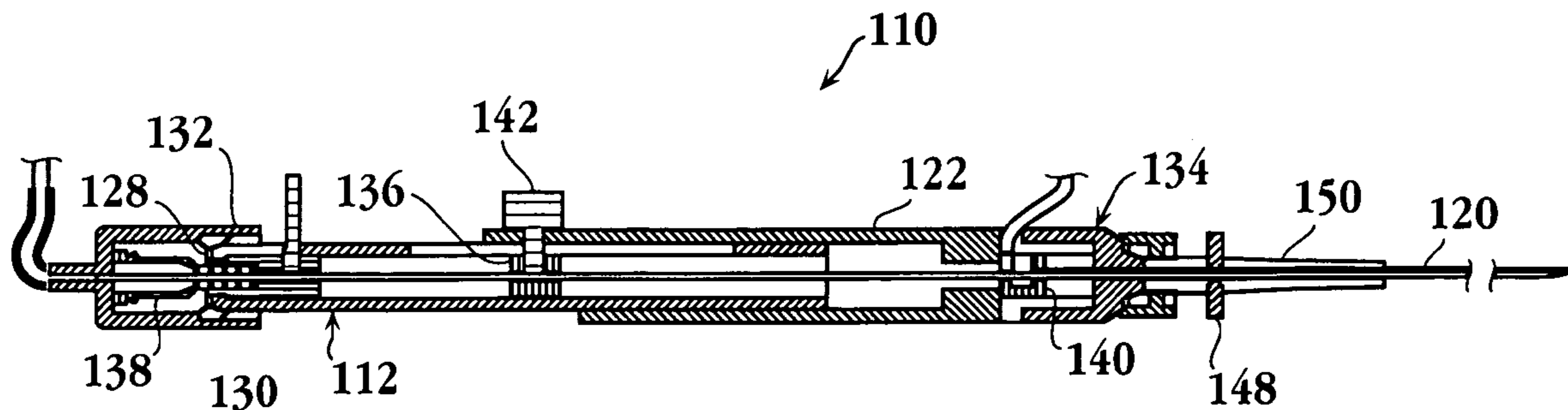
**Fig. 19**



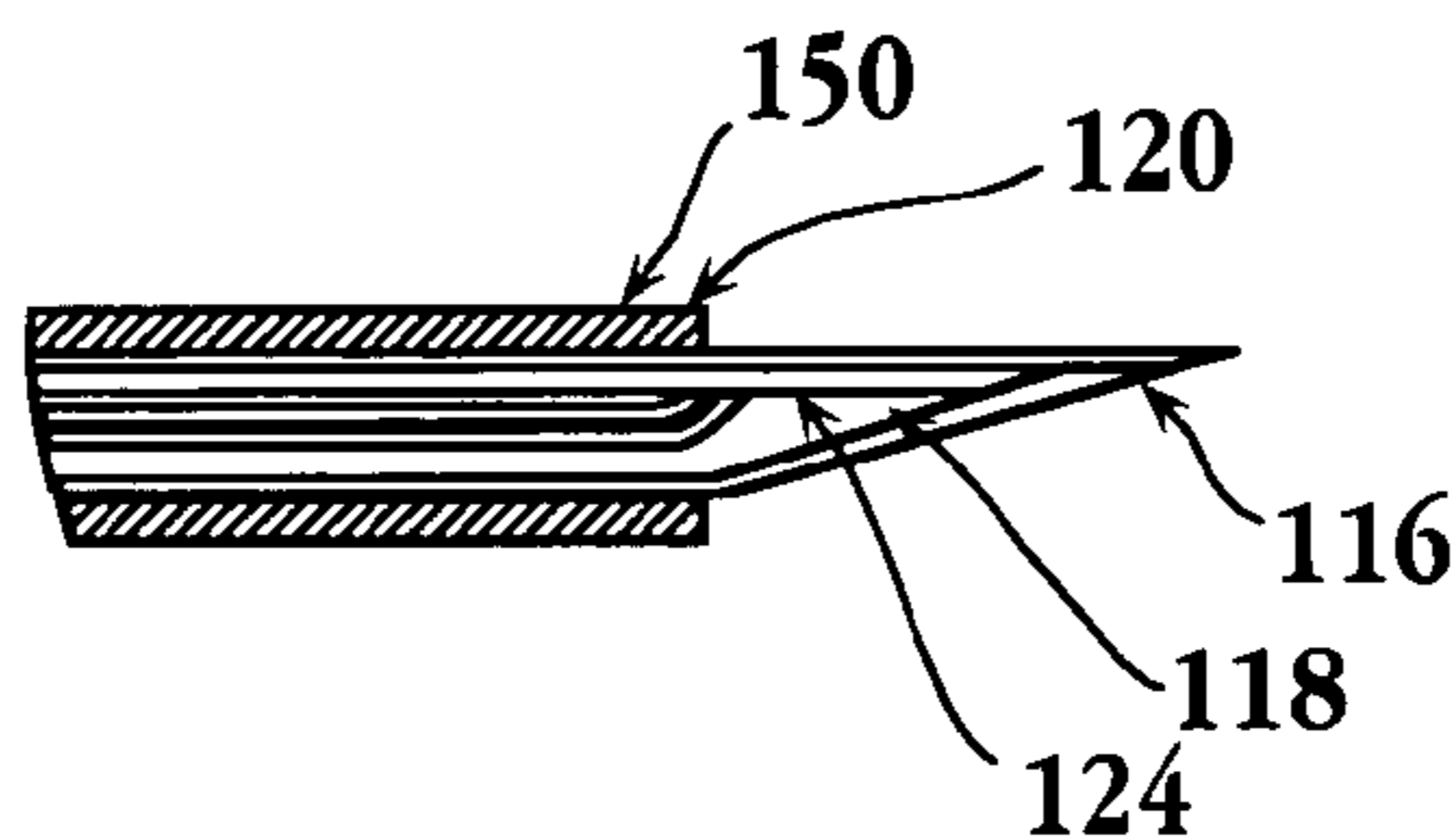
**Fig. 20**



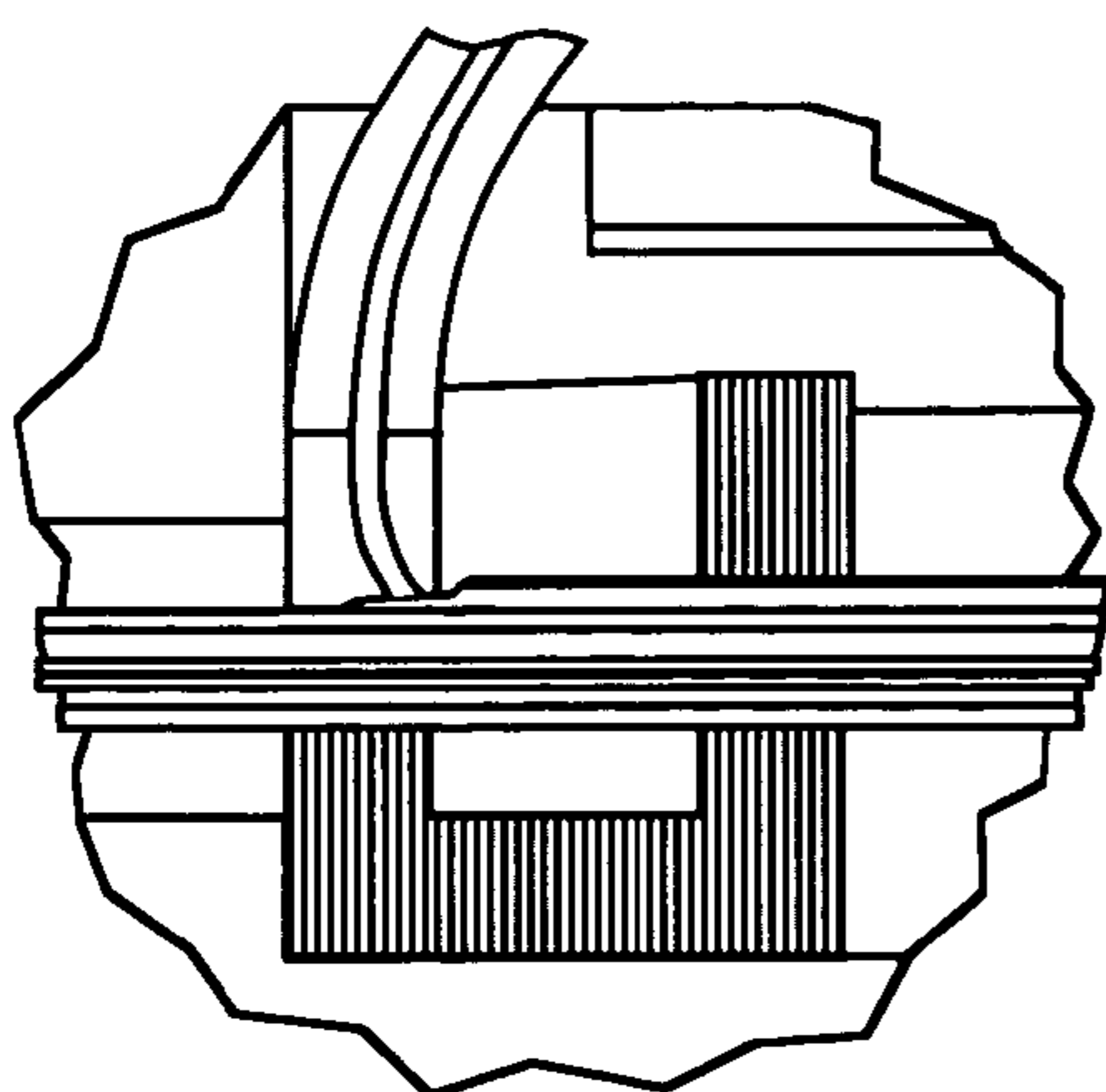
**Fig. 21**



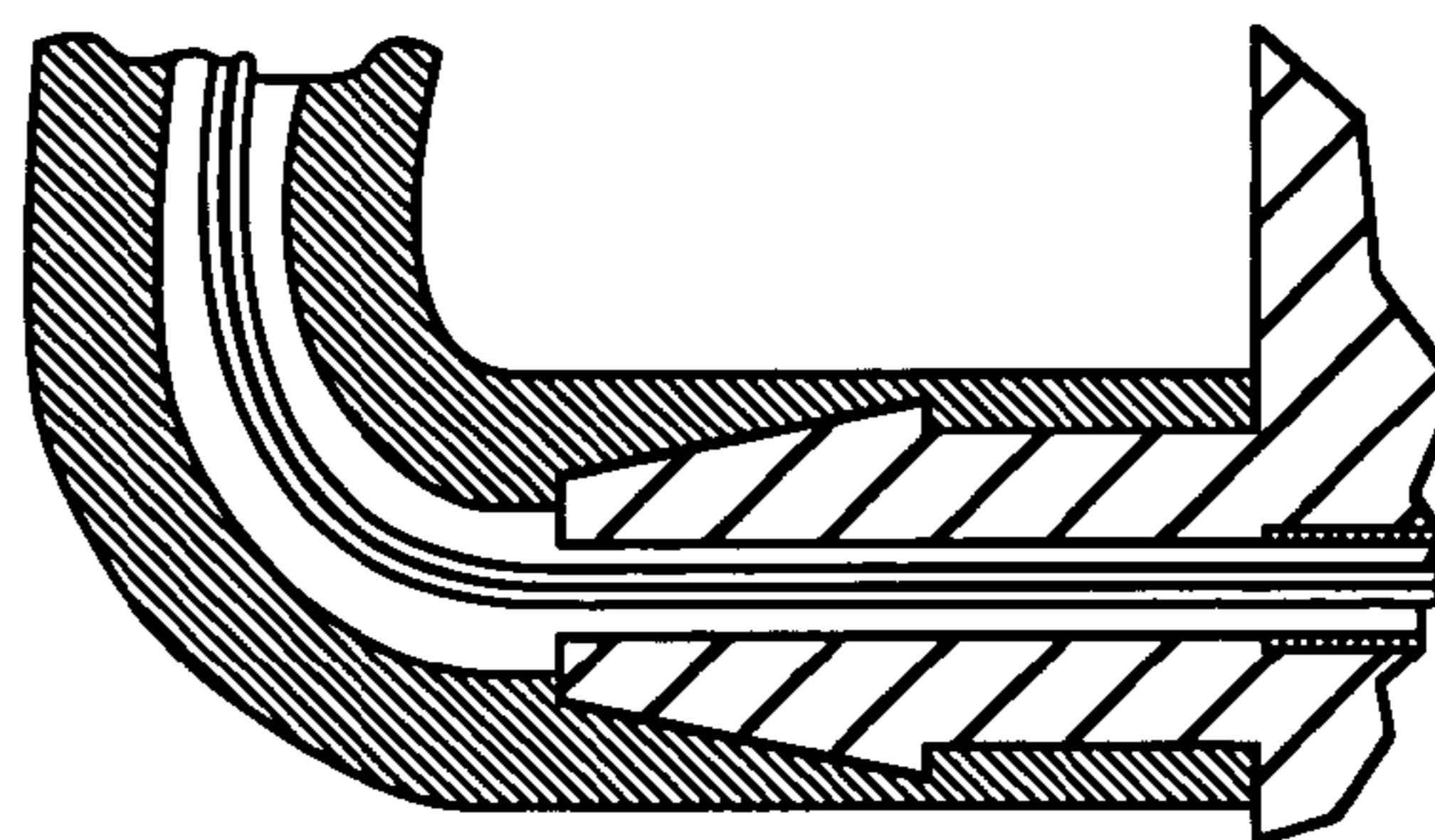
**Fig. 22A**



**Fig. 22B**



**Fig. 22C**



**Fig. 22D**



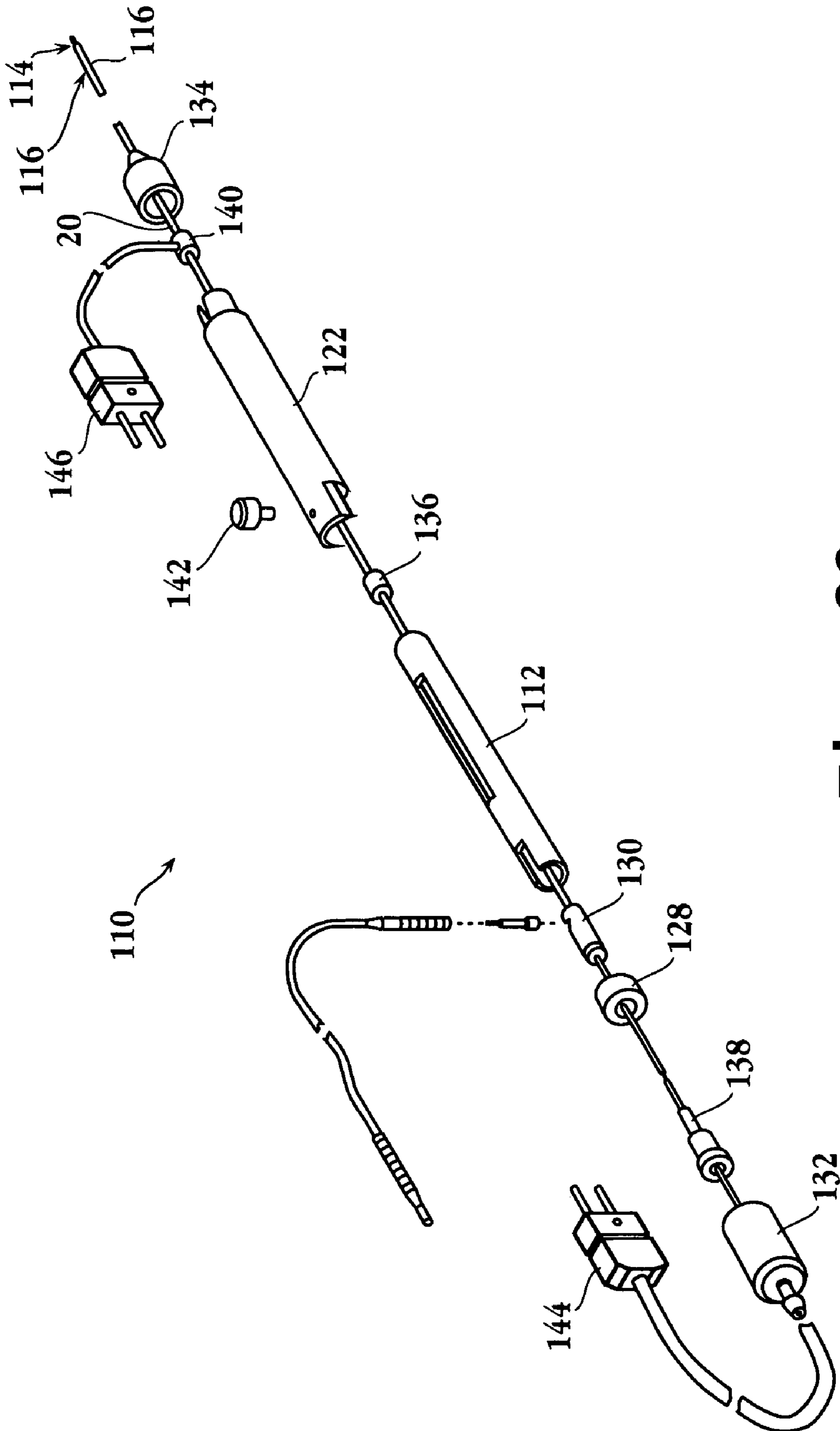
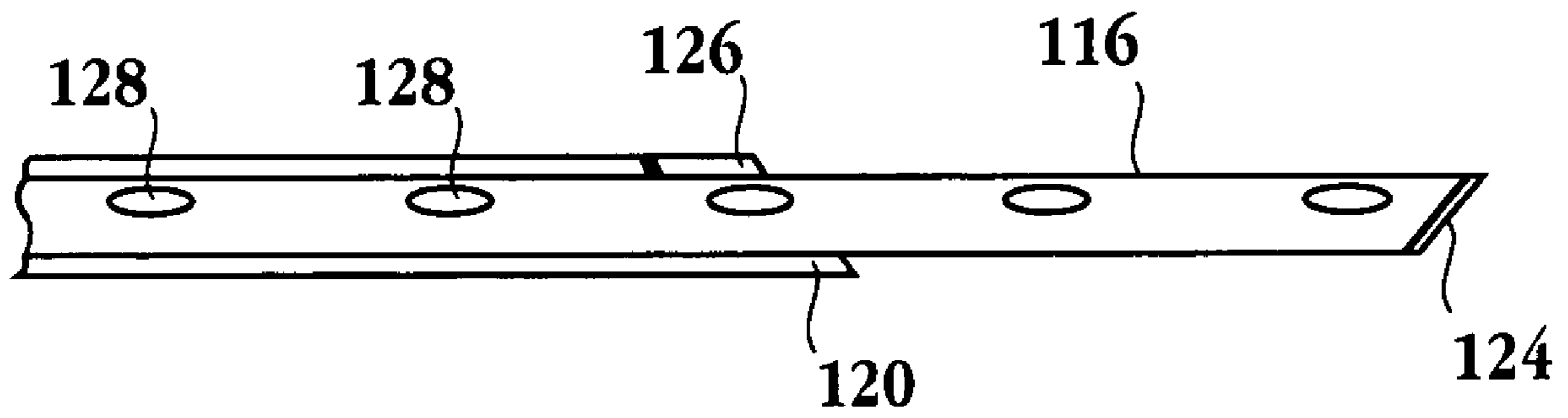
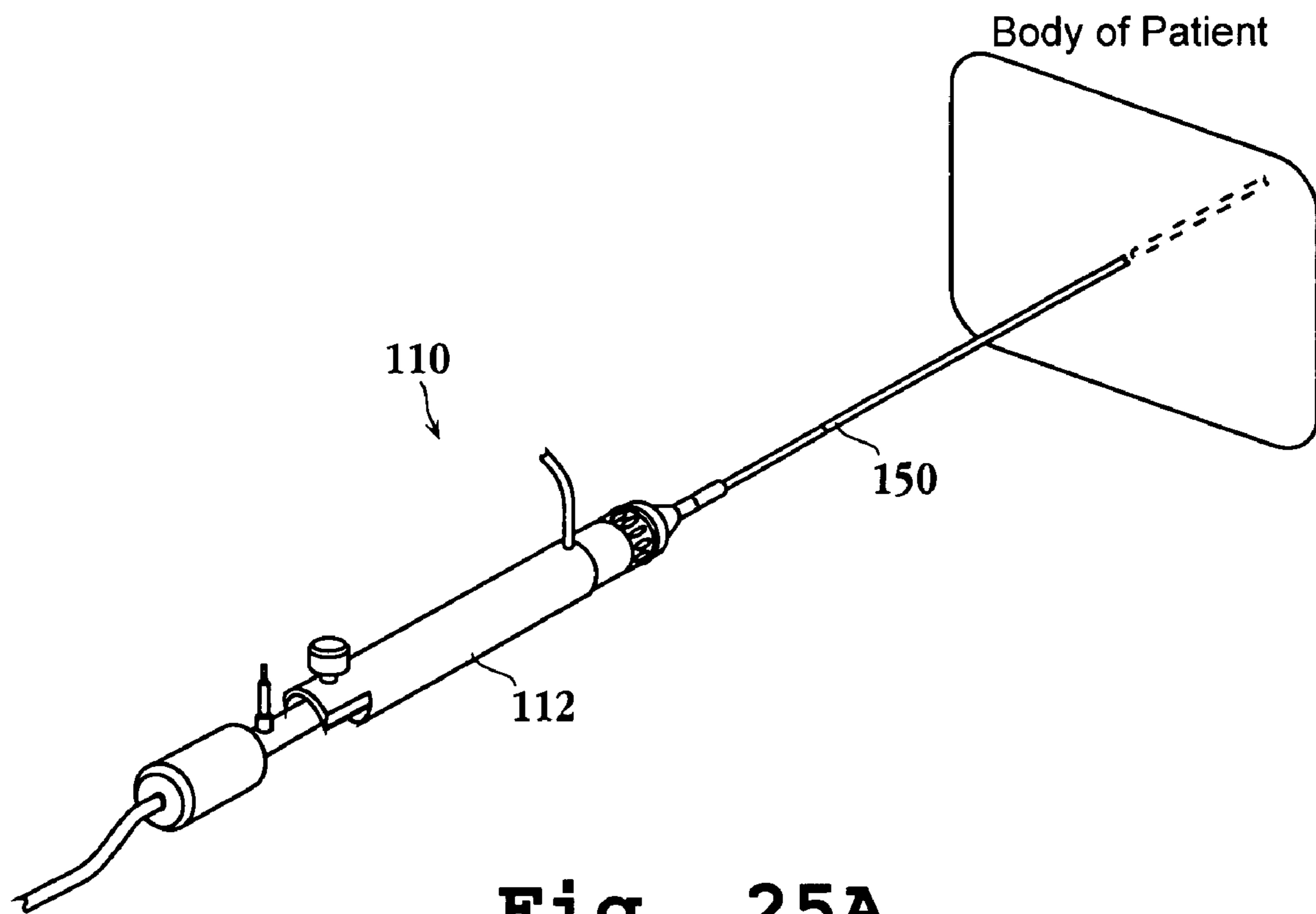


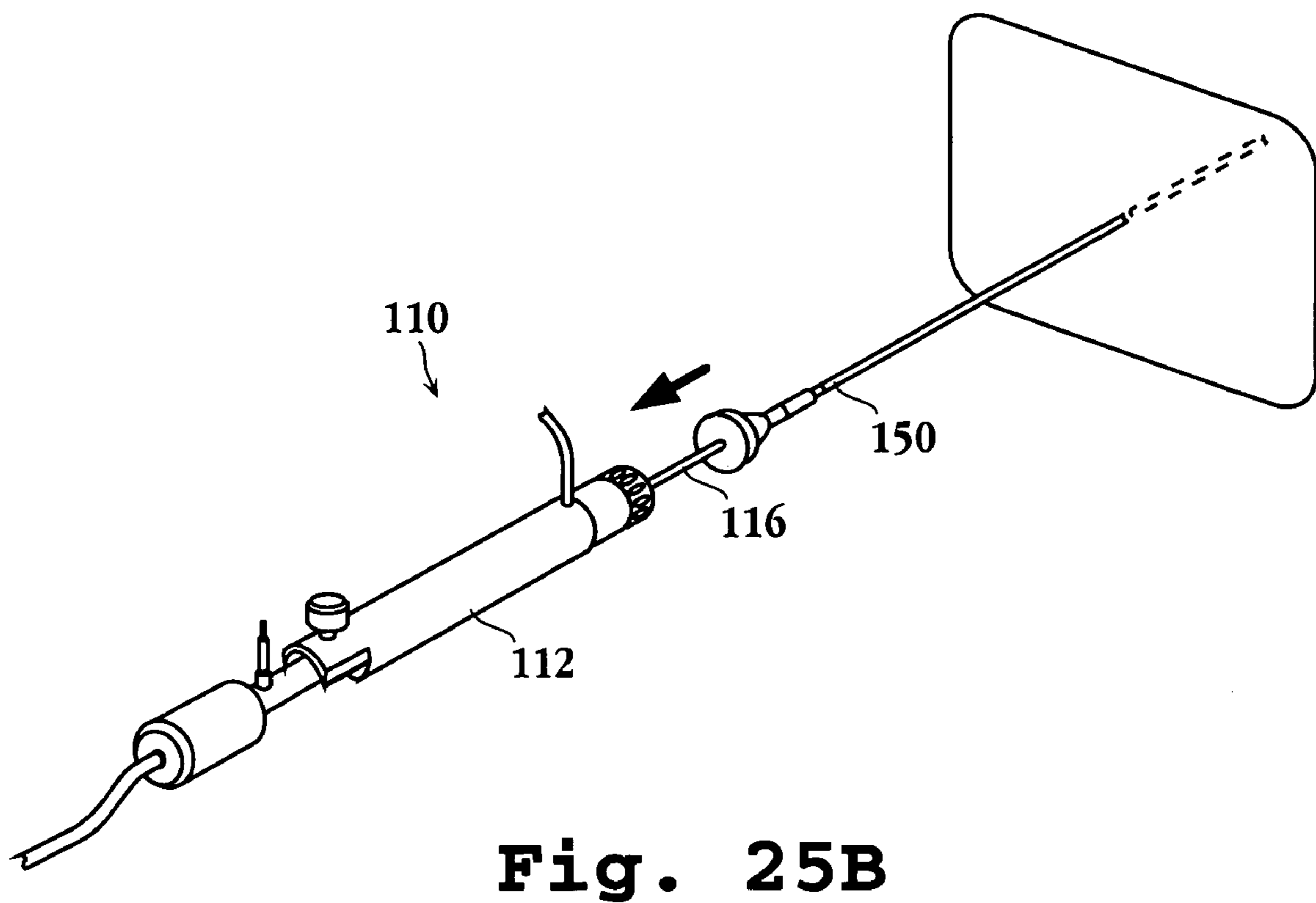
Fig. 23



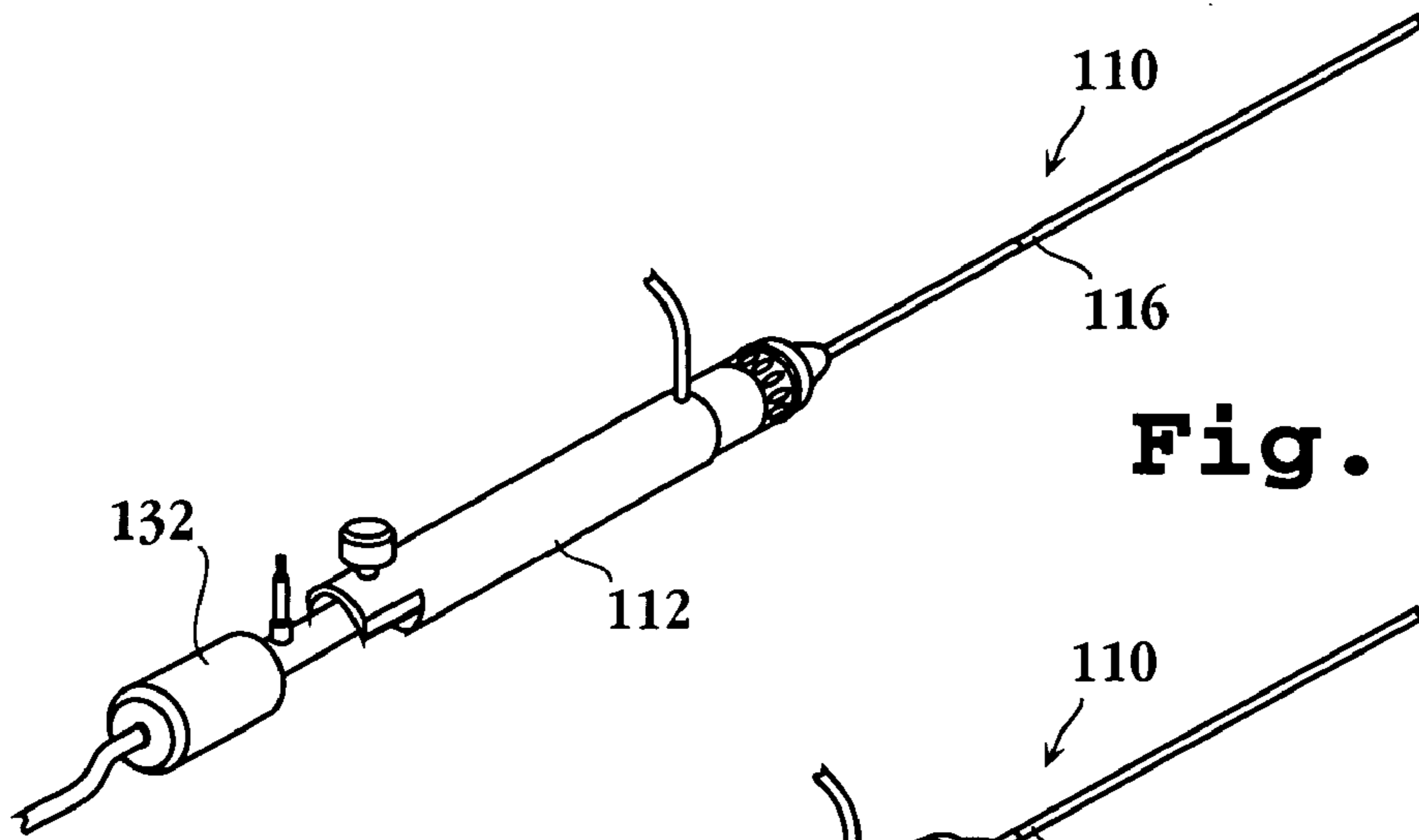
**Fig. 24**



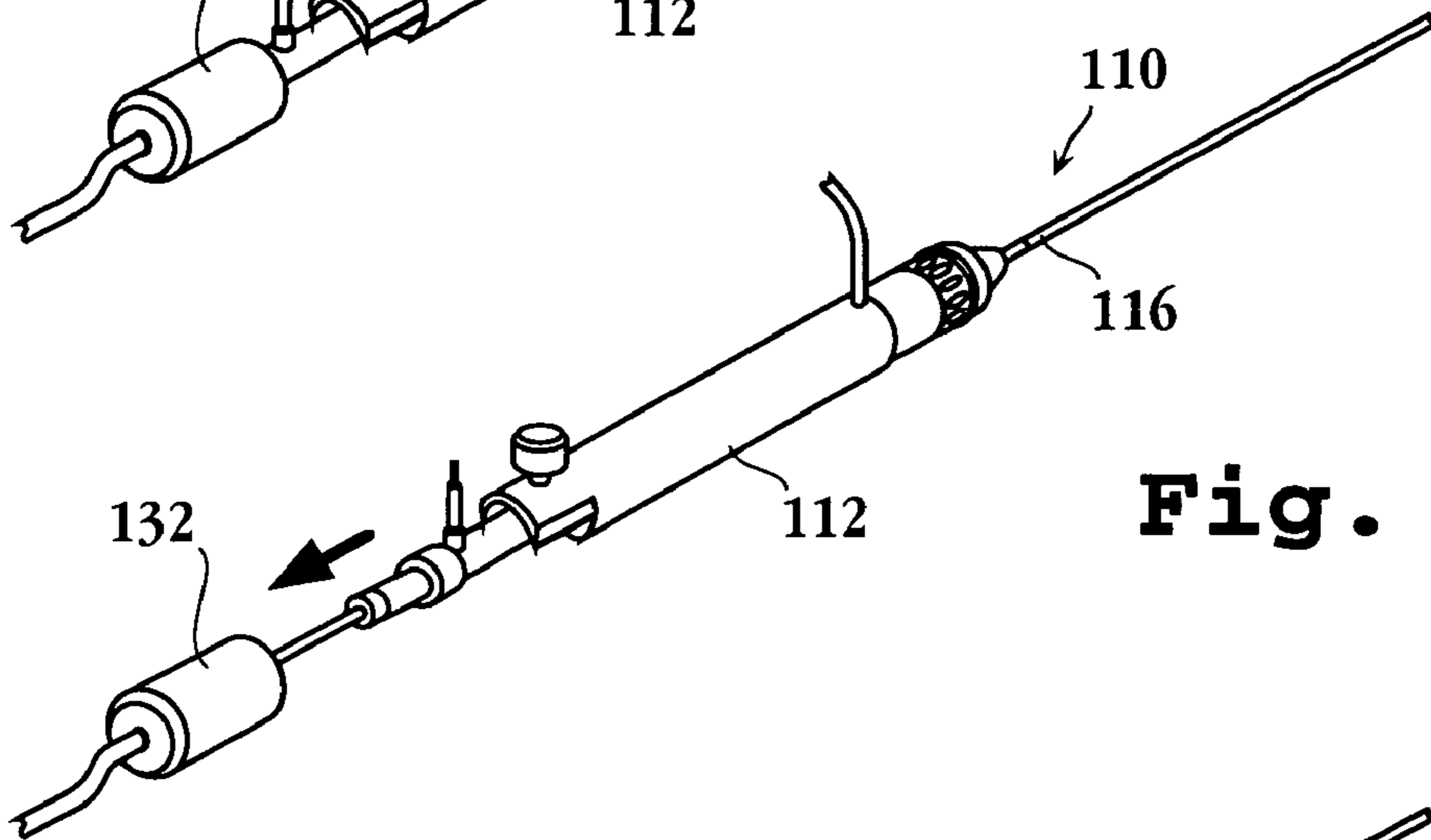
**Fig. 25A**



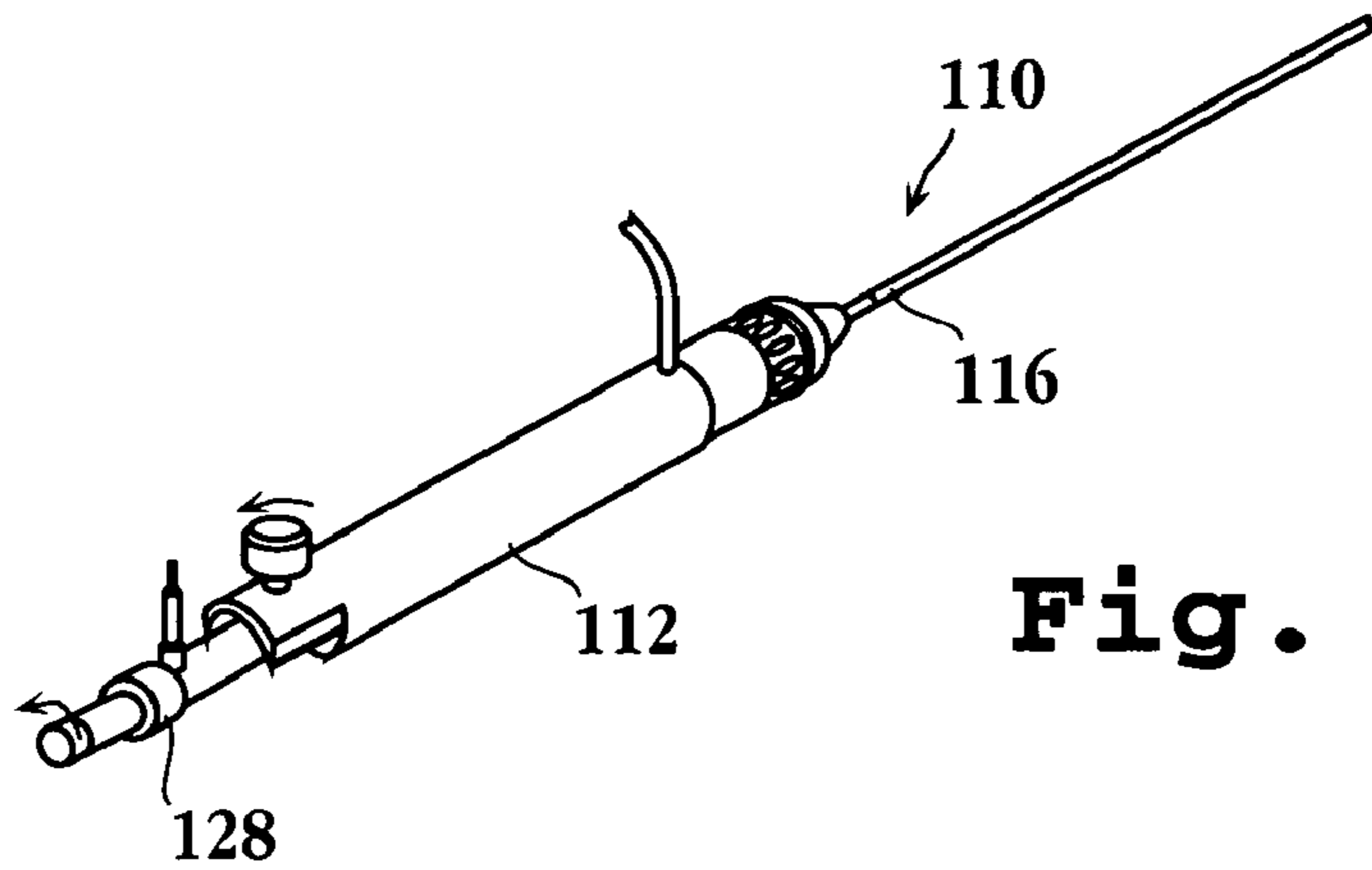
**Fig. 25B**



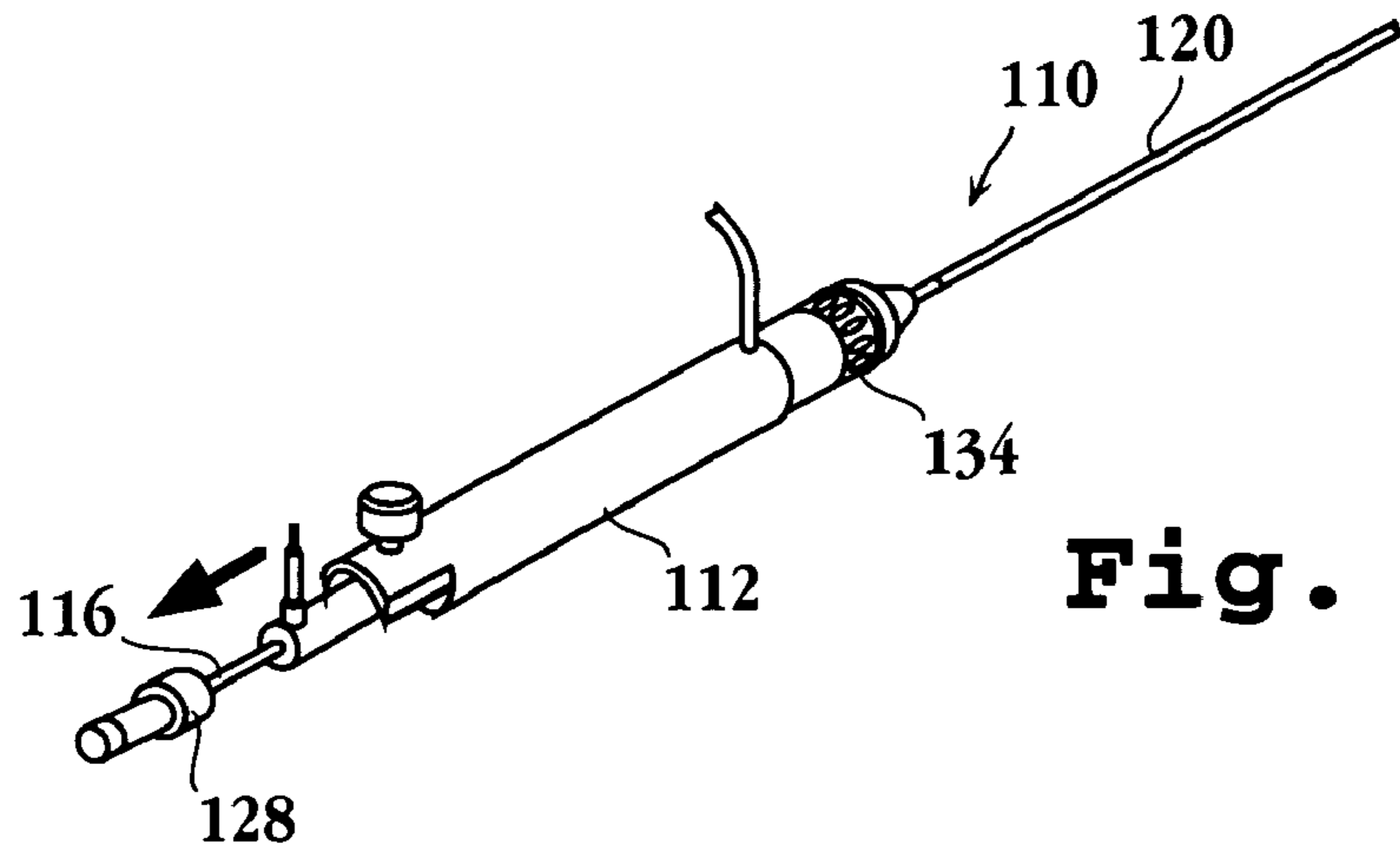
**Fig. 26A**



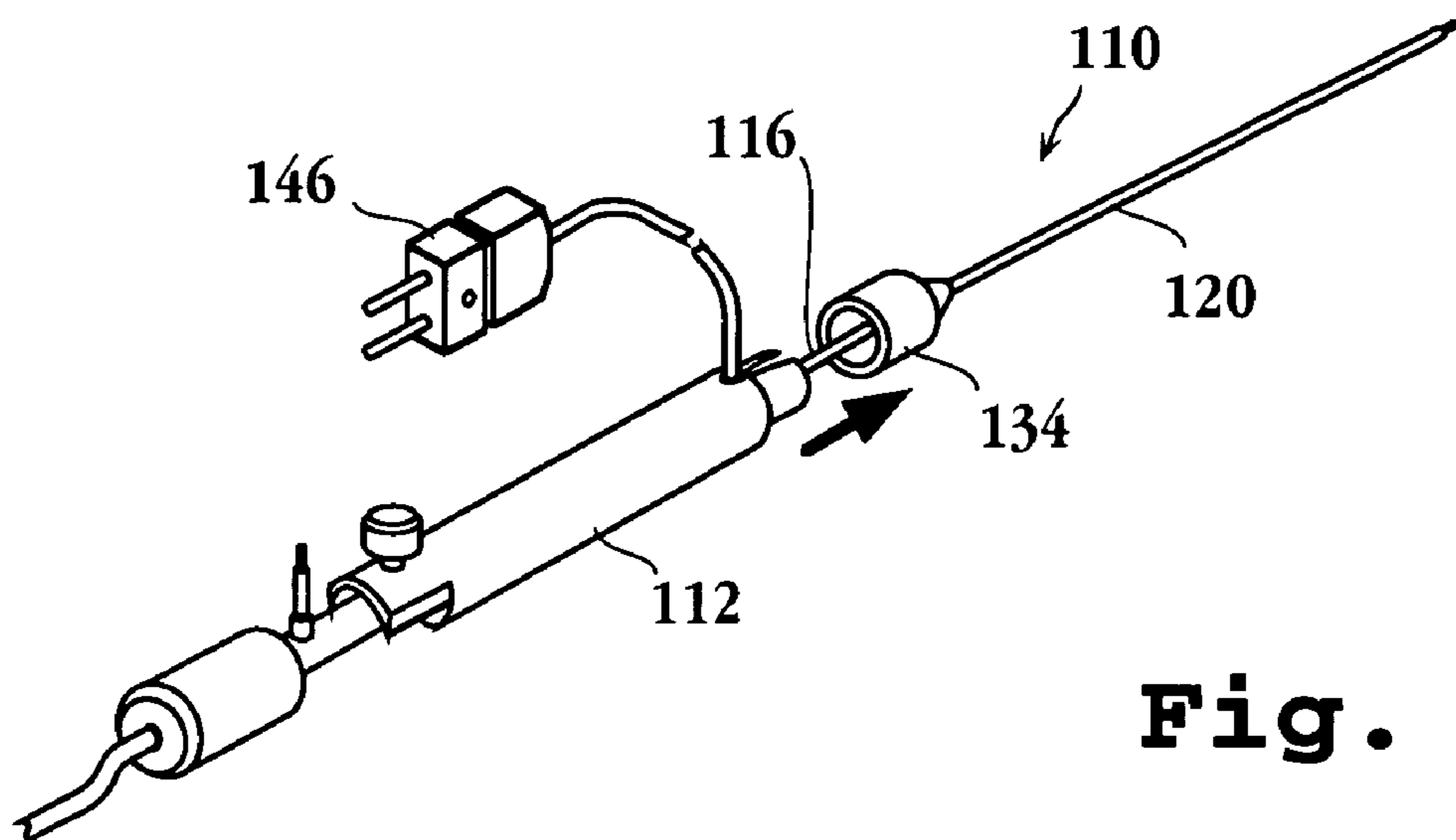
**Fig. 26B**



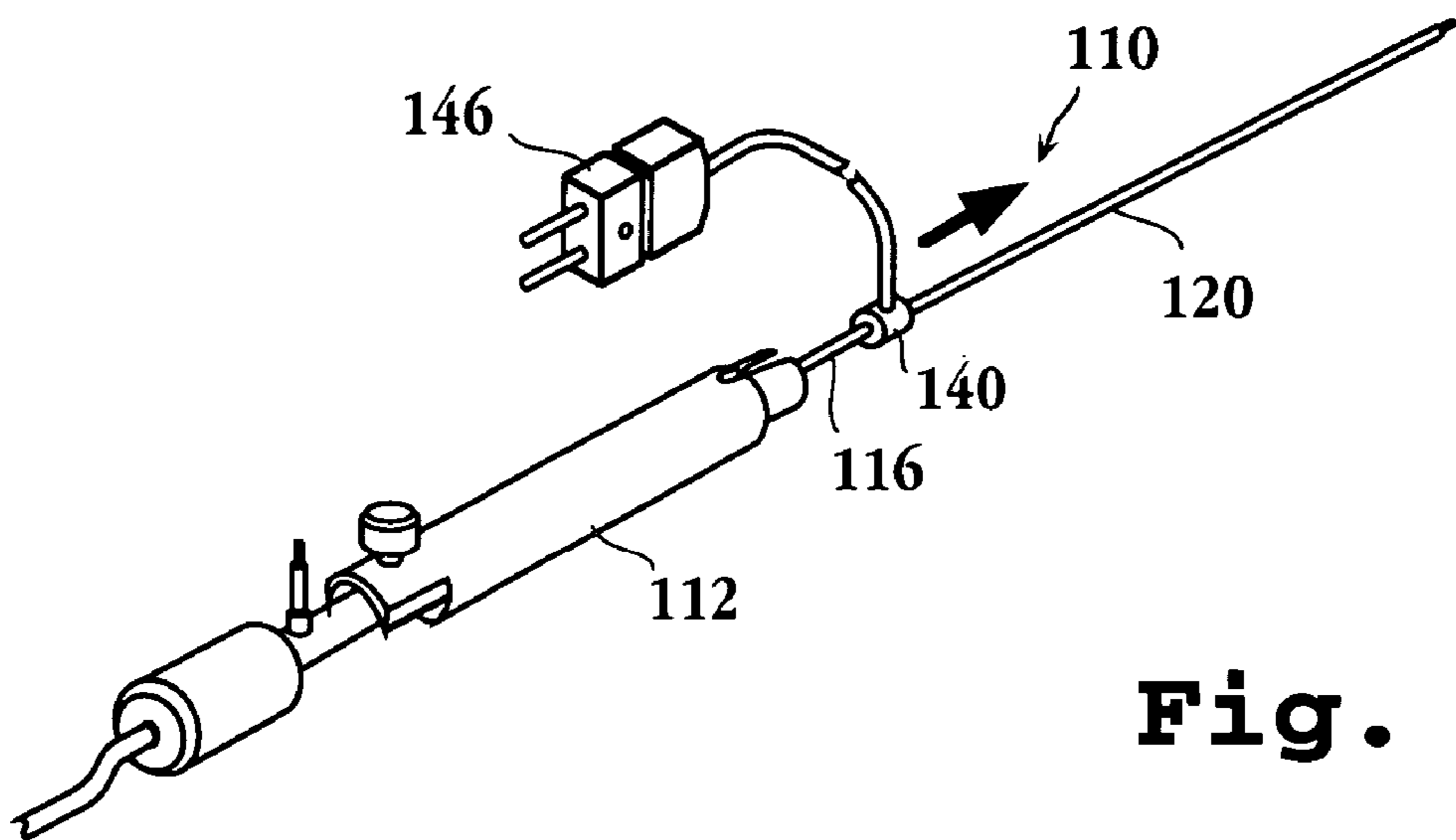
**Fig. 27A**



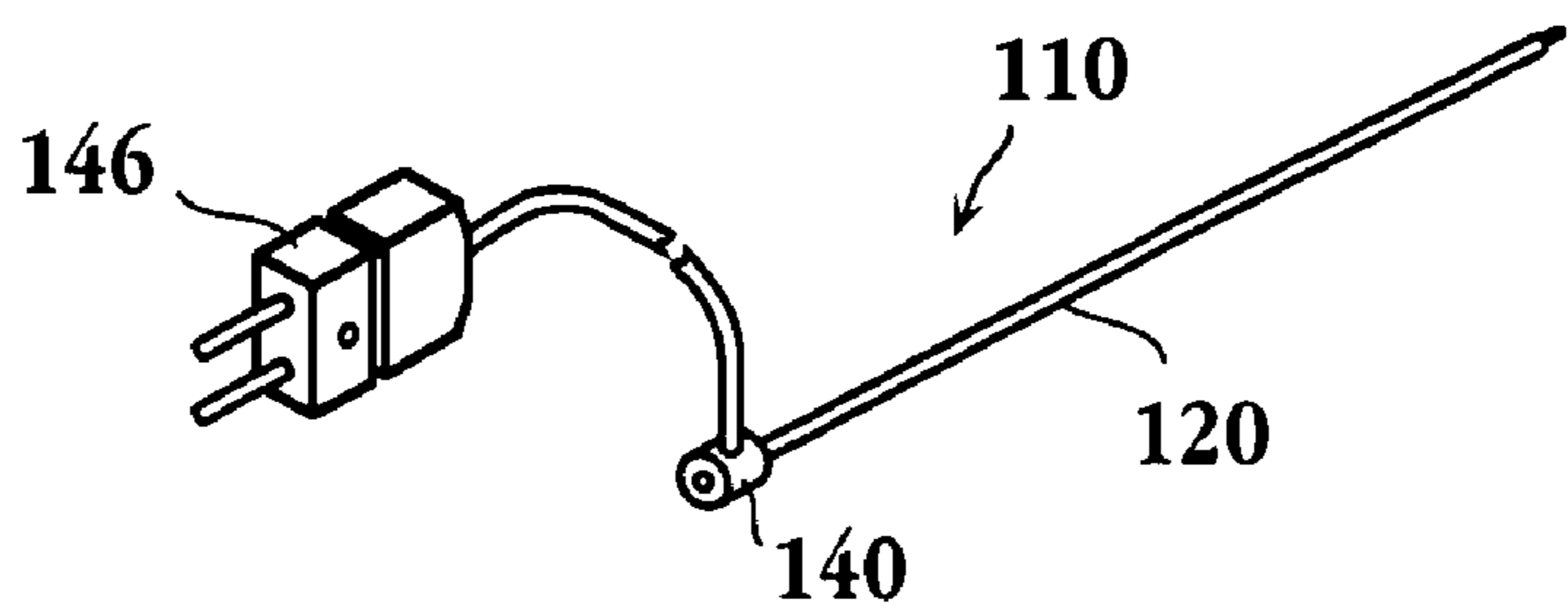
**Fig. 27B**



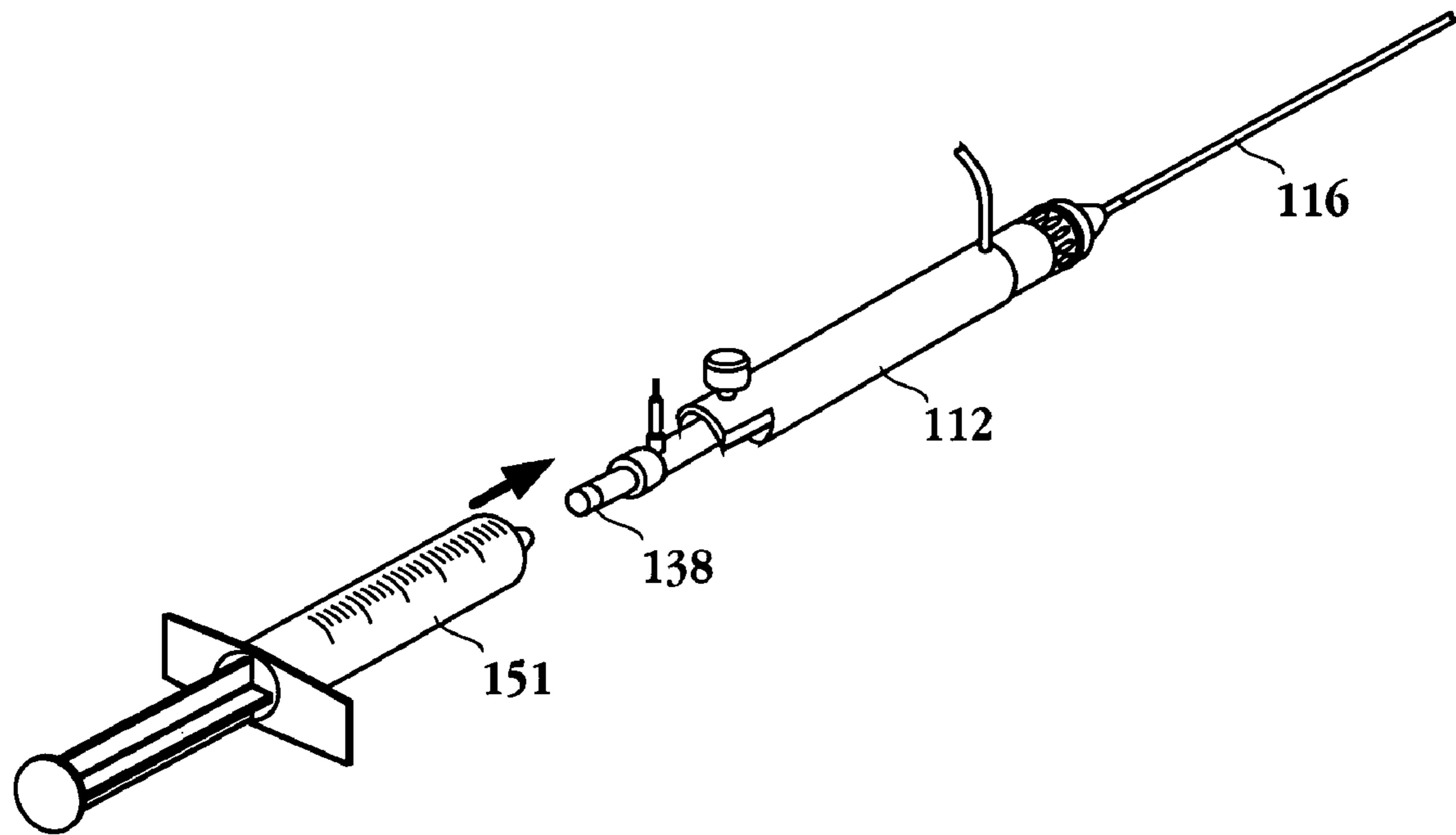
**Fig. 28A**



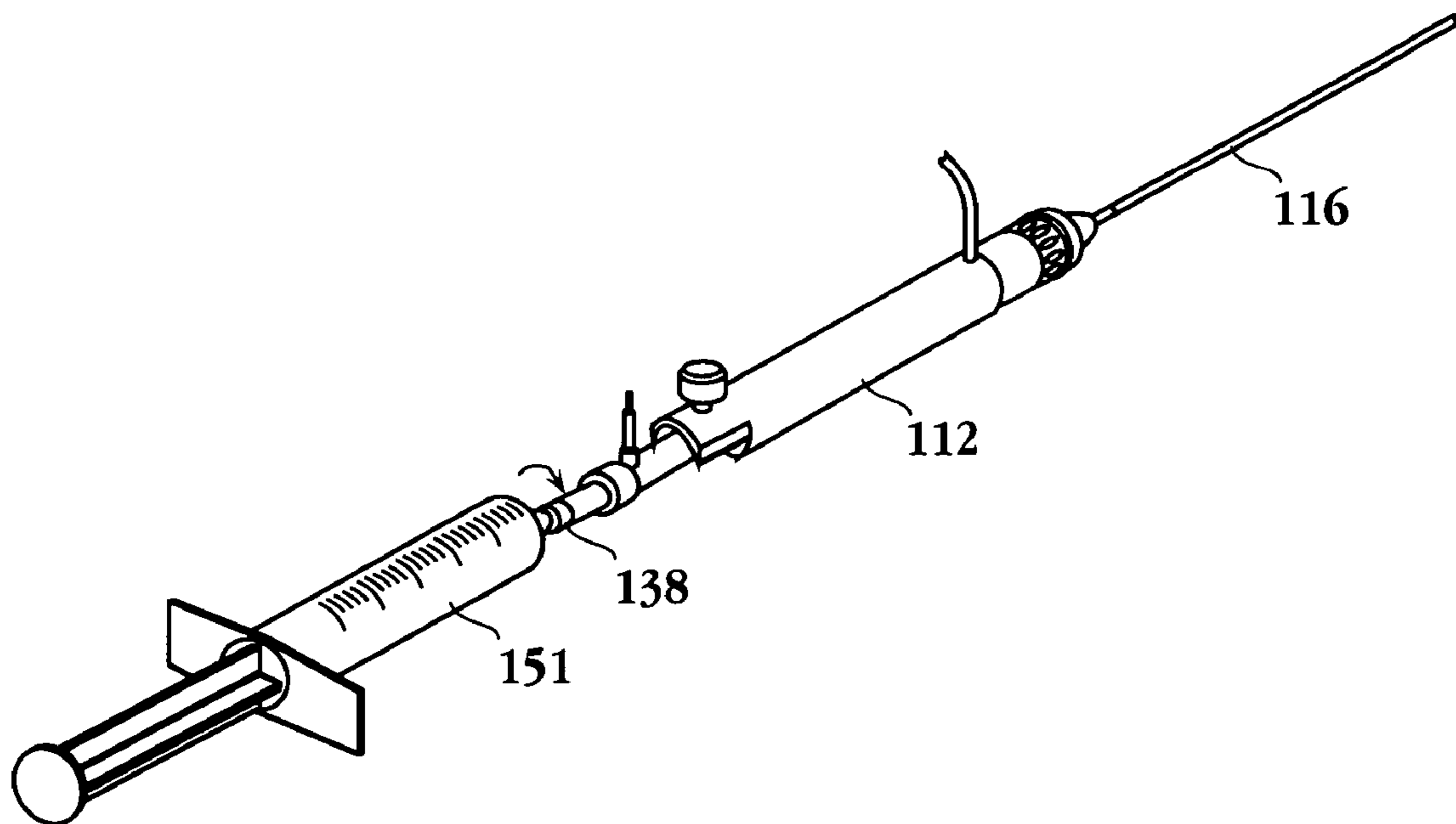
**Fig. 28B**



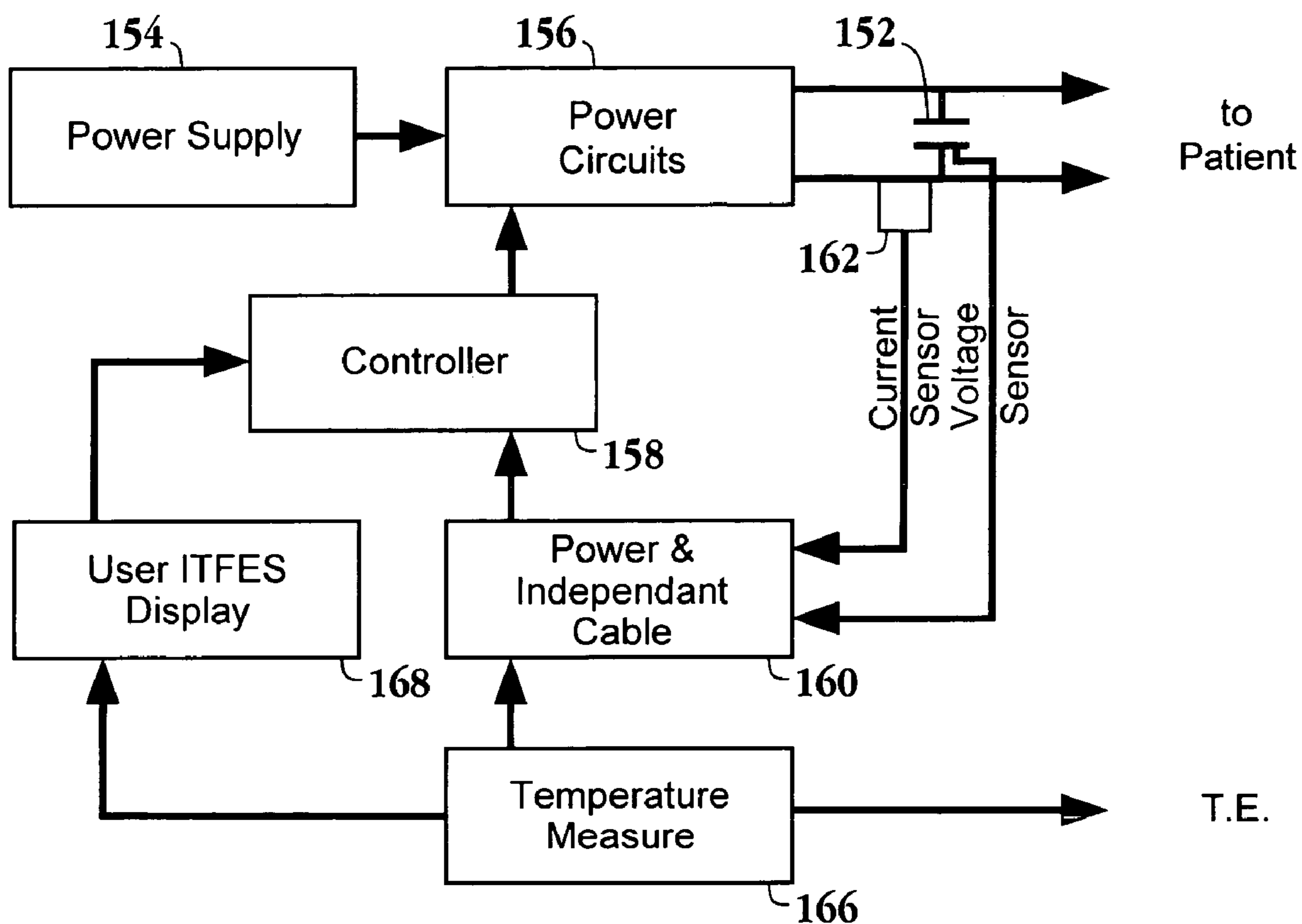
**Fig. 28C**



**Fig. 29A**



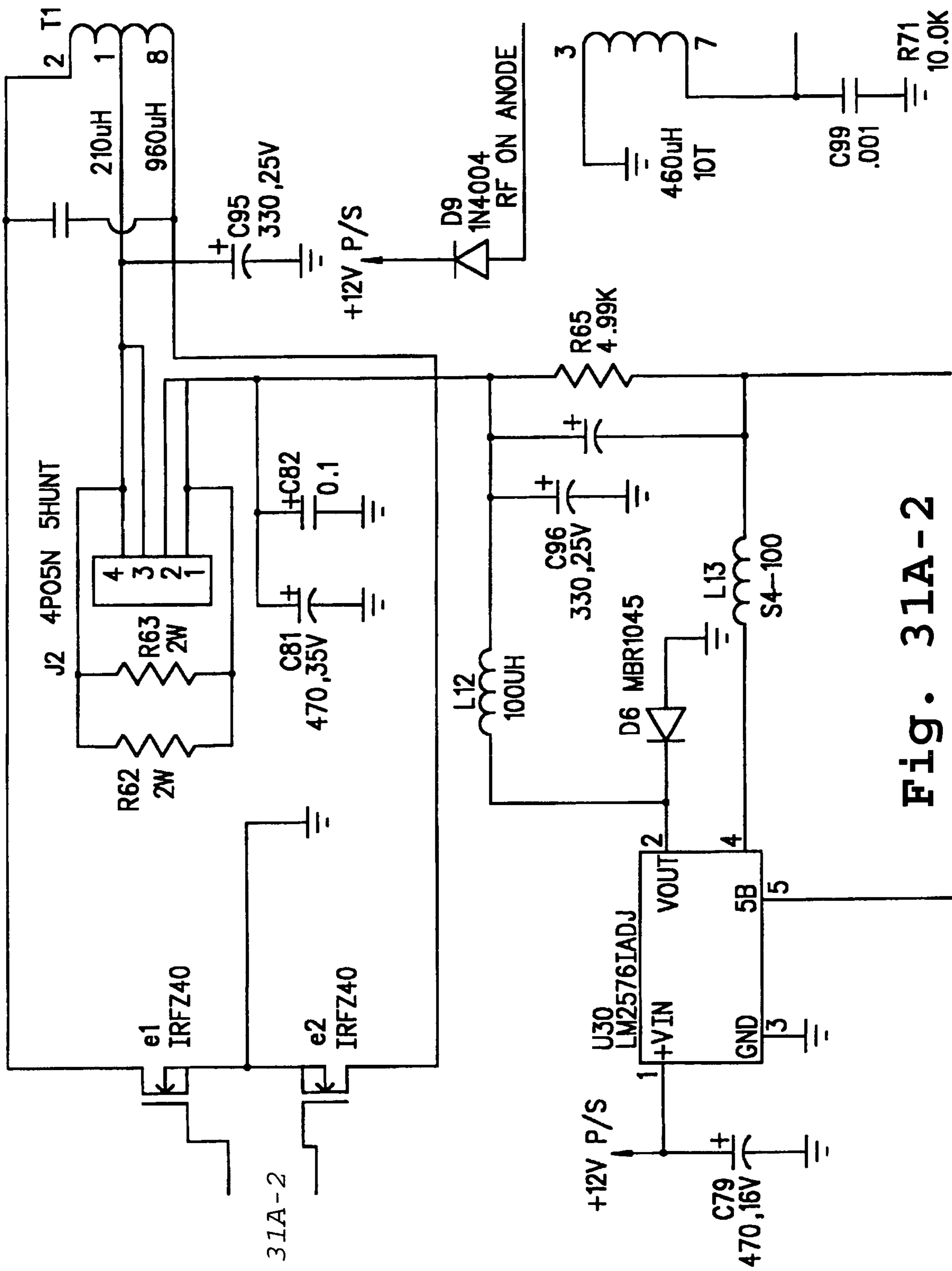
**Fig. 29B**



**Fig. 30**







to Fig. 31A-2

Fig. 31A-2

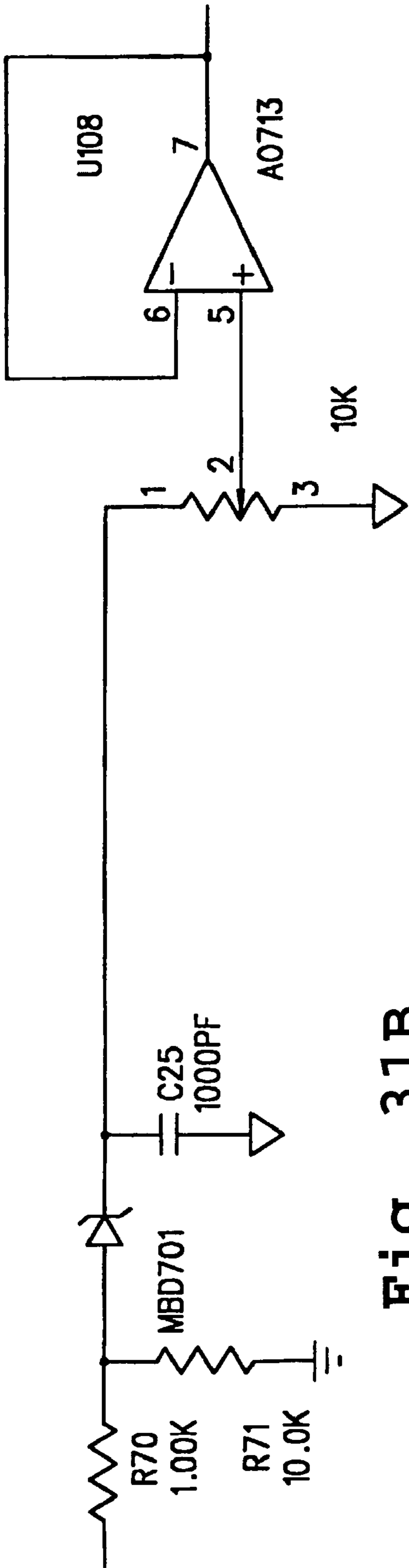


Fig. 31B

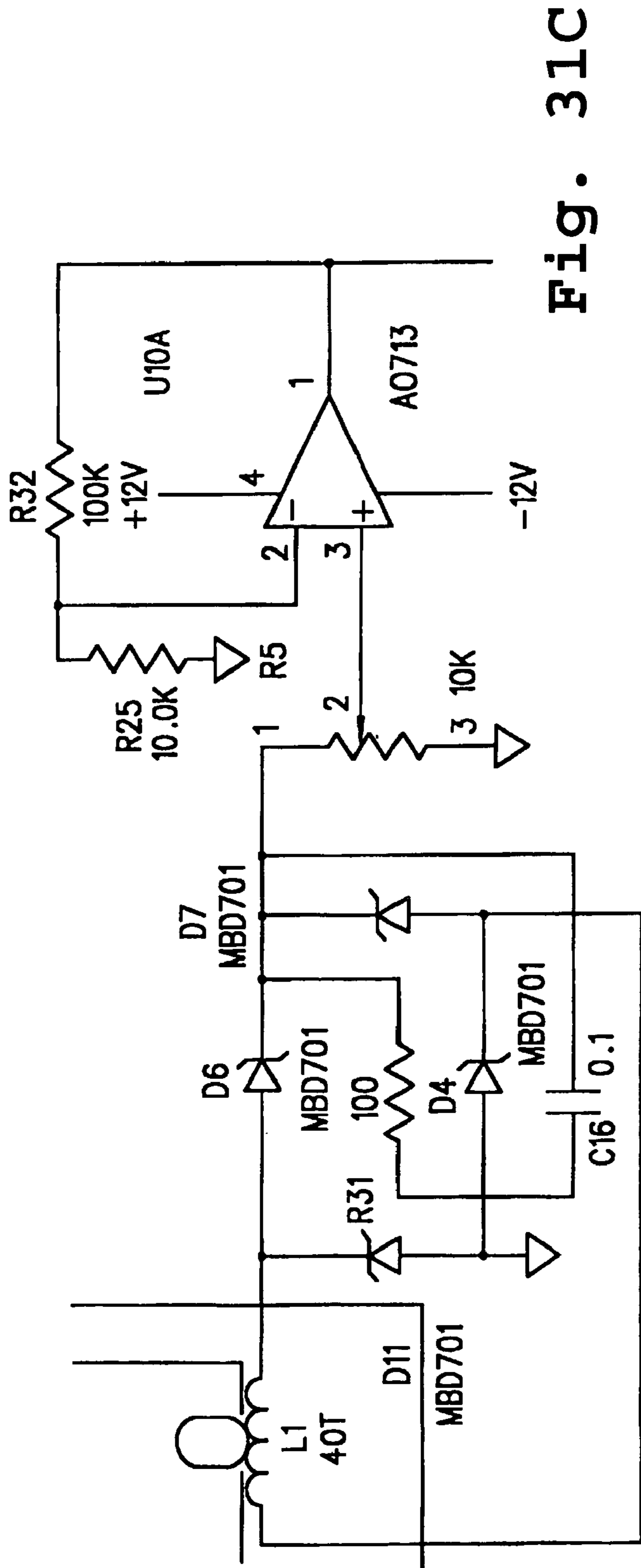


Fig. 31C

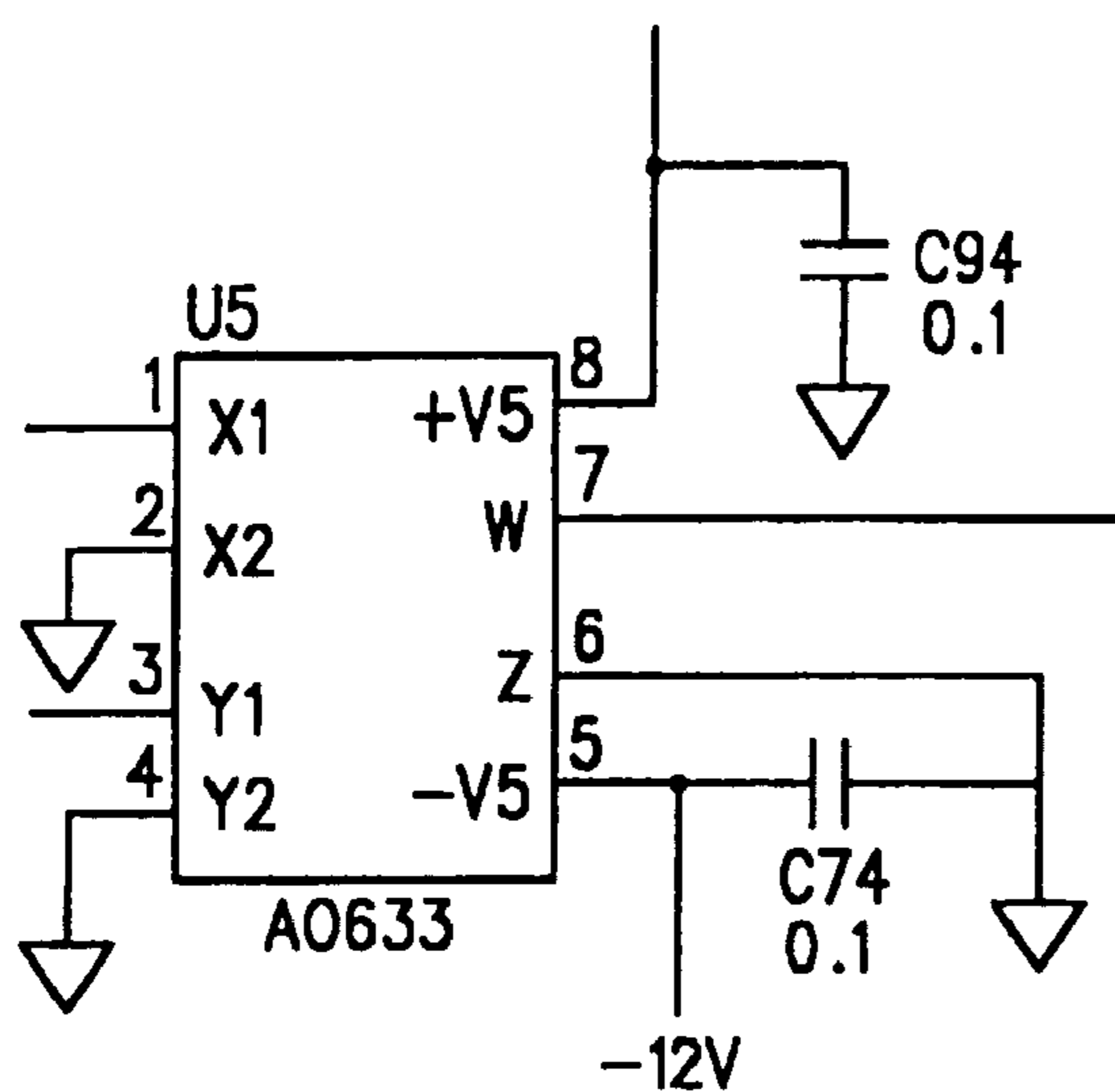


Fig. 31D

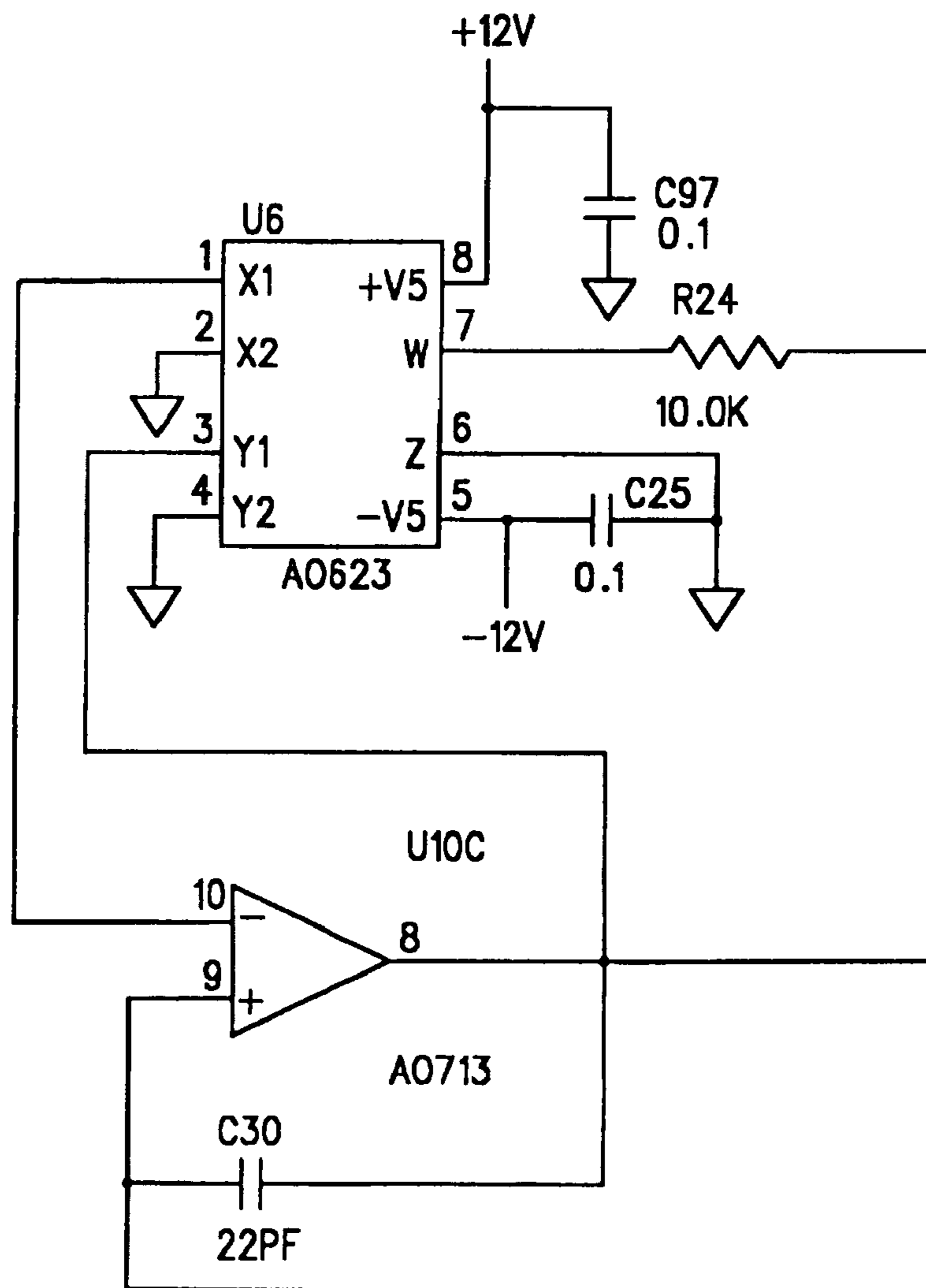
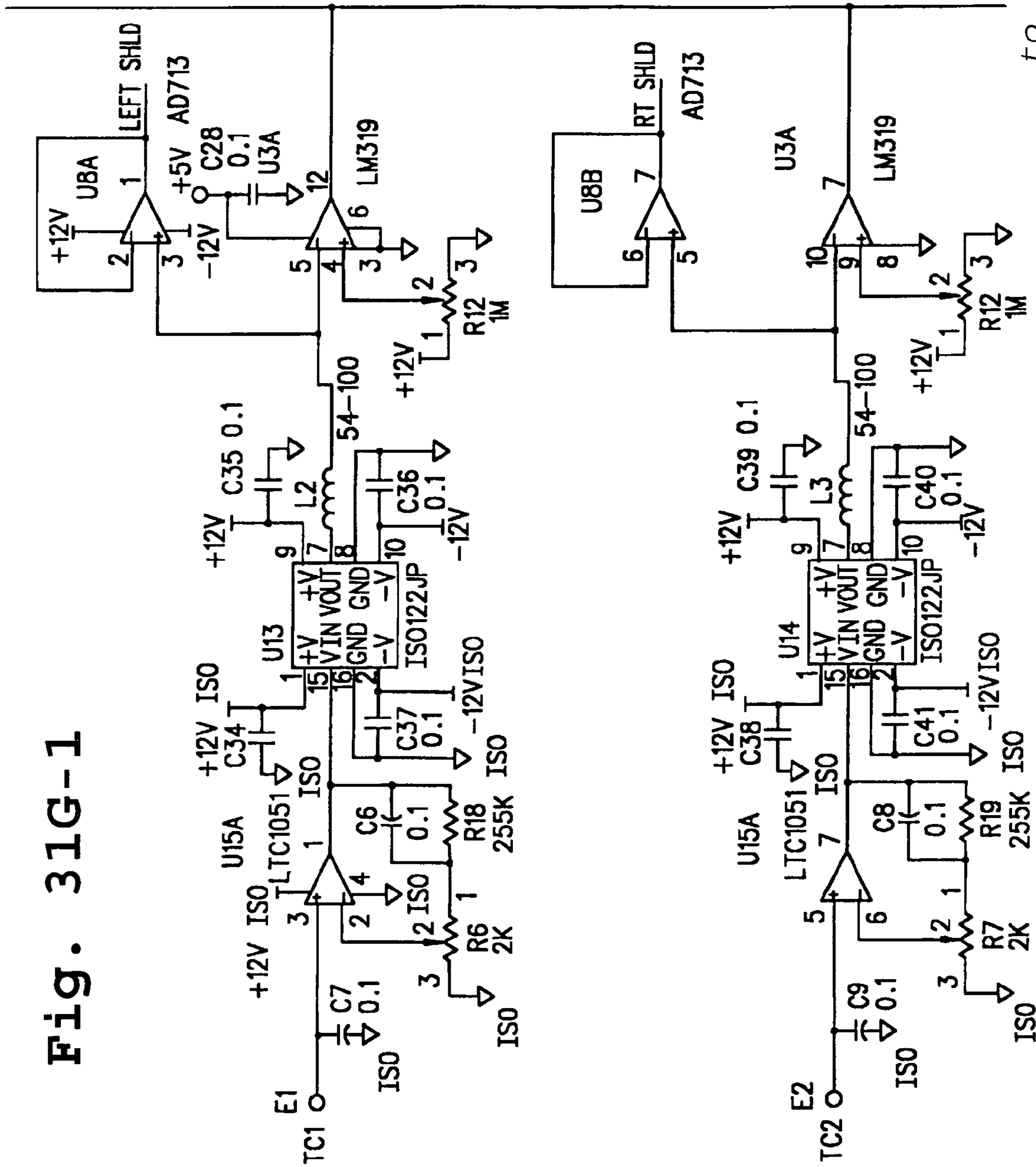


Fig. 31E



Fig. 31G-1



to Fig. 31G-3

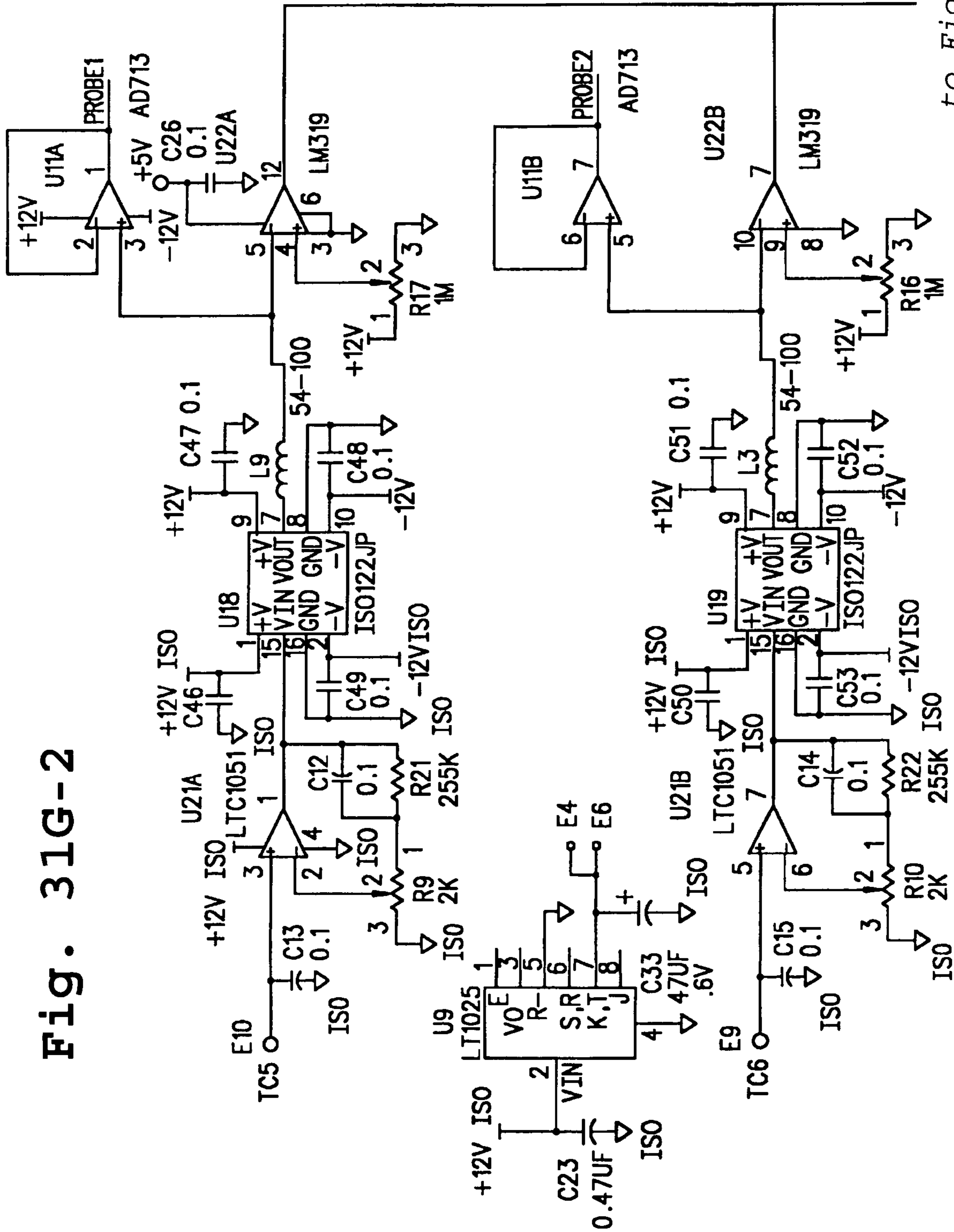


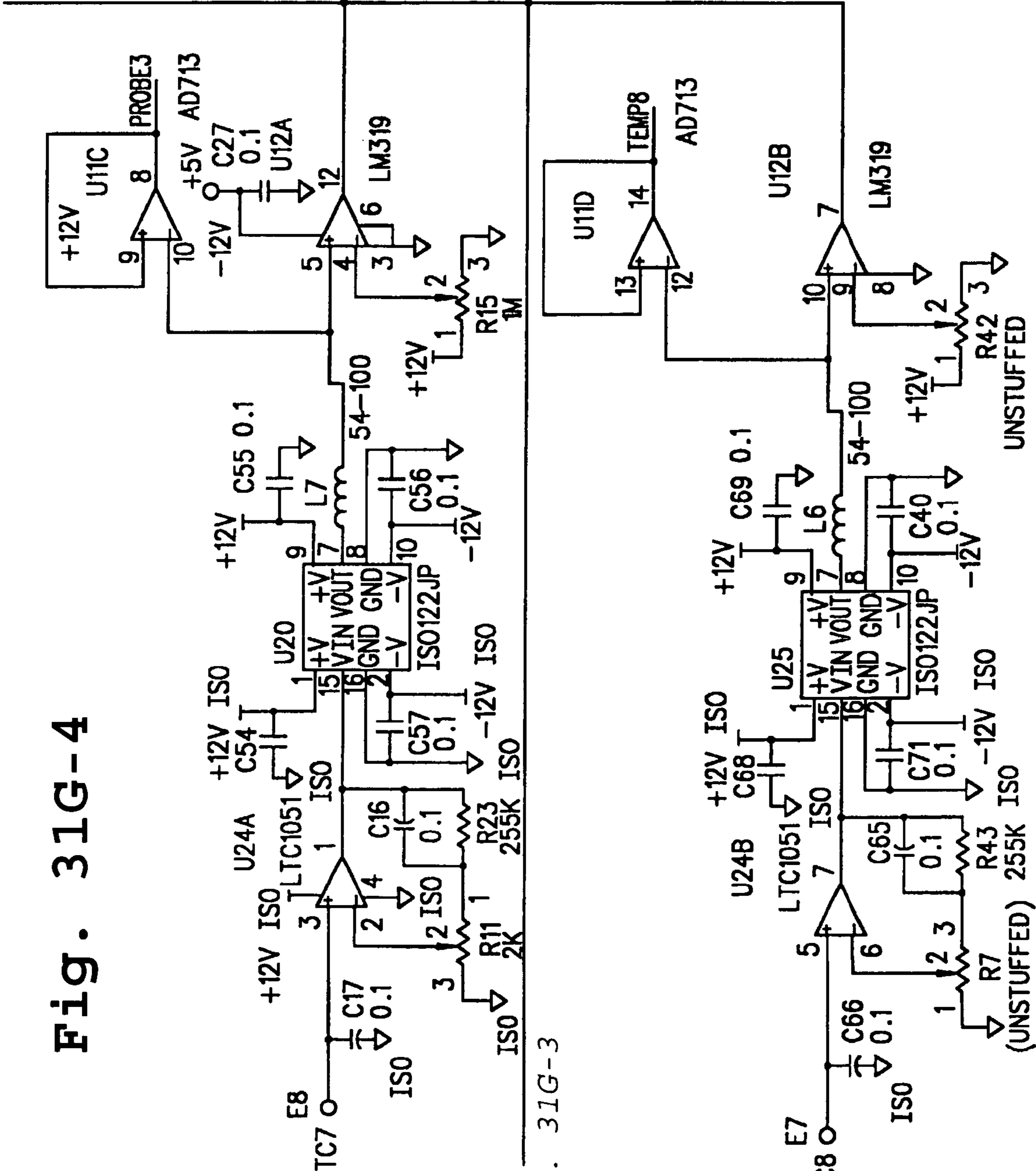
Fig. 31G-2

to Fig. 31G-4



to Fig. 31G-2

Fig. 31G-4



to Fig. 31G-3



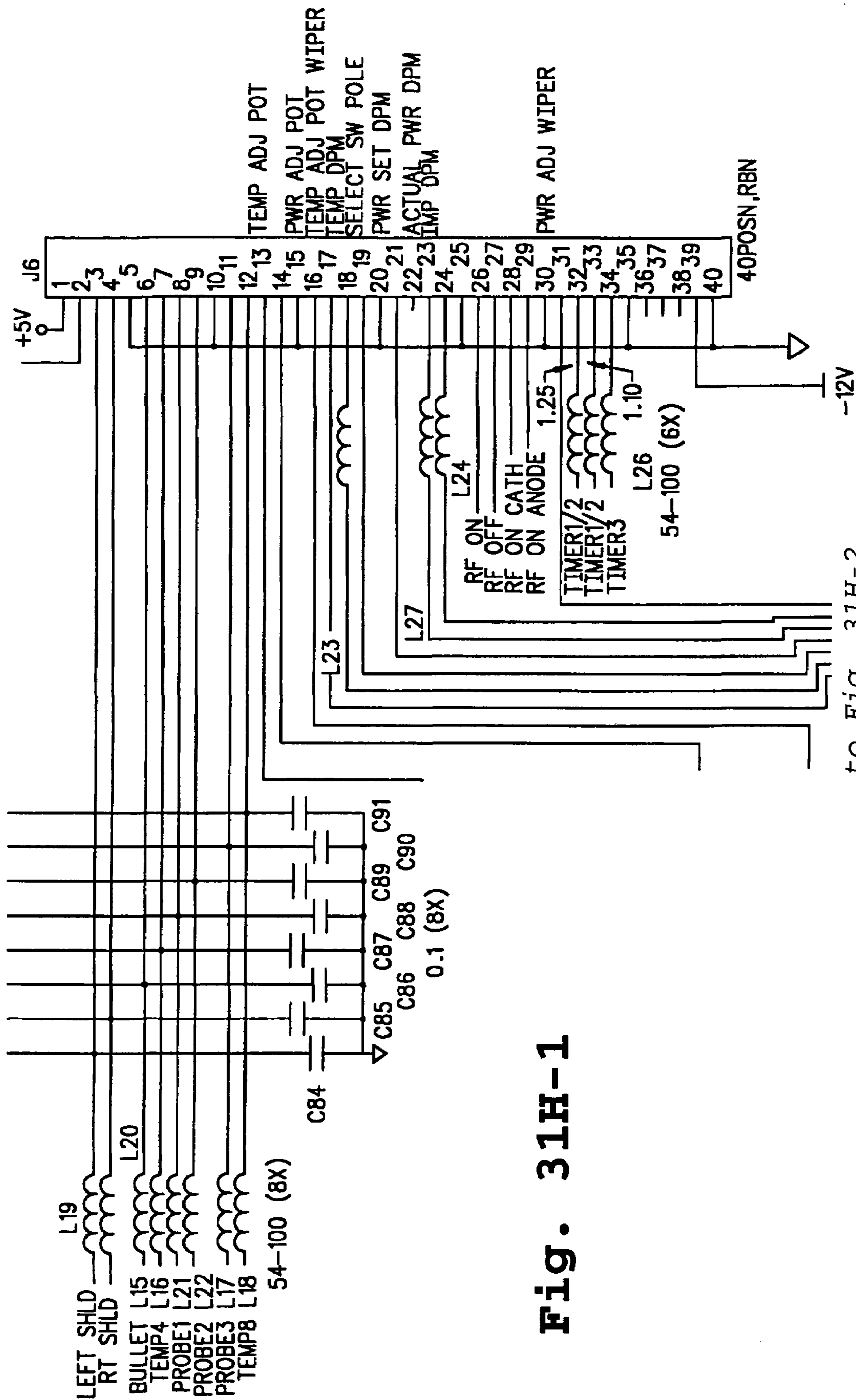
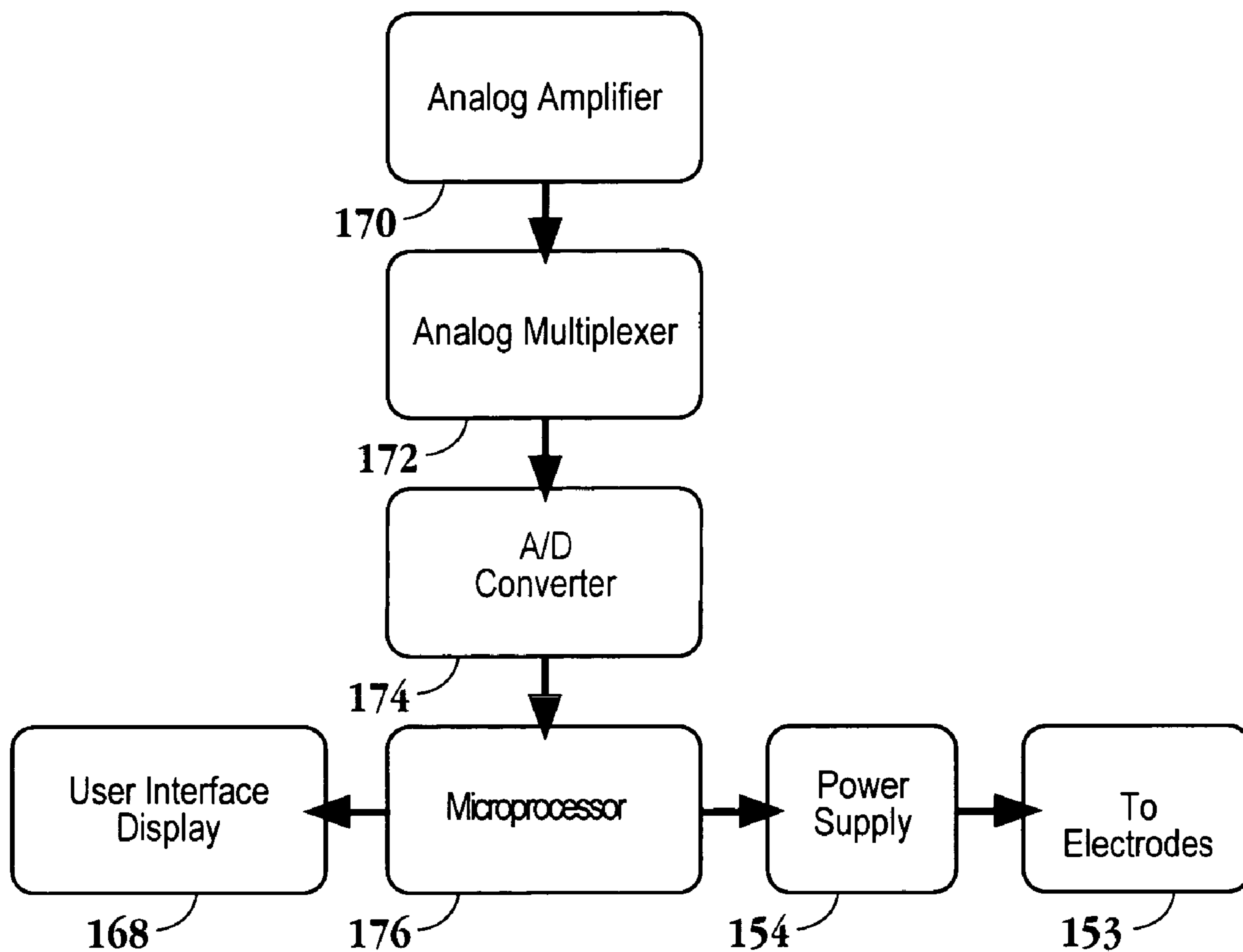


Fig. 31H-1

to Fig. 31H-2





**Fig. 32**

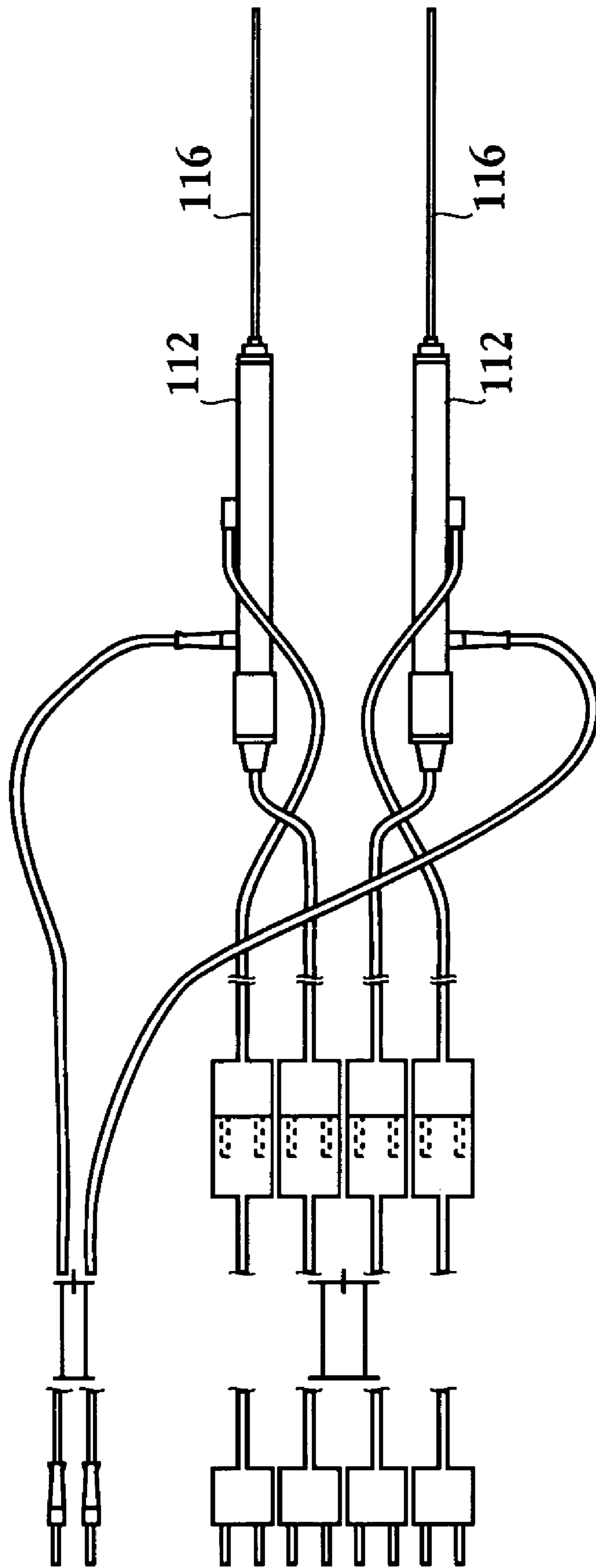


Fig. 33

**INFUSION ARRAY ABLATION APPARATUS**

This application is a continuation of U.S. patent application Ser. No. 09/513,725, filed Feb. 24, 2000, now U.S. Pat. No. 6,641,580, which is a continuation-in-part of U.S. patent application Ser. No. 09/383,166, filed Aug. 25, 1999, now U.S. Pat. No. 6,471,698, which is a continuation of U.S. patent application Ser. No. 08/802,195, filed Feb. 14, 1997, now U.S. Pat. No. 6,071,280, which is a continuation-in-part of U.S. patent application Ser. No. 08/515,379, filed Aug. 15, 1995, now U.S. Pat. No. 5,683,384, which is a continuation-in-part of U.S. patent application Ser. No. 08/290,031, filed Aug. 12, 1994, now U.S. Pat. No. 5,536,267, which is a continuation-in-part of U.S. patent application Ser. No. 08/148,439, filed Nov. 8, 1993, now U.S. Pat. No. 5,458,597, all of which are incorporated herein by reference.

The Ser. No. 09/513,725 application is also a continuation-in-part of U.S. patent application Ser. No. 09/364,203, filed Jul. 30, 1999, now U.S. Pat. No. 6,663,624, which is a continuation of U.S. patent application Ser. No. 08/623,652, filed Mar. 29, 1996, now U.S. Pat. No. 5,935,123, which is a divisional of U.S. patent application Ser. No. 08/295,166, filed Aug. 24, 1994, now U.S. Pat. No. 5,599,345, which is a continuation-in-part of U.S. patent application Ser. No. 08/148,439, filed Nov. 8, 1993, now U.S. Pat. No. 5,458,597, all of which are incorporated herein by reference.

**BACKGROUND OF THE INVENTION****1. Field of the Invention**

This invention relates generally to an apparatus for the treatment and ablation of body masses, such as tumors, and more particularly, to an RF treatment system suitable for multi-modality treatment with an infusion delivery and a retractable multiple needle electrode apparatus that surrounds an exterior of a tumor with a plurality of needle electrodes and defines an ablative volume. The system maintains a selected power at an electrode that is independent of changes in current or voltage.

**2. Description of Related Art**

Current open procedures for treatment of tumors are extremely disruptive and cause a great deal of damage to healthy tissue. During the surgical procedure, the physician must exercise care in not cutting the tumor in a manner that creates seeding of the tumor, resulting in metastasis. In recent years development of products has been directed with an emphasis on minimizing the traumatic nature of traditional surgical procedures.

There has been a relatively significant amount of activity in the area of hyperthermia as a tool for treatment of tumors. It is known that elevating the temperature of tumors is helpful in the treatment and management of cancerous tissues. The mechanisms of selective cancer cell eradication by hyperthermia are not completely understood. However, four cellular effects of hyperthermia on cancerous tissue have been proposed, (i) changes in cell or nuclear membrane permeability or fluidity, (ii) cytoplasmic lysosomal disintegration, causing release of digestive enzymes, (iii) protein thermal damage affecting cell respiration and the synthesis of DNA or RNA and (iv) potential excitation of immunologic systems. Treatment methods for applying heat to tumors include the use of direct contact radio-frequency (RF) applicators, microwave radiation, inductively coupled RF fields, ultrasound, and a variety of simple thermal conduction techniques.

Among the problems associated with all of these procedures is the requirement that highly localized heat be pro-

duced at depths of several centimeters beneath the surface of the body. Certain techniques have been developed with microwave radiation and ultrasound to focus energy at various desired depths. RF applications may be used at depth during surgery. However, the extent of localization is generally poor, with the result that healthy tissue may be harmed. Induction heating gives rise to poor localization of the incident energy as well. Although induction heating may be achieved by placing an antenna on the surface of the body, superficial eddy currents are generated in the immediate vicinity of the antenna. When it is driven using RF current unwanted surface heating occurs diminishing heating to the underlying tissue.

Thus, non-invasive procedures for providing heat to internal tumors have had difficulties in achieving substantial specific and selective treatment.

Hyperthermia, which can be produced from an RF or microwave source, applies heat to tissue but does not exceed 45 degrees C. so that normal cells survive. In thermotherapy, heat energy of greater than 45 degrees C. is applied, resulting in histological damage, desiccation and the denaturation of proteins. Hyperthermia has been applied more recently for therapy of malignant tumors. In hyperthermia, it is desirable to induce a state of hyperthermia that is localized by interstitial current heating to a specific area while concurrently insuring minimum thermal damage to healthy surrounding tissue. Often, the tumor is located subcutaneously and addressing the tumor requires either surgery, endoscopic procedures or external radiation. It is difficult to externally induce hyperthermia in deep body tissue because current density is diluted due to its absorption by healthy tissue. Additionally, a portion of the RF energy is reflected at the muscle/fat and bone interfaces which adds to the problem of depositing a known quantity of energy directly on a small tumor.

Attempts to use interstitial local hyperthermia have not proven to be very successful. Results have often produced nonuniform temperatures throughout the tumor. It is believed that tumor mass reduction by hyperthermia is related the thermal dose. Thermal dose is the minimum effective temperature applied throughout the tumor mass for a defined period of time. Because blood flow is the major mechanism of heat loss for tumors being heated, and blood flow varies throughout the tumor, more even heating of tumor tissue is needed to ensure more effective treatment.

The same is true for ablation of the tumor itself through the use of RF energy. Different methods have been utilized for the RF ablation of masses such as tumors. Instead of heating the tumor it is ablated through the application of energy. This process has been difficult to achieve due to a variety of factors including, (i) positioning of the RF ablation electrodes to effectively ablate all of the mass, (ii) introduction of the RF ablation electrodes to the tumor site and (iii) controlled delivery and monitoring of RF energy to achieve successful ablation without damage to non-tumor tissue.

There have been a number of different treatment methods and devices for minimally invasively treating tumors. One such example is an endoscope that produces RF hyperthermia in tumors, as disclosed in U.S. Pat. No. 4,920,978. A microwave endoscope device is described in U.S. Pat. No. 4,409,993. In U.S. Pat. No. 4,920,978, an endoscope for RF hyperthermia is disclosed.

In U.S. Pat. No. 4,763,671, a minimally invasive procedure utilizes two catheters that are inserted interstitially into the tumor. The catheters are placed within the tumor volume and each is connect to a high frequency power source.

In U.S. Pat. No. 4,565,200, an electrode system is described in which a single entrance tract cannula is used to introduce an electrode into a selected body site.

However, as an effective treatment device, electrodes must be properly positioned relative to the tumor. After the electrodes are positioned, it is then desirable to have controlled application and deposition of RF energy to ablate the tumor. This reduces destruction of healthy tissue.

There is a need for a RF tumor treatment apparatus that is useful for minimally invasive procedures. It would be desirable for such a device to surround the exterior of the tumor with treatment electrodes, defining a controlled ablation volume, and subsequently the electrodes deliver a controlled amount of RF energy. Additionally, there is a need for a device with infusion capabilities during a pre-ablation step, and after ablation the surrounding tissue can be preconditioned with electromagnetic ("EM") energy at hyperthermia temperatures less than 45 degrees. This would provide for the synergistic affects of chemotherapy and the instillation of a variety of fluids at the tumor site after local ablation and hyperthermia.

#### SUMMARY OF THE INVENTION

In an embodiment of the invention, an infusion array ablation apparatus includes an elongated delivery device having a lumen and an infusion array positionable in the lumen. The infusion array includes an RF electrode and at least a first and a second infusion member. Each infusion member has a tissue piercing distal portion and an infusion lumen. At least one of the first or second infusion members is positionable in the elongated delivery device in a compacted state and deployable from the elongated delivery device with curvature in a deployed state. Also, at least one of the first or second infusion members exhibits a changing direction of travel when advanced from the elongated delivery device to a selected tissue site. At least one infusion port is coupled to one of the elongated delivery device, the infusion array, the first infusion member or the second infusion member.

In another embodiment, a tissue ablation apparatus includes a delivery catheter, with distal and proximal ends. A handle is attached to the proximal end of the delivery catheter. An electrode deployment apparatus is positioned at least partially in the delivery catheter. It includes a plurality of electrodes that are retractable in and out of the catheter's distal end. The electrodes are in a non-deployed state when they are positioned within the delivery catheter. As they are advanced out the distal end of the catheter they become deployed, and define an ablation volume. Each electrode has a first section with a first radius of curvature, and a second section, extending beyond the first section, having a second radius of curvature or a substantially linear geometry. Alternatively, each deployed electrode has at least two radii of curvature that are formed when the needle is advanced through the delivery catheter's distal end and becomes positioned at a selected tissue site. Also each deployed electrode can have at least one radius of curvature in two or more planes. Further, the electrode deployment apparatus can include at least one deployed electrode having at least one radius of curvature, and at least one deployed electrode with at least one radius of curvature in two or more planes.

In a further embodiment, the electrode deployment apparatus has at least one deployed electrode with at least one curved section that is located near the distal end of the delivery catheter, and a non-curved section which extends beyond the curved section of the deployed electrode. The

electrode deployment apparatus also has at least one deployed electrode with at least two radii of curvature.

In another embodiment of the invention, each deployed electrode has at least one curved section located near the distal end of the delivery catheter, and a non-curved section that extends beyond the curved section of the deployed electrode.

An electrode template can be positioned at the distal end of the delivery catheter. It assists in guiding the deployment of the electrodes to a surrounding relationship at an exterior of a selected mass in a tissue. The electrodes can be hollow. An adjustable electrode insulator can be positioned in an adjacent, surrounding relationship to all or some of the electrodes. The electrode insulator is adjustable, and capable of being advanced and retracted along the electrodes in order to define an electrode conductive surface.

The electrode deployment apparatus can include a cam which advances and retracts the electrodes in and out of the delivery catheter's distal end. Optionally included in the delivery catheter are one or more guide tubes associated with one or more electrodes. The guide tubes are positioned at the delivery catheter's distal end.

Sources of infusing mediums, including but not limited to electrolytic and chemotherapeutic solutions, can be associated with the hollow electrodes. Electrodes can have sharpened, tapered ends in order to assist their introduction through tissue, and advancement to the selected tissue site.

The electrode deployment apparatus is removable from the delivery catheter. An obturator is initially positioned within the delivery catheter. It can have a sharpened distal end. The delivery catheter can be advanced percutaneously to an internal body organ, or site, with the obturator positioned in the delivery catheter. Once positioned, the obturator is removed, and the electrode deployment apparatus is inserted into the delivery catheter. The electrodes are in non-deployed states, and preferably compacted or spring-loaded, while positioned within the delivery catheter. They are made of a material with sufficient strength so that as the electrodes emerge from the delivery catheter's distal end they are deployed three dimensionally, in a lateral direction away from the periphery of the delivery catheter's distal end. The electrodes continue their lateral movement until the force applied by the tissue causes the needles to change their direction of travel.

Each electrode now has either, (i) a first section with a first radius of curvature, and a second section, extending beyond the first section, having a second radius of curvature or a substantially linear section, (ii) two radii of curvature, (iii) one radius of curvature in two or more planes, or (iv) a combination of two radii of curvature with one of them in two or more planes. Additionally, the electrode deployment apparatus can include one or more of these deployed geometries for the different electrodes in the plurality. It is not necessary that every electrode have the same deployed geometry.

After the electrodes are positioned around a mass, such as a tumor, a variety of solutions, including but not limited to electrolytic fluids, can be introduced through the electrodes to the mass in a pre-ablation step. RF energy is applied, and the mass is desiccated. In a post-ablation procedure, a chemotherapeutic agent can then be introduced to the site, and the electrodes are then retracted back into the introducing catheter. The entire ablative apparatus can be removed, or additional ablative treatments be conducted.

## BRIEF DESCRIPTION OF THE FIGURES

FIG. 1 is a perspective view of the tissue ablation apparatus of the invention, including a delivery catheter, handle, and deployed electrodes.

FIG. 2 is a cross-sectional view of the tissue ablation apparatus of the invention illustrated in FIG. 1.

FIG. 3 is a perspective view of an electrode of the invention with two radii of curvature.

FIG. 4 is a perspective view of an electrode of the invention with one radius of curvature in three planes.

FIG. 5 is a perspective view of an electrode of the invention with one curved section, positioned close to the distal end of the delivery catheter, and a linear section.

FIG. 6 is a perspective view of an electrode of the invention with one curved section, positioned close to the distal end of the delivery catheter, a generally first linear section, and then a second linear section that continues laterally with regard to the first linear section.

FIG. 7 is a cross-section view of a delivery catheter associated with the invention, with guide tubes positioned at the distal end of the delivery catheter.

FIG. 8 is a cross-sectional view of an electrode of the invention.

FIG. 9 is a perspective view of the tissue ablation apparatus of the invention shown in FIG. 1, with the delivery catheter being introduced percutaneously through the body and positioned at the exterior, or slightly piercing, a liver with a tumor to be ablated.

FIG. 10 is a perspective view of the tissue ablation apparatus of the invention with an obturator positioned in the delivery catheter.

FIG. 11 is a perspective view of the tissue ablation apparatus of the invention shown in FIG. 10, positioned in the body adjacent to the liver, with the obturator removed.

FIG. 12 is a perspective view of the tissue ablation apparatus of the invention shown in FIG. 10, positioned in the body adjacent to the liver, and the electrode deployment apparatus, with an electrode template, is positioned in the delivery catheter in place of the obturator.

FIG. 13 is a perspective view of the ablation apparatus of the invention, with deployed electrodes surrounding a tumor and defining an ablation volume.

FIG. 14 is a perspective view of the tissue ablation apparatus of the invention shown in FIG. 10, positioned in the body adjacent to the liver, with deployed electrodes surrounding a tumor and infusing a solution to the tumor site during a pre-ablation procedure.

FIG. 15 is a perspective view of the tissue ablation apparatus of the invention shown in FIG. 10, illustrating application of RF energy to the tumor.

FIG. 16 is a perspective view of the tissue ablation apparatus of the invention, illustrating the electro-desiccation of the tumor.

FIG. 17 is a perspective view of the tissue ablation apparatus of the invention, illustrating the instillation of solutions to the tumor site during a post-ablation procedure.

FIG. 18 illustrates bipolar ablation between electrodes of the invention.

FIG. 19 illustrates monopolar ablation between electrodes of the invention.

FIG. 20 is a perspective view of an ablation system of the invention, including RF and ultrasound modules, and a monitor.

FIG. 21 is a block diagram of the ablation system of the invention.

FIG. 22(a) is a cross-sectional view of an RF treatment apparatus of the invention.

FIG. 22(b) is a close up cross-sectional view of the distal end of the RF treatment apparatus of FIG. 22(a).

5 FIG. 22(c) is a close up cross-sectional view of the RF treatment apparatus of FIG. 22(a), illustrating the proximal end of the insulation sleeve and a thermocouple associated with the insulation sleeve.

10 FIG. 22(d) is a close up cross-sectional view of the RF treatment apparatus of FIG. 22(a), illustrating the proximal end of the RF treatment apparatus of FIG. 22(a).

FIG. 23 is an exploded view of an RF treatment apparatus of the invention.

15 FIG. 24 is a cross-sectional view of the RF treatment apparatus of the invention illustrating the electrode, insulation sleeve and the associated thermal sensors.

FIG. 25(a) is a perspective view of the RF treatment apparatus of the invention with the infusion device mounted at the distal end of the catheter.

20 FIG. 25(b) is a perspective view of the RF treatment apparatus of FIG. 25(a) illustrating the removal of the catheter, and electrode attached to the distal end of the electrode, from the infusion device which is left remaining in the body.

25 FIG. 26(a) is a perspective view of the RF treatment apparatus of the invention with the electrode mounted at the distal end of the catheter.

30 FIG. 26(b) is a perspective view of the RF treatment apparatus of FIG. 26(a) illustrating the removal of the introducer from the lumen of the electrode.

FIG. 27(a) is a perspective view of the RF treatment apparatus of the invention with the introducer removed from the lumen of the electrode.

35 FIG. 27(b) is a perspective view of the apparatus of FIG. 27(a) illustrating the removal of the electrode from the catheter, leaving behind the insulation sleeve.

FIG. 28(a) is a perspective view of the RF ablation apparatus of the invention with the insulation sleeve positioned in a surrounding relationship to the electrode which is mounted to the distal end of the catheter.

40 FIG. 28(b) is a perspective view of the RF ablation apparatus of FIG. 28(a) illustrating the removal of the insulation sleeve from the electrode.

45 FIG. 28(c) is a perspective view of the insulation sleeve after it is removed from the electrode.

FIG. 29(a) is a perspective view illustrating the attachment of a syringe to the device of FIG. 27(a).

50 FIG. 29(b) is a perspective view of a syringe, containing a fluid medium such as a chemotherapeutic agent, attached to the RF ablation apparatus of FIG. 27(a).

FIG. 30 is a block diagram of an RF treatment system of the invention.

55 FIG. 31(a) is a schematic diagram, consisting of panels 31A-1 and 31A-2, of a power supply suitable for use with the invention.

FIG. 31(b) is a schematic diagram of a voltage sensor suitable useful with the invention.

60 FIG. 31(c) is a schematic diagram of a current sensor suitable useful with the invention.

FIG. 31(d) is a schematic diagram of power computing circuits suitable useful with the invention.

65 FIG. 31(e) is a schematic diagram of an impedance computing circuit suitable useful with the invention.

FIG. 31(f) is a schematic diagram of a power control device suitable useful with the invention.

FIG. 31(g) is a schematic diagram, consisting of panels 31G-1 through 31G-4, of an eight channel temperature measurement suitable for use with the invention.

FIG. 31(h) is a schematic diagram, consisting of panels 31H-1 and 31H-2, of a power and temperature control circuit useful with the invention.

FIG. 32 is a block diagram of an embodiment of the invention which includes a microprocessor.

FIG. 33 illustrates the use of two RF treatment apparatus, such as the one illustrated in FIG. 22(a), that are used in a bipolar mode.

#### DETAILED DESCRIPTION

A tissue ablation apparatus 10 of the invention is illustrated in FIG. 1. Ablation apparatus 10 includes a delivery catheter 12, well known to those skilled in the art, with a proximal end 14 and a distal end 16. Delivery catheter 12 can be of the size of about 5 to 16 F. A handle 18 is removably attached to proximal end 14. An electrode deployment device is at least partially positioned within delivery catheter 12, and includes a plurality of electrodes 20 that are retractable in and out of distal end 16. Electrodes 20 can be of different sizes, shapes and configurations. In one embodiment, they are needle electrodes, with sizes in the range of 27 to 14 gauge. Electrodes 20 are in non-deployed positions while retained in delivery catheter. In the non-deployed positions, electrodes 20 may be in a compacted state, spring loaded, generally confined or substantially straight if made of a suitable memory metal such as nitinol. As electrodes 20 are advanced out of distal end 16 they become distended in a deployed state, which defines an ablative volume, from which tissue is ablated as illustrated more fully in FIG. 2. Electrodes 20 operate either in the bipolar or monopolar modes. When the electrodes are used in the bipolar mode, the ablative volume is substantially defined by the peripheries of the plurality of electrodes 20. In one embodiment, the cross-sectional width of the ablative volume is about 4 cm. However, it will be appreciated that different ablative volumes can be achieved with tissue ablation apparatus 10.

The ablative volume is first determined to define a mass, such as a tumor, to be ablated. Electrodes 20 are placed in a surrounding relationship to a mass or tumor in a predetermined pattern for volumetric ablation. An imaging system is used to first define the volume of the tumor or selected mass. Suitable imaging systems include but are not limited to, ultrasound, computerized tomography (CT) scanning, X-ray film, X-ray fluoroscopy, magnetic resonance imaging, electromagnetic imaging, and the like. The use of such devices to define a volume of a tissue mass or a tumor is well known to those skilled in the art.

With regard to the use of ultrasound, an ultrasound transducer transmits ultrasound energy into a region of interest in a patient's body. The ultrasound energy is reflected by different organs and different tissue types. Reflected energy is sensed by the transducer, and the resulting electrical signal is processed to provide an image of the region of interest. In this way, the ablation volume is then ascertained, and the appropriate electrode deployment device is inserted into delivery catheter 12.

The ablative volume is substantially defined before ablation apparatus 10 is introduced to an ablative treatment position. This assists in the appropriate positioning of ablation apparatus 10. In this manner, the volume of ablated tissue is reduced and substantially limited to a defined mass or tumor, including a certain area surrounding such a tumor,

that is well controlled and defined. A small area around the tumor is ablated in order to ensure that all of the tumor is ablated.

With reference again to FIG. 2, electrode sections 20(a) are in deployed states when they are introduced out of distal end 16. Although electrodes 20 are generally in a non-distended configuration in the non-deployed state while positioned in delivery catheter 12, they can also be distended. Generally, electrode sections 20(b) are in retained positions while they are non-deployed. This is achieved by a variety of methods including but not limited to, (i) the electrodes are pre-sprung, confined in delivery catheter 12, and only become sprung (expanded) as they are released from delivery catheter 12, (ii) the electrodes are made of a memory metal, as explained in further detail below, (iii) the electrodes are made of a selectable electrode material which gives them an expanded shape outside of delivery catheter 12, or (iv) delivery catheter 12 includes guide tubes which serve to confine electrodes 12 within delivery catheter 12 and guide their direction of travel outside of the catheter to form the desired, expanded ablation volume. As shown in FIG. 2, electrodes 20 are pre-sprung while retained in delivery catheter 12. This is the non-deployed position. As they are advanced out of delivery catheter 12 and into tissue, electrodes 20 become deployed and begin to "fan" out from distal end 16, moving in a lateral direction relative to a longitudinal axis of delivery catheter 12. As deployed electrodes 20 continue their advancement, the area of the fan increases and extends beyond the diameter of distal end 16.

Significantly, each electrode 20 is distended in a deployed position, and collectively, the deployed electrodes 20 define a volume of tissue that will be ablated. As previously mentioned, when it is desired to ablate a tumor, either benign or malignant, it is preferable to ablate an area that is slightly in excess to that defined by the exterior surface of the tumor. This improves the chances that all of the tumor is eradicated.

Deployed electrodes 20 can have a variety of different deployed geometries including but not limited to, (i) a first section with a first radius of curvature, and a second section, extending beyond the first section, having a second radius of curvature or a substantially linear geometry, (ii) at least two radii of curvature, (iii) at least one radius of curvature in two or more planes, (iv) a curved section, with an elbow, that is located near distal end 16 of delivery catheter, and a non-curved section that extends beyond the curved section, or (v) a curved section near distal end 16, a first linear section, and then another curved section or a second linear section that is angled with regard to the first linear section. Deployed electrodes 20 need not be parallel with respect to each other. The plurality of deployed electrodes 20, which define a portion of the needle electrode deployment device, can all have the same deployed geometries, i.e., all with at least two radii of curvature, or a variety of geometries, i.e., one with two radii of curvature, a second one with one radius of curvature in two planes, and the rest a curved section near distal end 16 of delivery catheter 12 and a non-curved section beyond the curved section.

A cam 22, or other actuating device, can be positioned within delivery catheter and used to advance and retract electrodes 20 in and out of delivery catheter 12. The actual movement of cam can be controlled at handle 18. Suitable cams are of conventional design, well known to those skilled in the art.

The different geometric configurations of electrodes 20 are illustrated in FIGS. 3 through 6. In FIG. 3, electrode 20 has a first radius of curvature 20(c) and a second radius of curvature 20(d). It can include more than two radii of



curvature. As shown in FIG. 4, electrode 20 has at least one radius of curvature which extends to three planes. In FIG. 5, each electrode has a first curved section 20(e) which is near distal end 16 of delivery catheter 12. A first generally linear section 20(f) extends beyond curved section 20(e), and the two meet at an elbow 20(g). The electrodes 20 can serve as anodes and cathodes. The plurality of electrodes 20 can have linear sections 20(f) that are generally parallel to each other, or they can be non-parallel. FIG. 6 illustrates an electrode 20 that includes a first curved section 20(e) positioned near distal end 16 of delivery catheter 12, a first linear section 20(f), and a second linear section 20(h) which extends beyond first linear section 20(f). Section 20(h) can be linear, curved, or a combination of the two. The plurality of electrodes 20 illustrated in FIG. 6 can have parallel or non-parallel first linear sections 20(f).

In one embodiment of the invention, electrodes 20 are spring-loaded, and compacted in their non-deployed positions. As electrodes 20 are advanced out of distal end 16 of delivery catheter 12, they become deployed and fan out. Electrodes 20 continue this fanning out direction until the resistance of the tissue overcomes the strength of the material forming electrode 20. This causes electrode 20 to bend and move in a direction inward relative to its initial outward fanning direction. The bending creates curved sections 20(c) and 20(d) of FIG. 3, and can also result in the formation of the other electrode 20 geometries of FIGS. 4, 5 and 6. The extent of electrode 20 fan like travel is dependent on the strength of the material from which it is made. Suitable electrode materials include stainless steel, platinum, gold, silver, copper and other electromagnetic conducting materials including conductive polymers. Preferably, electrode 20 is made of stainless steel or nickel titanium and has dimensions of about 27 to 14 gauge.

In one embodiment, electrode 20 is made of a memory metal, such as nickel titanium, commercially available from Raychem Corporation, Menlo Park, Calif. Additionally, a resistive heating element can be positioned in an interior lumen of electrode 20. Resistive heating element can be made of a suitable metal that transfers heat to electrode 20, causing deployed electrode 20 to become deflected when the temperature of electrode 20 reaches a level that causes the electrode material, such as a memory metal, to deflect, as is well known in the art. Not all of electrode 20 need be made of a memory metal. It is possible that only that distal end portion of electrode 20, which is introduced into tissue, be made of the memory metal in order to effect the desired deployed geometrical configuration. Additionally, mechanical devices, including but not limited to steering wires, can be attached to the distal end of electrode 20 to cause it to become directed, deflected and move about in a desired direction about the tissue, until it reaches its final resting position to ablate a tissue mass.

Optionally included in the delivery catheter are one or more guide tubes 24, FIG. 7, which serve to direct the expansion of electrodes 20 in the fan pattern as they are advanced out of distal end 16 of the delivery catheter 12. Guide tubes 24 can be made of stainless steel, spring steel and thermal plastics including but not limited to nylon and polyesters, and are of sufficient size and length to accommodate the electrodes to a specific site in the body.

FIG. 8 illustrates one embodiment of electrode 20 with a sharpened distal end 24. By including a tapered, or piercing end 24, the advancement of electrode 20 through tissue is easier. Electrode 20 can be segmented, and include a plurality of fluid distribution ports 26, which can be evenly formed around all or only a portion of electrode 20. Fluid

distribution ports 26 are formed in electrode 20 when it is hollow and permit the introduction and flow of a variety of fluidic mediums through electrode 20 to a desired tissue site. Such fluidic mediums include, but are not limited to, electrolytic solutions, pastes or gels, as well as chemotherapeutic agents. Examples of suitable conductive gels are carboxymethyl cellulose gels made from aqueous electrolyte solutions such as physiological saline solutions, and the like.

The size of fluid distribution ports 26 can vary, depending on the size and shape of electrode 20. Also associated with electrode 20 is an adjustable insulator sleeve 28 that is slidable along an exterior surface of electrode 20. Insulator sleeve 28 is advanced and retracted along electrode 20 in order to define the size of a conductive surface of electrode 20. Insulator sleeve 28 is actuated at handle 18 by the physician, and its position along electrode 20 is controlled. When electrode 20 moves out of delivery catheter 12 and into tissue, insulator sleeve 28 can be positioned around electrode 20 as it moves its way through the tissue. Alternatively, insulator sleeve 28 can be advanced along a desired length of electrode 20 after electrode 20 has been positioned around a targeted mass to be ablated. Insulator sleeve is thus capable of advancing through tissue along with electrode 20, or it can move through tissue without electrode 20 providing the source of movement. Thus, the desired ablation volume is defined by deployed electrodes 20, as well as the positioning of insulator sleeve 28 on each electrode. In this manner, a very precise ablation volume is created. Suitable materials that form insulator sleeve include but are not limited to nylon, polyimides, other thermoplastics, and the like.

FIG. 9 illustrates a percutaneous application of tissue ablation apparatus 10. Tissue ablation apparatus 10 can be used percutaneously to introduce electrodes 20 to the selected tissue mass or tumor. Electrodes 20 can remain in their non-deployed positions while being introduced percutaneously into the body, and delivered to a selected organ which contains the selected mass to be ablated. Delivery catheter 12 is removable from handle 18. When it is removed, electrode deployment device (the plurality of electrodes 20) can be inserted and removed from delivery catheter 12. An obturator 30 is inserted into delivery catheter 12 initially if a percutaneous procedure is to be performed. As shown in FIG. 10, obturator 30 can have a sharpened distal end 32 that pierces tissue and assists the introduction of delivery catheter 12 to a selected tissue site. The selected tissue site can be a body organ with a tumor or other mass, or the actual tumor itself.

Obturator 30 is then removed from delivery catheter 12 (FIG. 11). Electrode deployment device is then inserted into delivery catheter 12, and the catheter is then reattached to handle 18 (FIG. 12). As illustrated in FIG. 12, electrode deployment device can optionally include an electrode template 34 to guide the deployment of electrodes 20 to a surrounding relationship at an exterior of a selected mass in the tissue.

Electrodes 20 are then advanced out of distal end 16 of delivery catheter 12, and become deployed to form a desired ablative volume which surrounds the mass. In FIG. 13, delivery catheter 12 is positioned adjacent to the liver. Electrode deployment device is introduced into delivery catheter 12 with electrode template 34. Electrode deployment device now pierces the liver, and cam 22 advances electrodes 20 out of delivery catheter 12 into deployed positions. Each individual electrode 20 pierces the liver and travels through it until it is positioned in a surrounding relationship to the tumor. The ablative volume is selectable,

and determined first by imaging the area to be ablated. The ablative volume is defined by the peripheries of all of the deployed electrodes **20** that surround the exterior of the tumor. Once the volume of ablation is determined, then an electrode set is selected which will become deployed to 5 define the ablation volume. A variety of different factors are important in creating an ablation volume. Primarily, different electrodes **20** will have various degrees of deployment, based on type of electrode material, the level of pre-springing of the electrodes and the geometric configuration 10 of the electrodes in their deployed states. Tissue ablation apparatus **10** permits different electrode **20** sets to be inserted into delivery catheter **12**, in order to define a variety of ablation volumes.

Prior to ablation of the tumor, a pre-ablation step can be performed. A variety of different solutions, including electrolytic solutions such as saline, can be introduced to the tumor site, as shown in FIG. **14**. FIG. **15** illustrates the application of RF energy to the tumor. Electrode insulator **28** is positioned on portions of electrodes **20** where there will be no ablation. This further defines the ablation volume. The actual electro-desiccation of the tumor, or other targeted masses or tissues, is shown in FIG. **16**. Again, deployed electrodes **20**, with their electrode insulators **28** positioned along sections of the electrodes, define the ablation volume, and the resulting amount of mass that is desiccated. 20

Optionally following desiccation, electrodes **20** can introduce a variety of solutions in a post-ablation process. This step is illustrated in FIG. **17**. Suitable solutions include but are not limited to chemotherapeutic agents.

FIG. **8** illustrates tissue ablation apparatus **10** operated in a bipolar mode. Its monopolar operation is shown in FIG. **19**. Each of the plurality of electrodes **20** can play different roles in the ablation process. There can be polarity shifting between the different electrodes. 25

A tissue ablation system **36**, which can be modular, is shown in FIG. **20** and can include a display **38**. Tissue ablation system **36** can also include an RF energy source, microwave source, ultrasound source, visualization devices such as cameras and VCR's, electrolytic and chemotherapeutic solution sources, and a controller which can be used to monitor temperature or impedance. One of the deployed electrodes **20** can be a microwave antenna coupled to a microwave source. This electrode can initially be coupled to RF power source **42** and is then switched to the microwave source 45

Referring now to FIG. **21**, a power supply **40** delivers energy into RF power generator (source) **42** and then to electrodes **20** of tissue ablation apparatus **10**. A multiplexer **46** measures current, voltage and temperature (at numerous temperature sensors which can be positioned on electrodes **20**). Multiplexer **46** is driven by a controller **48**, which can be a digital or analog controller, or a computer with software. When controller **48** is a computer, it can include a CPU coupled through a system bus. This system can include a keyboard, disk drive, or other non-volatile memory systems, a display, and other peripherals, as known in the art. Also coupled to the bus are a program memory and a data memory. 50

An operator interface **50** includes operator controls **52** and display **38**. Controller **48** is coupled to imaging systems, including ultrasound transducers, temperature sensors, and viewing optics and optical fibers, if included.

Current and voltage are used to calculate impedance. Diagnostics are done through ultrasound, CT scanning, or other methods known in the art. Imaging can be performed before, during and after treatment. 65

Temperature sensors measure voltage and current that is delivered. The output of these sensors is used by controller **48** to control the delivery of RF power. Controller **48** can also control temperature and power. The amount of RF energy delivered controls the amount of power. A profile of power delivered can be incorporated in controller **38**, as well as a pre-set amount of energy to be delivered can also be profiled.

Feedback can be the measurement of impedance or temperature, and occurs either at controller **48** or at electromagnetic energy source **42**, e.g., RF or microwave, if it incorporates a controller. For impedance measurement, this can be achieved by supplying a small amount of non-ablation RF energy. Voltage and current are then measured.

Circuitry, software and feedback to controller **48** result in process control and are used to change, (i) power, including RF, ultrasound, and the like, (ii) the duty cycle (on-off and wattage), (iii) monopolar or bipolar energy delivery, (iv) and electrolytic solution delivery, flow rate and pressure and (v) determine when ablation is completed through time, temperature and/or impedance. These process variables can be controlled and varied based on temperature monitored at multiple sites, and impedance to current flow that is monitored, indicating changes in current carrying capability of the tissue during the ablative process. 25

Referring now to FIGS. **22(a)**, **22(b)**, **22(c)**, **22** and **24** an RF treatment apparatus **110** is illustrated which can be used to ablate a selected tissue mass, including but not limited to a tumor, or treat the mass by hyperthermia. Treatment apparatus **110** includes a catheter **112** with a catheter lumen in which different devices are introduced and removed. An insert **114** is removably positioned in the catheter lumen. Insert **114** can be an introducer, a needle electrode, and the like. 30

When insert **114** is an introducer, including but not limited to a guiding or delivery catheter, it is used as a means for puncturing the skin of the body, and advancing catheter **112** to a desired site. Alternatively, insert **114** can be both an introducer and an electrode adapted to receive RF current for tissue ablation and hyperthermia. 40

If insert **114** is not an electrode, then a removable electrode **116** is positioned in insert **114** either during or after treatment apparatus **110** has been introduced percutaneously to the desired tissue site. Electrode **116** has an electrode distal end that advances out of an insert distal end. In this deployed position, RF energy is introduced to the tissue site along a conductive surface of electrode **116**. 45

Electrode **116** can be included in treatment apparatus **110**, and positioned within insert **114**, while treatment apparatus **110** is being introduced to the desired tissue site. The distal end of electrode **116** can have substantially the same geometry as the distal end of insert **114** so that the two ends are essentially flush. Distal end of electrode **116**, when positioned in insert **114** as it is introduced through the body, serves to block material from entering the lumen of insert **114**. The distal end of electrode **116** essentially can provide a plug type of function. 55

Electrode **116** is then advanced out of a distal end of insert **114**, and the length of an electrode conductive surface is defined, as explained further in this specification. Electrode **116** can advance straight, laterally or in a curved manner out of distal end of insert **114**. Ablative or hyperthermia treatment begins when two electrodes **116** are positioned closely enough to effect bipolar treatment of the desired tissue site or tumor. A return electrode attaches to the patients skin. Operating in a bipolar mode, selective ablation of the tumor is achieved. However, it will be appreciated that the present 65

invention is suitable for treating, through hyperthermia or ablation, different sizes of tumors or masses. The delivery of RF energy is controlled and the power at each electrode is maintained, independent of changes in voltage or current. Energy is delivered slowly at low power. This minimizes desiccation of the tissue adjacent to the electrodes **116**, permitting a wider area of even ablation. In one embodiment, 8 to 14 W of RE energy is applied in a bipolar mode for 10 to 25 minutes. An ablation area between electrodes **116** of about 2 to 6 cm is achieved.

Treatment apparatus **110** can also include a removable introducer **118** which is positioned in the insert lumen instead of electrode **116**. Introducer **118** has an introducer distal end that also serves as a plug, to minimize the entrance of material into the insert distal end as it advances through a body structure. Introducer **118** is initially included in treatment apparatus, and is housed in the lumen of insert **114**, to assist the introduction of treatment apparatus **110** to the desired tissue site. Once treatment apparatus **110** is at the desired tissue site, then introducer **118** is removed from the insert lumen, and electrode **116** is substituted in its place. In this regard, introducer **118** and electrode **116** are removable to and from insert **114**.

Also included is an insulator sleeve **120** coupled to an insulator slide **122**. Insulator sleeve **120** is positioned in a surrounding relationship to electrode **116**. Insulator slide **122** imparts a slidable movement of the insulator sleeve along a longitudinal axis of electrode **116** in order to define an electrode conductive surface that begins at an insulator sleeve distal end.

A thermal sensor **124** can be positioned in or on electrode **116** or introducer **118**. A thermal sensor **126** is positioned on insulator sleeve **120**. In one embodiment, thermal sensor **124** is located at the distal end of introducer **118**, and thermal sensor **126** is located at the distal end of insulator sleeve **120**, at an interior wall which defines a lumen of insulator sleeve **120**. Suitable thermal sensors include a T type thermocouple with copper constantene, J type, E type, K type, thermistors, fiber optics, resistive wires, thermocouples IR detectors, and the like. It will be appreciated that sensors **124** and **126** need not be thermal sensors.

Catheter **112**, insert **114**, electrode **116** and introducer **118** can be made of a variety of materials. In one embodiment, catheter **112** is black anodized aluminum, 0.5 inch, electrode **116** is made of stainless steel, preferably 18 gauge, introducer **118** is made of stainless steel, preferably 21 gauge, and insulator sleeve **120** is made of polyimide.

By monitoring temperature, RF power delivery can be accelerated to a predetermined or desired level. Impedance is used to monitor voltage and current. The readings of thermal sensors **124** and **126** are used to regulate voltage and current that is delivered to the tissue site. The output for these sensors is used by a controller, described further in this specification, to control the delivery of RF energy to the tissue site. Resources, which can be hardware and/or software, are associated with an RF power source, coupled to electrode **116** and the return electrode. The resources are associated with thermal sensors **124** and **125**, the return electrode as well as the RF power source for maintaining a selected power at electrode **116** independent of changes in voltage or current. Thermal sensors **124** and **126** are of conventional design, including but not limited to thermistors, thermocouples, resistive wires, and the like.

Electrode **116** is preferably hollow and includes a plurality of fluid distribution ports **128** from which a variety of fluids can be introduced, including electrolytic solutions, chemotherapeutic agents, and infusion media.

A specific embodiment of the RF treatment device **110** is illustrated in FIG. **23**. Included is an electrode locking cap **128**, an RF coupler **310**, an introducer locking cap **312**, insulator slide **122**, catheter body **112**, insulator retainer cap **134**, insulator locking sleeve **136**, a luer connector **138**, an insulator elbow connector **140**, an insulator adjustment screw **142**, a thermocouple cable **144** for thermal sensor **126**, a thermocouple cable **46** for thermal sensor **124** and a luer retainer **148** for an infusion device **150**.

In another embodiment of RF treatment apparatus **110**, electrode **116** is directly attached to catheter **112** without insert **114**. Introducer **118** is slidably positioned in the lumen of electrode **116**. Insulator sleeve **120** is again positioned in a surrounding relationship to electrode **116** and is slidably moveable along its surface in order to define the conductive surface. Thermal sensors **124** and **126** are positioned at the distal ends of introducer **118** and insulator sleeve **120**. Alternatively, thermal sensor **124** can be positioned on electrode **116**, such as at its distal end. The distal ends of electrode **116** and introducer **118** can be sharpened and tapered. This assists in the introduction of RE treatment apparatus to the desired tissue site. Each of the two distal ends can have geometries that essentially match. Additionally, distal end of introducer **118** can be an essentially solid end in order to prevent the introduction of material into the lumen of catheter **116**.

In yet another embodiment of RF treatment apparatus **110**, infusion device **150** remains implanted in the body after catheter **112**, electrode **116** and introducer **118** are all removed. This permits a chemotherapeutic agent, or other infusion medium, to be easily introduced to the tissue site over an extended period of time without the other devices of RF treatment apparatus **110** present. These other devices, such as electrode **116**, can be inserted through infusion device **150** to the tissue site at a later time for hyperthermia or ablation purposes. Infusion device **150** has an infusion device lumen and catheter **112** is at least partially positioned in the infusion device lumen. Electrode **116** is positioned in the catheter lumen, in a fixed relationship to catheter **112**, but is removable from the lumen. Insulator sleeve **120** is slidably positioned along a longitudinal axis of electrode **116**. Introducer **118** is positioned in a lumen of electrode **116** and is removable therefrom. A power source is coupled to electrode **116**. Resources are associated with thermal sensors **124** and **126**, voltage and current sensors that are coupled to the RF power source for maintaining a selected power at electrode **116**.

The distal end of RF treatment apparatus **110** is shown in FIG. **22(b)**. Introducer **118** is positioned in the lumen of electrode **116**, which can be surrounded by insulator sleeve **120**, all of which are essentially placed in the lumen of infusion device **150**. It will be appreciated, however, that in FIG. **22(b)** insert **114** can take the place of electrode **116**, and electrode **116** can be substituted for introducer **118**.

The distal end of insulator sleeve **120** is illustrated in FIG. **22(c)**. Thermal sensor **126** is shown as being in the form of a thermocouple. In FIG. **22(d)**, thermal sensor **124** is also illustrated as a thermocouple that extends beyond a distal end of introducer **118**, or alternative a distal end of electrode **116**.

Referring now to FIGS. **25(a)** and **25(b)**, infusion device **150** is attached to the distal end of catheter **112** and retained by a collar. The collar is rotated, causing catheter **112** to become disengaged from infusion device **150**. Electrode **116** is attached to the distal end of catheter **112**. Catheter **112** is pulled away from infusion device **150**, which also removes electrode **116** from infusion device **150**. Thereafter, only

## 15

infusion device **150** is retained in the body. While it remains placed, chemotherapeutic agents can be introduced through infusion device **150** to treat the tumor site. Additionally, by leaving infusion device **150** in place, catheter **112** with electrode **116** can be reintroduced back into the lumen of infusion device **150** at a later time for additional RF treatment in the form of ablation or hyperthermia.

In FIG. **26(a)**, electrode **116** is shown as attached to the distal end of catheter **112**. Introducer **118** is attached to introducer locking cap **132** which is rotated and pulled away from catheter **112**. As shown in FIG. **26(b)** this removes introducer **118** from the lumen of electrode **116**.

Referring now to FIG. **27(a)**, electrode **116** is at least partially positioned in the lumen of catheter **112**. Electrode locking cap **128** is mounted at the proximal end of catheter **112**, with the proximal end of electrode **116** attaching to electrode locking cap **128**. Electrode locking cap **128** is rotated and unlocks from catheter **112**. In FIG. **27(b)**, electrode locking cap **128** is then pulled away from the proximal end of catheter **112**, pulling with it electrode **116** which is then removed from the lumen of catheter **112**. After electrode **116** is removed from catheter **112**, insulator sleeve **120** is locked on catheter **112** by insulator retainer cap **134**.

In FIG. **28(a)**, insulator retainer cap **134** is unlocked and removed from catheter **112**. As shown in FIG. **28(b)**, insulator sleeve **120** is then slid off of electrode **116**. FIG. **28(c)** illustrates insulator sleeve **120** completely removed from catheter **112** and electrode **116**.

Referring now to FIGS. **29(a)** and **29(b)**, after introducer **118** is removed from catheter **112**, a fluid source, such as syringe **151**, delivering a suitable fluid, including but not limited to a chemotherapeutic agent, attaches to luer connector **138** at the proximal end of catheter **112**. Chemotherapeutic agents are then delivered from syringe **151** through electrode **116** to the tumor site. Syringe **151** is then removed from catheter **112** by imparting a rotational movement of syringe **151** and pulling it away from catheter **112**. Thereafter, electrode **116** can deliver further RF power to the tumor site. Additionally, electrode **116** and catheter **112** can be removed, leaving only infusion device **150** in the body. Syringe **151** can then be attached directly to infusion device **150** to introduce a chemotherapeutic agent to the tumor site. Alternatively, other fluid delivery devices can be coupled to infusion device **150** in order to have a more sustained supply of chemotherapeutic agents to the tumor site.

Once chemotherapy is completed, electrode **116** and catheter **112** can be introduced through infusion device **150**. RF power is then delivered to the tumor site. The process begins again with the subsequent removal of catheter **112** and electrode **116** from infusion device **150**. Chemotherapy can then begin again. Once it is complete, further RF power can be delivered to the tumor site. This process can be repeated any number of times for an effective multi-modality treatment of the tumor site.

Referring now to FIG. **30**, a block diagram of power source **152** is illustrated. Power source **152** includes a power supply **154**, power circuits **156**, a controller **158**, a power and impedance calculation device **160**, a current sensor **162**, a voltage sensor **164**, a temperature measurement device **166** and a user interface and display **168**.

FIGS. **31(a)** through **31(g)** are schematic diagrams of power supply **154**, voltage sensor **164**, current sensor **162**, power computing circuit associated with power and impedance calculation device **160**, impedance computing circuit associated with power and impedance calculation device **160**, power control circuit of controller **158** and an eight

## 16

channel temperature measurement circuit of temperature measure device **166**, respectively.

Current delivered through each electrode **116** is measured by current sensor **162**. Voltage between the electrodes **116** is measured by voltage sensor **164**. Impedance and power are then calculated at power and impedance calculation device **160**. These values can then be displayed at user interface **168**. Signals representative of power and impedance values are received by controller **158**.

A control signal is generated by controller **158** that is proportional to the difference between an actual measured value, and a desired value. The control signal is used by power circuits **156** to adjust the power output in an appropriate amount in order to maintain the desired power delivered at the respective electrode **116**.

In a similar manner, temperatures detected at thermal sensors **124** and **126** provide feedback for maintaining a selected power. The actual temperatures are measured at temperature measurement device **166**, and the temperatures are displayed at user interface **168**. Referring now to FIG. **31(h)**, a control signal is generated by controller **159** that is proportional to the difference between an actual measured temperature, and a desired temperature. The control signal is used by power circuits **157** to adjust the power output in an appropriate amount in order to maintain the desired temperature delivered at the respective sensor **124** or **126**.

Controller **158** can be a digital or analog controller, or a computer with software. When controller **158** is a computer it can include a CPU coupled through a system bus. On this system can be a keyboard, a disk drive, or other non-volatile memory systems, a display, and other peripherals, as are known in the art. Also coupled to the bus are a program memory and a data memory.

User interface **168** includes operator controls and a display. Controller **158** can be coupled to imaging systems, including but not limited to ultrasound, CT scanners and the like.

Current and voltage are used to calculate impedance. Diagnostics can be performed optically, with ultrasound, CT scanning, and the like. Diagnostics are performed either before, during and after treatment.

The output of current sensor **162** and voltage sensor **164** is used by controller **158** to maintain the selected power level at electrodes **116**. The amount of RF energy delivered controls the amount of power. A profile of power delivered can be incorporated in controller **158**, and a pre-set amount of energy to be delivered can also be profiled.

Circuitry, software and feedback to controller **158** result in process control, and the maintenance of the selected power that is independent of changes in voltage or current, and are used to change, (i) the selected power, including RF, ultrasound and the like, (ii) the duty cycle (on-off and wattage), (iii) bipolar energy delivery and (iv) fluid delivery, including chemotherapeutic agents, flow rate and pressure. These process variables are controlled and varied, while maintaining the desired delivery of power independent of changes in voltage or current, based on temperatures monitored at thermal sensors **124** and **126** at multiple sites.

Controller **158** can be microprocessor controlled. Referring now to FIG. **32**, current sensor **162** and voltage sensor **164** are connected to the input of an analog amplifier **170**. Analog amplifier **170** can be a conventional differential amplifier circuit for use with thermal sensors **124** and **126**. The output of analog amplifier **170** is sequentially connected by an analog multiplexer **172** to the input of analog-to-digital converter **174**. The output of analog amplifier **170** is a voltage which represents the respective sensed tempera-

## 17

tures. Digitized amplifier output voltages are supplied by analog-to-digital converter 174 to a microprocessor 176. Microprocessor 176 may be a type 68HCII available from Motorola. However, it will be appreciated that any suitable microprocessor or general purpose digital or analog computer can be used to calculate impedance or temperature.

Microprocessor 176 sequentially receives and stores digital representations of impedance and temperature. Each digital value received by microprocessor 176 corresponds to different temperatures and impedances.

Calculated power and impedance values can be indicated on user interface 168. Alternatively, or in addition to the numerical indication of power or impedance, calculated impedance and power values can be compared by microprocessor 176 with power and impedance limits. When the values exceed predetermined power or impedance values, a warning can be given on interface 168, and additionally, the delivery of RF energy can be reduced, modified or interrupted. A control signal from microprocessor 176 can modify the power level supplied by power supply 154.

An imaging system can be used to first define the volume of the tumor or selected mass. Suitable imaging systems include but are not limited to, ultrasound, CT scanning, X-ray film, X-ray fluoroscope, magnetic resonance imaging, electromagnetic imaging and the like. The use of such devices to define a volume of a tissue mass or a tumor is well known to those skilled in the art.

Specifically with ultrasound, an ultrasound transducer transmits ultrasound energy into a region of interest in a patient's body. The ultrasound energy is reflected by different organs and different tissue types. Reflected energy is sensed by the transducer, and the resulting electrical signal is processed to provide an image of the region of interest. In this way, the volume to be ablated is ascertained.

Ultrasound is employed to image the selected mass or tumor. This image is then imported to user interface 168. The placement of electrodes 116 can be marked, and RF energy delivered to the selected site with prior treatment planning. Ultrasound can be used for real time imaging. Tissue characterization of the imaging can be utilized to determine how much of the tissue is heated. This process can be monitored. The amount of RF power delivered is low, and the ablation or hyperthermia of the tissue is slow. Desiccation of tissue between the tissue and each needle 116 is minimized by operating at low power.

The following examples illustrate the use of the invention with two RF treatment apparatus with two electrodes shown in FIG. 33, or a pair of two electrodes, that are used in a bipolar mode to ablate tissue.

## EXAMPLE 1

Exposed electrode length:	1.5 cm
Distance between electrodes:	1.5 cm
Power setting:	5 W
Ablation time:	10 min.
<u>Lesion size:</u>	
width:	2 cm
length:	1.7 cm
depth:	1.5 cm

## 18

## EXAMPLE 2

Exposed electrode length:	1.5
Distance between electrodes:	2.0
Power setting:	7.0
Ablation time:	10 min.
<u>Lesion size:</u>	
width:	2.8 cm
length:	2.5 cm
depth:	2.2 cm

## EXAMPLE 3

Exposed electrode length:	2.5 cm
Distance between electrodes:	2.0 cm
Power setting:	10 W
Ablation time:	10 min
<u>Lesion size:</u>	
width:	3.0 cm
length:	2.7 cm
depth:	1.7 cm

## EXAMPLE 4

Exposed electrode length:	2.5 cm
Distance between electrodes:	2.5 cm
Power setting:	8 W
Ablation time:	10 min.
<u>Lesion size:</u>	
width:	2.8 cm
length:	2.7 cm
depth:	3.0 cm

## EXAMPLE 5

Exposed electrode length:	2.5 cm
Distance between electrodes:	2.5 cm
Power setting:	8 W
Ablation time:	12 min.
<u>Lesion size:</u>	
width:	2.8 cm
length:	2.8 cm
depth:	2.5 cm

## EXAMPLE 6

Exposed electrode length:	2.5 cm
Distance between electrodes:	1.5 cm
Power setting:	8 W
Ablation time:	14 min.

-continued

---

<u>Lesion size:</u>	
width:	3.0 cm
length:	3.0 cm
depth:	2.0 cm

---

EXAMPLE 7

---

With return electrode at	1.5 cm
Exposed electrode length:	2.5 cm
Distance between electrodes:	2.5 cm
Power setting:	8 W
Ablation time:	10 min.
<u>Lesion size:</u>	
width:	3.0 cm
length:	3.0 cm
depth:	3.0 cm

---

EXAMPLE 8

---

Exposed electrode length:	2.5 cm
Distance between electrodes:	2.5 cm
Power setting:	10 W
Ablation time:	12 min.
<u>Lesion size:</u>	
width:	3.5 cm
length:	3.0 cm
depth:	2.3 cm

---

EXAMPLE 9

---

Exposed electrode length:	2.5 cm
Distance between electrodes:	2.5 cm
Power setting:	11 W
Ablation time:	11 min.
<u>Lesion size:</u>	
width:	3.5 cm
length:	3.5 cm
depth:	2.5 cm

---

EXAMPLE 10

---

Exposed electrode length:	3.0 cm
Distance between electrodes:	3.0 cm
Power setting:	11 W
Ablation time:	15 min.
<u>Lesion size:</u>	
width:	4.3 cm
length:	3.0 cm
depth:	2.2 cm

---

EXAMPLE 11

---

Exposed electrode length:	3.0 cm
Distance between electrodes:	2.5 cm
Power setting:	11 W
Ablation time:	11 min.
<u>Lesion size:</u>	
width:	4.0 cm
length:	3.0 cm
depth:	2.2 cm

---

EXAMPLE 12

---

Exposed electrode length:	4.0 cm
Distance between electrodes:	2.5 cm
Power setting:	11 W
Ablation time:	16 min.
<u>Lesion size:</u>	
width:	3.5 cm
length:	4.0 cm
depth:	2.8 cm

---

EXAMPLE 13

---

Two pairs of electrodes (Four electrodes)	
Exposed electrode length:	2.5 cm
Distance between electrodes:	2.5 cm
Power setting:	12 W
Ablation time:	16 min.
<u>Lesion size:</u>	
width:	3.5 cm
length:	3.0 cm
depth:	4.5 cm

---

EXAMPLE 14

---

Two pairs of electrodes (Four electrodes)	
Exposed electrode length:	2.5 cm
Distance between electrodes:	2.5 cm
Power setting:	15 W
Ablation time:	14 min.
<u>Lesion size:</u>	
width:	4.0 cm
length:	3.0 cm
depth:	5.0 cm

---

The foregoing description of preferred embodiments of the present invention has been provided for the purposes of illustration and description. It is not intended to be exhaustive or to limit the invention to the precise forms disclosed. Obviously, many modifications, variations and different combinations of embodiments will be apparent to practitioners skilled in this art. Also, it will be apparent to the skilled

## 21

practitioner that elements from one embodiment can be recombined with one or more other embodiments. It is intended that the scope of the invention be defined by the following claims and their equivalents.

What is claimed is:

1. A tissue ablation apparatus for use with a microwave power source, comprising:

an elongated delivery device including a distal portion sufficiently sharp to penetrate tissue and a proximal portion; and;

an energy delivery device including at least one microwave electrode having a tissue piercing distal portion, and (i) being positionable in the elongated delivery device in a compacted state and preformed to assume a curved shape when deployed, and (ii) exhibiting a changing direction of travel when advanced from the elongated delivery device to a selected tissue site, said at least one electrode being configured to be operatively connected to the microwave energy source; and

at least one of the elongated delivery device, or the at least one electrode having an infusion lumen for fluid delivery therethrough.

2. The apparatus of claim 1, wherein the at least one infusion port is positioned at a distal portion of the elongated delivery device.

3. The apparatus of claim 2, where said at least one infusion port comprises a series of end region infusion ports positioned at the distal end of at least one of the elongated delivery device or the at least one electrode.

4. The apparatus of claim 1, further comprising: a rigid electrode advancement member coupled to the energy delivery device.

5. The apparatus of claim 1, further comprising: an insulator positioned in a surrounding relationship to at least a portion of the elongated delivery device.

6. The apparatus of claim 1, further comprising:

a sensor coupled to at least one of the elongated member, or the at least one electrode.

7. The apparatus of claim 6, wherein the sensor is a thermal sensor.

8. The apparatus of claim 6, further comprising a feedback control resource coupled to the sensor and adapted to be coupled to at least one of the microwave energy source and a fluid delivery device coupled to the infusion lumen such that the feedback control resource generates a signal to at least one of the microwave energy source and the fluid delivery device for controlling process variables.

9. The apparatus of claim 8, when the feedback control resource is coupled to the microwave energy source, the process variables are at least one of (i) a power level, (ii) a duty cycle, and (iii) an energy delivery.

## 22

10. The apparatus of claim 8, when the controller is coupled to the fluid delivery device, the process variables are at least one of (i) a fluid delivery flow rate, (ii) a fluid pressure, and (iii) delivery of fluid.

11. The apparatus of claim 1, wherein said elongated delivery device is an electrode configured to be operatively coupled to an energy source.

12. The apparatus of claim 1, wherein said elongated delivery device is an electrode configured to be operatively coupled to a RF energy source.

13. The apparatus of claim 1, further comprising a controller adapted to be operatively coupled to at least one of the microwave energy source and operatively coupled to a fluid delivery device coupled to the infusion lumen such that the controller generates a signal to at least one of the microwave energy source and the fluid delivery device for controlling process variables.

14. The apparatus of claim 13, wherein the controller includes at least one of (i) a digital controller, (ii) an analog controller, and (iii) a programmed computer.

15. The apparatus of claim 13, wherein the process variables are at least one of (i) a power level; (ii) a duty cycle; (iii) an energy delivery; (iv) a fluid delivery flow rate or (v) a fluid pressure.

16. A tissue ablation system, comprising:

an ablation apparatus comprising

an elongated delivery device including a distal portion sufficiently sharp to penetrate tissue and a proximal portion,

an energy delivery device including at least one electrode having a tissue piercing distal portion, and (i) being positionable in the elongated delivery device in a compacted state and preformed to assume a curved shape when deployed, and (ii) exhibiting a changing direction of travel when advanced from the elongated delivery device to a selected tissue site, said at least one electrode being configured to be operatively connected to a microwave energy source; and

at least one of the elongated delivery device, or the at least one electrode having an infusion lumen for fluid delivery therethrough;

a microwave energy source operatively coupled to the ablation apparatus for delivery of microwave energy to the at least one electrode; and

a fluid reservoir operatively connected to the ablation apparatus for fluid delivery to at least one of the elongated delivery or the at least one electrode.

\* \* \* \* \*