

US007110794B1

(12) **United States Patent**
Iinuma

(10) **Patent No.:** **US 7,110,794 B1**
(45) **Date of Patent:** **Sep. 19, 2006**

(54) **ADAPTIVE ARRAY APPARATUS AND
COMPENSATION METHOD FOR
COMPENSATING A PHASE DIFFERENCE
USED FOR GENERATING A DIRECTIVITY
RESPONSE PATTERN**

6,058,318 A * 5/2000 Kobayakawa et al. ... 455/562.1
6,243,412 B1 * 6/2001 Fukawa 375/219

FOREIGN PATENT DOCUMENTS

EP	0 837 523 A2	4/1998
JP	59-45582	3/1984
JP	61117902 A	6/1986
JP	01154604 A	6/1989
JP	06216625 A	8/1994
JP	9-138270	5/1997
JP	10-126139	5/1998

(75) Inventor: **Toshinori Iinuma**, Gifu (JP)

(73) Assignee: **Sanyo Electric Co., Ltd.**, Osaka-fu (JP)

(*) Notice: Subject to any disclaimer, the term of this patent is extended or adjusted under 35 U.S.C. 154(b) by 0 days.

OTHER PUBLICATIONS

“Spectral efficiency improvement by base station antenna pattern control for land mobile cellular systems,” The Institute of Electronics, Information and Communication Engineers; Technical Report of IEICE, MW93-25, RCS93-8 (May 1993), pp. 55-60, No Month Listed.

International Publication No. WO98/56121, published Dec. 10, 1998 & EP 0 961 416 A, published Dec. 1, 1999.

* cited by examiner

Primary Examiner—Temica Beamer

Assistant Examiner—Joy K. Contee

(74) *Attorney, Agent, or Firm*—Arent Fox, PLLC

(21) Appl. No.: **09/856,499**

(22) PCT Filed: **Dec. 15, 1998**

(86) PCT No.: **PCT/JP98/05652**

§ 371 (c)(1),
(2), (4) Date: **Jun. 13, 2001**

(87) PCT Pub. No.: **WO00/36701**

PCT Pub. Date: **Jun. 22, 2000**

(51) **Int. Cl.**
H04M 1/00 (2006.01)

(52) **U.S. Cl.** **455/562.1; 342/373**

(58) **Field of Classification Search** 455/423,
455/67.16; 375/219, 285, 232; 342/373,
342/174, 372, 42, 50

See application file for complete search history.

(57) **ABSTRACT**

An adaptive array apparatus includes a control unit **50** and a plurality of radio units **10~40** that each have a modulator **11**, a transmission circuit **12**, a switch **13**, a phase detecting unit **14**, a reception circuit **15**, and a demodulator **16**. For each radio unit **10~40**, the control unit **50** compensates a phase amount for generating a directivity pattern used for an output signal according to a difference in phase shift amounts between a transmission subsystem and a reception subsystem.

(56) **References Cited**

U.S. PATENT DOCUMENTS

5,546,090 A * 8/1996 Roy, III et al. 342/174
5,767,806 A * 6/1998 Watanabe et al. 342/373

9 Claims, 7 Drawing Sheets

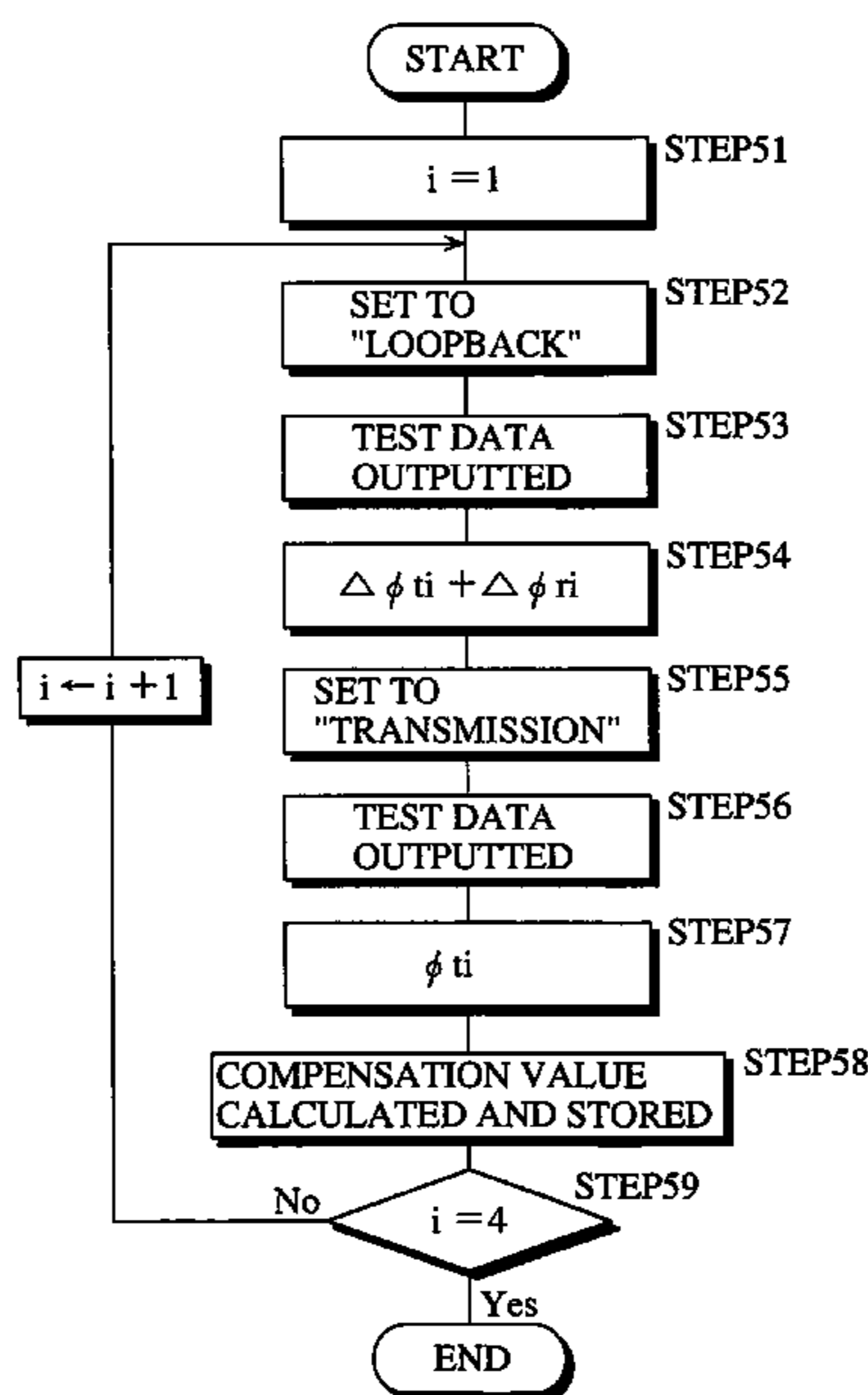

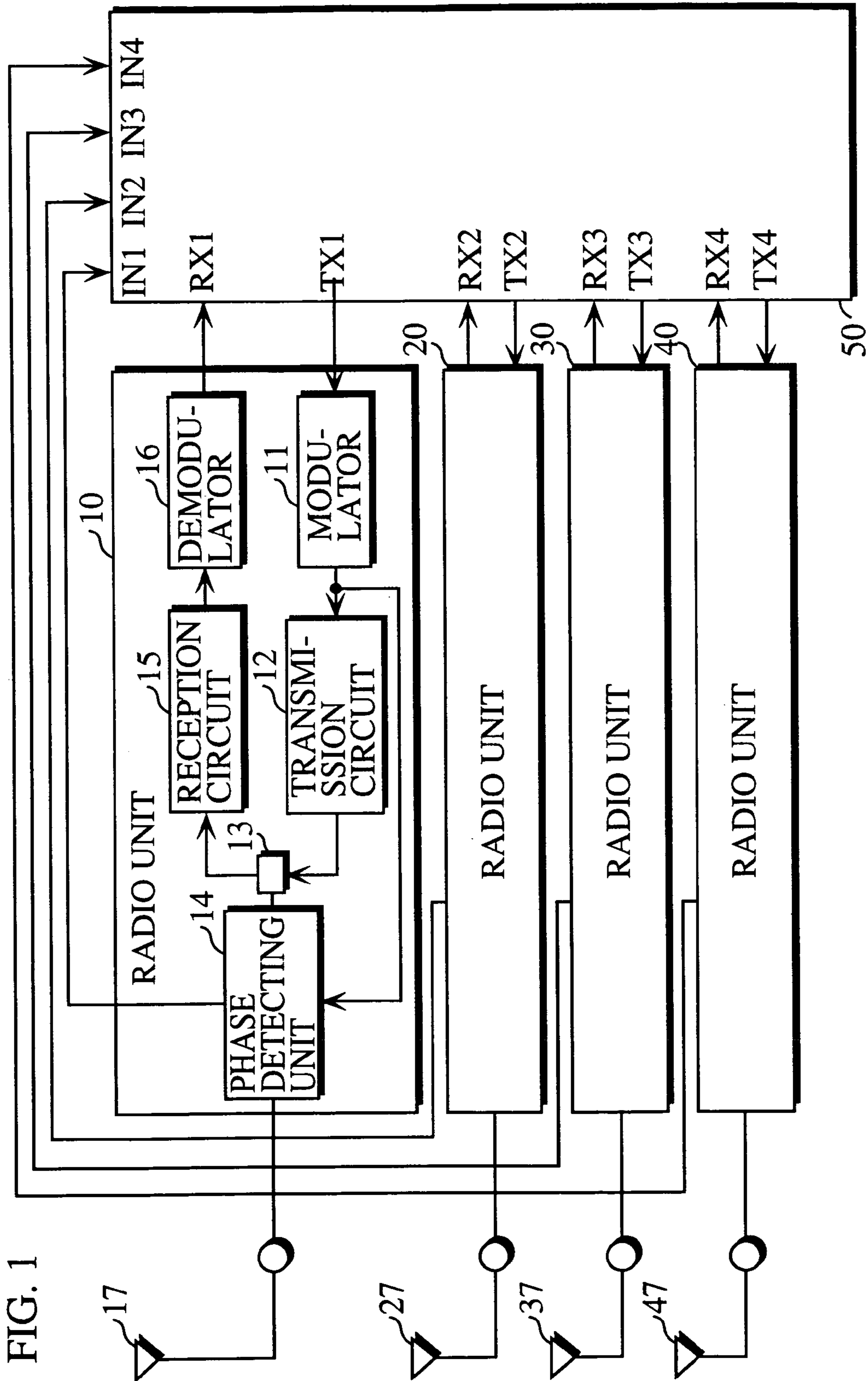

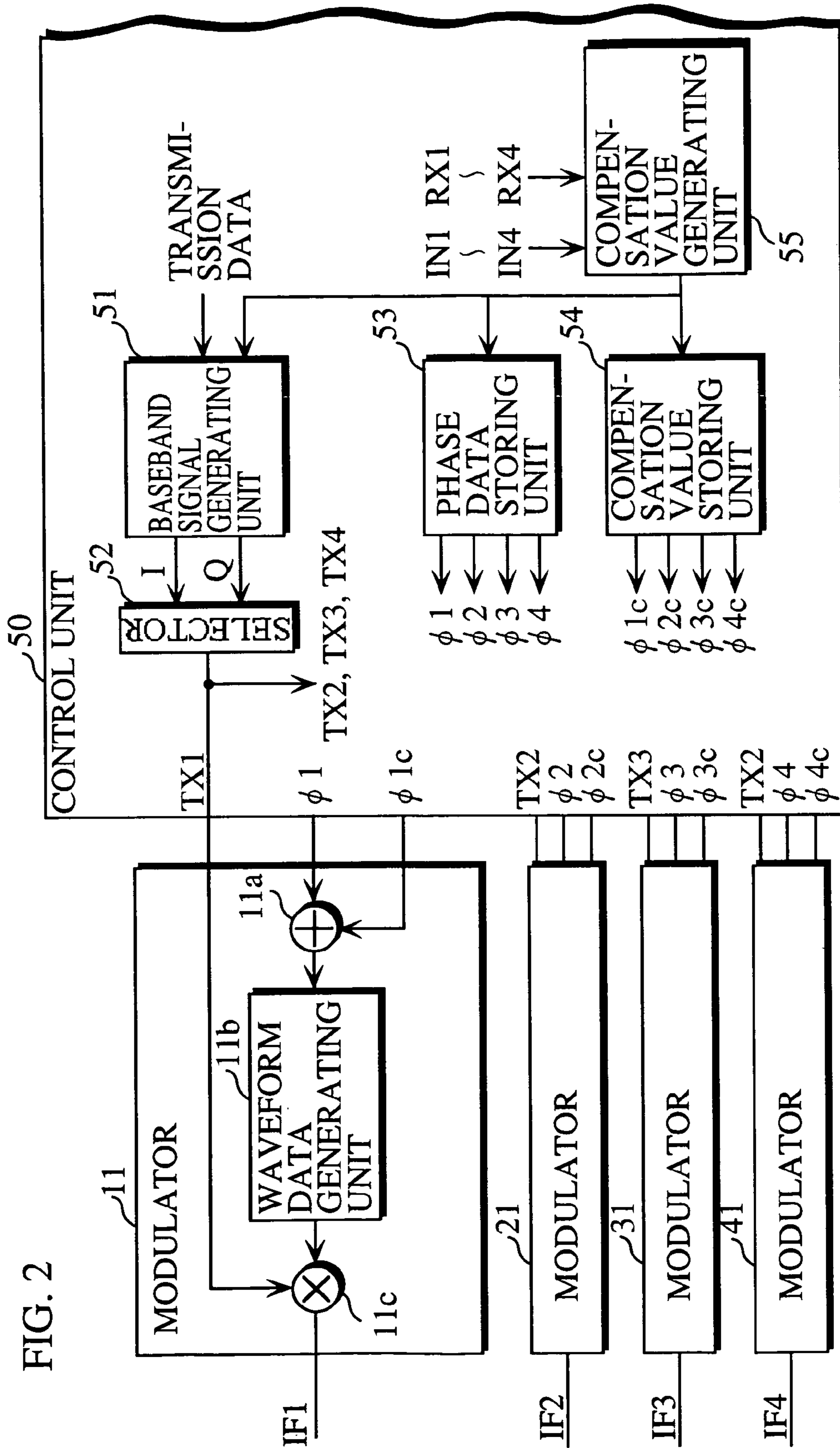

FIG. 2

FIG. 3

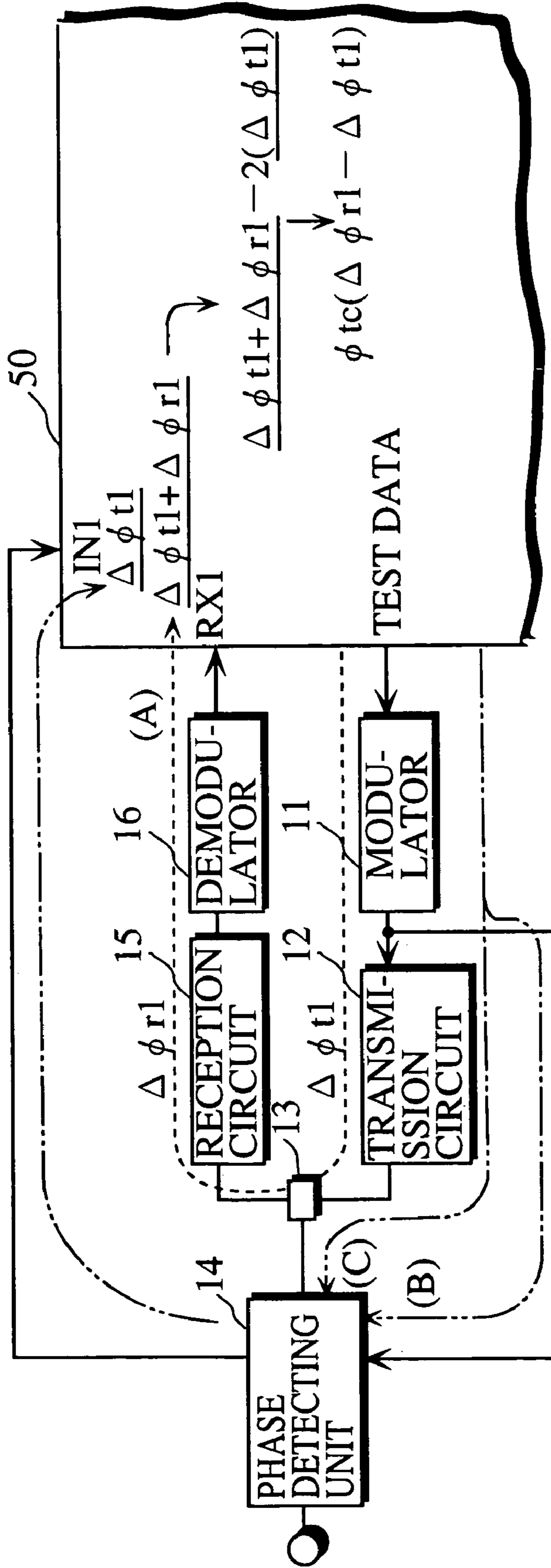

FIG. 4

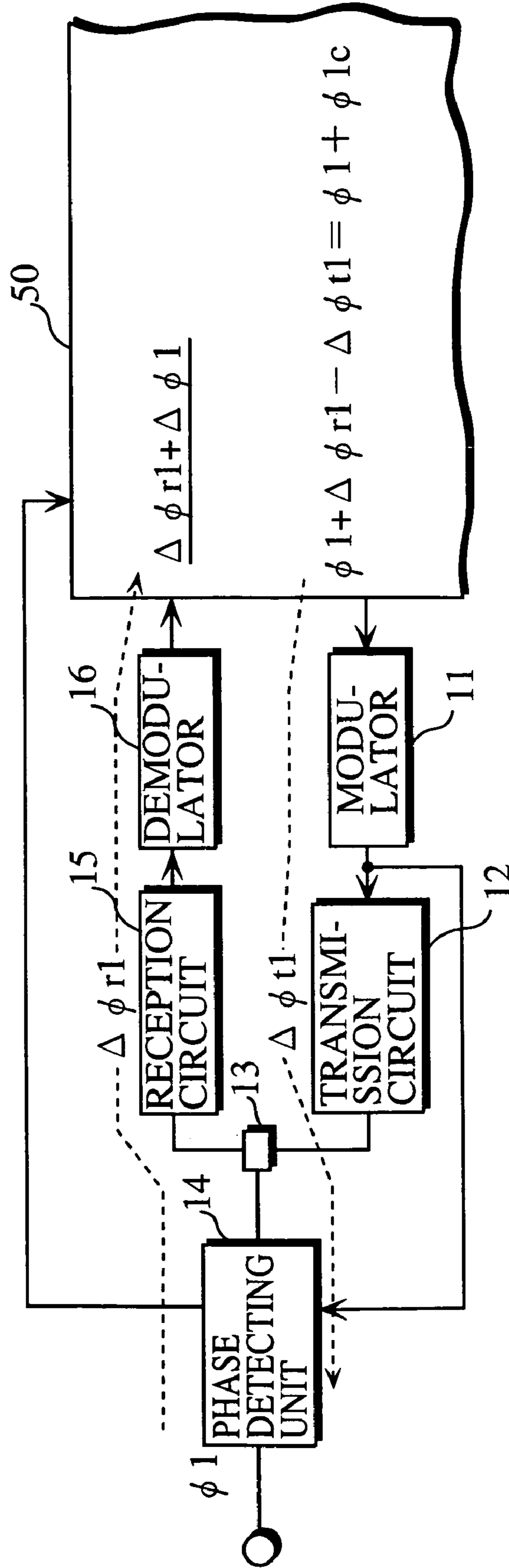
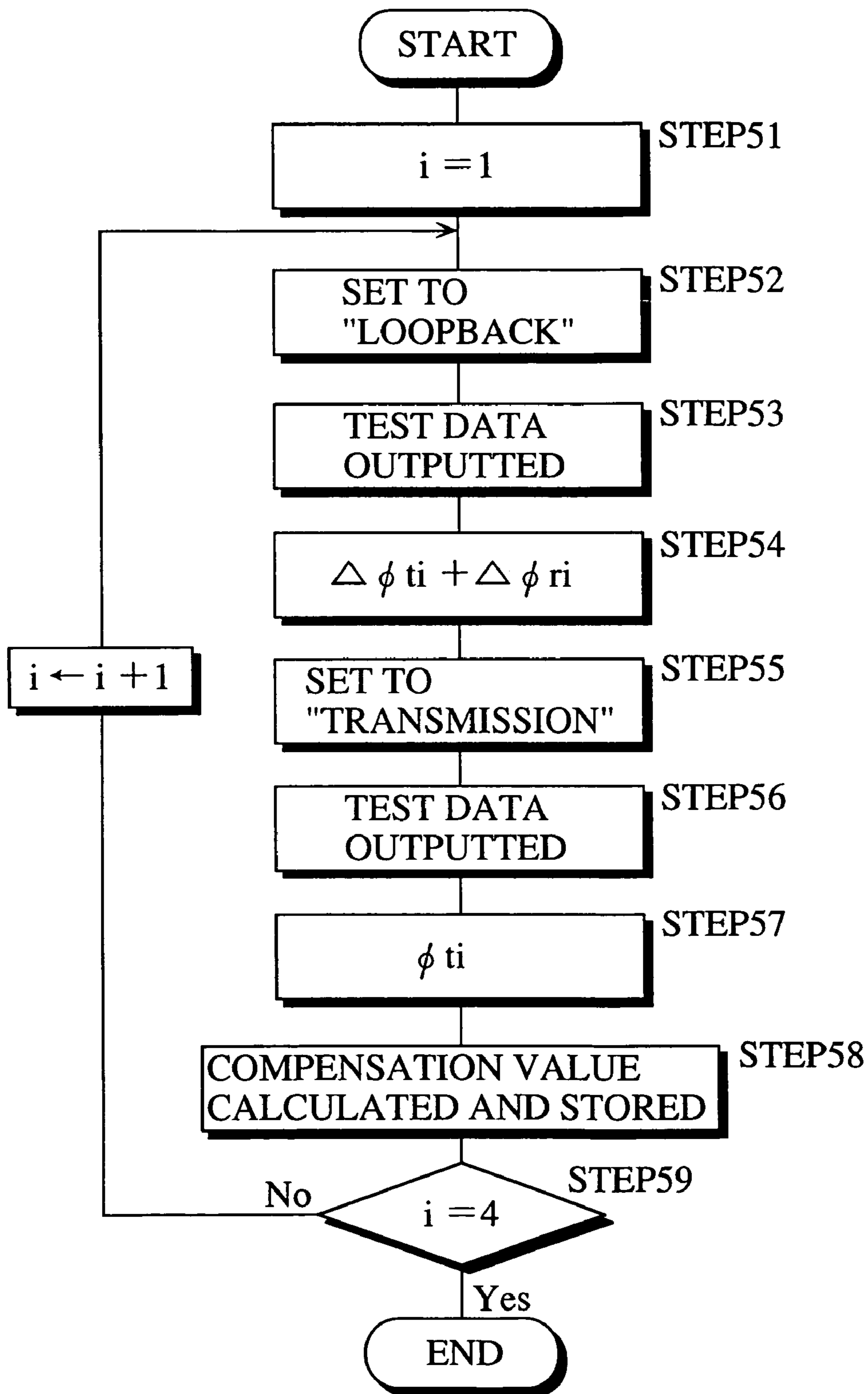

FIG. 5



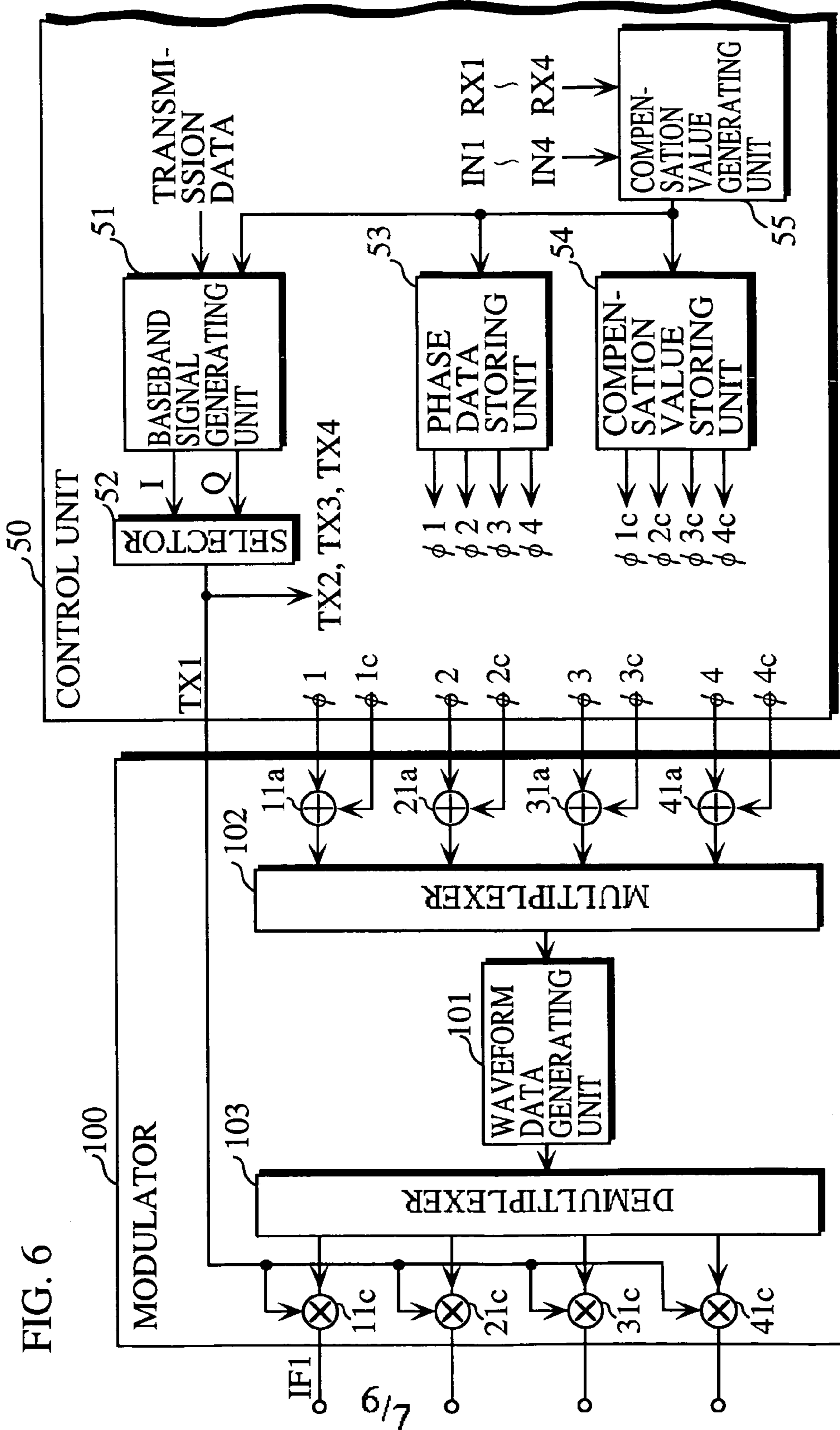
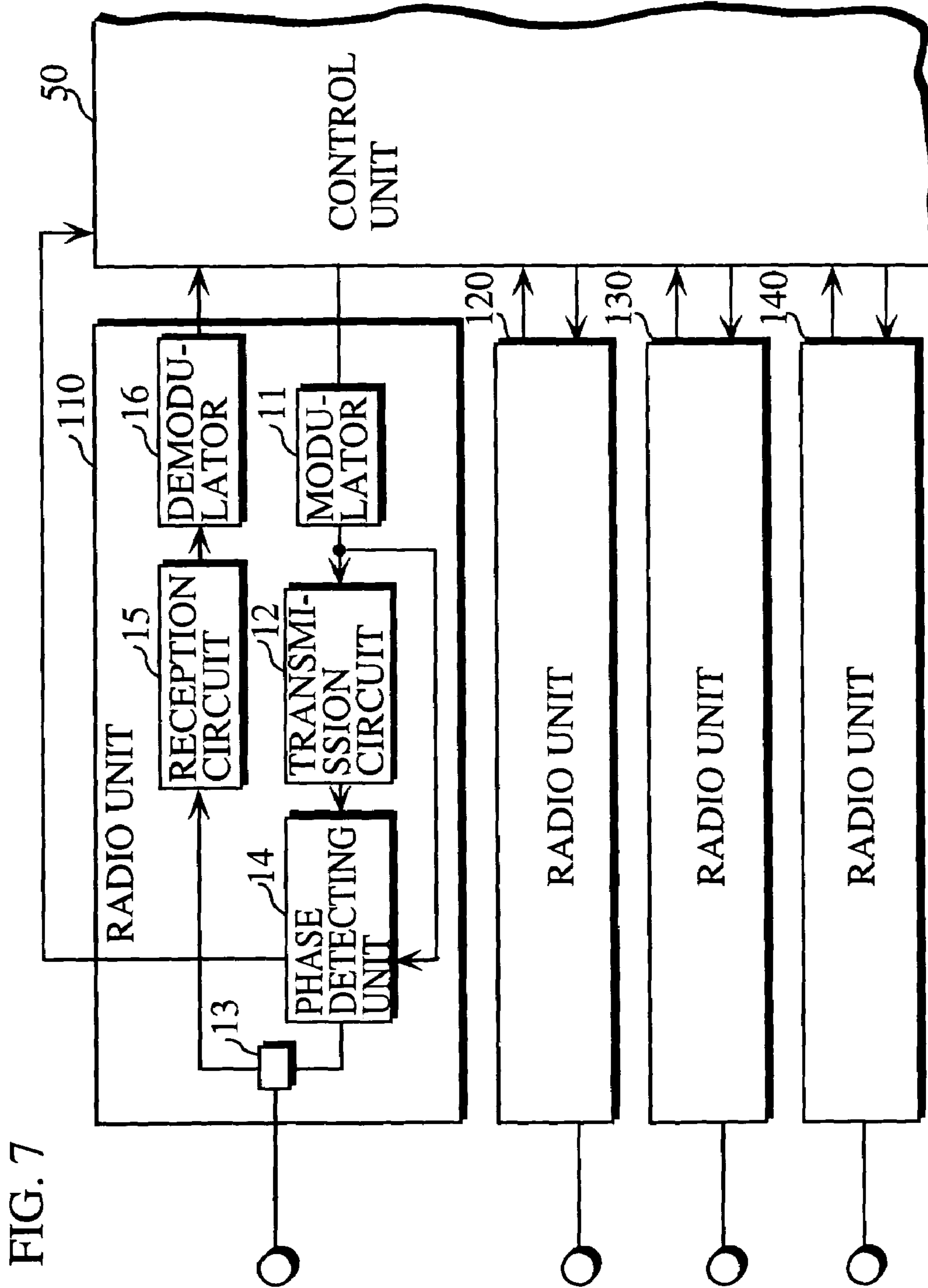

FIG. 6

6/7



1

**ADAPTIVE ARRAY APPARATUS AND
COMPENSATION METHOD FOR
COMPENSATING A PHASE DIFFERENCE
USED FOR GENERATING A DIRECTIVITY
RESPONSE PATTERN**

TECHNICAL FIELD

The present invention relates to an adaptive array apparatus that adaptively generates a directivity pattern for a plurality of antennas and to a compensation method for compensating a phase amount used when generating a directivity pattern.

BACKGROUND ART

To raise transfer efficiency, digital communication devices that transfer information by modulating a carrier wave using a digital information signal (baseband signal) have been developed in recent years.

In digital communication, frequencies can be more efficiently used by raising the transfer speed and converting single frequencies into multichannels for use by several users. Raising the transfer speed, however, leads to deterioration in quality due to fading.

A number of techniques to counteract this problem have been developed. A representative technique is the adaptive array method. This method adaptively generates a directivity pattern using a plurality of antennas and generates an electromagnetic wave so that it only reaches a specified user. First, consider an adaptive array apparatus that has four communication subsystems that each include a transmission circuit, a reception circuit, and an antenna. Separate directivity patterns for transmission and reception can be generated for each communication subsystem by adjusting the gain and phase of each transmission circuit during transmission and by adjusting the gain and phase of each reception circuit during reception. The adaptive array method is described in detail in *Adaptive Signal Processing for Spatial Regions and Its Technical Applications* (in "Transactions of the Institute of Electronics and Communication Engineers of Japan") Vol. J75-B-II No. 11, November 1992.

To perform bidirectional communication using the adaptive array method, it is desirable to have directivity patterns formed by both devices in communication. When this is applied to mobile communication, however, the physical limitations on the size of the mobile devices and the number of antennas used by them make it effectively impossible for mobile devices to form a directivity pattern. Accordingly, the base station forms separate directivity patterns for both transmission and reception. This means that during transmission, the base station forms a directivity pattern that is the same as the ideal directivity pattern that was formed during reception and transmits signals.

The adaptive array method has a problem in that it has been difficult for the base station to form the same directivity pattern during reception and transmission. A directivity pattern is formed by adjusting the gain and phase for each antenna. However, even if transmission is performed with the same phase as was used during reception, differences exist in the propagation characteristics (in particular, phase shift characteristics) of the reception circuit and transmission circuit. These differences have prevented the formation of the same directivity patterns for reception and transmission. The differences in propagation characteristics between the transmission circuit and reception circuit are due to the differences in circuit construction. These differences would

2

still be present even if the same circuit construction were used, due to inconsistencies in the circuit components. This is to say, inconsistencies in the characteristics of actual circuit components lead to inconsistencies in radio circuits that are formed using such components.

DISCLOSURE OF INVENTION

In view of the stated problems, it is a primary object of the present invention to provide an adaptive array apparatus that facilitates the matching of a directivity pattern during transmission with a directivity pattern during reception.

The object of the present invention can be achieved by an adaptive array apparatus that includes a plurality of radio units that each have a transmitting unit, a receiving unit, and an antenna, the adaptive array apparatus including: a storing unit for storing a separate compensation value for each radio unit, each compensation value reflecting phase propagation characteristics of the receiving unit and the transmitting unit in the corresponding radio unit; and a compensating unit for compensating, for each radio unit, a phase amount used when generating a directivity pattern for an output signal by adding the compensation value corresponding to the radio unit to the phase amount.

With the stated construction, compensation values reflecting the phase propagation characteristics of the transmitting unit and receiving unit in each radio unit are stored in the storing unit. These phase propagation characteristics are due to the characteristics of the various circuit components in the transmitting unit and receiving unit. The compensating unit adds a compensation value corresponding to a radio unit to a phase amount used by the transmitting unit in the radio unit to generate a directivity pattern. As a result, the directivity pattern during transmission can easily be matched with the directivity pattern during reception.

Here, the adaptive array apparatus may further include: a generating unit for generating the compensation value for each radio unit in accordance with the phase propagation characteristics of the receiving unit and the transmitting unit in the radio unit, the storing unit storing the compensation values generated by the generating unit.

The generating unit may include: a generating subunit for generating test signals; a first detecting unit for detecting, when a test signal passes the transmitting unit in a radio unit, a first phase shift value for the radio unit; a second detecting unit for detecting, when the test signal passes the transmitting unit and the receiving unit in order in the radio unit, a second phase shift value for the radio unit; and a calculating unit for calculating a phase shift difference between the receiving unit and the transmitting unit in a radio unit using the first phase shift value and the second phase shift value of the radio unit, and for setting the calculated phase shift difference as the compensation value for the radio unit.

With the stated construction, compensation values can be generated with a simple construction that has a generating subunit, a first detecting unit, a second detecting unit, and a calculating unit.

Here, the calculating unit may calculate the compensation values by performing a subtraction using the second phase shift value and a value that is double the first phase shift value.

Also, the generating unit may generate the compensation values at a predetermined interval.

With the stated construction, the generating unit can generate the compensation values at a predetermined interval. This means that if the characteristics of each radio unit of the adaptive array apparatus change over time, the gen-

erating unit will be able to generate a new compensation value for the radio unit(s) whose characteristics have changed.

The stated object of the present invention can also be achieved by a compensation method for use in an adaptive array apparatus that includes a plurality of radio units that each have a transmitting unit, a receiving unit, and an antenna, the compensation method compensating a phase amount that is used when generating a directivity pattern, the compensation method comprising:

a generating step for generating a separate compensation value for each radio unit, each compensation value reflecting phase propagation characteristics of the receiving unit and the transmitting unit in the corresponding radio unit; and

a compensating step for compensating, for each radio unit, a phase amount used when generating a directivity pattern used for an output signal by adding the compensation value generated for the radio unit in the generating step to the phase amount.

This construction can achieve the same effects as those described above.

BRIEF DESCRIPTION OF DRAWINGS

These and other objects, advantages and features of the invention will become apparent from the following description thereof taken in conjunction with the accompanying drawings which illustrate a specific embodiment of the invention. In the drawings:

FIG. 1 is a block diagram showing the construction of an adaptive array apparatus that is an embodiment of the present invention;

FIG. 2 is a block diagram showing the detailed construction of the components of the control unit 50 and the modulators 11, 21, 31, and 41;

FIG. 3 shows the process that generates a compensation value;

FIG. 4 shows the operation during transmission and reception;

FIG. 5 is a flowchart showing the details of the processing by the compensation value generating unit 55 when generating a compensation value;

FIG. 6 is a block diagram showing an alternative construction for the components of the control unit 50 and the modulators 11, 21, 31, and 41; and

FIG. 7 is a block diagram showing the construction of an adaptive array apparatus in a different embodiment of the present invention.

BEST MODE FOR CARRYING OUT THE INVENTION

FIG. 1 is a block diagram showing an adaptive array apparatus that is an embodiment of the present invention. This adaptive array apparatus includes the radio units 10, 20, 30, and 40, the antennas 17, 27, 37, and 47, and the control unit 50. This adaptive array apparatus is provided as a base station for mobile communication using devices such as digital portable telephones. The radio unit 10 includes the modulator 11, the transmission circuit 12, the switch 13, and the phase detecting unit 14.

In the radio unit 10, the modulator 11 modulates a baseband signal (symbol data) that is inputted from the control unit 50 to convert it into an intermediate frequency signal (hereinafter abbreviated to "IF signal"). When doing so, the modulator 11 adds phase data and a compensation value that it receives from the control unit 50 and uses the

result to generate the IF signal. This phase data is a phase amount that enables the generation of a same directivity pattern during transmission as during reception. The compensation value compensates for the phase shift in the transmission output due to the differences in characteristics between the transmission circuit 12 and the reception circuit 15. Examples of digital modulation methods that may be used by the modulator 11 are GMSK (Gaussian-filtered Minimum Shift Keying) and $\pi/4$ shift QPSK (Quadrature Phase Shift Keying).

The transmission circuit 12 converts the IF signal received from the modulator 11 into a high-frequency signal (hereinafter abbreviated to "RF signal"), and amplifies the RF signal to the transmission output level.

The switch 13 switches between (1) a connection (hereinafter called the "transmission connection") that joins the transmission circuit 12 and the phase detecting unit 14 during transmission, (2) a connection (hereinafter called the "reception connection") that joins the phase detecting unit 14 and the reception circuit 15 during reception, and (3) a connection (hereinafter called the "loopback connection") that joins the transmission circuit 12 and the reception circuit 15 when generating a compensation value.

The phase detecting unit 14 operates as follows. When the modulator 11 has directly inputted an IF signal with a specific phase (this signal being the test signal), the phase detecting unit 14 detects the phase difference between the test signal directly inputted by the modulator 11 and the test signal that has been inputted via the transmission circuit 12. In this way, the phase detecting unit 14 detects a phase shift amount as the propagation characteristics of the transmission circuit 12. The phase detecting unit 14 also allows RF signals to pass as they are between the switch 13 and the antenna 17 during transmission and reception.

When detecting the phase difference, the phase detecting unit 14 converts the test signal inputted via the transmission circuit 12 into an IF signal using a frequency dividing circuit (not illustrated). The phase detecting unit 14 then compares this converted test signal with the test signal that has been directly inputted from the modulator 11 to detect the phase difference. As should be understood, the phase shift characteristics of this frequency dividing circuit are assumed to be sufficiently small as to have no effect on the formation of the directivity pattern.

The reception circuit 15 converts the input signal into an IF signal.

The demodulator 16 demodulates the IF signal received from the reception circuit 15 into a baseband signal.

The radio units 20, 30, and 40 all have the same construction as the radio unit 10 and so will not be described.

The control unit 50 performs control over transmission and reception by the radio units 10, 20, 30, and 40. The control unit 50 also controls the gain and phase of each radio unit so as to realize an adaptive array. In particular, during transmission the control unit 50 outputs a compensation value to each radio unit to compensate for the phase shift in the transmission output due to the differences in characteristics between the transmission circuit and the reception circuit in each radio unit. The control unit 50 also generates a compensation value for each radio unit before transmission.

FIG. 2 is a block diagram showing the detailed construction of the components of the control unit 50 and the modulators 11, 21, 31, and 41.

As shown in FIG. 2, the modulator 11 includes the adder 11a, the waveform data generating unit 11b, and the multiplier 11c.

5

The adder **11a** adds the phase data $\phi 1$ and the compensation value $\phi 1c$ received from the control unit **50**. The waveform data generating unit **11b** generates sinewave data whose phase matches the addition result of the adder **11a**. The multiplier **11c** multiplies the sinewave data received from the waveform data generating unit **11b** by the transmission data TX1 received from the control unit **50** to generate an IF signal.

As shown in FIG. 2, the control unit **50** includes a baseband signal generating unit **51**, a selector **52**, a phase data storing unit **53**, a compensation value storing unit **54**, and a compensation value generating unit **55**. Although shown in FIG. 2 as being functionally divided into components, the control unit **50** is in fact composed of a DSP (Digital Signal Processor).

The baseband signal generating unit **51** generates a baseband signal (symbol data) by converting transmission data that is serially inputted into I (in-phase) and Q (quadrature) components. The selector **52** outputs transmission data TX1~TX4 produced by multiplexing the I component and Q component of the baseband signal.

The phase data storing unit **53** stores the phase data $\phi 1\sim\phi 4$ as phase amounts that are used by the control unit **50** when operating as an adaptive array apparatus to generate a directivity pattern during transmission that is the same as the directivity pattern during reception. Such phase data is explained in detail in *Adaptive Signal Processing for Spatial Regions and Its Technical Applications* (in "Transactions of the Institute of Electronics and Communication Engineers of Japan") Vol. J75-B-II No. 11 November, 1992, and so will not be described here.

The compensation value storing unit **54** stores compensation values $\phi 1c\sim\phi 4c$ as phase amounts for correcting phase shift in the transmission output due to the differences in characteristics between the transmission circuit and the reception circuit in each radio unit.

The compensation value generating unit **55** performs a compensation value generation process that generates the compensation values $\phi 1c\sim\phi 4c$ and has the resulting values stored in the compensation value storing unit **54**. The compensation value generating unit **55** performs this compensation value generation process at predetermined intervals. This predetermined interval is preferably several days or several weeks, and should be determined in accordance with the extent to which the phase shift characteristics of the reception circuit **15** and the transmission circuit **12** change over time and the permitted difference in phase shift characteristics

As shown in FIG. 4, when an electromagnetic wave is received from another radio device during reception, the received signal RX1 is subject to phase shift of $\Delta\phi r1$ ($=0.5^\circ$) due to the reception circuit **15**.

During transmission, however, transmission data TX1 is compensated by the addition of the compensation value $\phi 1c$ ($=\Delta\phi r1-\Delta\phi t1=0.2^\circ$) and the phase data $\phi 1$. This transmission data TX1 is transmitted from the antenna via the transmission circuit **12**, and so is subject to phase shift of $\Delta\phi t1+\phi 1c=0.2+0.3=0.5^\circ$.

In this way the phase shift that occurs inside a radio unit during transmission becomes 0.5° which is equal to the phase shift during reception. This means that the addition of the compensation value makes the phase characteristics of the reception and transmission systems equal.

During reception and transmission, the radio units **20**, **30**, and **40** all operate in the same way as the radio unit **10**, so that no further explanation will be given.

6

FIG. 6 is a block diagram showing an alternative construction for the components of the control unit **50** and the modulators **11**, **21**, **31**, and **41**

FIG. 6 shows a construction where the modulator **100** is used in place of the modulators **11**, **21**, **31**, and **41** of FIG. 2. Here, a single waveform data generating unit compensation value generation process generates the compensation values $\phi 1c$, $\phi 2c$, $\phi 3c$, and $\phi 4c$ corresponding to the four radio units and stores the values in the compensation value storing unit **54**, as shown by the representation in FIG. 3 and the flowchart in FIG. 5.

The following is a description of how the stored compensation values are used during standard transmission and reception.

In order to generate a directivity pattern, the present adaptive array apparatus adjusts the gain and phase of each radio unit. The adaptive array apparatus adjusts gain according to conventional methods that will not be described.

The present adaptive array apparatus performs phase adjustment by supplying each radio unit with respective phase data $\phi 1\sim\phi 4$ for the generation of a directivity pattern, by having each radio unit add a respective compensation value $\phi 1c\sim\phi 4c$ to this phase data, and by having each radio unit use the result of this addition when transmitting.

FIG. 4 shows the operation of the radio unit **10** during transmission and reception. In this example, the phase shift amount $\Delta\phi r1$ of the reception circuit **15** is 0.5° while the phase shift amount $\Delta\phi t1$ of the transmission circuit **12** is 0.3° . For ease of explanation, the phase data $\phi 1$ in this example is 0° . value generating unit **55** sets this difference as the compensation value $\phi 1c$, and has it stored in the compensation value storing unit **54** (Step **58**). Note that the compensation value generating unit **55** calculates this compensation value $\phi 1c$ ($=\Delta\phi r1-\Delta\phi t1$) by performing the calculation $(\Delta\phi t1+\Delta\phi r1)-2*(\Delta\phi t1)$ using the detected values $(\Delta\phi t1+\Delta\phi r1)$ and $(\Delta\phi t1)$.

The compensation value generating unit **55** calculates the compensation values $\phi 2c$, $\phi 3c$, $\phi 4c$ ($\Delta\phi r2-\Delta\phi t2$, $\Delta\phi r3-\Delta\phi t3$, $\Delta\phi r4-\Delta\phi t4$) in the same way for the radio units **20**, **30**, and **40**, and has these compensation values stored in the compensation value storing unit **54** (Steps **59**, **51**).

The above processing generates a separate compensation value for each radio unit and has the resulting values stored in the compensation value storing unit **54**.

This completes the description of the construction of the adaptive array apparatus in this embodiment. The operation of this adaptive array apparatus is described below.

The present adaptive array apparatus performs a compensation value generation process before performing ordinary transmission or reception. As mentioned earlier, this compensation value generation process is preferably performed at regular intervals. The route (A). These analog components are the transmission circuit **12** and the reception circuit **15**. The compensation value generating unit **55** compares the phase of the test data received via the RX1 terminal with the phase of the original test data, and so detects the phase shift $(\Delta\phi t1+\Delta\phi r1)$ of the route (A) (Step **54**).

The compensation value generating unit **55** then sets the switch **13** into the transmission connection (Step **55**) and retransmits the test data (Step **56**). This test data passes on the paths (B) and (C) in FIG. 3 and reaches the phase detecting unit **14**. Path (C) differs from path (B) in that it also passes through the transmission circuit **12**. This means that the test data on the path (C) is further affected by phase shift due to the transmission circuit **12**. The phase detecting unit **14** compares the phase of the test data received on the path (B) with the phase of the test data received on the path (C),

and so detects the phase shift $\Delta\phi_{t1}$ due to the transmission circuit 12. The compensation value generating unit 55 receives this detection result via the IN1 terminal (Step 57).

Having received these detected values ($\Delta\phi_{t1} + \Delta\phi_{r1}$) and ($\Delta\phi_{t1}$), the compensation value generating unit 55 finds the difference ($\Delta\phi_{r1} - \Delta\phi_{t1}$) in between the phase shift of a reception system and the phase shift of a transmission system in a radio unit. The compensation between these components. As one example, if the permitted range for the difference in phase shift characteristics is $-10\% \sim +10\%$, the predetermined interval will be set so that the compensation value will be updated before the difference in phase shift characteristics between the transmission circuit 12 and the reception circuit 15 exceeds this $-10\% \sim +10\%$ range. This means that the compensation value generating unit 55 updates the compensation values according to changes over time in the radio units.

FIG. 5 is a flowchart showing the details of the processing by the compensation value generating unit 55 when generating a compensation value. This compensation value generation process is explained below using FIG. 3.

The compensation value generating unit 55 first operates for radio unit 10 (Step 51 in FIG. 5). The compensation value generating unit 55 sets the switch 13 in the loopback connection (Step 52), and outputs test data with a specified phase (Step 53). As one example, the compensation value generating unit 55 may output test data where the phase data ϕ_1 , the compensation value ϕ_{1c} , and the transmission data TX1 are all zero.

The outputted test data reaches the RX1 terminal of the control unit 50 via the route shown as (A) in FIG. 3. The phase of the test data will be affected by the components, especially the analog components, on this 101 is shared between the four radio units 10, 20, 30, and 40. The multiplexer 102 and the demultiplexer 103 are also provided to enable this sharing of waveform data generating unit 101.

The waveform data generating unit 101 has a processing speed that is four times faster than each of the waveform data generating units 11b, 21b, 31b, and 41b of FIG. 2. Consequently, the multiplexer 102 multiplexes the four addition results of the four adders 11a, 21a, 31a, and 41a according to time division and outputs the multiplexed addition results to the waveform data generating unit 101. The demultiplexer 103 distributes each waveform generated by the waveform data generating unit 101 to an appropriate multiplier out of the multipliers 11c, 21c, 31c, and 41c.

Quadrupling the processing speed of the modulator 100 in this way enables a reduction in the number of components and consequently a reduction in a dimensions of the circuit.

FIG. 7 is a block diagram showing the construction of an adaptive array apparatus in a different embodiment of the present invention. This adaptive array apparatus only differs from the construction in FIG. 1 by including the radio units 110, 120, 130, and 140 in place of the radio units 10, 20, 30, and 40. The following explanation will focus on this difference.

The radio unit 110 only differs from the radio unit 10 in having the phase detecting unit 14 provided between the transmission circuit 12 and the switch 13. That aside, all functions of the radio unit 110 are the same as those of the radio unit 10.

The radio units 120, 130, and 140 are the same as the radio unit 110, and so will not be explained.

The repositioning of the phase detecting unit 14 in this embodiment facilitates the installation of the phase detecting unit 14. Note that the phase detecting unit 14 may instead be provided between the switch 13 and the reception circuit 15.

The compensation value generation process in this embodiment should preferably be performed regularly, with the interval between executions being determined according to the extent to which the characteristics of the circuit elements change over time. When circuit components whose characteristics hardly change are used, a compensation value for each radio unit may be written into the compensation value storing unit 54 at the factory before shipment. In this case, the compensation value generating unit 55 and phase detecting unit 14 in FIG. 2 become unnecessary.

INDUSTRIAL APPLICABILITY

The adaptive array apparatus of the present invention corrects phase during transmission according to a difference in phase shift between the transmission circuit and the reception circuit. Even when there is a large difference in characteristics between the transmission circuit and the reception circuit, the directivity pattern for transmission can be made the same as the directivity pattern for reception. This is especially effective when low-cost components are used in the transmission circuit and reception circuit of a base station used in mobile communication, since such the difference in characteristics between such components would otherwise be problematic.

The invention claimed is:

1. An adaptive array apparatus that includes a plurality of radio units that each has a transmitting unit, a receiving unit, and an antenna,

the adaptive array apparatus comprising:

storing means for storing a separate compensation value for each radio unit, each compensation value reflecting phase propagation characteristics of the receiving unit and the transmitting unit in the corresponding radio unit;

compensating means for compensating, for each radio unit, a phase amount used when generating a directivity pattern for an output signal by adding the compensation value corresponding to the radio unit to the phase amount; and

generating means for generating the compensation value for each radio unit in accordance with the phase propagation characteristics of the receiving unit and the transmitting unit in the radio unit, wherein the generating means includes:

a generating unit for generating test signals;

a first detecting unit for detecting, when a test signal passes the transmitting unit in a radio unit, a first phase shift value for the radio unit;

a second detecting unit for detecting, when the test signal passes the transmitting unit and the receiving unit in order in the radio unit, a second phase shift value for the radio unit; and

a calculating unit for calculating a phase shift difference between the receiving unit and the transmitting unit in a radio unit using the first phase shift value and the second phase shift value of the radio unit, and for setting the calculated phase shift difference as the compensation value for the radio unit.

2. The adaptive array apparatus of claim 1, wherein the calculating unit calculates the compensation values by performing a subtraction using the second phase shift value and a value that is double the first phase shift value.

3. The adaptive array apparatus of claim 2, wherein the generating means generates the compensation values at a predetermined interval.

9

4. The adaptive array apparatus of claim 3,
wherein the predetermined interval used by the generating
means is a period that is determined according to
- (1) a degree to which a difference in phase shift amounts
between the transmitting unit and the receiving unit of
a radio unit changes over time, and
 - (2) a permitting range for the difference in phase shift
amounts.
5. The adaptive array apparatus of claim 1,
wherein the generating means generates the compensation
values at a predetermined interval.
6. The adaptive array apparatus of claim 5,
wherein the predetermined interval used by the generating
means is a period that is determined according to
- (1) a degree to which a difference in phase shift amounts
between the transmitting unit and the receiving unit of
a radio unit changes over time, and
 - (2) a permitting range for the difference in phase shift
amounts.
7. A compensation method for use in an adaptive array
apparatus that includes a plurality of radio units that each has
a transmitting unit, a receiving unit, and an antenna, the
compensation method compensating a phase amount that is
used when generating a directivity pattern,
the compensation method comprising:
- a generating step for generating a separate compensa-
tion value for each unit, each compensation value
reflecting phase propagation characteristics of the
receiving unit and the transmitting unit in the corre-
sponding radio unit, and
 - a compensating step for compensating, for each radio
unit, a phase amount used when generating a direc-

10

- tivity pattern used for an output signal by adding the
compensation value generated for the radio unit in
the generating step to the phase amounts,
wherein the generating step includes:
- an outputting step for outputting test signals;
 - a first detecting step for detecting, when a test signal
passes the transmitting unit in a radio unit, a first
phase shift value for the radio unit;
 - a second detecting step for detecting when the test
signal passes the transmitting unit and the receiv-
ing unit in order in the radio unit, a second phase
shift value for the radio unit; and
 - a calculating step for calculating a phase shift dif-
ference between the receiving unit and the trans-
mitting unit in a radio unit using the first phase
shift value and the second phase shift value of the
radio unit, and for setting the calculating phase
shift difference as the compensation value for the
radio unit.
8. The compensation method of claim 7,
wherein the calculating step calculates the compensation
values by performing a subtraction using the second
phase shift value and a value that is double the first
phase shift value.
9. The compensation method of claim 8,
wherein the generating step generates the compensation
values at a predetermined interval.

* * * * *