

US007096678B2

(12) **United States Patent**
Petroski

(10) **Patent No.:** **US 7,096,678 B2**
(45) **Date of Patent:** **Aug. 29, 2006**

(54) **METHOD AND APPARATUS FOR INCREASING NATURAL CONVECTION EFFICIENCY IN LONG HEAT SINKS**

(75) Inventor: **James T. Petroski**, Parma, OH (US)

(73) Assignee: **GELcore LLC**, Valley View, OH (US)

(*) Notice: Subject to any disclaimer, the term of this patent is extended or adjusted under 35 U.S.C. 154(b) by 0 days.

(21) Appl. No.: **10/931,506**

(22) Filed: **Sep. 1, 2004**

(65) **Prior Publication Data**

US 2006/0042291 A1 Mar. 2, 2006

(51) **Int. Cl.**
F25B 21/02 (2006.01)

(52) **U.S. Cl.** **62/3.2; 62/264; 62/407**

(58) **Field of Classification Search** **62/3.2, 62/3.3, 3.6, 3.7, 264, 407, 428, 440; 165/80.3, 165/185; 361/697, 703, 704**
See application file for complete search history.

(56) **References Cited**

U.S. PATENT DOCUMENTS

4,390,352 A * 6/1983 Grun 96/126
4,494,380 A * 1/1985 Cross 62/3.2

4,646,528 A * 3/1987 Marcade et al. 62/127
4,764,193 A * 8/1988 Clawson 62/3.3
5,433,080 A * 7/1995 Boeckel 62/3.6
5,857,767 A * 1/1999 Hochstein 362/294
6,255,786 B1 * 7/2001 Yen 315/291
6,269,864 B1 * 8/2001 Kabadi 165/80.3
6,371,200 B1 * 4/2002 Eaton 165/80.3
6,390,188 B1 * 5/2002 Chen 165/185
6,472,823 B1 * 10/2002 Yen 315/112
6,799,864 B1 * 10/2004 Bohler et al. 362/236
2002/0109970 A1 * 8/2002 Yang et al. 361/695

FOREIGN PATENT DOCUMENTS

JP 09145246 A * 6/1997

OTHER PUBLICATIONS

International Search Report from PCT/US2005/30732.

* cited by examiner

Primary Examiner—Mohammad M. Ali

(74) *Attorney, Agent, or Firm*—Fay, Sharpe, Fagan, Minnich & McKee, LLP

(57) **ABSTRACT**

An electrical apparatus that is cooled via natural convection includes an electrical component, a vertical heat dissipation surface in thermal communication with the electrical component, and a diverter extending from the heat dissipation surface. The diverter disrupts vertical airflow over the heat dissipation surface.

18 Claims, 4 Drawing Sheets

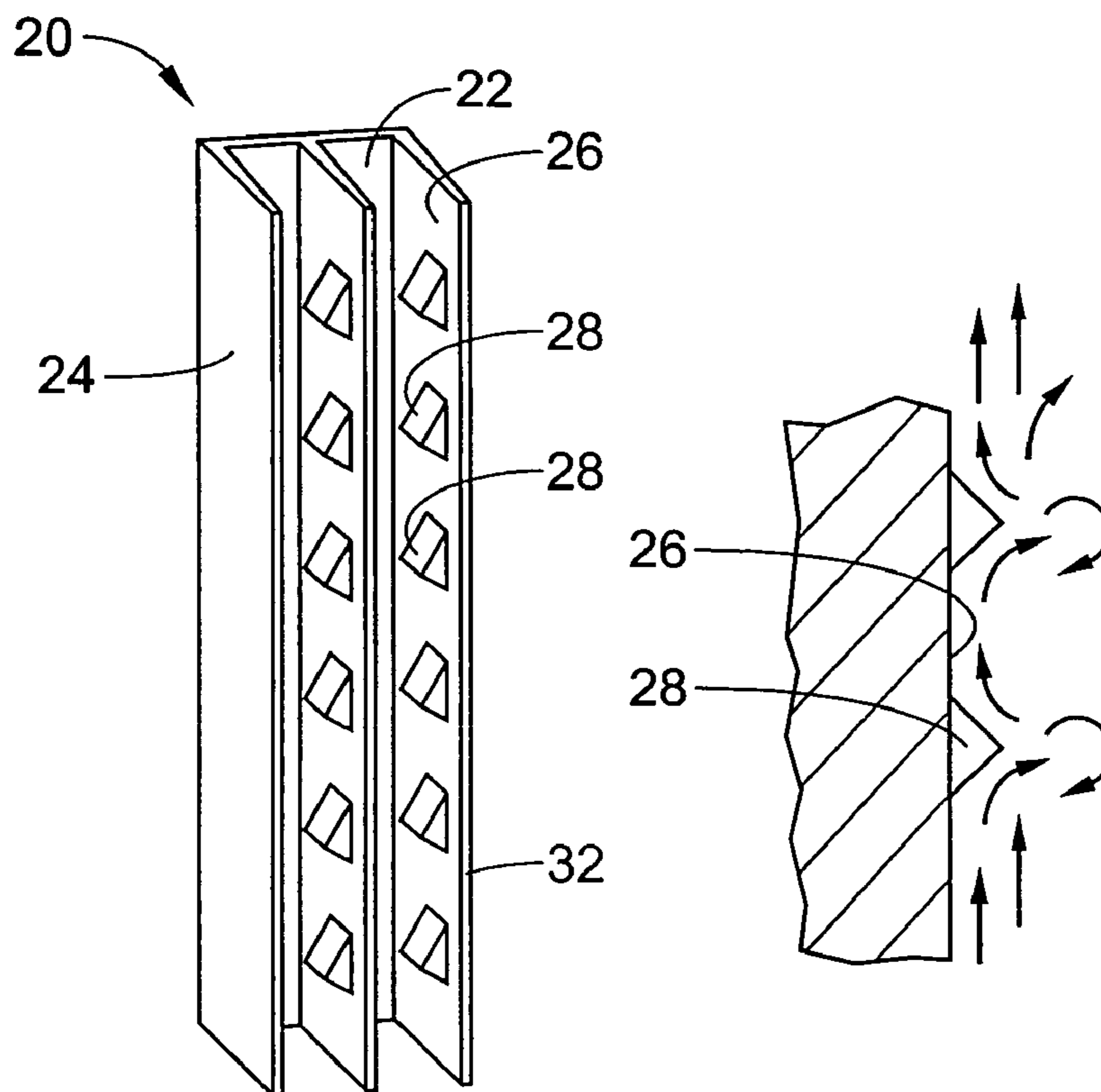

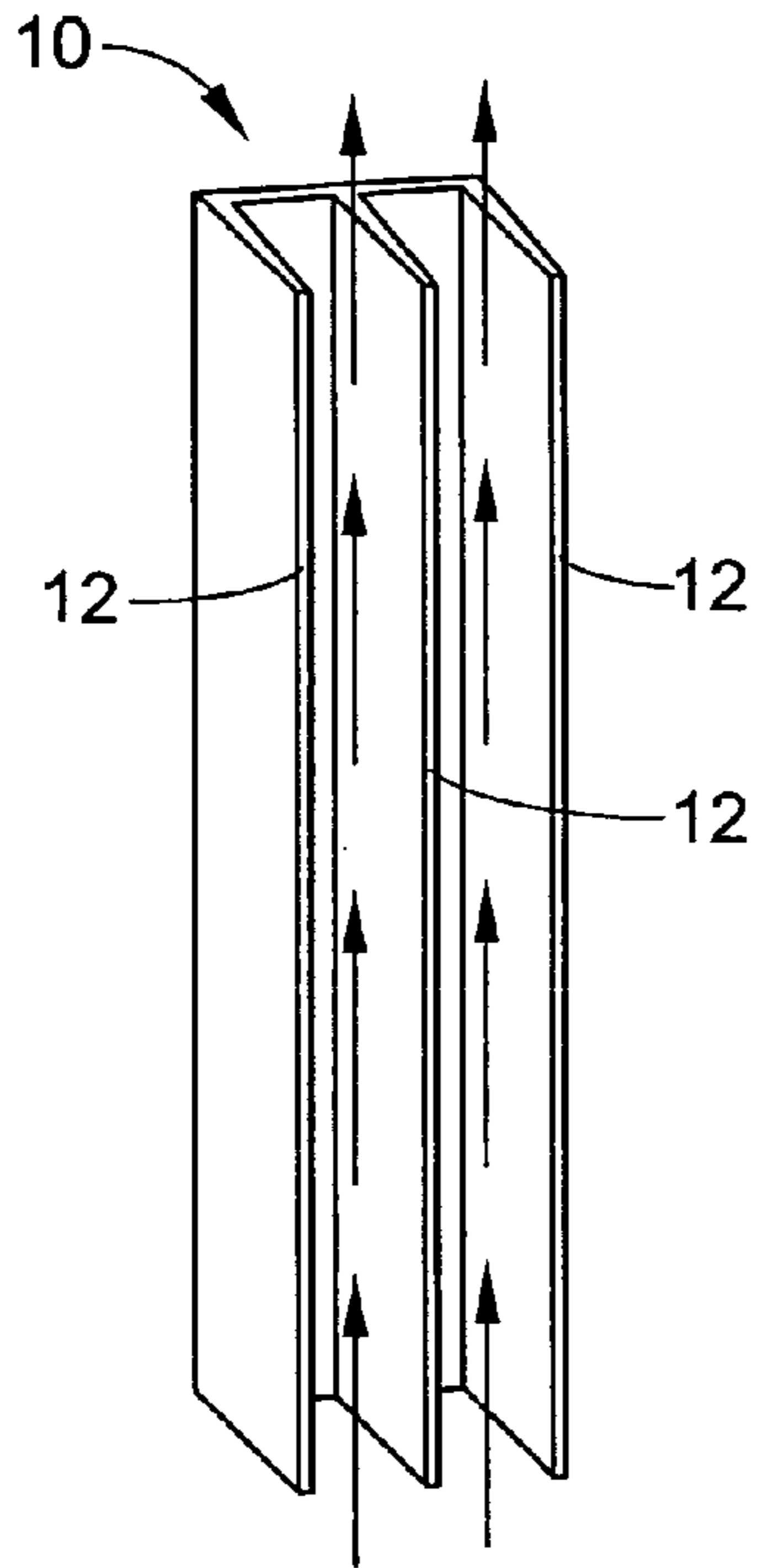

FIG. 1
PRIOR ART

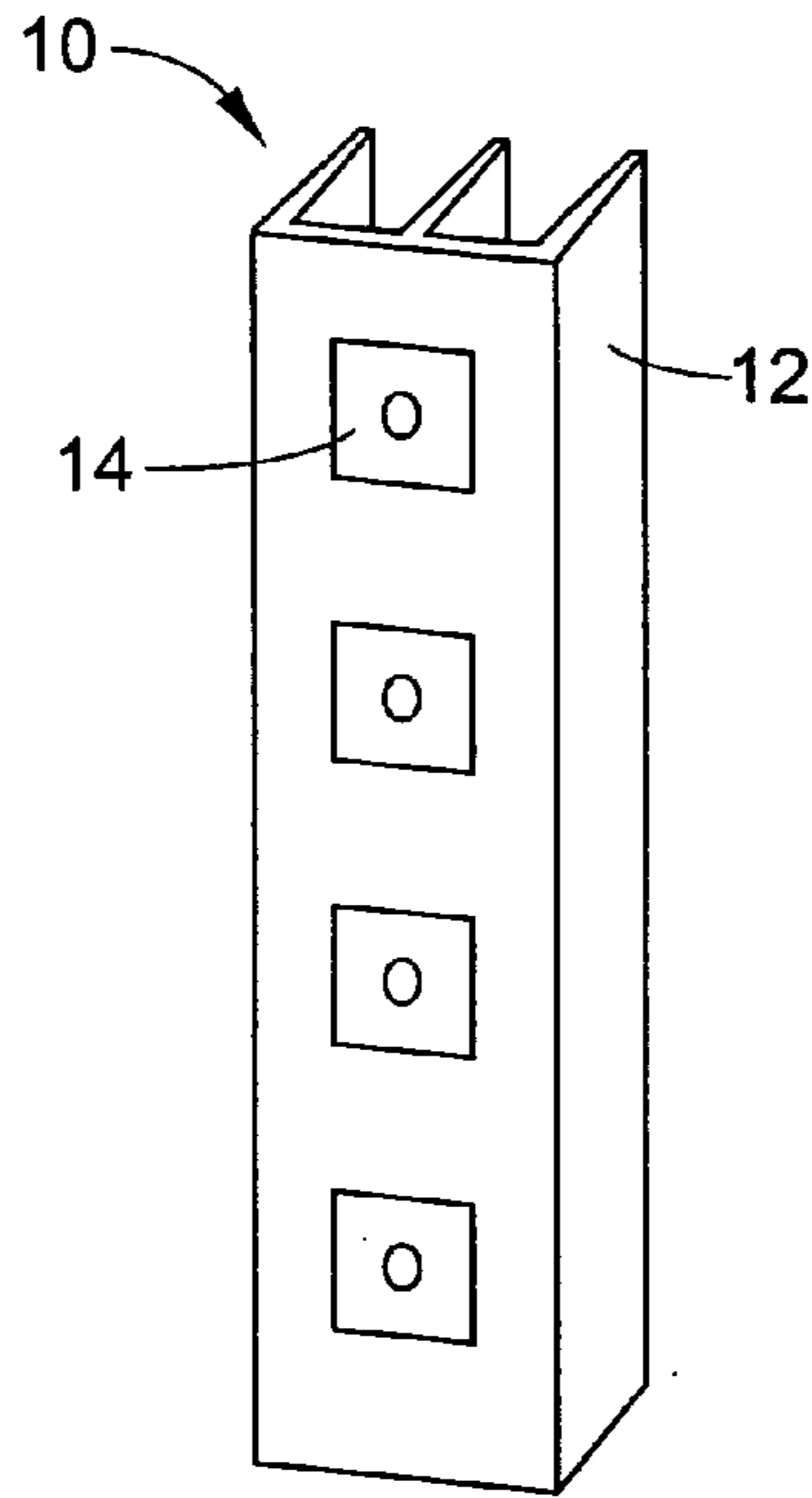

FIG. 2
PRIOR ART

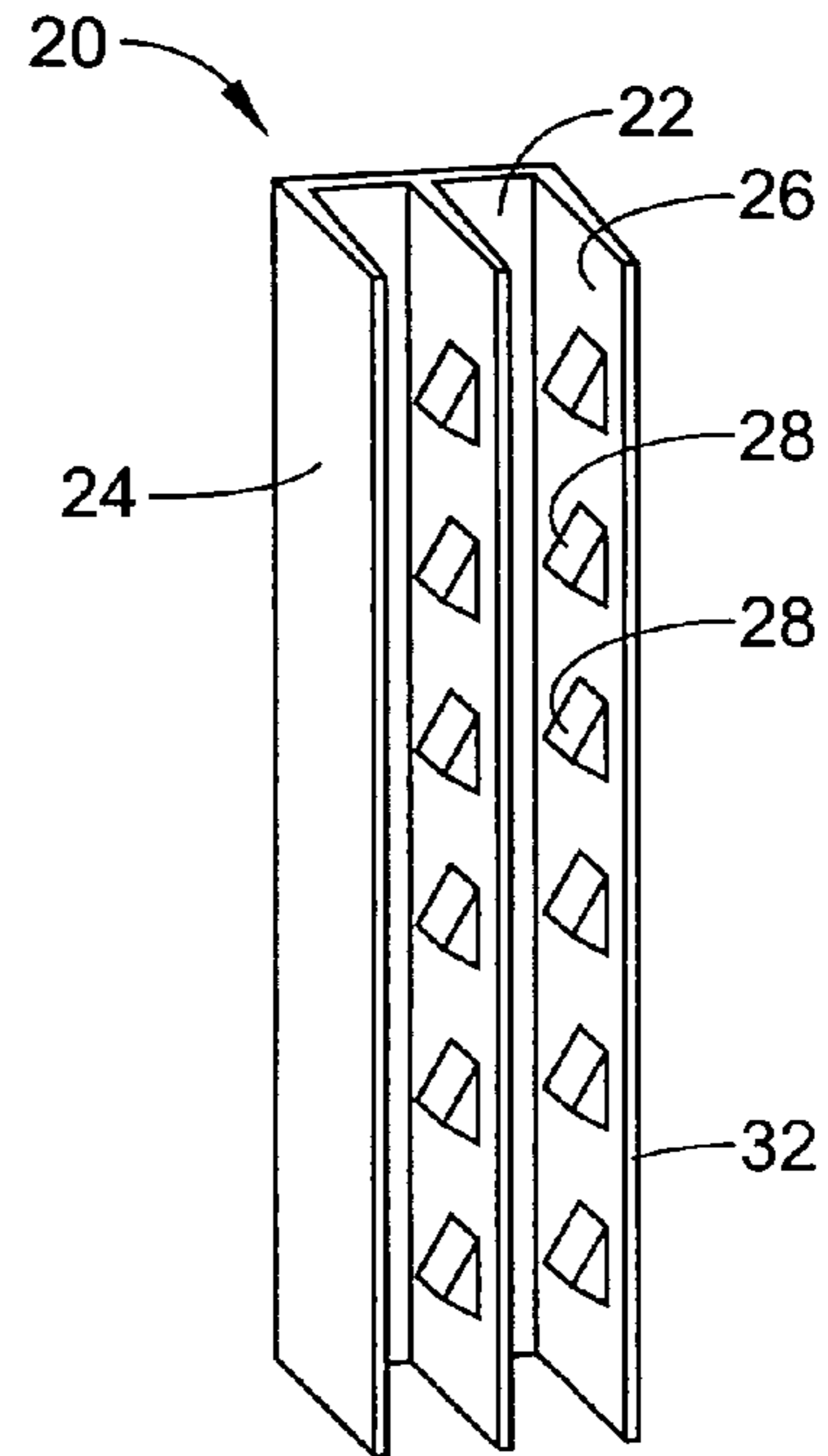

FIG. 4

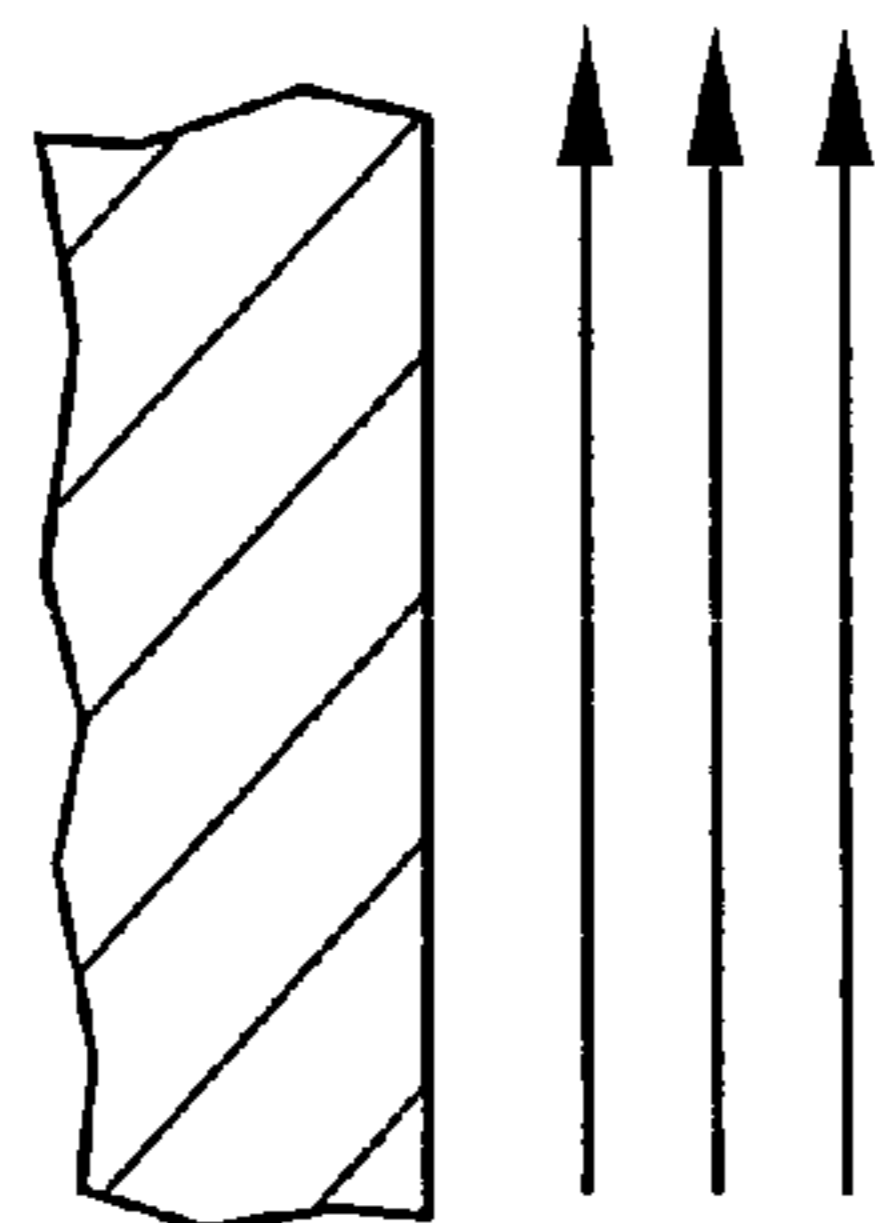

FIG. 3
PRIOR ART

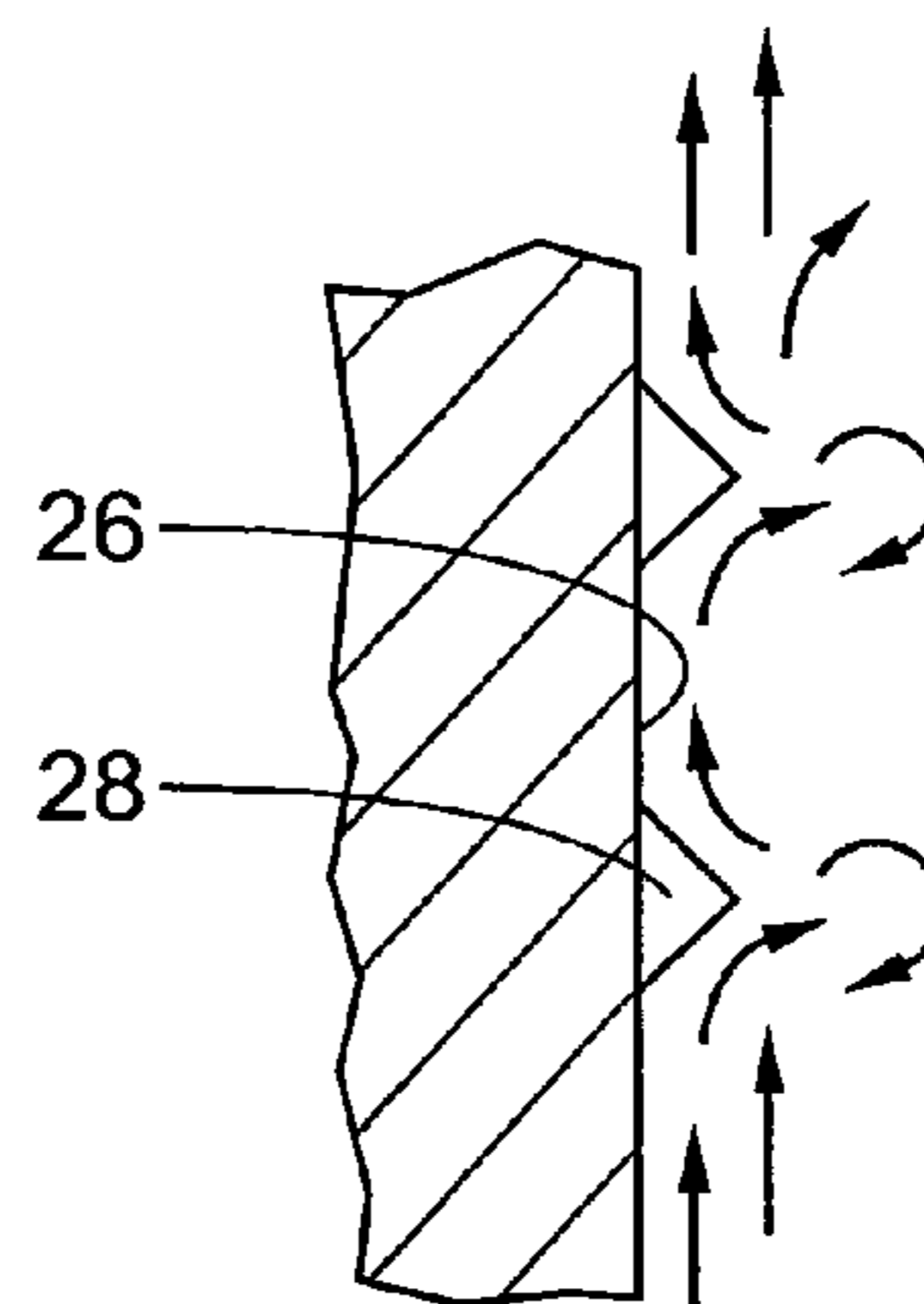

FIG. 5

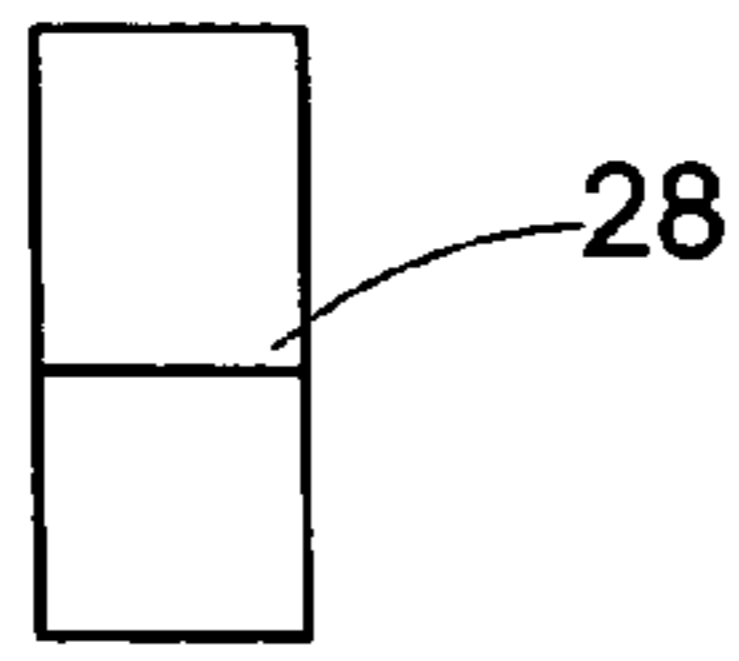

FIG. 6A

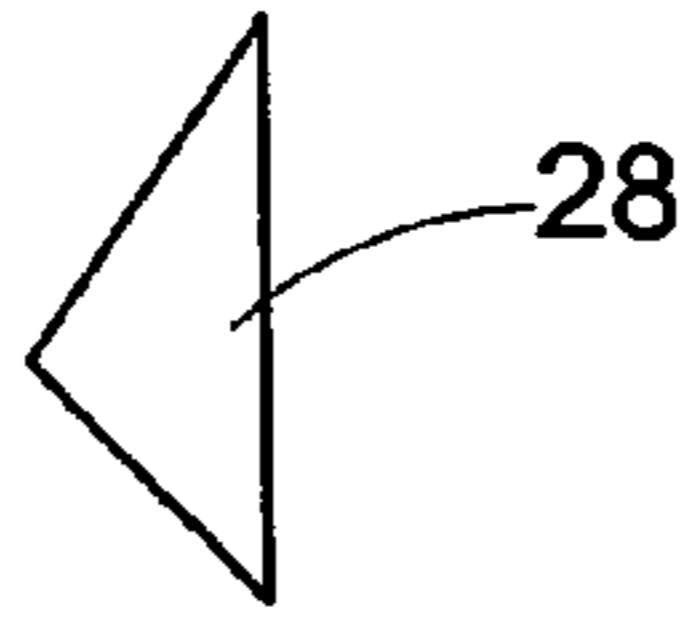

FIG. 6B

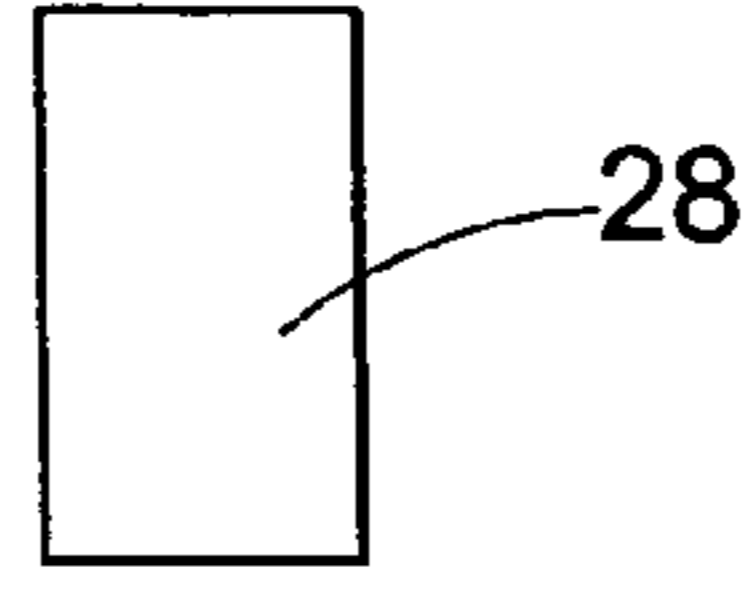

FIG. 6C

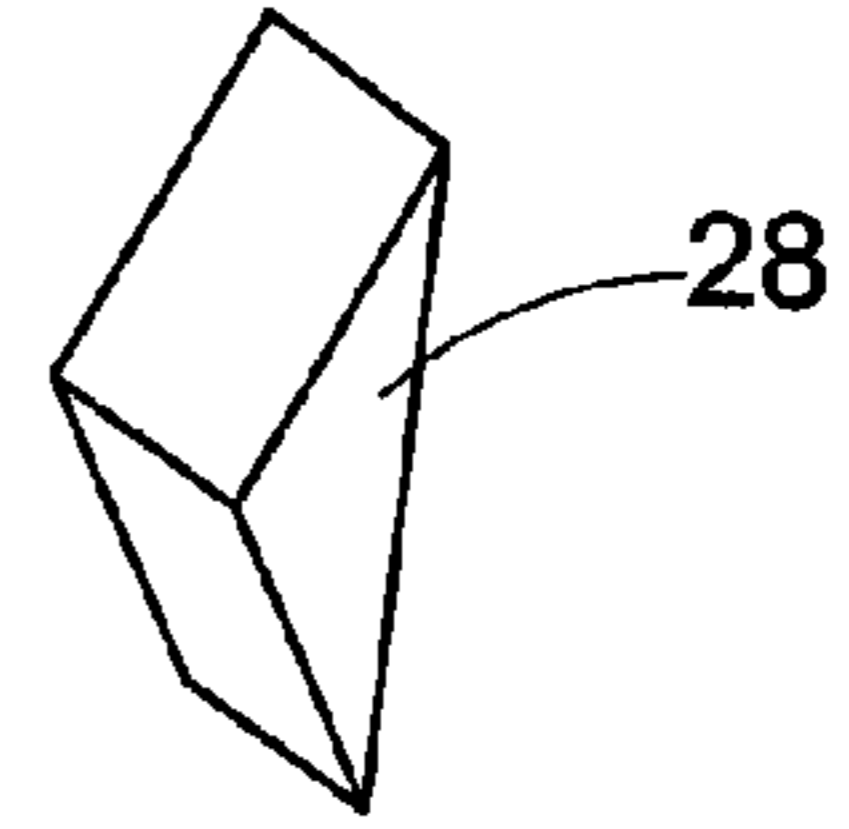

FIG. 6D

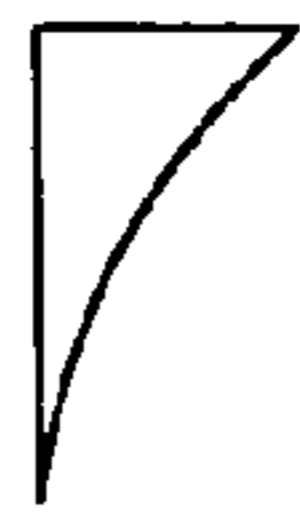

FIG. 7A



FIG. 7B



FIG. 7C

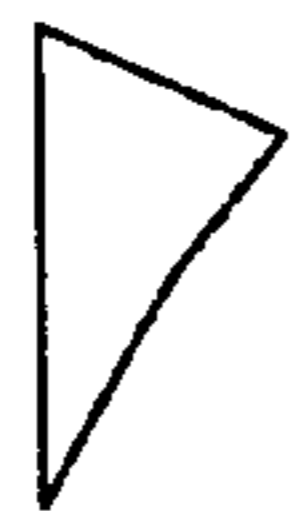

FIG. 7D



FIG. 7E

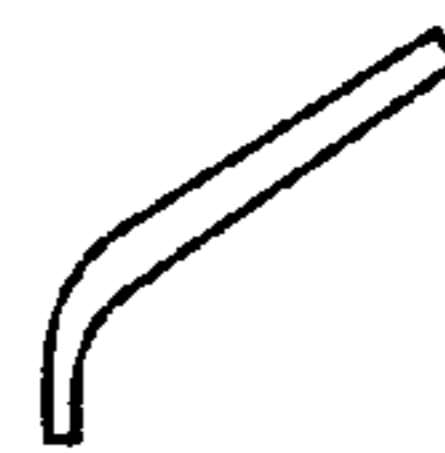
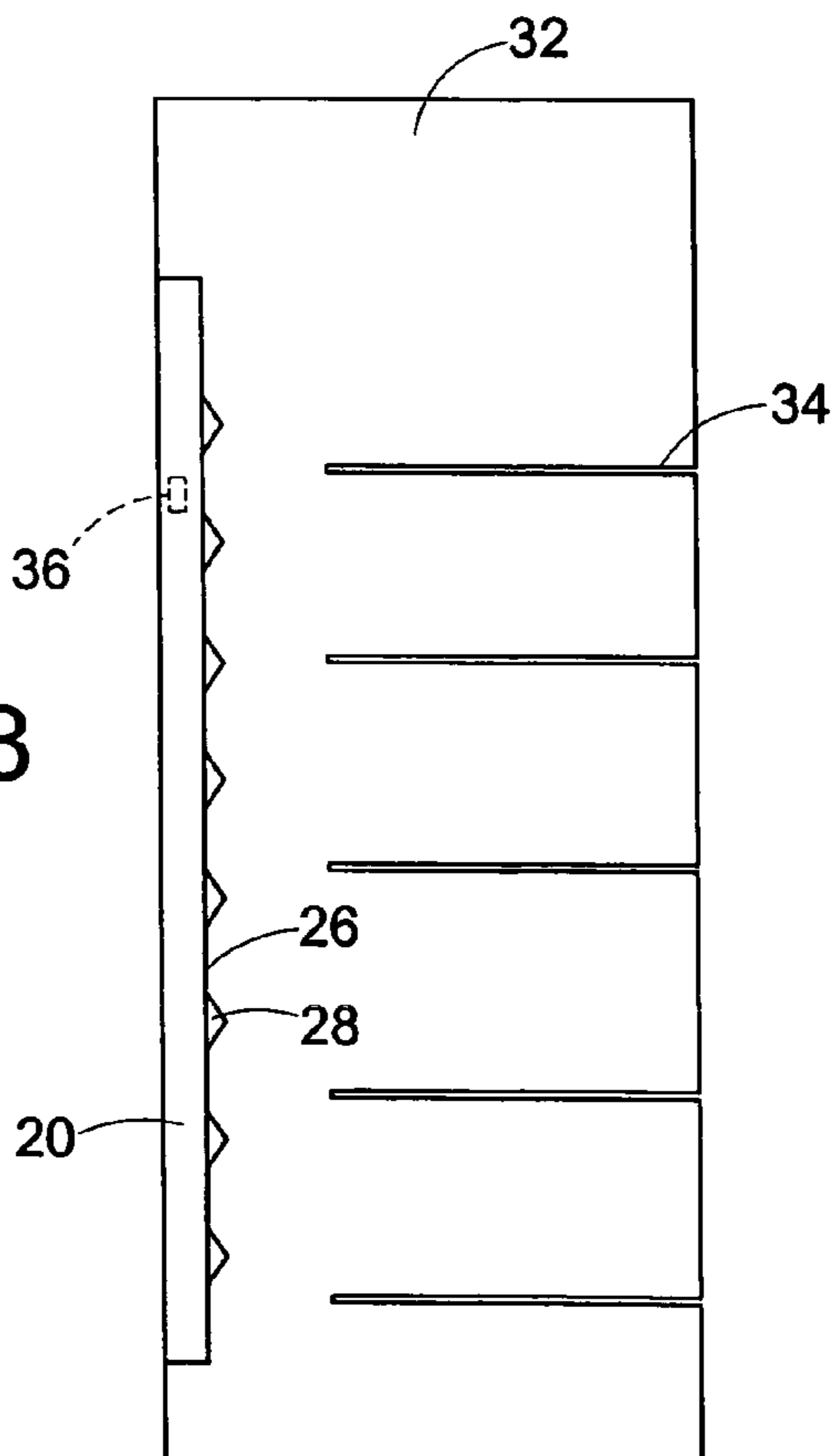

FIG. 7F

FIG. 8



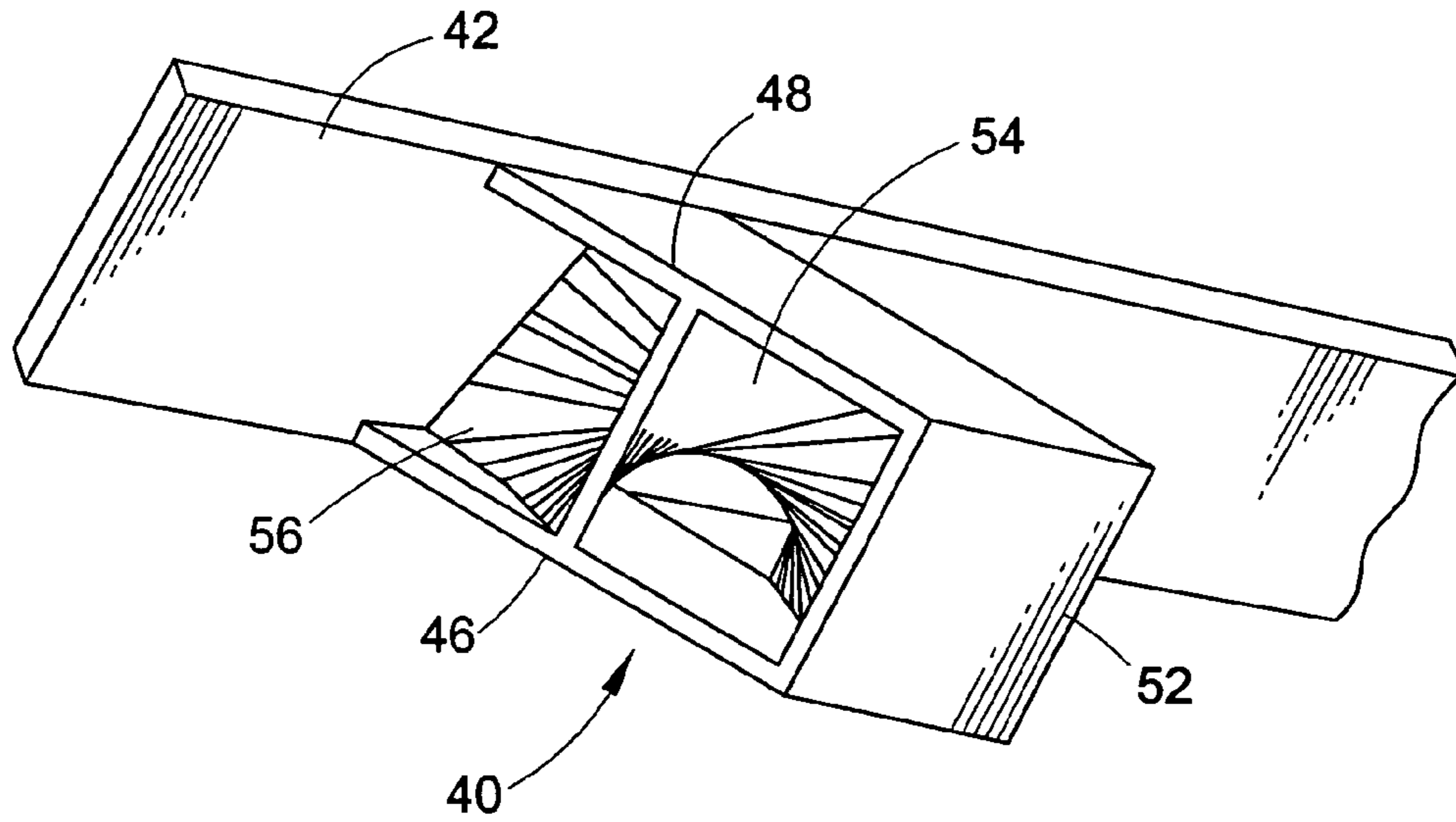

FIG. 9

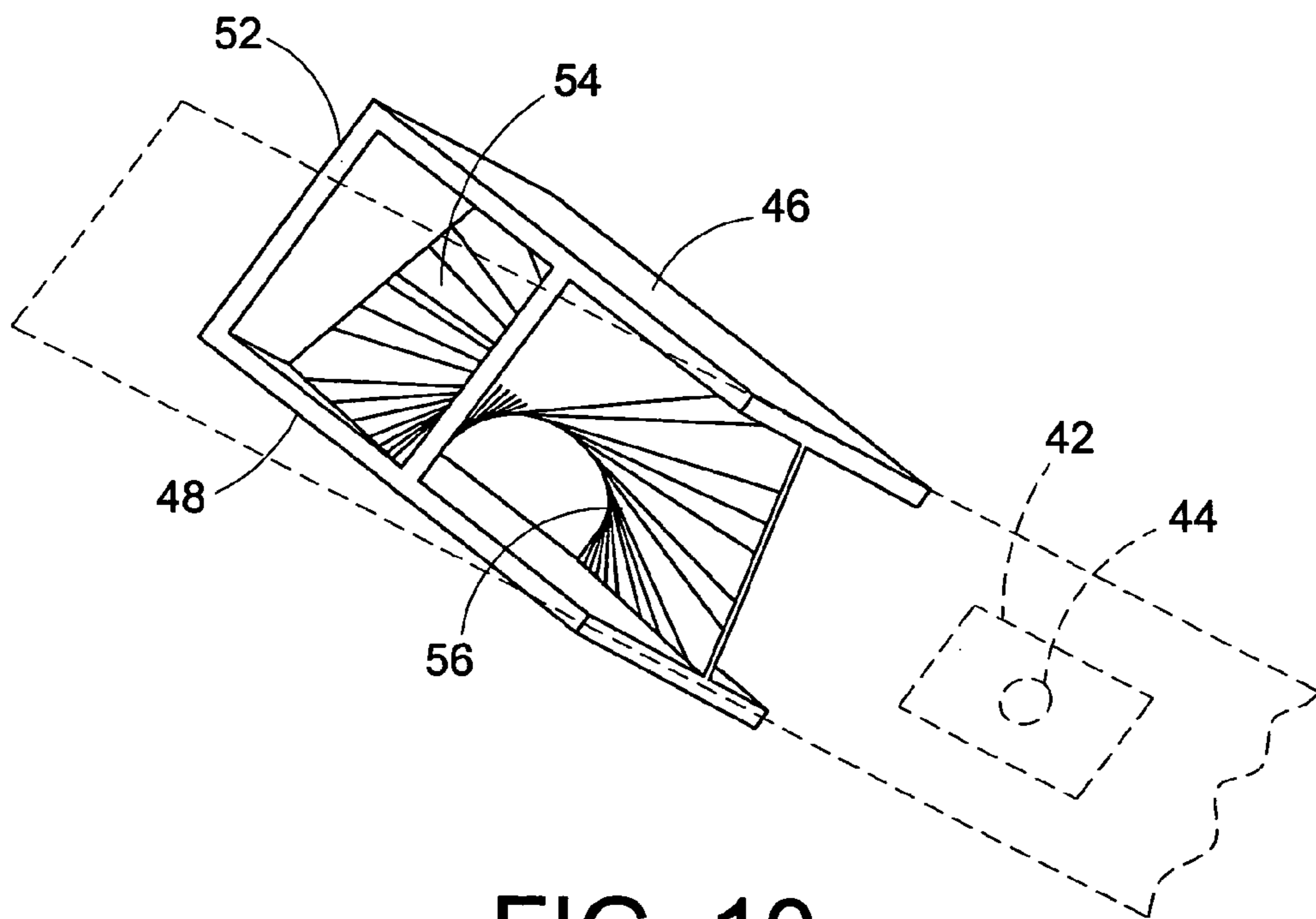

FIG. 10

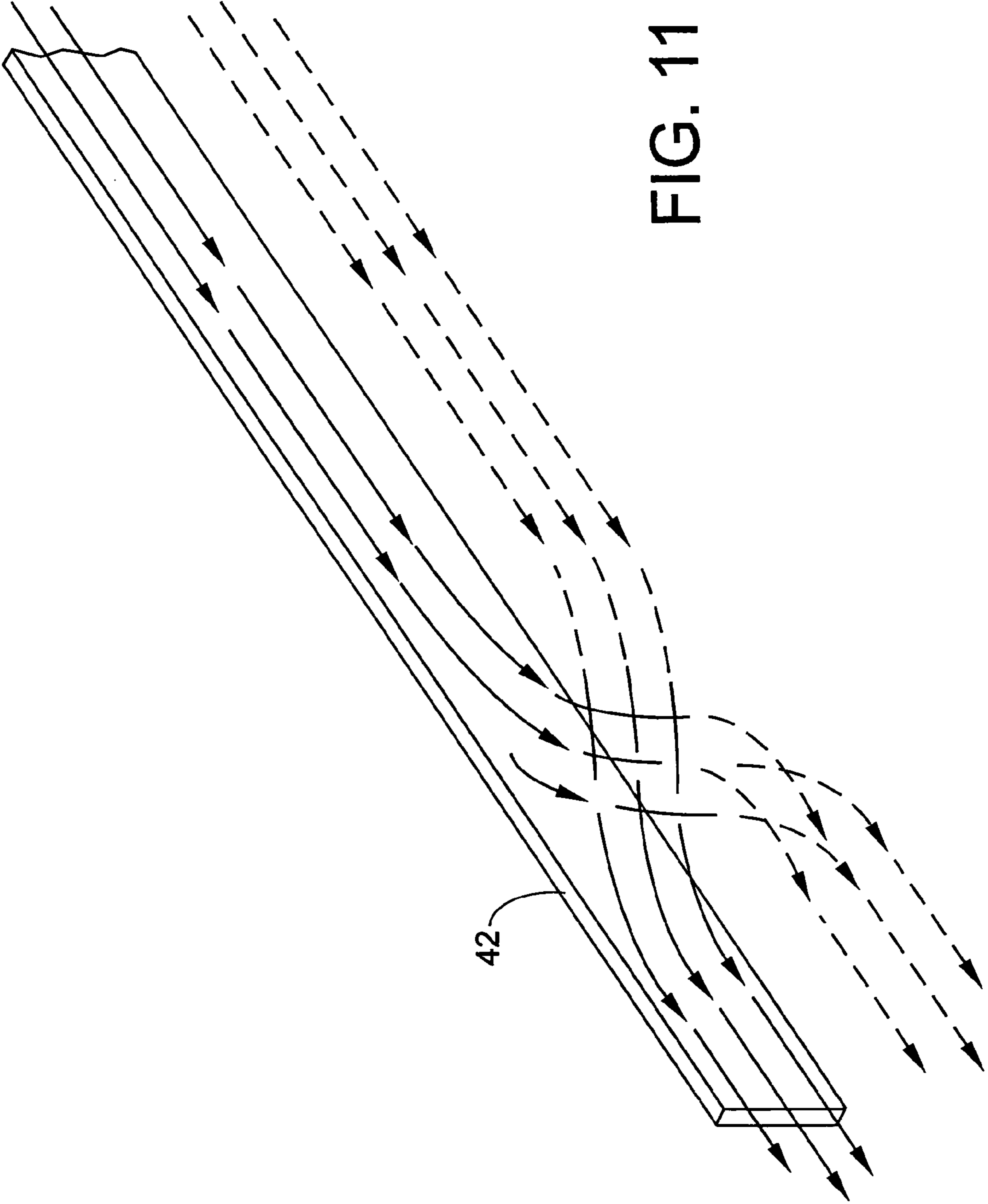

FIG. 11

1

METHOD AND APPARATUS FOR INCREASING NATURAL CONVECTION EFFICIENCY IN LONG HEAT SINKS

BACKGROUND OF THE INVENTION

Heat sinks are used to cool electrical devices, such as chips, diodes, and the like. Air, or some other fluid, flows over heat dissipation surfaces of the heat sink to cool the heat sink, and thus the electrical device. The heat transfer is mainly by way of convection.

Generally, natural convection is the cooling of a vertical hot surface in a large quiescent body of air. Lower-density air next to the vertical hot surface moves upward because of the buoyant force of higher-density cooler air farther away from the vertical surface. Movement of the air adjacent the vertical surface increases in velocity from zero at the vertical surface to a maximum velocity at a distance from the vertical surface and then decreases back to a velocity of zero as ambient surrounding conditions are reached. The temperature of the moving air decreases from the heated surface temperature to the ambient air temperature. As the temperature of the moving air approaches the ambient, the velocity at which the air moves approaches zero. No heat flows, by conduction or convection, where the velocity and temperature gradients equal zero, thus this outer edge is referred to as the boundary layer.

Forced convection, where air is blown across a heated surface, results in a maximum air velocity at the outer edge of the boundary layer. The difference in the velocity profile and the higher velocities provide more air near the heated surface and very thin boundary layers. Natural convection forces are present; however, the natural convection forces are negligible.

Forced convection may remove more heat than natural convection, but forced convection requires a device to move the air. In small electronic packages or where it is desirable to minimize the amount of energy expended to cool the electronic components, forced convection may be undesirable.

In free or natural convection, a tall heat sink tends to mix air inadequately with the surroundings resulting in the local ambient temperature around the heat sink to be hotter at the top of the heat sink as compared to the bottom of the heat sink, especially in laminar flow regimes. With reference to FIG. 1, a long, tall vertically-oriented heat sink 10 creates natural convection by heating the air around heat sink fins 12. This air then rises, creating an airflow that removes heat from the heat sink 10. For the section near the top of the heat sink, the local ambient air temperature is warmer than the air entering at the bottom of the heat sink 10. Although the heat sink is removing heat generated by electrical components 14 (FIG. 2) by natural convection, this local temperature rise near the top of the heat sink can have adverse effects on cooling, thus resulting in adverse effects on the electronic components mounted near the top of the heat sink.

SUMMARY OF THE INVENTION

An electrical apparatus that is cooled via natural convection includes an electrical component, a vertical heat dissipation surface in thermal communication with the electrical component, and a diverter extending from the heat dissipation surface. The diverter disrupts laminar vertical airflow over the heat dissipation surface.

A method for cooling an electrical component using natural convection comprises the following steps: attaching

2

an electrical component to a vertically oriented heat sink having a heat dissipation surface, introducing power into the electrical component such that the electrical component heats the heat sink generating upward laminar flow via natural convection over the heat dissipating surface, and disrupting the upward laminar flow over the heat dissipating surface.

A heat sink for an electrical component includes a heat sink body and a diverter. The heat sink body is adapted to have an associated electrical component mounted to the heat sink body, and the diverter is in thermal communication with the heat sink body. The diverter includes a first curved surface shaped to direct airflow toward the heat sink body and a second curved surface shaped to direct airflow away from the heat sink body.

BRIEF DESCRIPTION OF THE DRAWINGS

FIG. 1 is a rear perspective view of a known heat sink in thermal communication with an electrical component.

FIG. 2 is a front perspective view of the heat sink of FIG. 1 showing the electrical components mounted to the heat sink.

FIG. 3 is a close-up schematic view of airflow over a fin of the heat sink of FIG. 1.

FIG. 4 is a rear perspective view of a heat sink including a plurality of diverters.

FIG. 5 is a side view of a heat dissipation surface of a heat sink having diverters mounted on the surface.

FIGS. 6A–6D are views of the diverter of FIG. 5.

FIG. 7A–7F are some alternative embodiments of diverters.

FIG. 8 is a schematic view of a refrigerated compartment having a heat sink.

FIG. 9 is an upper perspective schematic view of a diverter attached to a heat sink.

FIG. 10 is a lower perspective schematic view of a diverter attached to a heat sink, with the heat sink and an electrical component shown in phantom.

FIG. 11 is a perspective view of a model of airflow through the diverter of FIG. 9.

DETAILED DESCRIPTION

With reference to FIG. 4, a heat sink 20 for cooling electrical components, for example LEDs, (not shown but similar to components 14 in FIG. 2) is provided. The heat sink 20 generally includes a base 22 having a plurality of fins 24 extending from the base. Electrical components can mount to the base on a mounting surface (not shown) that is opposite the fins 24. Alternatively, the electrical components can mount to other surfaces that are in thermal communication with a heat dissipation surface 26. In this embodiment, the fins 24 along with the rear side of the base 22 provide the heat dissipation surface 26 over which air flows to remove heat from the heat sink 20.

In this particular embodiment, a long, vertically oriented heat sink 22 is provided to generate upward laminar flow via natural convection. Although not to be bound by theory, computer modeling has indicated that a long heat sink, i.e. a heat sink where the vertical dimension is about ten times the remaining two dimensions, is capable of generating upward laminar airflow via natural convection on the order of one meter per second when appropriate heating is applied. Nevertheless, not only are heat sinks where the vertical dimension is ten times the remaining two dimensions contemplated, shorter heat sinks, for example where the vertical

dimension is about five times or even two times the remaining two dimensions, may achieve adequate results.

A plurality of diverters **28** mount to the heat dissipation surface **26** of the heat sink **20**. The diverters **28** are vertically spaced from one another. The diverters **28** can also be horizontally spaced from one another. The mounting surface **26** can include designated mounting locations **32** where the diverters **28** can attach to the heat dissipating surface **26**. The mounting locations **28** can include holes that receive fasteners, or can simply include a marked location. According to the embodiment having mounting locations, the diverters **28** can be selectively removable from the heat dissipating surface **26**.

With reference to FIG. 6, the diverters **28** are shown as ramps. With reference to FIG. 5, the diverters **28** disrupt the upward laminar flow of air across the heat dissipation surface **26** resulting in turbulent airflow adjacent the diverter. The turbulent airflow reduces the overall temperature of the ambient air adjacent the heat sink by mixing in cooler airflow located away from the heat sink. The diverter **28** can be shaped to create turbulent airflow that escapes the boundary layer of laminar flow generated by natural convection. Accordingly, heat can be dissipated across the laminar flow boundary layer and mixing the cooler surrounding air with the hotter air adjacent the heat dissipation surface **26**. The diverters can also disrupt generally upward flow in the turbulent regime and the transitional regime. The diverters disrupt all three kinds of flow moving air outside of the boundary layer to promote heat transfer across the boundary layer.

With reference to FIG. 7 alternative configurations of diverters are shown. In some embodiments, the diverter includes a curved upstream surface. In other embodiments, the diverter comprises a thin plate like member. Although many different configurations are disclosed in the figures, the diverters can take any configuration that adequately disrupts the vertical flow.

With reference to FIG. 8, the heat sink **20** is situated in a refrigerated compartment **32**. The heat sink **20** is long and narrow, similar to those described above, and typically mounts to a mullion of the refrigerated compartment **32**. The refrigerated compartment **32** can include a refrigerator, a freezer, or other compartment typically found in supermarkets, convenience stores and the like. Lights **36** are used to illuminate the item stored on the shelves **34**. The heat sink **20** includes a heat dissipation surface **26** and diverters **28**. The diverters **28** can also be similar to any of those described above.

With reference to FIGS. 9 and 10, another embodiment of a diverter **40** is shown. The diverter **40** attaches to and is in thermal communication with a heat sink **42** that has an electrical component **44** (FIG. 10) mounted to the heat sink, similar to the embodiments disclosed above. The diverter **40** of this embodiment exchanges relatively hot air with cool air by moving outer cooler air toward the heat sink **42** and moving inner hotter air away from the heat sink.

The diverter **40** includes two generally parallel side walls **46** and **48** that are spaced from one another. The side walls **46**, **48** extend away from and are generally perpendicular to the heat sink **42**. A top or outer wall **52** connects the side walls **46** and **48** and is generally parallel to and spaced from the surface of the heat sink **42** to which the diverter mounts. The top wall **52** and side walls **46**, **48** confine air as it moves through the diverter **40**.

The diverter **40** also includes an upper or outer wall defining a first curved surface **54** that directs the flow of cooler outer air towards the heat sink **42** and a lower or inner

wall that defines a second curved surface **56** that directs the flow of hotter inner air away from the heat sink **42**. In this embodiment, the movement of air through the diverter **40** can be described as a 180 degree rotation, in that the cooler outer air is directed to occupy the space that would have been occupied by the hotter inner air and the hotter inner air is directed to occupy the space that would have been occupied by the cooler outer air, had there been no diverter.

The exact shape of the curved walls **54** and **56** is not critical. The curved walls are shown as emanating at a common line at a vertical midpoint between the heat sink **42** and the top wall **52** along the side walls **46** and **48** of the diverter; however, the curved walls can emanate at any location along the side walls. The curve of the curved walls **54** and **56** is simply to encourage the mixing of hot and cold air.

With reference to FIG. 11, airflow through the diverter (which is not depicted in FIG. 11 for reasons of clarity) is shown. As can be seen, outer air particles that are spaced from the heat sink **42** move toward the heat sink and inner air particles that are spaced adjacent the heat sink move away from the heat sink. The airflow returns to laminar flow downstream from the diverter **40**.

It has been found that an appropriately dimensioned heat sink, when appropriate heating is applied, can generate enough air velocity simply via natural convection to incorporate the benefits of providing diverters on the heat sink so that the need for fans, and the like, to promote airflow can be obviated. The heat sink has been described with reference to preferred embodiments; obviously alterations will occur to others upon reading and understanding the detailed description. The invention is not limited to only those embodiments described in the preceding description; the invention is only limited to the appended claims and the equivalents thereof.

The invention claimed is:

1. A refrigerated apparatus comprising:

a refrigerated compartment;

a heat sink disposed in the refrigerated compartment, the heat sink including a heat dissipation surface having a vertical dimension greater than a horizontal dimension; an LED mounted to and in thermal communication with the heat sink; and

a diverter extending from the heat dissipation surface, the diverter being positioned to disrupt vertical airflow over the heat dissipation surface and being shaped to generate turbulent airflow outside of a boundary layer of vertical airflow over the heat dissipation surface generated by natural convection.

2. The apparatus of claim 1, wherein the vertical dimension is at least about 10 times a first horizontal dimension of the heat dissipation surface.

3. The apparatus of claim 2, wherein the vertical dimension is at least about 10 times a second horizontal dimension of the heat dissipation surface.

4. The apparatus of claim 1, wherein the diverter extends substantially horizontally on the heat dissipation surface.

5. The apparatus of claim 1, wherein the diverter comprises a ramp.

6. The apparatus of claim 5, wherein the ramp comprises a curved upstream surface.

7. The apparatus of claim 1, wherein the diverter comprises a thin planar member or a thin curved member.

8. The apparatus of claim 1, further comprising a plurality of diverters extending from the heat dissipation surface.

5

9. The apparatus of claim 1, wherein the heat dissipation surface includes a plurality of designated diverter mounting locations.

10. The apparatus of claim 9, wherein the diverter mounting locations comprise openings in the heat dissipation surface.

11. The apparatus of claim 9, wherein the diverter is selectively removable from the diverter mounting location.

12. The apparatus of claim 1, further comprising a plurality of long, vertical heat dissipation surfaces in thermal communication with the LED, wherein at least some of the heat dissipation surfaces have diverters extending therefrom.

13. A method for cooling an electrical component using natural convection, the method comprising:

attaching an electrical component to a vertically oriented heat sink including a heat dissipation surface having a vertical dimension greater than a horizontal dimension; introducing power into the electrical component such that the electrical component heats the heat sink generating upward laminar flow via natural convection over the heat dissipating surface; and

absent forced convection, disrupting the upward laminar flow over the heat dissipating surface to generate turbulent airflow outside of a boundary layer of the upward laminar flow.

6

14. The method of claim 13, wherein the step of disrupting the upward laminar flow further comprises passing air through a diverter in thermal communication with the heat sink and directing air that is spaced a predetermined distance from the heat sink toward the heat sink and directing air that is adjacent the heat sink away from the heat sink.

15. A heat sink for an electrical component comprising: a heat sink body adapted to have an associated electrical component mounted to the heat sink body; and a diverter in thermal communication with the heat sink body, wherein the diverter includes a first curved surface shaped to direct airflow toward the heat sink body and a second curved surface shaped to direct airflow away from the heat sink body.

16. The heat sink of claim 15, wherein the first curved surface and the second curved surface emanate from a common line.

17. The heat sink of claim 15, wherein the diverter includes first and second side walls attached to the first curved surface and the second curved surface.

18. The heat sink of claim 17, wherein the diverter includes a third side wall connected to and generally perpendicular with the first and second side walls.

* * * * *