



US007080304B2

(12) **United States Patent**  
**Reese**

(10) **Patent No.:** **US 7,080,304 B2**  
(45) **Date of Patent:** **Jul. 18, 2006**

(54) **TECHNIQUE FOR PROGRAMMING  
CLOCKS IN AUTOMATIC TEST SYSTEM**

2002/0023239 A1 \* 2/2002 Nomura et al. .... 713/500

**FOREIGN PATENT DOCUMENTS**

(75) Inventor: **Gilbert R. Reese**, Boston, MA (US)

WO WO94/02861 A1 2/1994

(73) Assignee: **Teradyne, Inc.**, Boston, MA (US)

WO WO96/28745 A2 9/1996

WO WO01/28100 A1 4/2001

(\*) Notice: Subject to any disclaimer, the term of this patent is extended or adjusted under 35 U.S.C. 154(b) by 576 days.

**OTHER PUBLICATIONS**

(21) Appl. No.: **10/083,009**

S. Max, "Direct AWG Sine Wave Synthesis with Fixed Clock Frequency", May 1-4, 2000, Proceedings of 17th IEEE, vol. 1 pp230-234.\*

(22) Filed: **Feb. 26, 2002**

International Search Report, Mailing Date Aug. 18, 2003.

(65) **Prior Publication Data**

US 2003/0163775 A1 Aug. 28, 2003

Mehtani, R. et al, "Mix Test: A Mixed-Signal Extension to a Digital Test System," Proceedings from International Test Conference 1993, New York NY, Oct. 17, 1993, IEEE, pp. 945-953.

(51) **Int. Cl.**  
**G06F 11/00** (2006.01)

\* cited by examiner

(52) **U.S. Cl.** ..... **714/744; 702/125; 713/500; 708/271**

*Primary Examiner*—Albert Decady  
*Assistant Examiner*—John P. Trimmings

(58) **Field of Classification Search** ..... **714/724, 714/731, 740, 744, 814; 702/120, 125; 713/500; 708/271**

(57) **ABSTRACT**

See application file for complete search history.

A system and method for configuring an automatic test system to produce a plurality of clocks from a reference clock includes a user interface and software. The user interface receives a plurality of inputs that specify desired frequencies of the plurality of clocks. In response to a command from the user interface, the software calculates values for dividers coupled to the reference clock, for deriving each of the desired frequencies from the reference clock. According to one embodiment, the desired frequencies form ratios that must be met to satisfy coherence. In calculating the divider values, the software minimizes frequency errors while precisely preserving the required ratios.

(56) **References Cited**

**U.S. PATENT DOCUMENTS**

- 4,598,257 A \* 7/1986 Southard ..... 331/2
- 5,719,510 A 2/1998 Weidner
- 5,905,967 A \* 5/1999 Botham ..... 702/118
- 6,223,298 B1 \* 4/2001 Tellier et al. .... 713/501
- 6,333,940 B1 \* 12/2001 Baydar et al. .... 370/506
- 6,449,741 B1 \* 9/2002 Organ et al. .... 714/724
- 6,675,339 B1 \* 1/2004 Lanier et al. .... 714/744

**28 Claims, 9 Drawing Sheets**

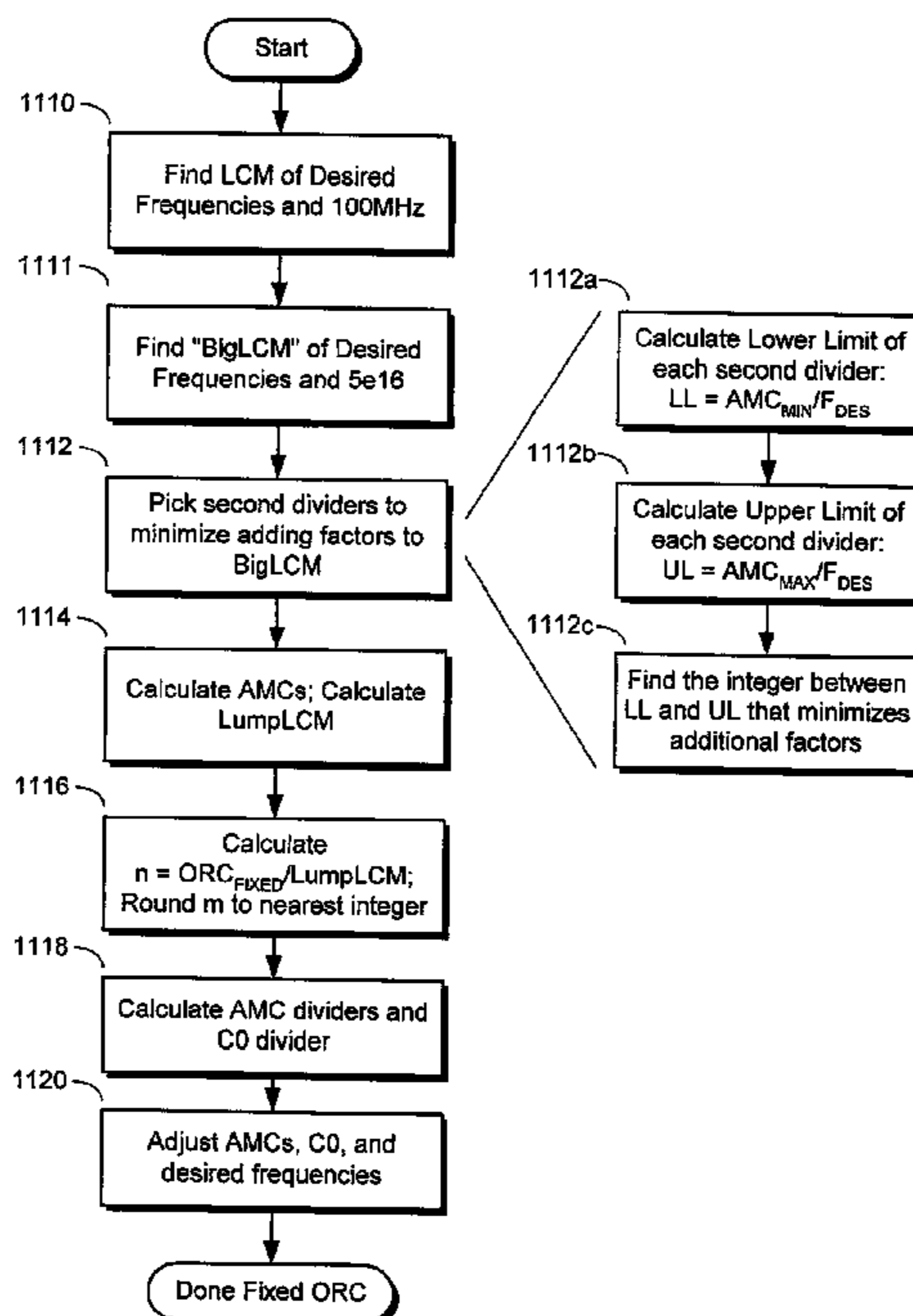

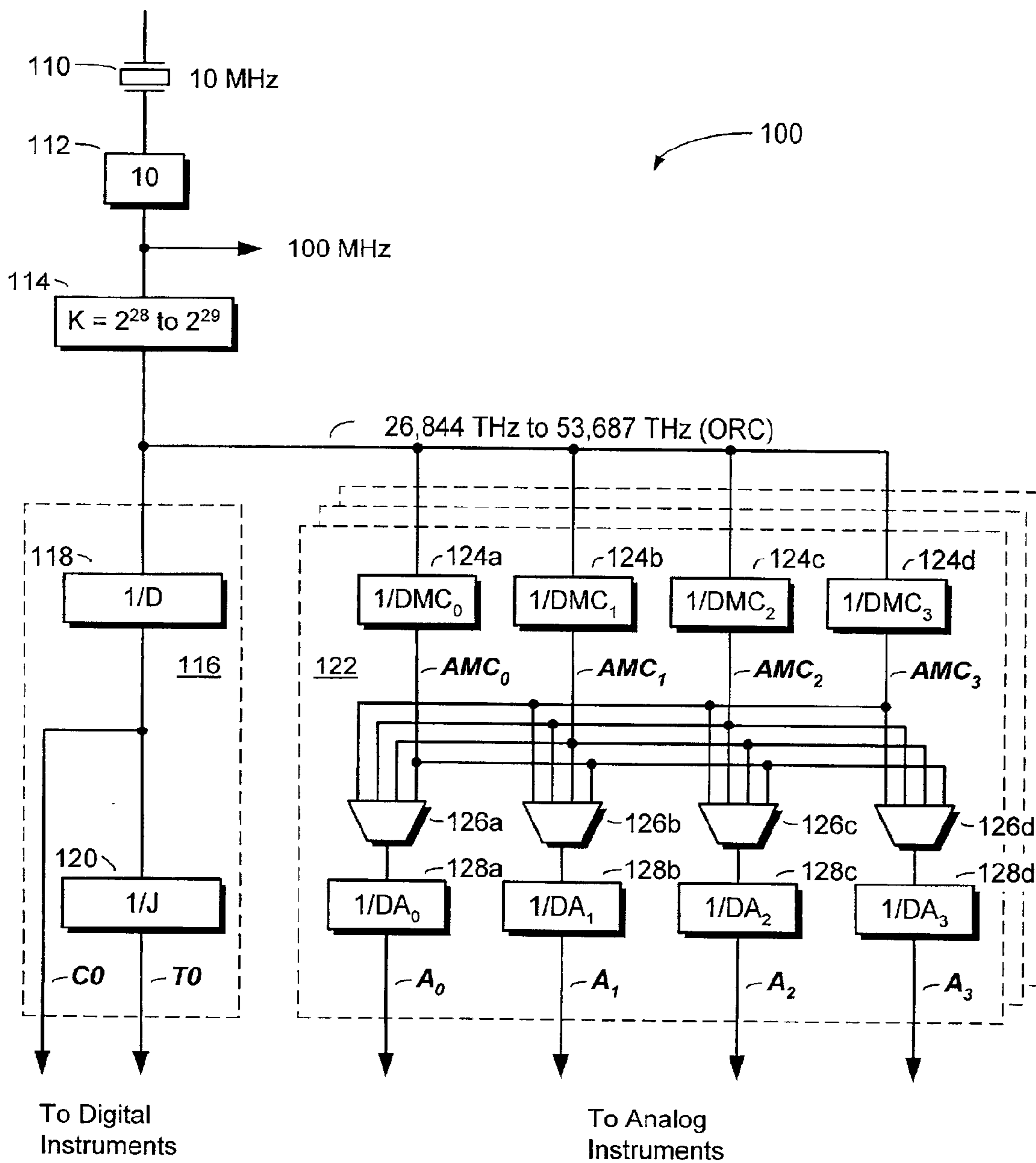

Fig. 1

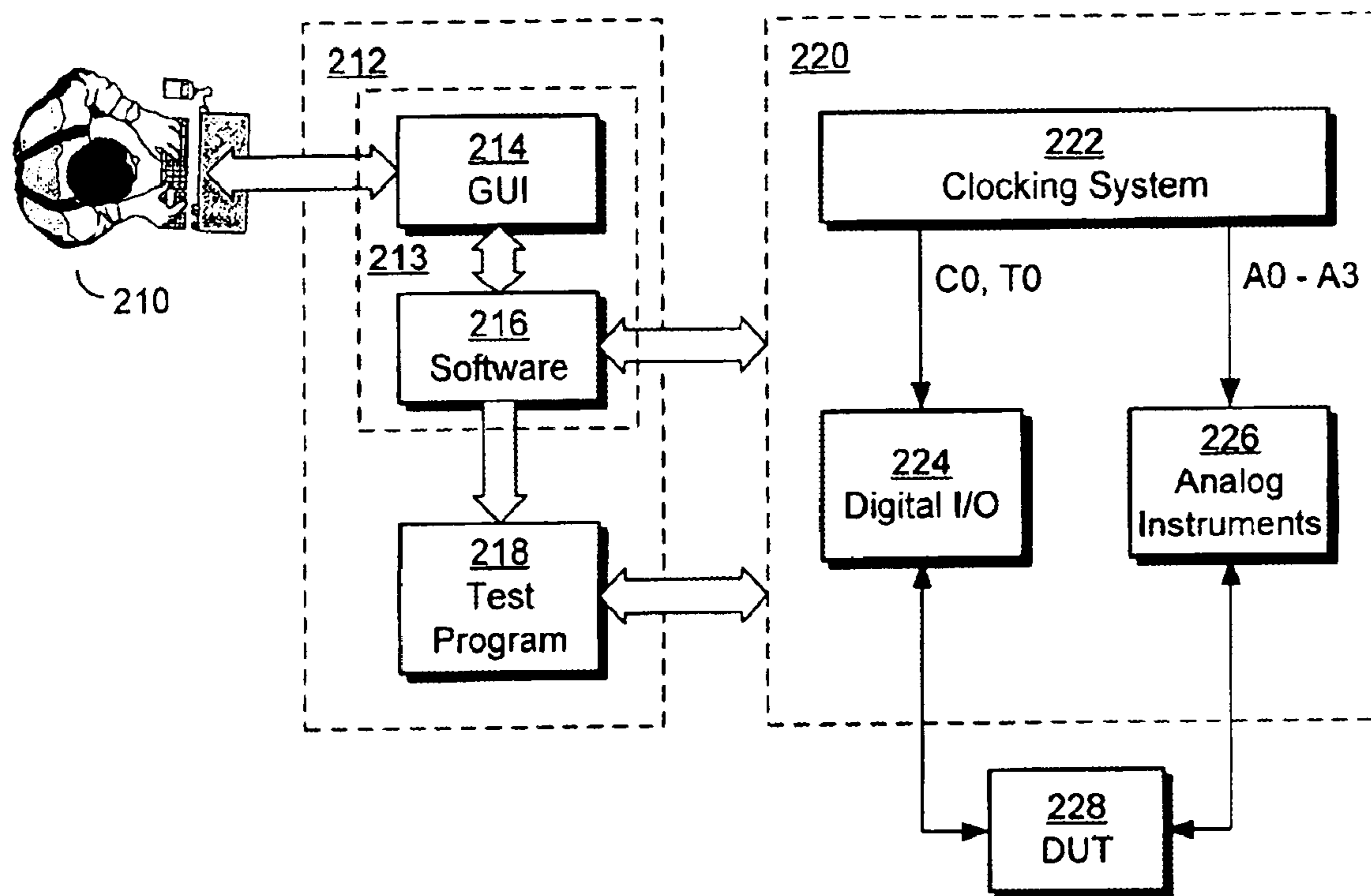

Fig. 2

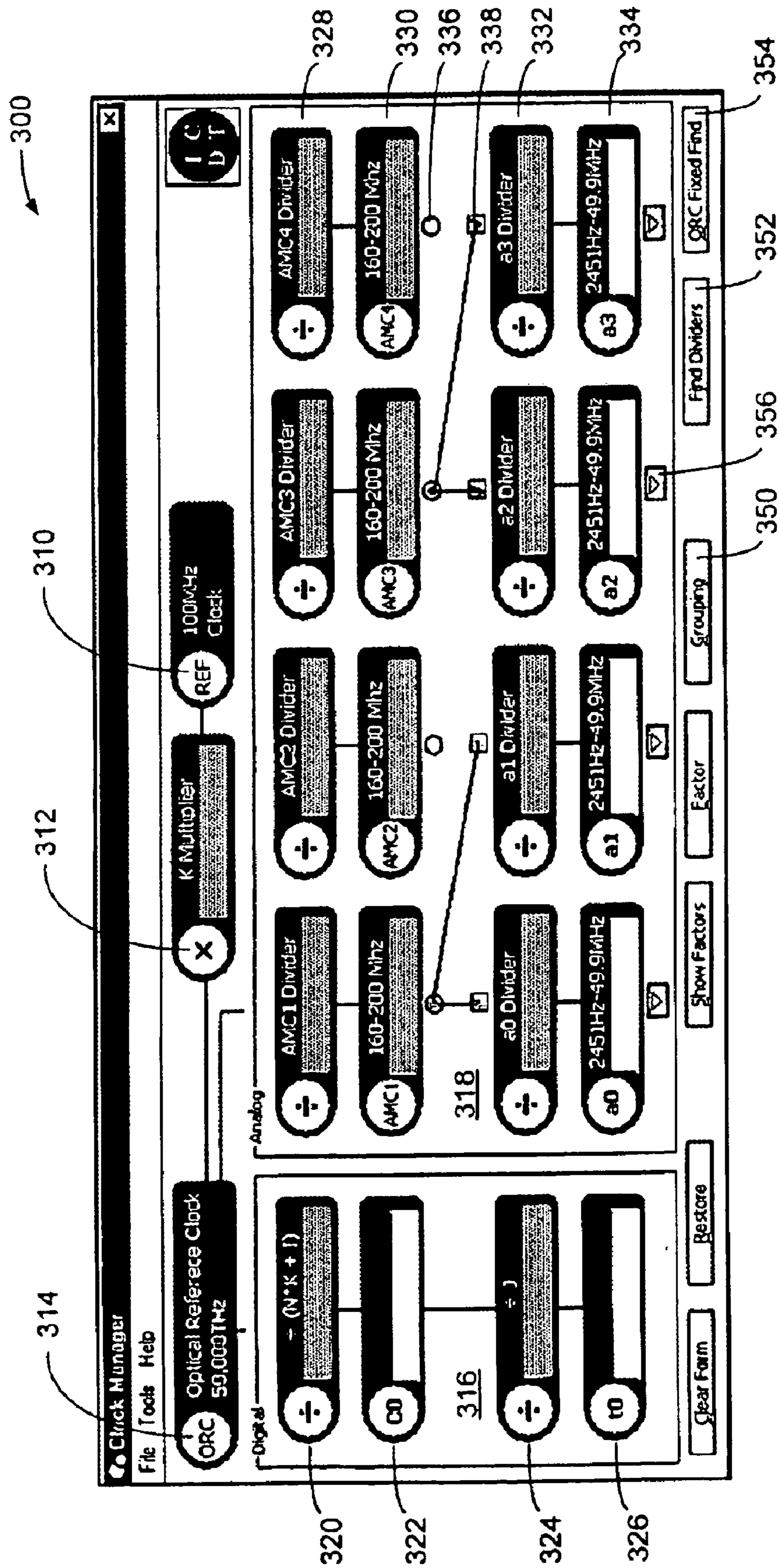

Fig. 3

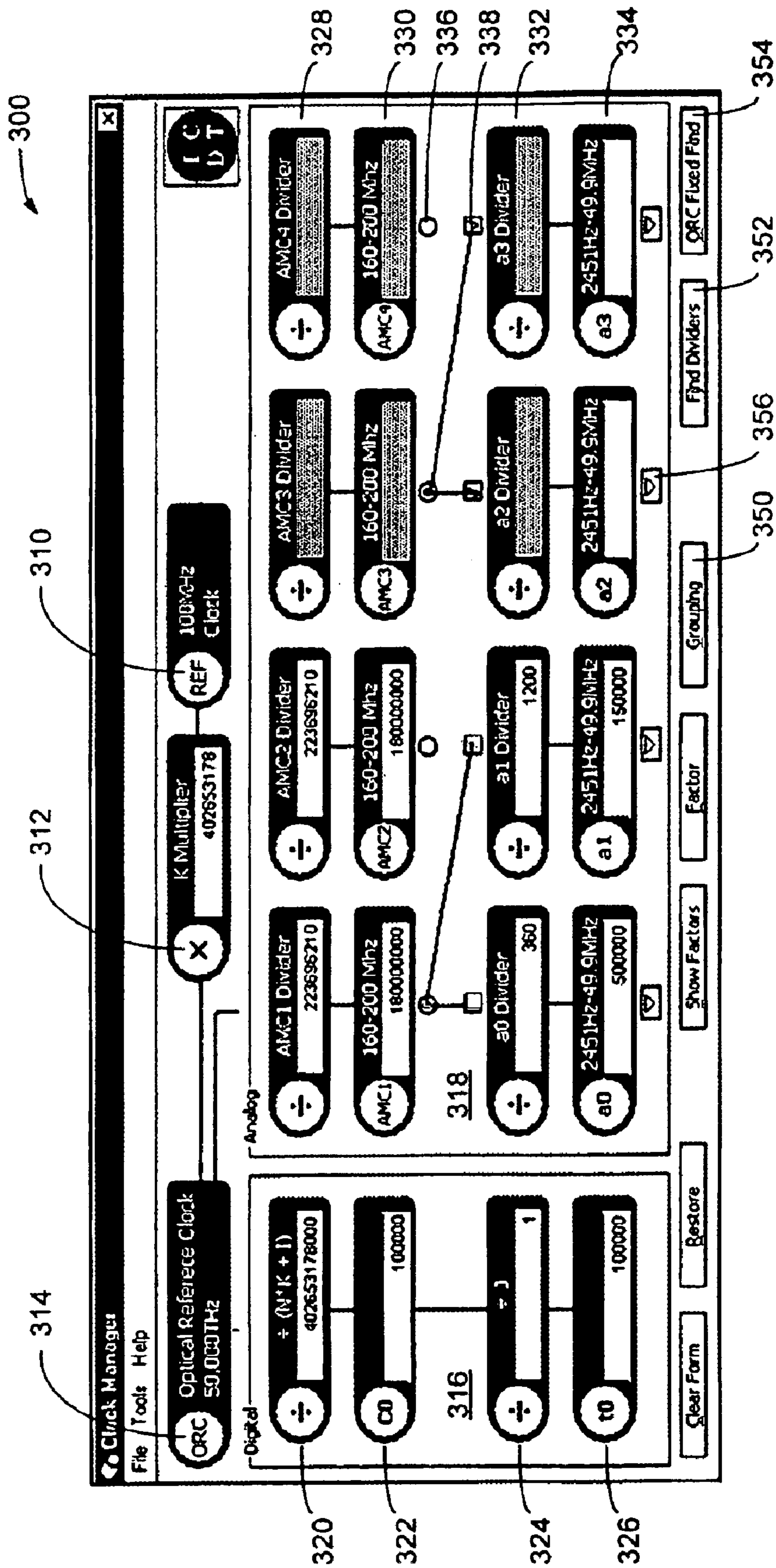

Fig. 4

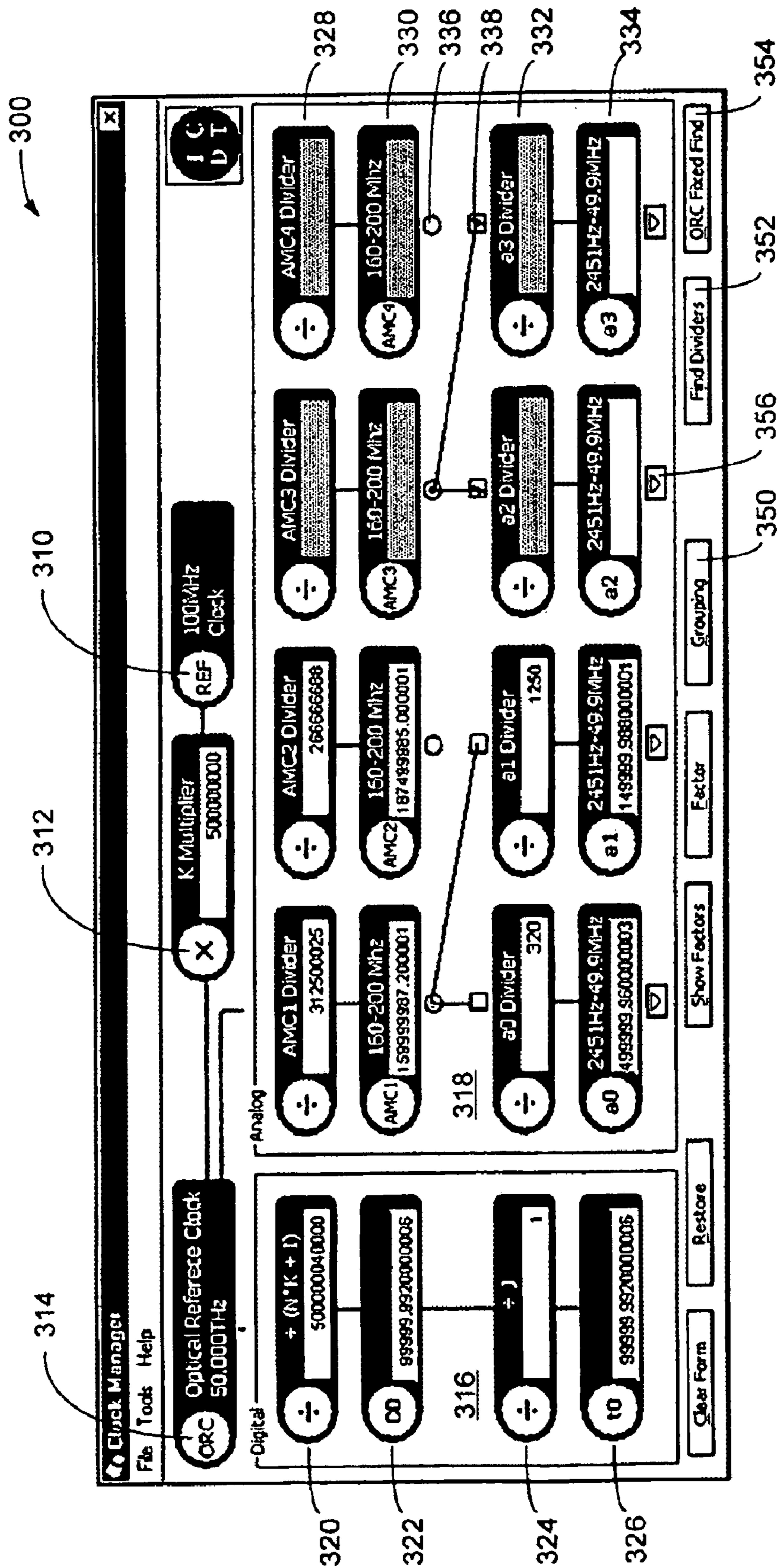

Fig. 5

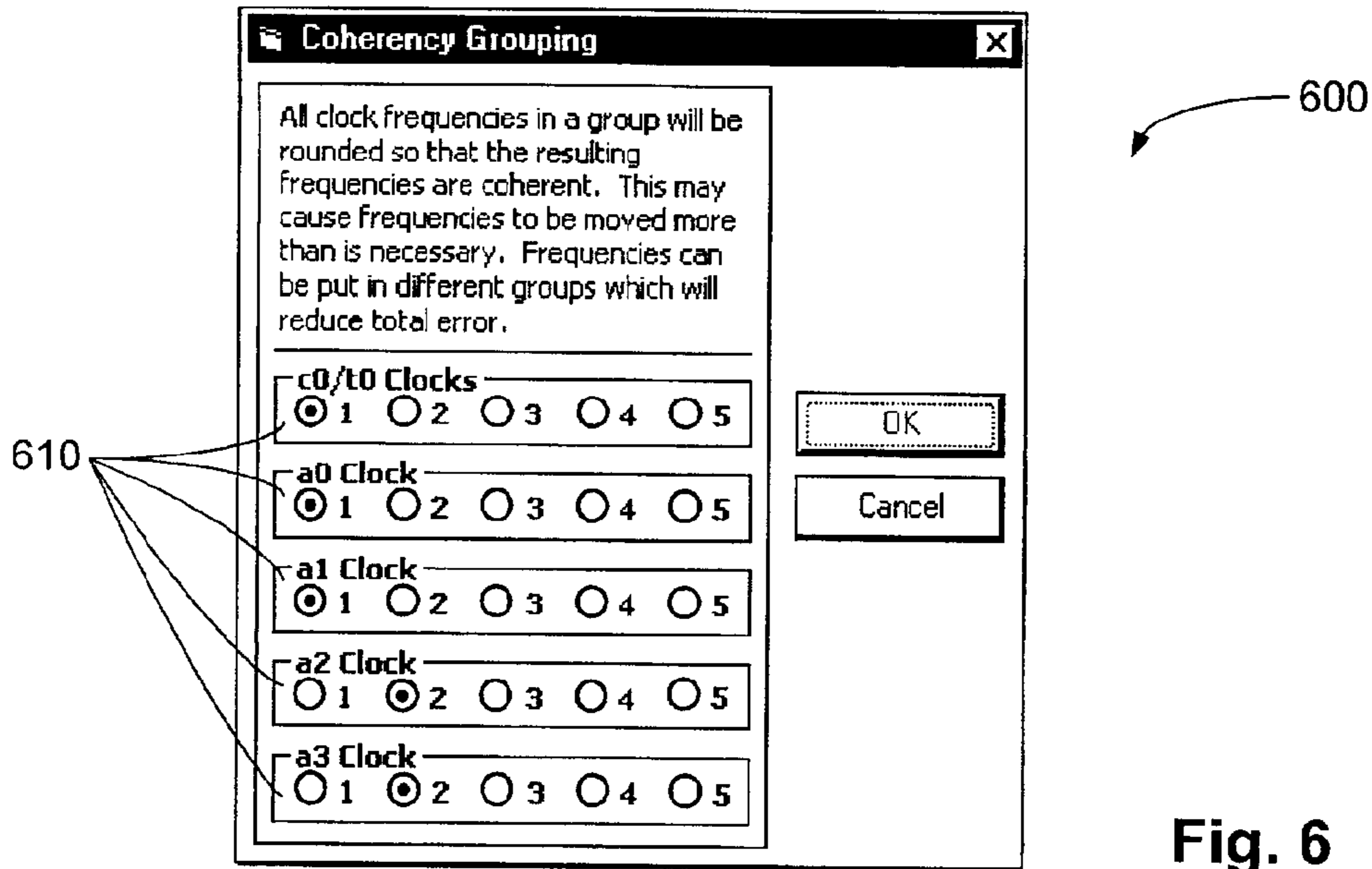

Fig. 6

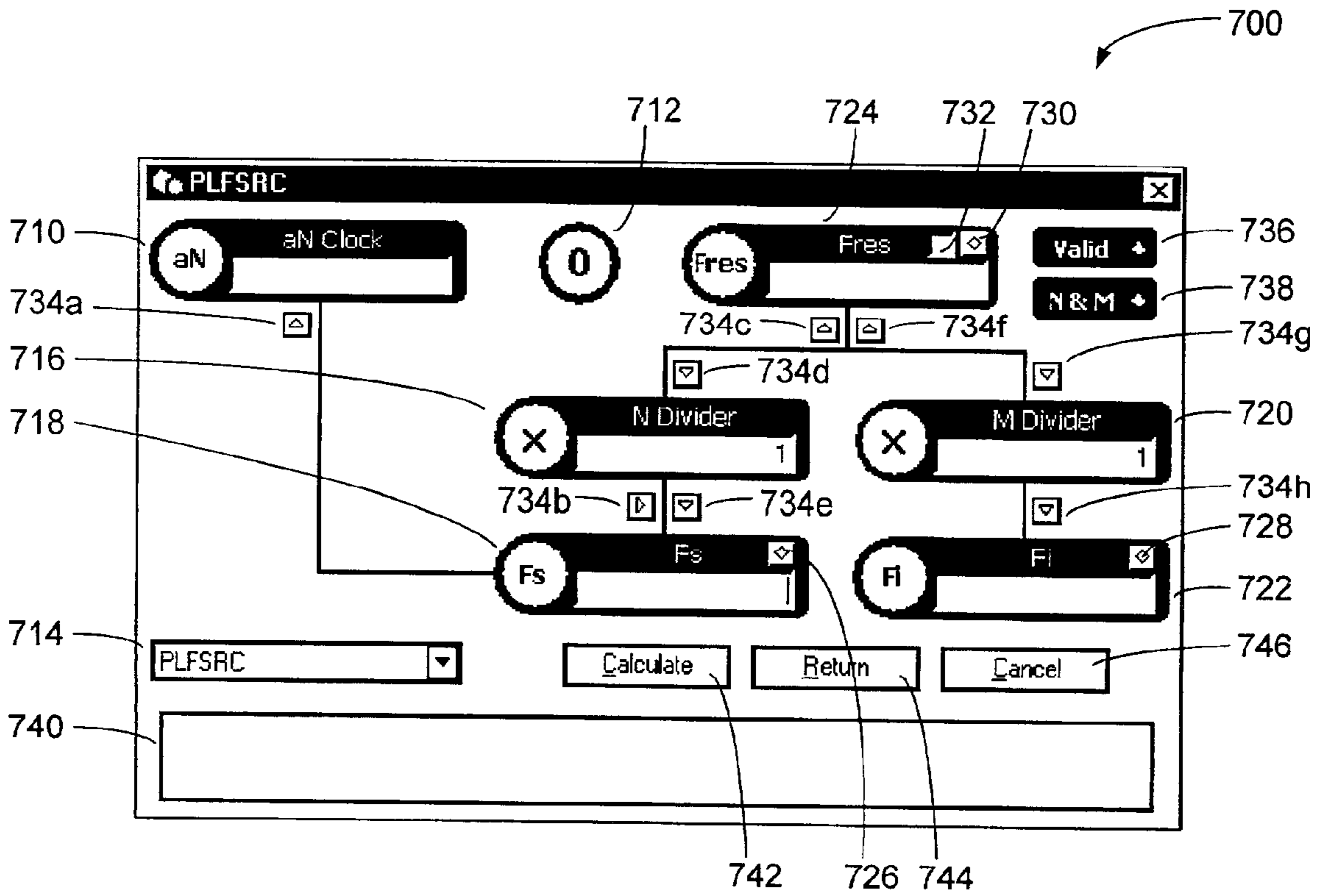

Fig. 7

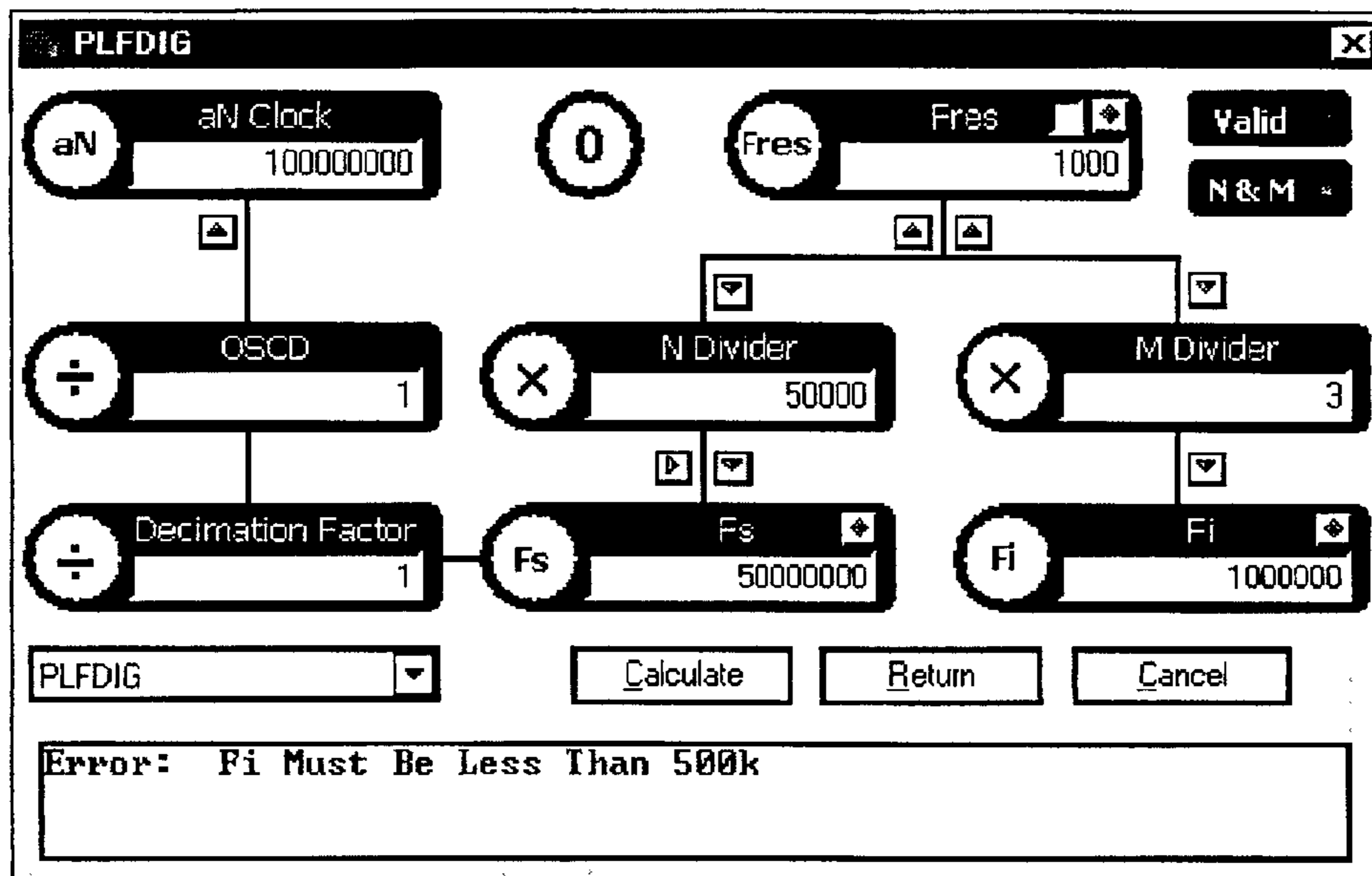

Fig. 8

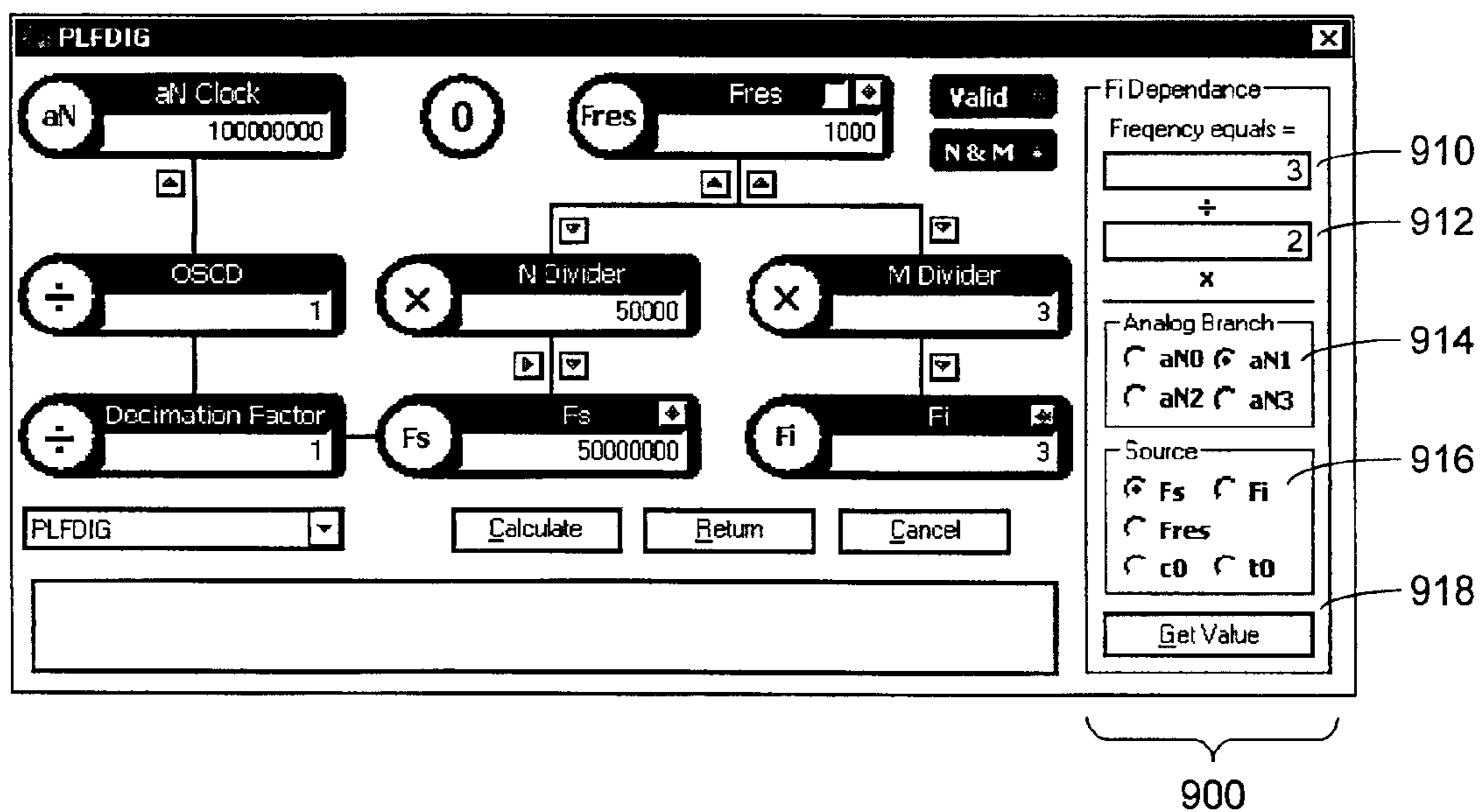

Fig. 9



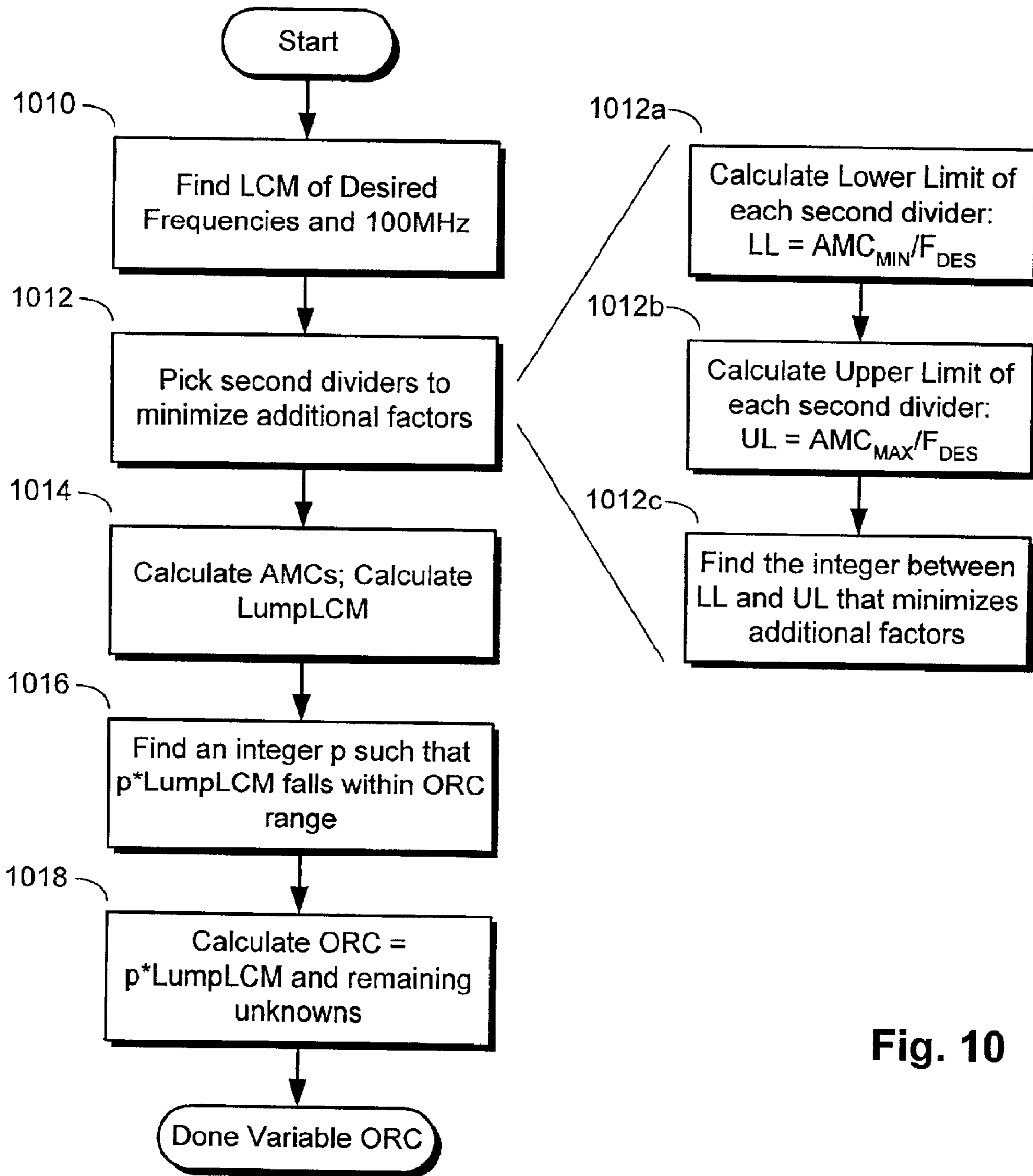

Fig. 10

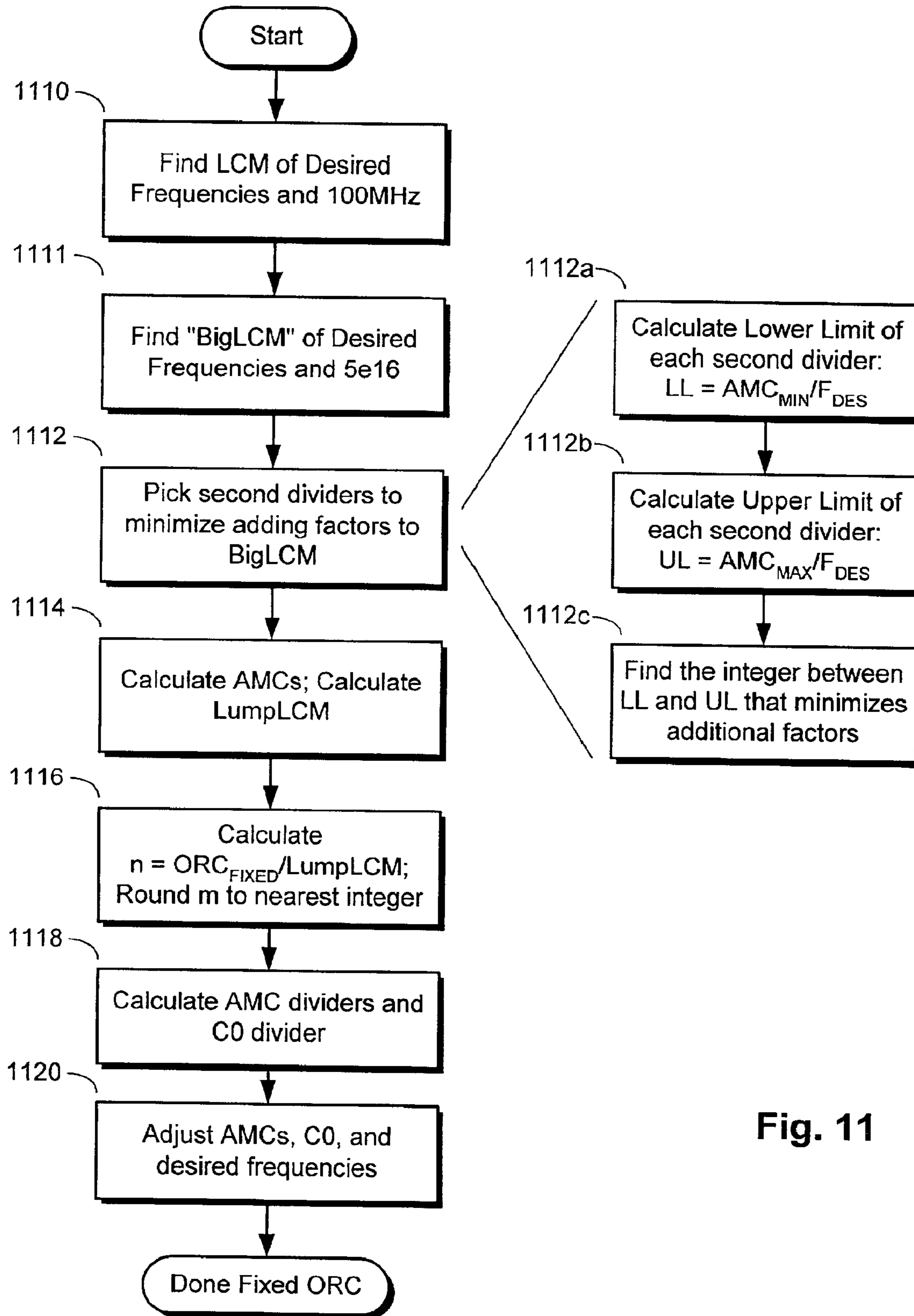

Fig. 11

1

## TECHNIQUE FOR PROGRAMMING CLOCKS IN AUTOMATIC TEST SYSTEM

### CROSS-REFERENCES TO RELATED APPLICATIONS

Not Applicable.

### STATEMENT REGARDING FEDERALLY SPONSORED RESEARCH OR DEVELOPMENT

Not Applicable.

Reference to Microfiche Appendix

Not Applicable

### BACKGROUND OF THE INVENTION

#### 1. Field of the Invention

This invention relates generally to automatic test equipment (ATE) for electronics, and, more particularly, to techniques for programming multiple clocks in an automatic test system.

2. Description of Related Art Including Information Disclosed under 37 C.F.R. 1.97 and 1.98

ATE systems typically use multiple clocks for testing electronic devices. In a common testing scenario, three or more clocks may be used—for example, a digital clock, a source clock, and a capture clock. The digital clock defines the rate at which digital I/O applies digital signals to the DUT (device under test), or samples digital signals from the DUT. The source clock defines the rate at which an analog source, such as an AWG (arbitrary waveform generator), varies the output levels of analog signals applied to the DUT. The capture clock defines the rate at which a digitizer samples analog signals from the DUT.

Device testing generally requires that different clocks of a test system be coordinated. When testing a DAC (digital-to-analog converter), the digital clock is coordinated with the capture clock to ensure that the digitizer samples the DAC's output at known points referenced to the DAC's input codes. Similarly, when testing an ADC (analog-to-digital converter), the digital clock is coordinated with the source clock to ensure that digital readback from the ADC is referenced to known points along the analog input signal.

It is particularly important to coordinate clocks for achieving "coherence." A signal is coherent when each tone in the signal completes an integer number of cycles within the sample window. Mathematically, coherence is achieved when  $F_s/N = F_{ik}/M_k$ , where

$F_s$  is the instrument's sampling rate;

$N$  is the number of samples in the sample window (sourced or captured);

$F_{ik}$  is the frequency of interest (output or expected) of the  $k^{th}$  tone; and

$M_k$  is the number of cycles that the  $k^{th}$  tone completes within the sample window.

The need for coherence arises when two or more clocks are involved in a single test, for example, when one clock controls the sourcing of an input signal and another clock controls the capture of an output signal that contains the same frequencies as the input signal. Without coordination, it would be impossible to guarantee that  $F_s/N = F_{ik}/M_k$ , and thus to guarantee coherence.

Coherence is important for preventing "leakage." Leakage is the mathematical consequence of sourcing or sam-

2

pling truncated tones. Leakage adds harmonic distortion to sourced signals and distorts the DFT's (Discrete Fourier Transforms) of sampled signals. Therefore, leakage impairs a test system's ability to test device characteristics accurately.

Test engineers conventionally apply their knowledge of a test system's clocking system and instruments ascertain clock frequencies manually. Clocking systems and instruments can be extremely complex, however, imposing constraints that limit the flexibility with which timing can be prescribed. Therefore, test engineers must conventionally have a high degree of expertise to configure the clocks of a test system successfully.

Difficulties in prescribing a test system's clocks are compounded when a test setup requires coherence. Coherence imposes the additional constraint that two or more clocks in a tester must have a fixed frequency ratio. Oftentimes, constraints in the clocking system or instruments make it impossible to achieve this ratio at the specific frequencies that the test engineer wishes to use. To work around these constraints, the test engineer generally searches for nearby frequencies that the test system can produce, which also meet the required ratio. This task often comes down to a time-consuming process of trial and error. In addition, nothing about this manual technique ensures that the frequencies ultimately used are the closest realizable frequencies, which meet the ratio constraint, to the originally desired frequencies. Therefore, the current technique does not necessarily minimize frequency errors.

What is needed is a simpler, more accurate technique for programming clocks in an automatic test system.

### BRIEF SUMMARY OF THE INVENTION

With the foregoing background in mind, it is an object of the invention to prescribe a configuration of multiple clocks in an automatic test system conveniently.

To achieve the foregoing object, as well as other objectives and advantages, a technique for configuring an automatic test system to produce a plurality of clocks from a reference clock includes a user interface for receiving a plurality of inputs that specify desired frequencies of the plurality of clocks. In response to a command from the user interface, software calculates values for dividers coupled to the reference clock, for deriving each of the desired frequencies from the reference clock.

According to one embodiment of the invention, the desired frequencies form ratios that must be met to satisfy coherence. In calculating the divider values, the software minimizes frequency errors while precisely preserving the required ratios.

### BRIEF DESCRIPTION OF THE SEVERAL VIEWS OF THE DRAWINGS

Additional objects, advantages, and novel features of the invention will become apparent from a consideration of the ensuing description and drawings, in which—

FIG. 1 is a simplified block diagram of the clocking system with which the system for configuring clocks may be used;

FIG. 2 is a simplified block diagram showing a tester environment in which a user can employ the system for configuring clocks;

FIG. 3 is an illustration of the Clock Manager Form, which forms part of a graphical user interface of the system for configuring clocks;

FIG. 4 is an illustration of the Clock Manager Form of FIG. 3, after the system is operated in variable ORC mode;

FIG. 5 is an illustration of the Clock Manager Form of FIG. 3, after the system is operated in fixed ORC mode;

FIG. 6 is an illustration of the Coherency Grouping Form, which can be accessed via a control on the Clock Manager Form;

FIG. 7 is an illustration of the Instrument Form, which can be accessed via one or more controls on the Clock Manager Form;

FIG. 8 is an illustration of the Instrument Form of FIG. 7, showing the selection of a different instrument from the one selected in FIG. 7;

FIG. 9 is an illustration of the Instrument Form of FIG. 7, showing a calculator portion for computing frequency dependencies;

FIG. 10 is a flowchart showing an algorithm for determining divider values for a clocking system using variable ORC mode; and

FIG. 11 is a flowchart showing an algorithm for determining divider values for a clocking system using fixed ORC mode.

#### DETAILED DESCRIPTION OF THE INVENTION

FIG. 1 is a simplified, equivalent block diagram of a clocking system 100 with which the system for configuring clocks may be used. The clocking system 100 corresponds to that of the Catalyst™ test system, which is manufactured by Teradyne, Inc., of Boston, Mass. Within the clocking system, a 10 MHz crystal oscillator 110 is frequency-multiplied, by a phase-locked loop 112, to produce a 100 MHz reference clock. The reference clock is frequency-multiplied by a K Multiplier 114 to produce an ultra-high resolution, optical reference clock (ORC). The ORC has both a fixed mode and a variable mode. In fixed ORC mode,  $K=500,000,000$ , which corresponds to an ORC frequency of 50,000 THz (1 Terahertz= $10^{12}$  Hz). In variable ORC mode, K is allowed to vary between  $2^{28}$  and  $2^{29}$ , which corresponds to an ORC that ranges between approximately 26,844 THz and 53,687 THz. Because it uses round numbers, fixed ORC mode is generally easier to program than variable ORC mode. Because it is more flexible, however, variable ORC mode more often produces coherent solutions precisely at desired frequencies.

The ORC effectively branches to a digital clocking system 116 and to one or more analog clocking systems 122. The digital clocking system 116 consists of a timing path that includes a first frequency divider 118 for dividing the ORC by an integer “D” to produce a first digital output clock C0. (also designated as c0 in FIGS. 3 to 9). A second divider 120 divides the first digital output clock C0 by an integer “J” to produce a second digital output clock T0. (also designated as t0 in the FIGS. 3 to 9) Digital clocks C0 and T0 can then be used to control the timing of digital vectors applied to or sampled from the DUT. The analog clocking system 122 includes four timing paths. Each timing path includes a first frequency divider 124 (DMC<sub>0</sub>–DMC<sub>3</sub>) for generating a respective analog master clock (AMC<sub>0</sub>–AMC<sub>3</sub>), a multiplexor (any of 126a–d) for directing the output of the first frequency divider, and a second frequency divider 128 (DA<sub>0</sub>–DA<sub>3</sub>), for generating a respective output clock (A<sub>0</sub>–A<sub>3</sub>). (designated as a0–a3 in the FIGS. 3 to 9). The output clocks A<sub>0</sub>–A<sub>3</sub> are transmitted over an instrument bus, where they are accessible for use by individual instruments.

The Catalyst clocking system employs an internal architecture (not shown) that enables it to operate as if the ORC was running at  $K * 100$  MHz. In its physical implementation, however, the reference clock remains fixed at 100 MHz. This detail is operationally transparent, however. Programming the digital clocks C0, T0 and the analog clocks A<sub>0</sub>–A<sub>3</sub> involves merely prescribing divider values for the first and second divider values for each respective timing path, as if the ORC were simply being divided by the divider values.

FIG. 2 illustrates a tester environment in which the invention may be used. A user 210, for example a test engineer, operates a workstation or other computer 212. The workstation 212 runs a computer program 213 for configuring clocks in a tester 220 and a test program 218. The tester 220 includes a clocking system 222, which corresponds to the clocking system 100 of FIG. 1. The tester 220 also includes digital I/O 224, for sourcing and sampling digital signals from a DUT 228 under control of clocks C0 or T0, and analog instruments 226, for sourcing and sampling analog signals under control of the analog clocks A<sub>0</sub>–A<sub>3</sub>.

The computer program 213, herein referred to as the “Clock Manager,” includes a graphical user interface (GUI) 214 that communicates with software 216. In the preferred embodiment, the Clock Manager is implemented on a PC-compatible computer or workstation using Microsoft® Visual Basic®. The GUI 214 includes fields and controls for receiving user input, displaying output, and receiving commands. The software 216 operates in response to input and commands to generate clocking configuration data. The clocking configuration data specifies how the clocking system (i.e., the dividers and K Multiplier) should be configured to meet the desired clock frequencies specified by the user.

The GUI 214 preferably includes forms with which the user can interact. FIG. 3 shows the Clock Manager Form 300, which is preferably displayed when the user first launches the Clock Manager program. The Clock Manager Form 300 presents the user with a graphical model of the test system’s clocking system. Within this model, a representation 310 of the 100 MHz reference appears to be frequency-multiplied by a modeled “K Multiplier” 312 to produce an ORC 314. The ORC 314 appears to branch into a digital section 316 and an analog section 318.

Within the digital section, fields 320 and 324 respectively correspond to the first and second frequency dividers 118 and 120 of the clocking system 100, and fields 322 and 326 respectively correspond to the frequencies of the digital clocks C0 and T0. Within the analog section, the ORC branches to four timing paths. Each timing path has fields for the first and second dividers, 328 and 332, which correspond respectively to dividers 124a–d and 128a–d of the clocking system 100. Each timing path also has fields 330 and 334 that correspond to the Analog Master Clock (AMC<sub>0</sub>–AMC<sub>3</sub>) and the Analog Clock (A<sub>0</sub>–A<sub>3</sub>), respectively.

The analog section 318 also includes radio buttons 336 and checkboxes 338 for designating how the AMC’s are to be distributed to second dividers 332 for generating the analog clocks a0–a3. These radio buttons and checkboxes represent the switching functions of multiplexors 126a–d of FIG. 1. By selecting a radio button 336 and checking any number of checkboxes 338, the user effectively “connects” the selected AMC to the input of the second divider 332 of each timing path whose checkbox is selected. Once established, connections remain in place, even when different radio buttons and checkboxes are selected. Newer connections overwrite older connections.

## 5

Inputs to the Clock Manager Form of FIG. 3 are designated as unshaded fields, and outputs are designated as shaded fields. To operate the Clock Manager Form 300, the user inputs desired clock frequencies to any of the fields for C0, T0, and A<sub>0</sub>-A<sub>3</sub> (fields 322, 326, and 334, respectively). The user then clicks either the "Find Dividers" button 352 or the "ORC Fixed Find" button 354. In response to either of these button clicks, the software 216 automatically calculates divider values for all dividers required to produce the clocks for which the user has entered desired frequencies. If the user clicks the "Find Dividers" button, the software 216 computes the divider values and K Multiplier for variable ORC mode. If the user clicks the "ORC Fixed Find" button, the software 216 computes the divider values for fixed ORC mode (i.e., K=500,000,000).

FIG. 4 shows the output of the Clock Manager Form 300 for variable ORC mode. The user has previously entered 100 MHz in the T0 field (326), 500 KHz in the A<sub>0</sub> field, and 150 KHz in the A<sub>1</sub> field (334). The user has then clicked the "Find Dividers" button 352. In response, the software 216 has computed and outputted values for the K Multiplier 312, the first and second dividers (for the digital clocks, A<sub>0</sub>, and A<sub>1</sub>), and C0 322 (C0 can be either an output or an input. If no input is prescribed, the software assumes J equals 1 and sets C0 equal to T0).

It is important to note that the software 216 has successfully determined values for the K Multiplier and dividers to provide the precise desired frequencies that the user has requested. Because the software was able to precisely hit the desired frequencies, the ratios between T0 and A<sub>0</sub>, T0 and A<sub>1</sub>, and A<sub>0</sub> and A<sub>1</sub> are precisely what the user prescribed. If these ratios are required for coherence, the ratios are preserved and coherence is assured.

FIG. 5 shows the output of the Clock Manager Form 300 for fixed ORC mode. The user has previously entered the same frequencies as in FIG. 4, but has clicked the "ORC Fixed Find" button 354. As before, the software 216 has computed and outputted values for the first and second dividers for T0, A<sub>0</sub>, and A<sub>1</sub>. The software has operated under the constraint that the K Multiplier be fixed at 500,000,000, however. This constraint limits the flexibility of the timing system and, in this case, has prevented the software from precisely hitting the target frequencies. Rather than abandoning its search or simply generating an error, the software 216 finds the frequencies closest to the desired target frequencies that meet the prescribed ratio. Since the ratio of the displayed frequencies for T0, A<sub>0</sub>, and A<sub>1</sub> are the same as the ratios of the originally prescribed target frequencies, coherence is still assured.

Note that the frequency error generated by fixed ORC mode is exceedingly small, less than 0.1 parts per million, in this case. This error is much smaller than other errors typically found in test systems, and can generally be ignored. The Clock Manager Program therefore enables the test engineer to derive coherent clocks for fixed ORC mode, without significantly sacrificing frequency accuracy. This is a great benefit to the test engineer, because fixed ORC mode is generally easier to use than variable ORC mode.

The operation of variable ORC mode and fixed ORC mode has been illustrated with only two target frequencies. More target frequencies can be prescribed, however, as testing needs require.

Certain tests do not require coherent clocks, or do not require that all the clocks prescribed for a test be coherent. Other tests require different sets of coherent clocks. Because coherence is a constraint that limits the software's ability to

## 6

hit the target frequencies (especially in fixed ORC mode), the GUI 214 preferably allows the user to remove the constraint if it is not required. By pressing the "Grouping" button 350, the GUI displays a Coherency Grouping Form 600 that allows the user to group different clocks together, or to separate clocks into different groups.

FIG. 6 shows the Coherency Grouping Form 600. A set 610 of radio buttons, numbered 1-5, is provided for C0/T0 and each of analog clocks shown on the Clock Manager Form (T0 and C0 are treated as one clock because they are inherently grouped together). The user assigns a clock to a group by clicking the radio button for a group number. Only one group number can be selected for each clock. The user assigns different clocks to the same group by giving them the same group number, or assigns different clocks to different groups by giving them different group numbers. Upon clicking the "Find Dividers" or "Fixed ORC Find" button, the software computes divider values (and K Multiplier, for variable ORC mode) that preserve the ratios of the desired frequencies within each group. The software does not necessarily preserve ratios among clocks assigned to different groups.

Coherency requires not only that inputted ratios among the clocks be preserved, but also that the ratios be correct. To this end, the Clock Manager Program includes an Instrument Form 700 for assisting the user in correctly prescribing coherent captures. The user invokes the Instrument Form 700 for a particular clock by clicking the Clock Assign Button 356 for that clock on the Clock Manager Form 300. A different Clock Assign Button is provided for each analog clock A<sub>0</sub>-A<sub>3</sub>.

FIG. 7 shows the Instrument Form 700. The Instrument Form 700 includes an aN Clock field 710, which specifies the frequency of the analog input clock (A<sub>0</sub>-A<sub>3</sub>). Label 712 indicates the number of the selected clock (here, "0" for clock a0). The user operates the Instrument Form 700 by first selecting an instrument from an Instrument Field 714, which is preferably implemented as a combo box. When the user clicks the Instrument Field, the field displays a list of all instruments that the form is capable of configuring. The user selects a desired instrument from the list, whereupon the Instrument Field displays the name of the selected instrument. The user can then specify timing characteristics for configuring the selected instrument.

Timing characteristics can be specific to each instrument type, but generally include sampling rate ( $F_s$ ), number of samples (N), frequency of interest ( $F_i$ ), and number of cycles (M) of the frequency of interest. These timing characteristics apply to both source and measure instruments. For an AWG, for example,  $F_s$  specifies the rate at which the AWG generates output samples, N specifies the number of samples generated,  $F_i$  specifies the output frequency, and M specifies the number of cycles generated at  $F_i$ . For a digitizer,  $F_s$  is the digitizer's sampling rate, N is the number of samples acquired during the sample window,  $F_i$  is the expected frequency to be measured, and M is the number of cycles at  $F_i$  that are completed during the sample window.

The Instrument Form 700 includes fields for each of  $F_s$ , N,  $F_i$ , and M (716, 718, 720, and 722, respectively). It also includes a field 724 for frequency resolution,  $F_{res}$ . Frequency resolution depends upon  $F_s$  and N, or, alternatively, on  $F_i$  and M, based on the equation  $F_{res} = F_s/N = F_i/M$ . For a digitizer,  $F_{res}$  represents the bin width of a DFT taken from its acquired samples. For an AWG,  $F_{res}$  represents the smallest frequency increment in which the AWG can be programmed. The Instrument Form 700 allows the user to

configure  $F_{res}$  separately because users often prefer to specify timing in terms of  $F_{res}$ .

The Instrument Form **700** presents the user with different fields when different instruments are selected, depending on the particular requirements of each instrument. For example, when the user selects the Precision Low-Frequency Source (PLFSRC), the Instrument Form presents only the fields described above (See FIG. 7). But when the user selects the Precision Low-Frequency Digitizer (PLFDIG), the Instrument Form displays two additional fields, one for multiplying aN Clock and one for dividing aN Clock to derive  $F_s$  (See FIG. 8).

Returning to FIG. 7, the Instrument Form **700** includes arrow buttons **734a–h** to assist the user in computing values for various fields. When the user clicks any of these arrow buttons **734a–h**, the software computes a value for the field the arrow button points to, based upon one or more of the other fields on the form. Clicking button **734c** computes  $F_{res}$  based upon previously entered values of  $F_s$  and  $N$  ( $F_{res}=F_s/N$ ). Conversely, clicking button **734e** computes  $F_s$  based on previously entered values of  $F_{res}$  and  $N$ . Clicking button **734d** finds the best value of  $N$ , given the previously entered values of  $F_s$  and  $F_{res}$ . If  $F_s/F_{res}$  is an integer, the software simply assigns  $N=F_s/F_{res}$ . If  $F_s/F_{res}$  is not an integer, the software works in one of two ways, depending on the state of checkbox **732**. If the checkbox **732** is checked, the software holds  $F_{res}$  constant in computing the best value of  $N$ . If the checkbox **732** is unchecked, the software holds  $F_s$  constant in computing  $N$ . In either case, the software selects the value of  $N$  that effects the smallest change in the timing characteristic that it is not instructed to hold constant— $F_s$  or  $F_{res}$ . Buttons **734f**, **g**, and **h** work analogously to buttons **734c**, **d**, and **e**, respectively, based on the constraint that  $F_{res}=F_i/M$ .

The Instrument Form **700** also includes a Calculate Button **742**. Clicking the Calculate Button directs the software to calculate  $F_{res}$ ,  $M$ , and  $N$ , based on previously entered values of  $F_s$  and  $F_i$ . Given the equation  $F_s/F_i=N/M$ , the software first attempts to calculate  $N$  and  $M$  by reducing the fraction  $F_s/F_i$  to simplest terms. The software assigns the numerator of the reduced fraction to  $N$ , and the denominator to  $M$ .  $F_{res}$  is then computed as  $F_s * N$ . If  $N$  is larger than allowed (i.e., the inputted values require that the instrument take too many samples), the software successively shifts  $F_i$  by small increments in search of the smallest integer values of  $N$  and  $M$  that place  $M$  and  $N$  within the allowable range. The resulting mismatch between the entered  $F_i$  and actual  $F_i$  is generally exceedingly small.

By clicking the arrow button **734a** on the Instrument Form, the GUI transfers the value of  $F_s$  to the aN Clock Field **710**. The user can close the Instrument Form **700** by clicking the Cancel Button **746** or the Return Button **744**. Clicking the Cancel Button **746** aborts the Instrument Form and returns control to the Clock Manager Form **300**. Clicking the Return Button **744** stores the state of the Instrument Form **700** and closes the form. It also sends the contents of the aN Clock Field **710** to the Analog Clock Field **344** of the Clock Manager Form **300** for the selected clock, i.e., the clock  $A_0$ – $A_3$  for which the user originally clicked the Clock Assign Button **356**.

As indicated above, instrument configurations are inherently subject to the constraint that  $F_s/N=F_i/M$ . We can rewrite this equation in the form  $F_s/F_i=M/N$ , whereupon it becomes clear that the fraction  $M/N$  must be reduced to simplest terms to prevent the instrument from generating or acquiring redundant data. To avoid redundant data, the

Instrument Form **700** includes an “N & M” status indicator **738**. The indicator turns green when  $M/N$  is in simplest terms (i.e.,  $M$  and  $N$  are mutually prime); otherwise, the indicator turns red.

The Instrument Form **700** also includes a Valid Indicator **736** and a Diagnostic Field **740**. Instrument capabilities constrain the flexibility with which timing characteristics can be configured. For instance, an AWG is designed to operate over only a limited range of sampling rates and to receive input signals over only a limited bandwidth. The software includes an Instrument Database to ensure that the inputted timing characteristics for each instrument accord with the instrument’s capabilities. The Instrument Database stores programming constraints for each instrument that is configurable using the Instrument Form **700**. In response to the user entering data in any of the timing fields (e.g., fields **716–724**), the software runs a validation routine. The validation routine compares the inputted timing characteristics with the stored programming constraints in the Instrument Database. If the inputted timing characteristics violate any of the instrument’s programming constraints, the Valid Indicator **736** turns red and a diagnostic message is displayed in the Diagnostic Field **740**. The diagnostic message generally identifies the violating timing characteristic and specifies an allowable range over which the timing characteristic can be programmed (See FIG. 8). Sometimes, an instrument configuration is invalid because certain combinations of timing characteristics are incompatible. In these cases, the diagnostic message preferably includes suggestions for modifying the timing characteristics. If the inputted timing characteristics do not violate any of the programming constraints stored in the Instrument Database, the Valid Indicator **736** turns green and the Diagnostic Field **740** is cleared.

As discussed above, coherence generally requires coordination among different clocks in a tester. Consider the case where a tester measures the gain of an amplifier at a particular frequency. An AWG applies a stimulus having frequency  $F_i$  to the input of the amplifier, and a digitizer captures an amplified response from the amplifier’s output. Since the amplifier’s output frequency is also  $F_i$ , the digitizer must sample the DUT’s response over a sample window that includes an integer number of cycles of  $F_i$ . In this case, therefore,  $F_i$  of the digitizer must equal  $F_i$  of the AWG to ensure coherence.

The Instrument Form **700** simplifies the task of ensuring coherence by allowing the user to configure one instrument’s timing characteristics as a function of another instrument’s timing characteristics. Clicking buttons **726**, **728**, and **730** on the Instrument Form causes the form to display additional fields for configuring timing dependencies for  $F_s$ ,  $F_i$ , and  $F_{res}$ , respectively.

FIG. 9 shows the Instrument Form **700** after the user has clicked the button **728**, for  $F_i$  dependence. As shown in FIG. 9, the Instrument Form displays a calculator region **900**, which was previously hidden. The calculator region **900** includes a numerator field **910** and a denominator field **912**. It also includes an analog branch region **914**, a source region **916**, and a Get Value button **918**. The user specifies a clock dependency for  $F_i$  by entering a numerator and a denominator in fields **910** and **912**, selecting a clock from the analog branch region **914**, and choosing one of the timing characteristics for the selected clock from the source region **916**. Regions **914** and **916** include radio buttons that allow only one item to be selected from each region. The settings displayed in the example of FIG. 9 correspond to an  $F_i$  frequency that equals 3/2 the  $F_s$  frequency specified for analog clock a1. As shown in the calculator region **900**,  $F_i$

can be configured based on any of the other clocks in the system, for of the timing characteristics shown. The user can click the Get Value button **918** once the user has set the fields **910**, **912**, **914**, and **916**. Clicking this button computes a value for  $F_i$  based on the entered settings and returns the computed value to the  $F_i$  field **722**.

The contents of the calculator region **900** are substantially identical regardless of which of the buttons **726**, **728**, or **730** has been clicked, with the exception that the title of the calculator region is changed based on the button pressed. The title reads, “ $F_s$  Dependence” when button **726** is clicked, “ $F_i$  Dependence” when button **728** is clicked, and “ $F_{res}$  Dependence” when the button **730** is clicked.

FIGS. **10** and **11** show examples of algorithms according to the invention for configuring a tester’s clocking system for variable ORC mode (FIG. **10**) and fixed ORC mode (FIG. **11**). Preferably, the algorithms are executed by the software **216**, which operates in response to user input and commands from the GUI **214**. The software **216** preferably executes one of these algorithms whenever the user has entered desired frequencies in the Clock Manager Form **300** and has clicked either the Find Dividers button **352** or the ORC Fixed Find button **354**. Referring briefly to FIG. **1**, we first recognize that the elements of the clocking system **100** are mathematically related as follows:

$$C0 * D = ORC; \quad (1)$$

$$A_L * DA_L * DMC_L = ORC; \quad L=0, 1, 2, \text{ and } 3; \text{ and} \quad (2)$$

$$100 \text{ MHz} * K = ORC. \quad (3)$$

To realize the desired frequencies using frequency dividers (e.g., counters), we search for a solution set for which K and each of the following dividers is an integer: D,  $DA_L$ , and  $DMC_L$ ;  $L=0, 1, 2, \text{ and } 3$ .

Referring first to FIG. **10**, the algorithm for variable ORC mode first seeks to determine the least common multiple (LCM) of the desired frequencies and the frequency of the master clock, i.e., the LCM of  $A_0$ – $A_3$ , C0, and 100 MHz (step **1010**). If the user has entered fewer desired frequencies in the fields of the Clock Manager Form, step **1010** ignores the blank fields and finds the LCM of only the fields for which the user has entered desired frequencies. The resulting LCM is the smallest number into which each of the desired frequencies and the master clock can be evenly divided. Being divisible in this way means that counters or other integer-based dividers can be used to generate each desired frequency from the ORC. It also means that K can be realized as an integer to generate the ORC from the master clock.

It is significant that the LCM is the “least” common multiple, rather than some other common multiple, of the desired frequencies and the master clock. Making the LCM the “least” common multiple maximizes the flexibility with which the algorithm can distribute divisions among different tiers of dividers in the clocking system (i.e., first dividers **124** and second dividers **128**). This is important because the Analog Master Clocks ( $AMC_0$ – $AMC_3$ ) in the Catalyst test system have an upper and a lower frequency limit. Therefore, the second dividers **128** ( $DA_L$ ) must be chosen so that the desired frequencies  $F_{DES-L}$  times the second dividers  $DA_L$  fall within the allowable range of the AMCs. In addition, if the LCM is greater than the maximum allowable ORC ( $2^{29}$ ), no solution will enable the clocking system to precisely produce the desired frequencies. Finding the “least” common multiple thus affords the algorithm its highest probability for success.

At step **1012**, the algorithm determines the values of the  $DA_L$  dividers **128**. This step operates under two constraints. First, the product of each  $DA_L * F_{DES-L}$  must fall within the allowable range of the respective AMC. Second, the value of  $DA_L$  should preferably add as few factors as possible (ideally none) to the LCM. This means that, to as great an extent as possible, the factors of the  $DA_L$  dividers should be a subset of the factors of the LCM. As before, minimizing factors promotes greater flexibility in configuring the clocking system and improves the chances of attaining a successful setup.

Steps **1012a**–**1012c** expand the detail of step **1012**. For each analog timing path, the algorithm computes a lower limit (LL) and an upper limit (UL) of  $DA_L$  that places  $AMC_L$  within its allowable range. Thus,

$$LL = AMC_{MIN} / F_{DES-L}, \text{ and} \quad (4)$$

$$UL = AMC_{MAX} / F_{DES-L}. \quad (5)$$

To ensure that LL and UL are within range, LL is rounded up and UL is rounded down. The algorithm then examines each integer from LL to UL and determines its factors. If an integer is found that adds no new factors to the LCM, the algorithm assigns  $DA_L$  the value of that integer and stops searching. Otherwise, the algorithm assigns  $DA_L$  the value of the integer that adds the fewest additional factors to the LCM. This process is repeated for each analog timing path.

At step **1014**, the algorithm calculates each  $AMC_L$  as  $F_{DES-L} * DA_L$ . The algorithm also computes an updated LCM, called “LumpLCM,” which includes all the factors of the original LCM, plus any additional factors that were needed to realize the  $DA_L$  dividers.

At step **1016**, the algorithm finds for another integer, “p,” such that the product  $p * LumpLCM$  falls within the allowable range of the ORC, here  $2^{28}$ – $2^{29}$ . Given this constraint, p can be any integer between  $ORC_{MIN} / LumpLCM$  and  $ORC_{MAX} / LumpLCM$ . The middle value of p within this range is used for subsequent processing; however, the choice of p is arbitrarily and any of the values that fall within the designated range can be used.

Once p is known, the remaining clock settings fall into place (step **1018**). In particular,

$$ORC = p * LumpLCM; \quad (6)$$

$$K = ORC / 100 \text{ MHz}; \quad (7)$$

$$D = ORC / C0; \text{ and} \quad (8)$$

$$DMC_L = ORC / AMC_L. \quad (9)$$

At the conclusion of step **1018**, the algorithm has finished computing clocking configuration data for variable ORC mode. The algorithm has either precisely hit the desired frequencies, or the setup has failed because the LumpLCM is larger than the greatest allowable ORC.

In variable ORC mode, coherency grouping need not be considered because the flexibility of varying the ORC obviates the need for rounding. Since frequencies are not rounded, frequency ratios are preserved across all clocks, whether coherence is required or not. Referring now to FIG. **11**, the first four steps **1110**–**1114** for fixed ORC mode are closely related to steps **1010**–**1014** of FIG. **10**. At step **1110**, the algorithm seeks as before to find the least common multiple (LCM) of the desired frequencies and the frequency of the master clock, i.e., the LCM of  $A_0$ – $A_3$ , C0, and 100 MHz. At step **1111**, however, the algorithm also seeks to find a larger least common multiple, “BigLCM,” of the desired

frequencies and the ORC, i.e., the LCM of  $A_0$ – $A_3$ ,  $C_0$ , and 50,000 THz. BigLCM is then used at step **1112**, wherein the second dividers are chosen to minimize new factors beyond those already included in BigLCM. The factors of BigLCM are relevant, instead of those of LCM, to allow the algorithm to find, whenever possible, divider values that exactly produce the desired frequencies (i.e., without rounding—see below). Note that BigLCM is used only for minimizing new factors in step **1012**. Once the new factors, if any, are determined, the algorithm calculates LumpLCM as the product of LCM any additional factors needed to realize the second dividers.

At step **1114**, the algorithm computes the AMCs as using the second dividers determined at step **1112**. The actions performed at this step are substantially identical to those performed at step **1012** in FIG. **10**.

Proceeding now to step **1116**, the algorithm computes a value  $n = \text{ORC}_{\text{FIXED}} / \text{LumpLCM}$ , where  $\text{ORC}_{\text{FIXED}}$  is nominally 50,000 THz. Because  $n$  is not necessarily an integer, the algorithm preferably rounds  $n$  to the nearest integer  $n_r$  to ensure that the clocking system can be configured with counters or other integer-based dividers. At step **1118**, the algorithm computes the DMC dividers **124a–d** and the D divider **118** as follows:

$$\text{DMC}_L = n_r * \text{LumpLCM} / \text{AMC}_L; L=0, 1, 2, \text{ and } 3; \text{ and} \quad (10)$$

$$D = n_r * \text{LumpLCM} / C_0. \quad (11)$$

If  $n$  was not originally an integer, then rounding  $n$  to produce  $n_r$  produces a rounding error,  $n_r/n$ , which affects the AMCs and the desired frequencies. At step **1120**, the algorithm accounts for this rounding error in computing the actual frequencies as follows:

$$\text{AMC}_L = \text{ORC}_{\text{FIXED}} / \text{DMC}_L; L=0, 1, 2, \text{ and } 3; \quad (12)$$

$$F_{\text{DES-}L} = \text{AMC}_L / \text{DA}_L; L=0, 1, 2, \text{ and } 3; \text{ and} \quad (13)$$

$$C_0 = \text{ORC}_{\text{FIXED}} / D. \quad (14)$$

At the conclusion of step **1120**, the algorithm has finished computing clocking configuration data for fixed ORC mode.

Note that each of the desired frequencies and  $C_0$  is askew from its originally prescribed value by a factor  $n_r/n$  (assuming  $n_r \neq n$ ). Because this factor is present in all frequencies that the clocking system produces, ratios among different frequencies are retained. Therefore, coherence is assured, despite the fact that precise target frequencies can not always be attained.

Frequency errors produced by this technique are exceedingly small. The emphasis on minimizing the number of factors in LumpLCM generally ensures that  $n$  is a large number. Therefore, the factor  $n_r/n$  is generally close to 1, ensuring that actual frequencies are very close to their originally prescribed values. Because LumpLCM is minimized, the algorithm minimizes frequency errors to the theoretically lowest values that the clocking system can achieve, while still ensuring coherence. These frequency errors are often smaller than other timing errors commonly found in test systems—so small, in fact, that they can generally be ignored.

Coherency grouping is significant for fixed ORC mode, because rounding errors distort frequency values. For fixed ORC mode, the algorithm simply treats different coherency groups as if they belonged to different clocking systems. Different groups are thus allowed have different LumpLCMs and different values of  $n$ . It may be necessary to round  $n$  for some groups but not for others. Therefore, some groups may have frequency errors, while others may not.

The foregoing description assumes that each of the multiplexors **126a–126d** passes the AMC for its respective timing path to its output, i.e., multiplexor **126a** passes  $\text{AMC}_0$ , multiplexor **126b** passes  $\text{AMC}_1$ , and so on. As indicated above, however, the system for configuring clocks is not limited to this arrangement. In the preferred embodiment, the algorithm accounts for switching by computing divider values based on actual connections.

The system herein described greatly simplifies the task of configuring multiple clocks in a test system. It automatically generates clocking configuration data based on user-specified frequencies, and guides users to specify valid configurations by checking inputs against clocking system and instrument capabilities. The system is also expandable. The system can accommodate new instruments through updates to the Instrument Form **700** and instrument database. In addition, the algorithm can easily handle additional clocks because the time needed to execute the algorithm scales linearly with the number of clocks.

#### 20 Alternatives

Having described one embodiment, numerous alternative embodiments or variations can be made. For example, the Clock Manager program has been described herein in connection with the Catalyst test system. The invention is not limited to use with this test system, however. It can be used with any test system having a reference clock, any number of clocks derived therefrom using frequency dividers and/or multipliers.

The embodiment described herein includes two tiers of frequency dividers, e.g., a first tier including dividers **128** and a second tier including dividers **124**. It is apparent from the foregoing, however, that the algorithm is scalable for use with clocking systems having greater than two tiers of dividers. In particular, the algorithm could be scaled by repeating steps **1012** and **1014** (or steps **1112** and **1114**) for each successive tier. Values for each successive tier of dividers would be chosen to meet frequency range requirements, as well as to add as few factors as possible to LCM.

The foregoing description employs mathematical expressions for conveying an understanding of the underlying algorithm. The algorithm should not be limited to these particular expressions, however. As known to those skilled in the art, mathematics provides great flexibility in expressing quantitative concepts in a wide variety of forms. The invention should therefore be construed as encompassing algorithms achieving substantially the same result using a wide variety of substantially equivalent mathematical forms.

As described herein, the system for configuring clocks is implemented as a Visual Basic® program running on a PC-compatible computer. The invention is not limited to this implementation, however. As known to those skilled in the art, many different software and hardware environments can be used to implement the system according to the invention.

The system for configuring clocks need not be provided as a single computer program, per se. It can be packaged in a myriad of ways, such as with different software modules, software libraries, or computer programs that communicate with one another. Moreover, the interface for communicating with the system need not necessarily be a GUI. It can instead be a software interface for communicating with other software components.

The system for configuring clocks need not necessarily be run on a tester. It can also be run on a development station or on any computer on which test programs are developed, debugged, or examined. It can also be used for demonstration or training purposes.



In addition to generating configuration data, the system for configuring clocks can also be used to program a tester's clocking system directly. For example, the GUI of the Clock Manager can include an additional control that, when activated, causes the software to set up the tester according to the clocking configuration data. The clocks could thus be run in a "live" mode to examine or troubleshoot particular test scenarios. As yet another alternative, the GUI can include a control for generating test program code. When activated, the control causes the software to generate test program code for inclusion in a test program. The test program code can be in the native language of the tester, or in a universal testing language that is later translatable into tester-specific code. When the test program is later run, the program code will configure the tester in accordance with the clocking configuration data to establish the desired configuration.

Each of these alternatives and variations, as well as others, has been contemplated by the inventors and is intended to fall within the scope of the instant invention. It should be understood, therefore, that the foregoing description is by way of example, and the

What is claimed is:

1. A system for configuring an automatic test system comprising:

an interface comprising inputs for specifying desired frequencies of clocks and inputs for specifying timing characteristics of instruments of the automatic test system;

software, operative in response to the interface, for calculating values of dividers, for establishing the desired frequencies of the clocks; and

error checking code for comparing the specified timing characteristics of the instruments with stored data indicative of capabilities of the instruments.

2. A system as recited in claim 1, wherein the interface comprises an input for specifying the frequency of at least one of the clocks as a function of at least one other of the clocks.

3. A system as recited in claim 1, wherein the interface further includes a window for displaying error messages generated by the error checking code in response to the specified timing characteristics being incompatible with the capabilities of the instruments.

4. A system as recited in claim 1, further comprising code for calculating the desired frequency of at least one of the clocks in response to the inputted timing characteristics of the instruments.

5. A system as recited in claim 1, wherein the software produces output indicative of the calculated values of the dividers, and

the interface further comprises a display of the calculated values of the dividers.

6. A system as recited in claim 5, wherein the interface further comprises a display of prime factors of the calculated values of the dividers.

7. A system as recited in claim 1, wherein the interface further comprises inputs for assigning different ones of the clocks to groups within which coherency must be maintained.

8. A method for configuring an automatic test system comprising:

receiving a plurality of inputs specifying desired frequencies of clocks;

calculating, in response to the received inputs, values of dividers coupled to the reference clock, for establishing the desired frequencies of the clocks;

specifying timing characteristics of an instrument of the test system; and

comparing the specified timing characteristics for the instrument with stored data indicative of capabilities of the instrument.

9. A method as recited in claim 8, further comprising specifying the desired frequency of at least one of the clocks as a function of at least one other of the clocks.

10. A method as recited in claim 8, wherein the timing characteristics include any of an instrument's sampling rate, frequency of interest, frequency divider values, frequency multiplier values, and frequency resolution.

11. A method as recited in claim 10, wherein specifying timing characteristics comprises specifying instrument's sampling rate as a function of a timing characteristic of another instrument.

12. A method as recited in claim 10, wherein specifying timing characteristics comprises specifying an instrument's frequency of interest as a function of a timing characteristic of another instrument.

13. A method as recited in claim 10, wherein specifying timing characteristics comprises specifying an instrument's frequency resolution as a function of a timing characteristic of another instrument.

14. A method as recited in claim 10, further comprising calculating a desired clock frequency for driving an instrument based upon the timing characteristics for the instrument.

15. A method as recited in claim 8, further comprising displaying error messages generated by the comparing step, in response to the specified timing characteristics being incompatible with the capabilities of the instrument.

16. A method as recited in claim 8, further comprising displaying output indicative of calculated values of the dividers.

17. A method as recited in claim 16, further comprising displaying prime factors of the calculated values of the dividers.

18. A method as recited in claim 8, wherein desired clock frequencies are related by ratios that ensure coherent testing, and further comprising modifying the desired clock frequencies to precisely maintain the ratios, in instances wherein the test system cannot meet the inputted ratios at the desired frequencies.

19. A method as recited in claim 18, further comprising: assigning different ones of the clocks to groups, and modifying the desired frequencies of clocks assigned to the same group to precisely maintain the inputted ratios between clock frequencies in the same group.

20. A method as recited in claim 8, wherein receiving comprises receiving an input for each of the desired frequencies in the form of a rational numerator divided by a rational denominator.

21. A method as recited in claim 8, further comprising generating test program code for programming the dividers within the automatic test system to assume the calculated values.

22. A method as recited in claim 21, further comprising storing the test program code in a test program for running on the automatic test system.

23. A system for configuring an automatic test system, comprising:

an interface comprising inputs for specifying desired frequencies of clocks and inputs for specifying timing characteristics of instruments of the automatic test system;

software, operative in response to the interface, for calculating values of dividers, for establishing the desired frequencies of the clocks; and

**15**

code for calculating the desired frequency of at least one of the clocks in response to the inputted timing characteristics of the instruments.

**24.** The system of claim **23** wherein the interface comprises an input for specifying the frequency of at least one of the clocks as a function of at least one other of the clocks.

**25.** A system as recited in claim **23** wherein the interface further comprises inputs for assigning different ones of the clocks to groups within which coherency must be maintained.

**26.** A system for configuring an automatic test system, comprising:

an interface comprising inputs for specifying desired frequencies of clocks and inputs for specifying timing characteristics of instruments of the automatic test system;

**16**

software, operative in response to the interface, for calculating values of dividers, for establishing the desired frequencies of the clocks, the software producing output indicative of the calculated values of the dividers,

wherein the interface further comprises a display of the calculated values of the dividers and a display of prime factors of the calculated values of the dividers.

**27.** The system of claim **26** wherein the interface comprises an input for specifying the frequency of at least one of the clocks as a function of at least one other of the clocks.

**28.** A system as recited in claim **26**, wherein the interface further comprises inputs for assigning different ones of the clocks to groups within which coherency must be maintained.

\* \* \* \* \*