

US007048752B2

(12) **United States Patent**  
**Mazzocchi et al.**

(10) **Patent No.:** **US 7,048,752 B2**  
(45) **Date of Patent:** **May 23, 2006**

(54) **METHOD AND DEVICE FOR FILTERING BODY FLUID**

(75) Inventors: **Rudy Mazzocchi**, Woodbury, MN (US);  
**Timothy Claude**, Coon Rapids, MN (US); **James Segermark**, Gem Lake, MN (US)

(73) Assignee: **ev3 Inc.**, Plymouth, MN (US)

(\*) Notice: Subject to any disclaimer, the term of this patent is extended or adjusted under 35 U.S.C. 154(b) by 340 days.

(21) Appl. No.: **10/051,648**

(22) Filed: **Jan. 18, 2002**

(65) **Prior Publication Data**

US 2002/0095173 A1 Jul. 18, 2002

**Related U.S. Application Data**

(63) Continuation of application No. 08/748,066, filed on Nov. 12, 1996, now Pat. No. 6,605,102, which is a continuation of application No. 08/272,425, filed on Jul. 8, 1994, now abandoned.

(51) **Int. Cl.**  
**A61M 29/00** (2006.01)

(52) **U.S. Cl.** ..... **606/200**

(58) **Field of Classification Search** ..... 606/200,  
606/108, 110, 159, 191, 194, 195, 127, 128;  
604/22, 101.01  
See application file for complete search history.

(56) **References Cited**

**U.S. PATENT DOCUMENTS**

2,281,448 A	4/1942	Mathey
3,334,629 A	8/1967	Cohn
3,540,431 A	11/1970	Mobin-Uddin
3,868,956 A	3/1975	Alfidi et al.

(Continued)

**FOREIGN PATENT DOCUMENTS**

DE	28 21 048 B1	11/1979
DE	31 07 392 A1	9/1982
DE	233 303	2/1986
EP	0 380 666	4/1989

(Continued)

**OTHER PUBLICATIONS**

Aug. 8, 2005 Minutes of the oral proceedings before the Opposition Division regarding EP 0 769 926 B1 (6 pages).  
 Aug. 8, 2005 Interlocutory decision in Opposition proceedings regarding EP 0 769 926 B1 (46 pages).  
 English language translation of DE-A-3107392 (15 pages).  
 EPO Communication in counterpart foreign application 02076318.1 dated Nov. 25, 2004 (2 pages) (citing DE 31 07 392 A1).  
 Search Report for Counterpart European Application EP 0 207 6318.  
 English Language Abstract for FR 2,500,756.  
 Claims for U.S. Appl. No. 08/748,066, filed Nov. 12, 1996 (Ref. No. MVA1001USC1).  
 Claims for U.S. Appl. No. 10/051,565, filed Jan. 18, 2002 (Ref. No. MVA1001USC2).  
 Claims for U.S. Appl. No. 10/051,492, filed Jan. 18, 2002 (Ref. No. MVA1001USC3).  
 Claims for U.S. Appl. No. 10/051,591, filed Jan. 18, 2002 (Ref. No. MVA1001USC4).

(Continued)

*Primary Examiner*—Vy Bui  
 (74) *Attorney, Agent, or Firm*—Popvich, Wiles & O'Connell, P.A.

(57) **ABSTRACT**

Medical devices for filtering fluids flowing through a lumen and a method of forming medical devices. The devices can be used in vascular channels, urinary tracts, biliary ducts and the like, and filter emboli and other debris generated at a treatment site.

**53 Claims, 17 Drawing Sheets**

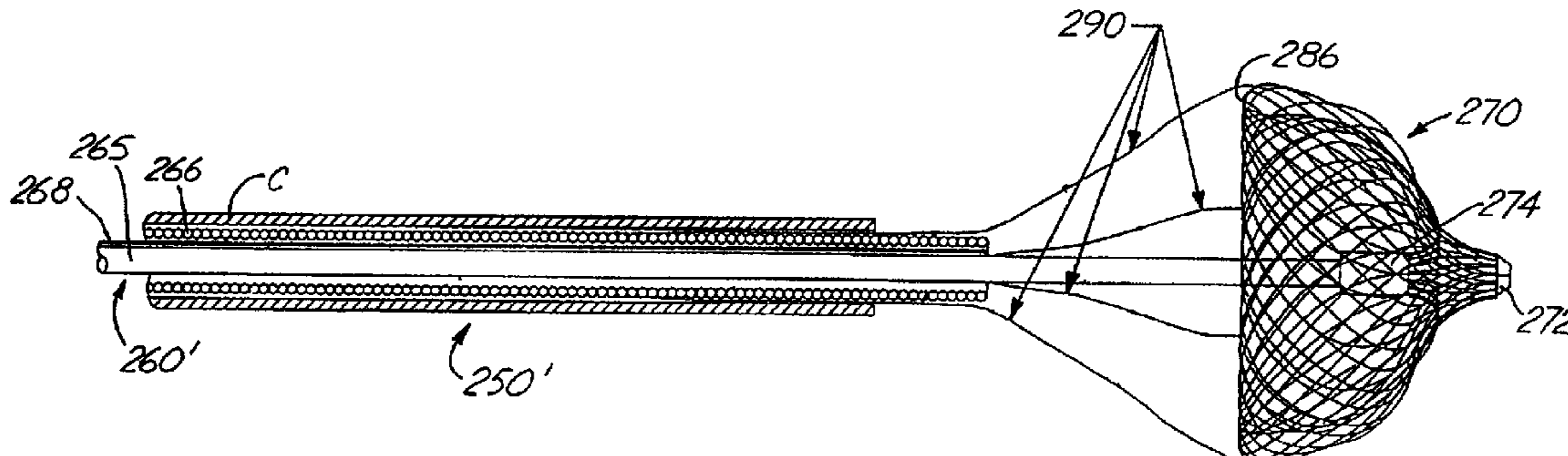

U.S. PATENT DOCUMENTS

3,952,747 A 4/1976 Kimmell, Jr.  
 3,996,938 A 12/1976 Clark, III  
 4,425,908 A 1/1984 Simon  
 4,494,531 A 1/1985 Gianturco  
 4,503,569 A 3/1985 Dotter  
 4,553,545 A 11/1985 Maass et al.  
 4,572,186 A 2/1986 Gould et al.  
 4,611,594 A 9/1986 Grayhack et al.  
 4,619,246 A 10/1986 Molgaard-Nielsen et al.  
 4,631,052 A 12/1986 Kensey  
 4,643,184 A 2/1987 Mobin-Uddin  
 4,649,922 A 3/1987 Wiktor  
 4,650,466 A 3/1987 Luther  
 4,655,771 A 4/1987 Wallsten  
 4,655,772 A 4/1987 De Liotta et al.  
 4,665,906 A 5/1987 Jervis  
 4,669,469 A 6/1987 Gifford, III et al.  
 4,681,110 A 7/1987 Wiktor  
 4,690,684 A 9/1987 McGreevy et al.  
 4,699,611 A 10/1987 Bowden  
 4,723,549 A 2/1988 Wholey et al.  
 4,727,873 A 3/1988 Mobin-Uddin  
 4,728,319 A 3/1988 Masch  
 4,732,152 A 3/1988 Wallsten et al.  
 4,733,665 A 3/1988 Palmaz  
 4,790,812 A 12/1988 Hawkins, Jr. et al.  
 4,790,813 A 12/1988 Kensey  
 4,793,348 A 12/1988 Palmaz  
 4,794,928 A 1/1989 Kletschka  
 4,800,882 A 1/1989 Gianturco  
 4,807,626 A 2/1989 McGirr  
 4,817,600 A 4/1989 Herms et al.  
 4,830,003 A 5/1989 Wolff et al.  
 4,832,055 A 5/1989 Palestrant  
 4,842,579 A 6/1989 Shiber  
 4,848,343 A 7/1989 Wallsten et al.  
 4,856,516 A 8/1989 Hillstead  
 4,873,978 A 10/1989 Ginsburg  
 4,886,062 A 12/1989 Wiktor  
 4,921,484 A 5/1990 Hillstead  
 4,926,858 A 5/1990 Gifford, III et al.  
 4,927,426 A 5/1990 Dretler  
 4,935,068 A 6/1990 Duerig  
 4,957,482 A 9/1990 Shiber  
 4,969,891 A 11/1990 Gewertz  
 4,984,581 A 1/1991 Stice  
 4,990,156 A 2/1991 Lefebvre  
 4,991,602 A 2/1991 Amplatz et al.  
 4,998,539 A 3/1991 Delsanti  
 5,002,560 A 3/1991 Machold et al.  
 5,011,488 A 4/1991 Ginsburg  
 5,016,808 A 5/1991 Heil, Jr. et al.  
 5,026,377 A 6/1991 Burton et al.  
 5,034,001 A 7/1991 Garrison et al.  
 5,041,093 A 8/1991 Chu  
 5,053,008 A 10/1991 Bajaj  
 5,059,205 A 10/1991 El-Nounou et al.  
 5,064,435 A 11/1991 Porter  
 5,067,489 A 11/1991 Lind  
 5,067,957 A 11/1991 Jervis  
 5,071,407 A 12/1991 Termin et al.  
 5,098,441 A 3/1992 Wechler  
 5,098,776 A 3/1992 Kobayashi et al.  
 5,100,423 A 3/1992 Fearnot  
 5,100,425 A 3/1992 Fischell et al.  
 5,102,415 A 4/1992 Guenther et al.  
 5,108,418 A 4/1992 Lefebvre  
 5,108,419 A 4/1992 Reger et al.  
 5,133,733 A 7/1992 Rasmussen et al.  
 5,135,531 A 8/1992 Shiber

5,152,777 A 10/1992 Goldberg et al.  
 5,160,342 A 11/1992 Reger et al.  
 5,190,546 A 3/1993 Jervis  
 5,192,286 A 3/1993 Phan et al.  
 5,192,301 A 3/1993 Kamiya et al.  
 5,195,955 A 3/1993 Don Michael  
 5,221,261 A 6/1993 Termin et al.  
 5,246,445 A 9/1993 Yachia et al.  
 5,256,146 A 10/1993 Ensminger et al.  
 5,329,942 A 7/1994 Gunther et al.  
 5,334,217 A 8/1994 Das  
 5,354,310 A 10/1994 Garnic et al.  
 5,382,259 A 1/1995 Phelps  
 5,383,887 A 1/1995 Nadal  
 5,383,892 A 1/1995 Cardon et al.  
 5,385,329 A 1/1995 Phillips et al.  
 5,415,630 A 5/1995 Gory et al.  
 5,417,708 A 5/1995 Hall et al.  
 5,421,955 A 6/1995 Lau et al.  
 5,423,742 A 6/1995 Theron  
 5,462,529 A 10/1995 Simpson  
 5,514,115 A 5/1996 Frantzen et al.  
 5,527,338 A 6/1996 Purdy  
 5,540,707 A 7/1996 Ressemann et al.  
 5,556,389 A 9/1996 Liprie  
 5,597,378 A 1/1997 Jervis  
 5,662,671 A 9/1997 Barbut et al.  
 5,690,671 A 11/1997 McGurk et al.  
 5,814,064 A 9/1998 Daniel  
 6,325,815 B1 12/2001 Kusleika  
 6,371,971 B1 4/2002 Tsugita et al.  
 2001/0012951 A1 8/2001 Bates et al.  
 2001/0041908 A1 11/2001 Levinson et al.

FOREIGN PATENT DOCUMENTS

EP 0 391 384 B1 10/1990  
 EP 0 547 530 6/1993  
 EP 820729 1/1998  
 EP 0 769 926 B1 1/2003  
 FR 2500756 9/1982  
 FR 2 527 301 11/1983  
 FR 2 641 692 7/1990  
 GB 2 020 557 11/1979  
 JP 44 20599 9/1969  
 JP 54 150 888 11/1979  
 WO WO 92/15357 9/1992  
 WO 93/10714 6/1993  
 WO WO 93/12723 7/1993  
 WO 94/05372 3/1994  
 WO WO 94/06372 3/1994  
 WO WO 96/01591 1/1996  
 WO WO 96/01599 1/1996  
 WO WO 98/39053 9/1998  
 WO WO 99/23976 5/1999  
 WO WO 01/15629 3/2001  
 WO WO 01/21100 3/2001

OTHER PUBLICATIONS

Claims for U.S. Appl. No. 10/051,537, filed Jan. 18, 2002 (Ref. No. MVA1001USC5).  
 Claims for U.S. Appl. No. 10/060,272, filed Jan. 30, 2002 (Ref. No. MVA1001USC7).  
 Claims for U.S. Appl. No. 10/060,271, filed Jan. 30, 2002 (Ref. No. MVA1002USC1).  
 Claims for U.S. Appl. No. 09/824,910, filed Apr. 3, 2001 (Ref. No. MVA1004USC1).  
 Claims for U.S. Appl. No. 10/060,854, filed Jan. 30, 2002 (Ref. No. MVA1004USC2).

- U.S. Appl. No. 10/093,572, filed Mar. 8, 2002 (Ref. No. MVA1003US).
- U.S. Appl. No. 10/132,562, filed Apr. 25, 2002 (Ref. No. MVA1005US).
- U.S. Appl. No. 10/194,355, filed Jul. 12, 2002 (Ref. No. MVA1007US).
- U.S. Appl. No. 10/194,734, filed Jul. 12, 2002 (Ref. No. MVA1008US).
- U.S. Appl. No. 10/096,624, filed Mar. 12, 2002 (Ref. No. F&B file).
- English language abstract for DE2821048.
- Castaneda, et al., Migration of a Kimray–Greenfield Filter to the Right Ventricle, *Radiology*, Dec. 1983, pp. 687–690.
- Allison, et al., article entitled: Therapeutic Embolization, *British Journal of Hospital Medicine*, Dec. 1978.
- Palestrant, et al. article entitled: Comparative In Vitro Evaluation of the Nitinol Inferior Vena Cava Filter, pp. 351–355.
- Duerig, et al., Superelastic Nitinol for Medical Devices, *Medical Plastics and Biomaterials*, Mar./Apr. 1997, pp. 30–43.
- Dotter et al., “Transluminal Expandable Nitinol Coil Stent Grafting: Preliminary Report”, *Radiology* 147:259–260, Apr. 1983.
- Schatz, et al., “Balloon–expandable intracoronary stents in the adult dog”, *Circulation*, vol. 76, No. 2, Aug. 1987:450–457.
- Palmaz, et al. “Atherosclerotic Rabbit Aortas: Expandable Intraluminal Grafting”, *Radiology* 1986; 160:723–726.
- Rosseau et al., “Self–expanding Endovascular Prosthesis: An Experimental Study”, *Radiology* 1987; 164:709–714.
- Duprat, Jr. et al., “Self–expanding Metallic Stents for Small Vessels: An Experimental Study”, *Radiology* 1987; 162:469–472.
- Sweden Now, “When hope is all in vein”, 1988.
- Dotter, “Transluminally–placed Coilspring Endarterial Tube Grafts, Long–term Patency in Canine Popliteal Artery”, *Investigative Radiology*, vol. 4, Sep.–Oct., 1969:329–332.

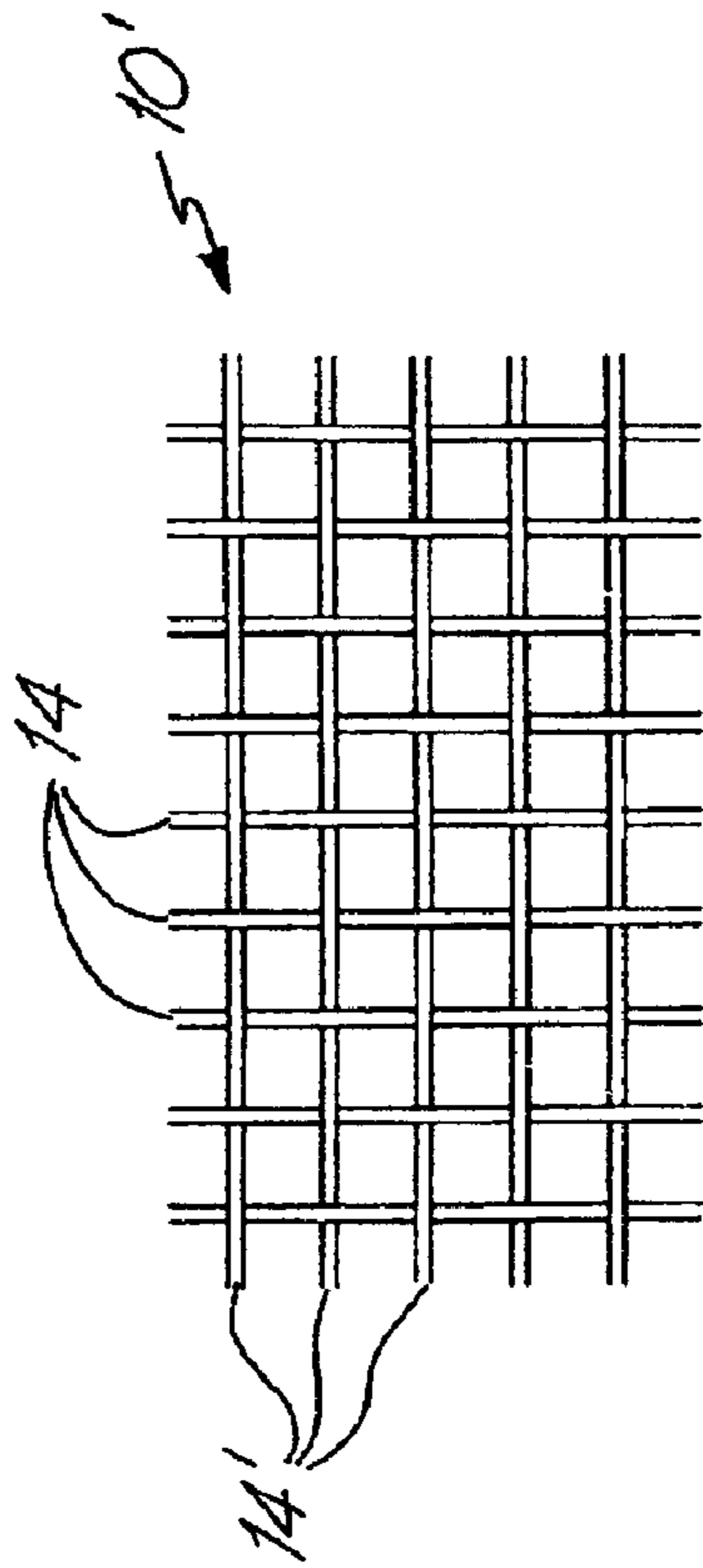

Fig. 10B

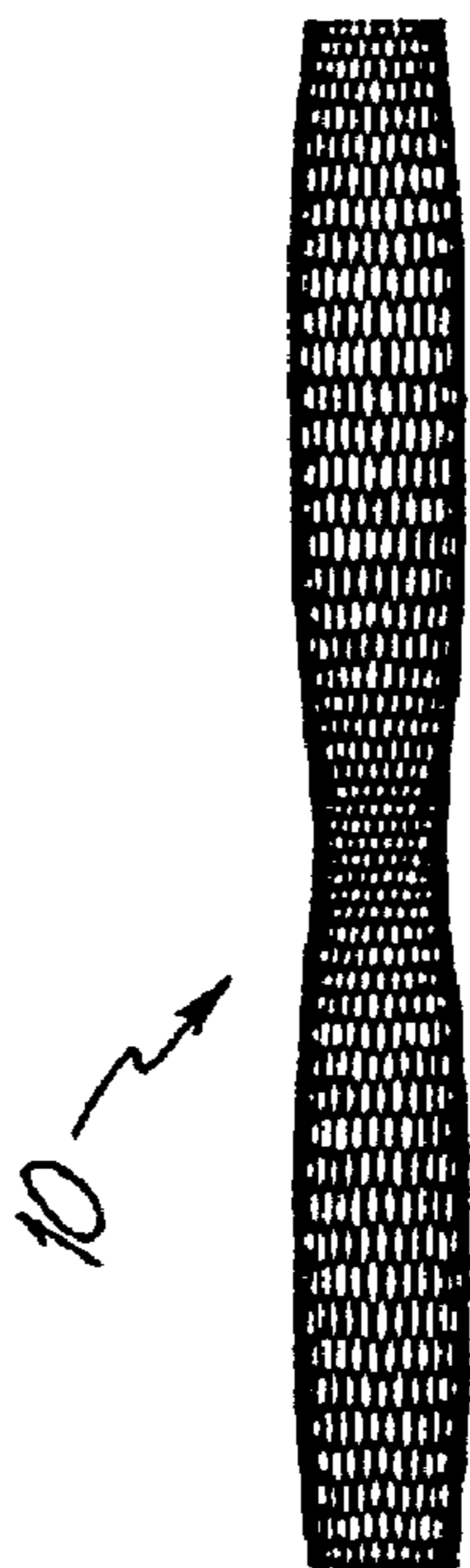

Fig. 10A

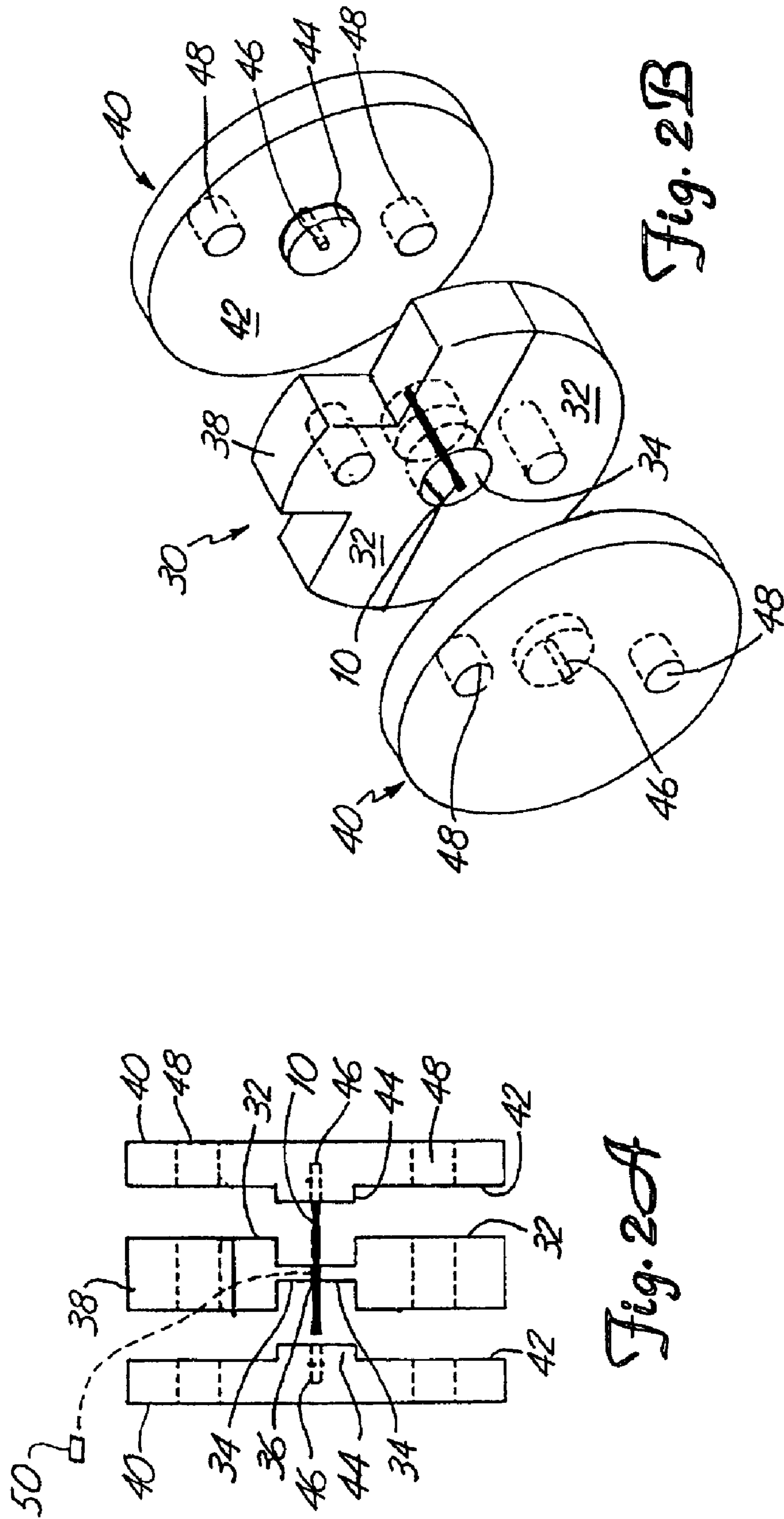

Fig. 2A

Fig. 2B

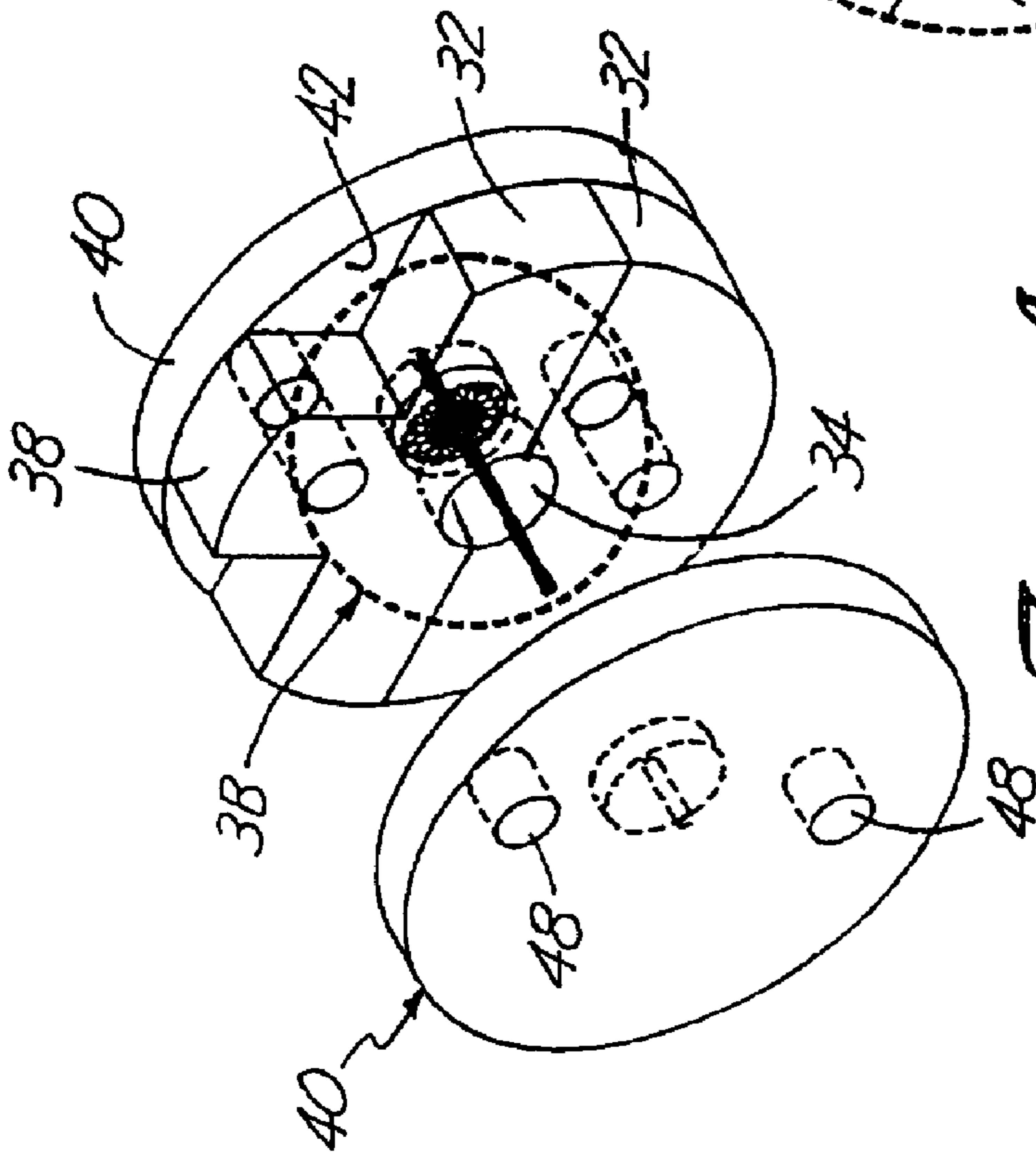

Fig. 3A

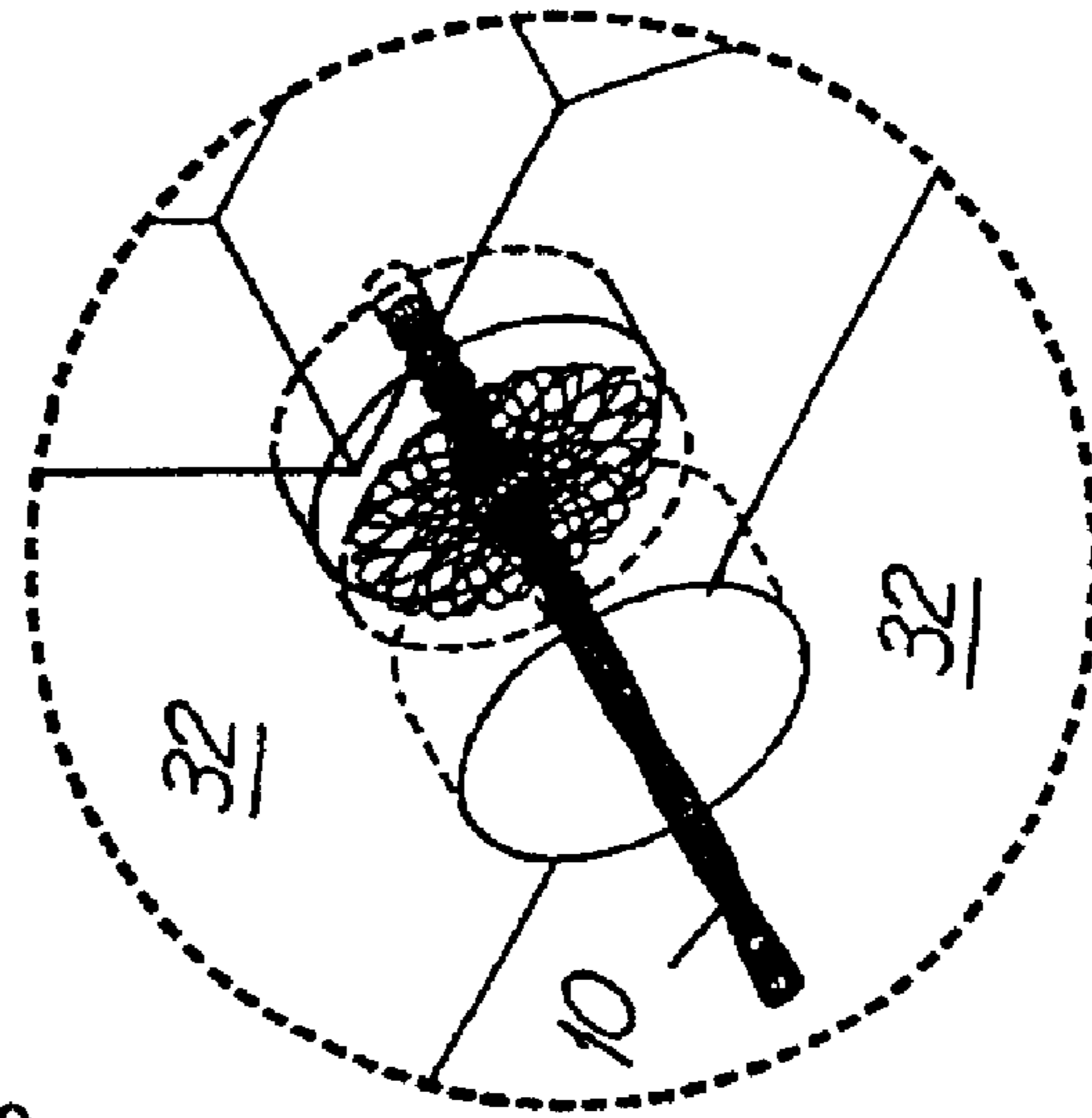

Fig. 3B

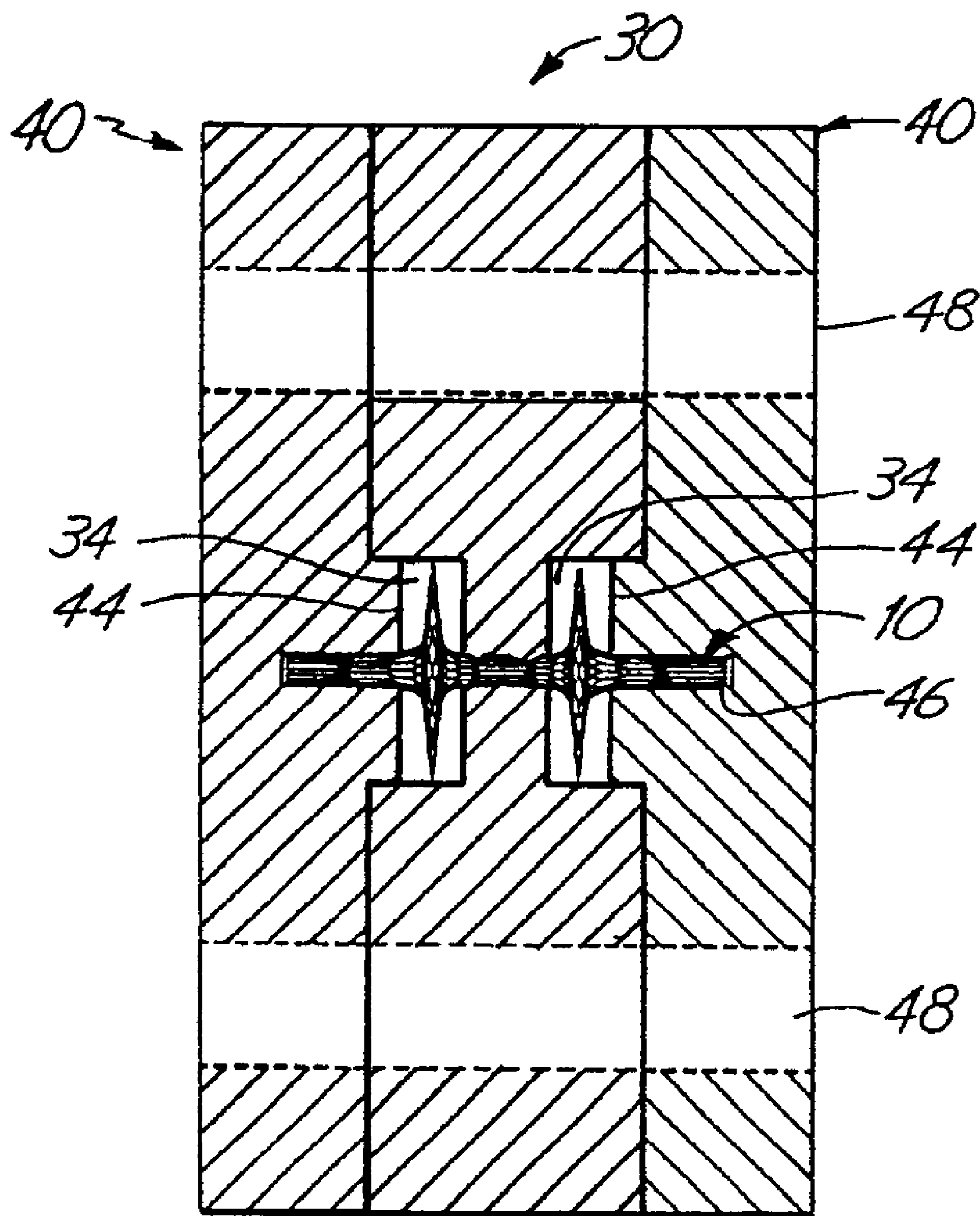

Fig. 4

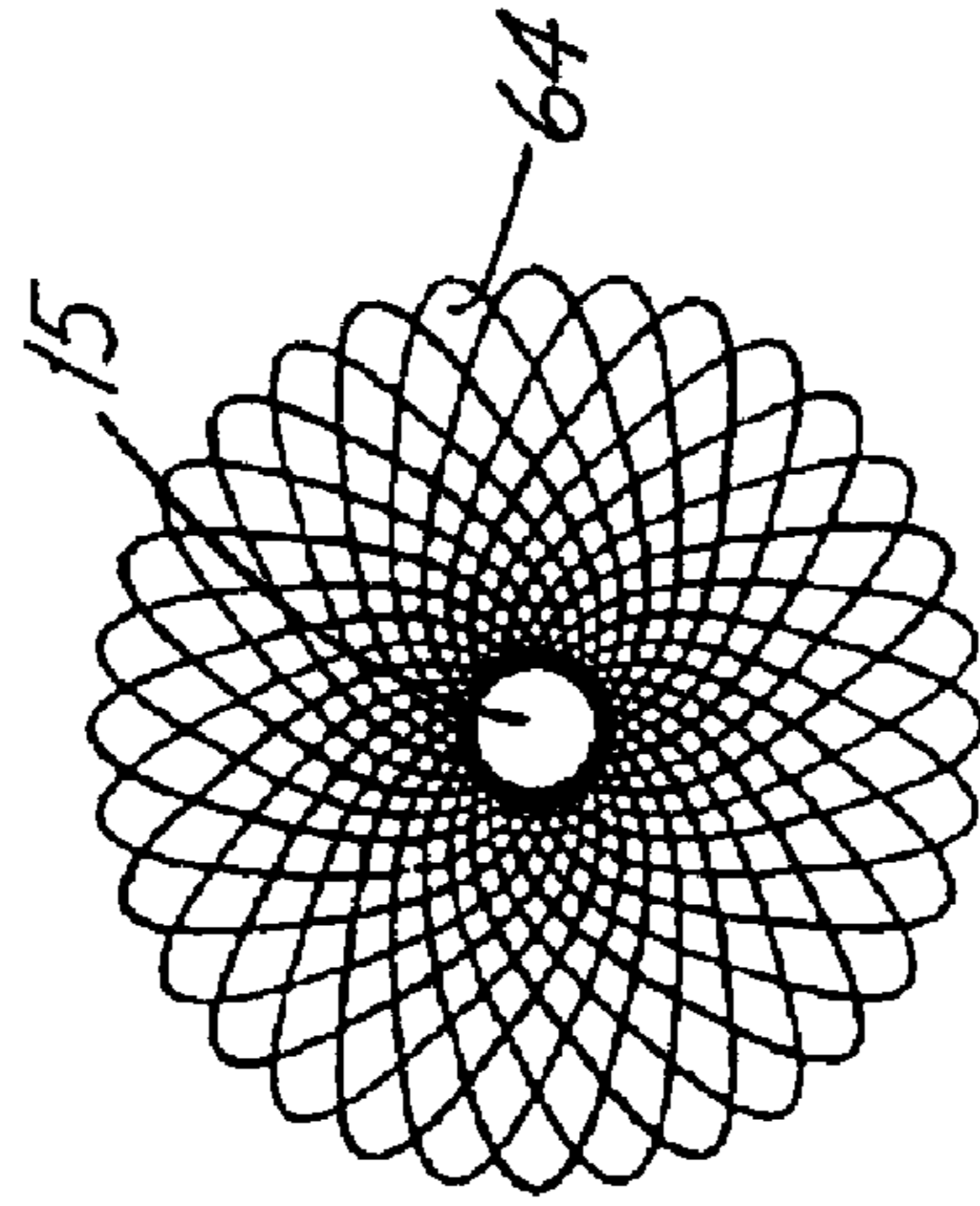

Fig. 5B

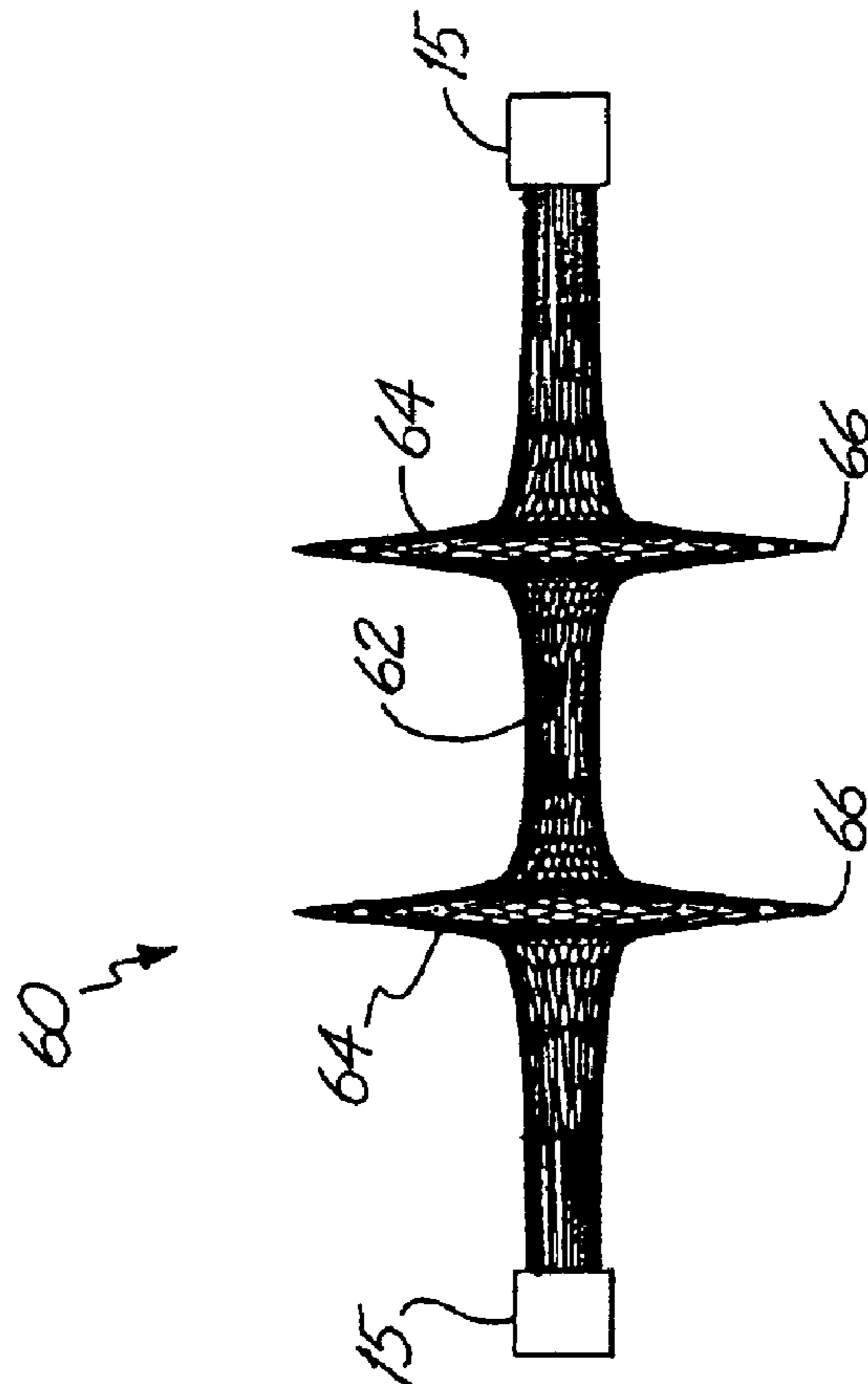

Fig. 5A



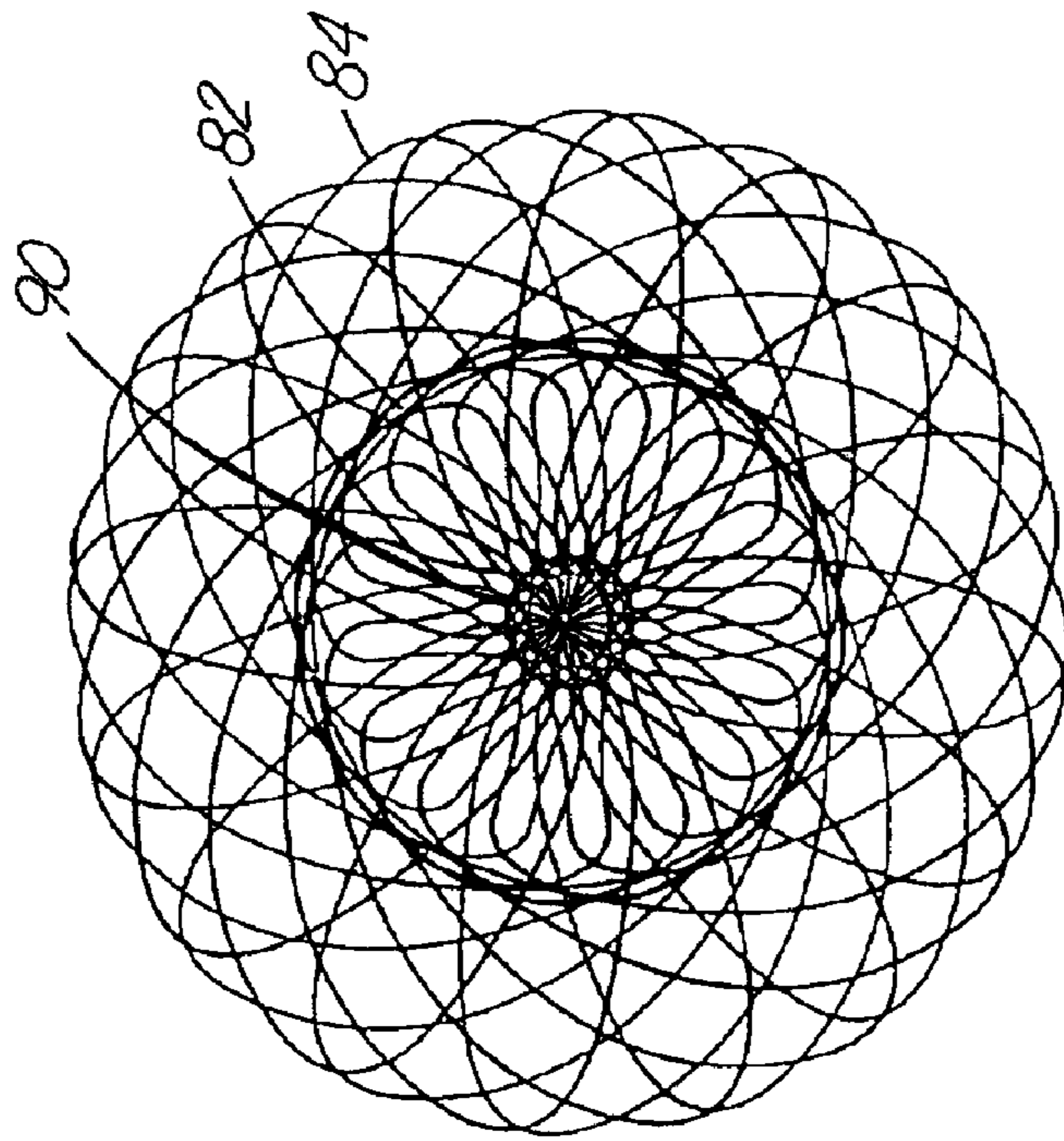

Fig. 6B

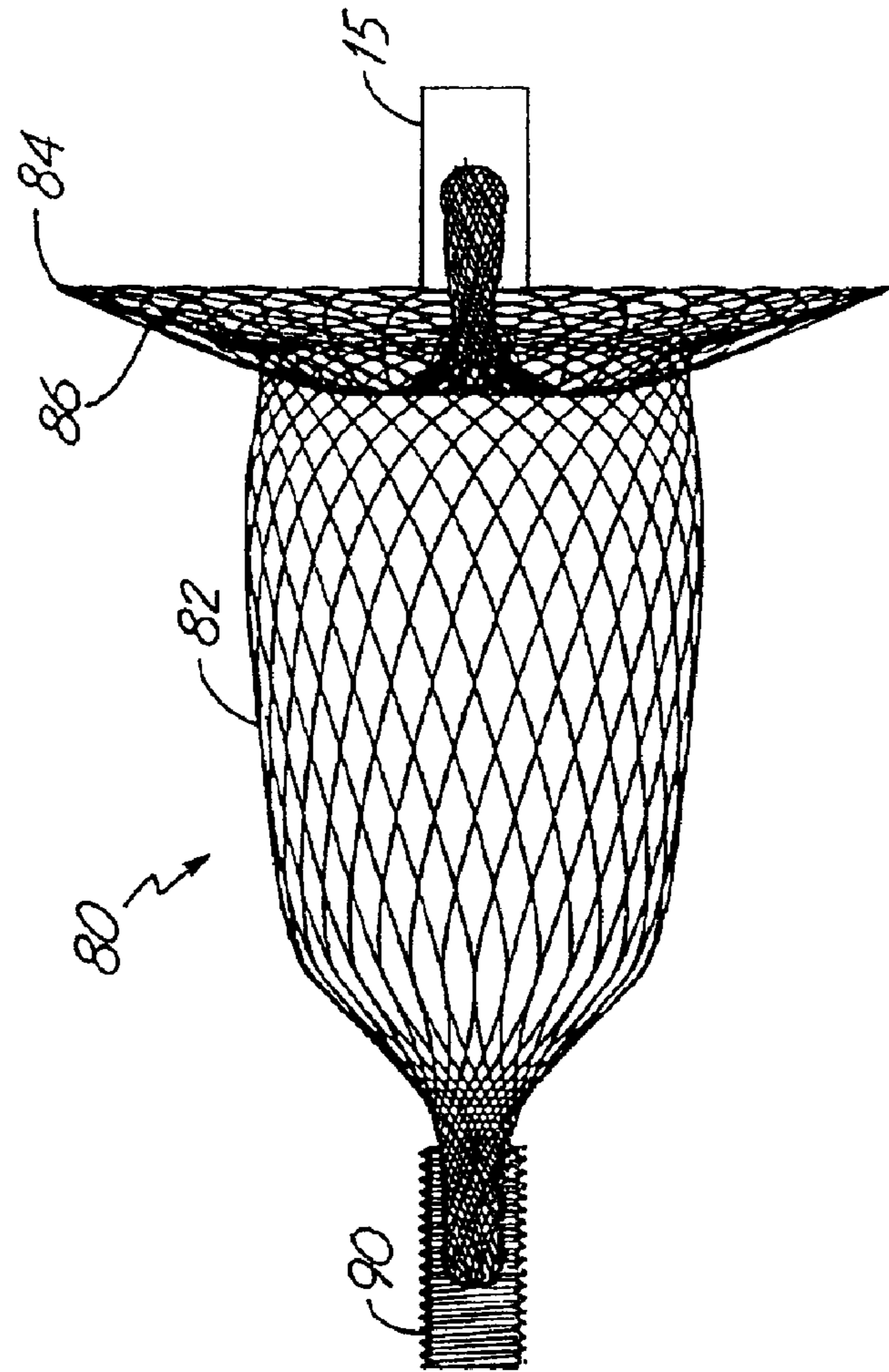

Fig. 6A

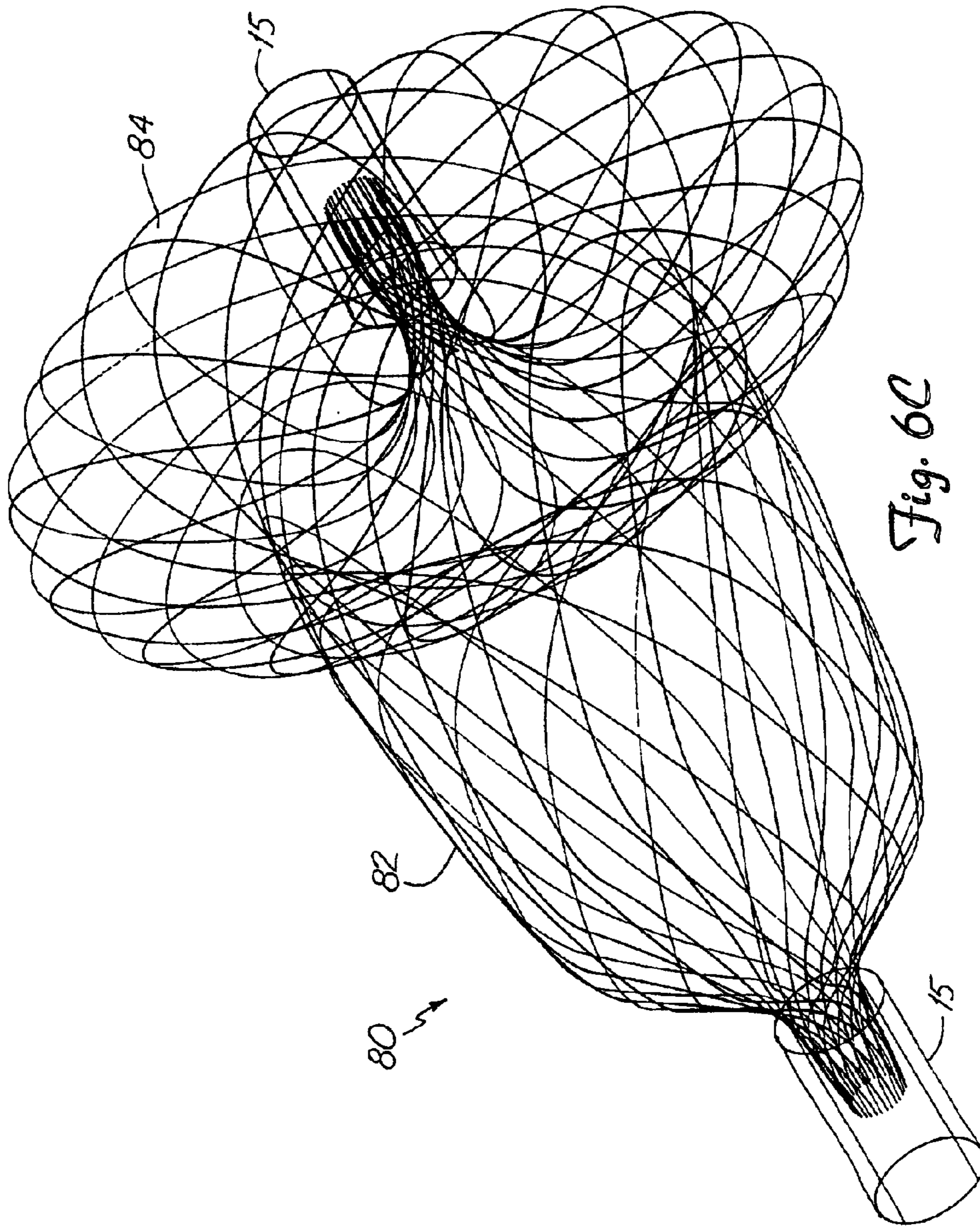

Fig. 6C

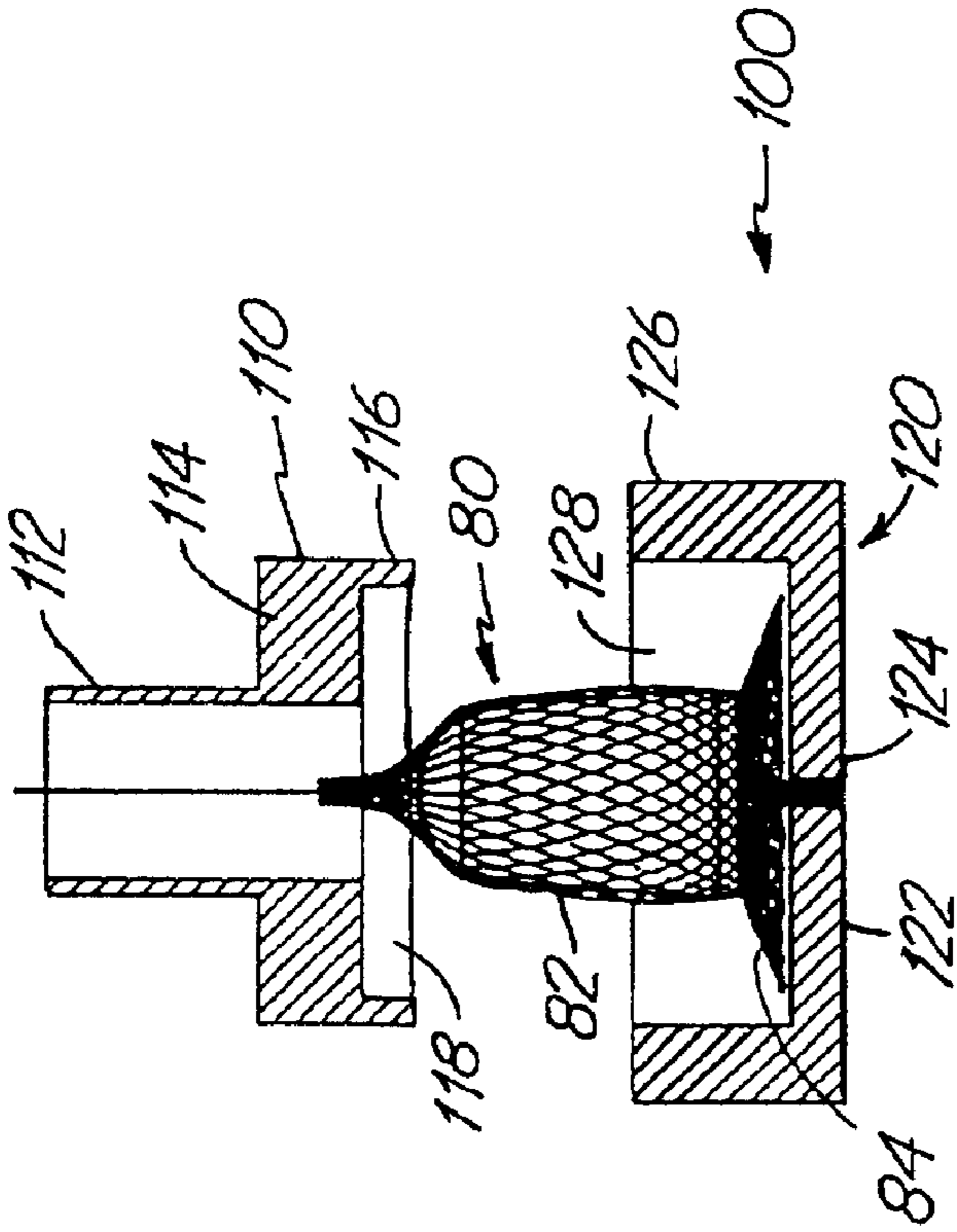

Fig. 7

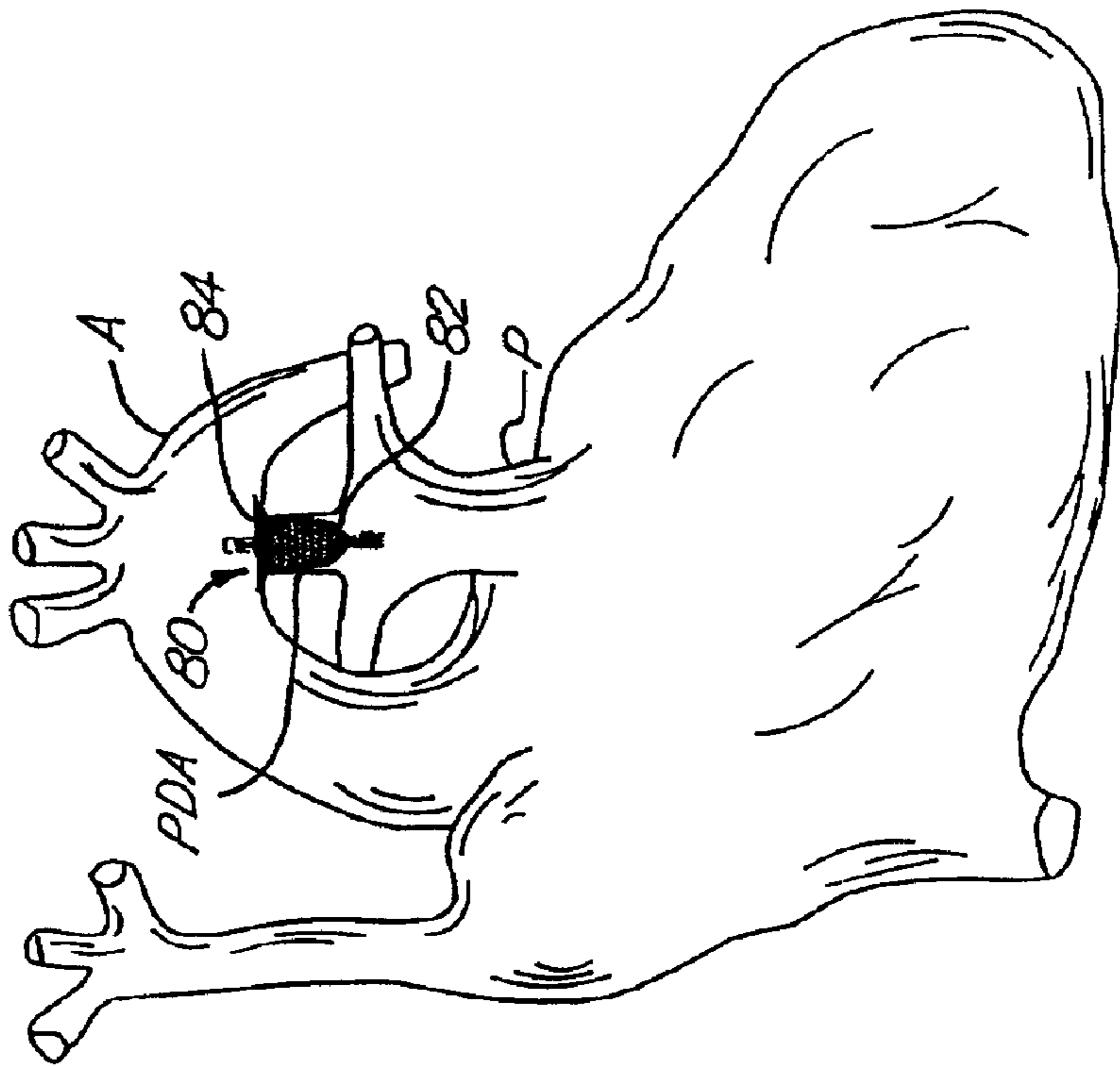

Fig. 8

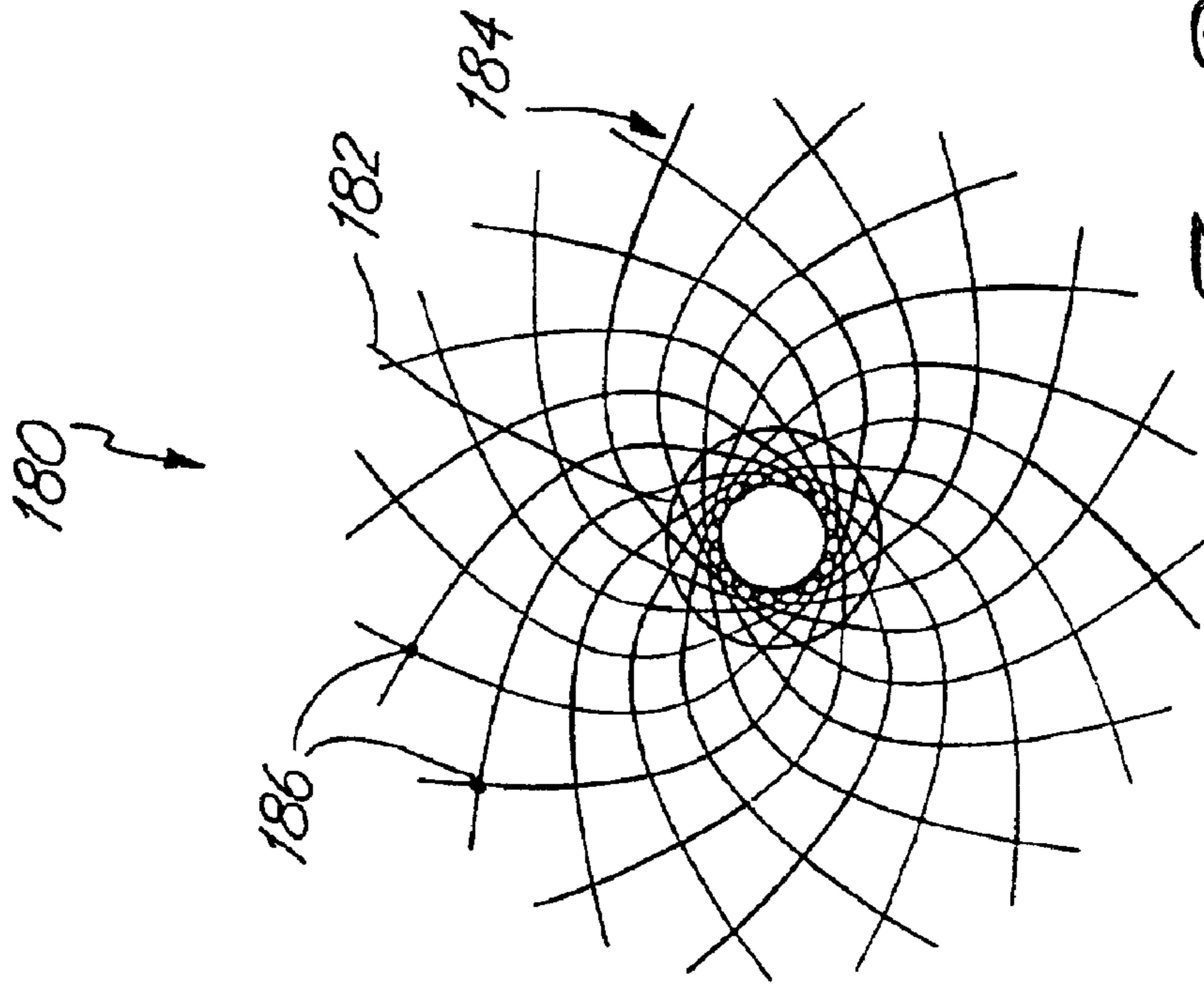

Fig. 9B

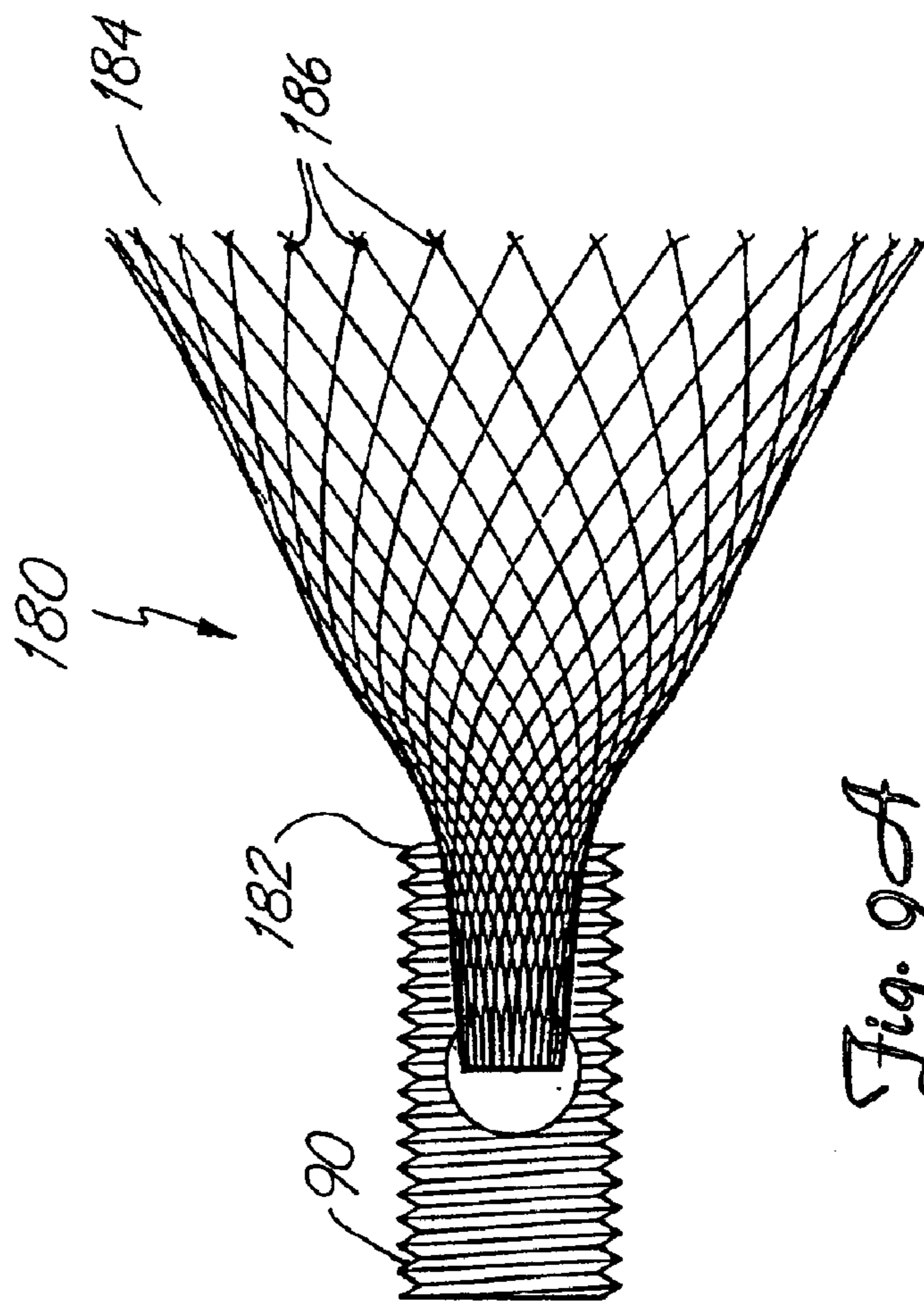

Fig. 9A

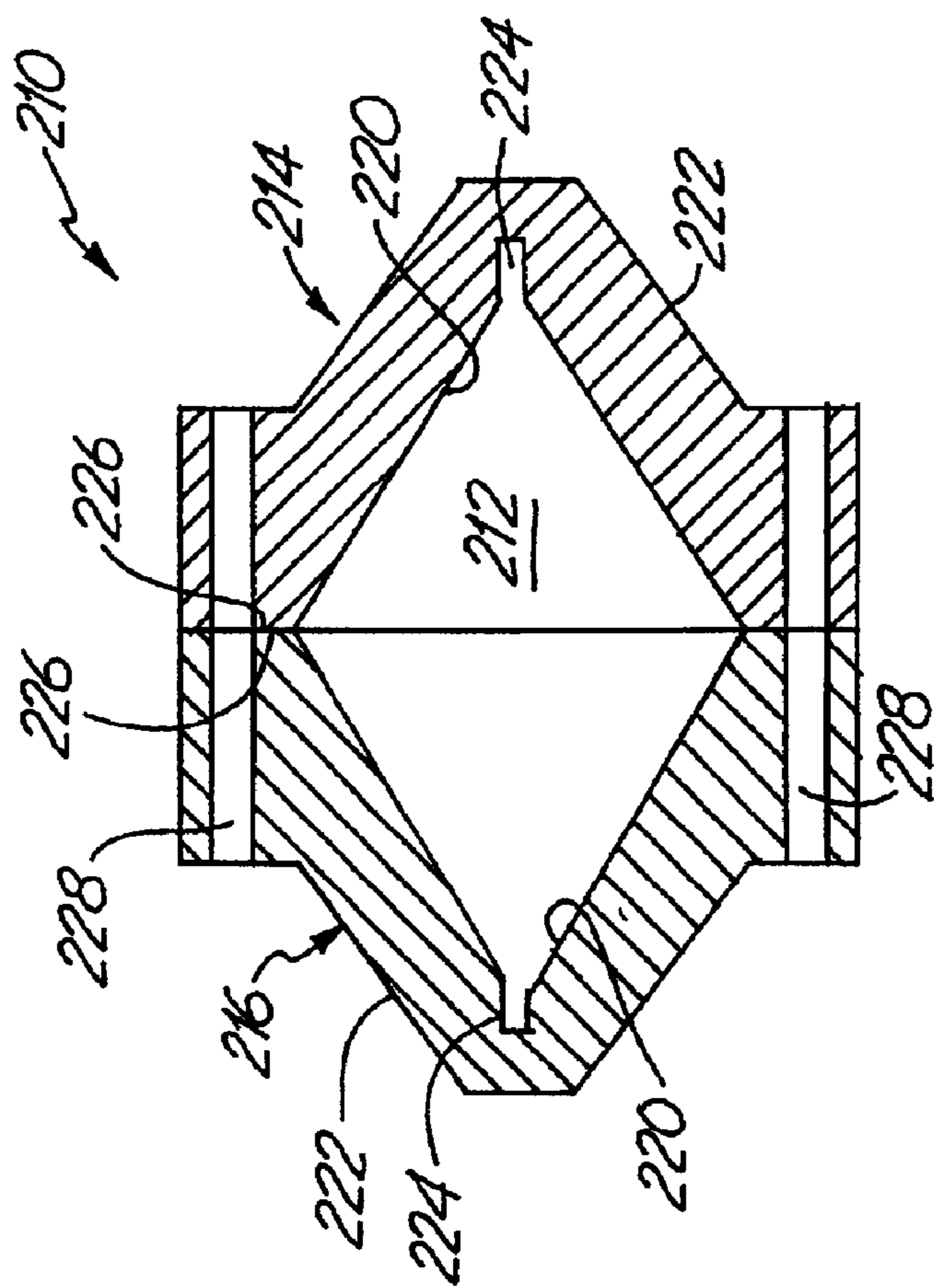

Fig. 10B

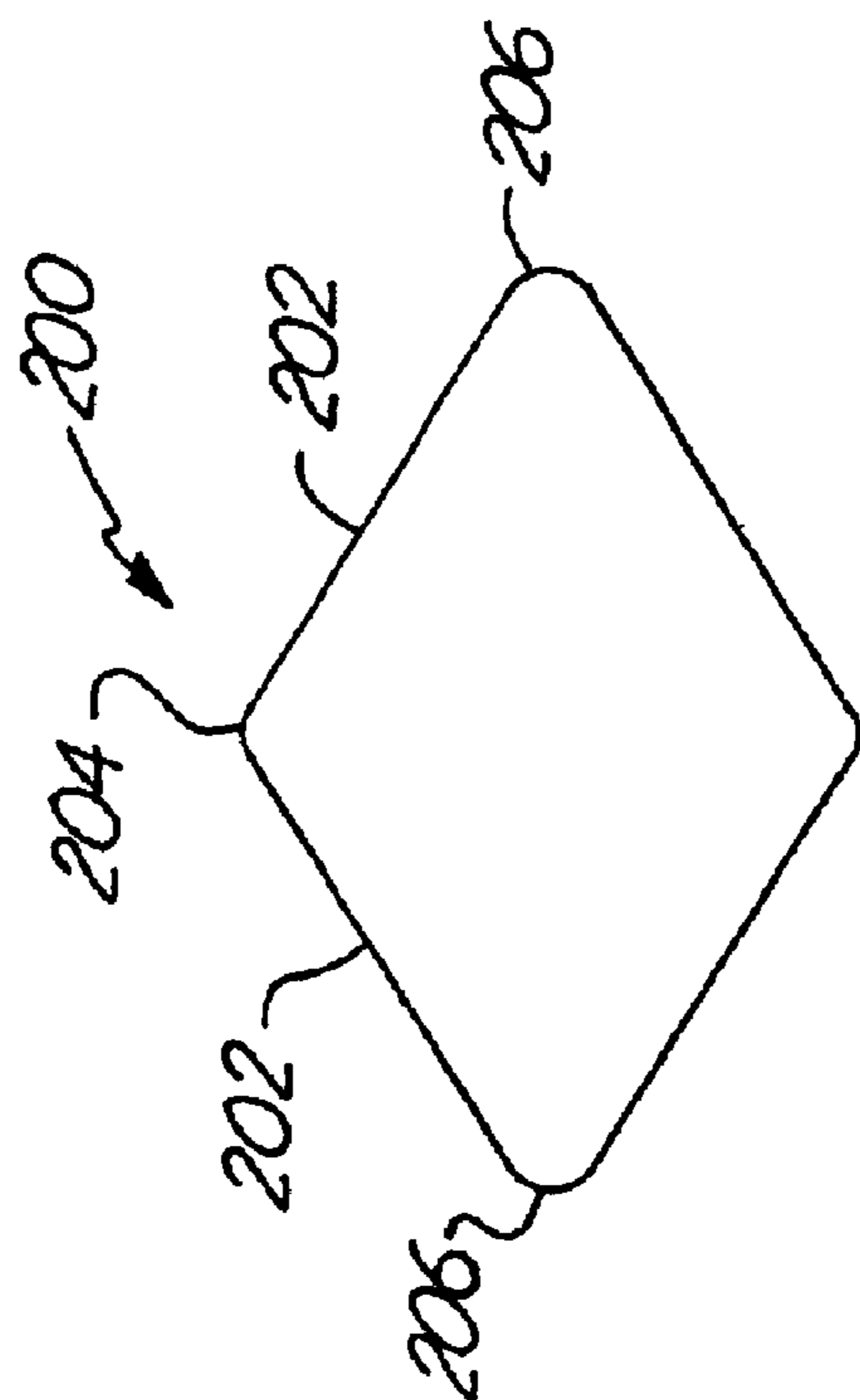

Fig. 10A

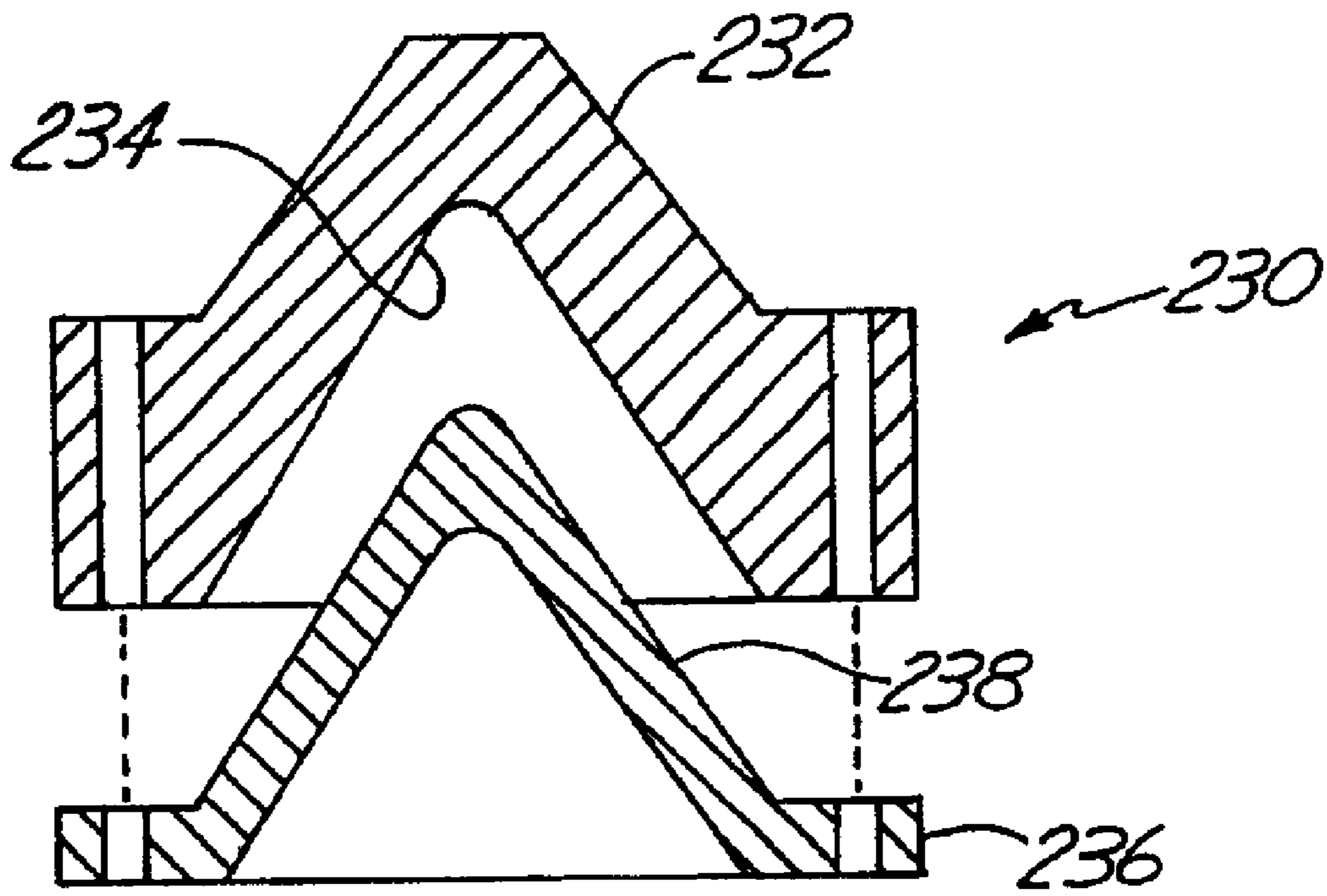

Fig. 10 C

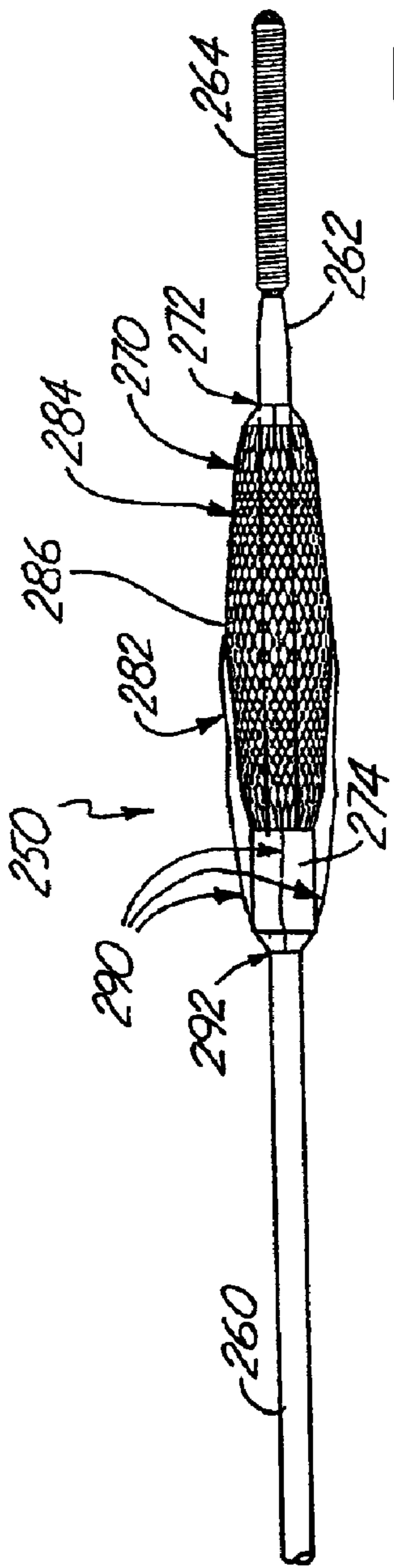

Fig. 11A

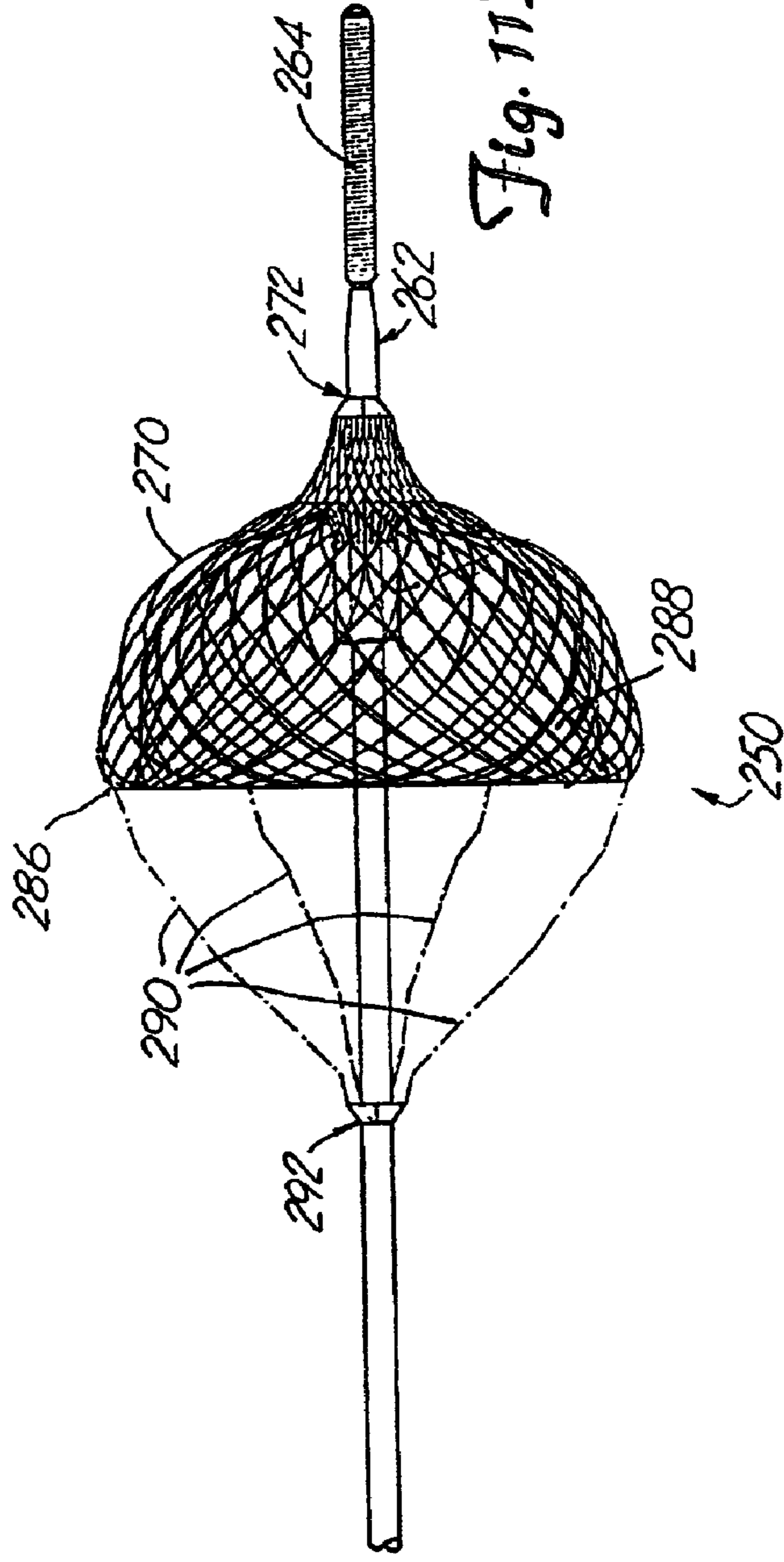

Fig. 11B

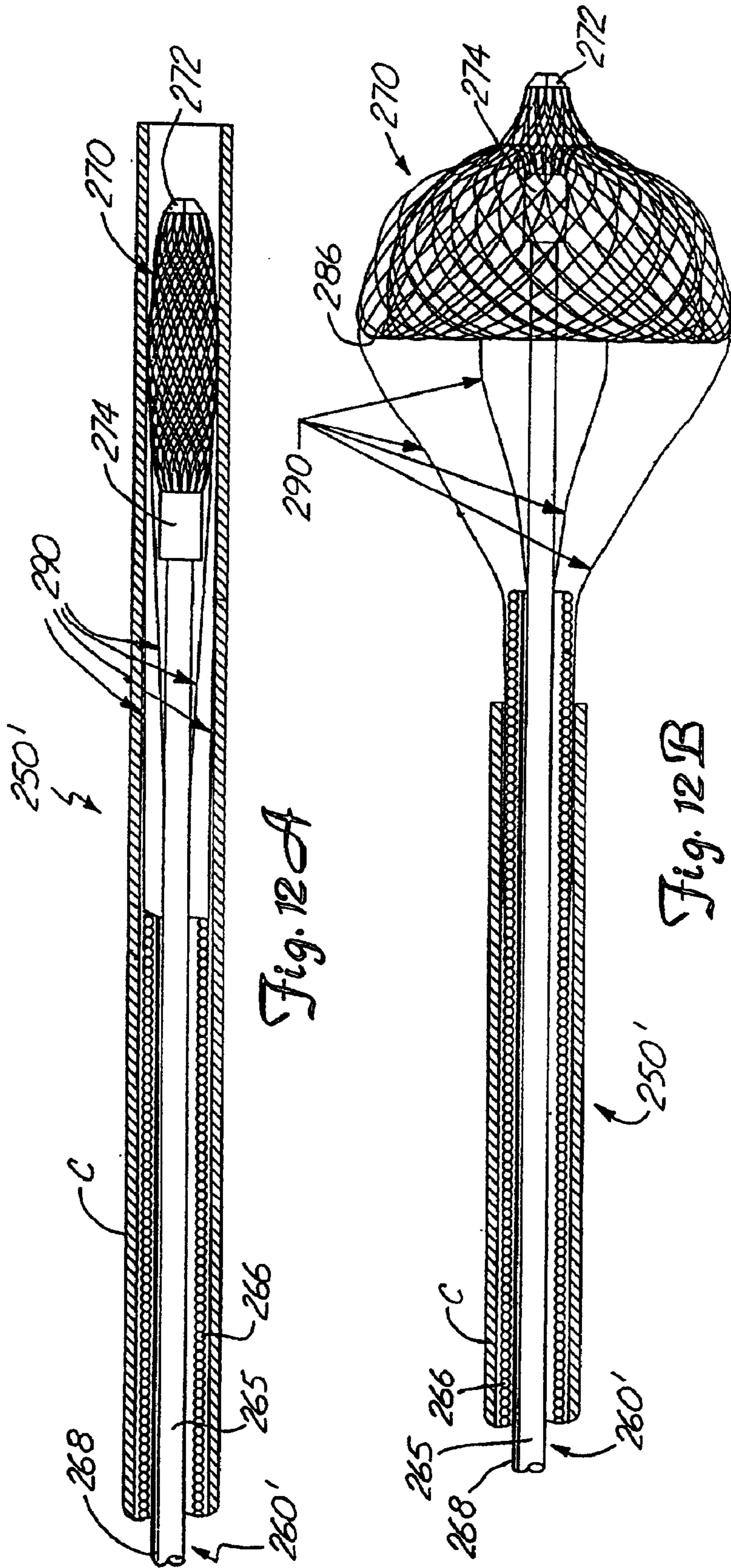
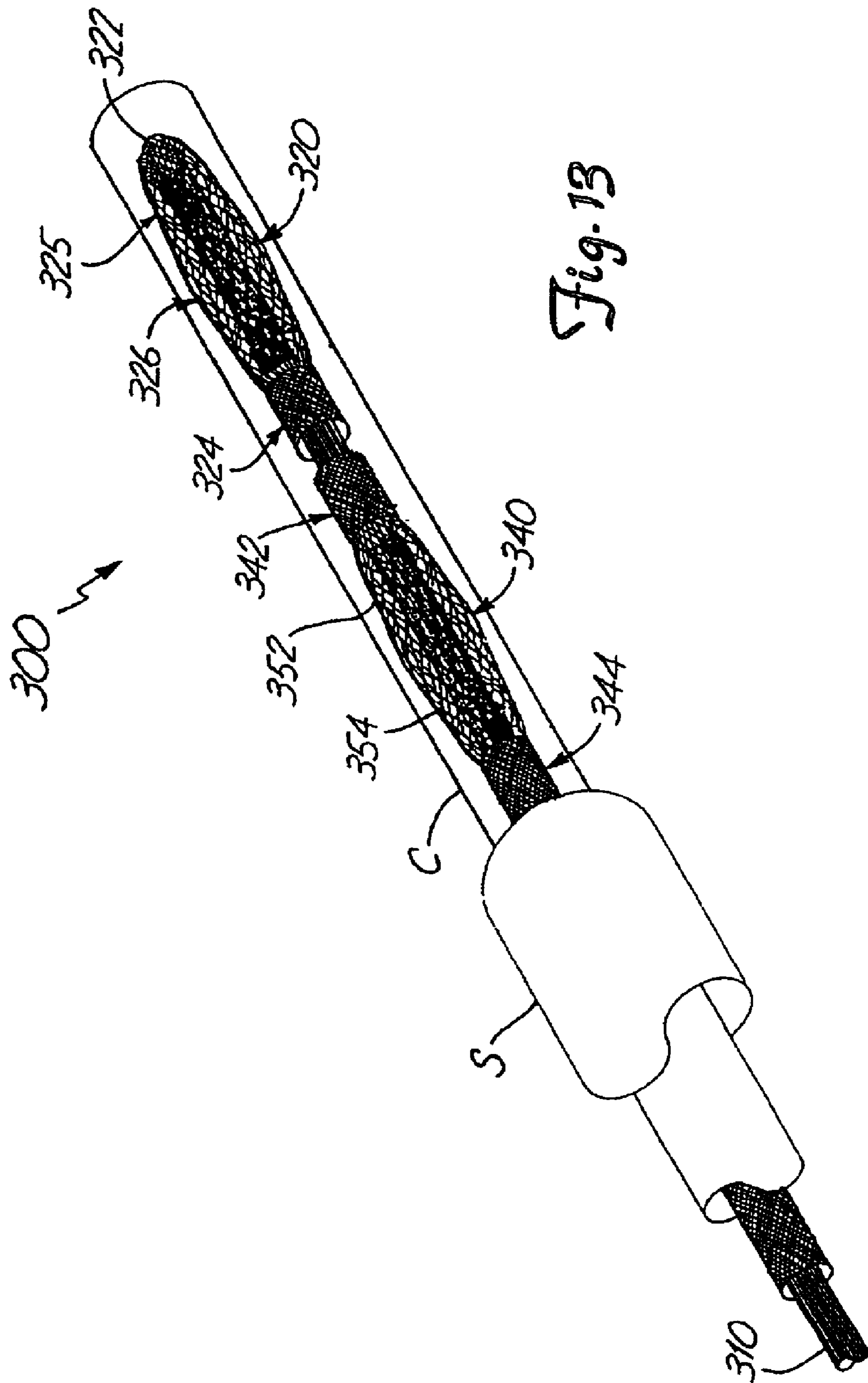

Fig. 12A

Fig. 12B





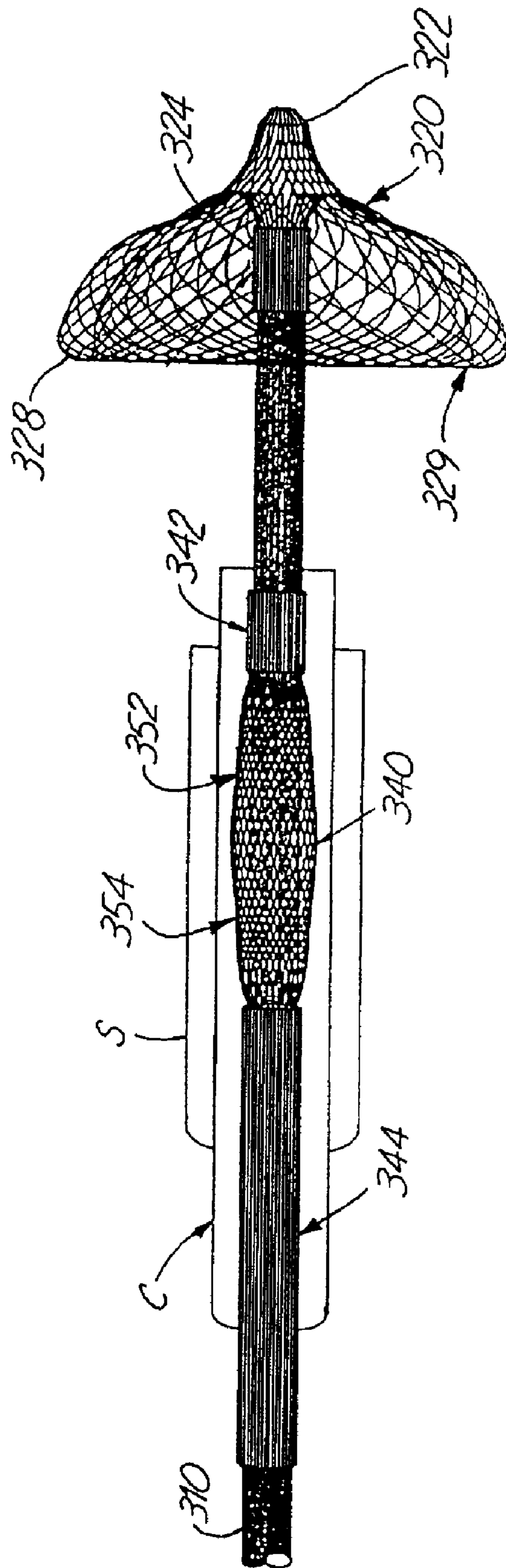

Fig. 14

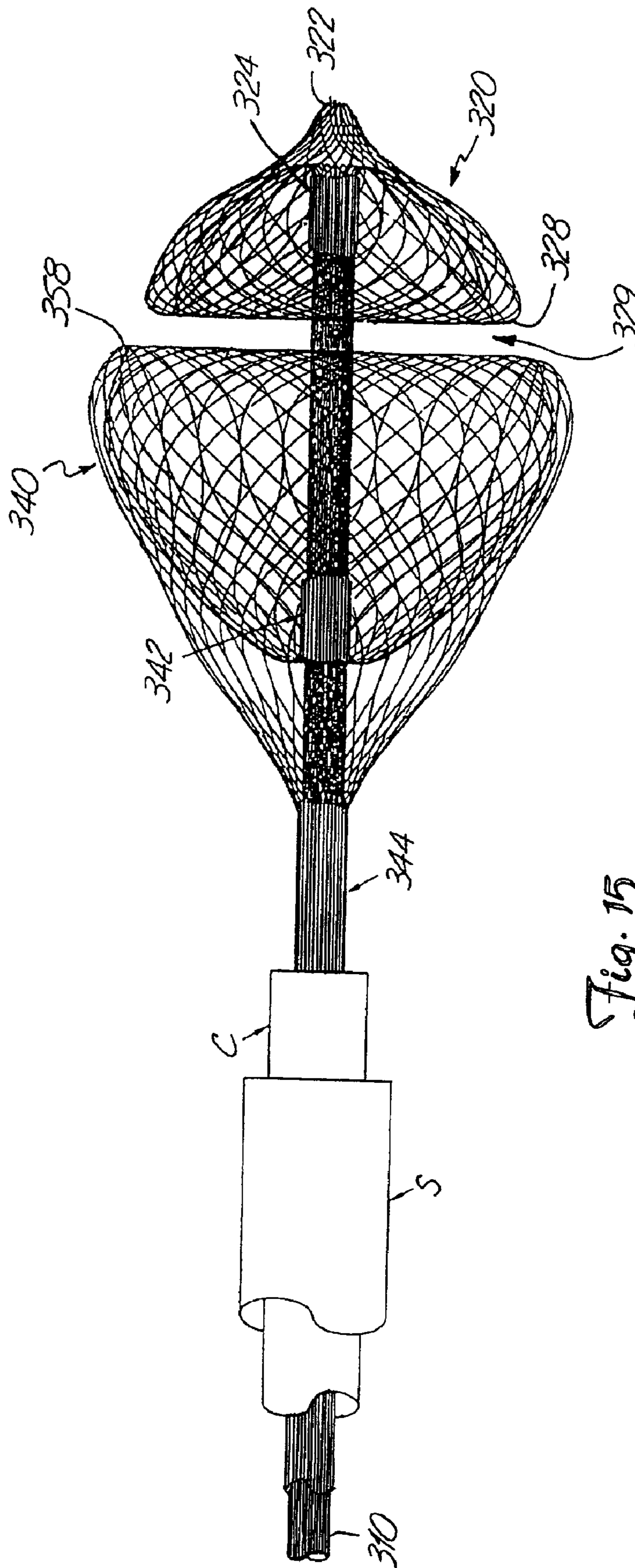

Fig. 15

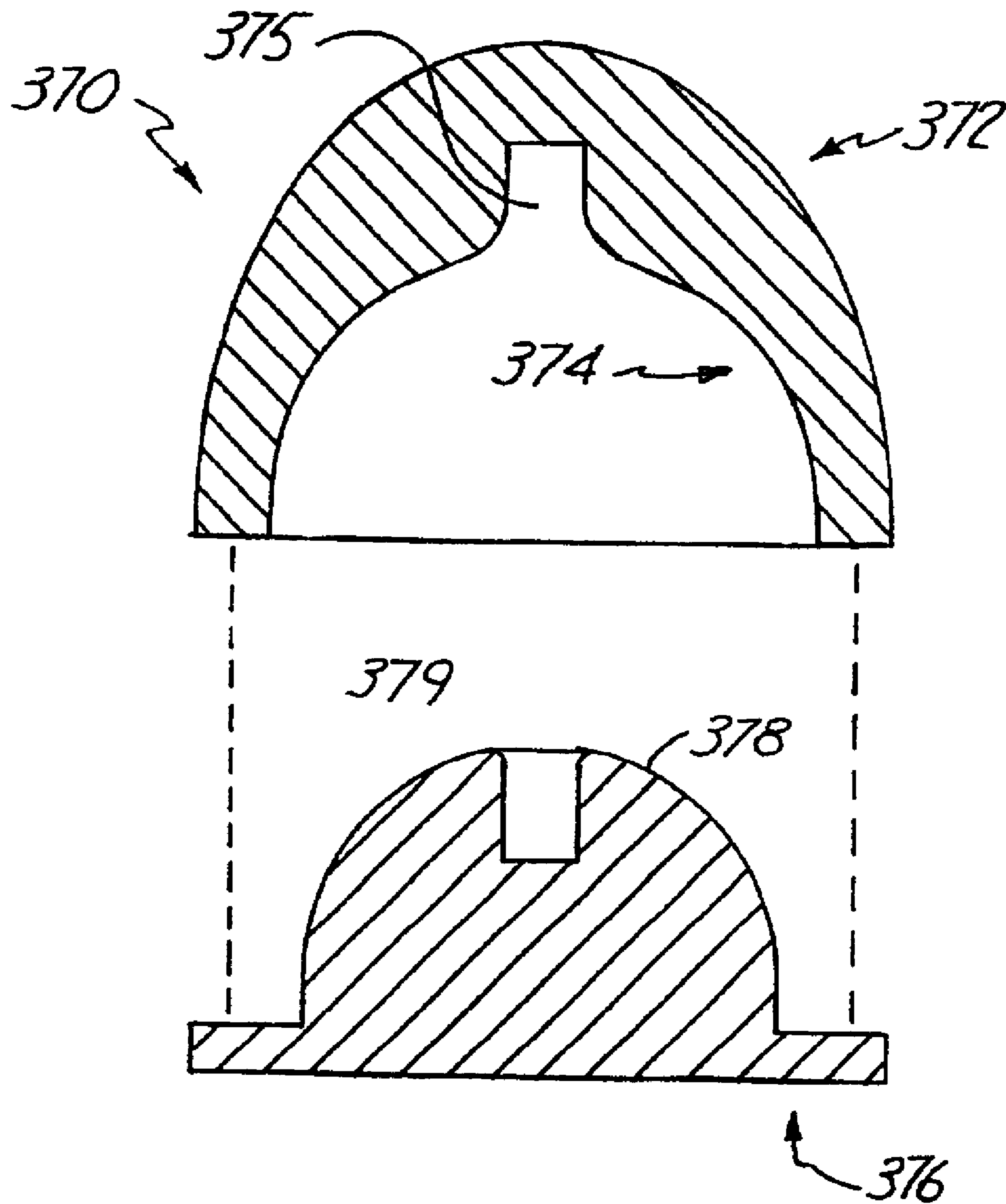

Fig. 16

## METHOD AND DEVICE FOR FILTERING BODY FLUID

This application is a continuation of application Ser. No. 08/748,066, filed Nov. 12, 1996 now U.S. Pat. No. 6,605, 102 which is a continuation of application Ser. No. 08/272, 425, filed Jul. 8, 1994 now abandoned.

### FIELD OF THE INVENTION

The present invention generally relates to intravascular devices for treating certain medical conditions and, more particularly, provides a method of forming intravascular devices and certain novel intravascular occlusion devices. The devices made in accordance with the invention are particularly well suited for delivery through a catheter or the like to a remote location in a patient's vascular system or in analogous vessels within a patient's body.

### BACKGROUND OF THE INVENTION

A wide variety of intravascular devices are used in various medical procedures. Certain intravascular devices, such as catheters and guidewires, are generally used simply to deliver fluids or other medical devices to specific locations within a patient's body, such as a selective site within the vascular system. Other, frequently more complex, devices are used in treating specific conditions, such as devices used in removing vascular occlusions or for treating septal defects and the like.

In certain circumstances, it may be necessary to occlude a patient's vessel, such as to stop blood flow through an artery to a tumor or other lesion. Presently, this is commonly accomplished simply by inserting, e.g. Ivalon particles, a trade name for vascular occlusion particles, and short sections of coil springs into a vessel at a desired location. These "embolization agents" will eventually become lodged in the vessel, frequently floating downstream of the site at which they are released before blocking the vessel. In part due to the inability to precisely position the embolization agents, this procedure is often limited in its utility.

Detachable balloon catheters are also used to block patients' vessels. When using such a catheter, an expandable balloon is carried on a distal end of a catheter. When the catheter is guided to the desired location, the balloon is filled with a fluid until it substantially fills the vessel and becomes lodged therein. Resins which will harden inside the balloon, such as an acrylonitrile, can be employed to permanently fix the size and shape of the balloon. The balloon can then be detached from the end of the catheter and left in place.

Such balloon embolizations are also prone to certain safety problems, though. For example, if the balloon is not filled enough, it will not be firmly fixed in the vessel and may drift downstream within the vessel to another location, much like the loose embolization agents noted above. In order to avoid this problem, physicians may overfill the balloons; it is not uncommon for balloons to rupture and release the resin into the patient's bloodstream.

In still other procedures, it may not be necessary to permanently occlude a vessel, but it may be necessary to provide a filter or the like to prevent thrombi from passing a particular location. For example, rotating burrs are used in removing atheroma from the lumen of patients' blood vessels. These burrs can effectively dislodge the atheroma, but the dislodged material will simply float downstream with the flow of blood through the vessel unless steps are taken to capture the material.

Some researchers have proposed various traps or filters for capturing the particulate matter released or created in

such procedures. However, such filters generally have not proven to be exceptionally effective in actual use. Such filters tend to be cumbersome to use and accurate deployment is problematic because if they are not properly seated in the vessel they can drift to a more distal site where they are likely to do more harm than good. In addition, these filters are generally capable of only trapping relatively large thrombi and are not effective means for removing smaller embolic particles from the blood stream.

The problems with temporary filters, which are intended to be used only during a particular procedure then retracted with the thrombi trapped therein, are more pronounced. Even if the trap does effectively capture the dislodged material, it has proven to be relatively difficult or complex to retract the trap back into the catheter through which it was delivered without simply dumping the trapped thrombi back into the blood stream, defeating the purpose of the temporary filter device. For this reason, most atherectomy devices and the like tend to aspirate the patient's blood during the procedure to remove the dislodged material entrained therein.

Mechanical embolization devices, filters and traps have been proposed in the past. Even if some of those devices have proven effective, they tend to be rather expensive and time-consuming to manufacture. For example, some intravascular blood filters suggested by others are formed of a plurality of specially-shaped legs which are adapted to fill the vessel and dig into the vessel walls. In making most such filters, the legs must be individually formed and then painstakingly attached to one another, frequently entirely by hand, to assemble the final filter. Not only does this take significant skilled manpower, and hence increase the costs of such devices, the fact that each item must be made by hand tends to make quality control more difficult. This same difficulty and expense of manufacturing is not limited to such filters, but is experienced in many other intravascular devices as well.

Accordingly, it would be desirable to provide a method for forming devices for deployment in a patient's vessel which is both economical and yields consistent, reproducible results. It would also be advantageous to provide a reliable embolization device which is both easy to deploy and can be accurately placed in a vessel. Furthermore, there is a need in the art for a trap or filter which can be deployed within a vessel for capturing thrombi, which trap can be reliably deployed; If the trap is to be used only temporarily, it should be readily withdrawn from the patient without simply dumping the trapped thrombi back into the blood stream.

### SUMMARY OF THE INVENTION

The present invention provides a method for forming intravascular devices from a resilient metal fabric and medical devices which can be formed in accordance with this method. In the method of the invention, a metal fabric formed of a plurality of resilient strands is provided, with the wires being formed of a resilient material which can be heat treated to substantially set a desired shape. This fabric is then deformed to generally conform to a molding surface of a molding element and the fabric is heat treated in contact with the surface of the molding element at an elevated temperature. The time and temperature of the heat treatment is selected to substantially set the fabric in its deformed state. After the heat treatment, the fabric is removed from contact with the molding element and will substantially retain its shape in the deformed state. The fabric so treated defines an

expanded state of a medical device which can be deployed through a catheter into a channel in a patient's body.

In accordance with the method of the invention, a distal end of a catheter can be positioned in a channel in a patient's body to position the distal end of the catheter adjacent a treatment site for treating a physiological condition. A medical device made in accordance with the process outlined above can be collapsed and inserted into the lumen of the catheter. The device is urged through the catheter and out the distal end, whereupon it will tend to return to its expanded state adjacent the treatment site.

Further embodiments of the present invention also provide specific medical devices which may be made in accordance with the present invention. Such devices of the invention are formed of a metal fabric and have an expanded configuration and a collapsed configuration. The devices are collapsed for deployment through a catheter and, upon exiting the distal end of the catheter in a patient's channel, will resiliently substantially return to their expanded configuration. In accordance with a first of these embodiments, a generally elongate medical device has a generally tubular middle portion and a pair of expanded diameter portions, with one expanded diameter portion positioned at either end of the middle portion. In another embodiment, the medical device is generally bell-shaped, having an elongate body having a tapered first end and a larger second end, the second end presenting a fabric disc which will be oriented generally perpendicular to an axis of a channel when deployed therein.

#### BRIEF DESCRIPTION OF THE DRAWINGS

FIGS. 1A and 1B each depict a metal fabric suitable for use with the invention;

FIGS. 2A and 2B are a side view and a perspective view, respectively, of a molding element and a length of a metal fabric suitable for use in forming a medical device in accordance with the invention, the mold being in a disassembled state;

FIG. 3A is a perspective view showing the molding element and metal fabric of FIG. 2 in a partially assembled state;

FIG. 3B is a close-up view of the highlighted area of FIG. 3A showing the compression of the metal fabric in the molding element;

FIG. 4 is a cross-sectional view showing the molding element and metal fabric of FIG. 2 in an assembled state;

FIGS. 5A and 5B are a side view and an end view, respectively, of a medical device in accordance with the invention;

FIGS. 6A-6C are a side view, an end view and a perspective view, respectively, of a medical device in accordance with another embodiment of the invention;

FIG. 7 is a side, cross sectional view of a molding element suitable for forming the medical device shown in FIGS. 6A-6C;

FIG. 8 is a schematic illustration showing the device of FIGS. 6A-6C deployed in a channel of a patient's vascular system to occlude a Patent Ductus Arteriosus;

FIGS. 9A and 9B are a side view and an end view, respectively, of a medical device in accordance with yet another embodiment of the invention;

FIG. 10A is a side view of one molding element suitable for forming the invention of FIGS. 9A and 9B;

FIG. 10B is a cross-sectional view of another molding element suitable for forming the invention of FIGS. 9A and 9B;

FIG. 10C is a cross-sectional view of still another molding element suitable for forming the invention of FIGS. 9A and 9B;

FIG. 11A is a schematic side view of yet another medical device made in accordance with the invention showing the device in a collapsed state for deployment in a patient's vascular system;

FIG. 11B is a schematic side view of the medical device of FIG. 11A in an expanded state for deployment in a patient's vascular system;

FIG. 12A is a schematic side view of an alternative embodiment of the invention of FIG. 11A showing the device in a collapsed state within catheter for deployment;

FIG. 12B is a schematic side view of the device of FIG. 12A showing the device deployed distally of the catheter;

FIG. 13 is a schematic perspective view showing a medical device in accordance with yet a further embodiment of the invention collapsed within a catheter for deployment in a channel in a patient's body;

FIG. 14 is a schematic side view of the device of FIG. 13 in a partially deployed state; and

FIG. 15 is a schematic side view of the device of FIG. 13 in a fully deployed state.

FIG. 16 is a cross-sectional view of one molding element suitable for forming the invention of FIGS. 11A, 11B, 12A, and 12B.

#### DETAILED DESCRIPTION OF THE PREFERRED EMBODIMENTS

The present invention provides a reproducible, relatively inexpensive method of forming devices for use in channels in patients' bodies, such as vascular channels, urinary tracts, biliary ducts and the like, as well as devices which may be made via that method. In forming a medical device via the method of the invention, a metal fabric 10 is provided. The fabric is formed of a plurality of wire strands having a predetermined relative orientation between the strands. FIGS. 1A and 1B illustrate two examples of metal fabrics which are suitable for use in the method of the invention.

In the fabric of FIG. 1A, the metal strands define two sets of essentially parallel generally helical strands, with the strands of one set having a "hand", i.e. a direction of rotation, opposite that of the other set. This defines a generally tubular fabric, known in the fabric industry as a tubular braid. Such tubular braids are well known in the fabric arts and find some applications in the medical device field as tubular fabrics, such as in reinforcing the wall of a guiding catheter. As such braids are well known, they need not be discussed at length here. The pitch of the wire strands (i.e. the angle defined between the turns of the wire and the axis of the braid) and the pick of the fabric (i.e. the number of turns per unit length) may be adjusted as desired for a particular application. For example, if the medical device to be formed is to be used to occlude the channel in which it is placed, the pitch and pick of the fabric will tend to be higher than if the device is simply intended to filter bodily fluid passing therethrough.

For example, in using a tubular braid such as that shown in FIG. 1A to form a device such as that illustrated in FIGS. 5A and 5B, a tubular braid of about 4 mm in diameter with a pitch of about 50° and a pick of about 74 (per linear inch) would seem suitable for a devices used in occluding channels on the order of about 2 mm to about 4 mm in inner diameter, as detailed below in connection with the embodiment of FIGS. 5A and 5B.

FIG. 1B illustrates another type of fabric which is suitable for use in the method of the invention. This fabric is a more conventional fabric and may take the form of a flat woven sheet, knitted sheet or the like. In the woven fabric shown in FIG. 1B, there are also two sets **14** and **14'** of generally parallel strands, with one set of strands being oriented at an angle, e.g. generally perpendicular (having a pick of about 90°), with respect to the other set. As noted above, the pitch and pick of this fabric (or, in the case of a knit fabric, the pick and the pattern of the knit, e.g. Jersey or double knits) may be selected to optimize the desired properties of the final medical device.

The wire strands of the metal fabric used in the present method should be formed of a material which is both resilient and can be heat treated to substantially set a desired shape. Materials which are believed to be suitable for this purpose include a cobalt-based low thermal expansion alloy referred to in the field as Elgiloy, nickel based high-temperature high-strength "superalloys" commercially available from Haynes International under the trade name Hastelloy, nickel-based heat treatable alloys sold under the name Incoloy by International Nickel, and a number of different grades of stainless steel. The important factor in choosing a suitable material for the wires is that the wires retain a suitable amount of the deformation induced by the molding surface (as described below) when subjected to a predetermined heat treatment.

One class of materials which meet these qualifications are so-called shape memory alloys. Such alloys tend to have a temperature induced phase change which will cause the material to have a preferred configuration which can be fixed by heating the material above a certain transition temperature to induce a change in the phase of the material. When the alloy is cooled back down, the alloy will "remember" the shape it was in during the heat treatment and will tend to assume that configuration unless constrained from so doing.

One particularly preferred shape memory alloy for use in the present method is nitinol, an approximately stoichiometric alloy of nickel and titanium, which may also include other minor amounts of other metals to achieve desired properties. NiTi alloys such as nitinol, including appropriate compositions and handling requirements, are well known in the art and such alloys need not be discussed in detail here. For example, U.S. Pat. Nos. 5,067,489 (Lind) and 4,991,602 (Amplatz et al.), the teachings of which are incorporated herein by reference, discuss the use of shape memory NiTi alloys in guidewires. Such NiTi alloys are preferred, at least in part, because they are commercially available and more is known about handling such alloys than other known shape memory alloys. NiTi alloys are also very elastic—they are said to be "superelastic" or "pseudoelastic". This elasticity will help a device of the invention return to a present expanded configuration for deployment.

The wire strands can comprise a standard monofilament of the selected material, i.e. a standard wire stock may be used. If so desired, though, the individual wire strands may be formed from "cables" made up of a plurality of individual wires. For example, cables formed of metal wires where several wires are helically wrapped about a central wire are commercially available and NiTi cables having an outer diameter of 0.003 inches or less can be purchased. One advantage of certain cables is that they tend to be "softer" than monofilament wires having the same diameter and formed of the same material. Additionally, if the device being formed from the wire strands is to be used to occlude a vessel, the use of a cable can increase the effective surface area of the wire strand, which will tend to promote thrombosis.

In preparation of forming a medical device in keeping with the invention, an appropriately sized piece of the metal fabric is cut from the larger piece of fabric which is formed, for example, by braiding wire strands to form a long tubular braid. The dimensions of the piece of fabric to be cut will depend, in large part, upon the size and shape of the medical device to be formed therefrom.

When cutting the fabric to the desired dimensions, care should be taken to ensure that the fabric will not unravel. In the case of tubular braids formed of NiTi alloys, for example, the individual wire strands will tend to return to their heat-set configuration unless constrained. If the braid is heat treated to set the strands in the braided configuration, they will tend to remain in the braided form and only the ends will become frayed. However, it may be more economical to simply form the braid without heat treating the braid since the fabric will be heat treated again in forming the medical device, as noted below.

In such untreated NiTi fabrics, the strands will tend to return to their unbraided configuration and the braid can unravel fairly quickly unless the ends of the length of braid cut to form the device are constrained relative to one another. One method which has proven to be useful to prevent the braid from unraveling is to clamp the braid at two locations and cut the braid to leave a length of the braid having clamps (**15** in FIG. 2) at either end, thereby effectively defining an empty space within a sealed length of fabric. These clamps **15** will hold the ends of the cut braid together and prevent the braid from unraveling.

Alternatively, one can solder, braze, weld or otherwise affix the ends of the desired length together (e.g. with a biocompatible cementitious organic material) before cutting the braid. Although soldering and brazing of NiTi alloys has proven to be fairly difficult, the ends can be welded together, such as by spot welding with a laser welder.

The same problems present themselves when a flat sheet of fabric such as the woven fabric shown in FIG. 1B is used. With such a fabric, the fabric can be inverted upon itself to form a recess or depression and the fabric can be clamped about this recess to form an empty pocket (not shown) before the fabric is cut. If it is desired to keep the fabric in a generally flat configuration, it may be necessary to weld the junctions of the strands together adjacent the periphery of the desired piece of fabric before that piece is cut from the larger sheet. So connecting the ends of the strands together will prevent fabrics formed of untreated shape memory alloys and the like from unraveling during the forming process.

Once an appropriately sized piece of the metal fabric is obtained, the fabric is deformed to generally conform to a surface of a molding element. As will be appreciated more fully from the discussion below in connection with FIGS. 2-16, so deforming the fabric will reorient the relative positions of the strands of the metal fabric from their initial order to a second, reoriented configuration. The shape of the molding element should be selected to deform the fabric into substantially the shape of the desired medical device.

The molding element can be a single piece, or it can be formed of a series of mold pieces which together define the surface to which the fabric will generally conform. The molding element can be positioned within a space enclosed by the fabric or can be external of such a space, or can even be both inside and outside such a space.

In order to illustrate one example of how such a mold may be configured and how it may be used in accordance with the method of the invention, reference will be had to FIGS. 2-5.

In FIGS. 2–4, the molding element **20** is formed of a number of separate pieces which can be attached to one another to complete the molding element **20**. In using such a multi-piece molding element, the mold can be assembled about the cut length of fabric **10**, thereby deforming the fabric to generally conform to the desired surface (or surfaces) of the molding element.

In the molding element illustrated in FIGS. 2–4, the metal fabric **10** is deformed to generally conform to a surface of the molding element **20**, the molding element comprising a center section **30** and a pair of end plates **40**. Turning first to the center section **30**, the center section is desirably formed of opposed halves **32**, **32** which can be moved away from one another in order to introduce the metal fabric **10** into the mold. Although these two halves **32**, **32** are shown in the drawings as being completely separated from one another, it is to be understood that these halves could be interconnected, such as by means of a hinge or the like, if so desired. The opposed halves of the molding element **20** shown in the drawings of FIGS. 2 and 3 each include a pair of semi-circular recesses opposed on either side of a ridge defining a generally semi-circular opening. When the two halves are assembled in forming the device, as best seen in FIG. 3, the semi-circular openings in the opposed halves **32**, **32** mate to define a generally circular forming port **36** passing through the center section **30**. Similarly, the semi-circular recesses in the two halves together form a pair of generally circular central recesses **34**, with one such recess being disposed on either face of the center section.

The overall shape and dimensions of the center section can be varied as desired; it is generally the size of the central recesses **34** and the forming port **36** which will define the size and shape of the middle of the finished device, as explained below. If so desired, each half **32** may be provided with a manually graspable projection **38**. In the embodiment shown in the drawings, this projection **38** is provided at a location disposed away from the abutting faces of the respective halves. Such a manually graspable projection **38** will simply enable an operator to more easily join the two halves to define the recesses **34** and forming port **36**.

The center section is adapted to cooperatively engage a pair of end plates **40** for forming the desired device. In the embodiment shown in FIGS. 2 and 3, the center section **30** has a pair of flat outer faces **39** which are each adapted to be engaged by an inner face **42** of one of the two end plates **40**. Each end plate includes a compression disk **44** which extends generally laterally inwardly from the inner face **42** of the end plate. This compression disk **44** should be sized to permit it to be received within one of the central recesses **34** on either face of the center section **30**. For reasons explained more fully below, each compression disk **44** includes a cavity **46** for receiving an end of the length of the metal fabric **10**.

One or more channels **48** for receiving bolts and the like may also be provided through each of the end plates and through the center section **30**. By passing bolts through these channels **48**, one can assemble the molding element **20** and retain the metal fabric in the desired shape during the heat treatment process, as outlined below.

In utilizing the molding element **20** shown in FIGS. 2–4, a length of the metal fabric **10** can be positioned between the opposed halves **32** of the center section **30**. In the drawings of the molding element **20** of FIGS. 2–4, the metal fabric **10** is a tubular braid such as that illustrated in FIG. 1A. A sufficient length of the tubular braid should be provided to permit the fabric to conform to the molding surface, as

explained below. Also, as noted above, care should be taken to secure the ends of the wire strands defining the tubular braid in order to prevent the metal fabric from unraveling.

A central portion of the length of the metal braid may be positioned within one of the two halves of the forming port **36** and the opposed halves **32** of the center section may be joined to abut one another to restrain a central portion of the metal braid within the central forming port **36** through the center section.

The tubular braid will tend to have a natural, relaxed diameter which is defined, in large part, when the tubular braid is formed. Unless the tubular braid is otherwise deformed, when the wire strands are in their relaxed state they will tend to define a generally hollow tube having the predetermined diameter. The outer diameter of the relaxed braid may be, for example, about 4 mm. The relative size of the forming port **36** in the center section **30** of the molding element and the natural, relaxed outer diameter of the tubular braid may be varied as desired to achieve the desired shape of the medical device being formed.

In the embodiment shown in FIGS. 2 and 3, the inner diameter of the forming port **36** is optimally slightly less than the natural, relaxed outer diameter of the tubular braid **10**. Hence, when the two halves **32**, **32** are assembled to form the center section **30**, the tubular braid **10** will be slightly compressed within the forming port **36**. This will help ensure that the tubular braid conforms to the inner surface of the forming port **36**, which defines a portion of the molding surface of the molding element **20**.

If so desired, a generally cylindrical internal molding section (not shown) may also be provided. This internal molding section has a slightly smaller diameter than the inner diameter of the forming port **36**. In use, the internal molding section is placed within the length of the metal fabric, such as by manually moving the wire strands of the fabric apart to form an opening through which the internal molding section can be passed. This internal molding section should be positioned within the tubular braid at a location where it will be disposed within the forming port **36** of the center section when the molding element is assembled. There should be a sufficient space between the outer surface of the interior molding section and the inner surface of the forming port **36** to permit the wire strands of the fabric **10** to be received therebetween.

By using such an internal molding section, the dimensions of the central portion of the finished medical device can be fairly accurately controlled. Such an internal molding section may be necessary in circumstances where the natural, relaxed outer diameter of the tubular braid **10** is less than the inner diameter of the forming port **36** to ensure that the braid conforms to the inner surface of that forming port. However, it is not believed that such an internal molding section would be necessary if the natural, relaxed outer diameter of the braid were larger than the inner diameter of the forming port **36**.

As noted above, the ends of the tubular braid should be secured in order to prevent the braid from unraveling. Each end of the metal fabric **10** is desirably received within a cavity **46** formed in one of the two end plates **40**. If a clamp (**15** in FIG. 2) is used, the clamp may be sized to be relatively snugly received within one of these cavities **46** in order to effectively attach the end of the fabric to the end plate **40**. The end plates can then be urged toward the center section **30** and toward one another until the compression disk **44** of each end plate is received within a central recess **34** of the center section **30**. The molding element may then



be clamped in position by passing bolts or the like through the channels **48** in the molding element and locking the various components of the molding element together by tightening a nut down onto such a bolt (not shown).

As best seen in FIG. **3A**, when an end plate is urged toward the center section **30**, this will compress the tubular braid **10** generally along its axis. When the tubular braid is in its relaxed configuration, as illustrated in FIG. **1A**, the wire strands forming the tubular braid will have a first, predetermined relative orientation with respect to one another. As the tubular braid is compressed along its axis, the fabric will tend to flare out away from the axis, as illustrated in FIG. **4**. When the fabric is so deformed, the relative orientation of the wire strands of the metal fabric will change. When the molding element is finally assembled, the metal fabric will generally conform to the molding surface of this element.

In the molding element **20** shown in FIGS. **2-4**, the molding surface is defined by the inner surface of the forming port, the inner surfaces of the central recess **34** and the faces of the compression disks **44** which are received within the recesses **34**. If an internal molding section is used, the cylindrical outer surface of that section may also be considered a part of the molding surface of the molding element **20**. Accordingly, when the molding element **20** is completely assembled the metal fabric will tend to assume a somewhat "dumbbell"-shaped configuration, with a relatively narrow center section disposed between a pair of bulbous, perhaps even disk-shaped end sections, as best seen in FIG. **4**.

It should be understood that the specific shape of the particular molding element **20** shown in FIGS. **2-4** is intended to produce one useful medical device in accordance with the present method, but that other molding elements having different configurations could also be used. If a more complex shape is desired, the molding element may have more parts, but if a simpler shape is being formed the molding element may have even fewer parts. The number of parts in a given molding element and the shapes of those parts will be dictated almost entirely by the shape of the desired medical device as the molding element must define a molding surface to which the metal fabric will generally conform.

Accordingly, the specific molding element **20** shown in FIGS. **2-4** is simply intended as one specific example of a suitable molding element for forming one particular useful medical device. Additional molding elements having different designs for producing different medical devices are explained below in connection with, e.g., FIGS. **8** and **10**. Depending on the desired shape of the medical device being formed, the shape and configuration of other specific molding elements can be readily designed by those of ordinary skill in the art.

Once the molding element **20** is assembled with the metal fabric generally conforming to a molding surface of that element, the fabric can be subjected to a heat treatment while it remains in contact with that molding surface. This heat treatment will depend in large part upon the material of which the wire strands of the metal fabric are formed, but the time and temperature of the heat treatment should be selected to substantially set the fabric in its deformed state, i.e., wherein the wire strands are in their reoriented relative configuration and the fabric generally conforms to the molding surface.

The time and temperature of the heat treatment can vary greatly depending upon the material used in forming the

wire strands. As noted above, one preferred class of materials for forming the wire strands are shape memory alloys, with nitinol, a nickel titanium alloy, being particularly preferred. If nitinol is used in making the wire strands of the fabric, the wire strands will tend to be very elastic when the metal is in its austenitic phase; this very elastic phase is frequently referred to as a "superelastic" or "pseudoelastic" phase. By heating the nitinol above a certain phase transition temperature, the crystal structure of the nitinol metal when in its austenitic phase can be set. This will tend to "set" the shape of the fabric and the relative configuration of the wire strands in the positions in which they are held during the heat treatment.

Suitable heat treatments of nitinol wire to set a desired shape are well known in the art. Spirally wound nitinol coils, for example, are used in a number of medical applications, such as in forming the coils commonly carried around distal lengths of guidewires. A wide body of knowledge exists for forming nitinol in such medical devices, so there is no need to go into great detail here on the parameters of a heat treatment for the nitinol fabric preferred for use in the present invention.

Briefly, though, it has been found that holding a nitinol fabric at about 500° C. to about 550° C. for a period of about 1 to about 30 minutes, depending on the softness or hardness of the device to be made, will tend to set the fabric in its deformed state, i.e. wherein it conforms to the molding surface of the molding element. At lower temperatures the heat treatment time will tend to be greater (e.g. about one hour at about 350° C.) and at higher temperatures the time will tend to be shorter (e.g. about 30 seconds at about 900° C.). These parameters can be varied as necessary to accommodate variations in the exact composition of the nitinol, prior heat treatment of the nitinol, the desired properties of the nitinol in the finished article, and other factors which will be well known to those skilled in this field.

Instead of relying on convection heating or the like, it is also known in the art to apply an electrical current to the nitinol to heat it. In the present invention, this can be accomplished by, for example, hooking electrodes to the clamps **15** carried at either end of the metal fabric illustrated in FIG. **2**. The wire can then be heated by resistance heating of the wires in order to achieve the desired heat treatment, which will tend to eliminate the need to heat the entire molding element to the desired heat treating temperature in order to heat the metal fabric to the desired temperature.

After the heat treatment, the fabric is removed from contact with the molding element and will substantially retain its shape in a deformed state. When the molding element **20** illustrated in FIGS. **2-4** is used, the bolts (not shown) may be removed and the various parts of the molding element may be disassembled in essentially the reverse of the process of assembling the molding element. If an internal molding section is used, this molding section can be removed in much the same fashion that it is placed within the generally tubular metal fabric in assembling the molding element **20**, as detailed above.

FIGS. **5A** and **5B** illustrate one embodiment of a medical device **60** which may be made using the molding element **20** of FIGS. **2-4**. As discussed below, the device of FIG. **5** is particularly well suited for use in occluding a channel within a patient's body and these designs have particular advantages in use as vascular occlusion devices.

The vascular occlusion device **60** of FIG. **5A** includes a generally tubular middle portion **62** and a pair of expanded diameter portions **64**. One expanded diameter portion is

disposed at either end of the generally tubular middle portion **62**. In the embodiment shown in FIGS. **5A** and **5B**, the expanded diameter portions **64** include a ridge **66** positioned about midway along their lengths.

The relative sizes of the tubular middle section and the expanded diameter portions can be varied as desired. In this particular embodiment, the medical device is intended to be used as a vascular occlusion device to substantially stop the flow of blood through a patient's blood vessel. When the device **60** is deployed within a patient's blood vessel, as detailed below, it will be positioned within the vessel such that its axis generally coincides with the axis of the vessel. The dumbbell-shape of the present device is intended to limit the ability of the vascular occlusion device **60** to turn at an angle with respect to the axis of the blood vessel to ensure that it remains in substantially the same position in which the operator deploys it within the vessel.

Although the illustrated embodiments of this invention only have two expanded diameter portions, it should be understood that the device could have more than two such expanded diameter portions. For example, if the device has three expanded diameter portions, each expanded diameter portion is separated from at least one other expanded diameter portion by a tubular portion having a smaller diameter. If so desired, the diameters of each of the expanded diameter portions can be the same but they need not be the same.

In order to relatively strongly engage the lumen of the blood vessel, the a maximum diameter of the expanded diameter portions **64** (which occurs along the middle ridge **66** in this embodiment) should be selected so that it is at least as great as the diameter of the lumen of the vessel in which it is to be deployed, and is optimally slightly greater than that diameter. When it is deployed within the patient's vessel, the vascular occlusion device **60** will engage the lumen at two spaced-apart locations. The device **60** is desirably longer along its axis than the dimension of its greatest diameter. This will substantially prevent the vascular occlusion device **60** from turning within the lumen at an angle to its axis, essentially preventing the device from becoming dislodged and tumbling along the vessel with blood flowing through the vessel.

The relative sizes of the generally tubular middle portion **62** and expanded diameter portion **64** of the vascular occlusion device **60** can be varied as desired for any particular application. For example, the outer diameter of the middle portion **62** may range between about one quarter and about one third of the maximum diameter of the expanded diameter portions **64** and the length of the middle portion **62** may comprise about 20% to about 50% of the overall length of the device. Although these dimensions are suitable if the device **60** is to be used solely for occluding a vascular vessel, it is to be understood that these dimensions may be varied if the device is to be used in other applications, such as where the device is intended to be used simply as a vascular filter rather than to substantially occlude the entire vessel or where the device is deployed in a different channel in a patient's body.

The aspect ratio (i.e., the ratio of the length of the device over its maximum diameter or width) of the device **60** illustrated in FIGS. **5A** and **5B** is desirably at least about 1.0, with a range of about 1.0 to about 3.0 being preferred and an aspect ratio of about 2.0 being particularly preferred. Having a greater aspect ratio will tend to prevent the device from rotating generally perpendicularly to its axis, which may be referred to as an end over end roll. So long as the outer diameter of the expanded diameter portions **64** of the device

is large enough to seat the device fairly securely against the lumen of the channel in which the device is deployed, the inability of the device to turn end over end will help keep the device deployed precisely where it is positioned within the patient's vascular system or in any other channel in the patient's body. Alternatively, having expanded diameter portions which have natural, relaxed diameters substantially larger than the lumen of the vessels in which the device is deployed should also suffice to wedge the device into place in the vessel without undue concern being placed on the aspect ratio of the device.

The pick and pitch of the metal fabric **10** used in forming the device **60**, as well as some other factors such as the number of wires employed in a tubular braid, are important in determining a number of the properties of the device. For example, the greater the pick and pitch of the fabric, and hence the greater the density of the wire strands in the fabric, the stiffer the device will be. Having a greater wire density will also provide the device with a greater wire surface area, which will generally enhance the tendency of the device to occlude a blood vessel in which it is deployed. This thrombogenicity can be either enhanced, e.g. by a coating of a thrombolytic agent or by attaching silk or wool fabric to the device, or abated, e.g. by a coating of a lubricious, anti-thrombogenic compound. A variety of materials and techniques for enhancing or reducing thrombogenicity are well known in the art and need not be detailed here.

When the device is deployed in a patient's vessel, thrombi will tend to collect on the surface of the wires. By having a greater wire density, the total surface area of the wires will be increased, increasing the thrombolytic activity of the device and permitting it to relatively rapidly occlude the vessel in which it is deployed. It is believed that forming the occlusion device **60** from a 4 mm diameter tubular braid having a pick of at least about 40 and a pitch of at least about 30° will provide sufficient surface area to substantially completely occlude a blood vessel of 2 mm to about 4 mm in inner diameter in a suitable period of time. If it is desired to increase the rate at which the device **60** occludes the vessel in which it is deployed, any of a wide variety of known thrombolytic agents can be applied to the device.

FIGS. **6A–6C** illustrate an alternative embodiment of a medical device in accordance with the present invention. This device **80** has a generally bell-shaped body **82** and an outwardly extending forward end **84**. One application for which this device is particularly well suited is occluding defects known in the art as patent ductus arteriosus (PDA). PDA is essentially a condition wherein two blood vessels, most commonly the aorta and pulmonary artery adjacent the heart, have a shunt between their lumens. Blood can flow directly between these two blood vessels through the shunt, compromising the normal flow of blood through the patient's vessels.

As explained more fully below in connection with FIG. **8**, the bell-shaped body **82** is adapted to be deployed within the shunt between the vessels, while the forward end **84** is adapted to be positioned within one of the two vessels to help seat the body in the shunt. The sizes of the body **82** and the end **84** can be varied as desired for differently sized shunts. For example, the body may have a diameter along its generally cylindrical middle **86** of about 10 mm and a length along its axis of about 25 mm. In such a device, the base **88** of the body may flare generally radially outward until it reaches an outer diameter equal to that of the forward end **84**, which may be on the order of about 20 mm in diameter.

The base **88** desirably flares out relatively rapidly to define a shoulder tapering radially outwardly from the

middle **86** of the body. When the device is deployed in a vessel, this shoulder will abut the lumen of one of the vessels being treated. The forward end **84** is retained within the vessel and urges the base **88** of the body open to ensure that the shoulder engages the wall of the vessel to prevent the device **80** from becoming dislodged from within the shunt.

As detailed above, in making a device of the invention it is desirable to attach the ends of the wire strands forming the metal fabric **10** to one another to prevent the fabric from unraveling. In the illustrations of FIGS. 6A–6C, a clamp **15** is used to tie together the ends of the wire strands adjacent the front end **84** of the device. It is to be understood that this clamp **15** is simply a schematic illustration, though, and that the ends could be attached in other ways, such as by welding, soldering, brazing, use of a biocompatible cementitious material or in any other suitable fashion.

The rearward ends of the wire strands are shown as being attached to one another by an alternative clamping means **90**. This clamp **90** serves the same purpose as the schematically illustrated clamp **15**, namely to interconnect the ends of the wires. However the clamp **90** also serves to connect the device **80** to a delivery system (not shown). In the embodiment shown, the clamp **90** is generally cylindrical in shape and has a recess for receiving the ends of the wires to substantially prevent the wires from moving relative to one another, and a threaded outer surface. The threaded outer surface is adapted to be received within a cylindrical recess (not shown) on a distal end of a delivery device and to engage the threaded inner surface of the delivery device's recess.

The delivery device (not shown) can take any suitable shape, but desirably comprises an elongate, flexible metal shaft having such a recess at its distal end. The delivery device can be used to urge the PDA occlusion device **80** through the lumen of a catheter for deployment in a channel of the patient's body, as outlined below. When the device is deployed out the distal end of the catheter, the device will still be retained by the delivery device. Once the proper position of the device **80** in the shunt is confirmed, the shaft of the delivery device can be rotated about its axis to unscrew the clamp **90** from the recess in the delivery means.

By keeping the PDA device **80** attached to the delivery means, the operator could still retract the device for repositioning if it is determined that the device is not properly positioned in the first attempt. This threaded attachment will also allow the operator to control the manner in which the device **80** is deployed out of the distal end of the catheter. As explained below, when the device exits the catheter it will tend to resiliently return to a preferred expanded shape which is set when the fabric is heat treated. When the device springs back into this shape, it may tend to act against the distal end of the catheter, effectively urging itself forward beyond the end of the catheter. This spring action could conceivably result in improper positioning of the device if the location of the device within a channel is critical, such as where it is being positioned in a shunt between two vessels. Since the threaded clamp **90** can enable the operator to maintain a hold on the device during deployment, the spring action of the device can be controlled and the operator can control the deployment to ensure proper positioning.

A PDA occlusion device **80** of this embodiment of the invention can advantageously be made in accordance with the method outlined above, namely deforming a metal fabric to generally conform to a molding surface of a molding element and heat treating the fabric to substantially set the fabric in its deformed state. FIG. 7 shows a molding element

**100** which may be suitable for forming a PDA occlusion device **80** such as that shown in FIGS. 6A–6C.

The molding element **100** generally comprises a body portion **110** and an end plate **120**. The body portion **110** is adapted to receive and form the body **82** of the device **80** while the end plate is adapted to compress against the metal fabric to form the forward end **84**. The body portion **110** includes an elongate, generally tubular central segment **112** which is sized to receive the elongate body **82** of the device. The central segment **112** of the molding element **100** optimally has an internal diameter slightly less than the natural, relaxed outer diameter of the tubular braid of which the device is formed. This compression of the braid will help yield devices with reproducibly sized bodies **82**. The forward end of the body portion **110** includes a back plate **114** which has a generally annular sidewall **116** depending downwardly therefrom. The sidewall defines a recess **118** which is generally circular in shape.

The end plate **120** of the molding element **100** has a generally disc-shaped face **122**, which desirably has a clamp port **124** approximately centered therein for receiving a clamp **15** attached to the metal fabric, as noted above. The end plate also has an annular sidewall **126** which extends generally upwardly from the face **122** to define a generally cylindrical recess **128** in the end plate **120**. The sidewall **116** of the body portion **110** is sized to be received within the recess **128** of the end plate.

In use, the metal fabric is placed in the molding element and the body portion **110** and the end plate **120** are brought toward one another. The inner face of the back plate **114** will engage the fabric and tend to urge it under compression generally radially outwardly. The fabric will then be enclosed generally within the recess **118** of the body portion and will generally conform to the inner surface of that recess. If one prevents the entire clamp **15** from passing through the clamp port **124**, the fabric will be spaced slightly away from the inner surface of the face **122**, yielding a slight dome shape in the forward end **84** of the device, as illustrated in FIGS. 6. Although the illustrated embodiment includes such a dome-shaped forward end, it is to be understood that the forward end may be substantially flat (except for the clamp **15**), which can be accomplished by allowing the clamp to be received entirely within the clamp port **124** in the end plate.

Once the fabric is compressed in the molding element **100** so that it generally conforms to the molding surface of the molding element, the fabric can be subjected to a heat treatment such as is outlined above. When the molding element is opened again by moving the body portion **110** and the end plate **120** away from one another again, the fabric will generally retain its deformed, compressed configuration. The device can then be collapsed, such as by urging the clamps **15**, **90** generally axially away from one another, which will tend to collapse the device toward its axis. The collapsed device **80** can then be passed through a catheter for deployment in a channel in a patient's vascular system.

FIG. 8 schematically illustrates how a medical device **80** generally as outlined above can be used to occlude a patent ductus arteriosus. In this case, there is a shunt, referred to as a PDA above, which extends between a patient's aorta A and the pulmonary artery P. The device **80** can be passed through the PDA, such as by keeping the device collapsed within a catheter (not shown), and the forward end **84** of the device can be allowed to elastically expand to substantially recover its thermally set, "remembered" shape from the heat treatment process, such as by urging the device distally to extend

beyond the distal end of the catheter. This forward end **84** should be larger than the lumen of the shunt of the PDA.

The device can then be retracted so that the forward end **84** engages the wall of the pulmonary artery P. If one continues to retract the catheter, the engagement of the device with the wall of the pulmonary artery will tend to naturally pull the body portion **82** of the device from the catheter, which will permit the body portion to return to its expanded configuration. The body portion should be sized so that it will frictionally engage the lumen of the PDA's shunt. The device **80** will then be held in place by the combination of the friction between the body portion and the lumen of the shunt and the engagement between the wall of the pulmonary artery and the forward end **84** of the device. Over a relatively short period of time, thrombi will form in and on the device **80** and the thrombi will occlude the PDA. If so desired, the device may be coated with a suitable thrombolytic agent to speed up the occlusion of the PDA.

FIGS. **9A** and **9B** are a side view and an end view, respectively, of yet another embodiment of the present invention. This device **180** can be used for a variety of applications in a patient's blood vessels. For example, if a fabric having a relatively high pick (i.e. where the wire density is fairly great) is used in making the device, the device can be used to occlude blood vessels. In other applications, it may serve as a filter within a channel of a patient's body, either in a blood vessel or in another channel, such as in a urinary tract or biliary duct. In order to further enhance or reduce the device's tendency to occlude the vessel, depending on the application of the device a suitable known thrombogenic or antithrombogenic coating may be applied to the device.

This filter **180** has a generally conical configuration, tapering generally radially outwardly from its rearward end **182** to its forward end **184**. A length of the device adjacent its forward end is adapted to engage the walls of a lumen of a channel. The maximum diameter of the filter device **180** is therefore at least as large as the inner diameter of the channel in which it is to be positioned so that at least the forward end will engage the wall of the vessel to substantially lock the device in place.

Having a series of unsecured ends **185** of the wire strands adjacent the forward end of the device will assist in seating the device in the channel because the ends of the wires will tend to dig into the vessel wall slightly as the forward end of the device urges itself toward its fully expanded configuration within the vessel. The combination of the friction between the outwardly urging forward end of the device and the tendency of the wire ends to dig into the vessel walls will help ensure that the device remains in place where it is deployed rather than floating freely within a vessel to reach an undesired location.

The method in which the device **180** of the invention is deployed may vary depending on the nature of the physiological condition to be treated. For example, in treating an arterio-venous fistula, the device may be carefully positioned, as described above, to occlude the flow of blood at a fairly specific location. In treating other conditions (e.g. an arterio-venous malformation), however, it may be desired to simply release a number of these devices upstream of the malformation in a vessel having a larger lumen and simply allow the devices to drift from the treatment site to lodge in smaller vessels downstream.

The decision as to whether the device **180** should be precisely positioned at an exact location within the channel in a patient's body or whether it is more desirable to allow

the device(s) to float to their final lodging site will depend on the size of the channels involved and the specific condition to be treated. This decision should be left to the individual operator to be made on a case-by-case basis as his or her experience dictates; there is no one right or wrong way to deploy the device **180** without regard to the conditions at hand.

In the embodiment shown in FIGS. **9A** and **9B**, the wall of the device extends generally linearly from a position adjacent the clamp **90** and the other end of the device, approximating a conical shape. Due to the presence of the clamp **90**, though, the end of the device immediately adjacent the clamp may deviate slightly from the cone shape, as indicated in the drawings. Alternatively, the wall may be curved so that the diameter of the device changes more rapidly adjacent the rearward end than it does adjacent its forward end, having an appearance more like a rotation of a parabola about its major axis than a true cone. Either of these embodiments should suffice in occluding a vessel with the device **180**, such as to occlude a vessel.

The ends of the wire strands at the rearward end **182** of the device are secured with respect to one another, such as by means of a threaded clamp **90** such as that described above in connection with FIGS. **6A-6C**. Portions of the wire strands adjacent the forward end **184** may also be secured against relative movement, such as by spot welding wires to one another where they cross adjacent the forward end. Such a spot weld is schematically illustrated at **186** in FIGS. **9A** and **9B**.

In the embodiment illustrated in FIGS. **9**, though, the ends of the wire strands adjacent the forward end **184** in the finished device need not be affixed to one another in any fashion. These strands are held in a fixed position during the forming process to prevent the metal fabric from unraveling before it is made into a finished device. While the ends of the wire strands adjacent the forward end remain fixed relative to one another, they can be heat treated, as outlined above. The heat treatment will tend to fix the shapes of the wires in their deformed configuration wherein the device generally conforms to a molding surface of the molding element. When the device is removed from contact with the molding element, the wires will retain their shape and tend to remain intertwined. Accordingly, when the device is released from contact with the molding element, even if the ends of the wires are released from any constraint the device should still substantially retain its shape.

FIGS. **10A-10C** illustrate three suitable molds for use in forming the filter **180** of FIGS. **9A** and **9B**. In FIG. **10A**, the molding element **200** is a single piece which defines a pair of generally conical portions abutting one another. In another similar embodiment (not shown), the molding element **200** may be generally ovoid, shaped not unlike an American football or a rugby ball. In the embodiment illustrated in FIG. **10A**, though, the molding element is a little bit less rounded. This molding element comprises two conical segments **202** which abut one another at their bases, defining a larger diameter at the middle **204** of the element which can taper relatively uniformly toward the ends **206** of the element **200**.

When a tubular braid is used in forming this device, the tubular metal fabric may be applied to the molding element by placing the molding element within the tubular braid and clamping the ends of the braid about the molding element before cutting the braid to the desired length. In order to better facilitate the attachment of the clamps **90** to the ends of the tubular braid, the ends **206** of the molding element

may be rounded, as shown, rather than tapering to a sharper point at the ends of the molding element. In order to ensure that the braid more closely conforms to the outer surface of the molding element **200**, i.e. the molding element's molding surface, the natural, relaxed diameter of the braid should be less than the maximum diameter of the element, which occurs at its middle **204**. This will place the metal fabric in tension about the middle of the element and, in combination with the clamps at the ends of the braid, cause the braid to generally conform to the molding surface.

FIG. **10B** illustrates an alternative molding element **210** for forming a device substantially as shown in FIGS. **9A** and **9B**. Whereas the molding **30** element **200** is intended to be received within a recess in the metal fabric, such as within the lumen of a length of tubular braid, the molding element **210** has an internal cavity **212** adapted to receive the fabric. In this embodiment, the molding element may comprise a pair of molding sections **214**, **216** and these mold sections may be substantially identical in shape. Each of the molding sections **214**, **216** generally comprise a conical inner surface **220** defined by a wall **222**. Each section also may be provided with a generally cylindrical axial recess **224** for receiving a clamp **15** (or **90**) carried by an end of the metal fabric.

The two molding sections should be readily attached to one another with the larger, open ends **226** of the sections abutting one another. The mold sections can simply be clamped together, such as by providing a reusable jig (not shown) which can be used to properly position the sections **214**, **216** with respect to one another. If so desired, bolt holes **228** or the like may be provided to allow a nut and bolt, or any similar attachment system, to be passed through the holes and attach the sections **214**, **216** together.

In use, a suitably sized piece of a metal fabric, optimally a length of a tubular braid, is placed in the recess **212** of the molding element and the two molding sections **214**, **216** are urged toward one another. The fabric should have a relaxed axial length longer than the axial length of the recess **212** so that bringing the sections toward one another will axially compress the fabric. This axial compression will tend to urge the wire strands of the braid radially outwardly away from the axis of the braid and toward engagement with the molding surface of the element **210**, which is defined by the surface of the recess **212**.

Once the metal fabric is deformed to generally conform to the molding surface of either molding element **200** or **210**, the fabric can be heat treated to substantially set the shape of the fabric in its deformed state. If molding element **200** is used, it can then be removed from the interior of the metal fabric. If there is sufficient room between the resilient wire strands, the molding element can simply be removed by opening the web of wire strands and pulling the molding element out of the interior of the metal fabric. If molding element **210** is employed, the two molding sections **214**, **216** can be moved away from one another and the molded fabric can be retrieved from the recess **212**. Depending on the shape of the molding surface, the resulting formed shape may resemble either a pair of abutting hollow cones or, as noted above, a football, with clamps, welds or the like provided at either end of the shape.

This shape can then be cut into two halves by cutting the wires in a direction generally perpendicular to the shared axis of the cones (or the major axis of the ovoid shape) at a location about midway along its length. This will produce two separate filter devices **180** substantially as illustrated in FIGS. **9A** and **9B**. If the wire strands are to be joined

adjacent the forward end of the device (such as by the weldments shown as **186** in FIGS. **9A** and **9B**), this can be done before the conical or ovoid shape is severed into two halves. Much the same net shape could be accomplished by cutting the metal fabric into halves while it is still carried about molding element **200**. The separate halves having the desired shape could then be pulled apart from one another, leaving the molding element ready for forming additional devices.

In an alternative embodiment of this method, the molding element **200** is formed of a material selected to permit the molding element to be destroyed for removal from the interior of the metal fabric. For example, the molding element may be formed of a brittle or friable material, such as glass. Once the material has been heat treated in contact with the molding surface of the molding element, the molding element can be broken into smaller pieces which can be readily removed from within the metal fabric. If this material is glass, for example, the molding element and the metal fabric can be struck against a hard surface, causing the glass to shatter. The glass shards can then be removed from the enclosure of the metal fabric. The resultant shape can be used in its generally conical shape, or it can be cut into two separate halves to produce a device substantially as shown in FIGS. **9A** and **9B**.

Alternatively, the molding element **200** can be formed of a material which can be chemically dissolved, or otherwise broken down, by a chemical agent which will not substantially adversely affect the properties of the metal wire strands. For example, the molding element can be formed of a temperature-resistant plastic resin which is capable of being dissolved with a suitable organic solvent. The fabric and the molding element can be subjected to a heat treatment to substantially set the shape of the fabric in conformance with the surface of the molding element, whereupon the molding element and the metal fabric can be immersed in the solvent. Once the molding element is substantially dissolved, the metal fabric can be removed and either used in its current shape or cut into separate halves, as outlined above.

Care should be taken to ensure that the material selected to form the molding element is capable of withstanding the heat treatment without losing its shape, at least until the shape of the fabric has been set. For example, the molding element could be formed of a material having a melting point above the temperature necessary to set the shape of the wire strands, but below the melting point of the metal forming the strands. The molding element and metal fabric can then be heat treated to set the shape of the metal fabric, whereupon the temperature can be increased to substantially completely melt the molding element, thereby removing the molding element from within the metal fabric.

It should be understood that the methods outlined immediately above for removing the metal fabric **10** from the molding element **200** can be used in connection with other shapes, as well. Although these methods may not be necessary or desirable if the molding element is carried about the exterior of the metal fabric (such as are elements **30-40** of the molding element **20** of FIGS. **2-4**), if the molding element or some portion thereof is enclosed within the formed metal fabric (such as the internal molding section of the molding element **20**), these methods can be used to effectively remove the molding element without adversely affecting the medical device being formed.

FIG. **10C** illustrates yet another molding element **230** which can be used in forming a medical device such as that

illustrated in FIGS. 9A and 9B. This molding element comprises an outer molding section 232 defining a tapered inner surface 234 and an inner molding section 236 having an outer surface 238 substantially the same shape as the tapered inner surface 234 of the outer molding section. The inner molding section 236 should be sized to be received within the outer molding section, with a piece of the metal fabric (not shown) being disposed between the inner and outer molding sections. The molding surface of this molding element 230, to which the fabric will generally conform, can be considered to include both the inner surface 234 of the outer molding section and the outer surface 238 of the inner molding section.

This molding element 230 can be used with a metal fabric which is in the form of a tubular braid. If such a fabric is used and a clamp 15 (not shown in this drawing) or the like is provided to connect the ends of the wire strands adjacent one end of the device, a recess (not shown) analogous to the cavity 46 in the face of the compression disk 44 of molding element 20 (FIGS. 2-4) can be provided for receiving the clamp.

However, the present molding element 230 can be used quite readily with a flat woven piece of metal fabric, such as is illustrated in FIG. 1B. In using such a fabric, a suitably sized and shaped piece of fabric is cut; in using the molding element 230 to produce a device 180 analogous to that shown in FIGS. 9A and 9B, for example, a generally disk-shaped piece of the metal fabric 10' can be used. The metal fabric is then placed between the two sections 232, 236 of the molding element and the sections are moved together to deform the fabric therebetween. After heat treatment, the fabric can be removed and will retain substantially the same shape as it had when it was deformed between the two molding sections.

As can be seen by the discussion of the various molding elements 200, 210 and 230 in FIGS. 10A-10C, it should be clear that a number of different molding elements may achieve essentially the same desired shape. These molding elements may be received entirely within a closed segment of fabric and rely on tension and/or compression of the fabric to cause it to generally conform to the molding surface of the molding element, as with the element 200 of FIG. 10A. The molding element 210 of FIG. 10B substantially encloses the fabric within a recess in the mold and relies on compression of the fabric (in this case axial compression of a tubular braid) to deform the fabric to the desired configuration. Finally, the fabric may be compressed between two coacting parts of the molding element to deform the fabric, such as between the two sections 232, 236 of molding element 230 in FIG. 10C. Any one or more of these techniques may be used in achieving a finished product having a desired shape.

FIGS. 11 and 12 illustrate alternative embodiments of yet another medical device in accordance with this invention. Both FIG. 11 and FIG. 12 illustrate a vascular trap suitable for use in temporarily filtering embolic particles from blood passing through a patient's vascular system. Such a device will most frequently be used to filter emboli from a patient's blood when another medical procedure is being performed, such as by using the trap in conjunction with a rotating cutting blade during an atherectomy or with a balloon catheter during angioplasty. It is to be understood, though, that the trap could also be used in other similar applications, such as in channels in patients' bodies other than their vascular systems.

In the embodiment of FIGS. 11A and 11B, the vascular trap 250 comprises a generally umbrella-shaped basket 270

carried adjacent a distal end of a guidewire 260. The guidewire in this embodiment includes a tapered distal section 262 with a spirally wound coil 264 extending along a distal length of the wire. Guidewires having such a distal end are conventional in the art. The basket 270 is positioned generally proximally of the coil 264, and is desirably attached to the guidewire proximally of the proximal end of the tapered section, as shown.

The basket 270 (shown in its collapsed configuration in FIG. 11A) includes a distal band 272 and a proximal band 274. The distal band may be made of a radiopaque material, such as gold, platinum or tungsten, and is affixed directly to the shaft of the guidewire 260. This attachment may be made by any suitable means, such as by welding, brazing, or soldering. Alternatively, the distal band 272 may comprise a bead of a biocompatible cementitious material, such as a curable organic resin. If it is desired to increase the visibility of the band for fluoroscopic observation, a radiopaque metal or the like can be imbedded in the cementitious material. The proximal band 274 may be formed of a hypotube sized to permit the tube to slide along the guidewire during deployment. This hypotube may be made of a metallic material; a thin-walled tube of a NiTi alloy should suffice. If so desired, the proximal band may be formed of a more radiopaque metal, or a NiTi alloy band can have a radiopaque coating applied to its surface.

The body of the device is formed of a metal fabric, as explained above. The metal fabric of this embodiment is optimally initially formed as a tubular braid and the ends of the wires forming the braid can be attached together by means of the bands 272, 274 before the fabric is cut to length. Much like the clamps 15, 90 noted above, these bands 272, 274 will help prevent the metal fabric from unraveling during the forming process. (The method of forming the basket 270 is described below in connection with FIG. 16.)

When the device is in its collapsed state for deployment in a patient's vessel (as illustrated in FIG. 11A), the basket 270 will be collapsed toward the axis of the guidewire 260. The distal 272 and proximal 274 bands are spaced away from one another along the length of the guidewire, with the fabric of the device extending therebetween. In a preferred embodiment, when the basket is in its collapsed state it will engage the outer surface of the guidewire to permit the device to be deployed through a relatively small lumen of a catheter or another medical device.

When the device is deployed in a patient's vascular system, the basket will take on an expanded configuration wherein it extends outwardly of the outer surface of the guidewire. As best seen in FIG. 11B, the shape of the basket 270 when deployed may generally resemble a conventional umbrella or parachute, having a dome-like structure curving radially outwardly from the guidewire moving proximally from the distal band 272. It is to be understood that other suitable shapes could easily perform the desired filtering function, such as a conical shape wherein the slope of the device changes more linearly than the smooth, rounded version shown in FIG. 11B. It is also believed that a relatively flat, disc shape would also suffice. In this expanded configuration, the two bands 272, 274 are closer together, with the distal band 272 optimally being spaced only a short distance from the proximal band 274, as illustrated.

In moving from its collapsed state (FIG. 11A) to its expanded state (FIG. 11B), the metal fabric turns in on itself, with a proximal portion 282 of the collapsed basket being

received within the interior of a distal portion **284** of the collapsed basket. This produces a two-layered structure having a proximal lip **286** spaced radially outwardly of the guidewire, defining a proximally-facing cupshaped cavity **288** of the basket. When blood (or any other fluid) flows through the basket in a distal direction, any particulate matter in the blood, e.g. emboli released into the blood-stream during atherectomy or angioplasty procedures, will tend to be trapped in the cavity **288** of the basket.

The precise dimensions of the metal fabric can be varied as desired for various applications. If the device **250** is to be used as a vascular filter to trap emboli released into the blood, for example, the pores (i.e. the openings between the crossing metal strands) of the fabric are desirably on the order of about 1.0 mm. This is generally deemed to be the minimum size of any particles which are likely to cause any adverse side effects if they are allowed to float freely within a blood vessel. One would not want to make the pores too small, though, because the blood (or other fluid) should be free to pass through the wall of the basket **270**. If so desired, the basket may be coated with a suitable anti-thrombogenic coating to prevent the basket from occluding a blood vessel in which it is deployed.

When a fabric having 1.0 mm pores is used to form the basket **270** of this embodiment of the invention, the forming process will reorient the wires relative to one another and in some areas (e.g. adjacent the proximal lip **286**) the pores will be larger than 1.0 mm. However, because the basket's walls are formed of essentially two thicknesses **282**, **284** of the fabric, the effective pore size of the device may be significantly reduced even at these locations.

The device **250** may also be provided with tethers **290** for collapsing the basket **270** during retraction. The basket may include four independent tether wires, each of which extends proximally from the proximal lip **286** of the deployed basket. In a preferred embodiment, though, the four tether wires illustrated in the drawings are actually formed of two longer wires, with each wire extending peripherally about a portion of the proximal lip of the basket. These tether wires may be intertwined with the wires of the metal fabric to keep the tethers in place during use. When the tethers are retracted or drawn down toward the guidewire, the wires extending along the proximal lip of the basket will tend to act as drawstrings, drawing the proximal end of the basket radially inwardly toward the guidewire. This will tend to close the basket and entrap any material caught in the cavity **288** of the basket during use so that the basket can be retracted, as detailed below.

The tether wires **290** may extend along much of the length of the guidewire so that they will extend outside the patient's body during use of the device **250**. When it is desired to collapse the basket for retrieval, the operator can simply hold the guidewire **260** steady and retract the tethers with respect to the guidewire. This can tend to be relatively cumbersome, though, and may be too difficult to effectively accomplish without breaking the tethers if the device is deployed at a selective site reached by a tortuous path, such as in the brain.

Accordingly, in the preferred embodiment shown in FIGS. **11A** and **11B**, the tethers **290** are attached to the guidewire **260** at a position spaced proximally of the basket. The tethers may, for example, be attached to a metal strap **292** or the like and this strap **292** may be affixed to the shaft of the guidewire. When it is desired to close the proximal end of the basket for retraction, an external catheter (not shown) can be urged distally toward the basket **270**. When

the catheter encounters the radially extending tethers, the distal end of the catheter will tend to draw the tethers toward the guidewire as the catheter is advanced, which will, in turn, tend to draw the proximal end of the basket closed.

FIGS. **12A** and **12B** illustrate an alternative embodiment of the device shown in FIGS. **11A** and **11B**, with FIG. **12A** showing the device collapsed in a catheter **C** for deployment and FIG. **12B** showing the device in its deployed configuration. In the embodiment shown in FIGS. **12A** and **12B**, the basket **270** is formed substantially the same as outlined above in connection with FIGS. **11A** and **11B**. In the embodiment of FIGS. **12**, though, the distal band **272** is affixed to the guidewire **260'** at the distal tip of the guidewire. The guidewire **260'** is of the type referred to in the art as a "movable core" guidewire. In such guidewires, a core wire **265** is received within the lumen of a helically wound wire coil **266** and the core wire **265** extends distally beyond the distal end of the coil **266**. A thin, elongate safety wire **268** may extend along the entire lumen of the coil **266** and the distal end of the safety wire may be attached to the distal end of the coil to prevent loss of a segment of the coil if the coil should break.

In the embodiment of FIG. **11**, the proximal ends of the tethers **290** are attached to a metal strap **292** which is itself attached to the shaft of the guidewire **260**. In the present embodiment, the tethers are not attached to the core wire **265** itself. Instead, the tethers are attached to the coil **266** of the guidewire. The tethers may be attached to the coil by any suitable means, such as by means of laser spot welding, soldering or brazing. The tethers **290** may be attached to the coil **266** at virtually any spot along the length of the coil. As illustrated in these drawings, for example, the tethers may be attached to the coil adjacent the coil's distal end. However, if so desired the tethers may be attached to the coil at a location spaced more proximally from the basket **270**.

An external catheter such as that referred to in the discussion of FIG. **11A**, but not shown in those drawings, is illustrated in FIGS. **12A** and **12B**. Once the basket **270** is deployed in a patient's vessel to substantially reach the expanded configuration shown in FIG. **12B** and the basket has performed its intended filtration function, the external catheter **C** can be urged distally toward the basket **270**. As this catheter is urged forward, the tethers will tend to be drawn into the distal end of the catheter, which is substantially narrower than the proximal lip **286** of the basket. This will tend to draw the tethers down toward the guidewire and help close the basket, as explained above.

FIGS. **13–15** illustrate yet another alternative embodiment of a vascular trap in accordance with the present invention. This vascular trap **300** includes a basket **320** received over a guidewire **310**. In most respects, the basket **320** is directly analogous to the basket **270** illustrated in FIGS. **11–12**. The basket **320** includes a proximal band **324** and a distal band **322**. As in the embodiment of FIGS. **12A** and **12B**, the distal band may be attached to the guidewire adjacent its distal end. If so desired, though, a structure such as is shown in FIG. **11**, wherein the guidewire extends distally beyond the basket, could instead be used.

As best seen in its collapsed state (shown in FIG. **13**), the basket includes a distal segment **325** and a proximal segment **326**, with the distal end of the distal segment being attached to the distal band **322** and the proximal end of the proximal segment being attached to the proximal band **324**. When the basket **320** is in the expanded configuration (shown in FIG. **14**), the proximal segment **326** is received within the distal segment **325**, defining a proximal lip **328** at the proximal

edge of the device. The wall of the basket thus formed also includes a cavity 329 for trapping solids entrained in a fluid, such as emboli in a patient's blood stream.

The basket 320 of FIGS. 13–15 is also shaped a little bit differently than the basket 270 of the previous drawings. The primary difference between these two baskets is that the basket 320 is a little bit shorter along its axis than is the basket 270. This different basket shape is simply intended to illustrate that the basket of a vascular trap in accordance with the invention can have any of a wide variety of shapes and no particular significance should be attached to the slightly different shapes shown in the various drawings.

In the vascular traps 250 and 250' of FIGS. 11 and 12, respectively, tethers were used to draw down the proximal end of the basket 270 to close the basket for retraction. In the embodiment shown in FIGS. 13–15, though, the trap 300 includes a basket cover 340 positioned proximally of the basket 320. The basket cover may also be formed of a metallic tubular braid and is also adapted to be collapsed to lay generally along the outer surface of the guidewire 310. The cover 340 is not directly affixed to the guidewire at any point, though, but is instead intended to be slidable along the guidewire. As best seen in FIGS. 13 and 14 wherein the cover is in its collapsed state, the cover 340 includes a distal hypotube 342 and a proximal control hypotube 344, with the distal hypotube being attached to the distal end of the cover 340 and the proximal control hypotube 344 being attached to the proximal end of the cover.

The cover 340 is shown in its deployed, expanded configuration in FIG. 15. As shown in that figure, the cover has a similar structure to that of the basket 320, but is oriented to be open distally rather than proximally, as is the basket. As best seen in FIGS. 13 and 14 wherein the cover is in its collapsed state, the cover has a distal segment 352 and a proximal segment 354. When the cover is deployed by urging it distally out of the distal end of the deployment catheter C, the cover 340 will tend to resiliently return to its expanded configuration and the distal hypotube 342 will slide axially proximally along the guidewire toward the proximal control hypotube 344. This will invert the collapsed cover so that the distal section 352 is generally received within the proximal section 354, defining a distal lip 358 of the cover.

The proximal control hypotube 344 may extend along a substantial portion of the length of the catheter 310 so that it extends out of the patient's body when the device 300 is in place. By grasping the control hypotube and moving it relative to the guidewire 310, an operator can control the position of the cover 340 with respect to the basket 320, which is affixed to the guidewires. As explained in more detail below in connection with the use of the device 300, once the basket has been deployed and has been used to filter objects entrained in the fluid (e.g. emboli in blood), the cover 340 may be deployed and the trap may be drawn proximally toward the cover by moving the guidewire proximally with respect to the control hypotube 344.

The inner diameter of the distal lip 358 of the cover is desirably slightly larger than the outer diameter of the proximal lip 328 of the basket. Hence, when the basket is drawn proximally toward the cover it will be substantially enclosed therein. The cover will therefore tend to trap any emboli (not shown) or other particulate matter retained within the cavity 330 of the basket. A retrieval sheath S may then be urged distally to engage the outer surface of the cover 340. This will tend to cause the cover to collapse about the basket, tightly engaging the outer surface of the basket.

This somewhat collapsed structure can then be withdrawn from the patient's channel and removed from the patient's body. By enclosing the basket within the cover, the likelihood of any filtered debris within the basket being lost as the basket is retrieved will be substantially eliminated.

The guidewire and the metal fabric can be of any diameter suitable for the intended application of the vascular trap 250, 250' or 300. In a preferred embodiment, the guidewire is between about 0.014" and about 0.038" in diameter and the wires of the metal fabric used to form the basket (and the cover 340, if a cover is included) are between about 0.002" and about 0.006". The thickness of the metal bands (272, 274 or 322, 324) also is desirably in the range of about 0.002"–0.006".

In one particularly preferred embodiment intended to be used in narrower vessels such as those encountered in cerebral and coronary applications, the guidewire has an outer diameter of about 0.014" and the wires of the metal fabric are about 0.002" in diameter. The metal bands in this embodiment may also have a thickness of about 0.002" so that they will not be substantially wider than the collapsed basket. When the device is collapsed for deployment through a catheter, it will have an outer diameter of about 0.018", permitting the device to be used with catheters and other instruments adapted for use with a 0.018" guidewire.

FIG. 16 illustrates one embodiment of a molding element 370 which may be used in making a basket 270. Although the basket 320 and cover 340 of the trap 300 are shaped somewhat differently, an analogous molding element can be used for these portions of the trap 300 as well by simply modifying some of the dimensions of the molding element 370, but retaining the basic shape and structure of the molding element. It also should be understood that the molding element 370 is merely one possible molding element for forming a shape such as that of the basket 270 and that any one of a variety of different molding elements will be apparent to those skilled in the art, as noted above in connection with FIGS. 10A–C.

The molding element 370 has an outer molding section 372 defining a curved inner surface 374 and an inner molding section 376 having an outer surface 378 substantially the same shape as the curved inner surface 374 of the outer molding section. The inner molding section 376 should be sized to be received within the outer molding section, with a piece of the metal fabric (not shown) being disposed between the inner and outer molding sections. In a preferred embodiment, the inner surface 374 of the outer molding element and the outer surface 378 of the inner molding section each include a recess (375 and 379, respectively) for receiving an end of the braid. The molding surface of this molding element 370, to which the fabric will generally conform, can be considered to include both the inner surface 374 of the outer molding section and the outer surface 378 of the inner molding section.

In use, the two molding sections 372, 376 are spaced apart from one another and a length of a tubular braid of metal fabric (not shown in FIG. 16) is disposed between these molding sections. Optimally, one end of the fabric is placed in the recess 375 of the outer molding section and the other end of the fabric is placed in the recess 379 in the inner molding section. The inner and outer molding sections can then be urged generally toward one another. As the ends of the wire approach one another, the tubular braid will tend to invert upon itself and a surface of the tubular braid will generally conform to either the inner surface 374 of the outer molding section or the outer surface 378 of the inner



25

molding section, arriving at a shape analogous to that of the basket **270** of the traps **250**, **250'**. The two molding sections can then be locked in place with respect to one another and the metal fabric may be heat treated to set the wires in this deformed configuration.

The method in accordance with the present invention further includes a method of treating a physiological condition of a patient. In accordance with this method, a medical device suitable for treating the condition, which may be substantially in accordance with one of the embodiments outlined above, is selected. For example, if a patent ductus arteriosus is to be treated, the PDA occlusion device **80** of FIGS. **6A–6C** can be selected. Once the appropriate medical device is selected, a catheter may be positioned within a channel in a patient's body to place the distal end of the catheter adjacent the desired treatment site, such as immediately adjacent (or even within) the shunt of the PDA.

Medical devices made in accordance with the method of the invention outlined above have a preset expanded configuration and a collapsed configuration which allows the device to be passed through a catheter. The expanded configuration is generally defined by the shape of the medical fabric when it is deformed to generally conform to the molding surface of the molding element. Heat treating the metal fabric substantially sets the shapes of the wire strands in the reoriented relative positions when the fabric conforms to the molding surface. When the metal fabric is then removed from the molding element, the fabric may define a medical device in its preset expanded configuration.

The medical device can be collapsed into its collapsed configuration and inserted into the lumen of the catheter. The collapsed configuration of the device may be of any shape suitable for easy passage through the lumen of a catheter and proper deployment out the distal end of the catheter. For example, the devices shown in FIGS. **5** may have a relatively elongated collapsed configuration wherein the devices are stretched along their axes. This collapsed configuration can be achieved simply by stretching the device generally along its axis, e.g. by manually grasping the clamps **15** and pulling them apart, which will tend to collapse the expanded diameter portions **64** of the device **60** inwardly toward the device's axis. The PDA occlusion device **80** of FIG. **6** also operates in much the same fashion and can be collapsed into its collapsed configuration for insertion into the catheter by applying tension generally along the axis of the device. In this regard, these devices **60** and **80** are not unlike "Chinese handcuffs", which tend to constrict in diameter under axial tension.

Once the medical device is collapsed and inserted into the catheter, it may be urged along the lumen of the catheter toward the distal end of the catheter. This may be accomplished by using a guidewire or the like to abut against the device and urge it along the catheter. When the device begins to exit the distal end of the catheter, which is positioned adjacent the desired treatment site, it will tend to resiliently return substantially entirely to its preset expanded configuration. Superelastic alloys, such as nitinol, are particularly useful in this application because of their ability to readily return to a particular configuration after being elastically deformed to a great extent. Hence, simply urging the medical device out of the distal end of the catheter tends to properly deploy the device at the treatment site.

Although the device will tend to resiliently return to its initial expanded configuration (i.e. its shape prior to being collapsed for passage through the catheter), it should be understood that it may not always return entirely to that

26

shape. For example, the device **60** of FIG. **5** is intended to have a maximum outer diameter in its expanded configuration at least as large as and preferably larger than, the inner diameter of the lumen in which it is to be deployed. If such a device is deployed in a vessel having a small lumen, the lumen will prevent the device from completely returning to its expanded configuration. Nonetheless, the device would be properly deployed because it would engage the inner wall of the lumen to seat the device therein, as detailed above.

If the device is to be used to permanently occlude a channel in the patient's body, such as the devices **60** and **80** described above may be, one can simply retract the catheter and remove it from the patient's body. This will leave the medical device deployed in the patient's vascular system so that it may occlude the blood vessel or other channel in the patient's body. In some circumstances, the medical device may be attached to a delivery system in such a manner as to secure the device to the end of the delivery means, such as when the threaded clamp **90** shown in FIGS. **6** and **9** is attached to a distal end of the delivery means, as explained above. Before removing the catheter in such a system, it may be necessary to detach the medical device from the delivery means before removing the catheter and the delivery means.

The devices of FIGS. **11–15** may be deployed in much the same fashion outlined above. However, these devices **250**, **250'** and **300** are advantageously deployed for use in conjunction with another medical device and will most frequently be retracted from the patient's body after use.

For example, any one of these devices are suitable for use in conjunction with a balloon angioplasty procedure. In such procedures, catheters having inflatable balloons at their ends, referred to as balloon catheters, are positioned within a blood vessel so that the balloon is positioned within a stenosis. These balloons are positioned by tracking the balloon catheter along a guidewire or the like; the balloons typically have a central bore therethrough. Once the balloon is properly positioned, it is inflated and urges radially outwardly against the stenosis. This will tend to squeeze the stenosis against the walls of the vessel, improving patency of the vessel.

When the stenosis is treated in this fashion, though, there is a risk that some debris will break free and enter the blood flowing through the vessel. If left unchecked, this embolus can drift downstream and embolize a distal portion of the vessel. Depending on where the embolus comes to rest, the embolization can result in significant tissue or organ damage. This risk is particularly acute in cardiac and coronary applications because the embolization can result in a myocardial infarction or heart attack, and in neurovascular and interventional radiological procedures the embolization can lead to a stroke or damage to brain tissue.

In order to prevent, or at least substantially limit, such embolization, a vascular trap **250**, **250'** or **300** of the invention can be used with the balloon catheter. The device should be sized to permit it to be passed through the lumen of the particular balloon catheter to be used in the angioplasty.

In one embodiment of a method for using such a vascular trap, the trap is deployed first. The basket (**270** or **320**) of the trap will be guided to a position located downstream of the desired treatment site through an introduction catheter (e.g. the catheter **C** in FIGS. **12–15**). The basket is then urged distally beyond the end of the catheter, which will permit the basket to resiliently substantially return to its expanded configuration from its collapsed configuration within the catheter. Once the trap is in place, the balloon catheter can

be exchanged for the introduction catheter, and the balloon catheter can track the guidewire (260 or 310) of the vascular trap. The balloon can then be positioned within the stenosis and expanded, as outlined above. Once the angioplasty has been completed, the balloon can be deflated again and withdrawn proximally out of the patient.

In an alternative embodiment of the present method, the balloon catheter can be used to perform the same function as performed by the introduction catheter in the preceding embodiment. In this embodiment, the balloon catheter is positioned in the patient's vessel so that the distal end of the balloon catheter is located downstream of the stenosis. The vascular trap (250, 250' or 300) of the invention is then passed through the lumen of the balloon catheter and the basket is urged out of the distal end of the catheter. The basket will resiliently substantially return to its preferred expanded configuration, whereupon the balloon catheter can be retracted along the shaft of the device's guidewire until the balloon is properly positioned within the stenosis.

If so desired, the balloon catheter can instead be provided with a length of standard catheter extending distally beyond the distal end of the balloon. The balloon can then be positioned within the stenosis and the basket can be urged out of the distal end of the distal extension of the catheter. In such an embodiment, the length of the distal extension of the catheter should be sufficient to properly position the basket with respect to the balloon when the basket exits the distal end of the catheter. This will eliminate the need to perform the separate step of retracting the balloon into position within the stenosis after the basket is deployed. The balloon can then be expanded, deflated and withdrawn as described above.

Much the same procedure can be used to deploy a vascular trap of the invention for use in an atherectomy procedure. In such procedures, a cutting head is positioned at the distal end of an elongate, hollow shaft and the cutting head has a bore extending therethrough. The trap can be deployed in either of the methods outlined above, but it is anticipated that in most instances the first procedure will be used, i.e. the basket will be deployed with an introduction catheter, which will be removed so that the cutting device can be guided over the guidewire of the vascular trap. It should also be understood that the device 250, 250' and 300 could also be used in other medical procedures in other bodily channels besides a patient's vascular system.

Since the trap is positioned downstream of the stenosis, any debris released during the procedure will tend to drift distally toward the basket and be caught therein. In order to prevent any emboli from simply floating past the trap, it is preferred that the proximal lip (288 or 328) of the basket be at least as large as the lumen of the vessel. In a preferred embodiment, the natural dimension of the proximal lip (i.e. where the basket has fully returned to its expanded configuration) is somewhat greater than the vessel's inner diameter so that the basket will firmly engage the wall of the vessel.

The method of retracting the basket will depend on which embodiment of the vascular trap is used, namely whether or not the device includes a cover 340. The devices 250 or 250' of FIGS. 11 or 12, respectively, do not include such a cover. However, they do include tethers 290 which extend proximally from the proximal lip 288 of the basket to an attachment to the guidewire. In either of these embodiments, a retrieval catheter can be introduced over the guidewire and urged distally toward the basket. As explained above in connection with FIGS. 11 and 12, this will tend to draw the

tethers down toward the guidewire, effectively dosing the proximal end of the basket 270. Once the basket is sufficiently closed, such as when the proximal lip of the basket engages the distal tip of the retrieval catheter, the catheter and the vascular trap can be retracted together from the patient's body. By substantially closing the proximal end of the basket in such a fashion, any emboli which are captured in the basket when it is deployed can be retained within the basket until it is removed from the patient's body.

If so desired, a balloon catheter or like device can instead be used, with the balloon catheter being used to draw down the tethers 290 and collapse the basket. The vascular trap can then be withdrawn with the balloon catheter rather than having to separately introduce a removal catheter to remove the trap.

In withdrawing the embodiment illustrated in FIGS. 13-15, the cover 340 is positioned over the proximal lip of the basket before the vascular trap 300 is retracted.

Once the medical procedure is completed and any debris has been captured in the basket, the cover 340 is allowed to resiliently substantially return to its expanded configuration. Once it is deployed proximally of the basket, the basket 320 can be drawn proximally toward the cover 340 until it engages or is received within the cover, as noted above in connection with FIG. 15.

In actuality, the cover 340 may be unable to return to its full expanded configuration due to the confines of the vessel in which it is deployed. As explained previously, the cover 340 is desirably larger than the basket 320 so that the basket can be received within the cover. However, the basket is optimally sized to engage the walls of the vessel to prevent the unwanted passage of emboli or other debris around the edges of the basket. Accordingly, the distal lip 358 of the cover will engage the wall of the channel before it expands to its full size. The walls of most bodily channels, such as blood vessels, tend to be somewhat elastic, though. The cover 340 will therefore tend to urge harder against the wall of the vessel than the smaller basket and may stretch the vessel a little bit more than will the basket. In this fashion, the cover may still be able to expand to a dimension large enough to permit the basket to be received in the cavity 356 of the cover. If not, the distal lip 358 of the cover can simply be brought into close engagement with the proximal lip 328 of the basket to generally seal the basket.

Once the cover 340 is brought into engagement with the basket 320, whether by receiving the basket within the cover or, less preferably, by engaging the lips 358, 328 of the cover and the basket, the device can be withdrawn proximally from the patient's vascular system. The cover will tend to prevent any emboli caught in the basket during deployment from being inadvertently lost during withdrawal.

The vascular traps 250, 250' and 300 of the present invention therefore have distinct advantages over other vascular traps or filters currently known in the art. As explained above, most prior art traps are difficult and expensive to form and cannot be readily collapsed for retrieval. The present invention, though, provides a method for making the vascular traps 250, 250' and 300 which is both relatively inexpensive and less labor intensive, generally resulting in a more consistent product than prior art hand-forming methods. Furthermore, the structure of the device and the methods outlined above for removing the device will fairly reliably prevent the inadvertent dumping of trapped emboli back into the bloodstream while the device is being removed. Since most prior art traps and filters are much more difficult to use and are more likely to dump filtered

debris back into the bloodstream, the present invention can be substantially safer than these prior art systems.

While a preferred embodiment of the present invention has been described, it should be understood that various changes, adaptations and modifications may be made therein without departing from the spirit of the invention and the scope of the appended claims.

What is claimed is:

1. A device for filtering emboli from blood flowing through a lumen defined by the walls of a vessel comprising:

a guidewire;

a filter element carried on a distal portion of the guidewire, the filter element having a distal end, the guidewire extending to at least the distal end of the filter element, the filter element being expandable from a collapsed delivery configuration when the filter is constrained to an expanded deployed configuration when the filter element is unrestrained, the filter element having a shape in the expanded configuration which forms a cavity having a proximally facing opening defining a proximally facing lip; and

a plurality of retraction members, each retraction member having a distal portion which engages the proximally facing lip of the filter element and a proximal end connected to the guidewire and an intermediate portion between the proximal end and distal portion, the retraction members being configured such that when the intermediate portions of the retraction members are moved towards the guidewire the proximally facing lip of the filter element is drawn radially inwardly in the direction of the guidewire.

2. The device of claim 1 wherein the filter element is self-expandable.

3. The device of claim 1 further comprising means for expanding the filter element from the collapsed configuration to the expanded configuration.

4. The device of claim 3 wherein the means for expanding comprises the filter element being comprised of nitinol.

5. The device of claim 1 wherein the filter element is attached to the guidewire at a distal region of the guidewire.

6. The device of claim 1 wherein the distal end of the filter element is connected to a distal band which encircles the guidewire.

7. The device of claim 6 wherein the distal band is connected in a fixed position on the guidewire.

8. The device of claim 6 wherein the proximal end of the filter element is connected to a proximal band which encircles the guidewire.

9. The device of claim 8 wherein one of the proximal and distal bands is connected at a fixed position on the guidewire.

10. The device of claim 8 wherein the proximal band is slidably disposed about the guidewire.

11. The device of claim 8 wherein when the filter element is in the collapsed configuration the distal and proximal bands are spaced apart a first distance and when the filter element is in the expanded configuration the proximal and distal bands are spaced apart a second distance, the first distance being greater than the second distance.

12. The device of claim 1 wherein when the filter element is in the expanded configuration a proximal portion of the filter element is of sufficient size and shape to engage the wall of the vessel.

13. The device of claim 12 wherein the filter element has a shape in the expanded configuration which decreases in size from the proximal portion to the distal end of the filter element.

14. The device of claim 1 wherein the filter element comprises a metal mesh.

15. The device of claim 14 wherein the filter element comprises nitinol.

16. The device of claim 1 wherein the guidewire includes a flexible portion extending distally of the distal end of the filter element.

17. The device of claim 1 wherein the guidewire extends through the cavity to at least the distal end of the filter element.

18. The device of claim 1 wherein the guidewire comprises a solid material.

19. The device of claim 1 wherein the guidewire comprises metal.

20. The device of claim 1 wherein the guidewire comprises a tapered portion.

21. The device of claim 1 wherein the retraction members comprise a non-rigid material.

22. A device for filtering emboli from blood flowing through a lumen defined by the walls of a vessel comprising:

a filter element having a distal end, the filter element being expandable from a collapsed delivery configuration when the filter is constrained to an expanded deployed configuration when the filter element is unrestrained, the filter element having a shape in the expanded configuration which forms a cavity having a proximally facing opening defining a proximally facing lip; and

means for carrying the filter element, the carrying means extending to at least the distal end of the filter element; and

a plurality of retraction members, each retraction member having a distal portion which engages the proximally facing lip of the filter element and a proximal end connected to the carrying means and an intermediate portion between the proximal end and distal portion, the retraction members being configured such that when the intermediate portions of the retraction members are moved towards the carrying means the proximally facing lip of the filter element is drawn radially inwardly in the direction of the carrying means.

23. A device for filtering emboli comprising:

a guidewire;

a filter element carried on a distal portion of the guidewire, the filter element having a distal end, the guidewire extending to at least the distal end of the filter element, the filter element being expandable from a collapsed delivery configuration to an expanded deployed configuration, the filter element having a shape in the expanded configuration which forms a cavity having a proximally facing opening at a proximal end of the filter element, the filter element being collapsible from the expanded deployed configuration to a retrieval configuration, the proximally facing opening being substantially closed in the retrieval configuration; and

a plurality of retraction members, each retraction member having a distal end connected to engage the proximal end of the filter element in the expanded configuration and a proximal end connected to the guidewire and an intermediate portion between the proximal and distal ends of the retraction member, the retraction members being configured such that when the intermediate portions of the retraction members are moved towards the guidewire the filter element is collapsed from its expanded deployed configuration to its retrieval configuration.

31

24. The device of claim 23 wherein the filter element is self-expandable.

25. The device of claim 23 further comprising means for expanding the filter element from the collapsed configuration to the expanded configuration.

26. The device of claim 25 wherein the means for expanding comprises the filter element being comprised of nitinol.

27. The device of claim 23 wherein the filter element is attached to the guidewire at a distal region of the guidewire.

28. The device of claim 23 wherein the distal end of the filter element is connected to a distal band which encircles the guidewire.

29. The device of claim 28 wherein the distal band is connected at a fixed position on the guidewire.

30. The device of claim 28 wherein the proximal end of the filter element is connected to a proximal band which encircles the guidewire.

31. The device of claim 30 wherein one of the proximal and distal bands is connected at a fixed position on the guidewire.

32. The device of claim 30 wherein the proximal band is slidably disposed about the guidewire.

33. The device of claim 30 wherein when the filter element is in the collapsed configuration the distal and proximal bands are spaced apart a first distance and when the filter element is in the expanded configuration the proximal and distal bands are spaced apart a second distance, the first distance being greater than the second distance.

34. The device of claim 23 wherein when the filter element is in the expanded configuration a proximal portion of the filter element is of sufficient size and shape to engage the wall of the vessel.

35. The device of claim 34 wherein the filter element has a shape in the expanded configuration which decreases in size from the proximal portion to the distal end of the filter element.

36. The device of claim 23 wherein the filter element comprises a metal mesh.

37. The device of claim 36 wherein the filter element comprises nitinol.

38. The device of claim 23 wherein the guidewire includes a flexible portion extending distally of the distal end of the filter element.

39. The device of claim 23 wherein the guidewire extends through the cavity to at least the distal end of the filter element.

40. The device of claim 23 wherein the guidewire comprises a solid material.

41. The device of claim 23 wherein the guidewire comprises metal.

42. The device of claim 23 wherein the guidewire comprises a tapered portion.

43. The device of claim 23 wherein the retraction members comprise a non-rigid material.

44. A device for filtering emboli comprising:

a filter element having a distal end, the filter element being expandable from a collapsed delivery configuration to an expanded deployed configuration, the filter element having a shape in the expanded configuration which forms a cavity having a proximally facing opening at a proximal end of the filter element, the filter element being collapsible from the expanded deployed configuration to a retrieval configuration, the proximally facing opening being substantially closed in the retrieval configuration;

means for carrying the filter element, the carrying means extending to at least the distal end of the filter element; and

a plurality of retraction members, each retraction member having a distal end connected to engage the proximal

32

end of the filter element in the expanded configuration and a proximal end connected to the carrying means and an intermediate portion between the proximal and distal ends of the retraction member, the retraction members being configured such that when the intermediate portions of the retraction members are moved towards the carrying means the filter element is collapsed from its expanded deployed configuration to its retrieval configuration.

45. A device for filtering emboli comprising:  
a guidewire;

a filter element carried on a distal portion of the guidewire, the filter element having a distal end, the guidewire extending to at least the distal end of the filter element, the filter element being expandable from a collapsed delivery configuration to an expanded deployed configuration, the filter element having a shape in the expanded configuration which forms a cavity having a proximally facing opening at a proximal end of the filter element, the proximally facing opening having peripheral edge, the filter element being collapsible from the expanded deployed configuration to a retrieval configuration, the proximally facing opening being substantially closed in the retrieval configuration; and

at least one tether having a first end engaging the peripheral edge of the filter element and a second end attached to the guidewire, the at least one tether being configured such that when the tether is drawn inwardly toward the guidewire it will act as a drawstring to collapse the peripheral edge of the filter element toward the guidewire.

46. The device of claim 45 wherein the at least one tether comprises a wire having first and second ends, the first end of the wire engaging the peripheral edge of the filter element and the second end of the wire being attached to the guidewire.

47. The device of claim 45 wherein the at least one tether comprises a wire attached at each end to the guidewire and extending about the peripheral edge of the filter element.

48. A device for filtering emboli comprising:

a filter element having a distal end, the filter element being expandable from a collapsed delivery configuration to an expanded deployed configuration, the filter element having a shape in the expanded configuration which forms a cavity having a proximally facing opening at a proximal end of the filter element, the proximally facing opening having a peripheral edge, the filter element being collapsible from the expanded deployed configuration to a retrieval configuration, the proximally facing opening being substantially closed in the retrieval configuration;

means for carrying the filter element, the carrying means extending to at least the distal end of the filter element; and

at least one tether having a first end engaging the peripheral edge of the filter element and a second end attached to the carrying means, the at least one tether being configured such that when the tether is drawn inwardly toward the carrying means it will act as a drawstring to collapse the peripheral edge of the filter element toward the carrying means.

49. A method for filtering emboli from blood flowing through a lumen defined by the walls of a vessel at a desired location in the vessel comprising:

providing a guidewire;

providing a filter element carried on a distal portion of the guidewire, the filter element having a distal end, the

33

guidewire extending to at least the distal end of the filter element, the filter element being expandable from a collapsed delivery configuration when the filter element is constrained to an expanded deployed configuration when the filter element is unrestrained, the filter element having a shape in the expanded configuration which forms a cavity having proximally facing opening defined by a proximally facing lip;

providing a plurality of retraction members, each retraction member having a distal end which engages the proximally facing lip of the filter element and a proximal end connected to the guidewire and an intermediate portion between the proximal and distal ends, the retraction members being configured such that when the intermediate portions of the retraction members are moved towards the guidewire the proximally facing lip of the filter element is drawn radially inwardly in the direction of the guidewire;

advancing the guidewire and filter element in its collapsed delivery configuration through the vessel until the filter element is located at the desired location;

expanding the filter element to its expanded deployed configuration;

filtering emboli from blood flowing through the vessel with the filter;

moving the intermediate portions of the retraction members towards the guidewire to draw the proximally facing lip of the filter element radially inwardly in the direction of the guidewire until the proximally facing opening is substantially closed; and

withdrawing the guidewire and filter element from the vessel.

**50.** The method of claim **49** wherein the step of moving the distal ends of the retraction members comprises drawing the intermediate portions of the retraction members radially inwardly beginning at the proximal end of the retraction members and advancing distally towards the distal end of the retraction members.

**51.** A method for filtering emboli from blood flowing through a lumen defined by the walls of a vessel at a desired location in the vessel comprising:

providing a filter device including a filter element and means for carrying the filter element, the filter element having a distal end, the carrying means extending to at least the distal end of the filter element, the filter element being expandable from a collapsed delivery configuration when the filter element is constrained to an expanded deployed configuration when the filter element is unrestrained, the filter element having a shape in the expanded configuration which forms a cavity having proximally facing opening defined by a proximally facing lip;

providing a plurality of retraction members, each retraction member having a distal end which engages the proximally facing lip of the filter element and a proximal end connected to the carrying means and an intermediate portion between the proximal and distal ends, the retraction members being configured such that when the intermediate portions of the retraction members are moved towards the carrying means the proximally facing lip of the filter element is drawn radially inwardly in the direction of the carrying means;

advancing the carrying means and filter element in its collapsed delivery configuration through the vessel until the filter element is located at the desired location;

expanding the filter element to its expanded deployed configuration;

34

filtering emboli from blood flowing through the vessel with the filter;

moving the intermediate portions of the retraction members towards the carrying means to draw the proximally facing lip of the filter element radially inwardly in the direction of the carrying means until the proximally facing opening is substantially closed; and

withdrawing the carrying means and filter element from the vessel.

**52.** A method for filtering emboli from blood flowing through the lumen of a vessel at a desired location comprising:

providing a guidewire;

providing a filter element carried on a distal portion of the guidewire, the filter element having a distal end, the guidewire extending to at least the distal end of the filter element, the filter element being expandable from a collapsed delivery configuration to an expanded deployed configuration, the filter element having a shape in the expanded configuration which forms a cavity having a proximally facing opening at a proximal end of the filter element, the filter element being collapsible from the expanded deployed configuration to a retrieval configuration, the proximally facing opening being substantially closed in the retrieval configuration;

providing a plurality of retraction members, each retraction member having a distal end which engages the proximal end of the filter element in the expanded configuration and a proximal end connected to the guidewire and an intermediate portion between the proximal and distal ends, the retraction members being configured such that when the intermediate portions of the retraction members are moved towards the guidewire the filter element is collapsed from its expanded deployed configuration to its retrieval configuration;

advancing the guidewire and filter element in its collapsed delivery configuration through the vessel until the filter element is located at the desired location;

expanding the filter element to its expanded deployed configuration;

filtering emboli from blood flowing through the vessel with the filter;

moving the intermediate portions of the retraction members towards the guidewire to collapse the filter element from its expanded deployed configuration to its retrieval configuration; and

withdrawing the guidewire and filter element from the vessel.

**53.** A system for filtering emboli from blood flowing through a lumen defined by the walls of a vessel comprising:

a guidewire;

a filter element carried on a distal portion of the guidewire, the filter element having a distal end, the guidewire extending to at least the distal end of the filter element, the filter element being expandable from a collapsed delivery configuration when the filter is constrained to an expanded deployed configuration when the filter element is unrestrained, the filter element having a shape in the expanded configuration which forms a cavity having a proximally facing opening defined by a proximally facing lip;

a plurality of retraction members, each retraction member having a distal end which engages the proximally facing lip of the filter element and a proximal end connected to the guidewire and an intermediate portion between the proximal and distal ends of the retraction

**35**

member, the retraction members being configured such that when the intermediate portions of the retraction members are moved towards the guidewire the proximally facing lip of the filter element is drawn radially inwardly in the direction of the guidewire; and  
5 a retrieval catheter having a lumen sized to accommodate the guidewire and the retraction members, the retrieval catheter being slidable over the guidewire, the lumen of the retrieval catheter being sized such that when the

**36**

retrieval catheter is moved distally along the guidewire from the proximal ends of the retraction members towards the distal ends of the retraction members when the filter element is in the expanded deployed configuration the intermediate portions are drawn into the lumen of the retrieval catheter and the distal ends of the retraction members are moved towards the guidewire.

\* \* \* \* \*