



US007038741B2

(12) **United States Patent**
Lai et al.

(10) **Patent No.:** **US 7,038,741 B2**
(45) **Date of Patent:** **May 2, 2006**

(54) **LIQUID CRYSTAL MODULE COMPRISING FASTENERS FOR FLEXIBLE CIRCUIT BOARD**

(75) Inventors: **Ching-Kun Lai**, Changhua (TW);
Mei-Hui Lin, Yung Ho (TW);
Chung-Te Lee, Hsinchu (TW)

(73) Assignee: **Hannstar Display Corporation**, Taipei (TW)

(*) Notice: Subject to any disclaimer, the term of this patent is extended or adjusted under 35 U.S.C. 154(b) by 88 days.

(21) Appl. No.: **10/671,386**

(22) Filed: **Sep. 25, 2003**

(65) **Prior Publication Data**

US 2004/0169782 A1 Sep. 2, 2004

(30) **Foreign Application Priority Data**

Feb. 27, 2003 (TW) 92203109 U

(51) **Int. Cl.**
G02F 1/1333 (2006.01)

(52) **U.S. Cl.** **349/58; 349/60**

(58) **Field of Classification Search** 349/5,
349/58, 60, 6, 150
See application file for complete search history.

(56) **References Cited**

U.S. PATENT DOCUMENTS

5,537,177 A * 7/1996 Terunuma 396/281
6,154,261 A * 11/2000 Shim 349/58
6,295,103 B1 * 9/2001 Yamatani et al. 349/58
6,686,979 B1 * 2/2004 Yoshino 349/58

* cited by examiner

Primary Examiner—Andrew Schechter
Assistant Examiner—Thoi V. Duong

(57) **ABSTRACT**

A frame structure and a grounding structure of a liquid crystal module are disclosed. The frame structure is adapted for fixedly securing a flexible printed circuit board and a control printed circuit board on the frame, wherein the flexible printed circuit board is electrically connected to a liquid crystal display panel and the control printed circuit board is electrically connected to the flexible printed circuit board. The grounding structure is adapted for fixedly securing a grounding copper foil on a metal bezel.

8 Claims, 6 Drawing Sheets

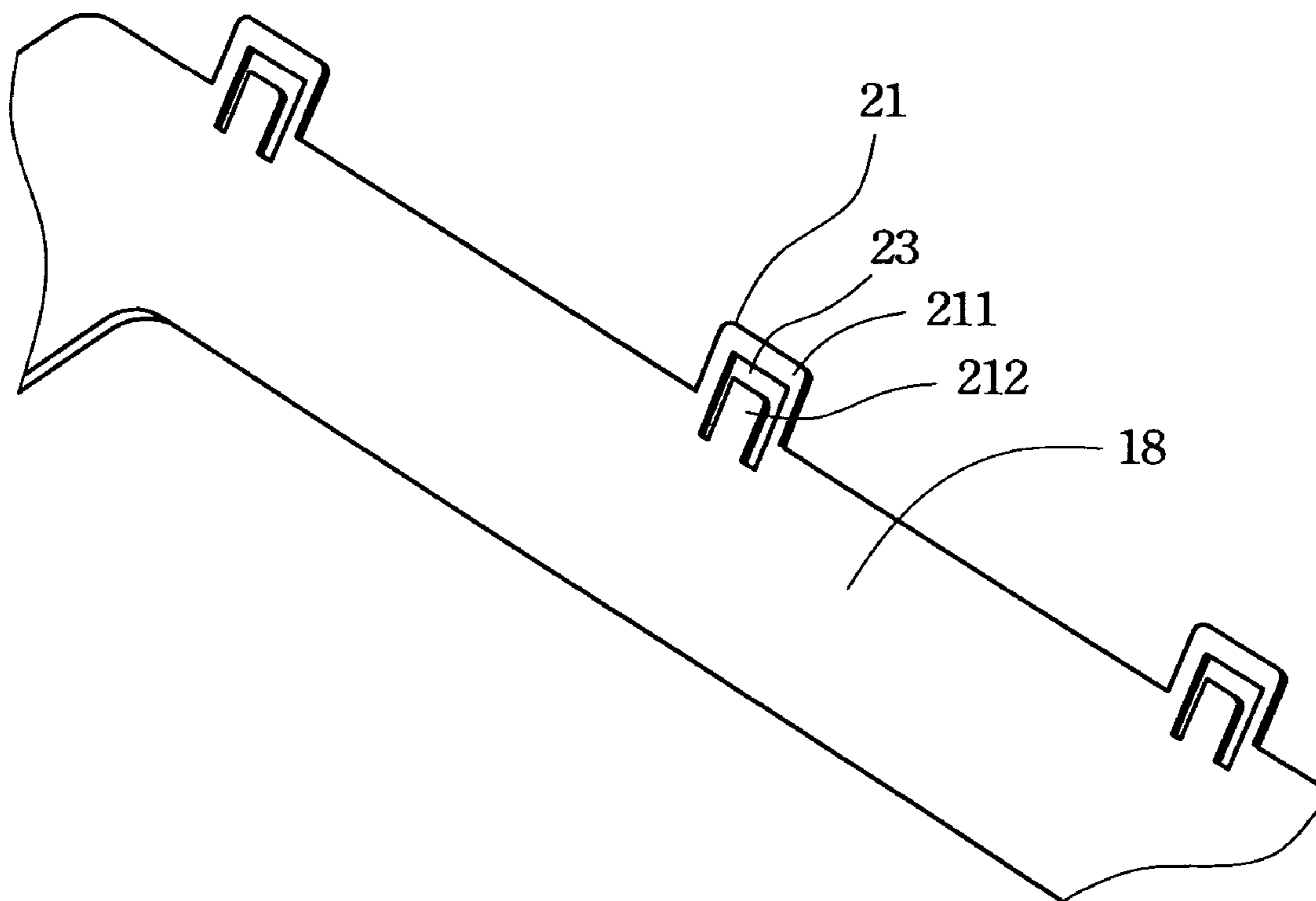

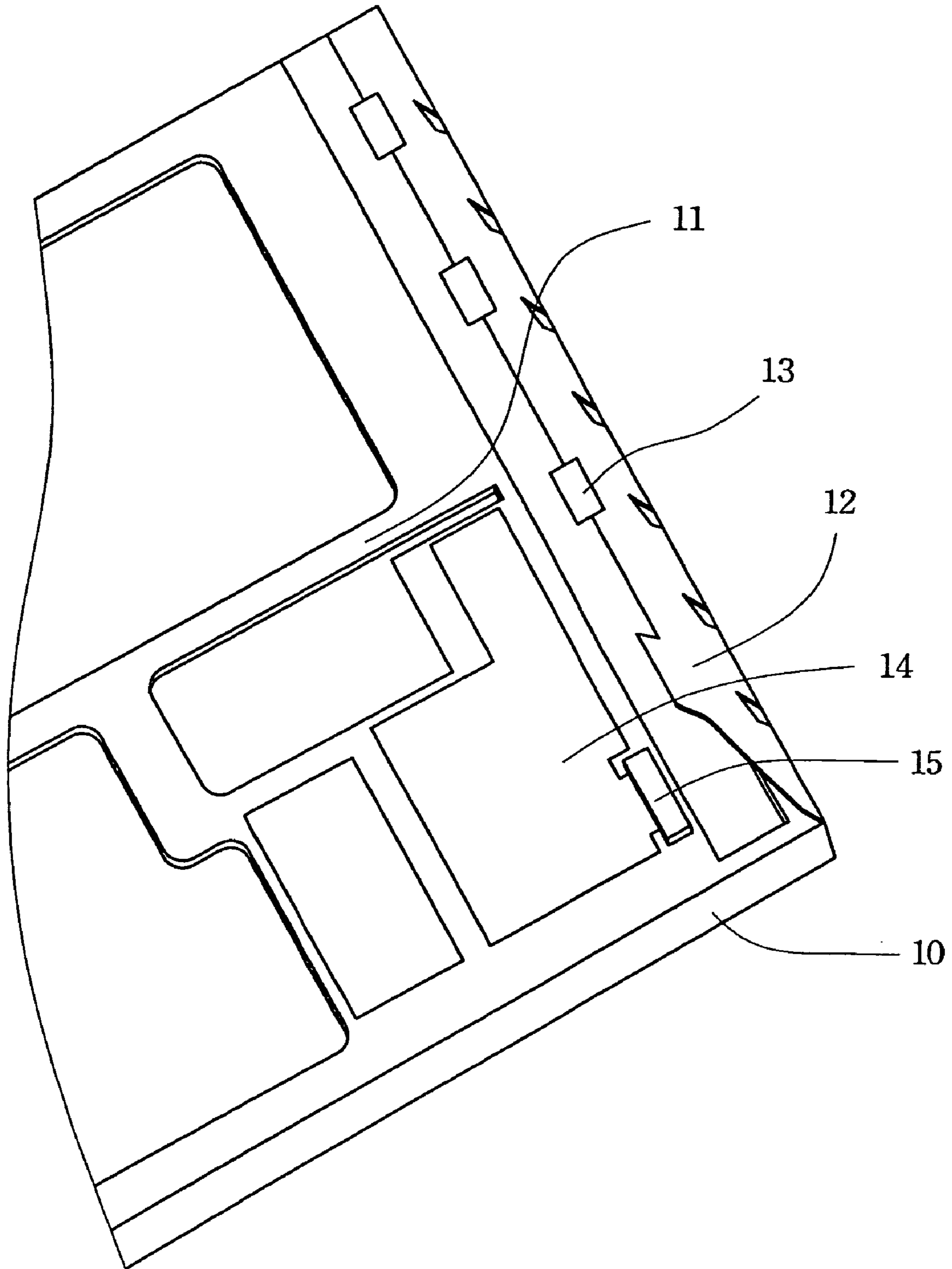

Fig. 1 (PRIOR ART)

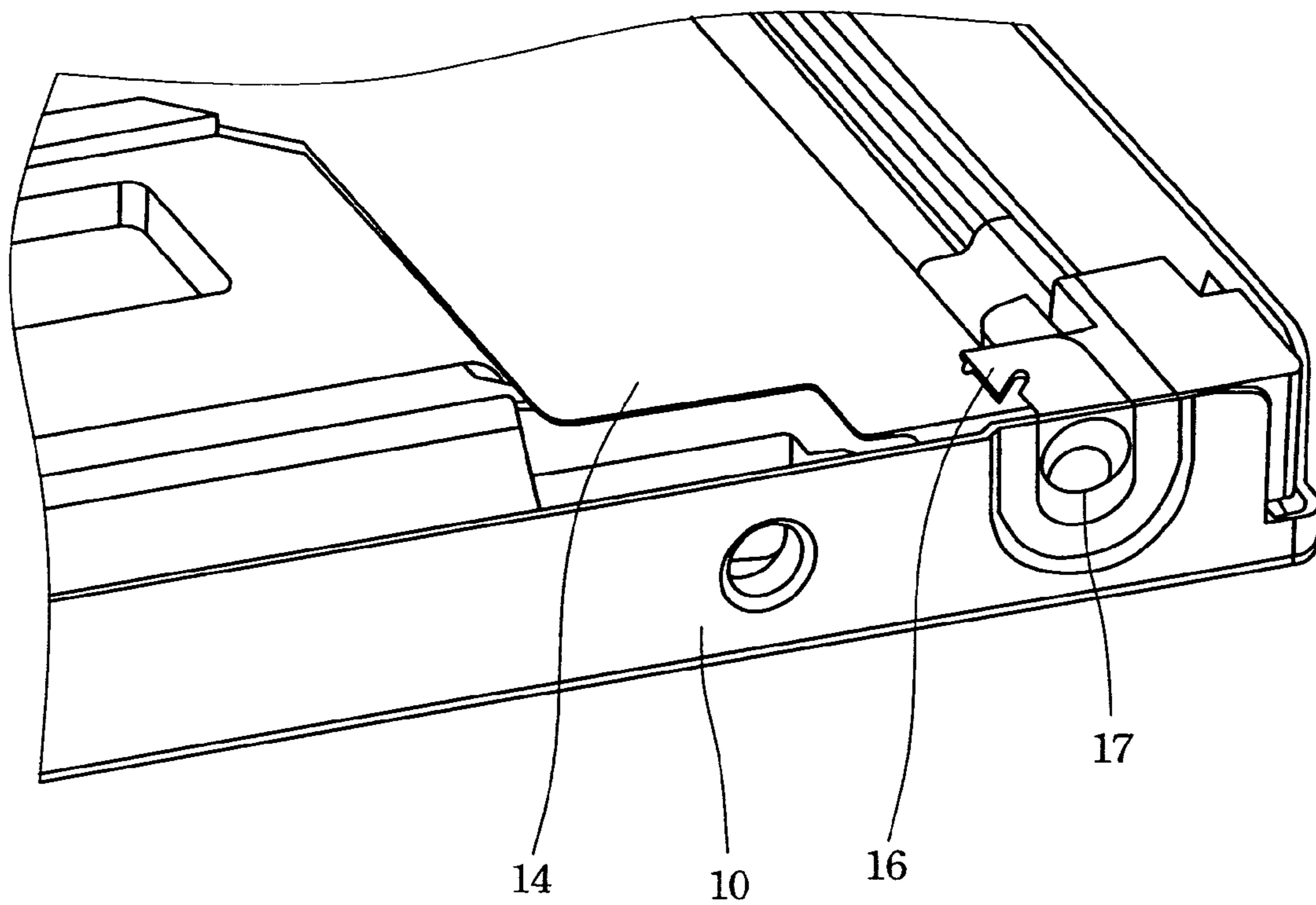

Fig. 2 (PRIOR ART)

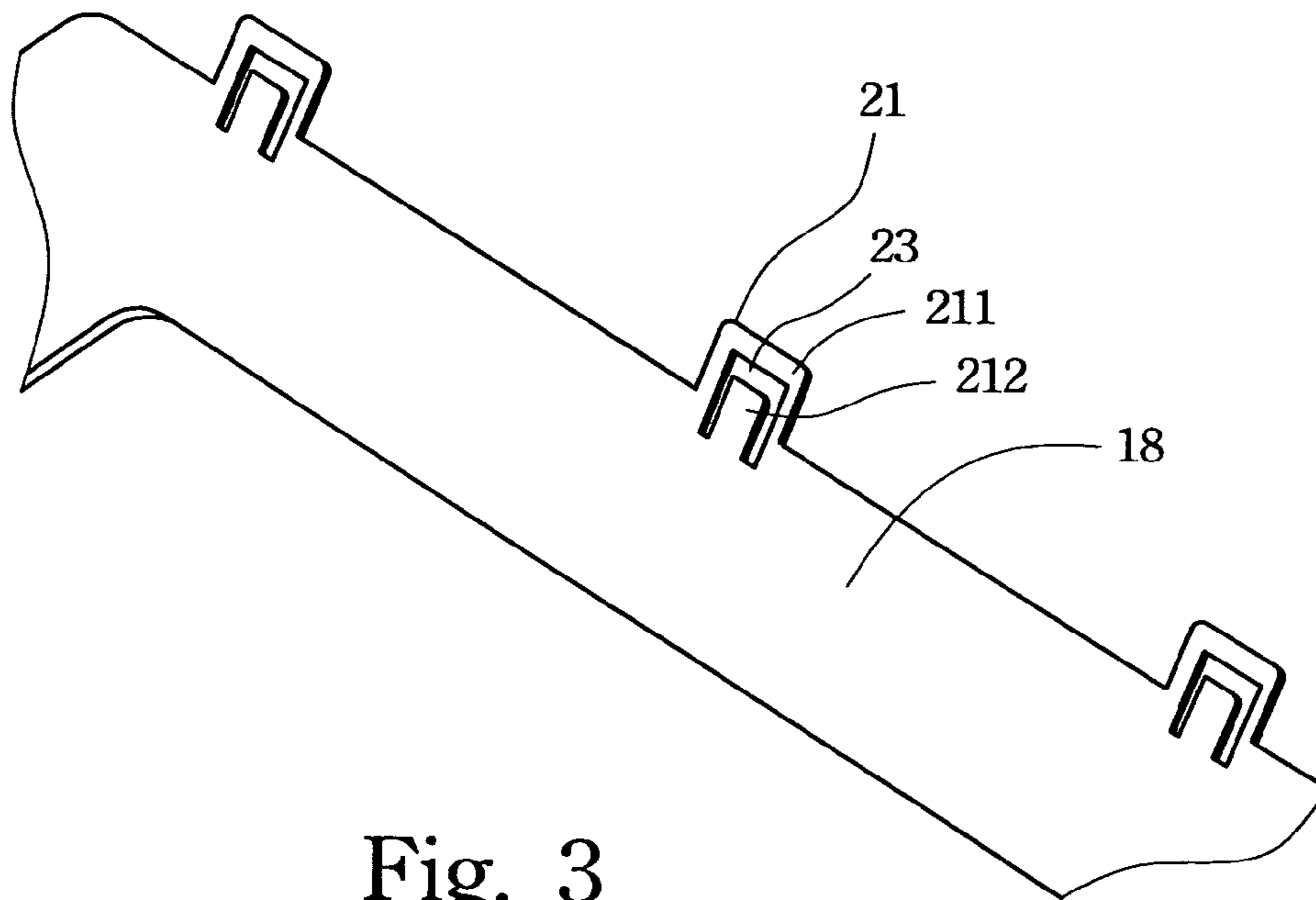

Fig. 3

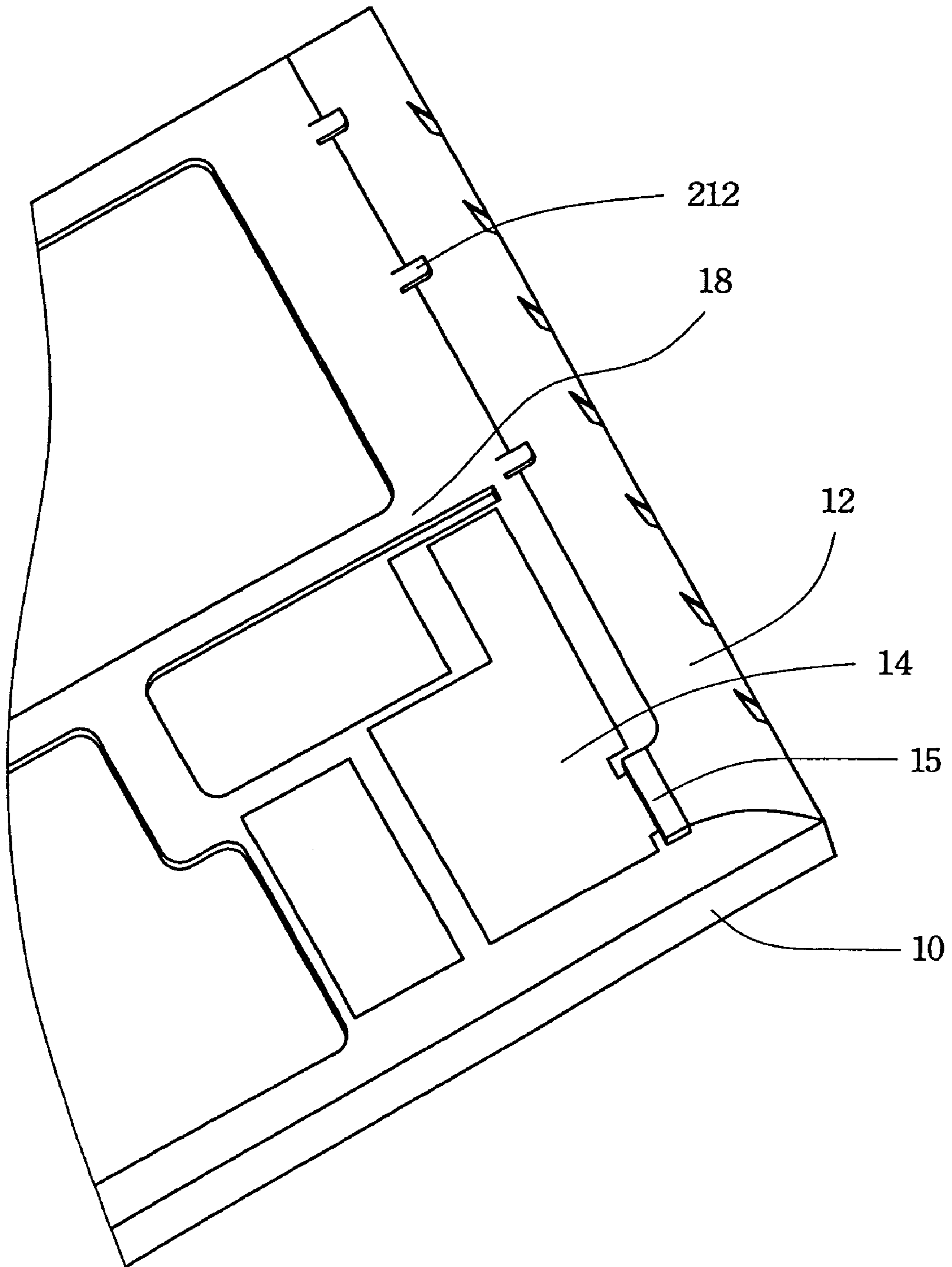

Fig. 4

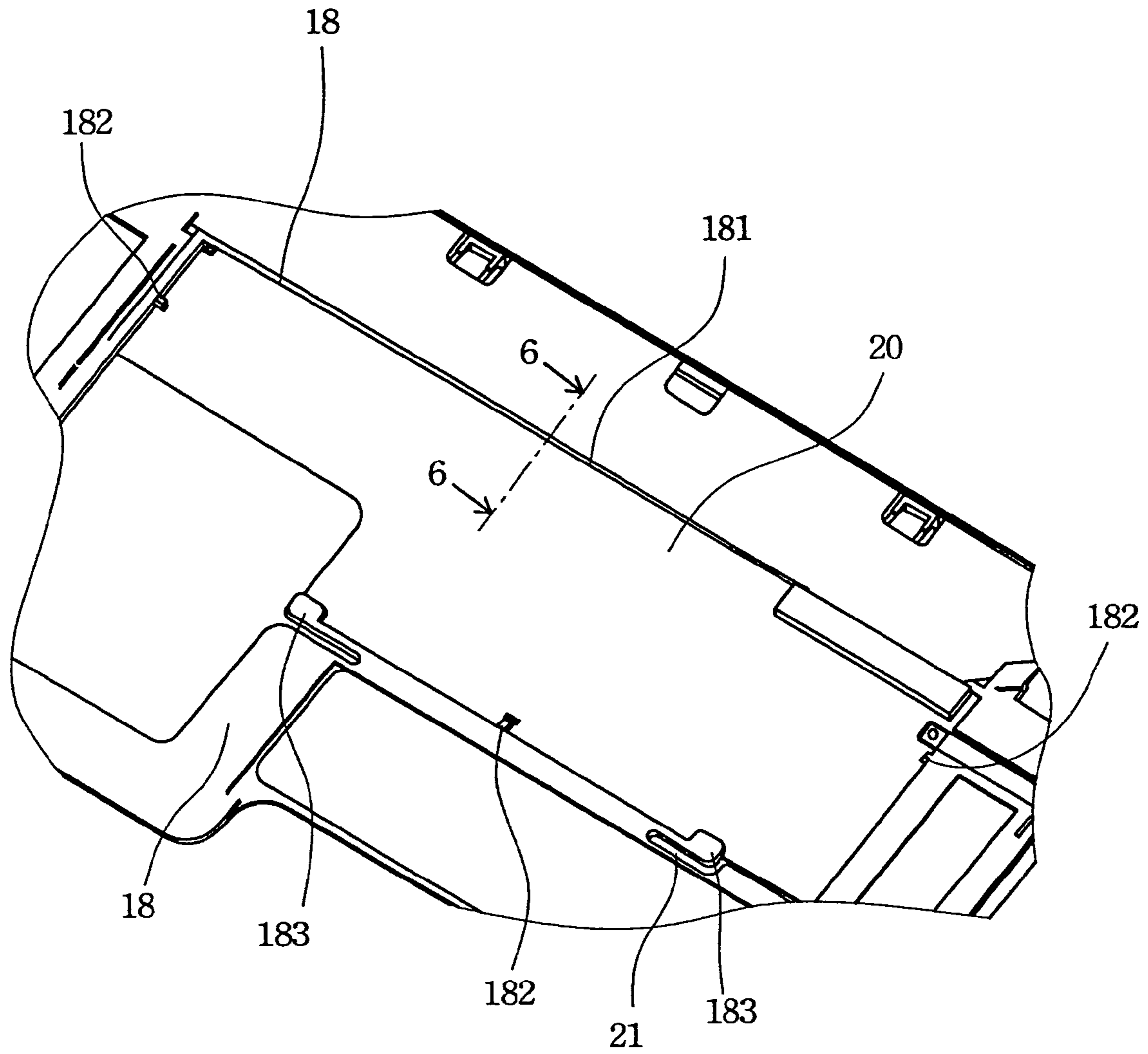

Fig. 5

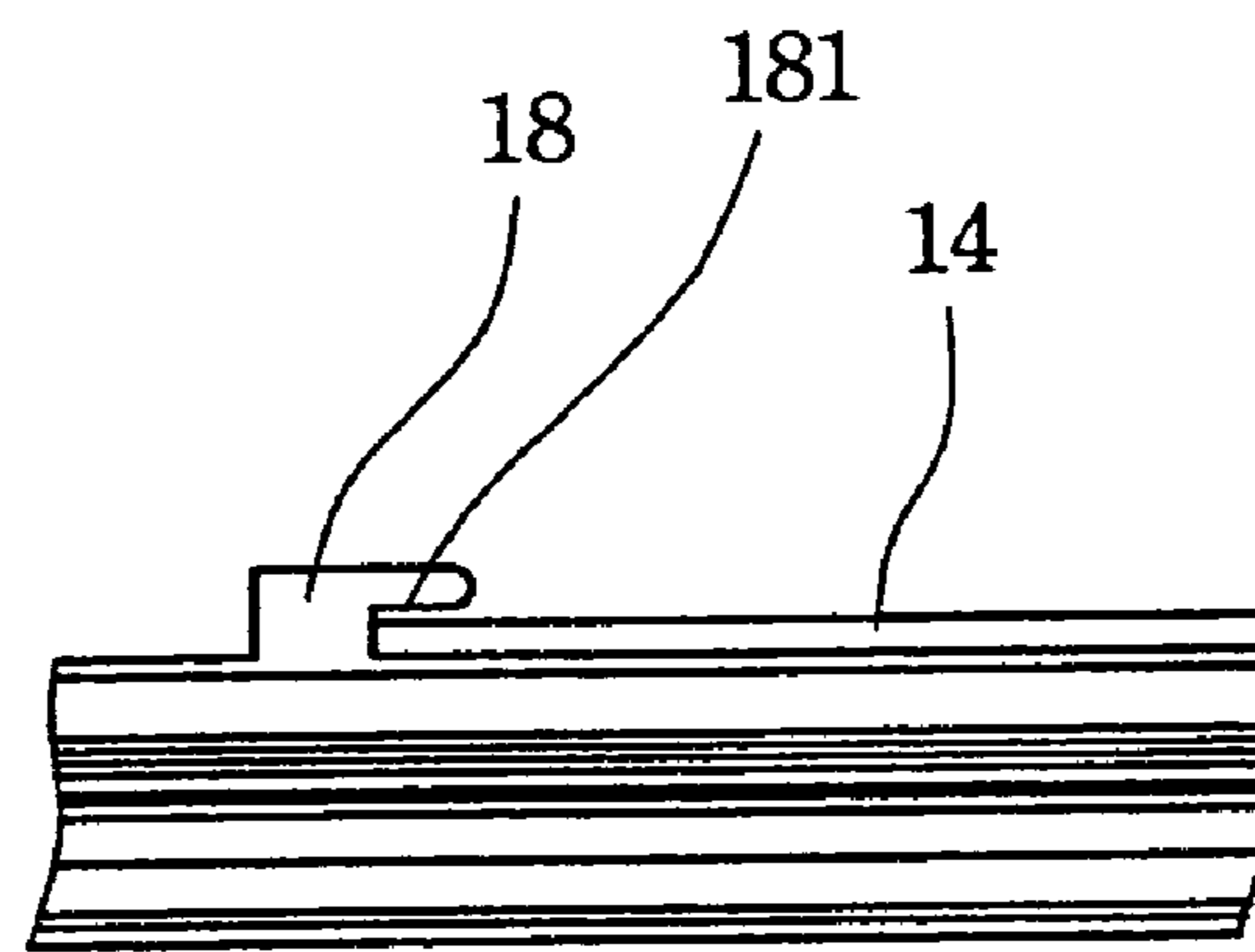

Fig. 6

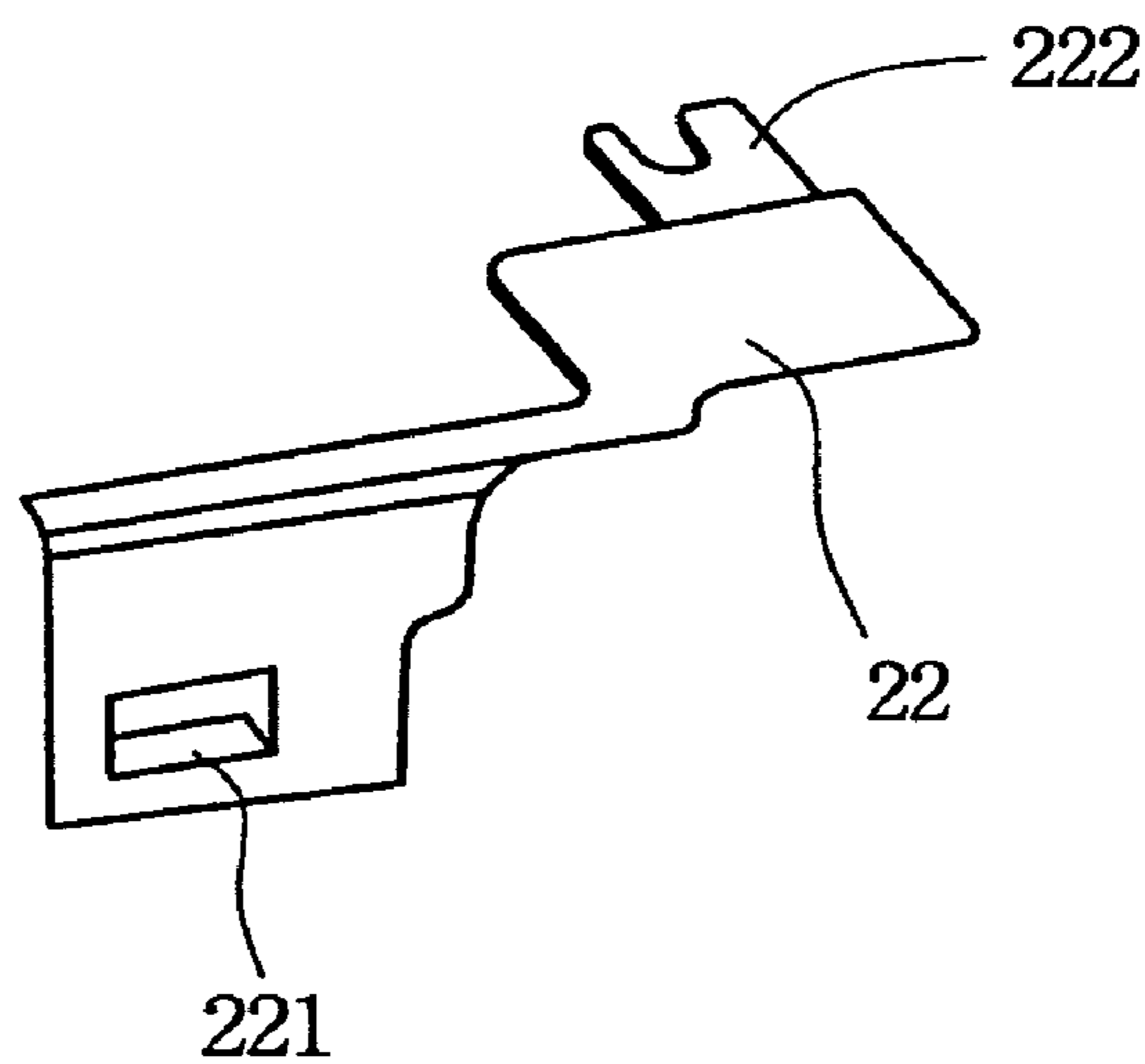

Fig. 7

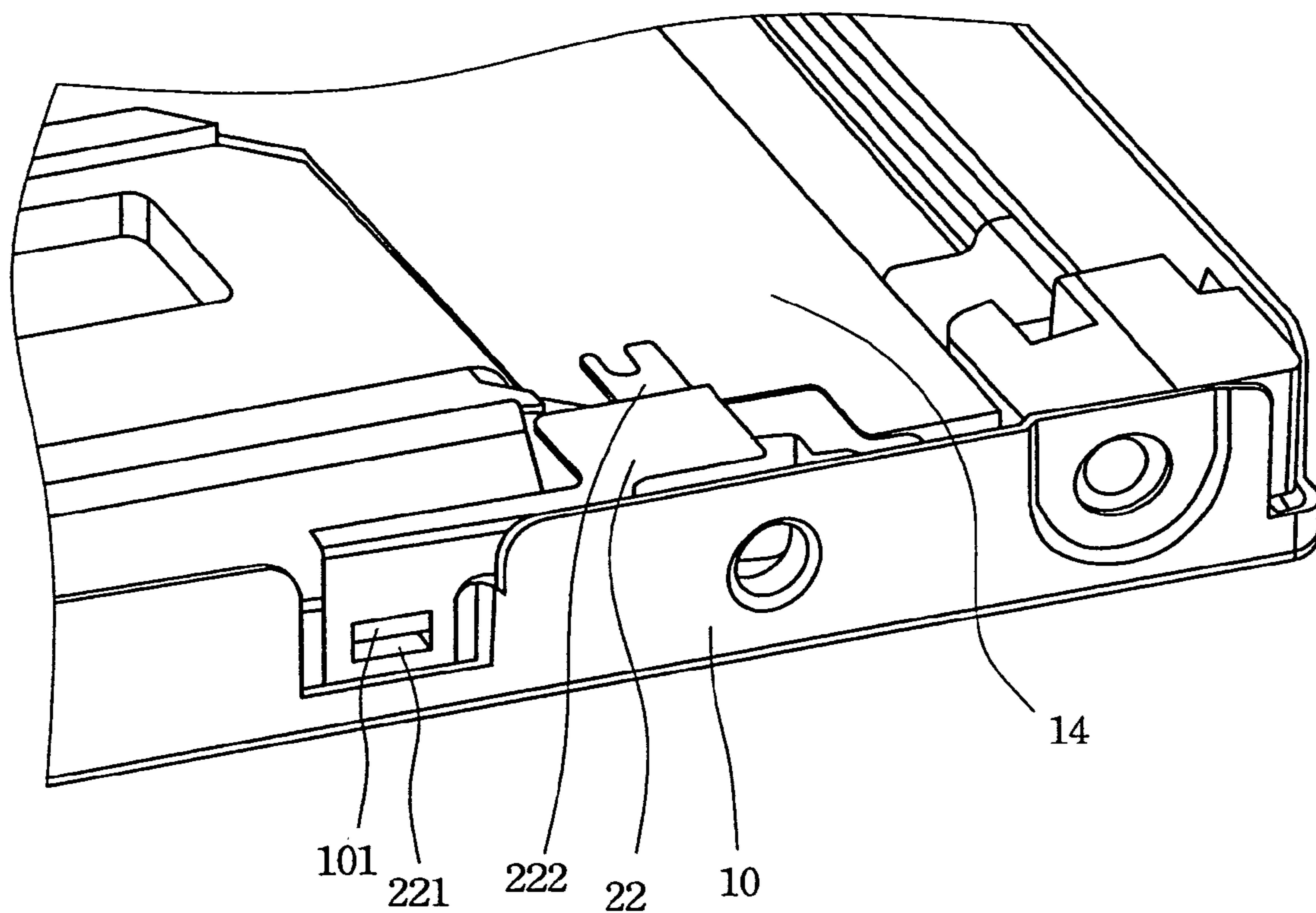

Fig. 8

LIQUID CRYSTAL MODULE COMPRISING FASTENERS FOR FLEXIBLE CIRCUIT BOARD

BACKGROUND OF THE INVENTION

1. Field of Invention

The present invention relates to a frame structure and a grounding structure. More particularly, the present invention relates to a frame structure and a grounding structure of a liquid crystal module (LCM).

2. Description of Related Art

Liquid crystal display (LCD) has so many advantages, including high picture quality, small volume, light weight, low driving voltage and low power consumption, that LCDs are widely applied in electronic products such as medium or small-sized portable televisions, mobile phones, videos, notebooks, monitors for desktop computers and projection-type televisions. Therefore, as time goes by, LCDs gradually replace present cathode ray tube (CRT) monitors.

The primary processes to manufacture a LCD includes a thin film transistor array substrate process, a color filter layer process, a liquid crystal cell assembling process, and a liquid crystal module (LCM) assembling process.

The LCM assembling process is to assemble a metal bezel, a liquid crystal display panel and a back light module together. After finishing the LCM assembling process, the processes to manufacture a LCD is completed. More specifically, the LCM assembling process is to overlap the liquid crystal display panel, on which a flexible printed circuit board (FPC) is fastened, with the back light module first. Then, the metal bezel locks with the fame, wherein the FPC is bent to be secured at back of the fame and is electrically connected to a control printed circuit board.

However, a lot of problems exist in the conventional LCM assembling process. For example, reference is made to FIG. 1, which illustrates how to fixedly secure a flexible printed circuit board (FPC) 12 on a frame 11 according to prior arts. When the driving ICs are attached on the liquid crystal display panel (not shown) by chip-on-glass (COG) technique, the area of the FPC 12, which is connected to the driving ICs, is large. According to the conventional method, the FPC 12 is fastened on the frame 111 via the tape 13 because of large area of the FPC 12. However, this kind of assembly procedure takes a lot of time. Besides, owing to adoption of COG technique, the FPC 12 is bent twice, and the produced torsion easily makes the FPC 12 separate outward from the frame 11. The FPC 12 is not thoroughly secured on the frame 11.

Moreover, as far as the control printed circuit board (control PCB) 14, which is electrically connected to the connector 15 and the FPC 12, is fastened on the frame 11 via the screws. However, this kind of assembly procedure takes a lot of time and consumes cost of screws.

Reference is made to FIG. 2, which is a partial perspective view illustrating a structure of a conventional LCM. The control PCB 14 is electrically connected to the grounding copper foil 16 by welding at one end, and keeps electrically contact with the metal bezel 10 at the other end. The grounding copper foil 16 is fastened on the metal bezel 10 via the screw through the hole 17. However, this kind of assembly procedure takes a lot of time and consumes cost of screws. In case that the metal bezel 10 is not thick enough, the space is limited to form a hole 17 for securing the grounding copper foil 16 on the metal bezel 10 via the screw.

SUMMARY OF THE INVENTION

For the forgoing reasons, it is therefore an objective of the present invention to provide a frame structure adapted for fixedly securing a FPC which is electrically connected to a liquid crystal display panel, and for fixedly securing a control PCB which is electrically connected to the FPC.

Another objective of the present invention is to provide a grounding structure for protecting a control PCB of a LCD from electromagnetic interference.

In one aspect, a frame structure of a liquid crystal module, the frame being adapted for fixedly securing a flexible printed circuit board which is electrically connected to a liquid crystal display panel, and for fixedly securing a control printed circuit board which is electrically connected to the flexible printed circuit board, is provided. The frame includes a plurality of fasteners and a recess for receiving the control printed circuit board. Each fastener including a first clip piece and a second clip piece. A periphery of the recess includes a slot, a plurality of protrusions and a plurality of resilient engaging pieces. By clipping the flexible printed circuit board between the first clip piece and the second clip piece, the flexible printed circuit board is fixedly secured on the frame. By engaging the control printed circuit board on the recess with the slot, the protrusions and the resilient engaging pieces, the control printed circuit board is fixedly secured on the frame.

In another aspect, a grounding structure of a liquid crystal module, the grounding structure being adapted for protecting a control printed circuit board of the liquid crystal module from electromagnetic interference, is provided. The grounding structure includes frame for receiving the control printed circuit board, a grounding conductive sheet, and a metal bezel for locking around the frame. One end of the grounding conductive sheet is electrically connected to the control printed circuit board, and the other end comprises a first engaging member. The metal bezel includes a second engaging member, wherein the second engaging member engages with the first engaging member.

It is to be understood that both the foregoing general description and the following detailed description are examples only, and are intended to provide further explanation of the invention as claimed.

BRIEF DESCRIPTION OF THE DRAWINGS

The accompanying drawings are included to provide a further understanding of the invention, and are incorporated in and constitute a part of this specification. The drawings illustrate embodiments of the invention and, together with the description, serve to explain the principles of the invention. In the drawings,

FIG. 1 illustrates how to fixedly secure a flexible printed circuit board on a frame according to prior arts;

FIG. 2 is a partial perspective view illustrating a structure of a conventional LCM;

FIG. 3 is a partial perspective view illustrating a structure of a frame in accordance with the present invention;

FIG. 4 illustrates how to fixedly secure a flexible printed circuit board on a frame according to the present invention;

FIG. 5 illustrates how to fixedly secure a control printed circuit board on a frame according to the present invention;

FIG. 6 is a perspective, cross-sectional view of FIG. 5 taken along 6—6;

FIG. 7 is a perspective view illustrating a structure of a grounding copper foil in accordance with the present invention; and

3

FIG. 8 is a partial perspective view illustrating a structure of a grounding structure in accordance with the present invention.

DESCRIPTION OF THE PREFERRED EMBODIMENTS

Reference will now be made in detail to the present preferred embodiments of the invention, examples of which are illustrated in the accompanying drawings. Wherever possible, the same reference numbers are used in the drawings and the description to refer to the same or like parts.

Reference is made to FIG. 3, which is a partial perspective view illustrating a structure of a frame in accordance with the present invention. The frame 18 can be formed by integral injection molding, and is preferably made of plastic. A plurality of fasteners 21 are formed on the frame 18. Each fastener 21 includes a first clip piece 212 and a second clip piece 211. Covered area of the first clip piece 212 is larger than covered area of the second clip piece 211. A gap 23 is disposed between the first clip piece 212 and the second clip piece 211. As shown in FIG. 4, to assemble the FPC 12 with the frame 18, the FPC 12 is inserted into a position between the first clip piece 212 and the second clip piece 211.

Reference is made to FIGS. 5 and 6. FIG. 5 illustrates how to fixedly secure a control printed circuit board on a frame according to the present invention. FIG. 6 is a perspective, cross-sectional view of FIG. 5 taken along 6—6. A recess 20 is formed on the frame 18 for receiving the control PCB 14. A periphery of the recess 20 includes a slot 181, a plurality of protrusions 182 and a plurality of resilient engaging pieces 183. A gap 21 is disposed between the resilient engaging piece 183 and a body of the frame 18. To assemble the control PCB 14 with the frame 18, the control PCB 14 is inserted into the slot 181, and positioned by the protrusions 182. After the resilient engaging pieces 183 are pulled backward and is released, the control PCB 14 can be fastened into the recess 20. By engaging the control PCB 14 on the recess with the slot 181, the protrusions 182 and the resilient engaging pieces 183, the control PCB 14 is fixedly secured on the frame 18.

Reference is made to FIGS. 7 and 8. FIG. 7 is a perspective view illustrating a structure of a grounding copper foil in accordance with the present invention. FIG. 8 is a partial perspective view illustrating a structure of a grounding structure in accordance with the present invention. To assemble the grounding copper foil 22 with the LCM, a soldering portion 222 of the grounding copper foil 22 is welded onto the control PCB 14, and a resilient piece 221 of the grounding copper foil 22 engages with a hook 101 of the metal bezel 10. Certainly, other kinds of designs to assemble the grounding copper foil 22 with the metal bezel 10 are also feasible. For example, an opening is formed on the grounding copper foil 22, and a hook is formed on the metal bezel 10, wherein the opening can engage with the hook.

It will be apparent to those skilled in the art that various modifications and variations can be made to the structure of the present invention without departing from the scope or spirit of the invention. In view of the foregoing, it is intended

4

that the present invention cover modifications and variations of this invention provided they fall within the scope of the following claims and their equivalents.

What is claimed is:

1. A frame structure of a liquid crystal module, said frame structure being adapted for fixedly securing a flexible printed circuit board which is electrically connected to a liquid crystal display panel, said frame structure comprising:
 - a plurality of fasteners, each fastener including:
 - a first clip piece with a hole; and
 - a second clip piece connected to said first clip and substantially located within said hole, wherein a gap is formed between said first clip piece and said second clip piece, and an edge of said flexible printed circuit board is secured by being disposed into said gap.
2. The frame structure according to claim 1, wherein said frame structure is made of plastic.
3. The frame structure according to claim 1, wherein said frame structure is formed by integral injection molding.
4. The frame structure according to claim 1, wherein the first and second clip pieces are a part of a frame, and wherein the flexible printed circuit board is secured to the frame by the fasteners.
5. The frame structure according to claim 1, wherein both of the first and second clip pieces extend from a frame, and wherein the flexible printed circuit board is secured to the frame by the fasteners.
6. A frame structure of a liquid crystal module, said frame structure being adapted for fixedly securing a flexible printed circuit board which is electrically connected to a liquid crystal display panel, and for fixedly securing a control printed circuit board which is electrically connected to said flexible printed circuit board, said structure comprising:
 - a plurality of fasteners, each fastener including:
 - a first clip piece with a hole;
 - a second clip connected to said first clip and substantially located within said hole, wherein a gap is formed between said first clip piece and said second clip piece, and an edge of said flexible printed circuit board is secured by being disposed into said gap; and
 - a recess having a first edge, a second edge, a third edge and a fourth edge, said recess comprising:
 - a slot on said first edge of said recess, for receiving said control printed circuit board;
 - a plurality of protrusions on said second edge, said third edge and said fourth edge of said recess, for fixing said control printed circuit board in said recess; and
 - a plurality of resilient engaging pieces disposed at said third edge, which is opposite to said first edge, of said recess for engaging with said control printed circuit board.
7. The frame structure according to claim 6, wherein said frame structure is made of plastic.
8. The frame structure according to claim 6, wherein said frame structure is formed by integral injection molding.

* * * * *

UNITED STATES PATENT AND TRADEMARK OFFICE
CERTIFICATE OF CORRECTION

PATENT NO. : 7,038,741 B2
APPLICATION NO. : 10/671386
DATED : May 2, 2006
INVENTOR(S) : Lai et al.

Page 1 of 1

It is certified that error appears in the above-identified patent and that said Letters Patent is hereby corrected as shown below:

Title Page 1, Column 1, under Assignee, Line 2, After “(TW)” insert --R.O.C.--.

Title Page 1, Column 2, under U.S. Patent Documents, Line 4, After “6,686,979” delete “B1” and insert --B2--, therefor.

In Column 1, Line 44, Delete “111” and insert --11--, therefor.

In Column 2, Line 10, Delete “electromagnetic” and insert --electro-magnetic--, therefor.

In Column 2, Line 31, Delete “electromagnetic” and insert --electro-magnetic--, therefor.

Signed and Sealed this

Twenty-sixth Day of December, 2006

A handwritten signature in black ink on a light gray dotted background. The signature reads "Jon W. Dudas" in a cursive style.

JON W. DUDAS

Director of the United States Patent and Trademark Office