



US007035059B2

(12) **United States Patent**
Gill

(10) **Patent No.:** **US 7,035,059 B2**
(45) **Date of Patent:** **Apr. 25, 2006**

(54) **HEAD WITH SELF-PINNED STRUCTURE HAVING PINNED LAYER EXTENDING BEYOND TRACK EDGES OF THE FREE LAYER**

6,411,478 B1	6/2002	Mao et al.	360/324.2
6,501,626 B1	12/2002	Gill	360/324.11
6,515,573 B1	2/2003	Dong et al.	338/32
6,888,706 B1 *	5/2005	Ooshima	360/324.12
2001/0028541 A1	10/2001	Gill	360/324.12
2001/0050834 A1	12/2001	Hasegawa et al.	360/324.12
2001/0053052 A1	12/2001	Ihara et al.	360/324.1
2002/0085323 A1	7/2002	Smith et al.	360/324.12

(75) Inventor: **Hardayal Singh Gill**, Palo Alto, CA (US)

(73) Assignee: **Hitachi Global Storage Technologies, Netherland B.V.**, Amsterdam (NL)

(Continued)

FOREIGN PATENT DOCUMENTS

(*) Notice: Subject to any disclaimer, the term of this patent is extended or adjusted under 35 U.S.C. 154(b) by 241 days.

JP 2000-163717 6/2000

(Continued)

OTHER PUBLICATIONS

(21) Appl. No.: **10/622,936**

Cho, Hae Seok, "Effect of Pinning Field on the Magnetization in Patterned Synthetic Antiferromagnetic Spin Valves," Journal of Applied Physics, May 1, 2000, vol. 87, No. 9.

(22) Filed: **Jul. 18, 2003**

(65) **Prior Publication Data**

US 2005/0013061 A1 Jan. 20, 2005

Primary Examiner—A. J. Heinz

(74) Attorney, Agent, or Firm—Zilka-Kotab, PC

(51) **Int. Cl.**
G11B 5/39 (2006.01)

(57) **ABSTRACT**

(52) **U.S. Cl.** **360/324.11**

(58) **Field of Classification Search**
360/324.11–324.12

See application file for complete search history.

A magnetic head having an antiparallel (AP) pinned layer structure having at least two pinned layers with magnetic moments that are self-pinned antiparallel to each other. The pinned layers are separated by an AP coupling layer. A bias layer with a pinned magnetic moment is spaced apart from the AP pinned layer structure. A free layer is positioned between the AP pinned layer structure and the bias layer. At least one of the pinned layers extends beyond track edges of the free layer in a direction parallel to the ABS. Optional antiferromagnetic (AFM) layers can be positioned outside the track edges of the free layer in a direction parallel to the ABS (but not necessarily aligned with the free layer). The AFM layers pin a magnetic orientation of portions of the pinned layer closest thereto that are positioned outside the track edges of the free layer.

(56) **References Cited**

U.S. PATENT DOCUMENTS

5,657,191 A	8/1997	Yuan	360/113
5,661,621 A	8/1997	Kobayashi et al.	360/113
6,046,891 A	4/2000	Yoda et al.	360/113
6,064,552 A	5/2000	Iwasaki et al.	360/113
6,074,767 A	6/2000	Lin	428/692
6,150,045 A	11/2000	Saito et al.	428/692
6,268,985 B1 *	7/2001	Pinarbasi	360/324.12
6,292,335 B1	9/2001	Gill	360/324.11
6,327,121 B1	12/2001	Nagasawa et al.	360/324.11
6,396,668 B1	5/2002	Mao et al.	360/314

20 Claims, 11 Drawing Sheets

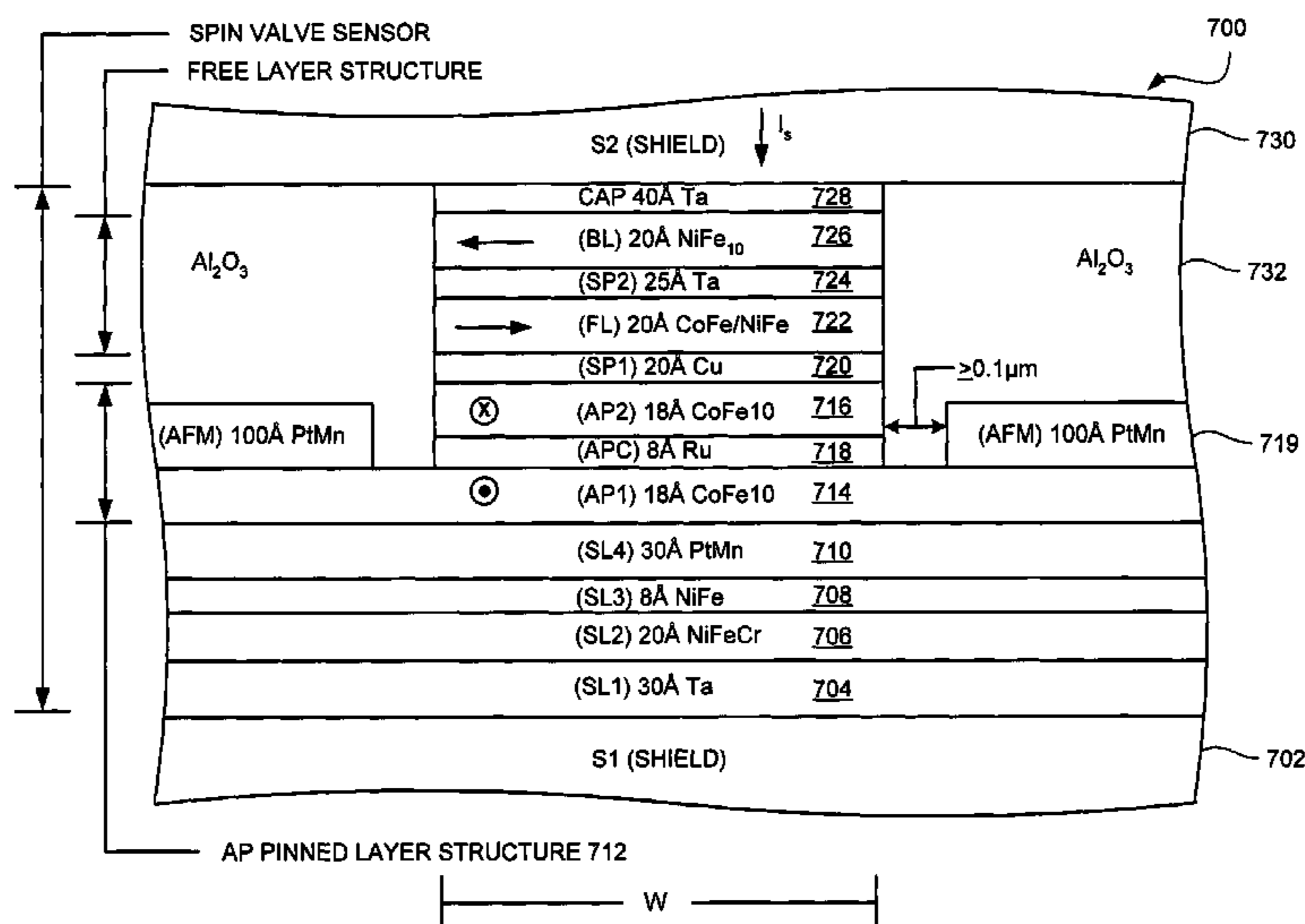

US 7,035,059 B2

Page 2

U.S. PATENT DOCUMENTS

2002/0097538	A1	7/2002	Seyama et al.	360/324.11
2002/0114111	A1	8/2002	Zhu	360/324.11
2002/0114113	A1	8/2002	Lederman et al.	360/324.11
2002/0154456	A1	10/2002	Carey et al.	360/324.11

FOREIGN PATENT DOCUMENTS

JP	2001-160640	6/2001
JP	2002-270920	9/2002
* cited by examiner		

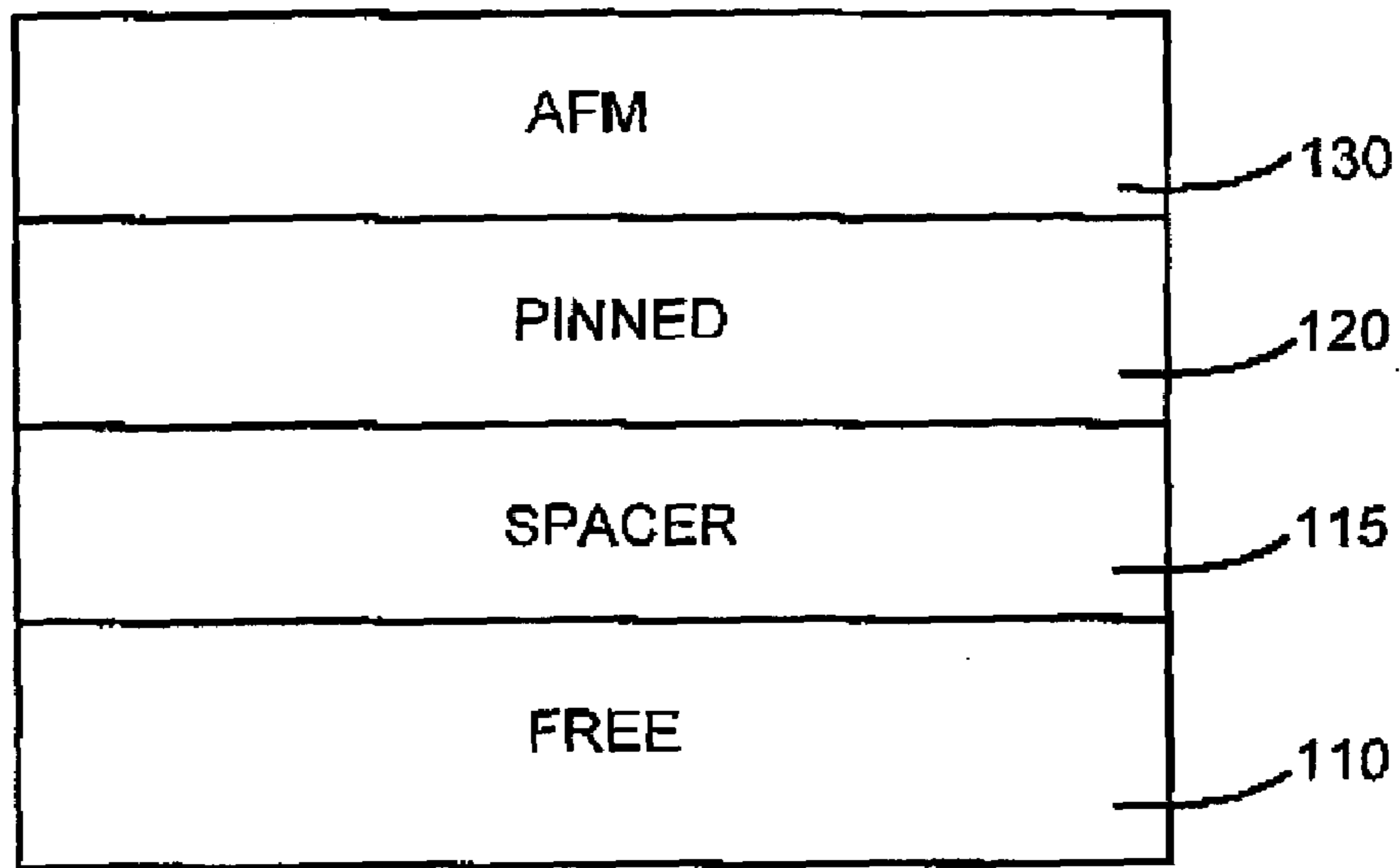

FIG. 1A
(prior art)

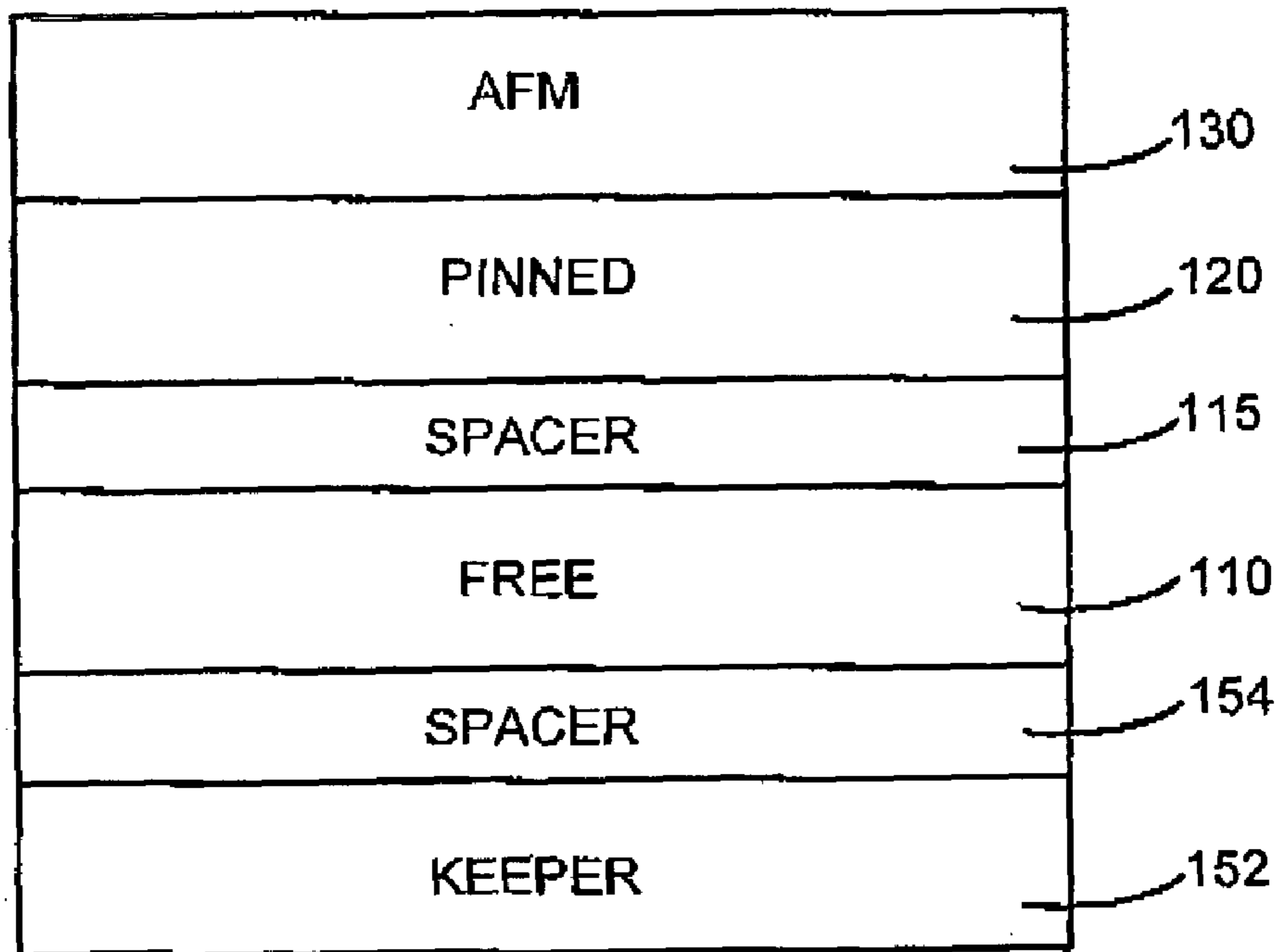
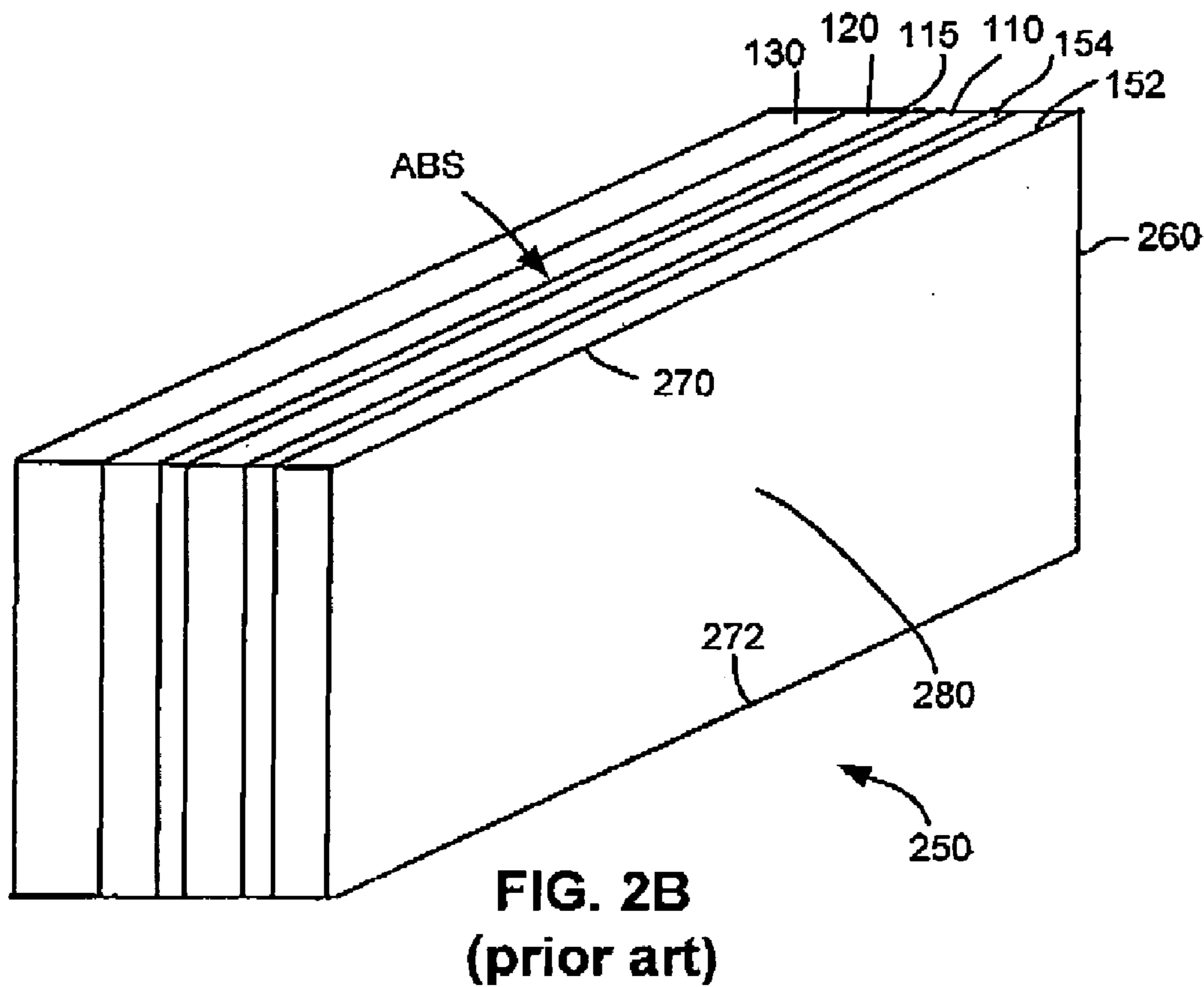
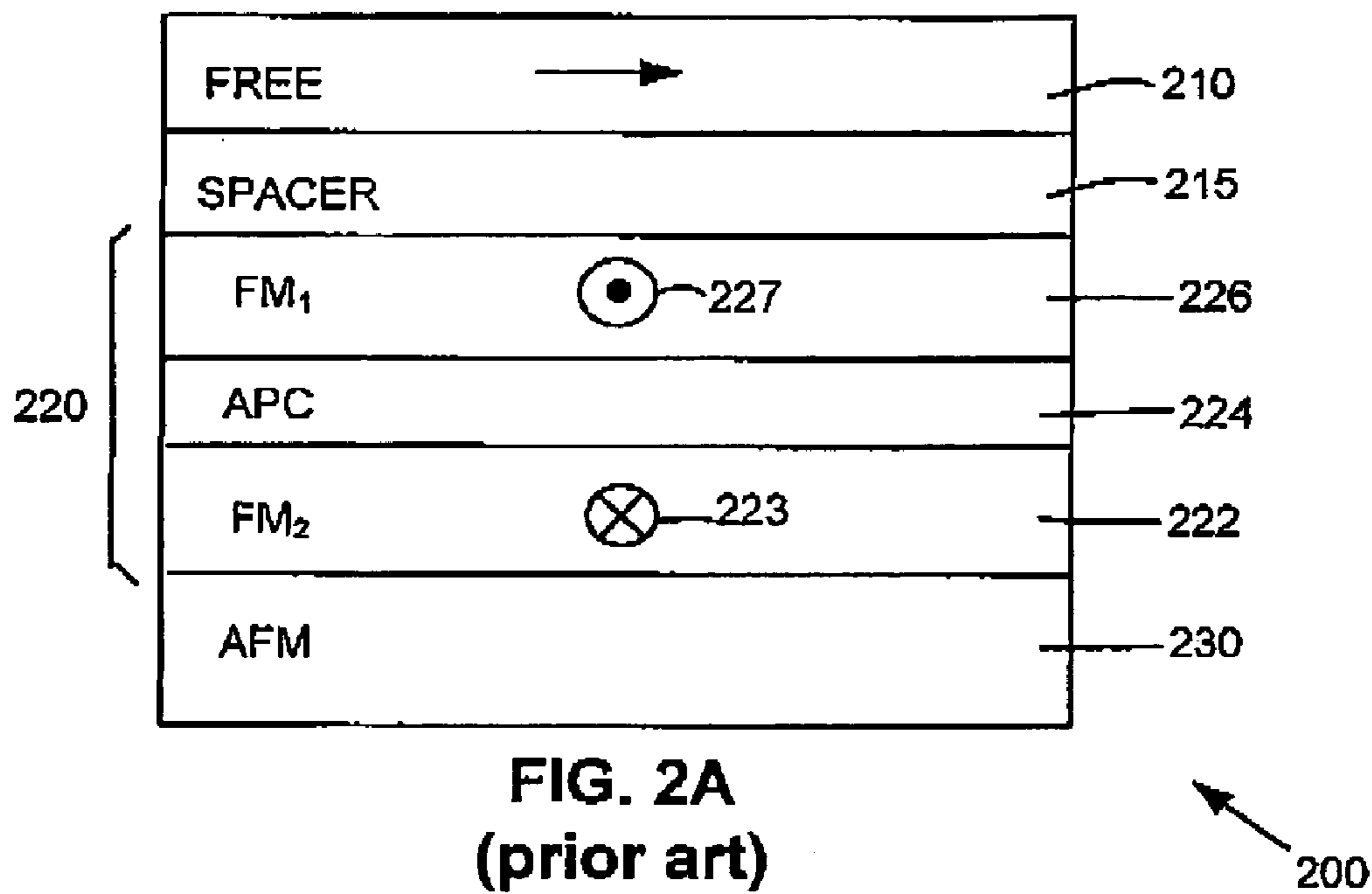

FIG. 1B
(prior art)



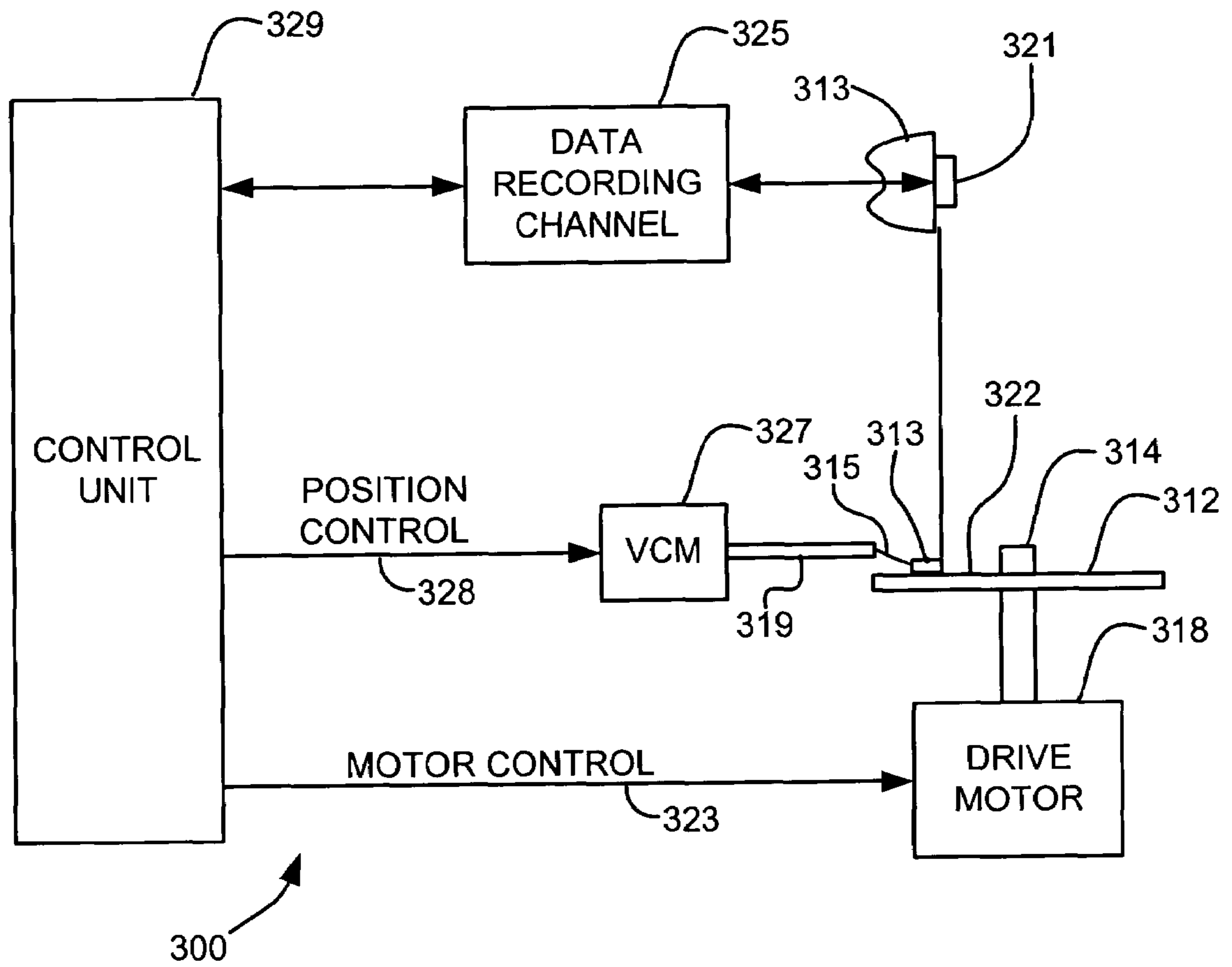

FIG. 3

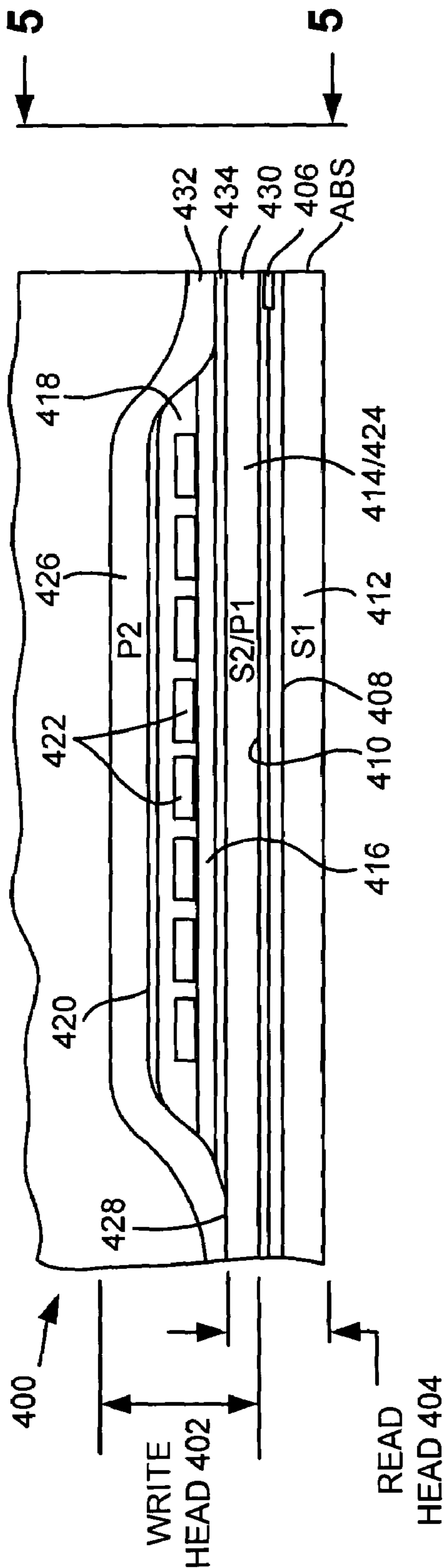

FIG. 4

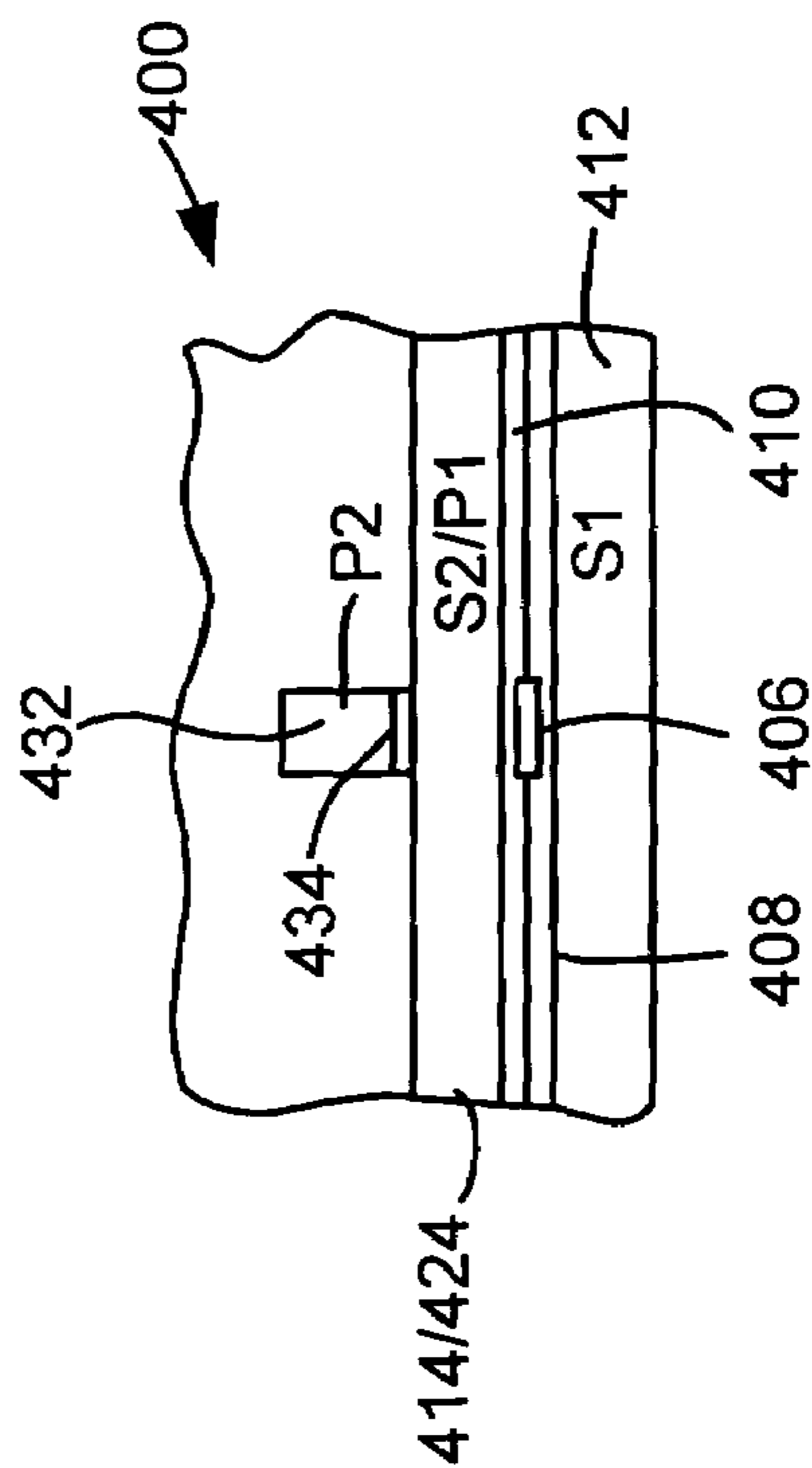

FIG. 5

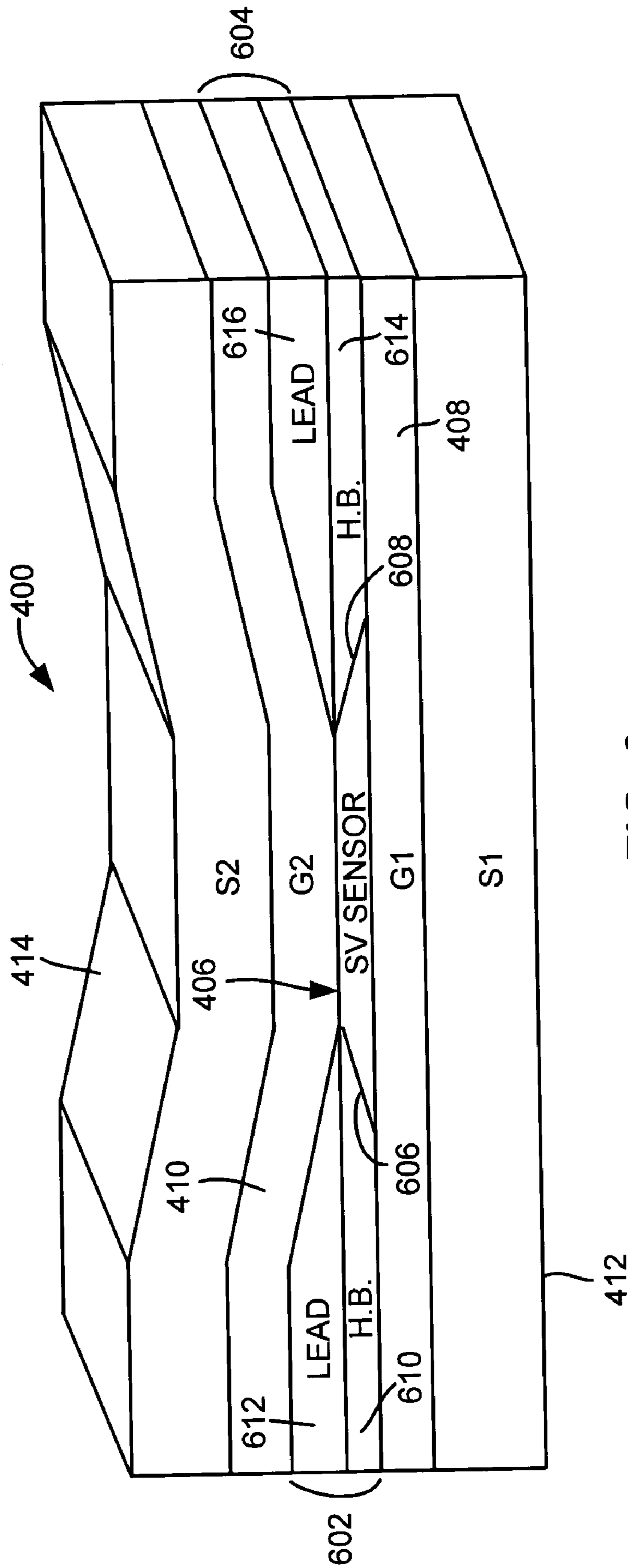

FIG. 6

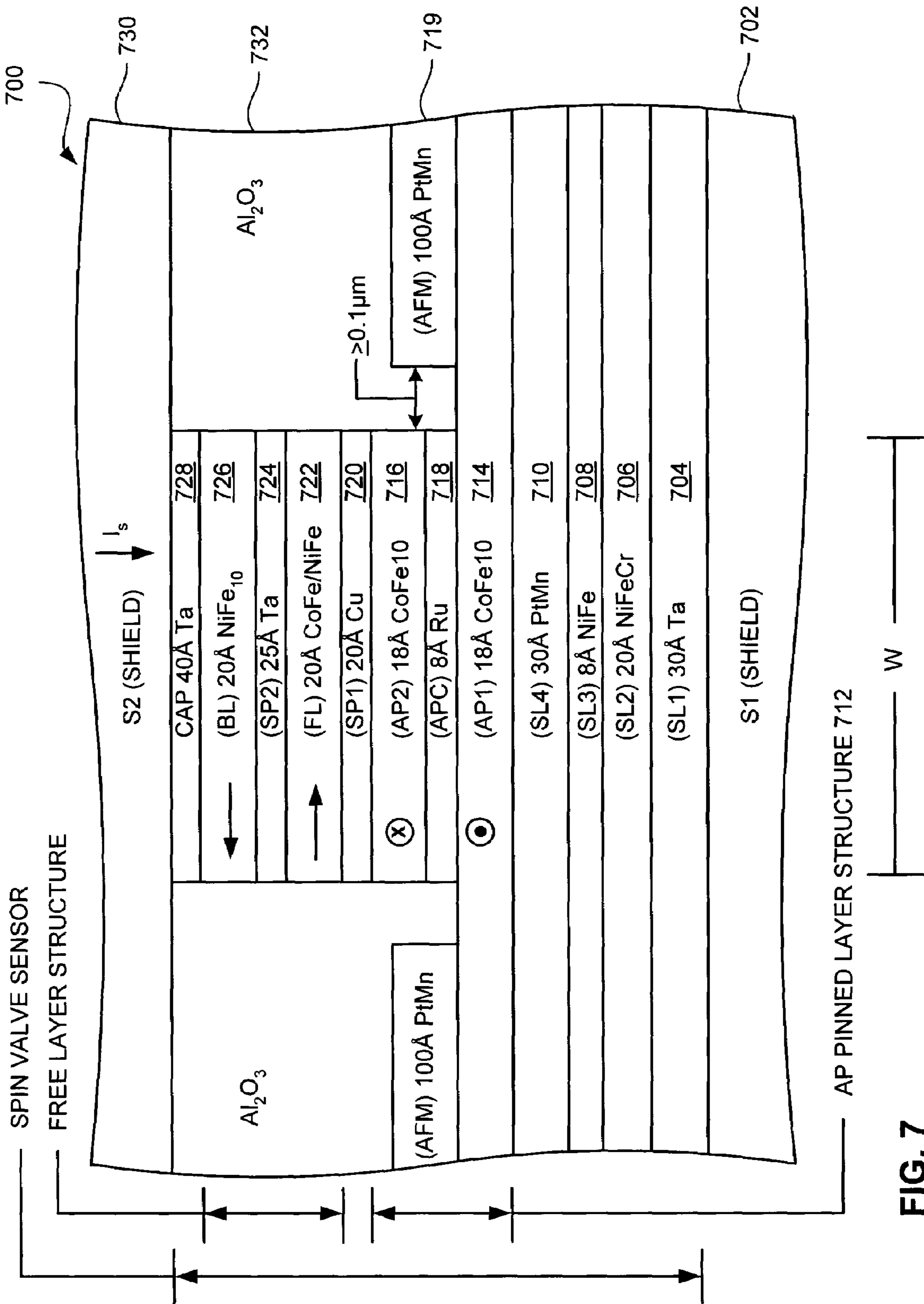

FIG. 7

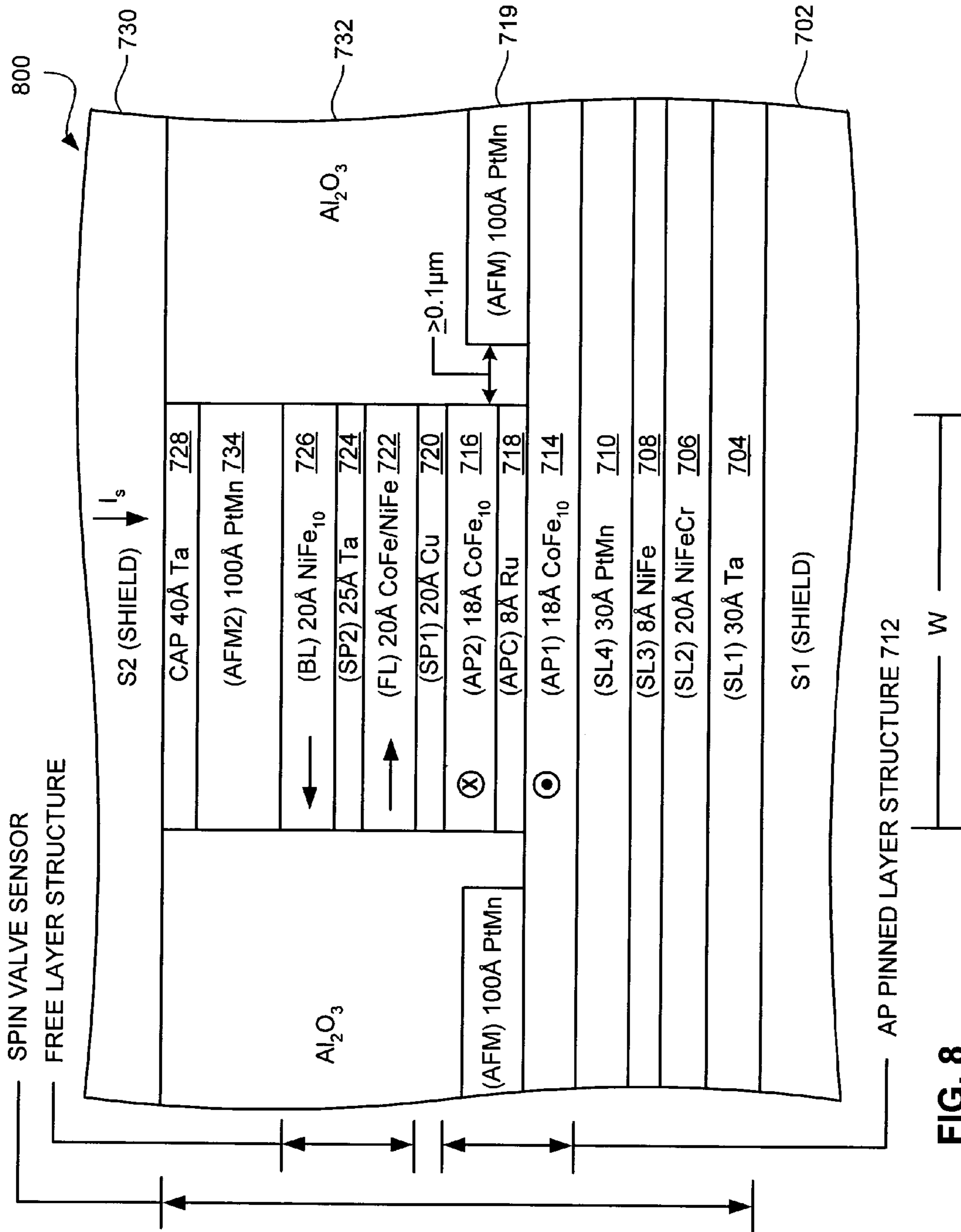

FIG. 8

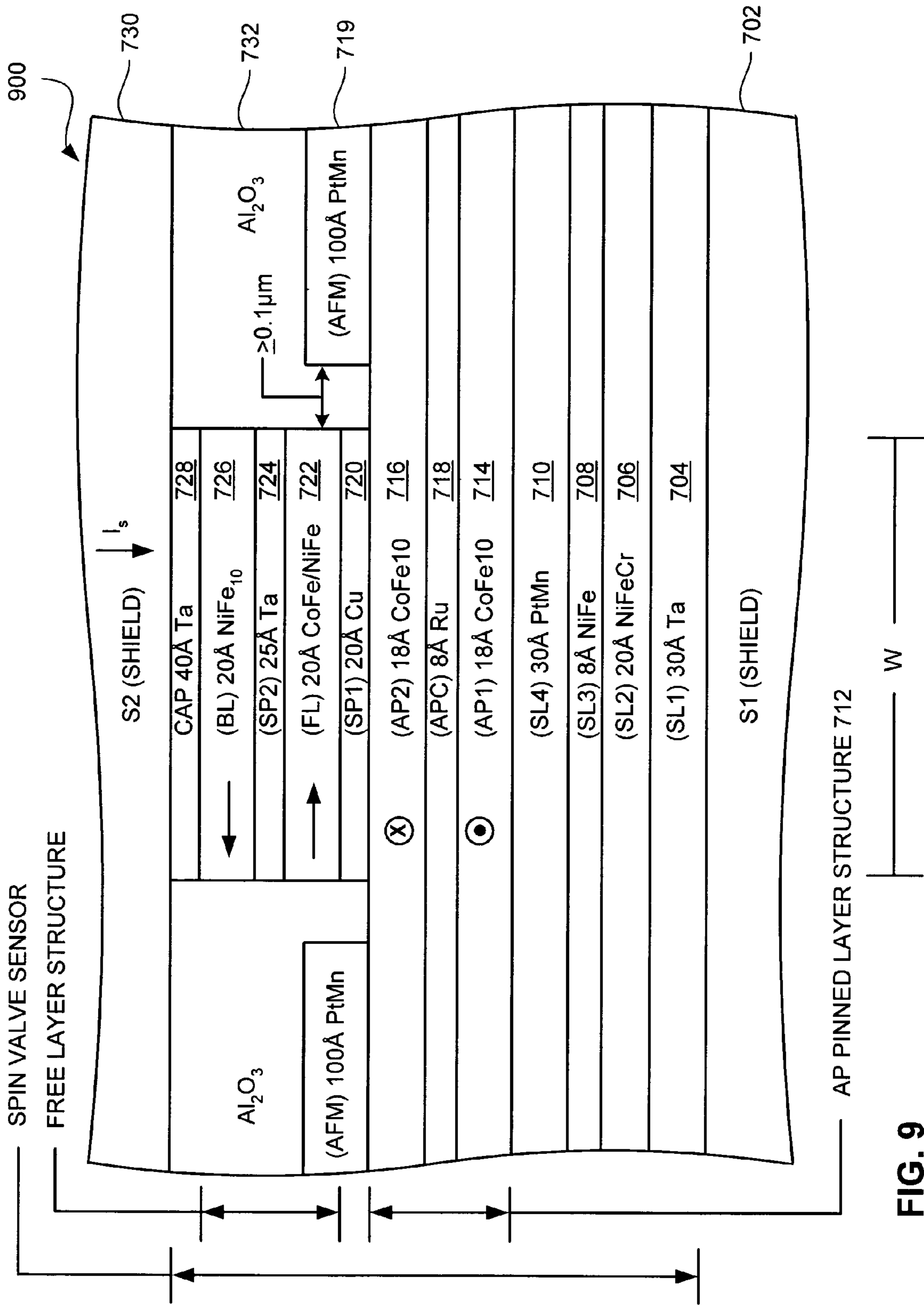

FIG. 9

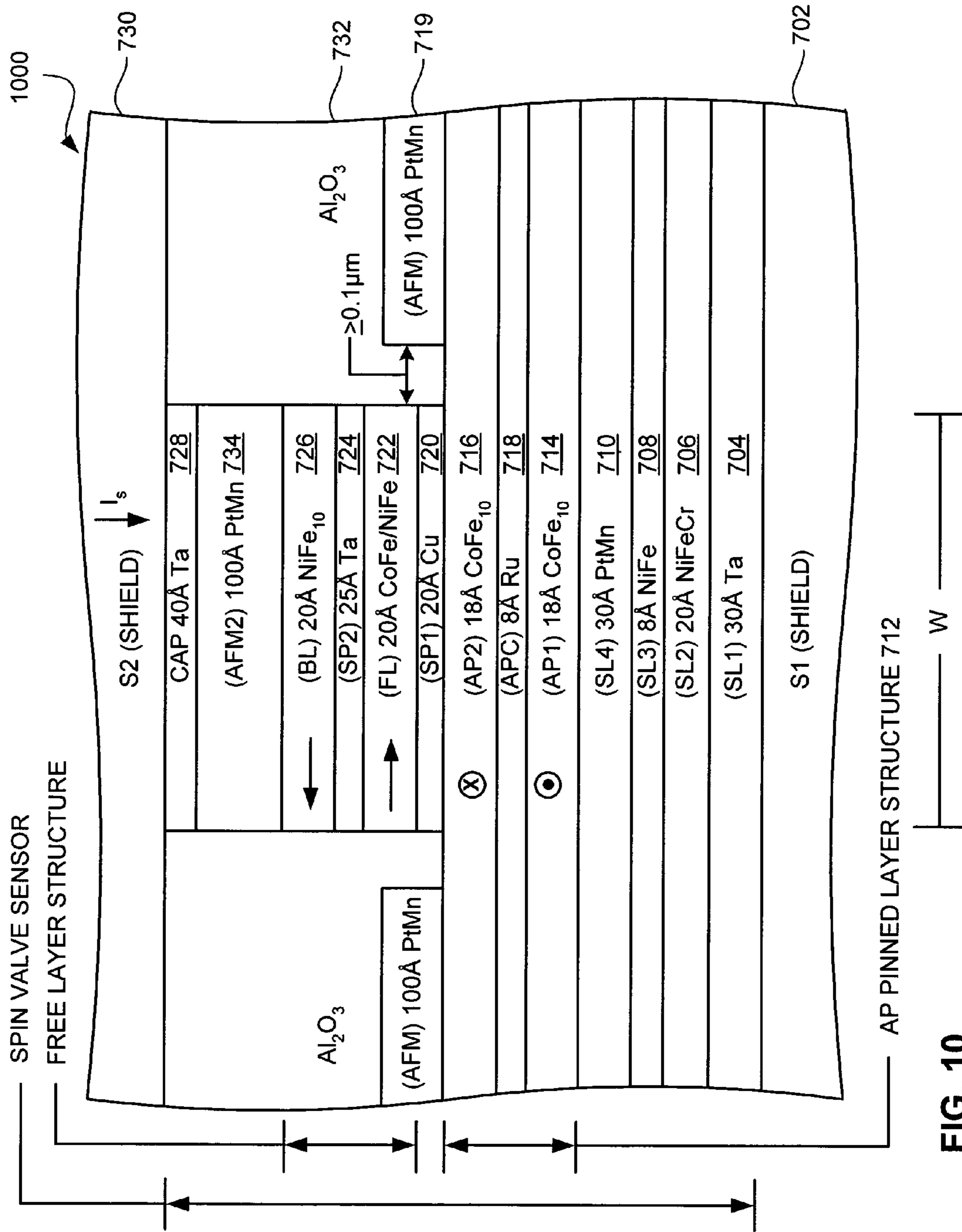

FIG. 10

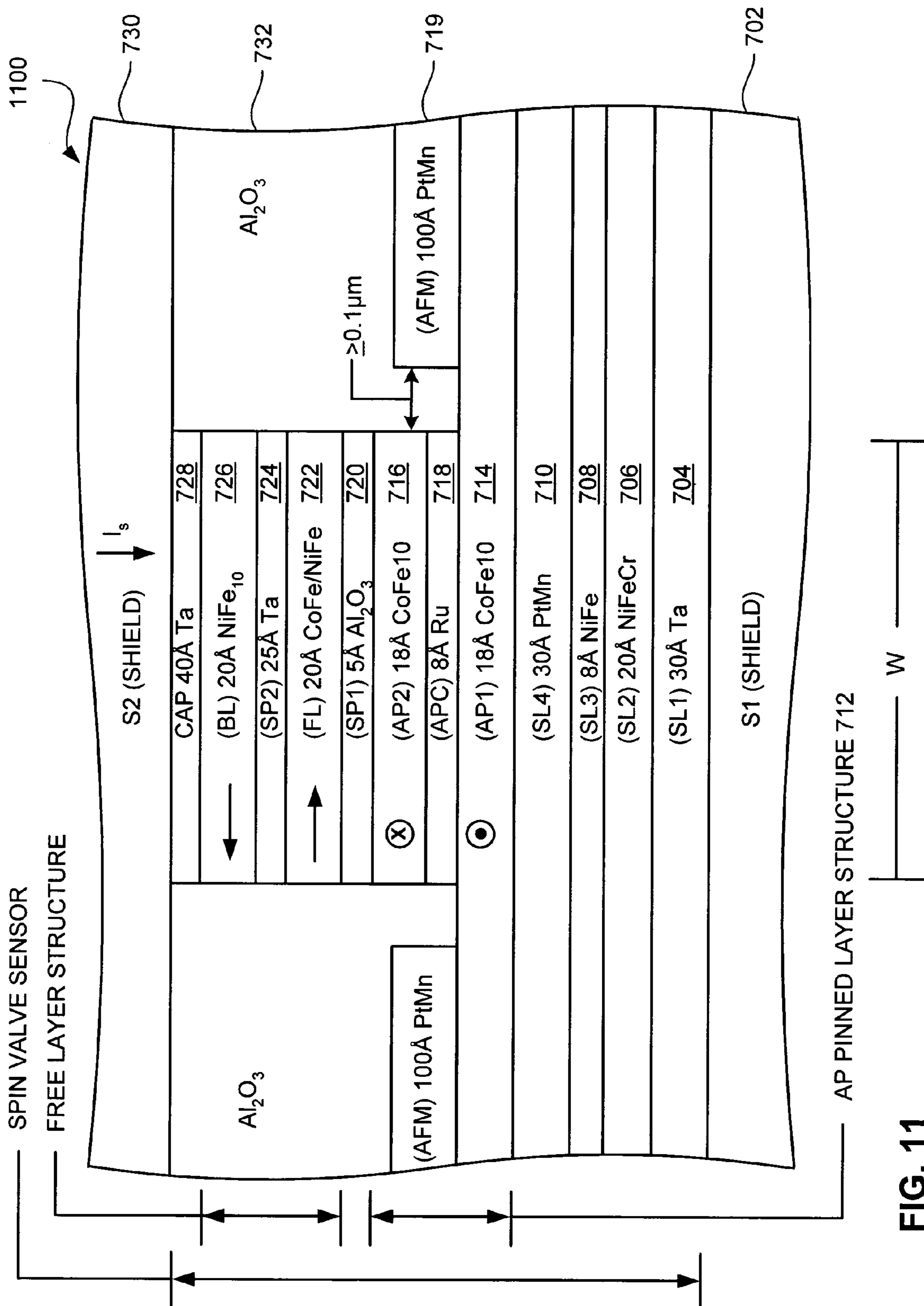

FIG. 11

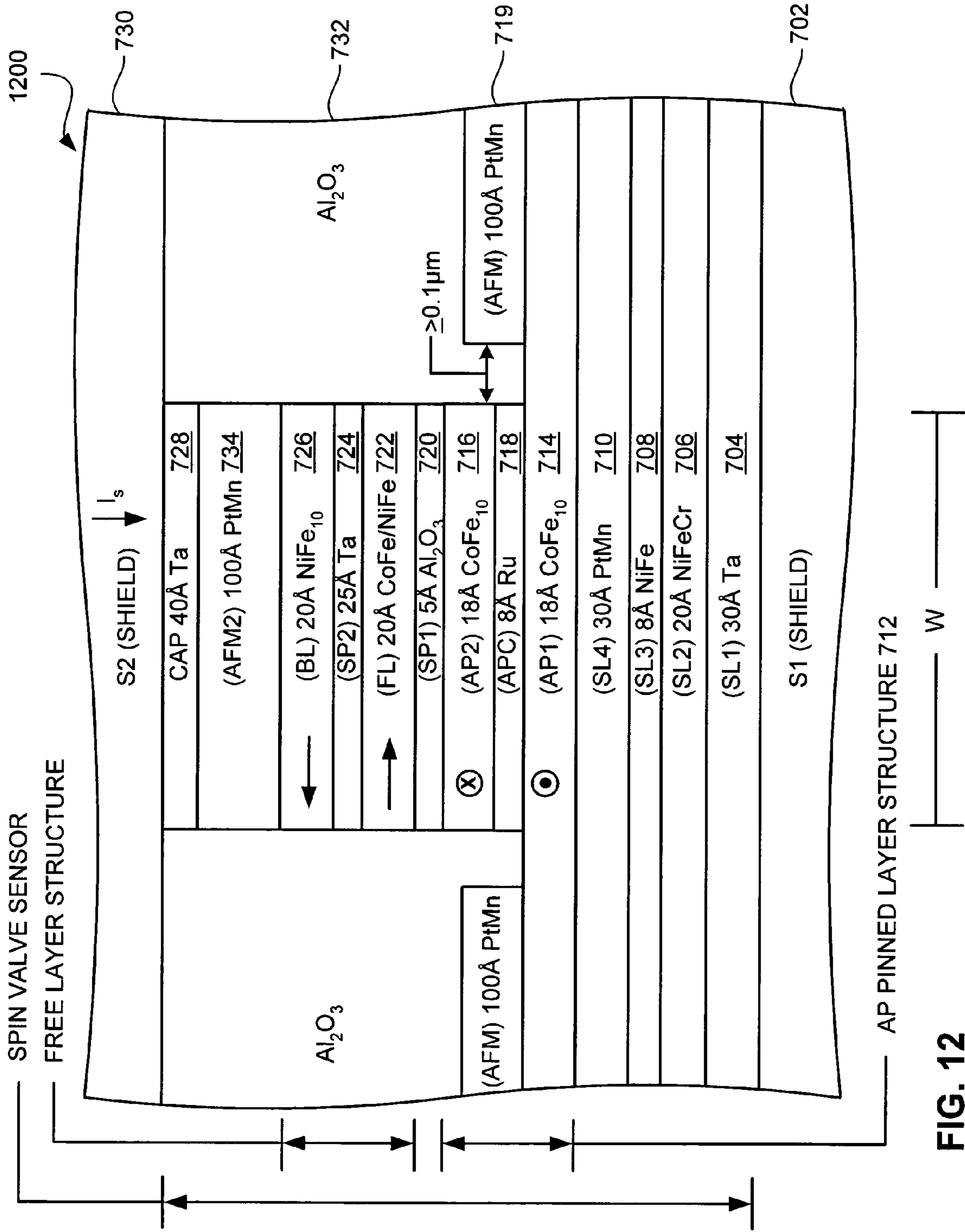

FIG. 12

**HEAD WITH SELF-PINNED STRUCTURE
HAVING PINNED LAYER EXTENDING
BEYOND TRACK EDGES OF THE FREE
LAYER**

FIELD OF THE INVENTION

The present invention relates to magnetic heads, and more particularly, this invention relates to read heads having magnetically pinned layers with enhanced pinning.

BACKGROUND OF THE INVENTION

The heart of a computer is a magnetic disk drive which includes a rotating magnetic disk, a slider that has read and write heads, a suspension arm above the rotating disk and an actuator arm that swings the suspension arm to place the read and write heads over selected circular tracks on the rotating disk. The suspension arm biases the slider into contact with the surface of the disk when the disk is not rotating but, when the disk rotates, air is swirled by the rotating disk adjacent an air bearing surface (ABS) of the slider causing the slider to ride on an air bearing a slight distance from the surface of the rotating disk. When the slider rides on the air bearing the write and read heads are employed for writing magnetic impressions to and reading magnetic signal fields from the rotating disk. The read and write heads are connected to processing circuitry that operates according to a computer program to implement the writing and reading functions.

In high capacity disk drives, magnetoresistive (MR) read sensors, commonly referred to as MR heads, are the prevailing read sensors because of their capability to read data from a surface of a disk at greater track and linear densities than thin film inductive heads. An MR sensor detects a magnetic field through the change in the resistance of its MR sensing layer (also referred to as an "MR element") as a function of the strength and direction of the magnetic flux being sensed by the MR layer.

The conventional MR sensor operates on the basis of the anisotropic magnetoresistive (AMR) effect in which an MR element resistance varies as the square of the cosine of the angle between the magnetization in the MR element and the direction of sense current flow through the MR element. Recorded data can be read from a magnetic medium because the external magnetic field from the recorded magnetic medium (the signal field) causes a change in the direction of magnetization of the MR element, which in turn causes a change in resistance of the MR element and a corresponding change in the sensed current or voltage.

Another type of MR sensor is the giant magnetoresistance (GMR) sensor manifesting the GMR effect. In GMR sensors, the resistance of the GMR sensor varies as a function of the spin-dependent transmission of the conduction electrons between ferromagnetic layers separated by a non-magnetic layer (spacer) and the accompanying spin-dependent scattering which takes place at the interface of the ferromagnetic and non-magnetic layers and within the ferromagnetic layers.

GMR sensors using only two layers of ferromagnetic material (e.g., Ni—Fe) separated by a layer of non-magnetic material (e.g., copper) are generally referred to as spin valve (SV) sensors. In an SV sensor, one of the ferromagnetic layers, referred to as the pinned layer (reference layer), has its magnetization typically pinned by exchange coupling with an antiferromagnetic (e.g., NiO or Fe—Mn) layer. The pinning field generated by the antiferromagnetic layer

should be greater than demagnetizing fields (about 200 Oe) at the operating temperature of the SV sensor (about 120° C.) to ensure that the magnetization direction of the pinned layer remains fixed during the application of external fields (e.g., fields from bits recorded on the disk). The magnetization of the other ferromagnetic layer, referred to as the free layer, however, is not fixed and is free to rotate in response to the field from the recorded magnetic medium (the signal field). U.S. Pat. No. 5,206,590 granted to Diény et al., incorporated herein by reference, discloses a SV sensor operating on the basis of the GMR effect.

An exemplary high performance read head employs a spin valve sensor for sensing the magnetic signal fields from the rotating magnetic disk. FIG. 1A shows a prior art SV sensor **100** comprising a free layer (free ferromagnetic layer) **110** separated from a pinned layer (pinned ferromagnetic layer) **120** by a non-magnetic, electrically-conducting spacer layer **115**. The magnetization of the pinned layer **120** is fixed by an antiferromagnetic (AFM) layer **130**.

FIG. 1B shows another prior art SV sensor **150** with a flux keeper configuration. The SV sensor **150** is substantially identical to the SV sensor **100** shown in FIG. 1A except for the addition of a keeper layer **152** formed of ferromagnetic material separated from the free layer **110** by a non-magnetic spacer layer **154**. The keeper layer **152** provides a flux closure path for the magnetic field from the pinned layer **120** resulting in reduced magnetostatic interaction of the pinned layer **120** with the free layer **110**. U.S. Pat. No. 5,508,867 granted to Cain et al., incorporated herein by reference, discloses a SV sensor having a flux keeper configuration.

Another type of SV sensor is an antiparallel (AP)-pinned SV sensor. In AP-Pinned SV sensors, the pinned layer is a laminated structure of two ferromagnetic layers separated by a non-magnetic coupling layer such that the magnetizations of the two ferromagnetic layers are strongly coupled together antiferromagnetically in an antiparallel orientation. The AP-Pinned SV sensor provides improved exchange coupling of the antiferromagnetic (AFM) layer to the laminated pinned layer structure than is achieved with the pinned layer structure of the SV sensor of FIG. 1A. This improved exchange coupling increases the stability of the AP-Pinned SV sensor at high temperatures which allows the use of corrosion resistant antiferromagnetic materials such as NiO for the AFM layer.

Referring to FIG. 2A, an AP-Pinned SV sensor **200** comprises a free layer **210** separated from a laminated AP-pinned layer structure **220** by a nonmagnetic, electrically-conducting spacer layer **215**. The magnetization of the laminated AP-pinned layer structure **220** is fixed by an AFM layer **230**. The laminated AP-pinned layer structure **220** comprises a first ferromagnetic layer **226** and a second ferromagnetic layer **222** separated by an antiparallel coupling layer (APC) **224** of nonmagnetic material. The two ferromagnetic layers **226**, **222** (FM₁ and FM₂) in the laminated AP-pinned layer structure **220** have their magnetization directions oriented antiparallel, as indicated by the arrows **227**, **223** (arrows pointing out of and into the plane of the paper respectively).

A key requirement for optimal operation of an SV sensor is that the pinned layer should be magnetically saturated perpendicular to the air bearing surface. Lack of magnetic saturation in the pinned layer leads to reduced signal or dynamic range. Factors leading to a loss of saturation include demagnetizing fields at the edge of the pinned layer, magnetic fields from recorded data and from longitudinal biasing regions, current induced fields and the coupling field to the free layer.

Analysis of the magnetic state of pinned layers in small sensors (a few microns or less in width), reveals that due primarily to the presence of large demagnetizing fields at the sensor edges the magnetization is not uniform over the area of the pinned layer. FIG. 2B shows a perspective view of an SV sensor 250. The SV sensor 250 is formed of a sensor stripe 260 having a front edge 270 at the ABS and extending away from the ABS to a rear edge 272. Due to the large demagnetizing fields at the front edge 270 and the rear edge 272 of the sensor stripe 260, the desired perpendicular magnetization direction is achieved only at the center portion 280 of the pinned layer stripe, while the magnetization tends to be curled into a direction parallel to the ABS at the edges of the stripe. The extent of these curled regions is controlled by the magnetic stiffness of the pinned layer.

Furthermore, prior art AP-Pinned SV sensors use an AFM in order to pin the pinned layer magnetization. Most commonly used AFM materials have blocking temperatures (temperature at which the pinning field reaches zero Oe) near 200° C. This means that if the temperature of the SV sensor approaches this temperature, the pinned layer magnetization can change its orientation resulting in degraded SV sensor performance.

Although AP-Pinned SV sensors have large effective pinning fields because near cancellation of the magnetic moments of the two sub-layers results in a low net magnetic moment for the pinned layer, thermal stability is still a concern because the operating temperatures of these SV sensors in disk files can exceed 120° C. In addition, the AP-pinned layer structure is vulnerable to demagnetization during processing operations such as lapping.

Therefore there is a need for an SV sensor that increases the magnetic saturation of the pinned layer and reduces the sensitivity to demagnetizing fields particularly at the front and rear edges of the pinned layer stripe. In SV sensors that include AFM layers to provide exchange anisotropy fields to fix the pinned layer magnetization direction, there is a further need for an SV structure that reduces the temperature limitations imposed by the blocking temperature characteristics of the commonly used antiferromagnetic materials required in prior art SV sensors for providing pinning fields.

In any of the prior art sensors described above, the thickness of the spacer layer is chosen so that shunting of the sense current and a magnetic coupling between the free and pinned layer structures are minimized. This thickness is typically less than the mean free path of electrons conducted through the sensor. With this arrangement, a portion of the conduction electrons are scattered at the interfaces of the spacer layer with the pinned and free layer structures. When the magnetic moments of the pinned and free layer structures are parallel with respect to one another scattering is minimal and when their magnetic moments are antiparallel scattering is maximized. Changes in scattering changes the resistance of the spin valve sensor as a function of $\cos \Theta$, where Θ is the angle between the magnetic moments of the pinned and free layer structures. The sensitivity of the sensor is quantified as magnetoresistive coefficient dr/R where dr is the change in the resistance of the sensor as the magnetic moment of the free layer structure rotates from a position parallel with respect to the magnetic moment of the pinned layer structure to an antiparallel position with respect thereto and R is the resistance of the sensor when the magnetic moments are parallel.

The transfer curve of a spin valve sensor is defined by the aforementioned $\cos \Theta$ where Θ is the angle between the directions of the magnetic moments of the free and pinned layers. In a spin valve sensor subjected to positive and

negative magnetic signal fields from a moving magnetic disk, which are typically chosen to be equal in magnitude, it is desirable that positive and negative changes in the resistance of the spin valve read head above and below a bias point on the transfer curve of the sensor be equal so that the positive and negative readback signals are equal. When the direction of the magnetic moment of the free layer is substantially parallel to the ABS and the direction of the magnetic moment of the pinned layer is perpendicular to the ABS in a quiescent state (no signal from the magnetic disk) the positive and negative readback signals should be equal when sensing positive and negative fields from the magnetic disk.

Accordingly, the bias point should be located midway between the top and bottom of the transfer curve. When the bias point is located below the midway point the spin valve sensor is negatively biased and has positive asymmetry and when the bias point is above the midway point the spin valve sensor is positively biased and has negative asymmetry. When the readback signals are asymmetrical, signal output and dynamic range of the sensor are reduced. Readback asymmetry is defined as:

$$\frac{V_1 - V_2}{\max(V_1 \text{ or } V_2)}$$

For example, +10% readback asymmetry means that the positive readback signal V_1 is 10% greater than it should be to obtain readback symmetry. 10% readback asymmetry is acceptable in some applications. +10% readback asymmetry may not be acceptable in applications where the applied field magnetizes the free layer close to saturation. The designer strives to improve asymmetry of the readback signals as much as practical with the goal being symmetry.

The location of the transfer curve relative to the bias point is influenced by four major forces on the free layer of a spin valve sensor, namely a ferromagnetic coupling field H_{FC} between the pinned layer and the free layer, a net demagnetizing (demag) field H_D from the pinned layer, a sense current field H_I from all conductive layers of the spin valve except the free layer, a net image current field H_{IM} from the first and second shield layers.

Another factor that can affect readback asymmetry is positive magnetostriction of the free layer structure. If the free layer structure has positive magnetostriction and is subjected to compressive stress, there will be a stress-induced anisotropy that urges the magnetic moment of the free layer from the aforementioned position parallel to the ABS toward a position perpendicular to the ABS. The result is readback asymmetry. The compressive stress occurs after the magnetic head is lapped at the ABS to form the stripe height of the sensor of the read head. After lapping, the free layer is in compression and this, in combination with positive magnetostriction, causes the aforementioned readback asymmetry. It is interesting to note that if the free layer structure has negative magnetostriction in combination with compressive stress that the magnetic moment of the free layer is strengthened along the position parallel to the ABS. A high negative magnetostriction, however, is not desirable because it makes the magnetic moment of the free layer structure stiff and less responsive to field signals from the rotating magnetic disk. Accordingly, it is desirable that the magnetostriction of the free layer be zero or only slightly negative.

5

Unfortunately, magnetostriction of the free layer is difficult to control in present sputtering deposition systems. A typical free layer structure includes first and second free layers wherein the first free layer is cobalt iron and the second free layer is nickel iron with the first free layer interfacing the copper spacer layer for increasing the magnetoresistive coefficient dr/R of the sensor. Typical compositions of the free layers are cobalt iron ($\text{Co}_{90}\text{Fe}_{10}$) for the first free layer and nickel iron ($\text{Ni}_{83}\text{Fe}_{17}$) for the second free layer. When these layers are formed by sputter deposition the free layer structure invariably has an undesirable positive magnetostriction. In the past, the positive magnetostriction of the free layers has been accomplished by changing the composition of the free layers, such as reducing the iron content in the nickel iron and/or reducing the iron content in the cobalt iron. Since there is typically more than one nickel iron and cobalt iron layer in the spin valve sensor, this means that the targets in the sensor have to be changed in order to change the composition and lower the magnetostriction of the free layer structure.

Another problem found with sensors is that when the sensor has a very narrow track width, AP layers become unstable. More particularly, the AP layers tend to become unpinned because the pinning strength becomes weaker as the width of the layers is decreased. What is needed is a way to stabilize pinned layers in a narrow track width sensor so that magnetic orientations of the pinned layers do not flip under electrical or mechanical stress.

SUMMARY OF THE INVENTION

The present invention overcomes the drawbacks and limitations described above by providing a magnetic head having an air bearing surface (ABS). The head includes an antiparallel (AP) pinned layer structure having at least two pinned layers with magnetic moments that are self-pinned antiparallel to each other. The pinned layers are separated by an AP coupling layer. A bias layer with a pinned magnetic moment is spaced apart from the AP pinned layer structure. A free layer is positioned between the AP pinned layer structure and the bias layer. At least one of the pinned layers extends beyond track edges of the free layer in a direction parallel to the ABS.

In one embodiment, the pinned layer positioned closest to the free layer does not extend beyond the track edges of the free layer. In another embodiment, each of the pinned layers extends beyond the track edges of the free layer. Optional antiferromagnetic (AFM) layers can be positioned outside the track edges of the free layer in a direction parallel to the ABS (but not necessarily aligned with the free layer). The AFM layers pin a magnetic orientation of portions of the pinned layer closest thereto that are positioned outside the track edges of the free layer.

The reading head described herein may form part of a GMR head, a CPP GMR sensor, a CIP GMR sensor, a CPP tunnel valve sensor, etc. for use in a magnetic storage system.

BRIEF DESCRIPTION OF THE DRAWINGS

For a fuller understanding of the nature and advantages of the present invention, as well as the preferred mode of use, reference should be made to the following detailed description read in conjunction with the accompanying drawings.

FIG. 1A is an air bearing surface view, not to scale, of a prior art spin valve (SV) sensor.

6

FIG. 1B is an air bearing surface view, not to scale, of a prior art keepered SV sensor.

FIG. 2A is an air bearing surface view, not to scale, of a prior art AP-Pinned SV sensor.

FIG. 2B is a perspective view, not to scale, of a prior art AP-Pinned SV sensor.

FIG. 3 is a simplified drawing of a magnetic recording disk drive system.

FIG. 4 is a partial view of the slider and a merged magnetic head.

FIG. 5 is a partial ABS view, not to scale, of the slider taken along plane 5—5 of FIG. 4 to show the read and write elements of the merged magnetic head.

FIG. 6 is an enlarged isometric illustration, not to scale, of the read head with a spin valve sensor.

FIG. 7 is an ABS illustration of a CPP GMR sensor, not to scale, according to an embodiment of the present invention.

FIG. 8 is an ABS illustration of a CPP GMR sensor, not to scale, according to an embodiment of the present invention.

FIG. 9 is an ABS illustration of a CPP GMR sensor, not to scale, according to an alternate embodiment of the present invention.

FIG. 10 is an ABS illustration of a CPP GMR sensor, not to scale, according to another alternate embodiment of the present invention.

FIG. 11 is an ABS illustration of a CPP tunnel valve sensor, not to scale, according to an embodiment of the present invention.

FIG. 12 depicts an ABS view of a CPP tunnel valve sensor, not to scale, according to another embodiment.

BEST MODE FOR CARRYING OUT THE INVENTION

The following description is the best embodiment presently contemplated for carrying out the present invention. This description is made for the purpose of illustrating the general principles of the present invention and is not meant to limit the inventive concepts claimed herein.

Referring now to FIG. 3, there is shown a disk drive 300 embodying the present invention. As shown in FIG. 3, at least one rotatable magnetic disk 312 is supported on a spindle 314 and rotated by a disk drive motor 318. The magnetic recording on each disk is in the form of an annular pattern of concentric data tracks (not shown) on the disk 312.

At least one slider 313 is positioned near the disk 312, each slider 313 supporting one or more magnetic read/write heads 321. More information regarding such heads 321 will be set forth hereinafter during reference to FIG. 4. As the disks rotate, slider 313 is moved radially in and out over disk surface 322 so that heads 321 may access different tracks of the disk where desired data are recorded. Each slider 313 is attached to an actuator arm 319 by means way of a suspension 315. The suspension 315 provides a slight spring force which biases slider 313 against the disk surface 322. Each actuator arm 319 is attached to an actuator means 327. The actuator means 327 as shown in FIG. 3 may be a voice coil motor (VCM). The VCM comprises a coil movable within a fixed magnetic field, the direction and speed of the coil movements being controlled by the motor current signals supplied by controller 329.

During operation of the disk storage system, the rotation of disk 312 generates an air bearing between slider 313 and disk surface 322 which exerts an upward force or lift on the

slider. The air bearing thus counter-balances the slight spring force of suspension 315 and supports slider 313 off and slightly above the disk surface by a small, substantially constant spacing during normal operation.

The various components of the disk storage system are controlled in operation by control signals generated by control unit 329, such as access control signals and internal clock signals. Typically, control unit 329 comprises logic control circuits, storage means and a microprocessor. The control unit 329 generates control signals to control various system operations such as drive motor control signals on line 323 and head position and seek control signals on line 328. The control signals on line 328 provide the desired current profiles to optimally move and position slider 313 to the desired data track on disk 312. Read and write signals are communicated to and from read/write heads 321 by way of recording channel 325.

The above description of a typical magnetic disk storage system, and the accompanying illustration of FIG. 3 are for representation purposes only. It should be apparent that disk storage systems may contain a large number of disks and actuators, and each actuator may support a number of sliders.

FIG. 4 is a side cross-sectional elevation view of a merged magnetic head 400, which includes a write head portion 402 and a read head portion 404, the read head portion employing a dual spin valve sensor 406 of the present invention. FIG. 5 is an ABS view of FIG. 4. The spin valve sensor 406 is sandwiched between nonmagnetic electrically insulative first and second read gap layers 408 and 410, and the read gap layers are sandwiched between ferromagnetic first and second shield layers 412 and 414. In response to external magnetic fields, the resistance of the spin valve sensor 406 changes. A sense current (I_s) conducted through the sensor causes these resistance changes to be manifested as potential changes. These potential changes are then processed as readback signals by the processing circuitry 329 shown in FIG. 3.

The write head portion 402 of the magnetic head 400 includes a coil layer 422 sandwiched between first and second insulation layers 416 and 418. A third insulation layer 420 may be employed for planarizing the head to eliminate ripples in the second insulation layer caused by the coil layer 422. The first, second and third insulation layers are referred to in the art as an "insulation stack". The coil layer 422 and the first, second and third insulation layers 416, 418 and 420 are sandwiched between first and second pole piece layers 424 and 426. The first and second pole piece layers 424 and 426 are magnetically coupled at a back gap 428 and have first and second pole tips 430 and 432 which are separated by a write gap layer 434 at the ABS. Since the second shield layer 414 and the first pole piece layer 424 are a common layer this head is known as a merged head. In a piggyback head an insulation layer is located between a second shield layer and a first pole piece layer. First and second solder connections (not shown) connect leads (not shown) from the spin valve sensor 406 to leads (not shown) on the slider 313 (FIG. 3), and third and fourth solder connections (not shown) connect leads (not shown) from the coil 422 to leads (not shown) on the suspension.

FIG. 6 is an enlarged isometric ABS illustration of the read head 400 shown in FIG. 4. The read head 400 includes the spin valve sensor 406. First and second hard bias and lead layers 602 and 604 are connected to first and second side edges 606 and 608 of the spin valve sensor. This connection is known in the art as a contiguous junction and

is fully described in U.S. Pat. No. 5,018,037 which is incorporated by reference herein. The first hard bias and lead layers 602 include a first hard bias layer 610 and a first lead layer 612 and the second hard bias and lead layers 604 include a second hard bias layer 614 and a second lead layer 616. The hard bias layers 610 and 614 cause magnetic fields to extend longitudinally through the spin valve sensor 406 for stabilizing the magnetic domains therein. The spin valve sensor 406 and the first and second hard bias and lead layers 602 and 604 are located between the nonmagnetic electrically insulative first and second read gap layers 408 and 410. The first and second read gap layers 408 and 410 are, in turn, located between the ferromagnetic first and second shield layers 412 and 414.

The present invention provides a new sensor structure having an AFM in the passive area to pin the self-pinned layers, increasing their stability. Many types of heads can use the structure described herein, and the structure is particularly adapted to a CPP GMR sensor and a CPP tunnel valve sensor. In the following description, the track edges of the layers are defined by the track width (W). The sensor height is in a direction into the face of the paper. Unless otherwise described, thicknesses of the individual layers are taken perpendicular to the plane of the associated layer and are provided by way of example only and may be larger and/or smaller than those listed. Similarly, the materials listed herein are provided by way of example only, and one skilled in the art will understand that other materials may be used without straying from the spirit and scope of the present invention.

CPP GMR

FIG. 7 depicts an ABS view of a CPP GMR sensor 700 according to one embodiment. "CPP" means that the sensing current (I_s) flows from one shield to the other shield in a direction perpendicular to the plane of the layers forming the sensor 700.

As shown in FIG. 7, a first shield layer (S1) 702 is formed on a substrate (not shown). The first shield layer 702 can be of any suitable material, such as permalloy (NiFe).

Seed layers are formed on the first shield layer 702. The seed layers aid in creating the proper growth structure of the layers above them. Illustrative materials formed in a stack from the first shield layer 702 are a layer of Ta (SL1) 704, a layer of NiFeCr (SL2) 706, a layer of NiFe (SL3) 708 and a layer of PtMn (SL4) 710. Illustrative thicknesses of these materials are Ta (30 Å), NiFeCr (20 Å), NiFe (8 Å), and PtMn (30 Å). Note that the stack of seed layers can be varied, and layers may be added or omitted based on the desired processing parameters.

Then an antiparallel (AP) pinned layer structure 712 is formed above the seed layers. As shown in FIG. 7, first and second AP pinned magnetic layers, (AP1) and (AP2) 714, 716, are separated by a thin layer of an antiparallel coupling (APC) material 718 such that the magnetic moments of the AP pinned layers 714, 716 are self-pinned antiparallel to each other. The pinned layers 714, 716 have a property known as magnetostriction. The magnetostriction of the pinned layers 714, 716 is very positive. The sensor 700 is also under compressive stresses because of its geometry at the ABS, and the configuration of the layer is such that it produces very large compressive stress. The combination of positive magnetostriction and compressive stress causes the pinned layers 714, 716 to develop a magnetic anisotropy that is in a perpendicular direction to the track width. This magnetic coupling through the Ru spacer causes the pinned layers 714, 716 to have antiparallel-oriented magnetizations.

The pinned layer structure in turn stabilizes the bias layer (described below) via exchange coupling.

In the embodiment shown in FIG. 7, the preferred magnetic orientation of the pinned layers 714, 716 is for the first pinned layer 714, into the face of the structure depicted (perpendicular to the ABS of the sensor 700), and out of the face for the second pinned layer 716. Also preferably, pinned layer structure 712 has about a zero net magnetic moment. Illustrative materials for the pinned layers 714, 716 are CoFe_{10} (90% Co, 10% Fe), CoFe_{50} (50% Co, 50% Fe), etc. separated by a Ru layer 718. Illustrative thicknesses of the first and second pinned layers 714, 716 are between about 10 Å and 25 Å. The Ru layer 718 can be about 5–15 Å, but is preferably selected to provide a saturation field above about 10 KOe. In a preferred embodiment, each of the pinned layers 714, 716 is about 18 Å with an Ru layer 718 therebetween of about 8 Å.

Because the pinning strength of the pinned layers 714, 716 becomes weaker as the width of the layers is decreased, the magnetic orientations of the pinned layers 714, 716 tend to become unpinned under electrical/mechanical stress. To overcome this tendency to flip, the lower pinned layer 714 is made wider than the track width W . This is permissible because the pinned layers 714, 716 do not affect the effective track width W of the sensor 700.

As the portions of the pinned layers 714, 716 in the track width W try to flip under electrical/mechanical stress, the areas of the lower pinned layer 714 outside the track edges of the sensor prevents the magnetic orientations of the pinned layers 714, 716 from flipping. Because the lower pinned layer 714 is longer, the pinned layers 714, 716 have stronger AP pinning. This is due in part to several reasons. Pinning has to do with magnetostriction and stress. The width W of the sensor is very long compared to its height (into the page). This makes the compressive stress larger, which in combination with positive magnetostriction of these layers 714, 716, results in strong pinning in this kind of design.

In addition to the improvement provided by the longer lower pinned layer 714, outer portions of pinned layer structure 712 can be pinned by an antiferromagnetic layer (AFM) 719. The pinning by the AFM layer 719 creates interlayer exchange coupling that carries over to the portions of the pinned layers 714, 716 positioned within the track width. In particular, the pinned layers 714, 716 are exchange coupled with each other, the portions of the pinned layers 714, 716 inside the track width are exchange coupled with the portions of the pinned layers 714, 716 outside the track width, and the portions of the pinned layers 714, 716 outside the track width are exchange coupled with the AFM layer 719. Thus, the effects of the AFM layer 719 travel throughout the pinned layers 714, 716. The zero net moment of the pinned layer structure 712 coupled with the additional pinning by the AFM layer 719 assures strong pinning. In fact, the pinned layers 714, 716 are pinned so strongly that virtually no external magnetic or electrical force will be able to disrupt the magnetic orientations of the pinned layers 714, 716.

The AFM layer 719 is spaced apart from the portions of the sensor 700 within the track width because otherwise the AFM layer 719 would shunt current. Preferably, the space between the AFM layer 719 and the track edges of the sensor is about 0.1 micron or more. The gap can be smaller, but the structure will be harder to process. The effects of the AFM layer 719 are enhanced because the AFM layer 719 is positioned outside the track width, and therefore stays cooler because no current flows through it. This design provides a

further advantage in that because the AFM layer 719 is not positioned in the sensor stack, thus reducing the gap of the sensor. Preferred materials for the AFM layer 719 are PtMn, IrMn, etc. The thickness of the AFM layer 719 can be about 100–150 Å if it is constructed from PtMn, and about 50–80 Å if it is constructed from IrMn, regardless of the thicknesses of the pinned layers 714, 716. The thickness of the AFM layer 719 may be varied because the net moment of the pinned layer structure 712 is about zero.

A first spacer layer (SP1) 720 is formed above the pinned layer structure 712. Illustrative materials for the first spacer layer 720 include Cu, CuO_x , $\text{Cu/CoFeO}_x/\text{Cu}$ stack, etc. The first spacer layer 720 can be about 10–30 Å thick, preferably about 20 Å.

A free layer (FL) 722 is formed above the first spacer layer 720. The magnetic moment of the free layer 722 is soft and so is susceptible to reorientation from external magnetic forces, such as those exerted by data on disk media. The relative motion of magnetic orientation of the free layer 722 when affected by data bits on disk media creates variations in the sensing current flowing through the sensor 700, thereby creating the signal. Exemplary materials for the free layer 722 are CoFe/NiFe stack, etc. An illustrative thickness of the free layer 722 is about 10–40 Å.

The magnetic orientation of the free layer 722 must be preset during manufacture, otherwise the orientation will be unstable and could move around at random, resulting in a “scrambled” or noisy signal. This instability is a fundamental property of soft materials, making them susceptible to any external magnetic perturbations. Thus, the magnetic orientation of the free layer 722 should be stabilized so that when its magnetic orientation moves, it consistently moves around in a systematical manner rather than a random manner. The magnetic orientation of the free layer 722 should also be stabilized so that it is less susceptible to reorientation, i.e., reversing. The structure disclosed stabilizes the free layer 722.

A second spacer layer (SP2) 724 is formed above the free layer 722. Illustrative materials for the second spacer layer 724 are Ta, Ru, Ta/Ru stack, Cu, etc. An exemplary thickness of the second spacer layer 724 is about 20–30 Å.

An in-stack bias layer (BL) 726 is formed above the second spacer layer 724. The magnetization of the bias layer 726 is pinned parallel to the track width, making the bias layer 726 act as a permanent magnet. The bias layer 726 stabilizes the free layer 722 through exchange coupling. This phenomenon is similar to the AP coupling of the pinned layers, except that the second spacer layer 724 must not be too thin or the free and bias layers may become permanently pinned and the head rendered practically ineffective.

Exemplary materials for the bias layer 726 are NiFe_{10} , CoNiNb , NiFeX ($X+\text{Cr}$, Mo , Rh , etc.), etc. An illustrative thickness of the bias layer 726 is about 10–40 Å, and is preferably selected such that it has a magnetic thickness comparable to the magnetic thickness of the free layer 722 to provide a flux closed structure where the magnetic poles at the free layer edges are eliminated. Also note that where NiFe or NiFeX is used, the Ni/Fe ratio is preferably kept at about $>90/10$ to obtain a large negative magnetostriction, e.g., about -2×10^{-5} . This magnetostriction together with compressive stress yields a H_k of greater than about 750 Oe at the free layer 722, and preferably about 1000 Oe at the bias layer 726.

The thickness of the second spacer layer 724 is constructed such that the magnetic field created by the bias layer 726 enters the free layer 722, stabilizing the magnetic orientation of the free layer 722, preferably so that the

magnetizations of the free and bias layers **722**, **726** are antiparallel. Such thickness of the second spacer layer **724** in the exemplary embodiment shown in FIG. 7 is about 20–30 Å thick. Also, a magnetic coupling is created between the free and bias layers **722**, **726** through the second spacer layer **724**, which enhances the stabilizing effect. Note that the magnetization of the free layer **722** remains soft in spite of the magnetic field of the bias layer **726**, thereby maintaining sufficient sensitivity necessary for reading magnetic media.

The magnetization of the bias layer **726** is preferably pinned parallel to the track width as opposed to perpendicular to the ABS. This can be accomplished by causing the bias layer **726** to have a negative magnetostriction by using other materials, such as those listed above, and preferably having a >90% Ni content. Further, Cr makes the material even more negative. When Nb is added, the material becomes amorphous (not crystalline), causing it to have a more negative magnetostriction. The negative magnetostriction in combination with large compressive stress (created by the geometry of the layer) creates a magnetic anisotropy which is parallel to the track width *W*, which in turn causes the magnetic orientation of the bias layer **726** to be pinned parallel to the track width.

A cap (CAP) **728** is formed above the bias layer **726**. Exemplary materials for the cap **728** are Ta, Ta/Ru stack, etc. An illustrative thickness of the cap **728** is 20–30 Å.

A second shield layer (S2) **730** is formed above the cap **728**. An insulative material **732** such as Al₂O₃ is formed on both sides of the sensor stack.

FIG. 8 depicts an ABS view of a CPP GMR sensor **800** according to another embodiment. The CPP GMR sensor **800** generally has the same configuration as the structure shown in FIG. 7, except that the bias layer **726** is pinned by an antiferromagnetic layer (AFM2) **734**. The antiferromagnetic layer **734** provides additional pinning to the bias layer **726** through exchange coupling, thereby stabilizing the bias layer **726**.

FIG. 9 depicts an ABS view of a CPP GMR sensor **900** according to one embodiment. The CPP GMR sensor **900** generally has the same configuration as the structure shown in FIG. 7, except that the upper pinned layer **716** also extends beyond the track edges of the sensor. While this structure provides similar advantages to the sensor **700** of FIG. 7, the configuration shown in FIG. 7 is more advantageous in that the magnetoresistance of the structure of FIG. 7 is larger, translating into more signal. The reason is that when the current flows through the sensor **900** of FIG. 9, the current will begin to spread out through the upper pinned layer **716**. Because the MR signal only comes from where the free layer **722**, spacer **720**, and upper pinned layer **716** are overlapping, any current is flowing into the outside areas of the upper pinned layer **716** results in signal loss (decreased dR).

FIG. 10 depicts an ABS view of a CPP GMR sensor **1000** according to another embodiment. The CPP GMR sensor **1000** generally has the same configuration as the structure shown in FIG. 9, except that the bias layer **726** is pinned by an antiferromagnetic layer (AFM2) **734**.

CPP Tunnel Valve

FIG. 11 depicts an ABS view of a CPP tunnel valve sensor **1100** according to one embodiment. The CPP tunnel valve sensor **1100** generally has the same configuration as the structure shown in FIG. 7, except that the first spacer layer **720** is formed of a dielectric barrier material, such as, Al₂O₃, AlO_x, MgO_x, etc. The first spacer layer **720** is very thin such that the electric current passing through the sensor **1100**

“tunnels” through the first spacer layer **720**. An illustrative thickness of the first spacer layer **720** is 3–6 Å.

FIG. 12 depicts an ABS view of a CPP tunnel valve sensor **1200** according to another embodiment. The CPP GMR sensor **1200** generally has the same configuration as the structure shown in FIG. 11, except that the bias layer **726** is pinned by an antiferromagnetic layer (AFM2) **734**.

CIP GMR

The concepts described above can also be adapted to create a CIP GMR sensor, as will be apparent to those skilled in the art. “CIP” means that the sensing current (*I_S*) flows from in a direction parallel to or “in” the plane of the layers forming the sensor. The CIP GMR sensor generally has the same configuration as the structures shown in FIGS. 7–12, except that leads of conventional materials and thicknesses are formed on opposite sides of the sensor and the sensor is sandwiched between an insulative material rather than shields.

While various embodiments have been described above, it should be understood that they have been presented by way of example only, and not limitation. For example, the structures and methodologies presented herein are generic in their application to all MR heads, AMR heads, GMR heads, spin valve heads, etc. Thus, the breadth and scope of a preferred embodiment should not be limited by any of the above-described exemplary embodiments, but should be defined only in accordance with the following claims and their equivalents.

What is claimed is:

1. A magnetic head having an air bearing surface (ABS), comprising:
 - an antiparallel (AP) pinned layer structure having at least two pinned layers with magnetic moments that are self-pinned antiparallel to each other, the pinned layers being separated by an AP coupling layer;
 - a bias layer spaced apart from the AP pinned layer structure, a magnetic moment of the bias layer being pinned; and
 - a free layer positioned between the AP pinned layer structure and the bias layer;
 wherein at least one of the pinned layers extends at least about 0.1 microns beyond each track edge of the free layer in a direction parallel to the ABS.
2. A magnetic head having an air bearing surface (ABS), comprising:
 - an antiparallel (AP) pinned layer structure having at least two pinned layers with magnetic moments that are self-pinned antiparallel to each other, the pinned layers being separated by an AP coupling layer;
 - a bias layer spaced apart from the AP pinned layer structure, a magnetic moment of the bias layer being pinned; and
 - a free layer positioned between the AP pinned layer structure and the bias layer;
 wherein at least one of the pinned layers extends beyond track edges of the free layer in a direction parallel to the ABS,
 - wherein the pinned layer positioned closest to the free layer does not extend beyond the track edges of the free layer.
3. A magnetic head having an air bearing surface (ABS), comprising:
 - an antiparallel (AP) pinned layer structure having at least two pinned layers with magnetic moments that are self-pinned antiparallel to each other, the pinned layers being separated by an AP coupling layer;

13

- a bias layer spaced apart from the AP pinned layer structure, a magnetic moment of the bias layer being pinned;
- a free layer positioned between the AP pinned layer structure and the bias layer; 5
- wherein at least one of the pinned layers extends beyond track edges of the free layer in a direction parallel to the ABS, and
- at least one antiferromagnetic (AFM) layer positioned outside the track edges of the free layer in a direction parallel to the ABS, each AFM layer being for pinning a magnetic orientation of portions of the pinned layer positioned outside the track edges of the free layer. 10
4. A head as recited in claim 3, wherein each of the pinned layers extends beyond the track edges of the free layer. 15
5. A magnetic storage system, comprising:
magnetic media;
at least one head for reading from and writing to the magnetic media, each head having:
a sensor having the structure recited in claim 3; 20
a write element coupled to the sensor;
a slider for supporting the head; and
a control unit coupled to the head for controlling operation of the head.
6. A magnetic head having an air bearing surface (ABS), 25 comprising:
an antiparallel (AP) pinned layer structure having at least two pinned layers with magnetic moments that are self-pinned antiparallel to each other, the pinned layers being separated by an AP coupling layer; 30
a bias layer spaced apart from the AP pinned layer structure, a magnetic moment of the bias layer being pinned;
a free layer positioned between the AP pinned layer structure and the bias layer; 35
wherein at least one of the pinned layers extends beyond track edges of the free layer in a direction parallel to the ABS, and
at least one antiferromagnetic (AFM) layer positioned outside the track edges of the free layer in a direction parallel to the ABS, each AFM layer being for pinning a magnetic orientation of portions of the pinned layer closest thereto and positioned outside the track edges of the free layer. 40
7. A head as recited in claim 6, wherein the head forms part of a CPP GMR sensor. 45
8. A head as recited in claim 6, wherein the head forms part of a CIP GMR sensor.
9. A head as recited in claim 6, wherein the head forms part of a tunnel valve sensor. 50
10. A head as recited in claim 6, wherein the head forms part of a GMR head.
11. A magnetic storage system, comprising: magnetic media;
at least one head for reading from and writing to the magnetic media, each head having: 55
a sensor having the structure recited in claim 6;
a write element coupled to the sensor;
a slider for supporting the head; and
a control unit coupled to the head for controlling operation of the head. 60
12. A magnetic head having an air bearing surface (ABS) comprising:
an antiparallel (AP) pinned layer structure having at least two pinned layers with magnetic moments that are self-pinned antiparallel to each other, the pinned layers being separated by an AP coupling layer; 65

14

- a free layer positioned towards the AP pinned layer structure;
wherein at least one of the pinned layers extends beyond track edges of the free layer in a direction parallel to the ABS, and
at least one antiferromagnetic (AFM) layer positioned outside the track edges of the free layer in a direction parallel to the ABS, each AFM layer being for pinning a magnetic orientation of portions of the pinned layer positioned outside the track edges of the free layer.
13. A magnetic head having an air bearing surface (ABS), comprising:
an antiparallel (AP) pinned layer structure having at least two pinned layers with magnetic moments that are self-pinned antiparallel to each other, the pinned layers being separated by an AP coupling layer; and
a free layer positioned towards the AP pinned layer structure;
wherein at least one of the pinned layers extends beyond track edges of the free layer in a direction parallel to the ABS,
wherein the pinned layer positioned closest to the free layer does not extend beyond the track edges of the free layer.
14. A magnetic head having an air bearing surface (ABS), comprising:
an antiparallel (AP) pinned layer structure having at least two pinned layers with magnetic moments that are self-pinned antiparallel to each other, the pinned layers being separated by an AP coupling layer;
a free layer positioned towards the AP pinned layer structure;
wherein at least one of the pinned layers extends beyond track edges of the free layer in a direction parallel to the ABS, and
at least one antiferromagnetic (AFM) layer positioned outside the track edges of the free layer in a direction parallel to the ABS, each AFM layer being for pinning a magnetic orientation of portions of the pinned layer closest thereto and positioned outside the track edges of the free layer.
15. A magnetic head having an air bearing surface (ABS), comprising:
an antiparallel (AP) pinned layer structure having at least two pinned layers with magnetic moments that are self-pinned antiparallel to each other, the pinned layers being separated by an AP coupling layer; and
a free layer positioned towards the AP pinned layer structure;
wherein at least one of the pinned layers extends at least about 0.1 microns beyond each track edge of the free layer in a direction parallel to the ABS.
16. A head as recited in claim 15, wherein the head forms part of a CPP GMR sensor.
17. A head as recited in claim 15, wherein the head forms part of a CIP GMR sensor.
18. A head as recited in claim 15, wherein the head forms part of a tunnel valve sensor.
19. A head as recited in claim 15, wherein the head forms part of a GMR head.
20. A head as recited in claim 15, wherein each of the pinned layers extends beyond the track edges of the free layer.