



US007021986B2

(12) **United States Patent
Thai**

(10) **Patent No.: US 7,021,986 B2**
(45) **Date of Patent: *Apr. 4, 2006**

(54) **BUBBLE GENERATING ASSEMBLY**

(75) Inventor: **Douglas Thai**, Walnut, CA (US)

(73) Assignee: **Arko Development Limited**, (HK)

(*) Notice: Subject to any disclaimer, the term of this patent is extended or adjusted under 35 U.S.C. 154(b) by 26 days.

This patent is subject to a terminal disclaimer.

(21) Appl. No.: **10/714,749**

(22) Filed: **Nov. 17, 2003**

(65) **Prior Publication Data**

US 2004/0127137 A1 Jul. 1, 2004

Related U.S. Application Data

(60) Continuation of application No. 10/072,196, filed on Feb. 7, 2002, now Pat. No. 6,659,830, which is a division of application No. 09/639,673, filed on Aug. 15, 2000, now Pat. No. 6,544,091, which is a continuation-in-part of application No. 09/551,814, filed on Apr. 18, 2000, now Pat. No. 6,315,627, which is a continuation-in-part of application No. 09/347,973, filed on Jul. 6, 1999, now Pat. No. 6,149,486, which is a continuation-in-part of application No. 09/277,512, filed on Mar. 26, 1999, now Pat. No. 6,102,764, which is a continuation-in-part of application No. 09/207,542, filed on Dec. 8, 1998, now Pat. No. 6,139,391.

(51) **Int. Cl.**
A63H 33/28 (2006.01)

(52) **U.S. Cl.** **446/15; 446/21**

(58) **Field of Classification Search** **446/15-21**
See application file for complete search history.

(56) **References Cited**

U.S. PATENT DOCUMENTS

2,041,423 A 5/1936 Mausolf

2,213,391 A	9/1940	Gamble	
2,412,732 A *	12/1946	Holman	40/408
2,527,935 A	10/1950	Joel, II	
2,547,825 A	4/1951	King	
2,587,537 A	2/1952	Scott	
2,632,281 A	3/1953	Schmidt, Jr.	
2,736,988 A	3/1956	Fisher	
2,987,847 A	6/1961	Jones	
3,071,888 A	1/1963	Knott	
3,210,790 A *	10/1965	Neumann	15/118
3,323,250 A	6/1967	Gibbons	
3,601,313 A	8/1971	Berg	
3,636,652 A *	1/1972	Dumont	446/15
3,731,412 A	5/1973	Winslow	
3,834,066 A *	9/1974	Vargas	446/21
4,016,673 A *	4/1977	Constance	446/18
4,246,717 A	1/1981	Wachtel	

(Continued)

FOREIGN PATENT DOCUMENTS

GB	2162077	1/1986
GB	2186199	8/1987
GB	2223687	4/1990

Primary Examiner—Bena Miller

(74) *Attorney, Agent, or Firm*—Raymond Sun

(57) **ABSTRACT**

A bubble producing assembly has a housing having an outlet, an air generator positioned on the housing, a bubble producing device positioned over the air generator, a first activator coupled to the air generator, a reservoir associated with the housing for storing a liquid, a pump system coupling the reservoir and the outlet, and a second activator coupled to the pump system for delivering the liquid from the reservoir out of the outlet. Thus, a user can use the first activator to generate air to produce bubbles, and can use the second activator to generate a stream of the liquid that can be aimed at the generated bubbles.

10 Claims, 24 Drawing Sheets

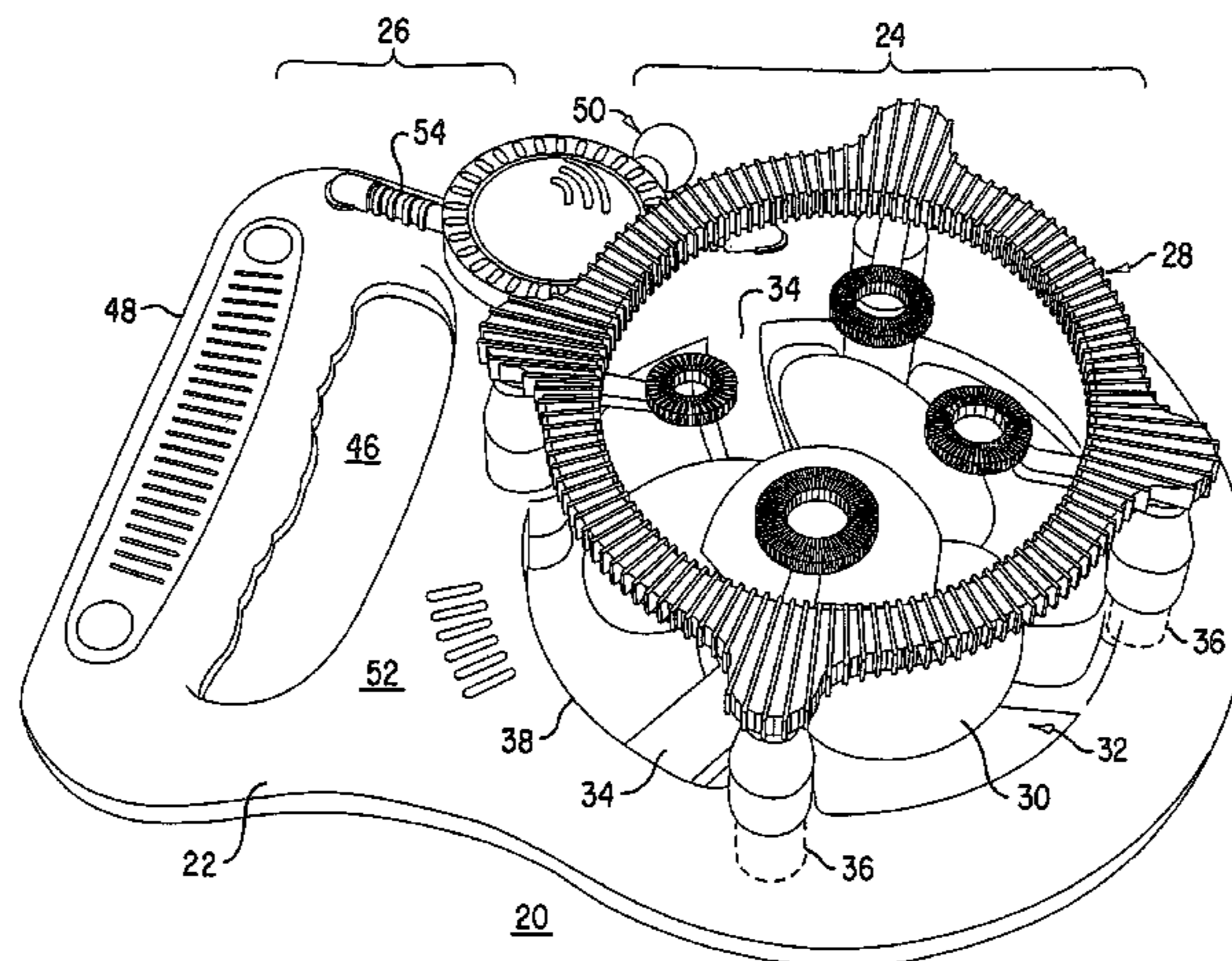

US 7,021,986 B2

Page 2

U.S. PATENT DOCUMENTS

D263,062	S	2/1982	Rasmussen				
4,447,982	A *	5/1984	Gushea	446/16			
4,467,552	A	8/1984	Jerrigan				
4,481,731	A *	11/1984	La Fata et al.	446/45			
4,603,021	A	7/1986	Urso				
4,700,965	A *	10/1987	Kinberg	280/304.2			
4,775,348	A	10/1988	Collins				
D304,466	S	11/1989	Glickman				
5,035,665	A	7/1991	Sheng				
5,234,129	A	8/1993	Lau				
D353,166	S *	12/1994	Kwak	D21/401			
5,462,469	A *	10/1995	Lei	446/15			
5,498,191	A	3/1996	DeMars				
5,613,890	A	3/1997	Demars				
5,653,620	A	8/1997	Lin				
5,664,947	A *	9/1997	Dietterich et al.	434/84			
5,695,379	A	12/1997	Ho				
5,746,636	A	5/1998	Cernansky et al.				
5,842,899	A	12/1998	Cernansky et al.				
6,200,184	B1 *	3/2001	Rich et al.	446/15			

* cited by examiner

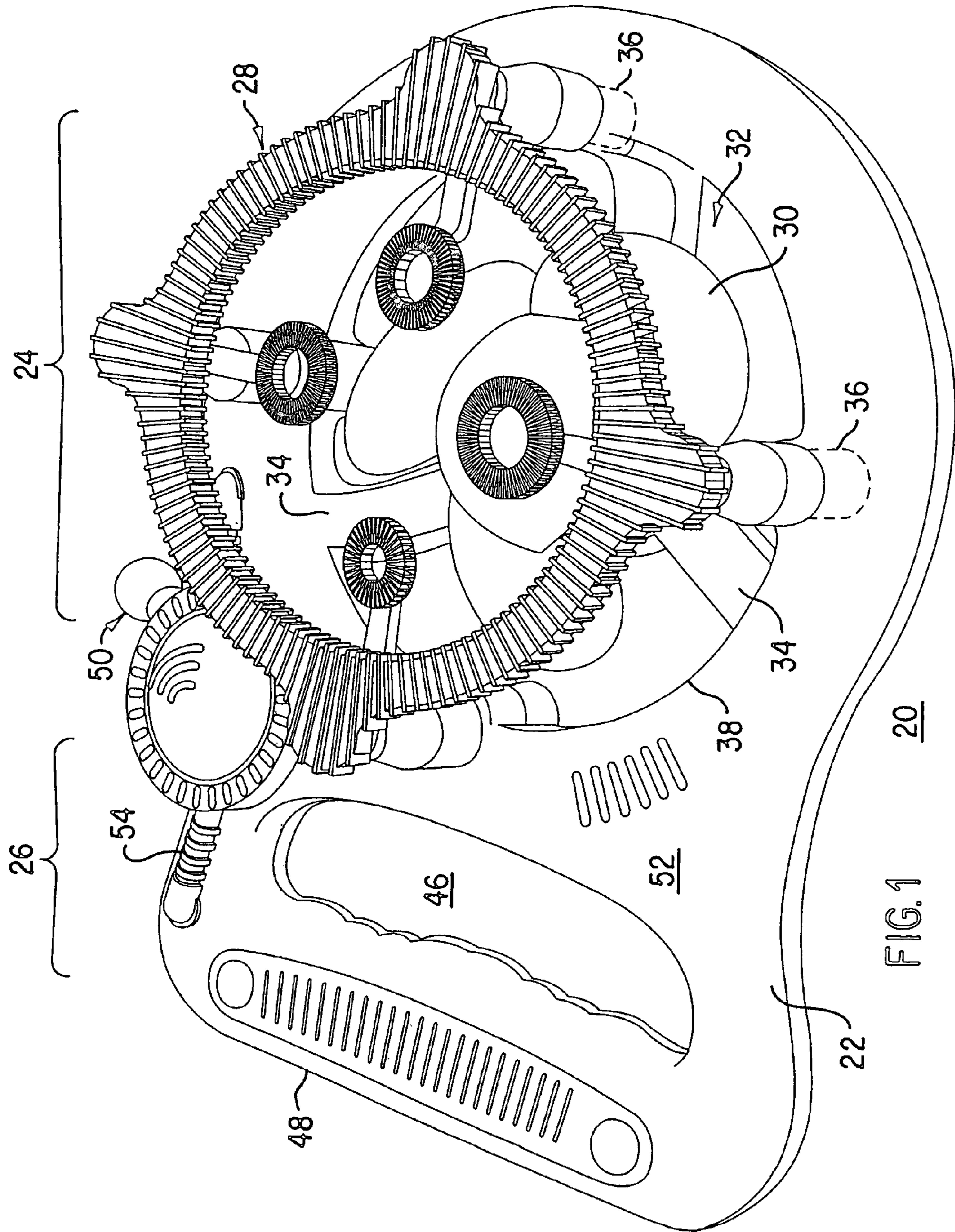

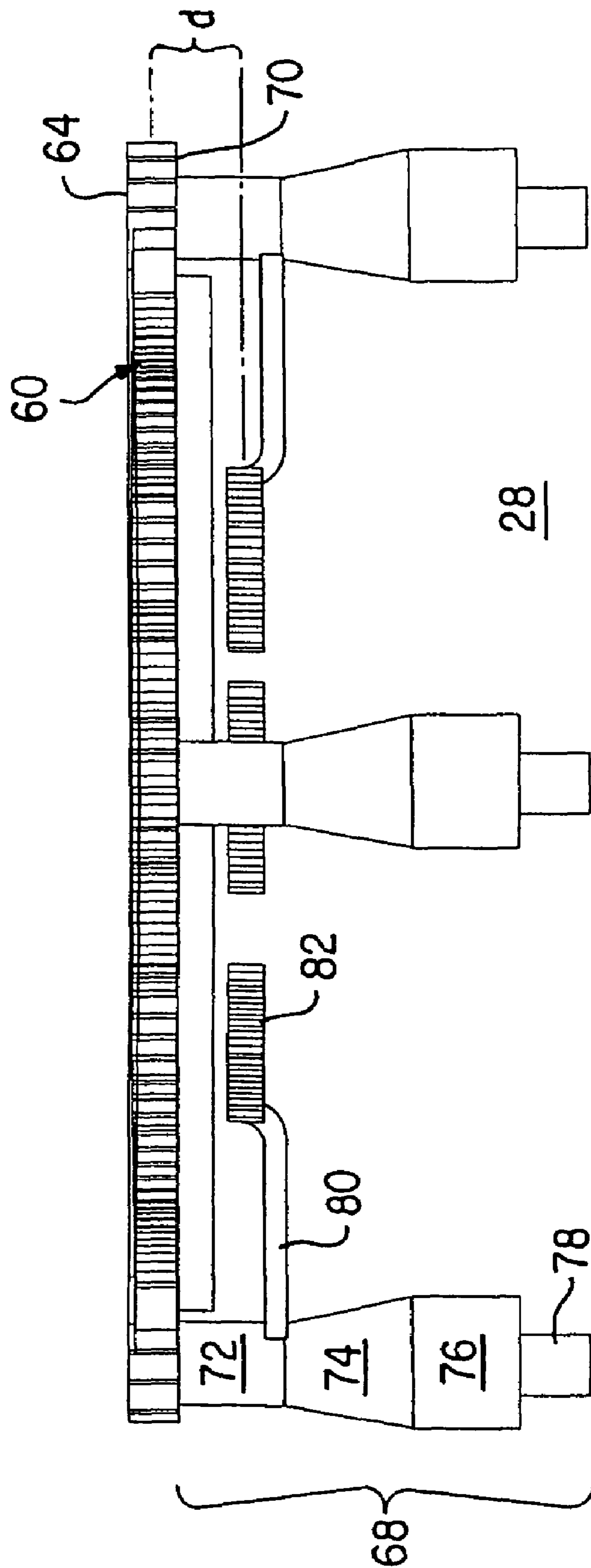

FIG. 3

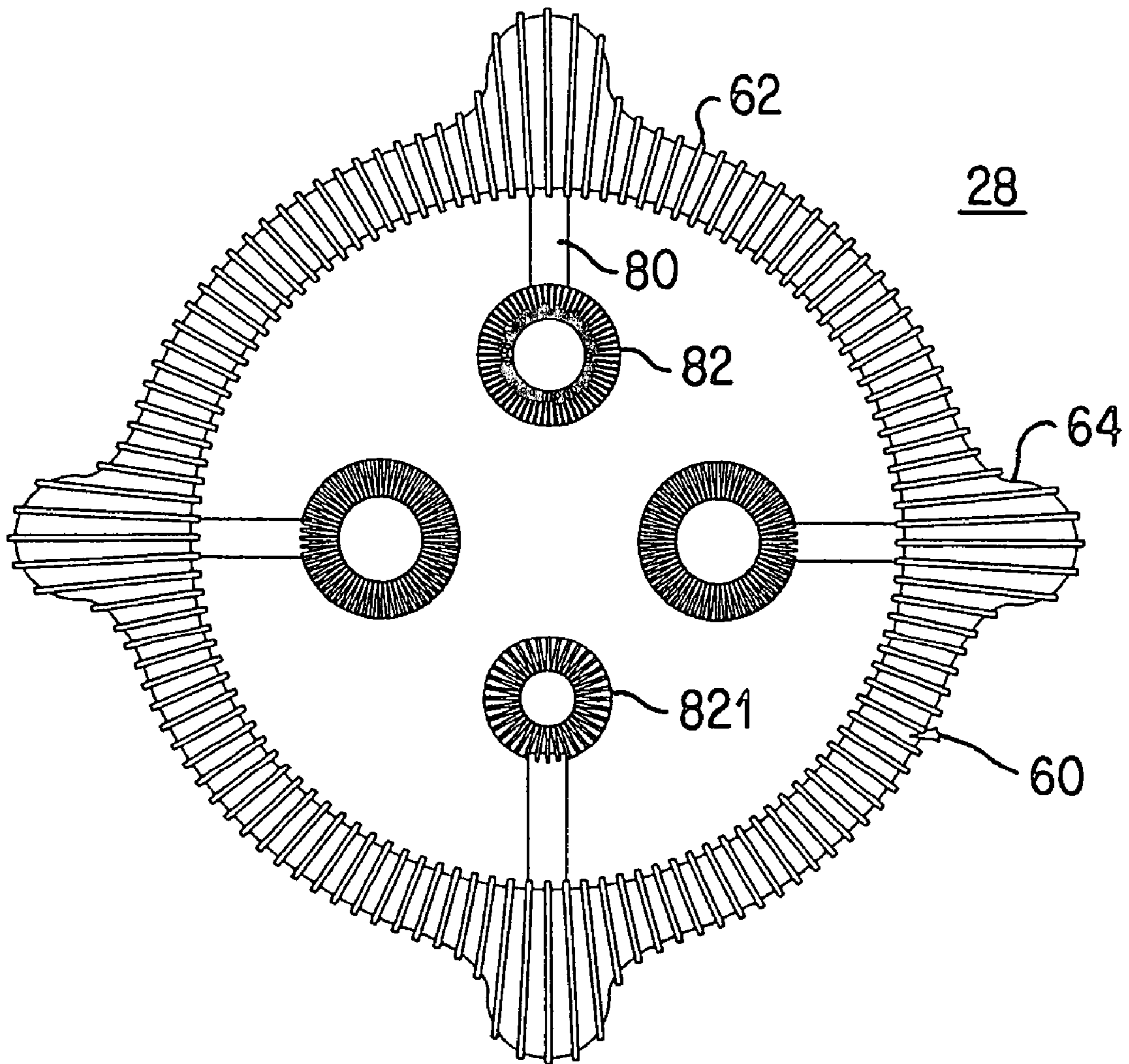

FIG. 4

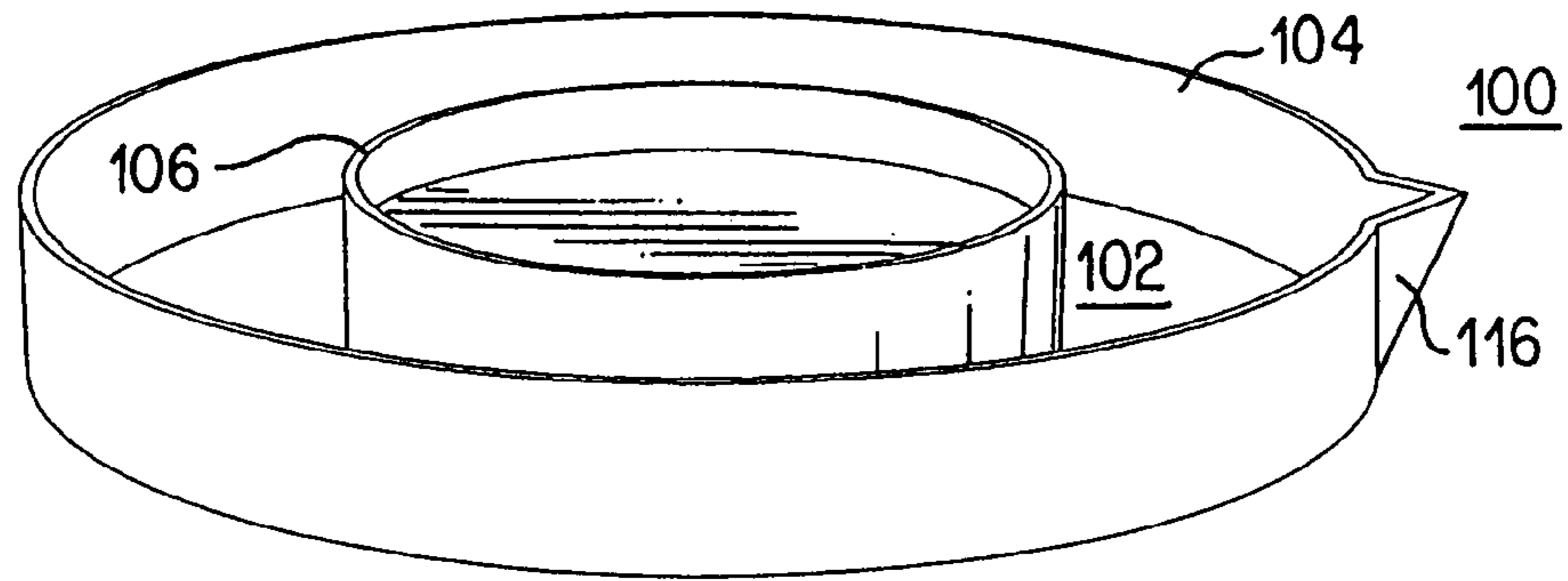

FIG. 5

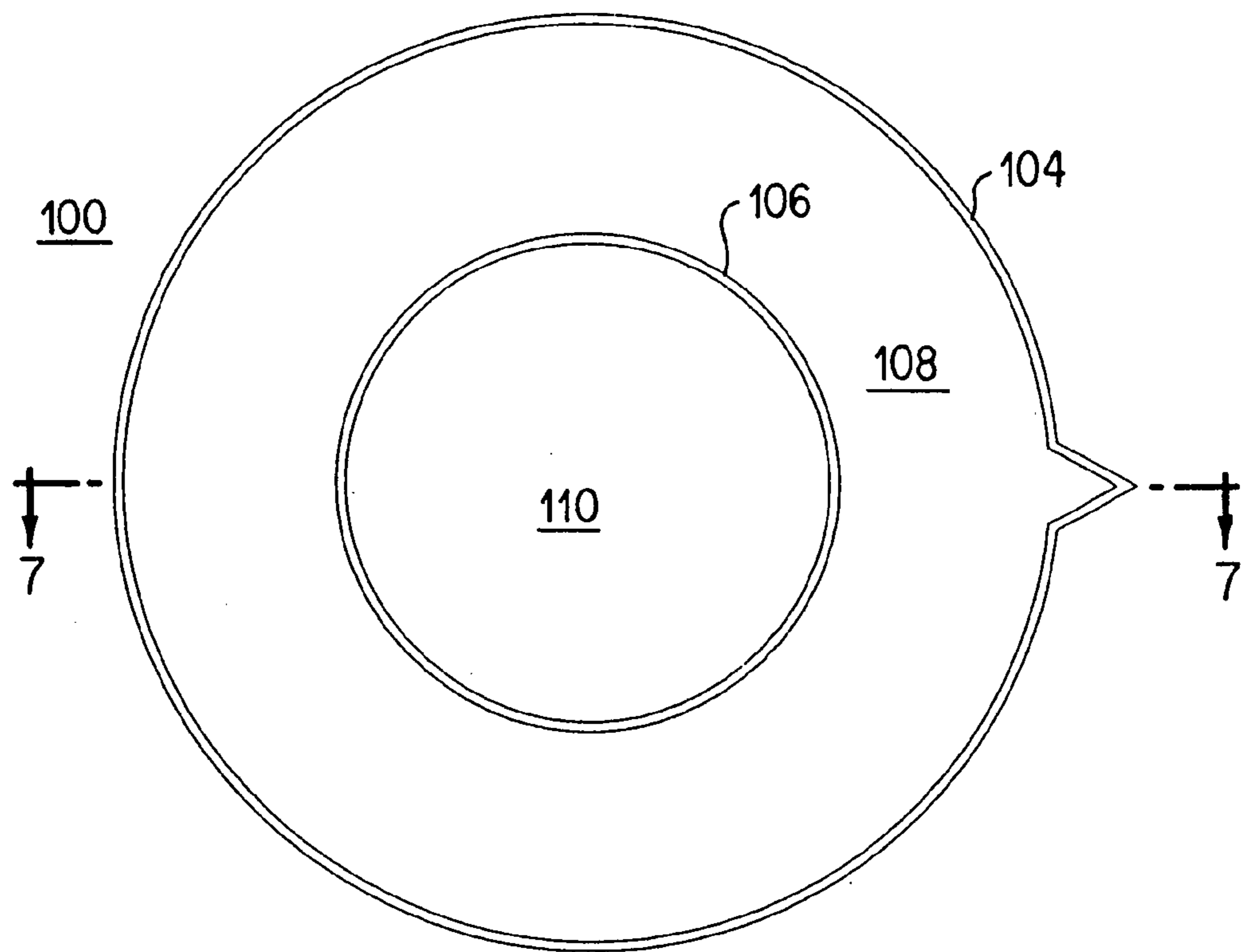

FIG. 6

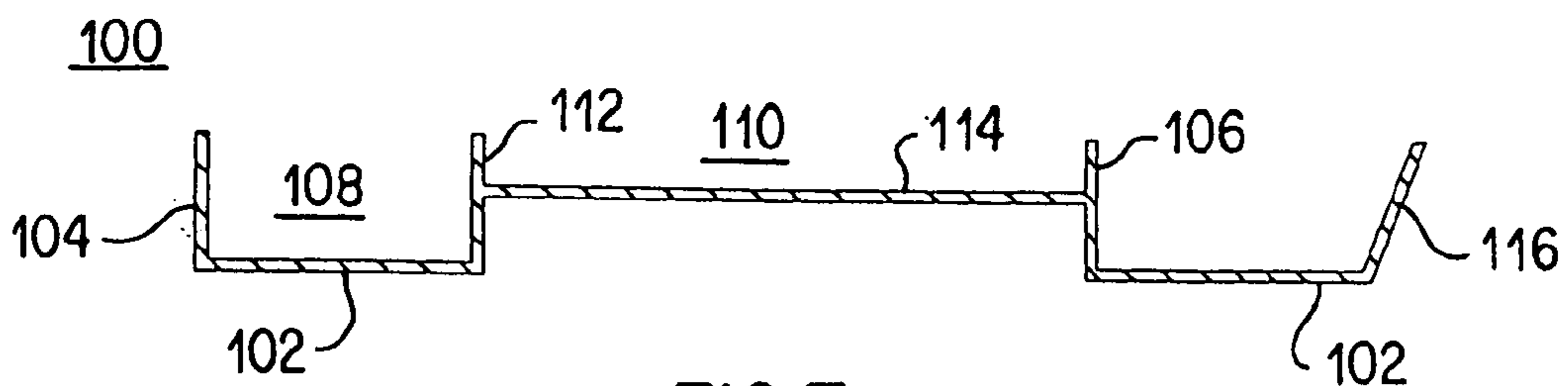

FIG. 7

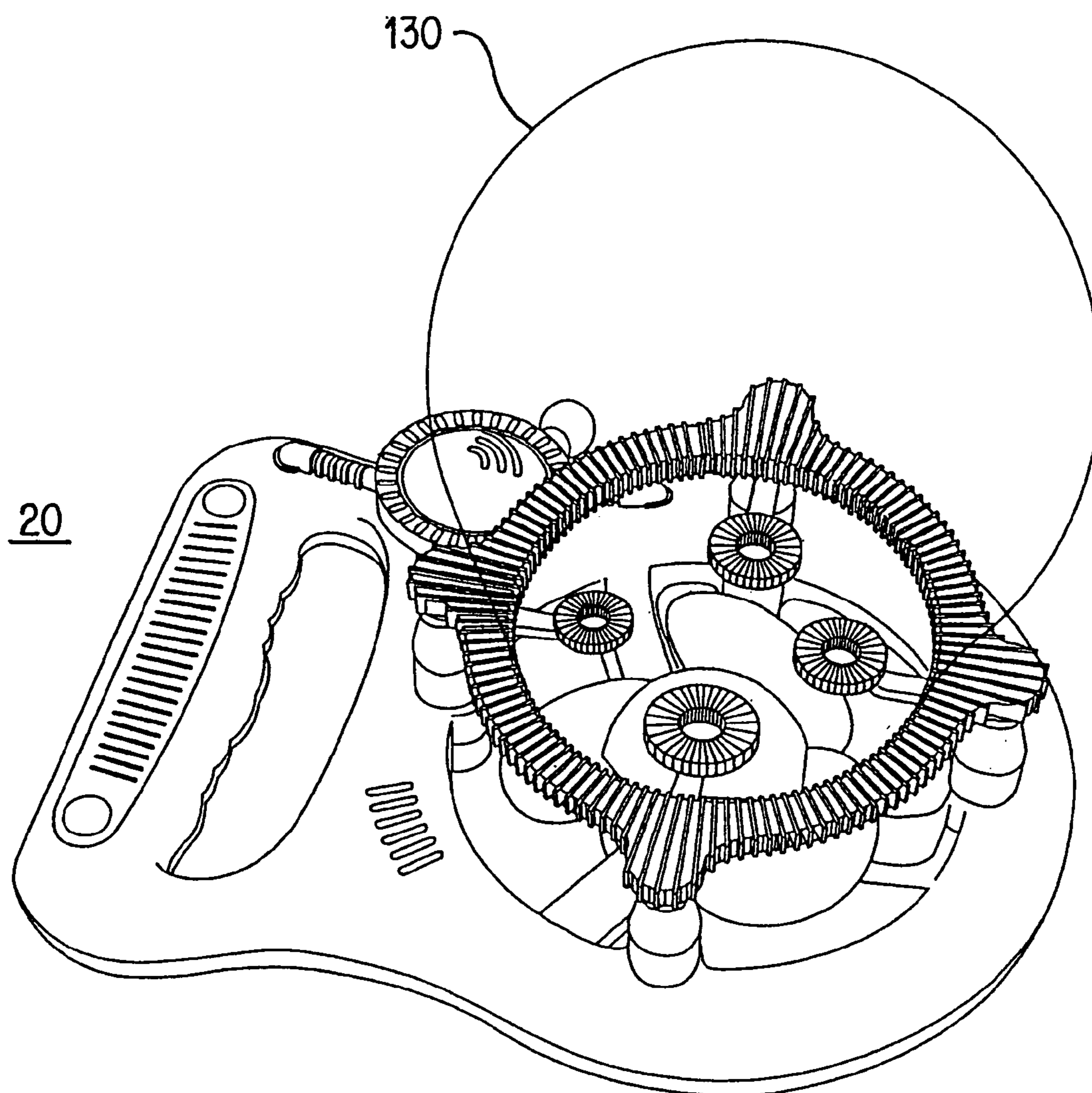

FIG. 8A

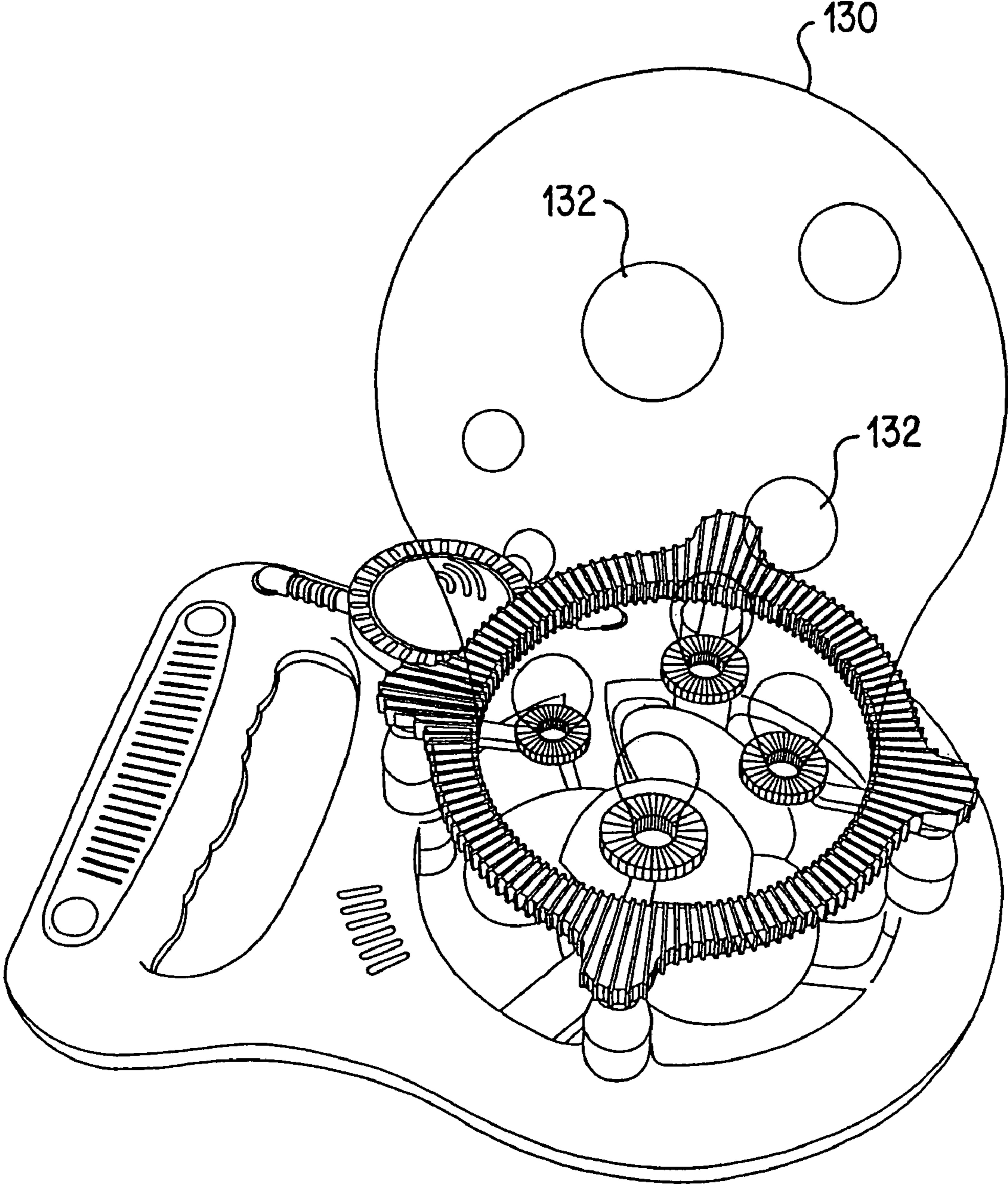

FIG. 8B

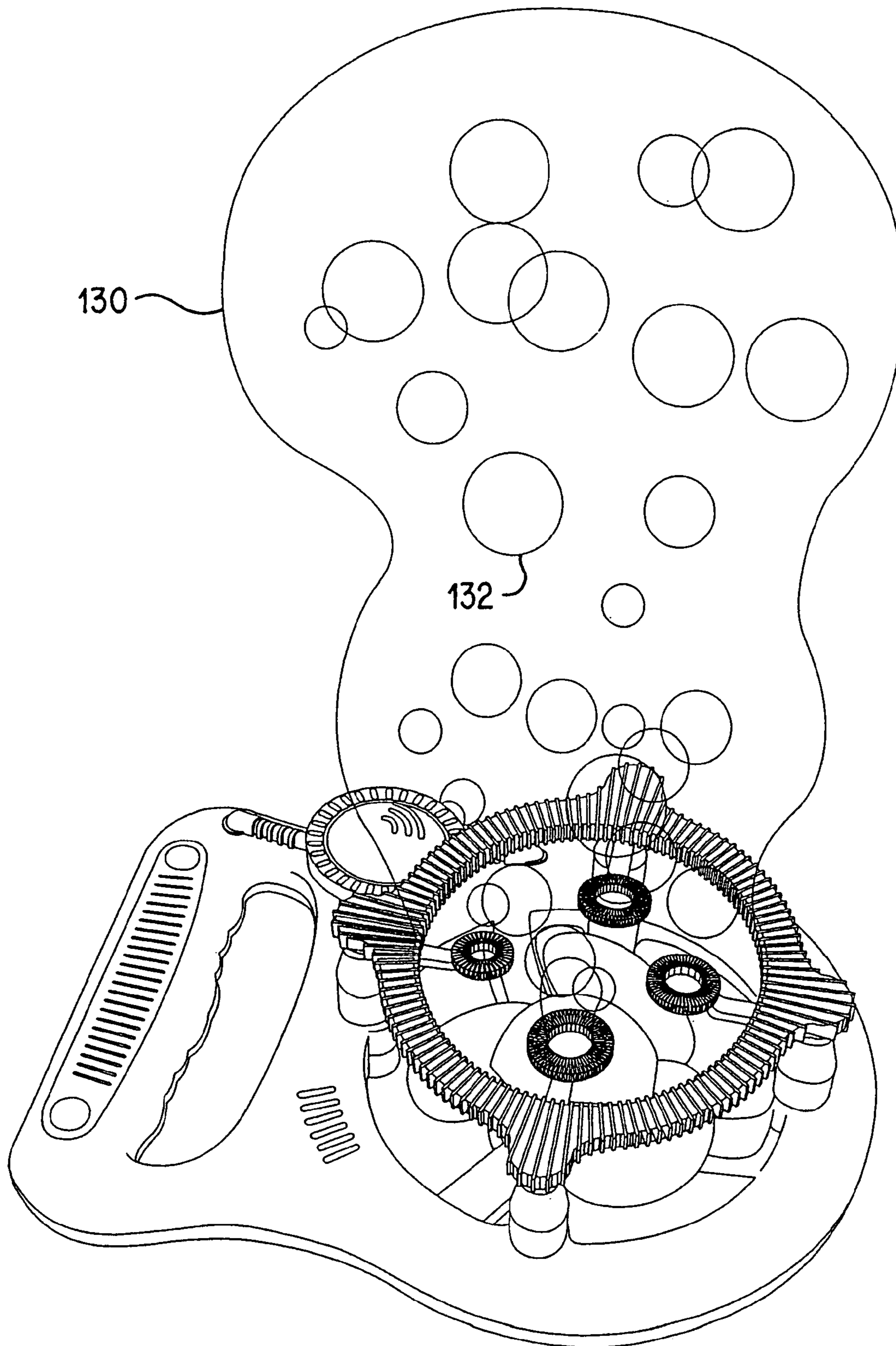

FIG. 8C

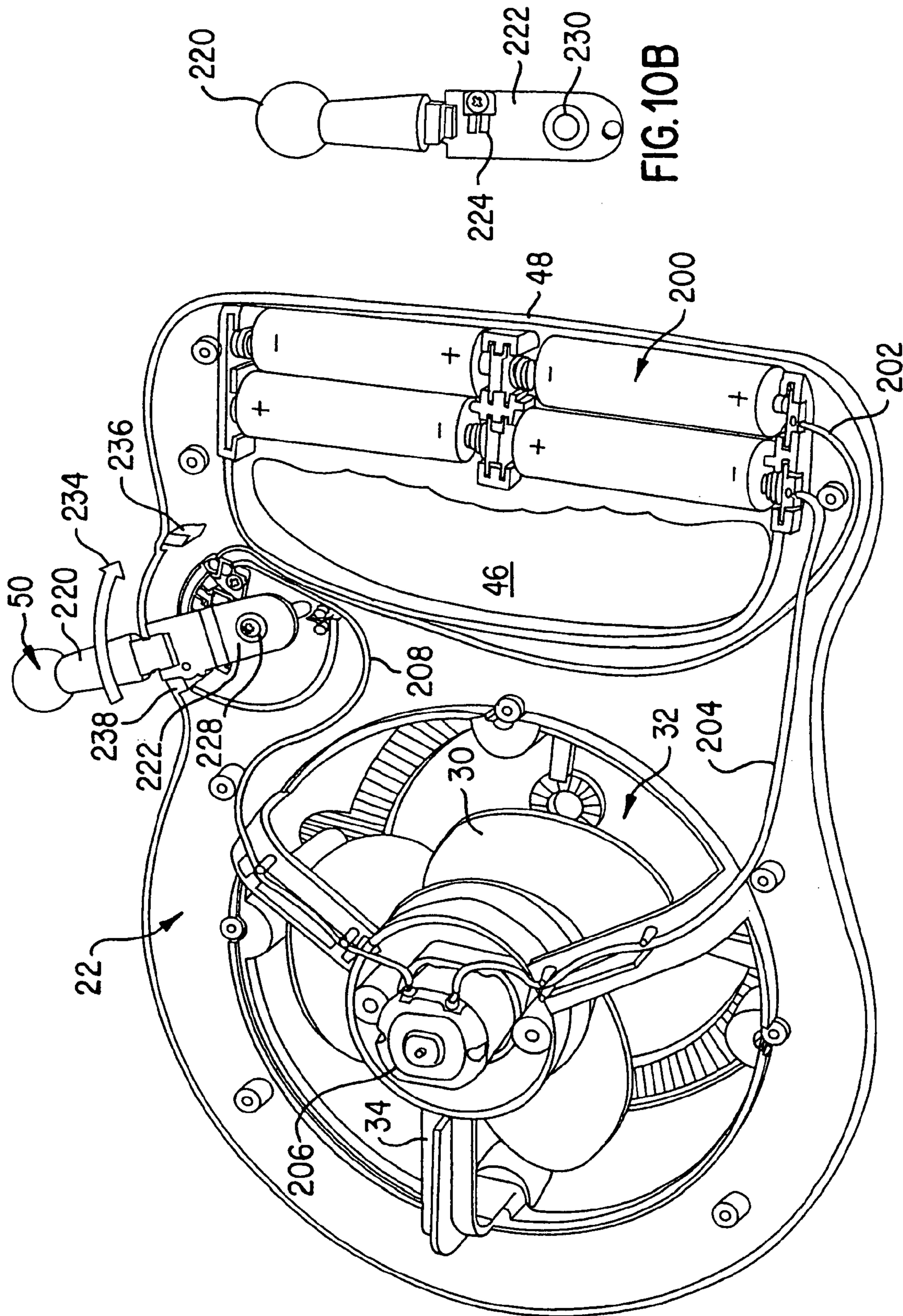

FIG. 9

FIG. 10B

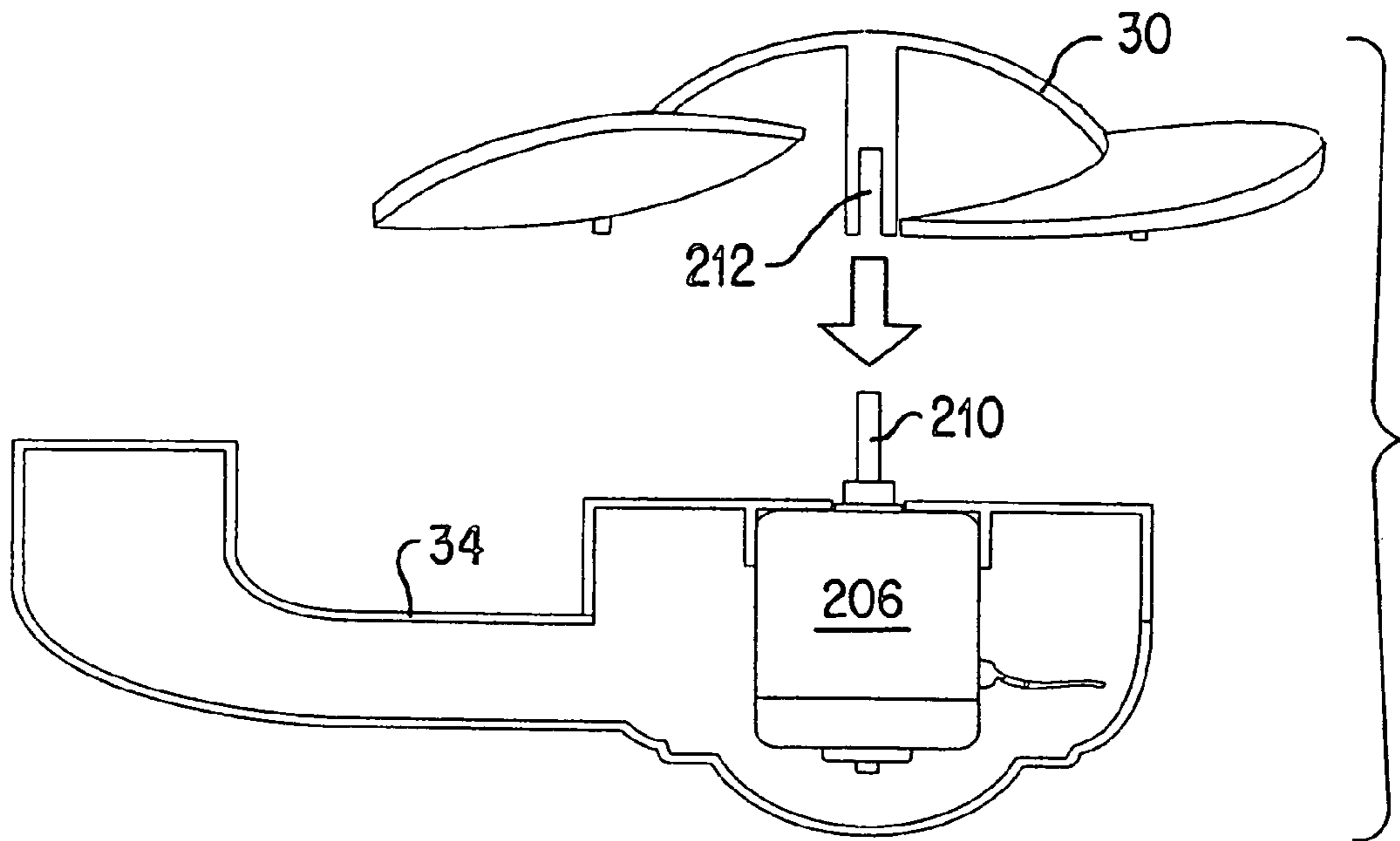

FIG. 11

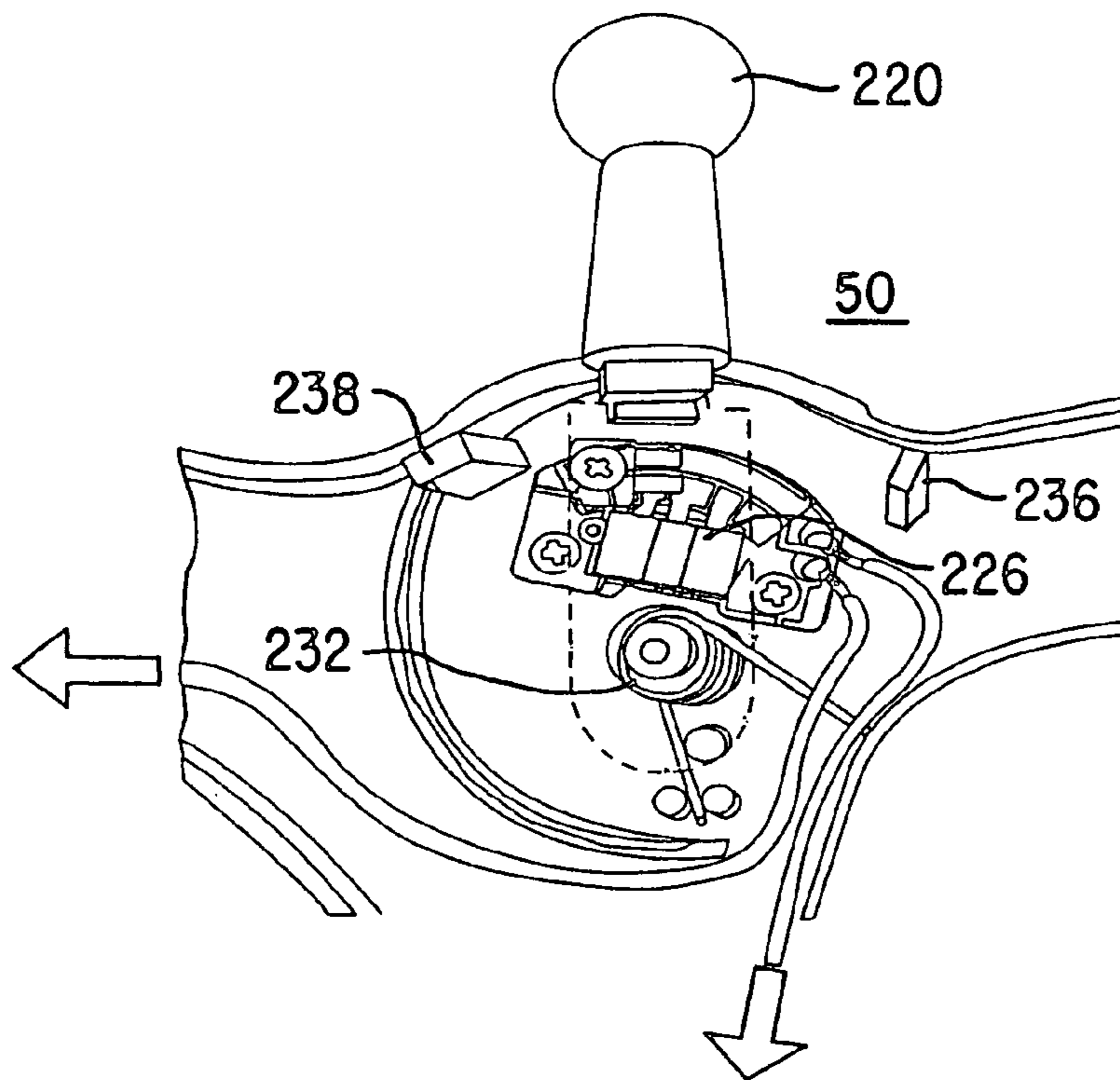

FIG. 10A

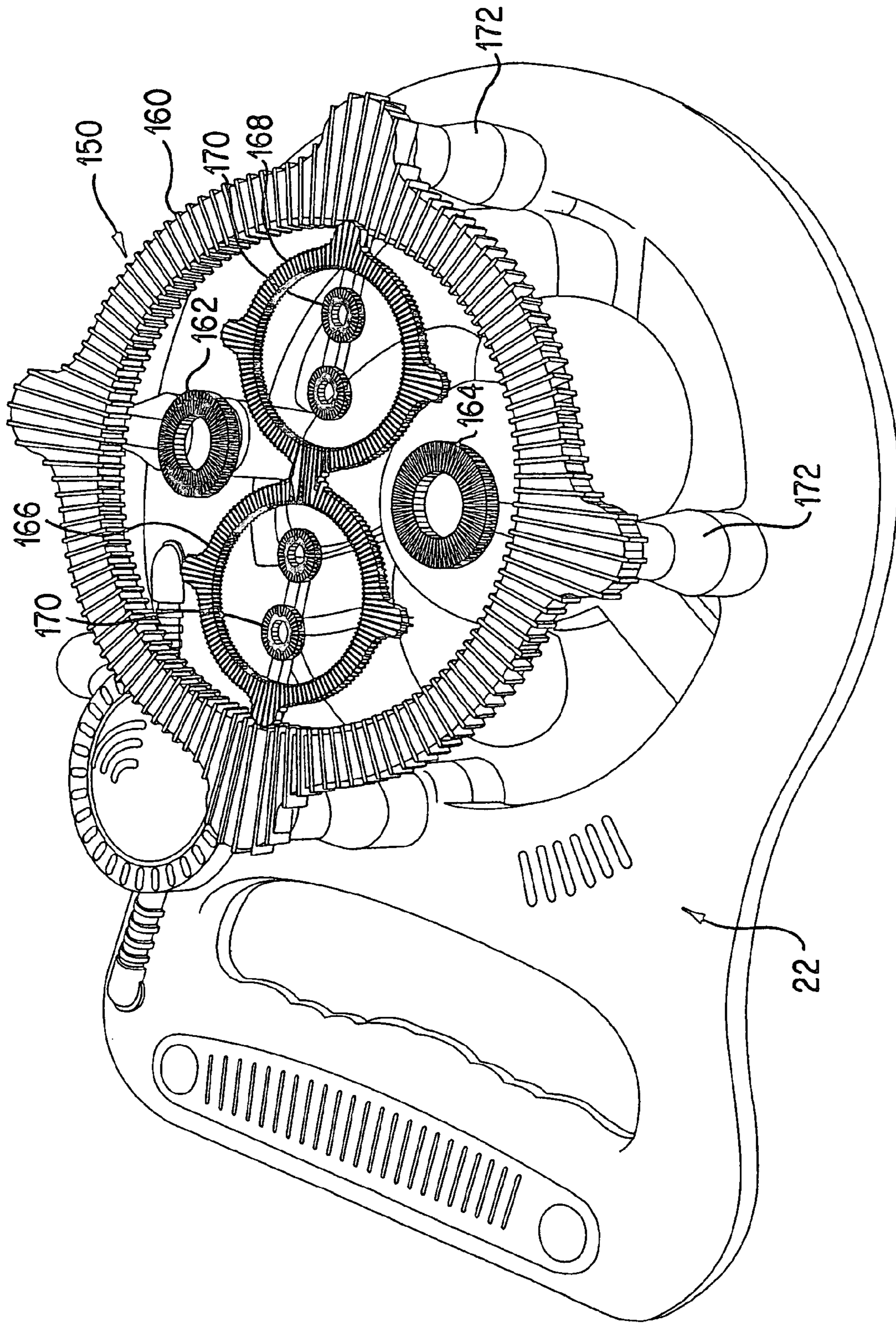

FIG. 12

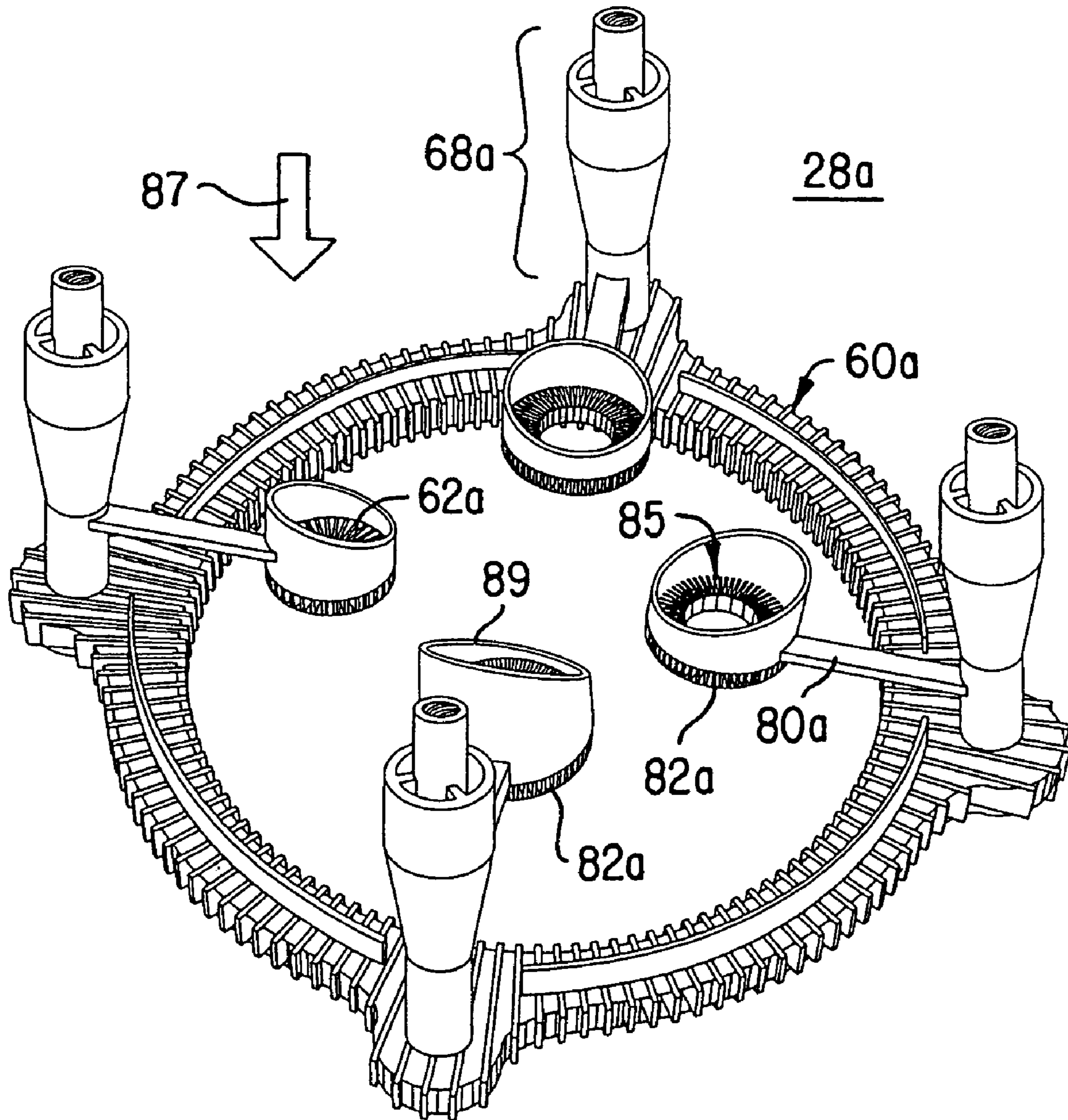

FIG. 13

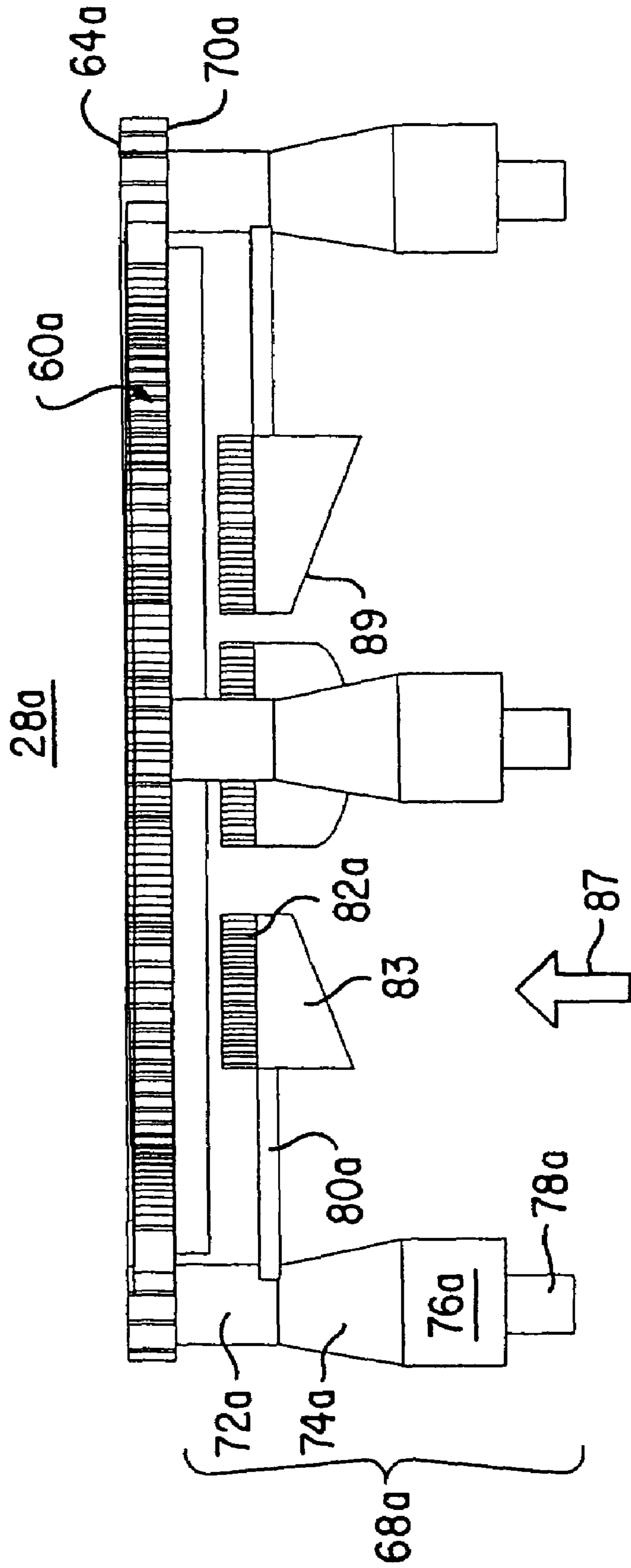

FIG. 14

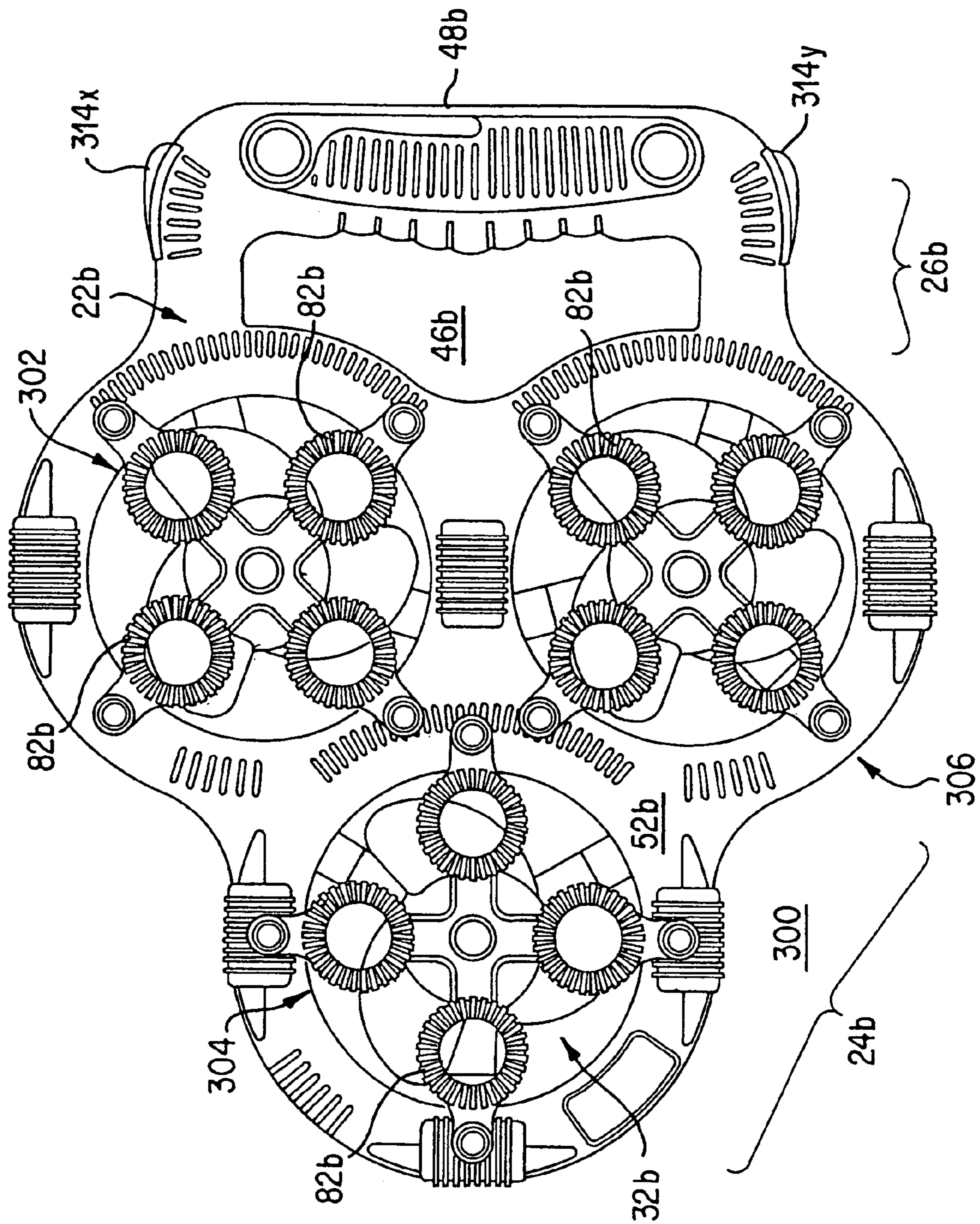

FIG.15

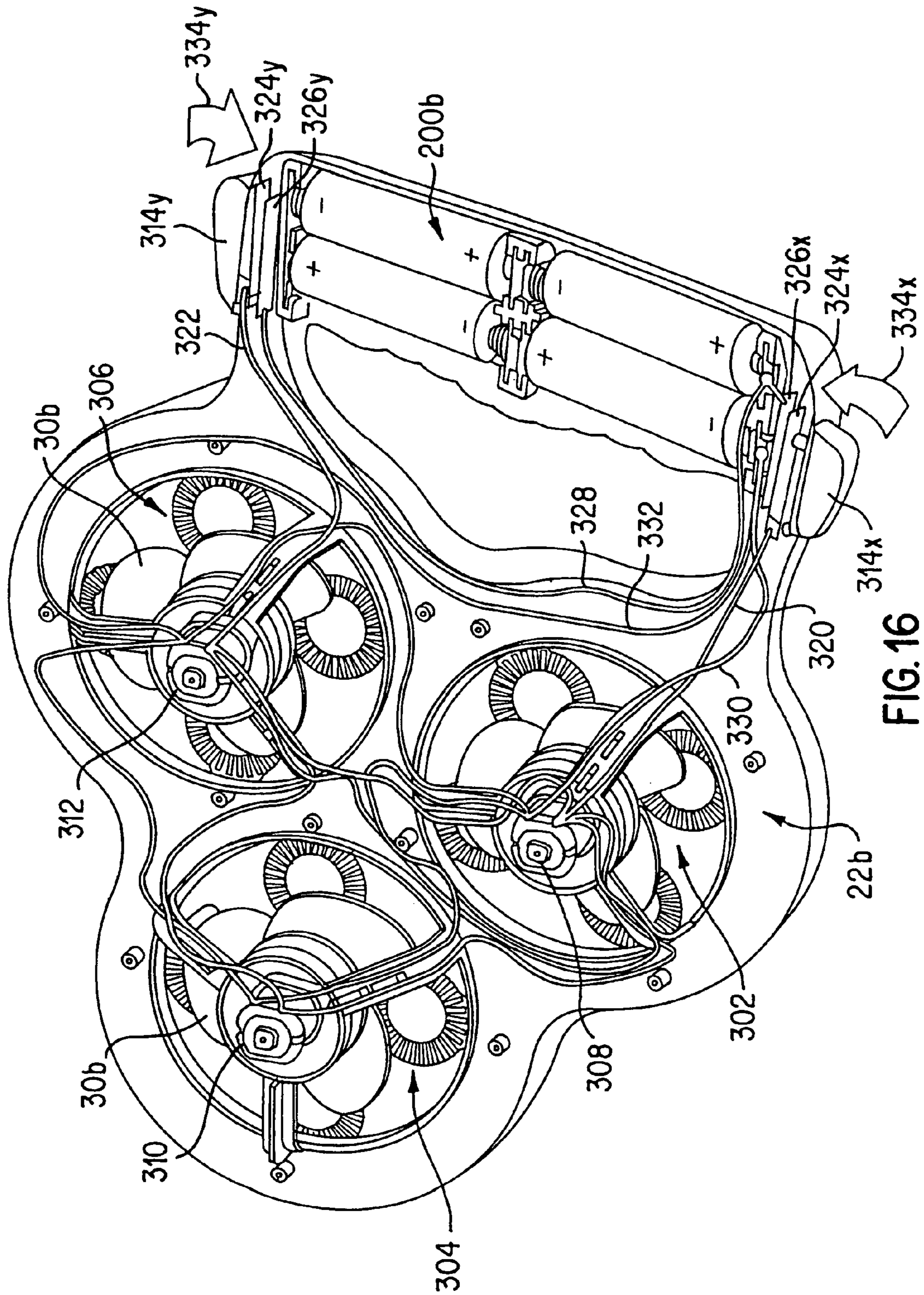

FIG. 16

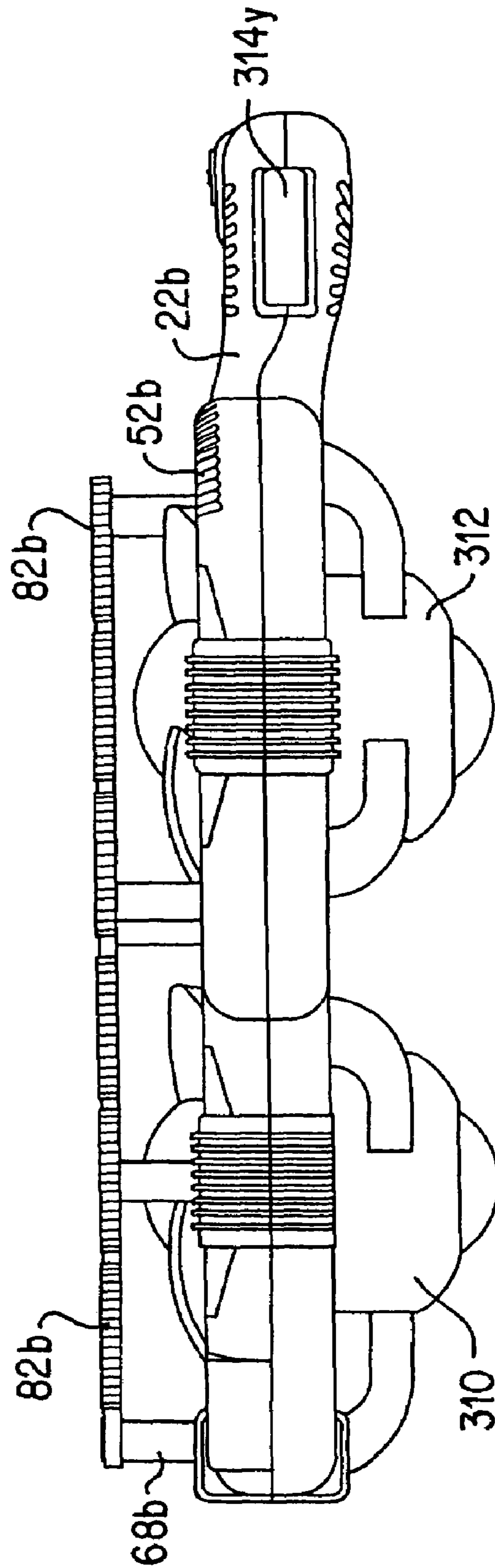

FIG.17

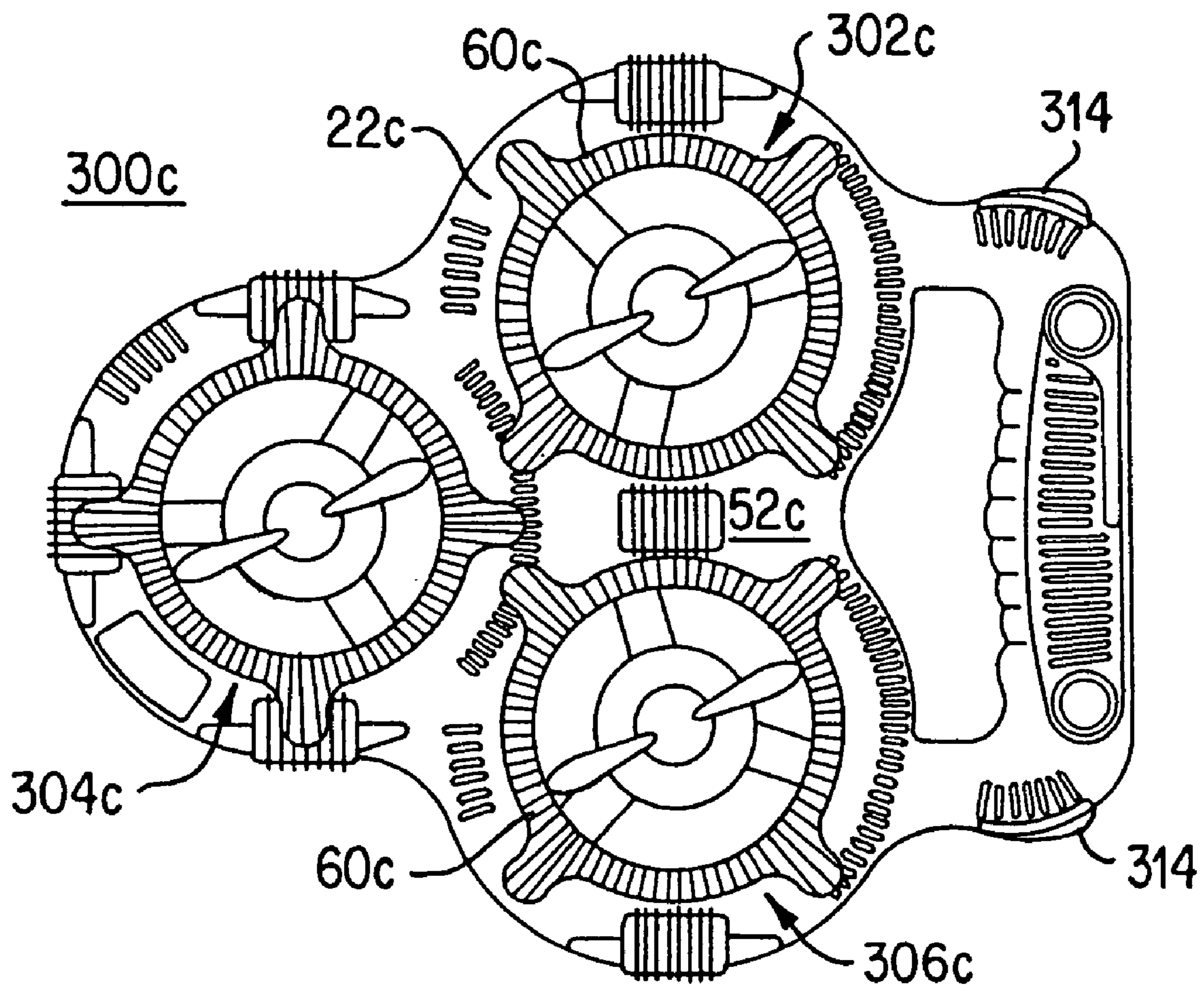

FIG. 18

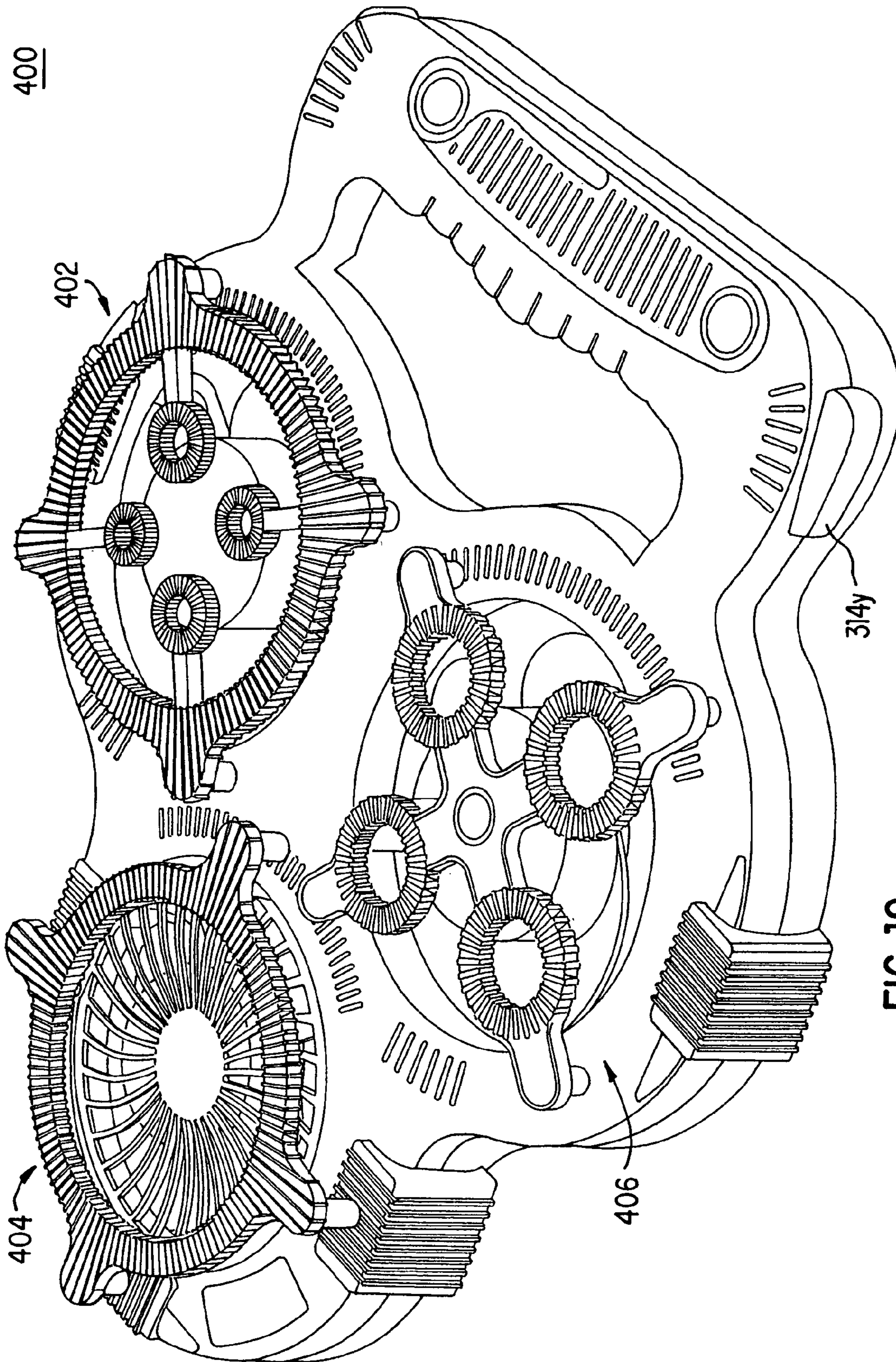

FIG. 19

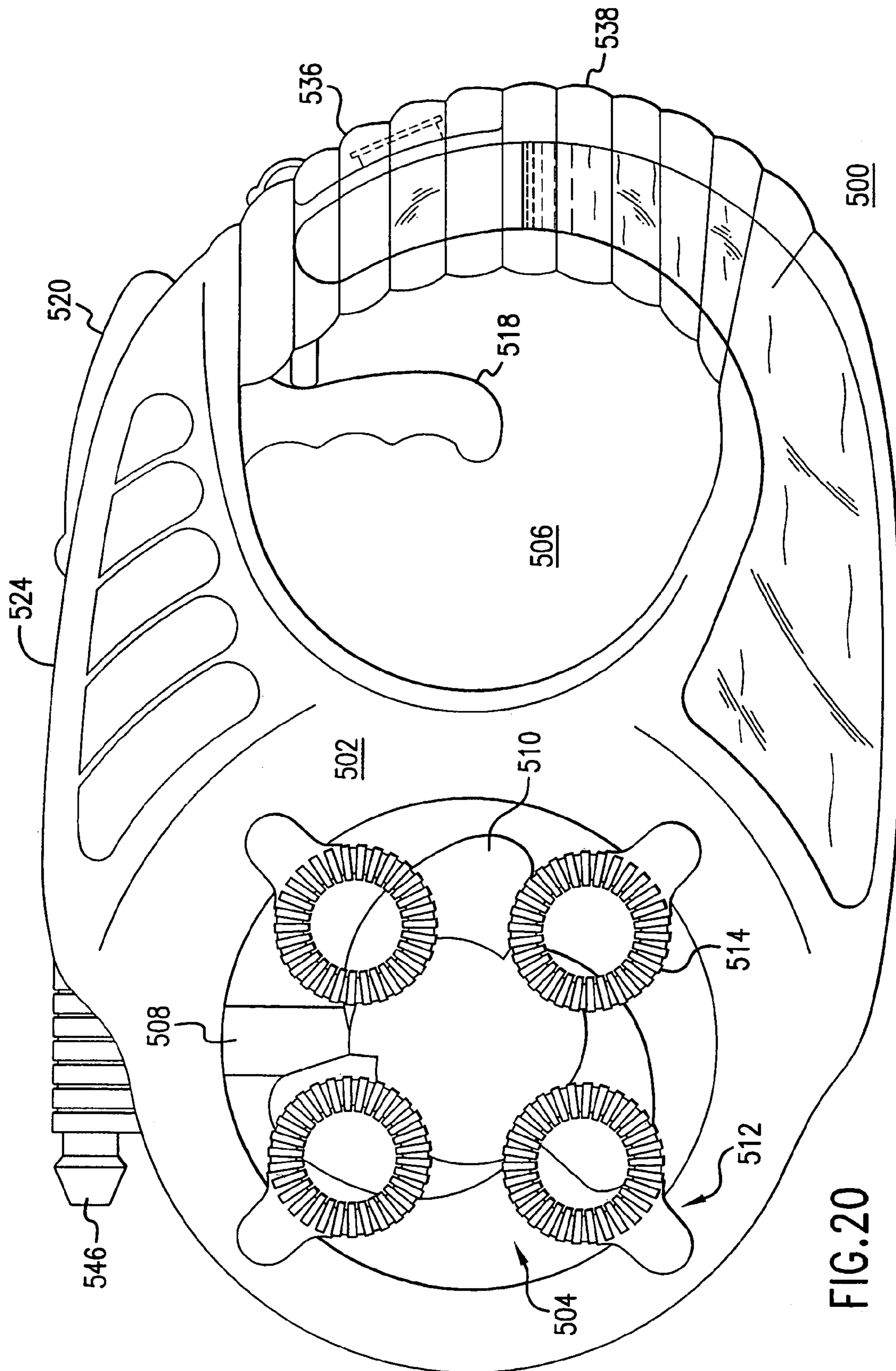

FIG. 20

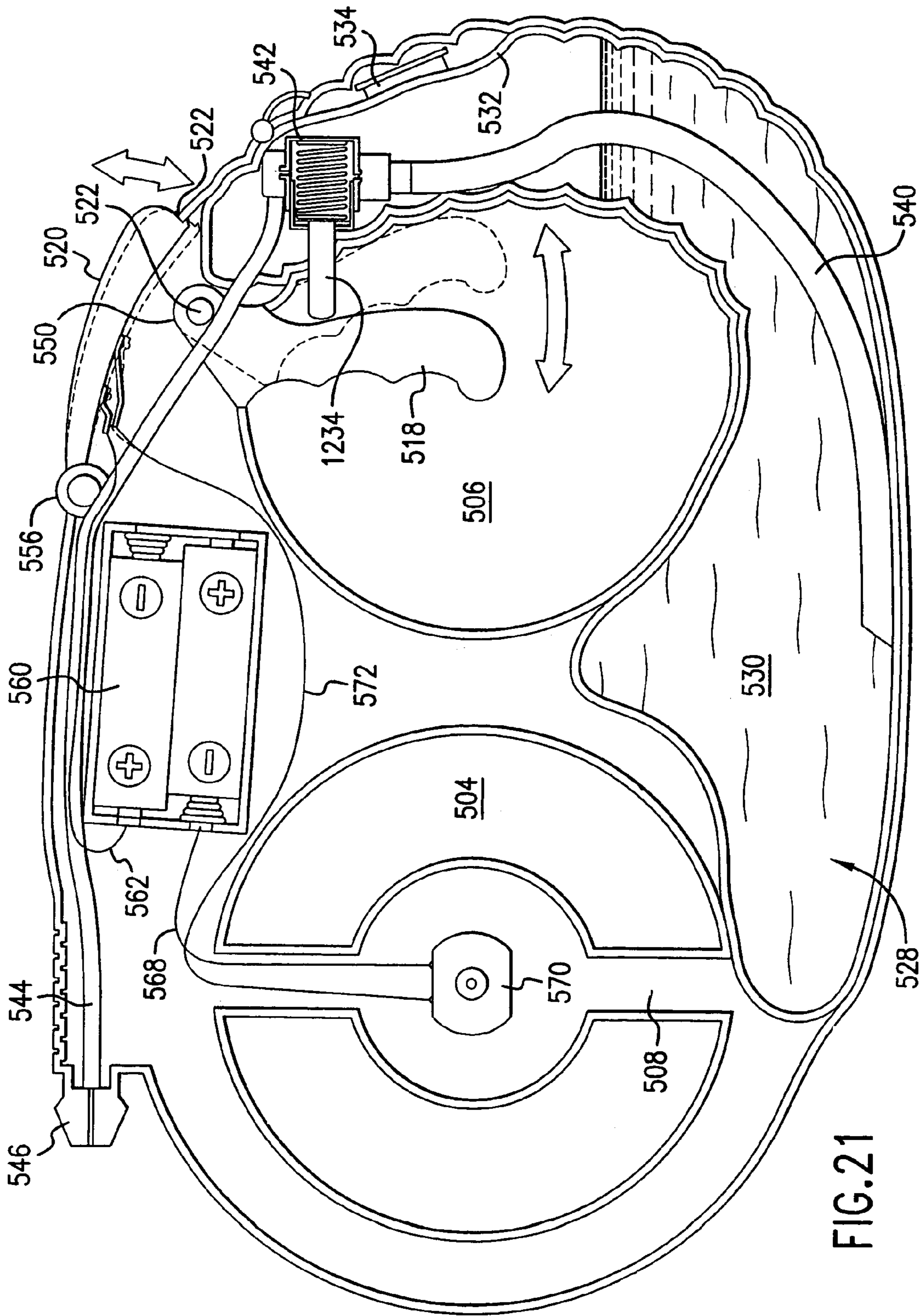
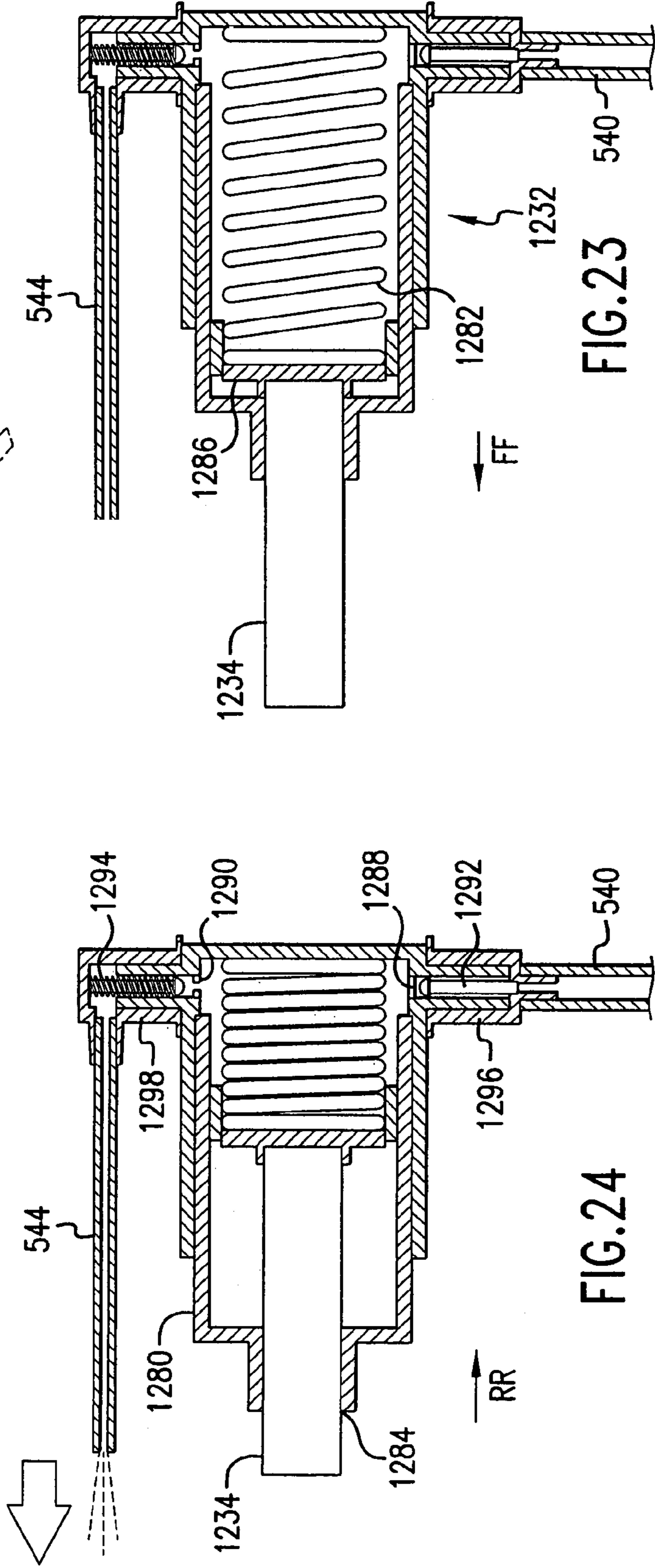
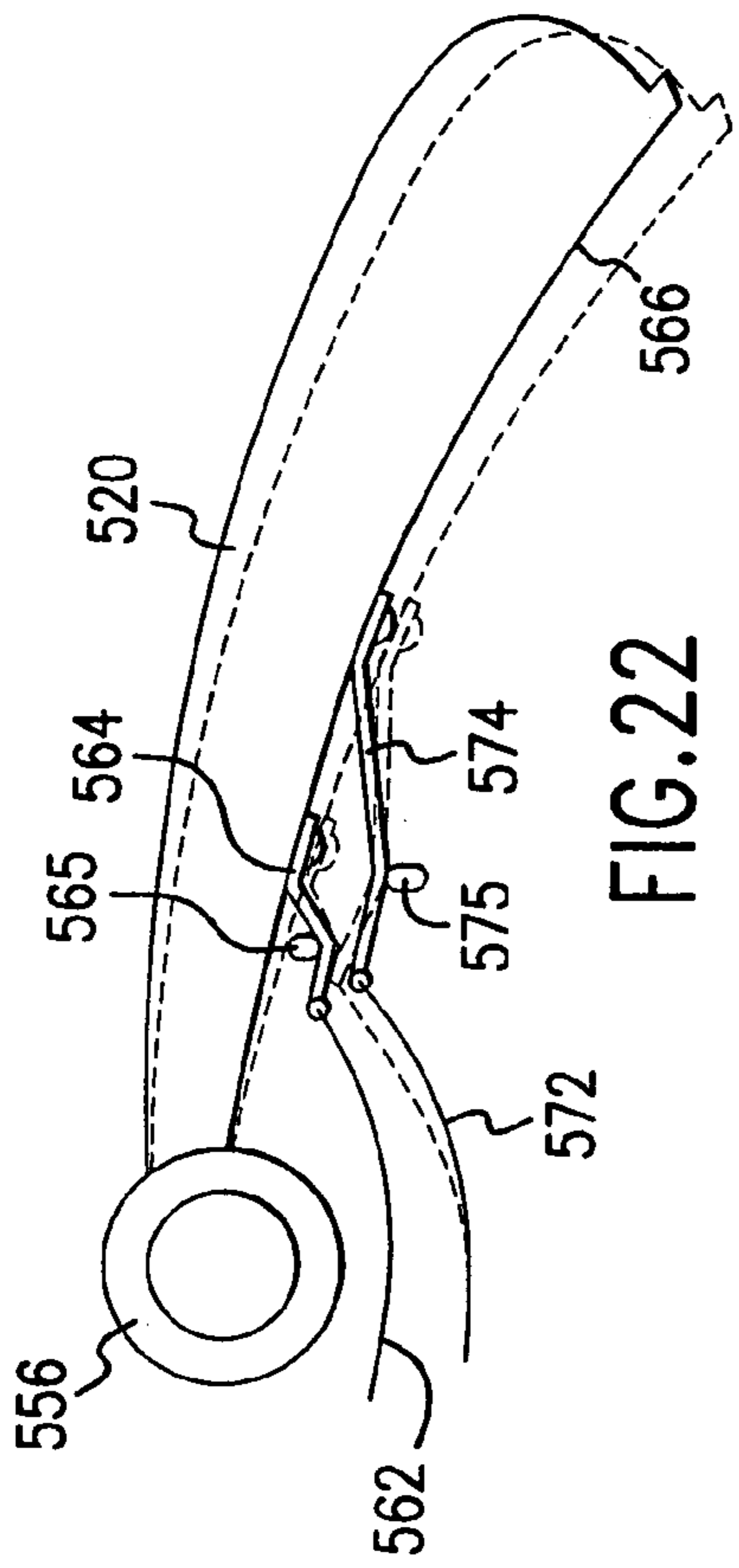

FIG. 21



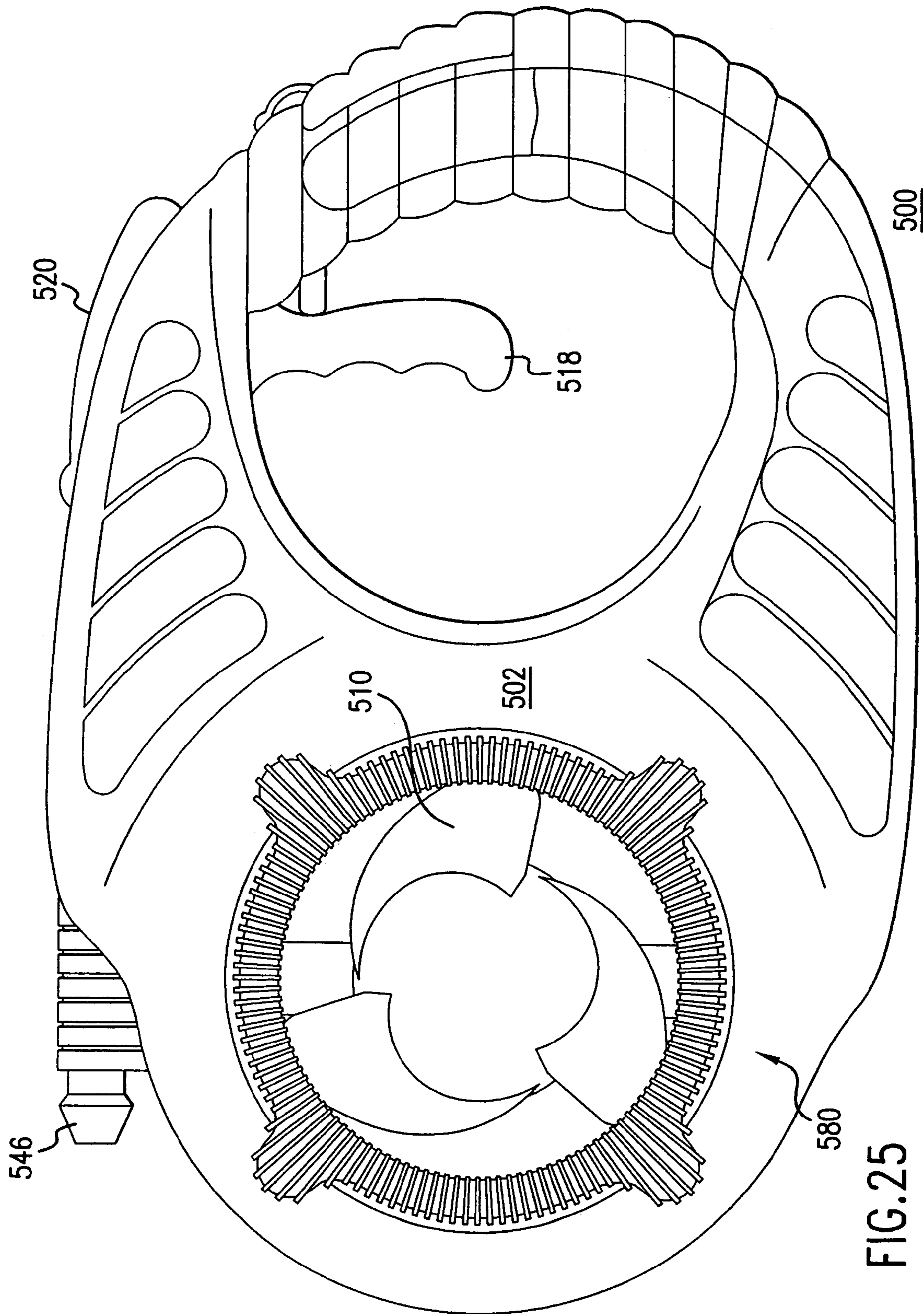

FIG. 25

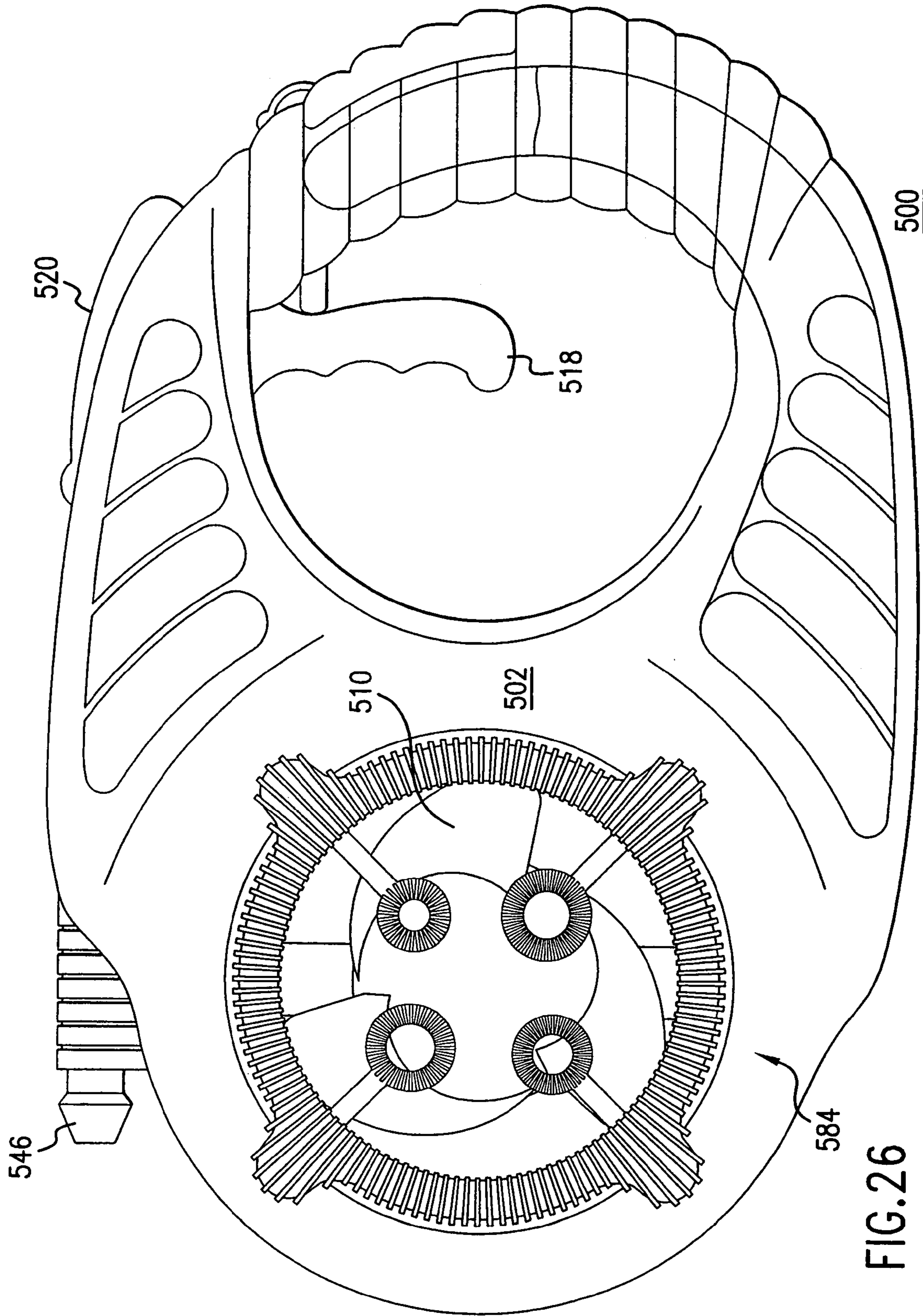

FIG. 26

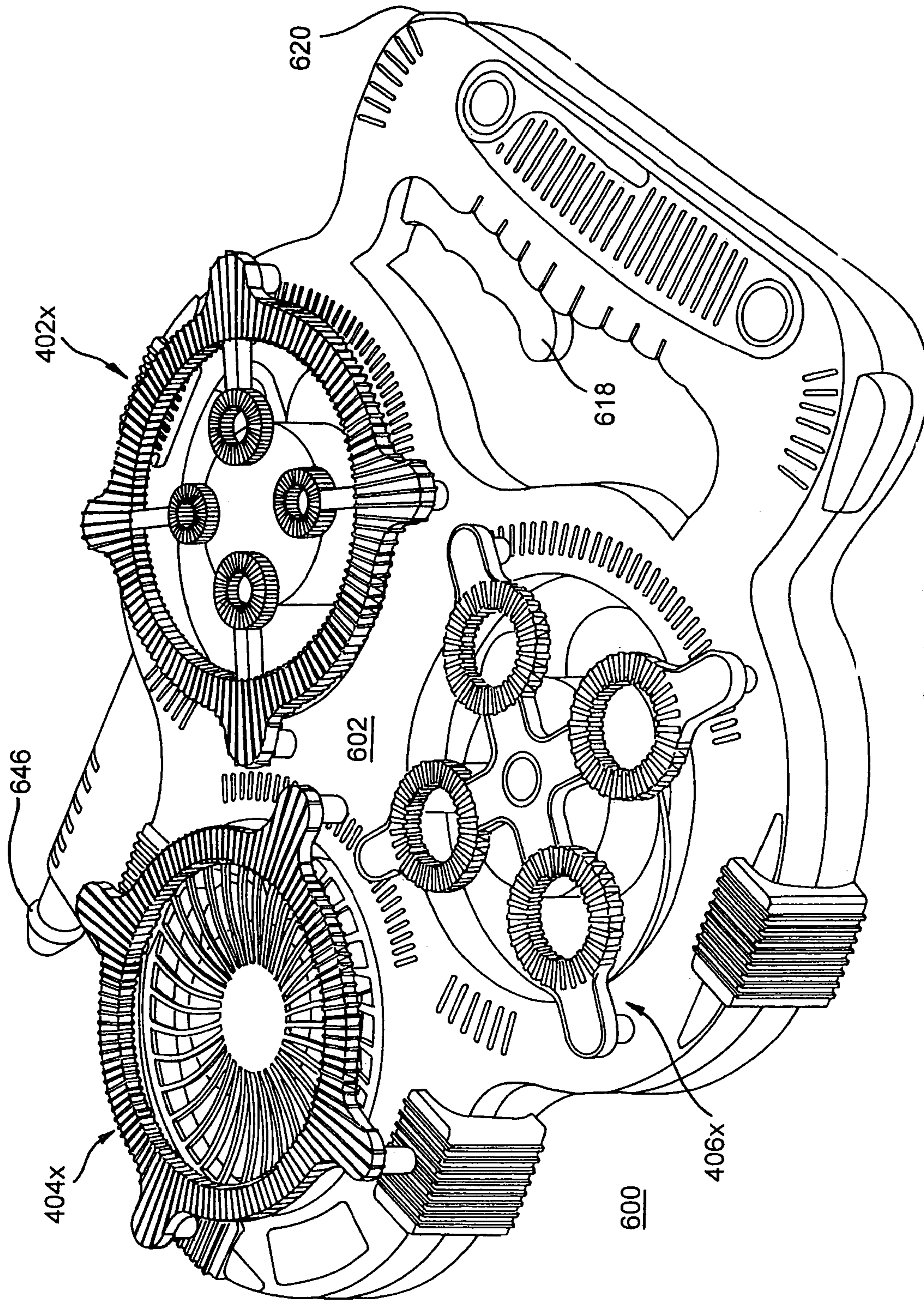

FIG. 27

BUBBLE GENERATING ASSEMBLY

RELATED CASES

This is a continuation of Ser. No. 10/072,196, filed Feb. 7, 2002 now U.S. Pat. No. 6,659,830, entitled "Bubble Generating Assembly", which is a divisional of Ser. No. 09/639,673, filed Aug. 15, 2000, entitled "Bubble Generating Assembly", now U.S. Pat. No. 6,544,091, which is a continuation-in-part of Ser. No. 09/551,814, entitled "Bubble Generating Assembly", filed Apr. 18, 2000, now U.S. Pat. No. 6,315,627, which is in turn a continuation-in-part of Ser. No. 09/347,973, entitled "Bubble Generating Assembly", filed Jul. 6, 1999, now U.S. Pat. No. 6,149,486, which is in turn a continuation-in-part of Ser. No. 09/277,512, entitled "Bubble Generating Assembly", filed Mar. 26, 1999, now U.S. Pat. No. 6,102,764, which is in turn a continuation-in-part of Ser. No. 09/207,542, entitled "Bubble Generating Assembly", filed Dec. 8, 1998, now U.S. Pat. No. 6,139,391, whose disclosures are incorporated by this reference as though fully set forth herein.

BACKGROUND OF THE INVENTION

1. Field of the Invention

The present invention relates to bubble-producing devices, and in particular, to a simple toy that is capable of producing bubbles within a larger enclosing bubble, and of simultaneously producing a plurality of separate bubbles.

2. Description of the Prior Art

Bubble producing toys are very popular among children who enjoy producing bubbles of different shapes and sizes. Many bubble producing toys have previously been provided. Perhaps the simplest example has a stick with a circular opening or port at one end, resembling a wand. A film is produced when the port is dipped into a bubble solution or bubble producing fluid (such as soap) and then removed therefrom. Bubbles are then formed by blowing carefully against the film. Such a toy requires dipping every time a bubble is to be created, and the bubble solution must accompany the wand from one location to another. Another drawback is that only one bubble can be produced at a time. Therefore, such simple bubble producing toys offer limited amusement and are limited in the types, shapes and sizes of the bubbles that they can produce.

As a result, attempts have been made to provide bubble producing toys that offer more variety and amusement. For example, U.S. Pat. No. 2,041,423 (Mausolf) discloses a soap bubble pipe that produces a cluster of three soap bubbles. U.S. Pat. No. 2,213,391 (Gamble) discloses a bubble blower that produces three bubbles, one bubble within the other. U.S. Pat. No. 4,467,552 (Jernigan) discloses a bubble within a larger exterior bubble.

Unfortunately, each of these devices has limited applications. For example, the device in U.S. Pat. No. 2,041,423 (Mausolf) can only produce a cluster of three bubbles. Also, the devices disclosed in U.S. Pat. No. 2,213,391 (Gamble) and U.S. Pat. No. 4,467,552 (Jernigan) can only produce one bubble within an outer bubble.

Another drawback associated with previously known or available bubble producing devices is that they do not always consistently produce complete bubbles. This problem is typically experienced by devices that attempt to produce more than one bubble, since the bubble solution may not adequately cover or coat all the surfaces of the loops and shapes that define these multiple bubbles.

Yet a further drawback associated with previously known or available bubble producing devices is that they often lack variety in play and amusement. These devices produce one or more bubbles that just merely float away.

Thus, there remains a need to provide devices that can produce different configurations and variations of bubbles so as to enhance the amusement value and play variety for children.

SUMMARY OF THE DISCLOSURE

It is an object of the present invention to provide a bubble producing device that produces a plurality of bubbles within an outer enclosing bubble.

It is another object of the present invention to provide a bubble producing device that produces a plurality of bubbles within an outer enclosing bubble that is in itself one of a plurality of bubbles that are enclosed within another larger outer enclosing bubble.

It is yet another object of the present invention to provide a bubble producing device that consistently produces complete bubbles.

It is a further object of the present invention to provide a bubble producing assembly that produces a plurality of separate bubbles upon the actuation of a single control mechanism.

It is a further object of the present invention to provide a bubble producing assembly that allows the user to shoot liquid at the produced bubbles.

The objectives of the present invention are accomplished by providing a bubble producing assembly that has a housing having an outlet, an air generator positioned on the housing, a bubble producing device positioned over the air generator, a first activator coupled to the air generator, a reservoir associated with the housing for storing a liquid, a pump system coupling the reservoir and the outlet, and a second activator coupled to the pump system for delivering the liquid from the reservoir out of the outlet. Thus, a user can use the first activator to generate air to produce bubbles, and can use the second activator to generate a stream of the liquid that can be aimed at the generated bubbles.

BRIEF DESCRIPTION OF THE DRAWINGS

FIG. 1 is a top perspective view of a bubble producing assembly according to one embodiment of the present invention.

FIG. 2 is a perspective view of the bubble producing device of the assembly of FIG. 1.

FIG. 3 is a side plan view of the bubble producing device of FIG. 2.

FIG. 4 is a top elevation view of the bubble producing device of FIG. 2.

FIG. 5 is a perspective view of a bubble solution dish that can be used with the bubble producing device of FIG. 2.

FIG. 6 is a top elevation view of the dish of FIG. 5.

FIG. 7 is a cross-sectional view of the dish of FIG. 6 taken along line 7—7 thereof.

FIGS. 8A–8C illustrate the operation of the assembly of FIG. 1.

FIG. 9 is a bottom perspective view of the assembly of FIG. 1.

FIGS. 10A and 10B illustrate how the lever of FIG. 1 operates to control the fan.

FIG. 11 illustrates how the fan of FIG. 1 is coupled to the motor.

3

FIG. 12 is a perspective view of a bubble producing device according to another embodiment which can be used with the assembly of FIG. 1.

FIG. 13 is a bottom perspective view of a bubble producing device according to yet another embodiment which can be used with the assembly of FIG. 1.

FIG. 14 is a side plan view of the bubble producing device of FIG. 13.

FIG. 15 is a top plan view of a bubble producing assembly according to yet another embodiment of the present invention.

FIG. 16 is a bottom plan view of the bubble producing assembly of FIG. 15.

FIG. 17 is a side plan view of the bubble producing assembly of FIG. 15.

FIG. 18 is a top plan view of a bubble producing assembly according to yet a further embodiment of the present invention.

FIG. 19 is a top perspective view of a bubble producing assembly according to yet another embodiment of the present invention.

FIG. 20 is a top plan view of a bubble producing assembly according to yet a further embodiment of the present invention.

FIG. 21 is a bottom cross-sectional view of the bubble producing assembly of FIG. 20.

FIG. 22 is a sectional view illustrating the operation of the push button of the assembly of FIG. 21.

FIG. 23 illustrates the trigger and pump of the bubble producing assembly of FIG. 21 in the non-use position.

FIG. 24 illustrates the trigger and pump of the bubble producing assembly of FIG. 21 in the bubble generating position.

FIGS. 25–27 illustrate the bubble producing assembly of FIGS. 20–22 in use with different bubble producing devices.

DETAILED DESCRIPTION OF THE PREFERRED EMBODIMENTS

The following detailed description is of the best presently contemplated modes of carrying out the invention. This description is not to be taken in a limiting sense, but is made merely for the purpose of illustrating general principles of embodiments of the invention. The scope of the invention is best defined by the appended claims. In certain instances, detailed descriptions of well-known devices and mechanisms are omitted so as to not obscure the description of the present invention with unnecessary detail.

The present invention provides a bubble producing device that produces multiple bubbles within an exterior enclosing bubble. The exterior enclosing bubble may itself be one of a multiple of other bubbles (each having one or more bubbles enclosed therewithin) that are in turn enclosed within a larger exterior enclosing bubble. The present invention accomplishes this by providing bubble producing openings or loops at different levels, or in other words, by layering these loops in a manner such that the plurality of loops at one level are vertically offset from the loops at other levels.

The present invention also provides a bubble producing device that produces a plurality of separate bubbles upon the actuation of a single control mechanism. This will be illustrated in connection with FIGS. 15–18.

FIG. 1 illustrates a bubble producing assembly 20 according to one embodiment of the present invention. The assembly has a frame 22 that includes a support section 24 and a handle section 26. The support section 24 is adapted to

4

receive a bubble producing device 28, as described below, and includes a fan 30 that is positioned below the bubble producing device 28 for generating air to produce bubbles. Specifically, the support section 24 has a central opening 32 extending through the frame 22 and into which a plurality of radial ribs 34 extend. The ribs 34 meet at a central point in the central opening 32 at which the fan 30 is supported. A plurality of openings 36 (shown in phantom) are provided along the edge 38 of the central opening 32 for receiving protrusions of the bubble producing device 28, as explained below.

The handle section 26 has an elongated opening 46 adjacent an end 48 of the frame 22 for allowing a user's fingers to be inserted therethrough. The edges of the elongated opening 46 can be serrated or curved to receive the respective fingers of a user's hand. Thus, a user can insert his or her fingers through the elongated opening 46 to grip the frame 22 and the assembly 20. In addition, a lever mechanism 50 is provided at the top surface 52 of the frame 22 adjacent a side edge 54 of the frame 22 to allow the user to control the speed of rotation of the fan 30. The lever mechanism 50 is illustrated as being provided adjacent one side edge 54 of the frame 22 and between the handle section 26 and the support section 24 in the present embodiment, although it can be positioned anywhere in the assembly 20 as long as it can be conveniently coupled to the fan 30 to drive the fan 30.

FIGS. 9–11 illustrate how the lever mechanism 50 controls the rotation of the fan 30. FIG. 9 is a bottom perspective view of the assembly 20 with the bottom surface of the frame 22 removed. First, the handle section 26 houses a battery system 200 having a plurality of batteries. A first wire 202 couples the contacts of the battery system 200 to the lever mechanism 50, while a second wire 204 couples the contacts of the battery system 200 to a motor 206 to power the motor 206. A third wire 208 couples the lever mechanism 50 to the motor 206 to drive the motor 206. The second and third wires 204 and 208 are supported underneath the frame 22 and the ribs 34. Referring to FIG. 11, the motor 206 has a rotatable shaft 210 that is received inside a bore 212 in the fan 30 to rotate the fan 30.

The lever mechanism 50 is illustrated in greater detail in FIGS. 10A and 10B. FIG. 10A is an expanded view of the lever mechanism 50 as taken from FIG. 9, with a portion of the lever plate 222 shown in phantom. FIG. 10B is a view of the underside (i.e., opposite to that shown in FIG. 10A) of the lever mechanism 50 as seen from the top surface 52 of the frame 22. The lever mechanism has a lever arm 220 coupled to a plate 222 (see FIGS. 9 and 10B, and shown in phantom in FIG. 10A) that extends through an opening (not shown) in the side edge 54 of the frame 22. An electrical conductor (i.e., contacts) 224 is provided on the underside of the plate 222 and adapted to contact or couple to one of a plurality of conductors 226 provided on the underside of the top surface 52 of the frame 22. Each of the plurality of conductors 226 is adapted to control rotation of the fan 30 at a different speed, as explained below. A screw 228 extends through a screw hole 230 in the plate 222 to secure the plate 222 in a pivotable connection with the frame 22. The lever mechanism 50 also includes a spring 232 that is supported by the screw 228 between the plate 222 and the frame 22. The spring 232 operates to normally bias the plate 222 back to the "OFF" position shown in FIG. 9. Two stop edges 236, 238 define the limits to which the lever plate 222 can be pivoted.

In operation, the lever mechanism 50 is shown in FIG. 9 in the "OFF" position adjacent the stop edge 238, where the

fan 30 is not rotated. If it is desired to rotate the fan 30, the user pivots the lever arm 220 in the direction of arrow 234 to cause the lever conductor 224 to contact a first of the conductors 226, thereby causing the fan 30 to rotate at a first speed. Turning the lever arm 220 further in the direction of arrow 234 will cause the lever conductor 224 to contact a second of the conductors 226, thereby causing the fan 30 to rotate at a second faster speed, and so on. When the user releases the lever arm 220, the spring 232 will bias the plate 222 and lever 220 back to the "OFF" position.

Although the present invention is illustrated as utilizing a motor that is integral with the assembly 20 to drive the fan 30, it is also possible to utilize the assembly 20 with other air generation devices (e.g., blowing by mouth, or a separate fan) without the use of an integral motorized fan. The bubble producing device 28 is illustrated in greater detail in FIGS. 2-4. The bubble producing device 28 is essentially a ring-like loop having a primary serrated ring 60, such that ridges or bumps 62 are provided on the outer surfaces of the primary ring 60. The ridges 62 function to hold the bubble solution against the ring 60 to form a solution film that is blown to form the bubble. The ring 60 can have any desired shape. A plurality of extensions or flanges 64 extend from the outer periphery 66 of the primary ring 60. These flanges 64 can be spaced-apart in an equi-distant manner from each other, or provided at any desired spacing. In addition, any number (i.e., two or more) of the flanges 64 and their corresponding legs and secondary rings can be chosen by the designer. A leg 68 extends vertically from the bottom surface 70 of each flange 64. Each leg 68 has a thin upper portion 72 extending from the bottom surface 70 to a tapered portion 74 that resembles a truncated cone. The narrower end of the tapered portion 74 connects the bottom end of the upper portion 72, and the wider end of the tapered portion 74 connects the top end of a wide base portion 76. A vertical protrusion 78 extends vertically from the bottom end of the base portion 76, and is adapted to be inserted into a corresponding one of the openings 36 that are provided along the edge 38 of the central opening 32. In addition, a tongue 80 has a first end connected to the leg 68 adjacent the connection between the upper portion 72 and the tapered portion 74, and a second end that extends radially into the interior of the primary ring 60 and connects and supports a secondary ring 82. The secondary ring 82 can have any desired shape, such as the shape of the primary ring 60 or any other shape, but it is preferably smaller than the primary ring 60. The secondary rings 82 can also have ridges 62, like the primary ring 60. Also, as best illustrated in FIGS. 2 and 3, the secondary ring 82 is vertically offset from the primary ring 60 by a distance d (measured from the middle of the rings 60 and 82) by virtue of the connection of the tongue 80 to the leg 68 at a vertical level below the leg's 68 connection to the flange 64 of the primary ring 60. In addition, the tongue 80 and its secondary ring 82 can be disposed generally parallel to the planar orientation of the primary ring 60. All the legs 68, tongues 80 and secondary rings 82 of the flanges 64 can be of the same construction, although the shapes and sizes of the secondary rings 82 can be different. For example, in FIG. 4, one secondary ring 821 is smaller than the other secondary rings 82, and operates to produce smaller bubbles.

Each of the primary ring 60 and secondary rings 82 are provided to create a separate bubble. The secondary rings 82 are provided at a vertical level offset from the primary ring 60 so as to allow a plurality of smaller bubbles to be produced. The inventor has found that if the secondary rings 82 are positioned at the same vertical level as the primary

ring 60, the result may be that only one large bubble (i.e., emanating from the primary ring 60) is produced or a plurality of irregular bubbles (i.e., emanating from the internal spaces between the primary ring 60 and the secondary rings 82) are produced without an enclosing larger bubble. In addition, the secondary rings 82 are smaller in size than the primary ring 60 to ensure that the resultant bubbles are smaller and sized to fit inside the larger enclosing bubble produced by the primary ring 60.

FIGS. 5-7 illustrate a bubble solution dish 100 that can be used with the bubble producing device 28 of FIGS. 2-4. The dish 100 has a base plate 102 and a shallow outer enclosing wall 104 extending around the base plate 102. An inner enclosing wall 106 defines an annular outer space or compartment 108 between the inner wall 106 and the outer wall 104. In addition, a generally circular inner space or compartment 110 is defined by the inner surface 112 of the inner wall 106. The inner space 110 has an inner plate 114 that is at a higher vertical level than the base plate 102. The shapes and sizes of the inner and outer walls 106 and 104, respectively, are dependent on the shape, size and positions of the primary ring 60 and the secondary rings 82. These spaces 108, 110 are vertically offset from each other because the outer space 108 is adapted to receive the primary ring 60 and the inner space 110 is adapted to receive the secondary rings 82. In addition, the dish 100 has a generally circular configuration because the primary ring 60 is generally circular. Moreover, a sharp spout 116 is provided at one location on the outer wall 104, and angles from the base plate 102 to the top of the outer wall 104. The spout 116 assists the user in pouring leftover bubble solution from the dish 100 back into the original bubble solution container.

The operation of the assembly 20 is illustrated in connection with FIGS. 8A-8C. First, the bubble producing device 28 is dipped into the dish 100, which holds bubble solution in both its spaces 108, 110. Any conventional bubble solution can be used. The primary ring 60 is received inside the outer space 108 and can be rested therein until the primary ring 60 contacts the base plate 102. When the primary ring 60 contacts the base plate 102, the secondary rings 82 will be received inside the inner space 110 and may possibly contact the inner plate 114. The bubble producing device 28 is then removed from the dish 100 and the protrusions 78 of the legs 68 inserted into the openings 36 to secure the bubble producing device 28 on the frame 22 of the assembly 20.

Alternatively, the bubble producing device 28 can first be secured on to the frame 22 of the assembly 20 before dipping into the dish 100.

With bubble solution now extending in the form of a film across the openings of the rings 60 and 82, the user actuates the fan 30 by turning the lever arm 220. The speed of rotation of the fan 30 is controlled by turning the lever arm 220 in the direction of arrow 234. The further lever arm 220 is pivoted away from the "OFF" position (i.e., adjacent stop edge 238), the faster the fan 30 will rotate. Initially, the user rotates the fan 30 at a lower speed to cause only the primary ring 60 to partially produce a large enclosing bubble 130 (see FIG. 8A). The low speed of the fan 30 means that the smaller bubbles of the secondary rings 82 are not produced, because there is a lesser quantity of bubble solution extending across the openings of the smaller secondary rings 82 which does not react as easily with the wind source. As the larger bubble 130 is being created, the user accelerates the rotation of the fan 30 to create a plurality of smaller bubbles 132 from the four secondary rings 82 (see FIG. 8B). Depending on the amount of bubble solution remaining on

the secondary rings **82**, each secondary ring **82** can produce more than one smaller bubble **132**. The accelerated rotation of the fan **30** causes the larger bubble **130** to enlarge or grow in size. Continued rotation of the fan **30** will complete the creation of the larger bubble **130** so that it completely encloses the smaller bubbles **132** (see FIG. **8C**). Accelerated rotation of the fan **30** will also push the completed larger bubble **130** out of the primary ring **60**.

Instead of providing the complete assembly **20** as illustrated in FIG. **1A**, it is also possible for the user to use the bubble producing device **28** alone to produce bubbles. For example, if the sizes of the rings **60** and **82** are sufficiently small, a shaft or wand can be attached to the primary ring **60**, so that the user can grip the shaft, dip the bubble producing device **28** into the dish **100**, and then blow air at the rings **60** and **82** to produce the bubbles **130**, **132**, varying the blowing force to create the larger bubble **130** before the smaller bubbles **132**. Alternatively, the user can grip the shaft that connects the bubble producing device **28** and place it in front of (i.e., in the path of) a separate fan unit to create the desired bubbles **130**, **132**. Thus, the bubble producing device **28** can be utilized without the fan **30** of the assembly **20**.

Although FIGS. **1–8** illustrate a bubble producing device **28** as having two levels of rings, so that a plurality of smaller bubbles **132** are produced inside a larger enclosing bubble **130**, this is merely illustrative of the basic principles of the present invention. It is also possible to provide more than two levels of rings to create even smaller bubbles within each small bubble **132**. For example, FIG. **12** illustrates a bubble producing device **150** having a large primary ring **160** (just like primary ring **60**), a second layer of intermediate rings **162**, **164**, **166**, **168**, and a third layer of smaller rings **170**. The intermediate rings **162** and **164** in the second layer are smaller than the intermediate rings **166** and **168**, and do not have any other rings provided therewithin. However, intermediate rings **166**, **168** each has two smaller rings **170** provided therewithin. The three layers of rings are at different vertical levels, and each layer can be supported from a different vertical point in each leg **172** of the bubble producing device **150**.

FIGS. **13** and **14** illustrate a modification that can be made to the bubble producing device **24** of FIGS. **2** and **3**. The bubble producing device **28a** of FIGS. **13** and **14** is the same as bubble producing device **28** of FIGS. **2** and **3** except for the provision of cylindrical walls **83** provided for each secondary ring **82a**, so the same numeral designations are used except that an “a” has been added to the designations in FIGS. **13** and **14**. As shown in FIGS. **13** and **14**, each secondary ring **82a** has a cylindrical wall **83** extending vertically downwardly from the ring **82a** to form a tube-like-extension. As shown in FIG. **13**, the wall **83** can extend from the outer periphery of its corresponding ring **82a**, so that the ridges **62a** of the secondary rings **82a** are disposed inside the wall **83** to further facilitate holding the bubble solution against the ring **82a** to form a solution film that is blown to form the bubble. Each wall **83** defines a channel **85** that allows air generated from the bottom of the bubble producing device **28a** (see direction of arrow **87**) to enter each channel **85** from the bottom edge **89** of the corresponding wall **83**. Each channel **85** functions to direct a collected mass of air towards its corresponding secondary ring **82a**, to further facilitate the generation of a full and complete bubble by the secondary ring **82a**.

To further enhance the quality of the bubble produced by the secondary rings **82a**, each wall **83** is angled. In other words, each wall **83** can be configured so that it has a varying length (as measured from the secondary ring **82a**)

around its circumference. For example, referring to FIG. **14**, the bottom edge **89** of each wall **83** can be cut at an angle with respect to the horizontal axis defined by the primary ring **60a**. The angled configuration of the walls **83** shown in FIGS. **13** and **14** efficiently captures the spiraling air that is created by a rotating fan **30**. Each angled cylindrical wall **83** traps the air and concentrates the trapped air mass to direct them through the secondary rings **82a**. This increases the amount of air that actually passes through the corresponding secondary ring **82a**, and minimizes air that passes around the-secondary ring **82a**. As a result, better and more consistent streams of smaller bubbles can be created by the secondary rings **82a**.

In addition, the quality of the bubble produced by the secondary rings **82a** can-be even further enhanced by increasing the length of the walls **83**. This is because a longer cylindrical wall **83** has an increased inner volume (i.e., a greater volume in the channel **85**) so that more air can be trapped and concentrated. However, if the length of the walls **83** is increased, greater air flow must be provided because the air that is trapped inside the respective channels **85** must travel a greater distance to reach the secondary rings **82a**.

The method of operation for the bubble producing device **28a** of FIGS. **13** and **14** can be the same as that described above in connection with FIGS. **8A–8C**, except that the generated air is trapped by the walls **83** and directed to the secondary rings **82a** by the force created by the additional air being generated behind it.

The walls **83** can be provided for any of the secondary rings, including the rings **162**, **164**, **166**, **168** and **170** shown in FIG. **12**.

Thus, the bubble producing devices described herein-above are easy to use, and consistently provide multiple bubbles inside larger enclosing bubbles, thereby increasing the amusement value and play variety for the user. The provision of the bubble-producing rings **60**, **82**, **82a** at separate, spaced-apart and offset levels ensure that the differently-sized bubbles **130**, **132** are produced in a consistent and effective manner.

Referring now to FIGS. **15–17**, the present invention also provides a bubble producing assembly **300** that produces a plurality of separate bubbles upon the actuation of a single control mechanism. Bubble producing assembly **300** is essentially the same as bubble producing assembly **20** of FIG. **1** except for the differences noted hereinbelow. Therefore, the same numeral designations are used in FIGS. **1–4** and **15–17** where possible except that a “b” has been added to the designations in FIGS. **15–17**.

The bubble producing assembly **300** differs primarily from the bubble producing assembly **20** of FIG. **1** in that it provides three separate bubble producing devices **302**, **304**, **306**, instead of the one bubble producing device **28** for assembly **20**. In addition, the lever mechanism **50** in assembly **20** is replaced by a control mechanism **314** that can simultaneously actuate all three bubble producing devices **302**, **304**, **306**. Each bubble producing device **302**, **304**, **306** can have the same or a similar configuration, and each is controlled or driven by a separate motor **308**, **310**, **312**, respectively. As shown in FIG. **16**, the control mechanism **314** can comprise two switches **314x** and **314y** that control the operation of the motors **308**, **310**, **312**, although one switch **314x** or **314y** alone is sufficient to control the operation of the motors **308**, **310**, **312**. Each switch **314x** and **314y** is fitted through an opening in the frame **22b** and has a contact plate **324x** and **324y**, respectively. Each contact plate **324x** and **324y** is wired to at least one of the three

motors **308**, **310** or **312** (e.g., see wires **320** and **322** that couple the plates **324x** and **324y**, respectively, to motors **302** and **306**, respectively), and each motor **308**, **310**, **312** is further wired to the other two motors, so that all three motors **308**, **310**, **312** can be simultaneously driven when either or both switches **314x** and **314y** is actuated. In addition, terminal plates **326x** and **326y** are provided at the opposing terminals of the battery system **200b**, with the terminal plates **326x** and **326y** coupled by a wire **328**, and with additional wires **330** and **332** coupling the terminal plate **326x** with the motors **302** and **306**, respectively.

All the motors **302**, **304**, **306** are simultaneously actuated (i.e., driven) when either switch **314x** or **314y** is pressed in the direction of arrow **334x** or **334y**, respectively, which causes the contact plate **324x** or **324y** to contact the corresponding terminal plate **326x** or **326y**, respectively. Alternatively, both switches **314x** and **314y** can be pressed at or about the same time to actuate all the motors **302**, **304**, **306**.

Another difference between the bubble producing assembly **300** and the bubble producing assembly **20** of FIG. 1 lie in the structure of the bubble producing devices **302**, **304**, **306** and **28**. While the bubble producing device **28** has one primary ring **60** and a plurality of secondary rings **82** positioned in an offset manner, each bubble producing device **302**, **304**, **306** has no primary ring **60**, but has a plurality of spaced-apart rings **82b** that are the same in construction as the secondary rings **82** shown in FIGS. 1–4. As shown in greater detail in FIGS. 15 and 17, each ring **82b** extends radially inwardly into the opening **32b** from a leg **68b** that extends vertically from the top surface **52b** of the frame **22b**. Although FIG. 15 illustrates that each bubble producing device **302**, **304**, **306** has four rings **82b**, any number of rings **82b** can be provided for each bubble producing device **302**, **304**, **306**. In addition, even though all the rings **82b** are illustrated as being positioned at the same vertical level, it is also possible to offset some of the rings **82b** with respect to other rings **82b** of the same or other bubble producing devices.

FIG. 18 illustrates a bubble producing assembly **300c** that includes a modification made to the bubble producing assembly **300**. The assemblies **300** and **300c** are the same, except that each bubble producing device **302c**, **304c**, **306c** in FIG. 18 has one ring **60c**, which can have the same construction as the primary rings **60** in FIGS. 1–4, and has no secondary rings **82** or **82b**. Therefore, the same numeral designations are used in FIGS. 15–17 and 18 where possible except that a “c” has been added to the designations in FIG. 18. Each ring **60c** can be supported by a plurality of legs (not shown) that extend vertically from the top surface **52c** of the frame **22c**.

The method of operation for the bubble producing assemblies **300** and **300c** of FIGS. 15–18 can be the same as that described above in connection with FIGS. 8A–8C, except that the assembly **300** will produce a plurality of separate bubbles, and the assembly **300c** will produce fewer but larger bubbles than the assembly **300**. The bubbles produced by the assembly **300c** are also separated. Thus, neither assembly **300** or **300c** will produce a plurality of bubbles within an enclosing larger bubble. However, it will also be appreciated by those skilled in the art that the bubble producing devices **28** and **28a** can also be used with the assemblies **300** and **300c** to provide a plurality of larger enclosing bubbles that each contain a plurality of bubbles therein.

Although FIGS. 15–18 illustrate bubble producing assemblies **300** and **300c** that have a certain number of motors, bubble producing devices and rings, it is also possible to

provide any number of motors, bubble producing devices and rings as desired to make up a bubble producing assembly.

In addition, all the principles illustrated in FIGS. 1–11 and 15–18 above can be combined, as embodied by the bubble producing assembly **400** in FIG. 19. The bubble producing assembly **400** utilizes the same housing, motors **308**, **310**, **312**, and switches **314x**, **314y** as for assembly **300** in FIG. 16. In fact the bottom view of the assembly **400** can be the same as that which is shown in FIG. 16. The primary difference between the assemblies **300** and **400** is that while the three bubble producing devices **302**, **304**, **306** in assembly **300** can be the same, the three bubble producing devices **402**, **404**, **406** in assembly **400** can be entirely different from each other. For example, the bubble producing device **402** can be the same as the bubble producing device **28**, which has one primary ring **60** and a plurality of secondary rings **82** that are positioned in an offset manner. The bubble producing device **406** can be the same as the bubble producing device **302**, which has a plurality of spaced-apart rings **82b** that are the same in construction as the secondary rings **82** shown in FIGS. 1–4. In addition, the bubble producing device **404** can be the same as bubble producing device **302c** in FIG. 18, which has one ring **60c** and can have the same construction as the primary rings **60** in FIGS. 1–4, and which has no secondary rings **82** or **82b**.

Thus, the bubble producing assembly **400** in FIG. 19 can be operated in the same manner as the assemblies **300** and **300c** in FIGS. 15–18, except that the assembly **400** would simultaneously produce three different types of bubbles. Specifically, the bubble producing device **402** would produce a plurality of smaller bubbles within a larger bubble, the bubble producing device **406** would produce a plurality of separate bubbles, and the bubble producing device **404** will produce single large bubbles without any bubbles retained inside. Thus, the assembly **400** would simultaneously produce three different types of bubbles. These different types of bubbles provide the user with enhanced play variety and amusement.

The bubble producing devices that have been described hereinabove can be utilized with other different types of bubble producing assemblies. FIGS. 20–22 illustrate a bubble producing assembly **500** which allows the user to shoot a stream of liquid at the produced bubbles. The assembly **500** has a housing **502** that defines a first opening **504** and a second opening **506**, both of which can extend through the housing **502**. The second opening **506** functions as a handle opening for grip by a user’s fingers. A pair of radial ribs **508** extend into the first opening **504**, and meet at a central point in the first opening **504** at which a fan **510** is supported. A bubble producing device **512** is positioned over the first opening **504** and the fan **510**. The bubble producing device **512** is illustrated as having the same structure as the bubble producing device **302** of FIG. 15, having four spaced-apart rings **514** that are the same as the rings **82b** in FIG. 15 to produce a plurality of separate bubbles.

Two activating mechanisms are provided for the assembly **500**. A pivotable trigger **518** is positioned inside the second opening **506**. In addition, a push button **520** extends from an opening **522** positioned along the top wall **524** of the housing **502**. The push button **520** is pivotably secured to the housing **502** via a shaft or pin **556**.

Inside the housing **502**, a reservoir **528** is positioned adjacent the second opening **506** and is adapted to hold a liquid **530**, such as water. The reservoir **528** has an opening **532** that is normally sealed by a plug **534**. The plug **534** and opening **532** are positioned adjacent a pivoting cap **536** that

is positioned along the rear wall **538** of the housing **502**. Thus, liquid **530** can be introduced into or removed from the reservoir **528** via the cap **536** and the plug **534**. A first tubing **540** has one end that extends into the reservoir **528** and an opposite end that is coupled to a pump **542**. A second tubing **544** has one end that is also coupled to the pump **542**, and extends through the interior of the housing **502** along the top wall **524** to an opposite end that is secured to a nozzle **546**. The inner end **550** of the trigger **518** is secured for pivoting movement about a shaft or pin **552** that is held inside the housing **502**. A piston **1234** of the pump **542** is coupled to the trigger **518**. The operation of the pump **542** and its piston **1234** will be explained in greater detail below in connection with FIGS. **23** and **24**.

The housing **502** houses a power source **560** which can include two conventional batteries. Referring to FIGS. **21** and **22**, a first wire **562** couples the contacts of the power source **560** to a first contact **564** that is attached to the bottom surface **566** of the push button **520**. The first contact **564** has an inverted Z-shape with two bends, and one of its bends pivots about a pivot **565** that is secured to the housing **502**. A second wire **568** couples the contacts of the power source **560** to a motor **570** that is coupled to the fan **510**. A third wire **572** couples the motor **570** to a second contact **574** that is also attached to the bottom surface **566** of the push button **520**, and spaced-apart from the first contact **564**. The second contact **574** also has an inverted Z-shape with two bends, and one of its bends pivots about another pivot **575** that is secured to the housing **502**. The two contacts **564** and **574** are springy in nature, and function to normally bias the push button **520** away from the top wall **524** as shown in FIGS. **21** and **22**. In this normal biased position, the two contacts **564** and **574** are separated from each other, thereby forming an open circuit.

Referring now to FIGS. **23** and **24**, the pump **542** has a pump chamber **1280** with a spring **1282** retained inside the chamber **1280**. The piston **1234** extends through an opening **1284** in the chamber **1280** and has a pusher surface **1286** that is positioned adjacent one end of the spring **1282**. The chamber **1280** also has an inlet **1288** and an outlet **1290**. An inlet valve **1292** is provided inside a receptacle **1296** adjacent the inlet **1288** and the tubing **540**, and an outlet valve **1294** is provided inside a receptacle **1298** adjacent the outlet **1290** and the tubing **544**.

When the pump **542** is in the non-use position shown in FIG. **23**, the withdrawal of the piston **1234** in the direction of arrow FF creates a vacuum that draws liquid **530** into the chamber **1280**. This occurs because the vacuum draws the inlet valve **1292** upwardly, to allow liquid **530** to flow around the inlet valve **1292** to enter the chamber **1280**. The vacuum also pulls the outlet valve **1294** down to be seated over the outlet **1290** to prevent liquid **530** from exiting the chamber **1280**. When the piston **1234** is depressed in the direction of arrow RR (i.e., by pressing on the trigger **518**), as shown in FIG. **24**, the piston **1234** compresses the spring **1282**, creating a pressure that pushes the inlet valve **1292** downwardly in receptacle **1296** to block water flow into the chamber **1280**. The pressure also pushes the water inside the chamber **1280** out of the outlet **1290**, displacing the outlet valve **1294** from the outlet **1290**, and causing the liquid **530** to be delivered via the tubing **544** to the nozzle **546** for ejection. When the trigger **518** is released again, the spring load from the spring **1282** will bias the piston **1234** back in the forward direction of arrow FF, creating the vacuum to draw liquid **530** into the chamber **1280** again. Although FIGS. **23** and **24** illustrate one possible embodiment for the pump **542**, it is possible to use any available pump.

The operation of the assembly **500** will now be described. First, the user fills a liquid **530**, such as water, into the reservoir **528** via the cap **536**, the plug **534** and the opening **532**. The user then dips the bubble producing device **512** into a bubble solution, and holds the assembly **500** by inserting four fingers (except for the thumb) through the second opening **506**. The user can then use the thumb to press the push button **520** downwardly against the bias of the contacts **564** and **574** to cause the contacts **564** and **574** to pivot downwardly in a somewhat clockwise direction about their respective pivots **565** and **575** as shown in phantom in FIG. **22**. The pivoting of the contacts **564** and **574** will cause them to contact each other to form a closed circuit. The closed circuit will allow power to be provided to the motor **570** to drive the fan **510**, thereby generating a plurality of bubbles. Once the bubbles have been generated, the user can then pull or press the trigger **518** inwardly using an index finger to actuate the pump **542**, causing the liquid **530** from the reservoir **528** to be pumped via the pump **542** and the tubings **540** and **544** and through the nozzle **546** to create a spray or stream of liquid. The stream of liquid **530** can be aimed at the generated bubbles which act as targets. The user can simultaneously press both the push button **520** and the trigger **518** to generate liquid streams at the same time as bubbles are being generated.

When the user releases the push button **520**, the bias of the contacts **564** and **574** will separate the contacts **564** and **574**, thereby cutting power to the motor **570** to stop generating bubbles. When the user releases the trigger **518**, the bias of the spring **1282** in the pump **542** will push the trigger **518** towards the direction of the nozzle **546** so that so that the liquid **530** will cease from being pumped from the reservoir **528**.

Thus, the assembly **500** adds significant amusement value by giving the user the capability of shooting a stream of liquid at the bubbles that have been generated. In this manner, the assembly **500** can also be used as a bubble gun. In addition, the construction of the assembly **500** is simple and inexpensive.

FIG. **25** illustrates the same assembly **500** as in FIGS. **20-21**, but with a different bubble generating device **580**. The bubble producing device **580** is illustrated as having the same structure as the bubble producing device **404** of FIG. **19**, having only one primary ring to produce one large bubble at a time.

Similarly, FIG. **26** illustrates the same assembly **500** as in FIGS. **20-21**, but with a different bubble generating device **584**. The bubble producing device **584** is illustrated as having the same structure as the bubble producing device **28** of FIGS. **2-3**, having a primary ring and a plurality of vertically offset secondary rings.

FIG. **27** illustrates an assembly **600** that combines the principles illustrated in FIGS. **15-19** with the assembly **500** described in connection with FIGS. **20-22**. The assembly **600** is the same as assembly **500**, except that three separate sets of fans and motors are provided in the housing **602**. A separate bubble generating device **402x**, **404x** and **406x** (corresponding to bubble generating devices **402**, **404**, **406**, respectively, in FIG. **19**) is positioned over each fan and motor set. Thus, the user can use one push button **620** to simultaneously power the three separate sets of fans and motors to generate different types of bubbles at the same time from the three bubble generating devices **402x**, **404x** and **406x**. The user can then press the trigger **618** to create a stream of liquid through the nozzle **646** for shooting the created bubbles.

13

While the description above refers to particular embodiments of the present invention, it will be understood that many modifications may be made without departing from the spirit thereof. The accompanying claims are intended to cover such modifications as would fall within the true scope and spirit of the present invention.

What is claimed is:

1. A bubble producing assembly, comprising:
 - a housing;
 - an air generator fixedly secured to the housing;
 - a frame positioned adjacent the air generator and having one to four legs, with each leg connecting the frame to the housing;
 - two to four bubble producing devices, each bubble producing device having at least one loop; and
 - wherein the bubble producing devices are positioned in spaced-apart manner, and on the same plane, on the frame.
2. The assembly of claim 1, wherein at least one loop of at least one bubble producing device has a plurality of ridges provided thereon.
3. The assembly of claim 1, wherein the frame defines an opening with one of the bubble producing devices positioned over the opening.
4. The assembly of claim 3, wherein the assembly further includes a fan positioned inside the opening.
5. The assembly of claim 1, wherein the two to four bubble producing devices comprises exactly four bubble producing devices.

14

6. The assembly of claim 1, wherein the one to four legs comprises exactly four legs.
7. A bubble producing assembly, comprising:
 - a housing having an outlet;
 - an air generator associated with the housing;
 - a motor coupled to the air generator;
 - a bubble producing device positioned adjacent the air generator and spaced apart from the outlet;
 - a first activator coupled to the air generator;
 - a reservoir associated with the housing for storing a liquid;
 - a pump system coupling the reservoir and the outlet;
 - a second activator coupled to the pump system for delivering the liquid from the reservoir out of the outlet; and
 - wherein the pump system utilizes air pressure for delivering the liquid from the reservoir out of the outlet.
8. The assembly of claim 7, further including a power source coupled to the air generator and the first activator.
9. The assembly of claim 7, wherein the pump system delivers a stream of liquid out of the outlet.
10. The assembly of claim 7, wherein the first activator and the second activator are positioned outside the housing.

* * * * *