



US007011442B2

(12) **United States Patent**
Okuwaki et al.

(10) **Patent No.:** **US 7,011,442 B2**
(45) **Date of Patent:** **Mar. 14, 2006**

(54) **PLANAR LIGHT SOURCE**

(75) Inventors: **Daisaku Okuwaki**, Yamanashi (JP);
Junji Miyashita, Yamanashi (JP)

(73) Assignee: **Citizen Electronics Co., Ltd.**,
Yamanashi (JP)

(*) Notice: Subject to any disclaimer, the term of this
patent is extended or adjusted under 35
U.S.C. 154(b) by 169 days.

(21) Appl. No.: **10/689,733**

(22) Filed: **Oct. 22, 2003**

(65) **Prior Publication Data**
US 2004/0085750 A1 May 6, 2004

(30) **Foreign Application Priority Data**
Oct. 22, 2002 (JP) P2002-307698

(51) **Int. Cl.**
F21V 7/04 (2006.01)

(52) **U.S. Cl.** **362/626; 362/623; 362/621**

(58) **Field of Classification Search** 362/31,
362/26, 558, 559, 246, 330, 800, 607, 608,
362/609, 612, 613, 615, 616, 620, 623, 625,
362/626; 349/65, 67

See application file for complete search history.

(56) **References Cited**

U.S. PATENT DOCUMENTS

5,359,691	A *	10/1994	Tai et al.	385/146
5,659,410	A *	8/1997	Koike et al.	349/62
5,712,694	A *	1/1998	Taira et al.	349/9
6,443,583	B1 *	9/2002	Ha	362/608
6,572,236	B1 *	6/2003	Suzuki et al.	362/600
2001/0036068	A1 *	11/2001	Suzuki et al.	362/31

FOREIGN PATENT DOCUMENTS

JP 2003-294954 A 10/2003

* cited by examiner

Primary Examiner—Sandra O’Shea

Assistant Examiner—Gunyoung T. Lee

(74) *Attorney, Agent, or Firm*—Browdy and Neimark,
PLLC

(57) **ABSTRACT**

A planar light source of this invention is formed with chamfered portions at an upper end of the light receiving side surface where the light receiving side surface and the light emitting surface of the light guide plate intersect and at a lower end of the light receiving side surface where the light receiving side surface and the reflection surface of the light guide plate intersect. The chamfered portions can make indistinguishable the bright lines, that may be produced during illumination, to prevent a dark-bright fringe pattern from showing up, thereby preventing a possible degradation of liquid crystal display quality.

6 Claims, 11 Drawing Sheets

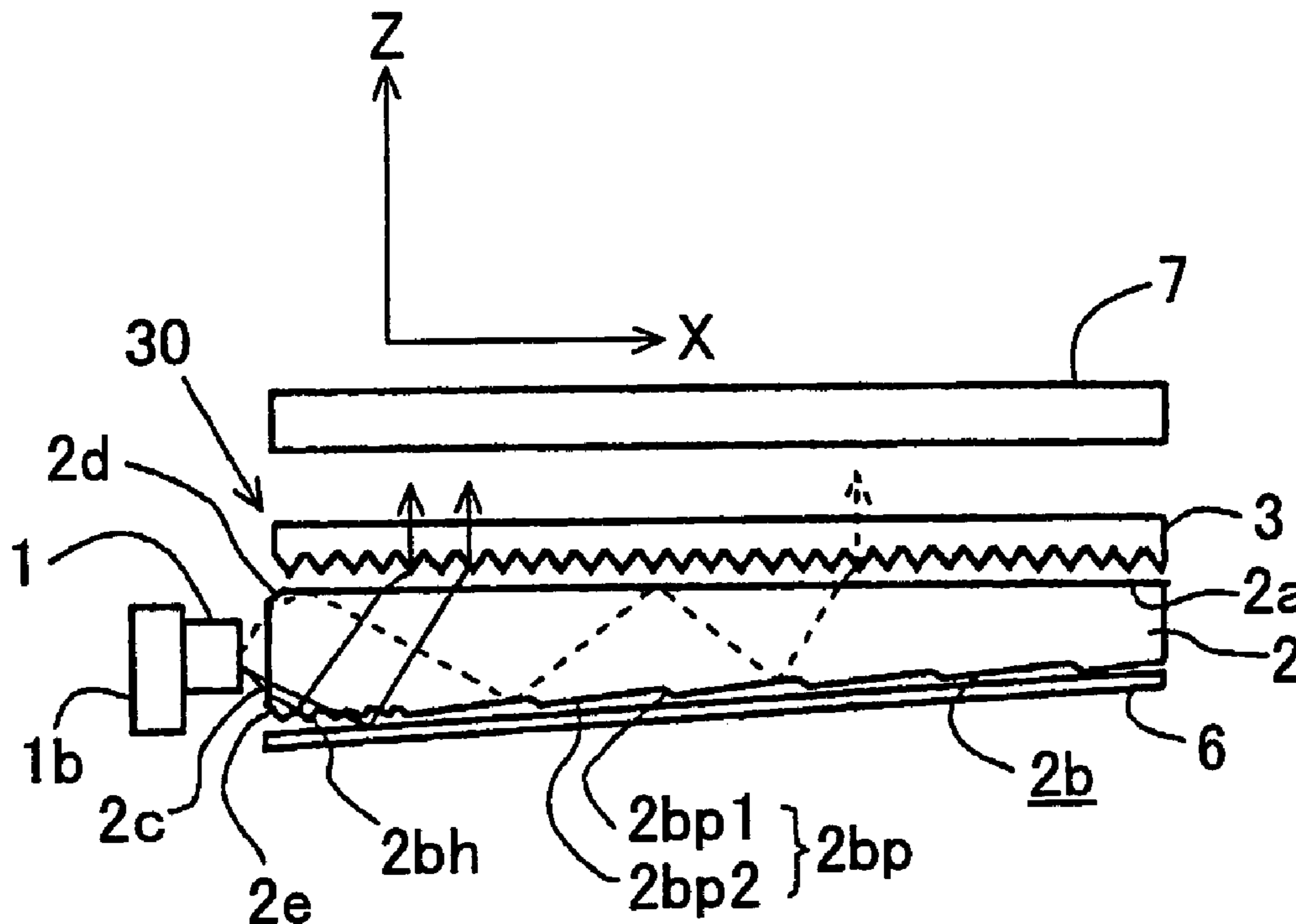

Fig . 1

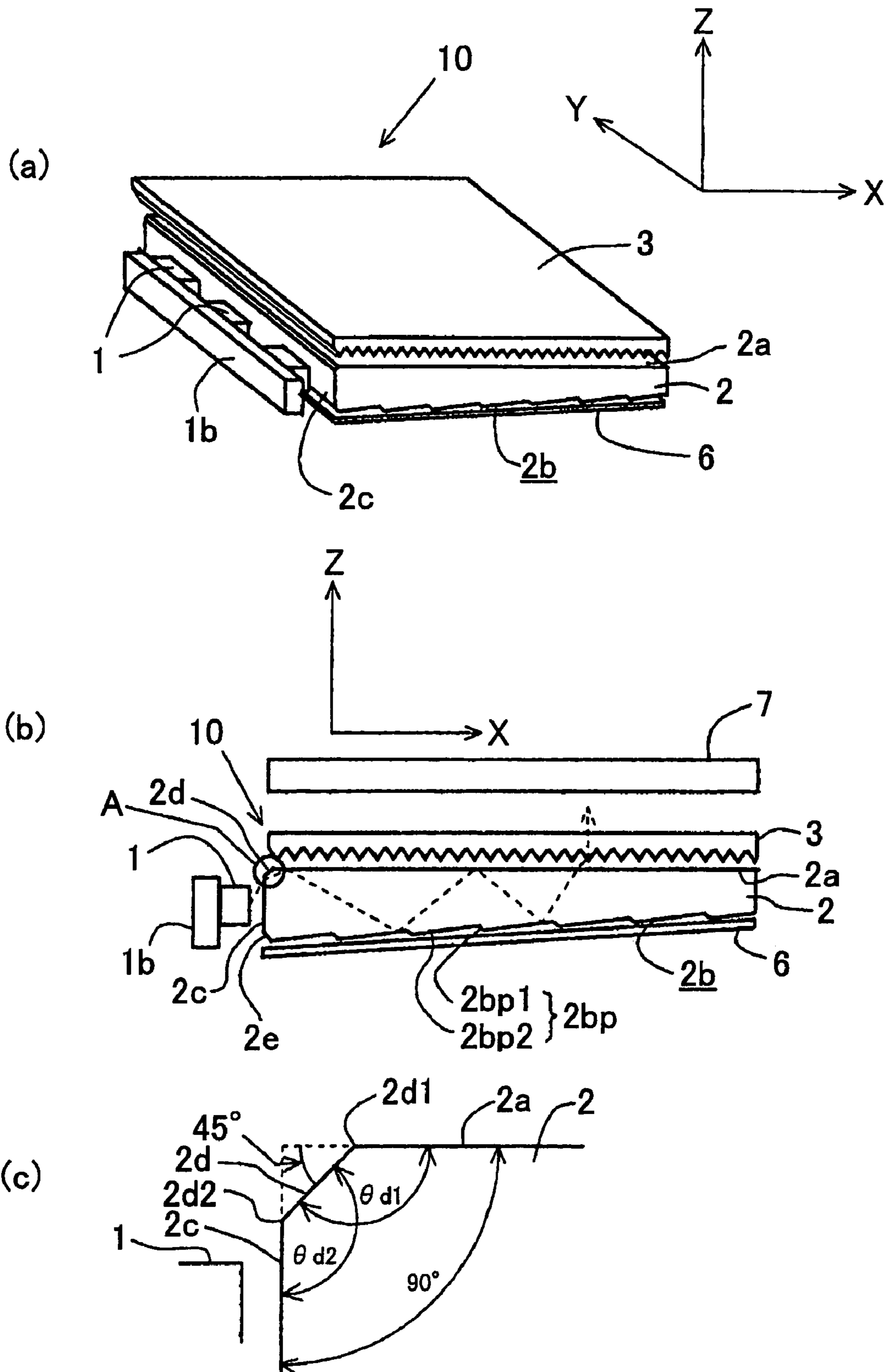

Fig . 2

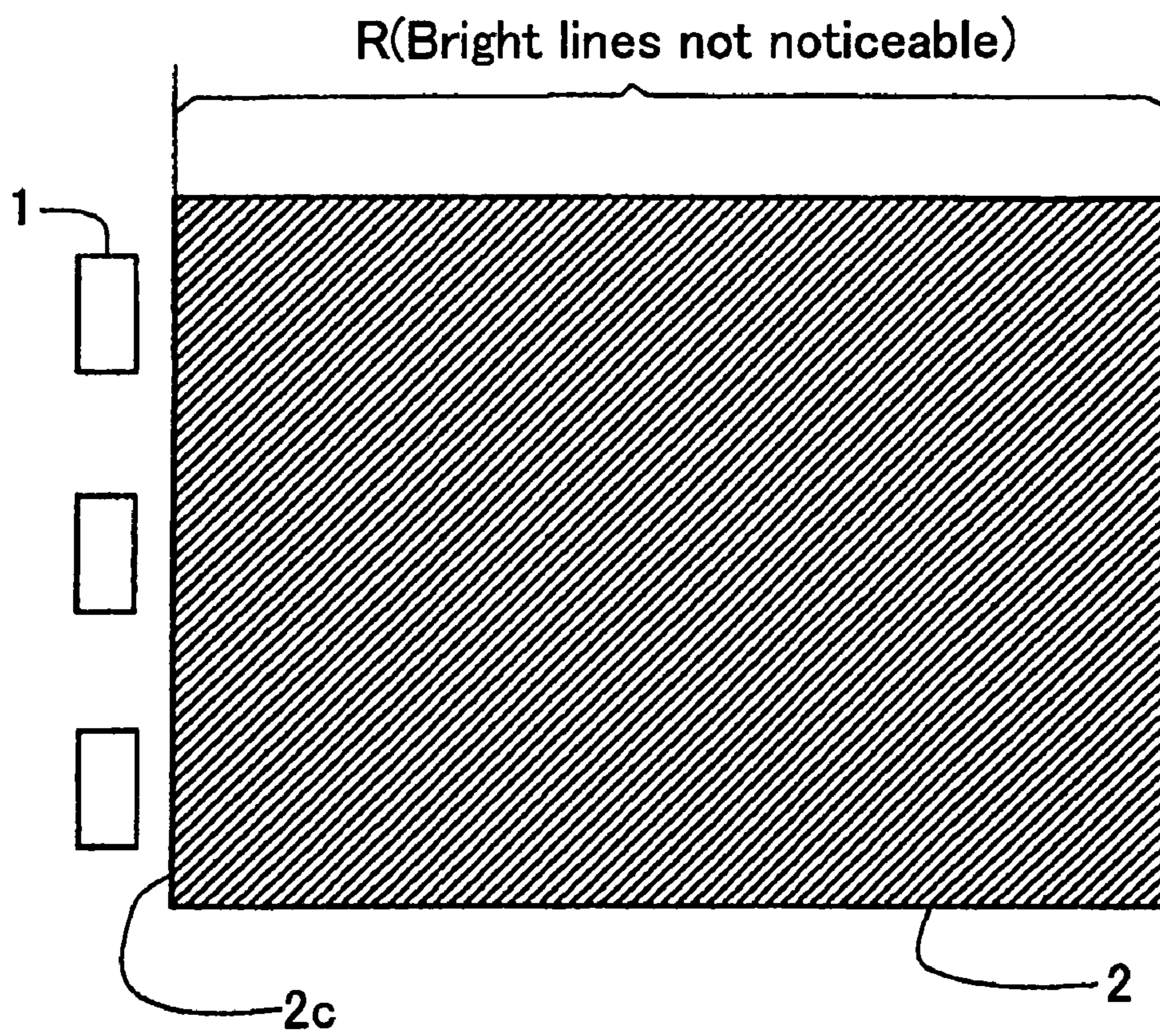

Fig . 3

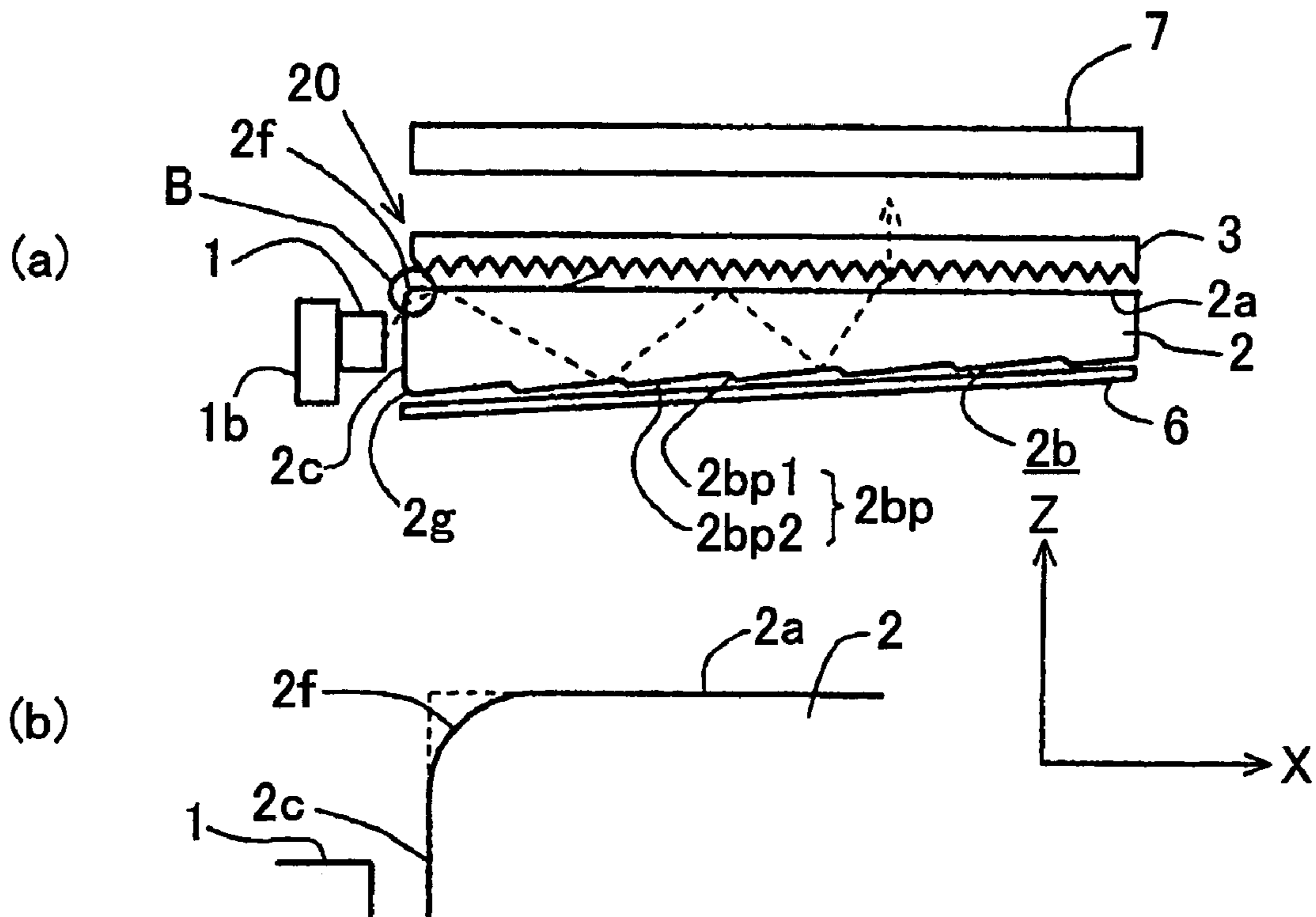

Fig . 4

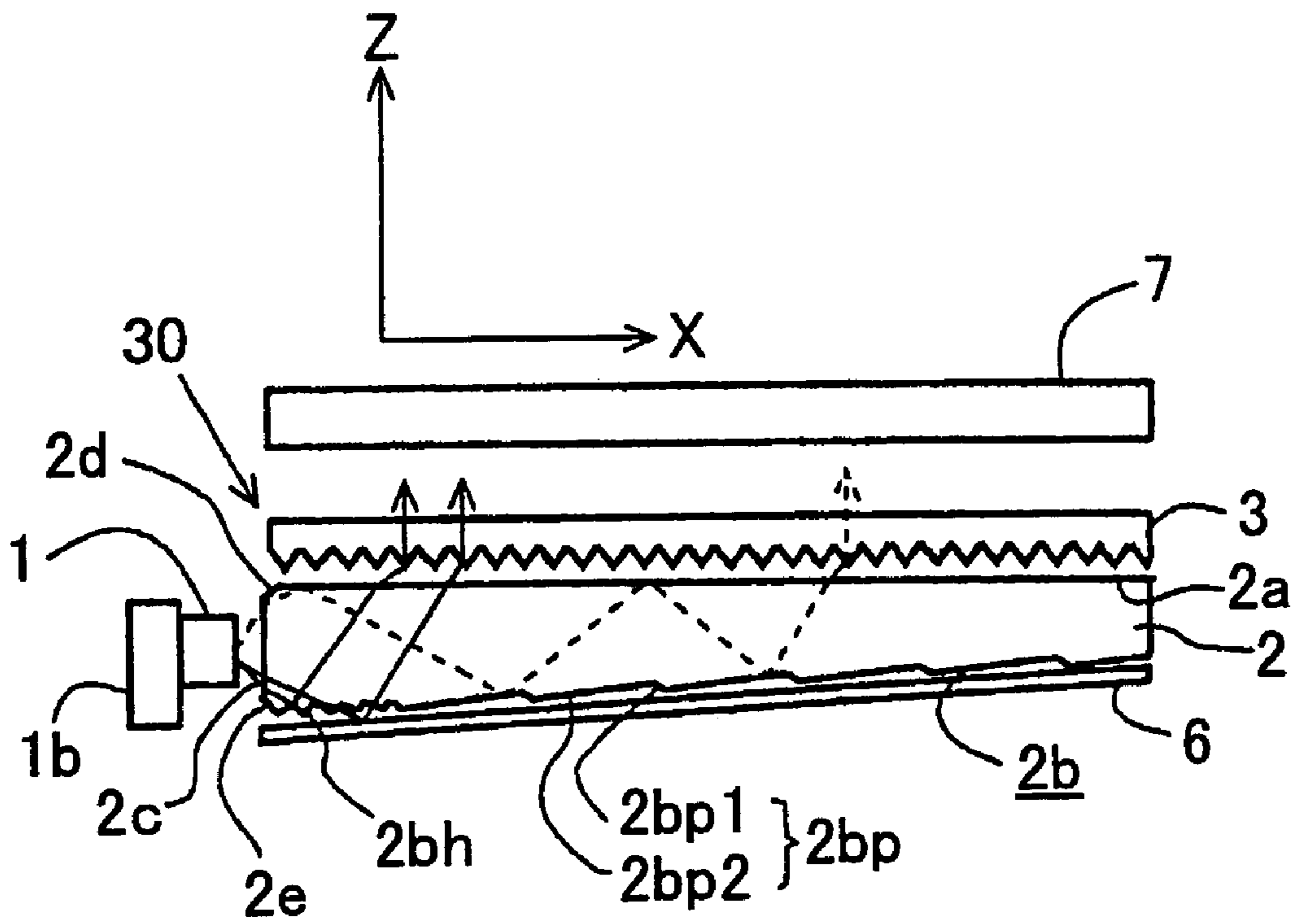

Fig . 5

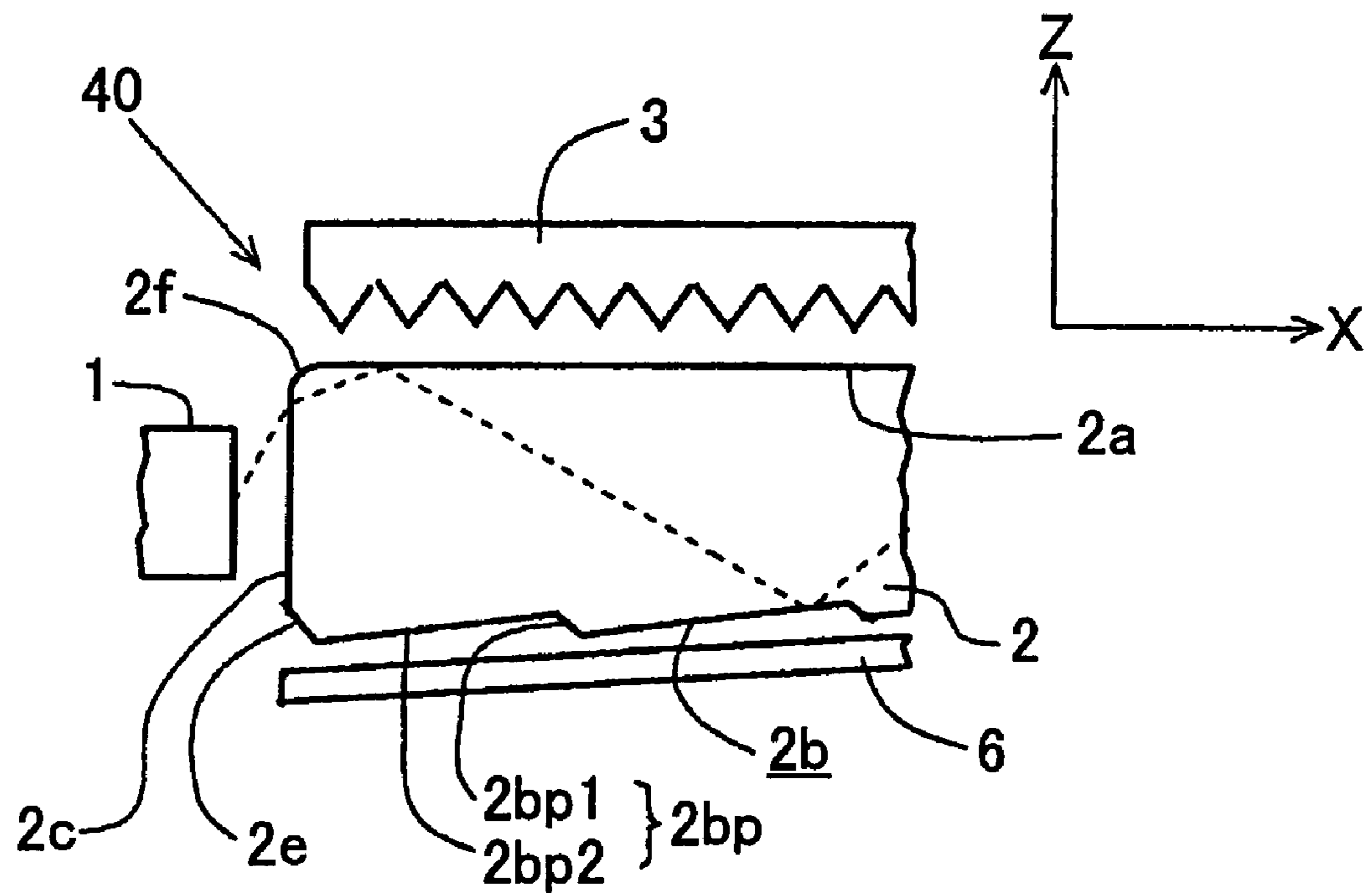

Fig . 6

(Prior Art)

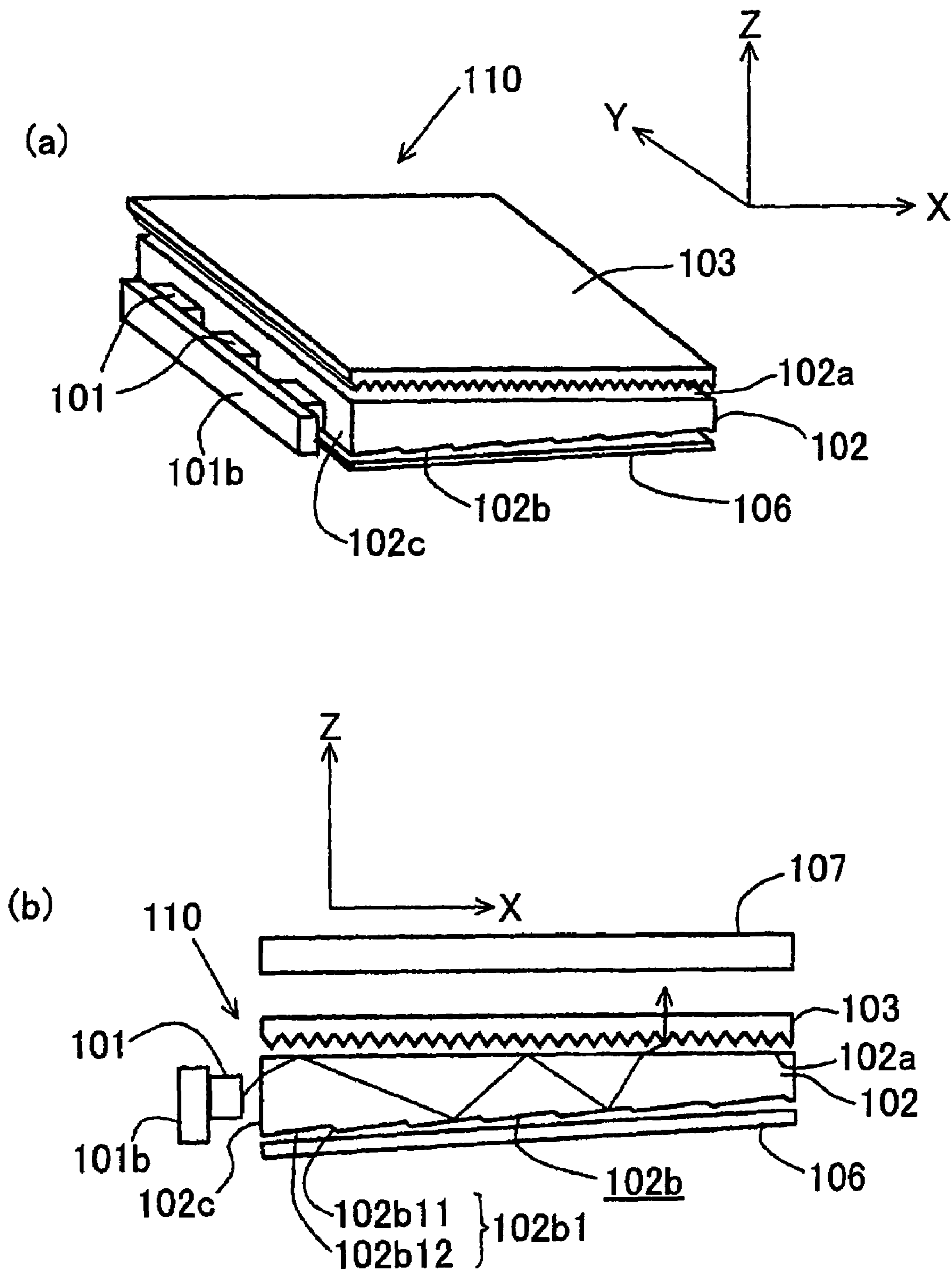

Fig . 7
(Prior Art)

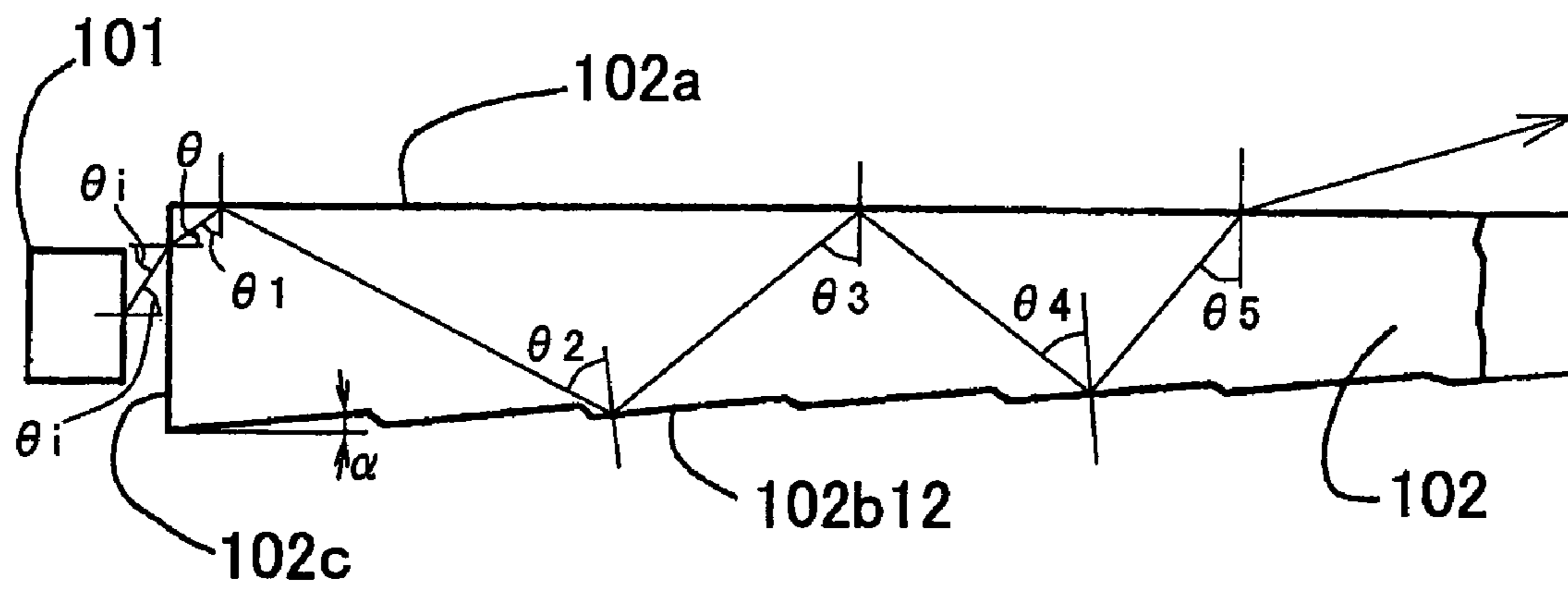

Fig . 8
(Prior Art)

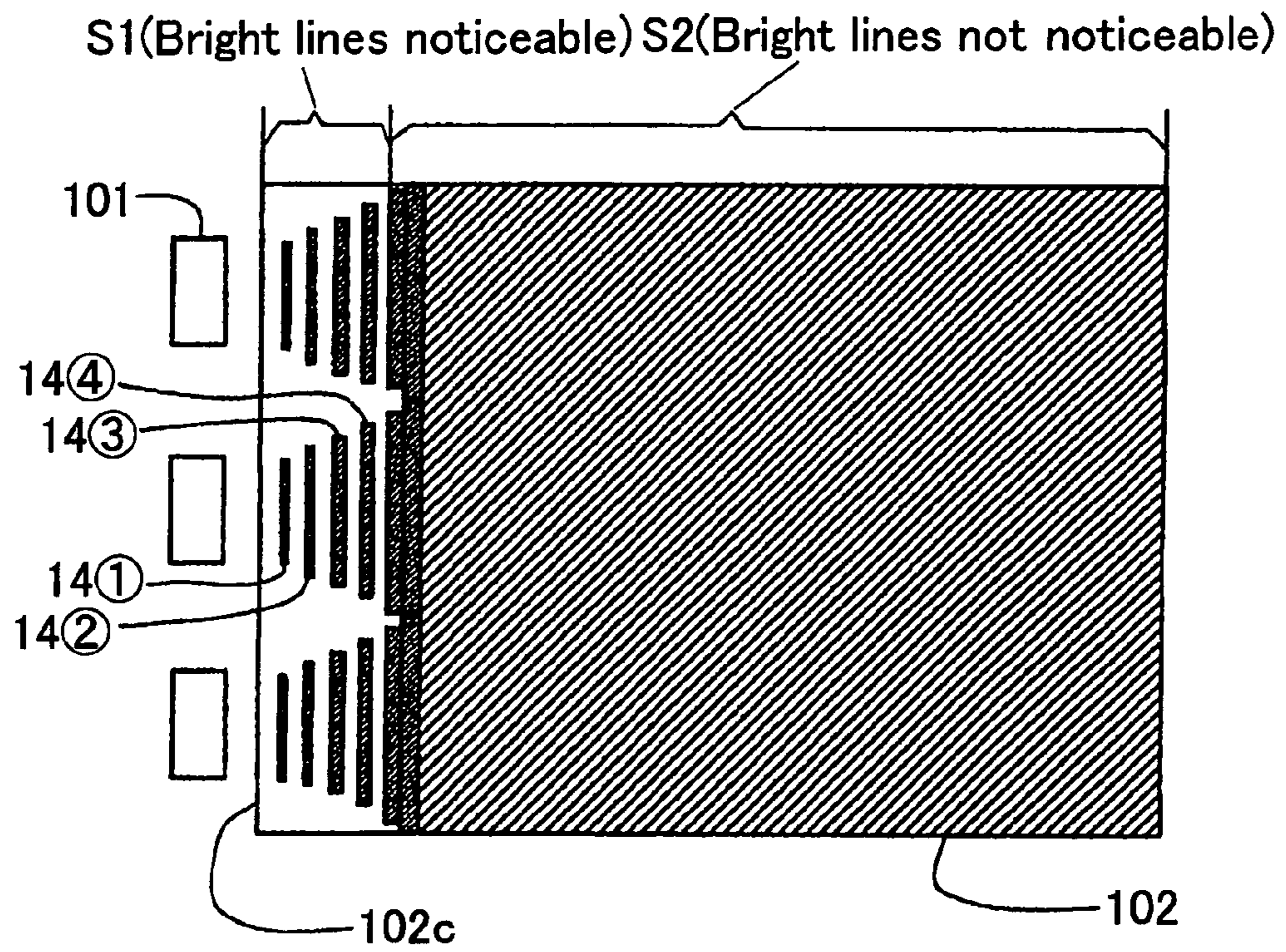

Fig . 9
(Prior Art)

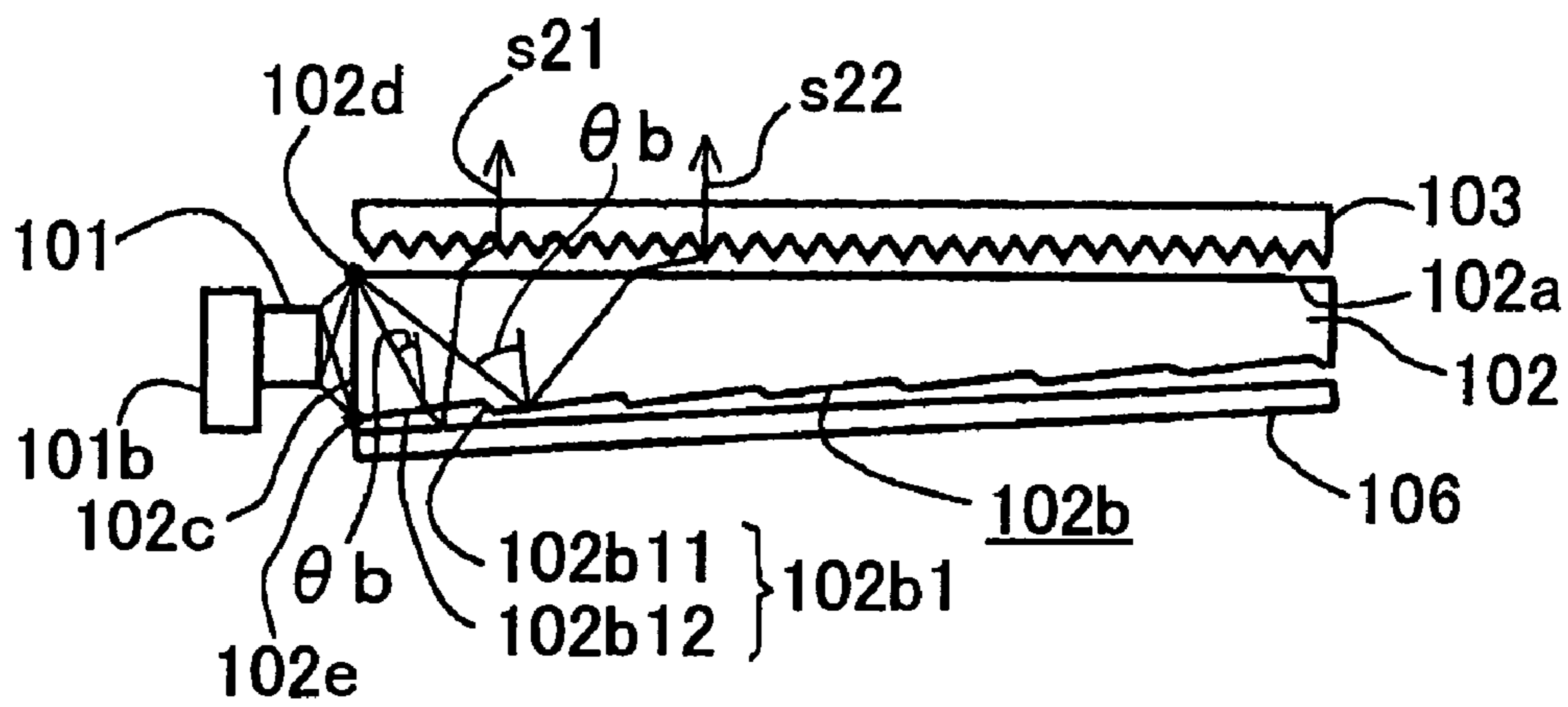

Fig . 1 0
(Prior Art)

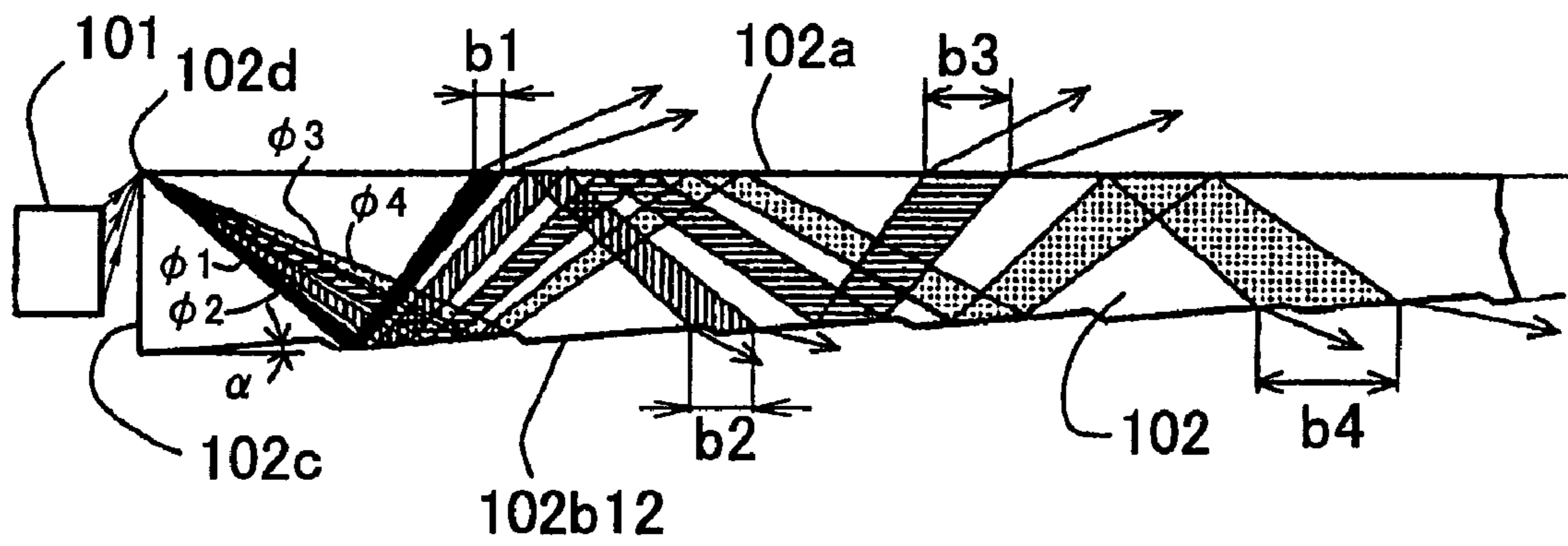
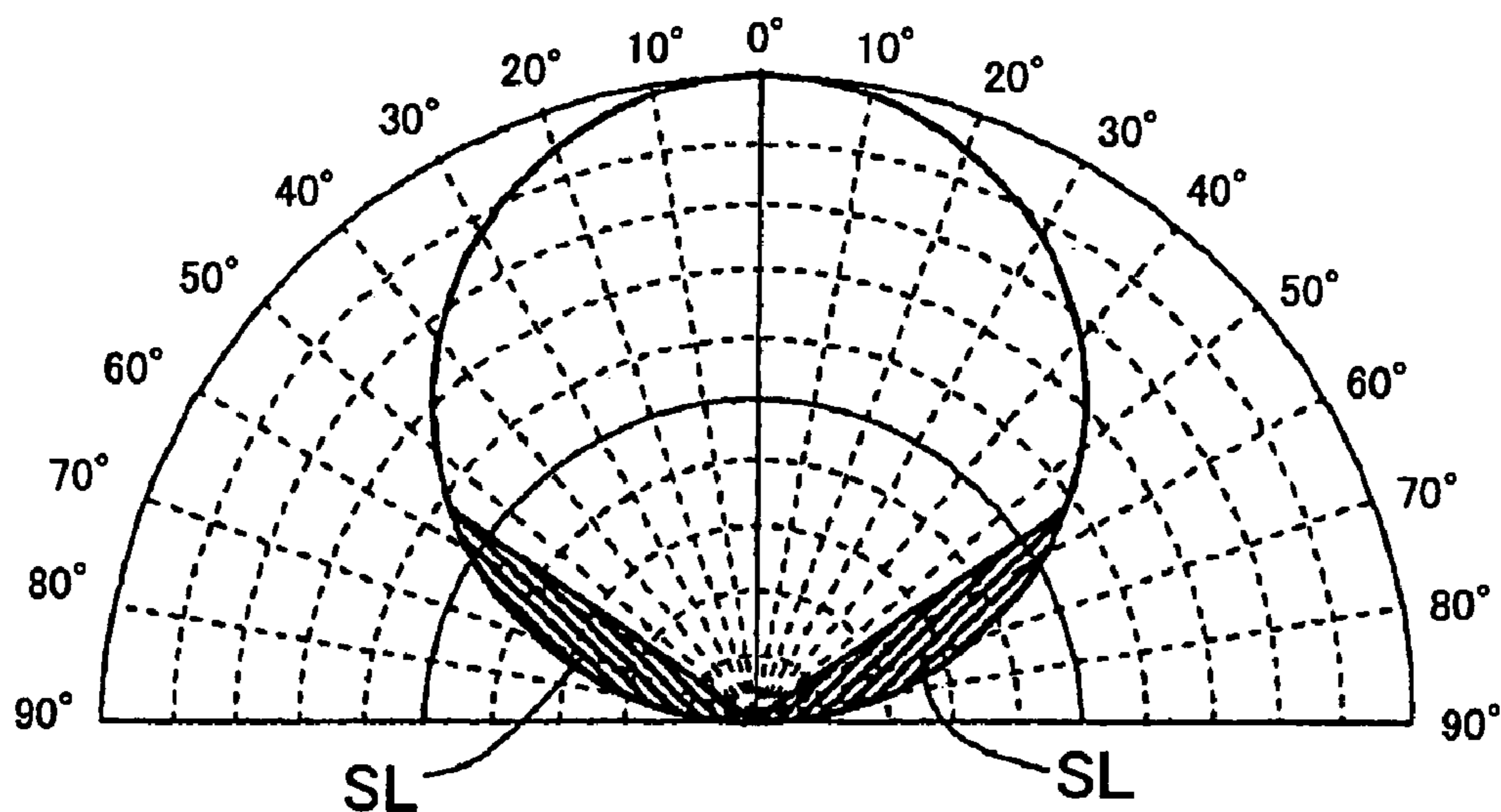

Fig . 1 1



Directivity characteristic of light source

1

PLANAR LIGHT SOURCE

BACKGROUND OF THE INVENTION

1. Field of the Invention

The present invention relates to a planar light source for illuminating a liquid crystal panel and the like from their back.

2. Description of the Prior Art

Small liquid crystal displays have been used in recent years in cellular phones and other portable information terminals and, as a means for illuminating such liquid crystal displays, a planar light source is used. The planar light source is constructed of a plate-like light guide plate and light emitting diodes (LEDs) arranged to face a side surface of the light guide plate. Thanks to its ability to be reduced easily in size and thickness, the planar light source has found wide uses.

In the planar light source, light emitted from the LEDs enters into the light guide plate and propagates as it is repetitively reflected within the light guide plate. The light is reflected or refracted by grooves or a textured pattern formed in an underside of the light guide plate until it goes out of the plate. The light emitted from the top surface of the light guide plate travels toward and illuminates the liquid crystal display.

An example of such a conventional planar light source is shown in FIG. 6 (e.g., Japanese Patent Application No. 2002-093383, FIG. 7). FIG. 6 illustrates a construction of a planar light source **110** which has LEDs **101** as a light source, a light guide plate **102**, a prism sheet **103**, a reflector plate **106** and a liquid crystal panel **107**. The light guide plate **102** is rectangular and made of a light-transmitting glass or resin. Denoted **102a** is a top surface of the light guide plate **102**. Designated **102c** is a light receiving side surface facing the LEDs **101**. Designated **102b** is a bottom surface of the light guide plate **102**. The bottom surface **102b** is formed with a plurality of asymmetric prisms **102b1** facing the top surface **102a**. The asymmetric prisms **102b1** each comprise a down slope **102b11** whose distance to the top surface **102a** sharply increases as it moves away from the light receiving side surface **102c** and an up slope **102b12** whose distance to the top surface **102a** moderately decreases. Arranged opposite the light receiving side surface **102c** are three LEDs **101** supported on a retainer member **101b**.

When a predetermined amount of electricity is supplied from a power supply not shown to the LEDs **101**, the LEDs **101** illuminate in white or a predetermined color. The light emitted from the LEDs **101** is refracted by the light receiving side surface **102c** as it enters the light guide plate **102**. The light that has entered the light guide plate **102** is repetitively reflected between the top surface **102a** and the bottom surface **102b** of the light guide plate **102** before it is refracted by the top surface **102a** and leaves the light guide plate **102**. The light then enters the prism sheet **103**, in which it is specular-reflected until its propagation direction is changed to a Z direction. The light traveling in the Z direction is now incident on the liquid crystal panel **107**. Therefore, the light passes through the liquid crystal in an ideal direction, making a clear and vivid image display possible.

FIG. 7 is a side view showing a path of light emitted from the LEDs **101** that has entered the light guide plate **102**. In the figure, a light ray emitted from the LEDs **101** at an output or emittance angle of θ_i enters the light receiving side surface **102c** of the light guide plate **102** at an incidence angle of θ_i . At this time, the ray is refracted on this plane and a relationship between the incidence angle θ_i and a refracted

2

angle θ is, according to Snell's law, $n \cdot \sin \theta = \sin \theta_i$ assuming that a refractive index of air is 1 and a refractive index of the light guide plate **102** (made of polycarbonate and the like) is n . From this we obtain

$$\theta = \sin^{-1}((1/n) \sin \theta_i) \quad (1)$$

If, for example, the light guide plate **102** has a refractive index of $n=1.58$ and $\theta_i=90^\circ$, calculating the equation (1) results in $\theta = \sin^{-1}(1/1.58) = 39.3^\circ$ and thus the critical angle θ_c is $\theta_c = 39.3^\circ$.

It should be noted, however, that since the incidence angle in reality is less than 90° at maximum, the refracted angle θ even at its maximum is less than the critical angle θ_c . The critical angle θ_c of the light guide plate **102** is generally around 40° , so the refracted angle θ even at its maximum does not exceed 40° . The light ray that has passed through the light receiving side surface **102c** at the refracted angle θ is incident on the top surface **102a** of the light guide plate **102** at an incidence angle θ_1 . At this time, as can be seen from FIG. 7, since a relation of $(\theta + \theta_1 = 90^\circ)$ holds and the refracted angle θ is equal to or less than 40° , as described above, the incidence angle θ_1 is equal to or more than 50° , which is larger than the critical angle θ_c of around 40° . Thus, the ray incident on the top surface **102a** is totally reflected at a reflection angle θ_1 .

The reflected light then strikes, at an incidence angle of $\theta_2 = \theta_1 - \alpha$, the up slope **102b12** of the bottom surface which has an inclination angle of α . Here the inclination angle α is about 1° to several degrees.

The ray that has struck the up slope **102b12** at an incidence angle θ_2 is reflected by this surface at a reflection angle θ_2 and then strikes the top surface **102a** at an incidence angle of $\theta_3 = \theta_2 - \alpha = \theta_1 - 2\alpha$. The ray is then reflected by the top surface **102a** at a reflection angle θ_3 to hit the up slope **102b12** at an incidence angle of $\theta_4 = \theta_3 - \alpha = \theta_1 - 3\alpha$. Each time the light ray, that was first reflected by the top surface **102a** at a reflection angle θ_1 , strikes the up slope **102b12** or the top surface **102a**, its incidence angle decreases by an amount equal to the inclination angle α . That is, when the ray, that was first reflected at a reflection angle of θ_1 , strikes the up slope **102b12** or top surface **102a** for an Nth time after repetitive reflections, its incidence angle θ_N is given by

$$\theta_N = \theta_1 - (N-1)\alpha \quad (2)$$

In this light guide plate, the light incidence or reflection on its boundary surface, shown at θ_1 , is counted as the first incidence/reflection (i.e., $N=1$).

When the decreasing incidence angle θ_N has the following relation with the critical angle θ_c :

$$\theta_N = \theta_1 - (N-1)\alpha < \theta_c \quad (3)$$

then, the ray passes through the top surface **102a** or the up slope **102b12** of the bottom surface **102b** and gets out of the light guide plate **102**. For example, if $\theta_1 = 52^\circ$, $\alpha = 1^\circ$ and $\theta_c = 40^\circ$, the condition of equation (3) is met when N is more than 13. This means that the light ray must strike the top or bottom surface of the light guide plate **102** fourteen times or more. Therefore, near the light receiving side surface **102c** the ray does not escape to the outside. For example, if the light guide plate **102** has a thickness of 1 mm, the ray does not exit the light guide plate **102** from within about 3 mm of the light receiving side surface **102c** but normally exits from a region more than 3 mm away from the light receiving side

3

surface **102c**. In the region from which the light ray exits normally, there are no light intensity variations.

However, conventional backlight units using such a light guide plate **102** often have the following problems. As shown in a plan view of FIG. **8**, in an area **S1** within 3–4 mm of the light receiving side surface **102c** of the light guide plate **102** several bright lines show up (in FIG. **8** the bright lines are shown hatched with thick lines). **S2** represents an area where bright lines do not show. The conspicuous bright lines **14** are considered to be caused as follows. As shown in FIG. **10**, rays of light emitted from the LEDs **101** enter the light guide plate **102** from an edge portion **102d** where the light receiving side surface **102c** and the top surface **102a** of the light guide plate **102** cross each other.

In FIG. **11** representing a “light source directivity of LED,” those of the rays emitted from LEDs **101** which reach the edge portion **102d** are light traveling in a direction that corresponds to a region **SL** shown hatched.

If the edge portion **102d** has a rough surface, rather than a mirror surface, the light rays from the LEDs **101** enter the edge portion **102d** not through normal refraction but through scattering. That is, from the edge portion **102d** a plurality of rays travel through the light guide plate **102** in different directions, making the edge portion **102d** look as if it were illuminating. Thus, the edge portion **102d** can be regarded as a secondary light source. A similar secondary light source also occurs at a lower edge portion **102e** of the light guide plate **102** where the light receiving side surface **102c** and the bottom surface **102b** intersect. In the conventional light guide plate **102** the edge portions **102d**, **102e** are formed almost at right angles, so their transferability in a molding process is bad, making their surface rough, which in turn results in secondary light sources being easily formed.

As to the secondary light source illuminating at the edge portion **102d**, an incidence angle θ_b that the light from the secondary light source has with respect to the up slope **102b12** of the bottom surface **102b** can be smaller than the critical angle θ_c , as shown in FIG. **9**. In that case, as illustrated by a ray **s21**, the light ray passes through the up slope **102b12** and is then reflected by the reflector plate **106** under the slope to reenter the light guide plate **102** and pass through the top surface **102a**, illuminating the light guide plate **102** upward. Because the range of this light emission is wide, no bright lines are produced.

In a case where the incidence angle θ_b is larger than the critical angle θ_c , the ray is reflected by the up slope **102b12** and exits through the top surface **102a**, as indicated by a ray **s22**. The number of times that the ray strikes, as by reflection, the top or bottom surface before it exits, the light guide plate **102** varies depending on a difference between the incidence angle θ_b and the critical angle θ_c , as explained above. As the difference increases, so does the number of times the ray needs to strike the top or bottom surface. This is described in more detail by referring to FIG. **10**. In FIG. **10**, ϕ_1 , ϕ_2 , ϕ_3 and ϕ_4 represent light fluxes emanating from the edge portion **102d** and an angular range of each flux is assumed to be smaller than the inclination angle α of the up slope **102b12**. Concerning refracted angles of these light fluxes on the top surface **102a** as they exit the light guide plate **102**, it is assumed that the refracted angle of the light flux ϕ_1 is the smallest, with those of ϕ_2 , ϕ_3 and ϕ_4 progressively increasing in that order in steps of the inclination angle α .

Let the refracted angles of the light fluxes ϕ_1 , ϕ_2 , ϕ_3 and ϕ_4 be θ_{d1} , θ_{d2} , θ_{d3} and θ_{d4} respectively. These refracted

4

angles are assumed to have the following relations with the critical angle θ_c :

$$\begin{aligned}\theta_{d1} &= 1.5\alpha + \theta_c \\ \theta_{d2} &= 2.5\alpha + \theta_c \\ \theta_{d3} &= 3.5\alpha + \theta_c \\ \theta_{d4} &= 4.5\alpha + \theta_c\end{aligned}\quad (4)$$

As shown in FIG. **10**, all of the light fluxes ϕ_1 , ϕ_2 , ϕ_3 , ϕ_4 strike for a first time the boundary surface, or the up slope **102b12**, and their incidence angles at this time are

$$\theta_{d1}-\alpha, \theta_{d2}-\alpha, \theta_{d3}-\alpha \text{ and } \theta_{d4}-\alpha$$

respectively. From equation (4), all these incidence angles are larger than the critical angle θ_c and therefore reflected by the up slope **102b12**. The reflected light fluxes strike for a second time the boundary surface, or the top surface **102a**, and their incidence angles at this time are:

$$\theta_{d1}-2\alpha < \theta_c, \theta_{d2}-2\alpha > \theta_c, \theta_{d3}-2\alpha > \theta_c \text{ and } \theta_{d4}-\alpha > \theta_c.$$

Only the incidence angle of the light flux ϕ_1 , $\theta_{d1}-2\alpha$, is less than the critical angle θ_c and this flux ϕ_1 with a width b_1 exits from the top surface **102a**.

The remaining fluxes ϕ_2 , ϕ_3 , ϕ_4 are reflected by the top surface **102a** and are incident for a third time on the boundary surface, this time the up slope **102b12**, and from equation (4) their incidence angles are:

$$\theta_{d2}-3\alpha < \theta_c, \theta_{d3}-3\alpha > \theta_c \text{ and } \theta_{d4}-3\alpha > \theta_c.$$

Only the incidence angle of the light flux ϕ_2 , $\theta_{d1}-3\alpha$, is less than the critical angle θ_c and the flux ϕ_2 with a width b_2 exits from the up slope **102b12**. Similarly, a fourth striking on the boundary surface results in the light flux ϕ_3 with a width b_3 exiting from the top surface **102a**. On a fifth striking, the flux ϕ_4 exits from the up slope **102b12** in a width b_4 .

As described above, these fluxes successively escape outside according to the number of times the light has struck the boundary surfaces. The width of the light flux as it leaves the light guide plate **102** progressively increases according to the number of boundary surface striking times. The light flux widths has the following relation:

$$b_1 < b_2 < b_3 < b_4.$$

This may be explained as follows. Although the fluxes ϕ_1 , ϕ_2 , ϕ_3 , ϕ_4 have the same angular range, the actual width of each flux increases in proportion to the length of flux path. The larger the number of times the flux strikes the boundary surfaces, the longer the flux path and the larger the actual width of the flux. In FIG. **10**, the flux that has escaped from the up slope **102b12** of the bottom surface is reflected by the reflector plate **106** as shown in FIG. **9** and reenters the light guide plate **102** before exiting the top surface **102a**. It is thus considered possible to deal with this light flux in the same way as if it first exited from the top surface **102a**.

In the following discussion, the outgoing light rays of the fluxes ϕ_1 , ϕ_2 , ϕ_3 , ϕ_4 of FIG. **10** are considered in relation to the bright lines **14**①, **14**②, **14**③, **14**④ shown in FIG. **8**. An exit light of the flux ϕ_1 with the width b_1 shown in FIG. **10** is situated closest to the light receiving side surface **102c** and its width is narrowest, so that it is considered to correspond to the bright line **14**① of FIG. **8**. An exit light of the flux ϕ_2 with the width b_2 shown in FIG. **10** is situated second closest to the light receiving side surface **102c** and its width is slightly wider than b_1 . So, this flux is considered to match the bright line **14**② of FIG. **8**. Similarly, exit light of

5

the fluxes ϕ_3 , ϕ_4 shown in FIG. 10 is considered to correspond to the bright lines 14③, 14④, respectively.

If the refracted angle of the flux ϕ_4 on the top surface 102a shown in FIG. 10 increases, the number of times that the flux strikes the boundary surface before it exits the light guide plate 102 also increases and the position at which it leaves the light guide plate 102 is further away from the light receiving side surface 102c, increasing the width of the outgoing flux, which in turn is considered to reduce a light quantity per unit area or brightness. This agrees with the fact that, as the bright lines shown hatched with thick lines in the FIG. 8 plan view of the light guide plate 102 move away from the light receiving side surface 102c, the width of the bright lines increases, making them less conspicuous. Therefore, the marked bright lines such as shown in FIG. 8 are considered to be caused by the presence of those light rays emitted from the edge portion 102d which go out of the light guide plate 102 with a relatively small number of boundary surface striking times (1–4 times).

In the above description the edge portion 102d of FIG. 9 has been described to be a secondary light source. In a case where the lower edge portion 102e functions as a secondary light source, too, light rays with their incidence angles on the top surface 102a greater than the critical angle produce bright lines according to the same principle described above. These bright lines tend to become more conspicuous when a member for restricting a direction of light, such as the prism sheet 103 of FIG. 6 or diffusion sheet (not shown), is installed above the light guide plate 102. Although the above description has taken up, as an example case of bright lines, a construction in which a reflection surface of the bottom surface 102b of the light guide plate 102 is formed of asymmetric prisms 102b1, the principle of bright line generation also applies to other constructions in which the reflection surface on the bottom surface 102b of the light guide plate 102 is formed of symmetric prisms or formed with a regular or irregular pattern of recessed and raised portions formed by printing, surface texturing or dot formation. That is, even in these cases, as long as a secondary light source is produced at the edge portions 102d, 102e of the light guide plate 102, there is a problem that bright lines show up when the light guide plate 102 is illuminated. When these bright lines are produced, bright and dark fringes show up, marring the appearance of the planar light source.

SUMMARY OF THE INVENTION

The present invention has been accomplished to overcome the aforementioned problems experienced with the conventional art and provides a planar light source which has a light guide plate and an illuminating light source, such as LEDs, arranged opposite a side surface of the light guide plate and which can prevent a formation of a dark-bright fringe pattern caused by bright lines.

As a first means to achieve the above objective, the present invention provides a planar light source comprising: a light guide plate made of a platelike, light-transmitting material formed with a light emitting surface on a top side thereof and a reflection surface on a bottom side thereof; and an illuminating light source arranged opposite a light receiving side surface of the light guide plate; wherein light coming from the illuminating light source into the light receiving side surface of the light guide plate is light-path-transformed by actions of the reflection surface and the light emitting surface of the light guide plate to emit a planar light flux from the light emitting surface; wherein chamfered portions are provided at an upper end of the light receiving

6

side surface where the light receiving side surface and the light emitting surface of the light guide plate intersect and at a lower end of the light receiving side surface where the light receiving side surface and the reflection surface of the light guide plate intersect.

As a second means to achieve the above objective, the present invention provides a planar light source wherein curved portions are provided at an upper end of the light receiving side surface where the light receiving side surface and the light emitting surface of the light guide plate intersect and at a lower end of the light receiving side surface where the light receiving side surface and the reflection surface of the light guide plate intersect.

As a third means to achieve the above objective, the present invention provides a planar light source wherein a chamfered portion is provided either at an upper end of the light receiving side surface where the light receiving side surface and the light emitting surface of the light guide plate intersect or at a lower end of the light receiving side surface where the light receiving side surface and the reflection surface of the light guide plate intersect, and a curved portion is provided at the other end.

In one embodiment, a member for restricting a light transmission direction is arranged opposite the light emitting surface of the light guide plate and the light transmission direction restricting member is a prism sheet.

In one embodiment, the reflection surface of the light guide plate is formed at least partly of a plurality of prisms.

In another embodiment, the reflection surface of the light guide plate has a surface-textured reflection surface and a reflection surface formed of a plurality of prisms.

BRIEF DESCRIPTION OF THE DRAWINGS

FIG. 1 is an explanatory diagram showing a planar light source according to a first embodiment of the present invention.

FIG. 2 is a plan view of the planar light source of FIG. 1.

FIG. 3 is an explanatory diagram showing a planar light source according to a second embodiment of the present invention.

FIG. 4 is an explanatory diagram showing a planar light source according to a third embodiment of the present invention.

FIG. 5 is an explanatory diagram showing a planar light source according to a fourth embodiment of the present invention.

FIG. 6 is an explanatory diagram showing a backlight unit using a conventional light guide plate.

FIG. 7 is an explanatory diagram showing a normal reflection path in the conventional light guide plate of FIG. 6.

FIG. 8 is a plan view showing a state of illuminating light in the conventional light guide plate of FIG. 6.

FIG. 9 is an explanatory diagram showing an abnormal reflection path in the conventional light guide plate of FIG. 6.

FIG. 10 is an explanatory diagram showing the abnormal path of light in the light guide plate of FIG. 6.

FIG. 11 is an explanatory diagram showing a directivity characteristic of an LED light source.

DESCRIPTION OF PREFERRED EMBODIMENTS

FIG. 1 illustrates a first embodiment of the planar light source according to the present invention, FIG. 1(a) repre-

senting a perspective view of the planar light source **10**, FIG. **1(b)** representing a side view of the same, FIG. **1(c)** representing an enlarged view of portion A in FIG. **1(b)**.

In FIG. **1**, reference number **1** represents LEDs as a light source, **1b** a substrate on which to mount LEDs, **2** a light guide plate, **3** a prism sheet, **6** a reflector plate and **7** a liquid crystal panel. The light guide plate **2** is rectangular in plan view and formed of a light-transmitting resin, such as polycarbonate. **2a** denotes a top surface of the light guide plate **2**, and **2b** a bottom surface. Designated **2c** is a light receiving side surface **2c** facing the LEDs **1**. The bottom surface **2b** is formed with a plurality of asymmetric prisms **2bp**. The asymmetric prisms **2bp** each have a down slope **2bp1** and an up slope **2bp2**. The down slope **2bp1** is so configured that its distance to the top surface **2a** sharply increases as a point of interest on the slope moves away from the light receiving side surface **2c**. The up slope **2bp2** is so configured that its distance to the top surface **2a** moderately decreases.

Denoted **2d** is a chamfered portion formed at an intersection between the light receiving side surface **2c** and the top surface **2a** of the light guide plate **2**. Designated **2e** is another chamfered portion formed at an intersection between the light receiving side surface **2c** and the bottom surface **2b** of the light guide plate **2**. An inclination angle of the chamfered portion **2d** is, for example, roughly 45° as shown in FIG. **1(c)**.

In this construction, when a predetermined amount of electricity is supplied from a power supply not shown to the LEDs **1**, the LEDs **1** illuminate in white or a predetermined color. Of the emitted rays of light from the LEDs **1**, one that has entered the light guide plate **2** through the light receiving side surface **2c** (excluding the chamfered portions **2d**, **2e**), as shown by a dotted line in FIG. **1(b)**, has a smaller refracted angle than the critical angle of the light guide plate **2**, so that, according to the same principle as explained in the conventional case of FIG. **7**, when the ray first reaches the top surface **2a** or bottom surface **2b**, its incident angle on the surface (θ_1 in FIG. **7**) is greater than the critical angle and thus totally reflected. Then, the ray is repetitively reflected between the top surface **2a** and the bottom surface **2b**, as shown by the dotted line in FIG. **1(b)**, with its incident angle decreasing by an inclination angle of the slope (equivalent to α in FIG. **7**) upon each reflection. When the incident angle is less than the critical angle, the ray is refracted and emitted outside. The light ray that has followed a normal path and exited from the top surface **2a** of the light guide plate **2** enters the prism sheet **3**. The ray that has entered the prism sheet **3** is specular-reflected in the prism sheet **3** until it changes its propagation direction to a Z direction. The light traveling in the Z direction is now incident on the liquid crystal panel **7**. Therefore, the light passes through the liquid crystal in an ideal direction, making a clear and vivid image display possible.

As shown in an enlarged view of FIG. **1(c)**, an edge **2d1**, at which the chamfered portion **2d** and the top surface **2a** cross each other, and an edge **2d2**, at which the chamfered portion **2d** and the light receiving side surface **2c** intersect, have intersection angles $\theta d1$ and $\theta d2$ of more than 90° , which ensures a good transferability during the process of molding the light guide plate **2**. So, the surfaces of the edges **2d1**, **2d2** hardly become rough as in the conventional light guide plate **2**. Therefore, at the edges **2d1**, **2d2** a secondary light source as observed in the conventional light guide plate is hardly produced. Also, at the lower chamfered portion **2e** in FIG. **1(b)**, a secondary light source is not easily formed, for the similar reason described above.

Therefore, in the planar light source **10** of the first embodiment, the conspicuous bright lines as observed in the conventional light guide plate can often be avoided.

FIG. **2** is a plan view showing one example of illuminating light produced in the planar light source **10**. In this example, the light guide plate **2** has no conspicuous bright lines over an entire region R, unlike the conventional planar light source in which marked bright lines show up. Further, when a member for restricting the direction of light transmission, such as prism sheet or diffusion plate, is arranged opposite the top surface of the light guide plate **2**, the distinguished bright lines show up in the conventional planar light source. In this invention, however, these bright lines can be eliminated easily.

Next, a second embodiment of the planar light source according to this invention will be described. FIG. **3** illustrates the planar light source of the second embodiment, FIG. **3(a)** representing a side view of the planar light source **20**, FIG. **3(b)** representing an enlarged view of a portion B in FIG. **3(a)**. In FIG. **3**, reference number **2f** denotes a curved portion, arc-shaped in cross section and formed at an intersection between the light receiving side surface **2c** and the top surface **2a** of the light guide plate **2**. Reference number **2g** designates a curved portion, arc-shaped in cross section and formed at an intersection between the light receiving side surface **2c** and the bottom surface **2b** of the light guide plate **2**. In other respects, the construction is almost the same as that of the planar light source **10** of FIG. **1** and thus its detailed explanation is omitted. Since the two curved portions **2f** and **2g** have their surfaces curved moderately, the transferability during the molding of the light guide plate **2** is improved. This contributes to preventing their surfaces from being formed rough as they are in the conventional edge portions, which in turn makes it easy to prevent the formation of a secondary light source. As a result, no conspicuous bright lines observed in the conventional light guide plate show up. In FIG. **3(a)**, a dotted line represents a normal path of a ray emitted from the LEDs **1** and entering the light guide plate **2**.

Next, a third embodiment of the planar light source according to this invention will be described. FIG. **4** is a side view of the planar light source **30** of the third embodiment. The planar light source **30** of the third embodiment is a variation of the first embodiment of FIG. **1**. In FIG. **4**, reference number **2bh** represents a textured reflection surface formed on the bottom surface **2b** of the light guide plate **2** near the lower chamfered portion **2e**. In other respects, the construction is almost the same as that of the planar light source **10** of FIG. **1** and thus its detailed explanation is omitted. The textured reflection surface **2bh** has an irregular pattern of fine, recessed and raised portions. Therefore, some of the rays scattered by the textured reflection surface **2bh** travel directly toward the top surface **2a** and some exit downward. Those scattered rays that have exited from the bottom surface **2b** of the light guide plate **2** are reflected by the reflector plate **6** to reenter the light guide plate **2** and travel toward the top surface **2a**. In addition to the light paths using the asymmetric prisms **2bp**, there are other light paths using the textured reflection surface **2bh**. As a result, light can be emitted upward also from that region of the top surface **2a** of the light guide plate **2** which is close to the light receiving side surface **2c**, thus allowing the illumination area to be extended close to the light receiving side surface **2c**. In the third embodiment, too, the use of the upper and lower chamfered portions **2d**, **2e** can easily prevent the formation of such secondary light sources as are formed at the conventional edge portions of the light guide plate **2**,

thus rendering the bright lines inconspicuous when the planar light source **30** is illuminated.

Next, a fourth embodiment of the planar light source according to this invention will be described. FIG. **5** is a side view showing the planar light source **40** of the fourth embodiment. As shown in FIG. **5**, the light guide plate is formed with a curved portion **2f**, arc-shaped in cross section, at an intersection between the top surface **2a** and the light receiving side surface **2c** of the light guide plate **2**. At an intersection between the bottom surface **2b** and the light receiving side surface **2c**, the light guide plate has a chamfered portion **2e**. In this planar light source **40**, the presence of the curved portion **2f** and the chamfered portion **2e** makes the generation of the secondary light source unlikely because of the principle already explained. Thus, when the planar light source is illuminated, the bright lines do not show up.

In all the embodiments described above, the whole or most of the bottom surface of the light guide plate of the planar light source is formed of asymmetric prisms. The present invention is not limited to this construction. For example, all or most of the bottom reflection surface of the light guide plate may be formed of symmetric prisms or formed with a regular or irregular pattern of recessed and raised portions formed by printing, surface texturing or dot formation. In this case also, the provision of the chamfered portion **2e** and the curved portion **2f** at the upper and lower edges of the light receiving side surface **2c** of the light guide plate **2** can prevent the formation of the secondary light source, eliminating or making less conspicuous the bright lines which would otherwise be formed by the illuminating light.

As described above, the planar light source according to the present invention can make indistinguishable the bright lines, that may be produced during illumination, to prevent a dark-bright fringe pattern from showing up, thereby preventing a possible degradation of liquid crystal display quality.

What is claimed is:

1. A planar light source comprising:

a light guide plate made of a plate-like, light-transmitting material formed with a light emitting surface on a top side thereof and a reflection surface on a bottom side thereof; and

an illuminating light source arranged opposite a light receiving side surface of the light guide plate;

wherein light coming from the illuminating light source into the light receiving side surface of the light guide plate is light-path-transformed by actions of the reflection surface and the light emitting surface of the light guide plate to emit a planar light flux from the light emitting surface;

wherein chamfered portions are provided at an upper end of the light receiving side surface where the light receiving side surface and the light emitting surface of the light guide plate intersect and at a lower end of the light receiving side surface where the light receiving side surface and the reflection surface of the light guide plate intersect, and

wherein the reflection surface of the light guide plate includes a textured reflection surface and asymmetric prisms, which are formed on the reflection surface.

2. A planar light source comprising:

a light guide plate made of plate-like, light-transmitting material formed with a light emitting surface on a top side thereof and a reflection surface on a bottom side thereof; and

an illuminating light source arranged opposite a light receiving side surface of the light guide plate;

wherein light coming from the illuminating light source into the light receiving side surface of the light guide plate is light-path-transformed by actions of the reflection surface and the light emitting surface of the light guide plate to emit a planar light flux from the light emitting surface;

wherein curved portions are provided at an upper end of the light receiving side surface where the light receiving side surface and the light emitting surface of the light guide plate intersect and at a lower end of the light receiving side surface where the light receiving side surface and the reflection surface of the light guide plate intersect, and

wherein the reflection surface of the light guide plate includes a textured reflection surface and asymmetric prisms, which are formed on the reflection surface.

3. A planar light source comprising:

a light guide plate made of a plate-like, light-transmitting material formed with a light emitting surface on a top side thereof and a reflection surface on a bottom side thereof; and

an illuminating light source arranged opposite a light receiving side surface of the light guide plate;

wherein light coming from the illuminating light source into the light receiving side surface of the light guide plate is light-path-transformed by actions of the reflection surface and the light emitting surface of the light guide plate to emit a planar light flux from the light emitting surface;

wherein a chamfered portion is provided either at an upper end of the light receiving side surface where the light receiving side surface and the light emitting surface of the light guide plate intersect or at a lower end of the light receiving side surface where the light receiving side surface and the reflection surface of the light guide plate intersect, and a curved portion is provided at the other end, and

wherein the reflection surface includes a textured reflection surface and asymmetric prisms, which are formed on the reflection surface.

4. A planar light source according to any one of claims **1** to **3**, wherein a member for restricting a direction of light transmission is arranged opposite the light emitting surface of the light guide plate.

5. A planar light source according to claim **4**, wherein the member for restricting the direction of light transmission is a prism sheet.

6. A planar light source according to any one of claims **1** to **3**, wherein the textured reflection surface is formed at an area near the light receiving side surface of the light guide plate, and

wherein the asymmetric prisms are formed at an area remote from the light receiving side surface of the light guide plate.