



US007011367B2

(12) **United States Patent**  
**Riley**

(10) **Patent No.:** **US 7,011,367 B2**  
(45) **Date of Patent:** **Mar. 14, 2006**

(54) **UNIVERSALLY ADJUSTABLE SLIPCOVER FOR DINING ROOM CHAIRS**

(56) **References Cited**

**U.S. PATENT DOCUMENTS**

(75) Inventor: **Paula Riley**, New York, NY (US)  
(73) Assignee: **Prescient Partners, LP**, New York, NY (US)  
(\* ) Notice: Subject to any disclaimer, the term of this patent is extended or adjusted under 35 U.S.C. 154(b) by 119 days.

1,825,909 A *	10/1931	Levi .....	297/224
1,836,302 A *	12/1931	Bloomfield .....	297/229
2,179,805 A *	11/1939	Trubitz .....	297/225
2,344,093 A *	3/1944	Kotowicz .....	297/228.1
2,349,193 A *	5/1944	Pass .....	297/225
2,522,404 A *	9/1950	Siebelist .....	297/229
2,820,510 A *	1/1958	Sugarman .....	297/228
2,937,695 A *	5/1960	Coggin .....	297/227
4,676,549 A *	6/1987	English .....	297/224

\* cited by examiner

(21) Appl. No.: **10/776,301**

*Primary Examiner*—Peter R. Brown

(74) *Attorney, Agent, or Firm*—Notaro & Michalos PC

(22) Filed: **Feb. 11, 2004**

(57) **ABSTRACT**

(65) **Prior Publication Data**  
US 2005/0173953 A1 Aug. 11, 2005

A dining room chair slipcover arrangement has a pair of seat panels to cover each side of a seat while leaving an uncovered area. Each panel extends a full depth of the seat to a point below a front end of the seat. A chasuble covers the uncovered area of the seat and extends from a point below the front end of the seat, across the seat depth, up along a front surface of the back, across the top and down the rear surface of the back. Wrapping parts and connectors extending around the back for holding the chasuble to the chair. A skirt extends around the seat to cover sides of the seat and upper parts of the chair legs.

(51) **Int. Cl.**  
*A47C 31/11* (2006.01)

(52) **U.S. Cl.** ..... **297/228.1**; 297/219.1;  
297/229

(58) **Field of Classification Search** ..... 297/219.1,  
297/225, 228.1, 228.12, 229  
See application file for complete search history.

**18 Claims, 5 Drawing Sheets**

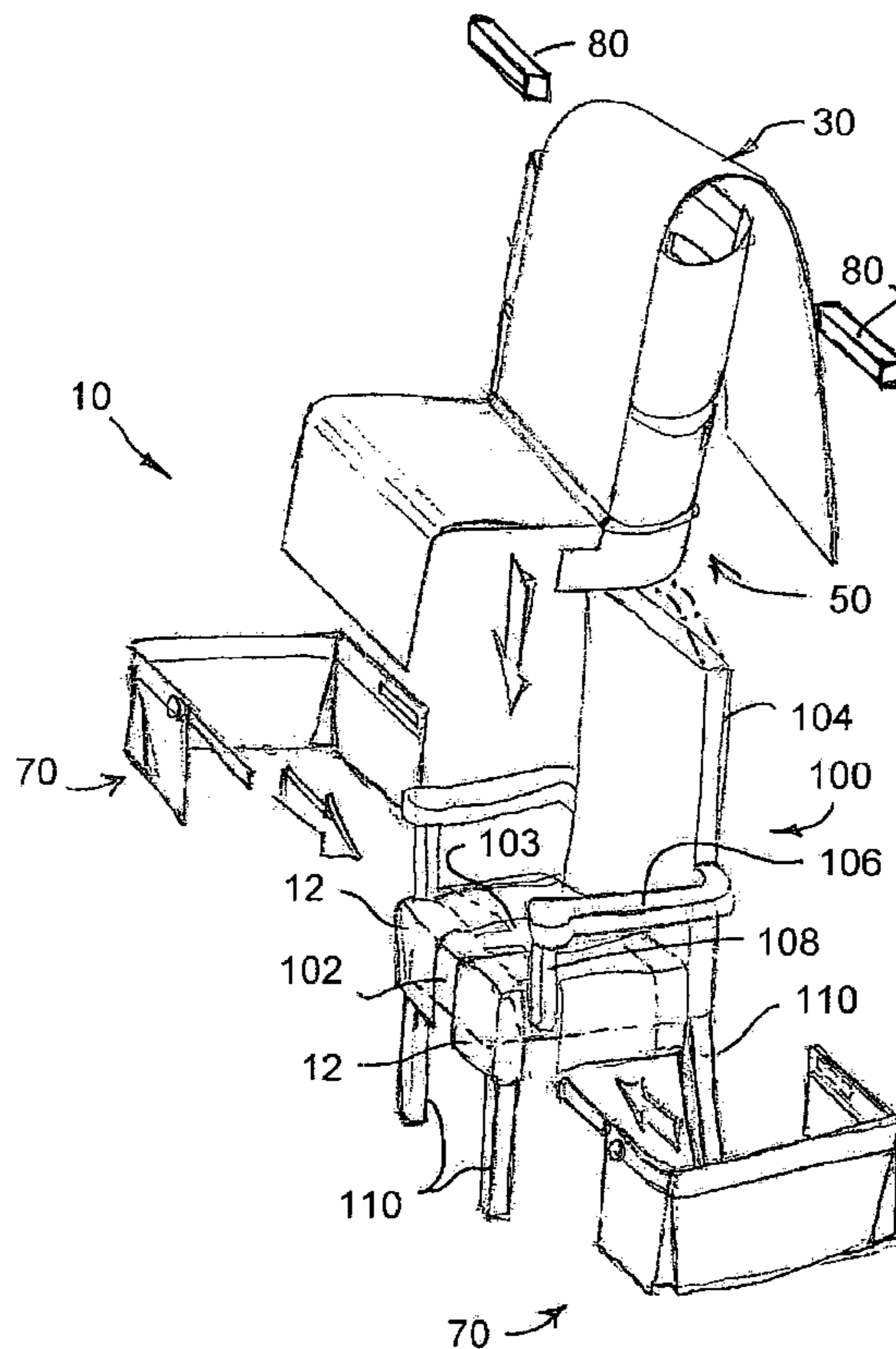
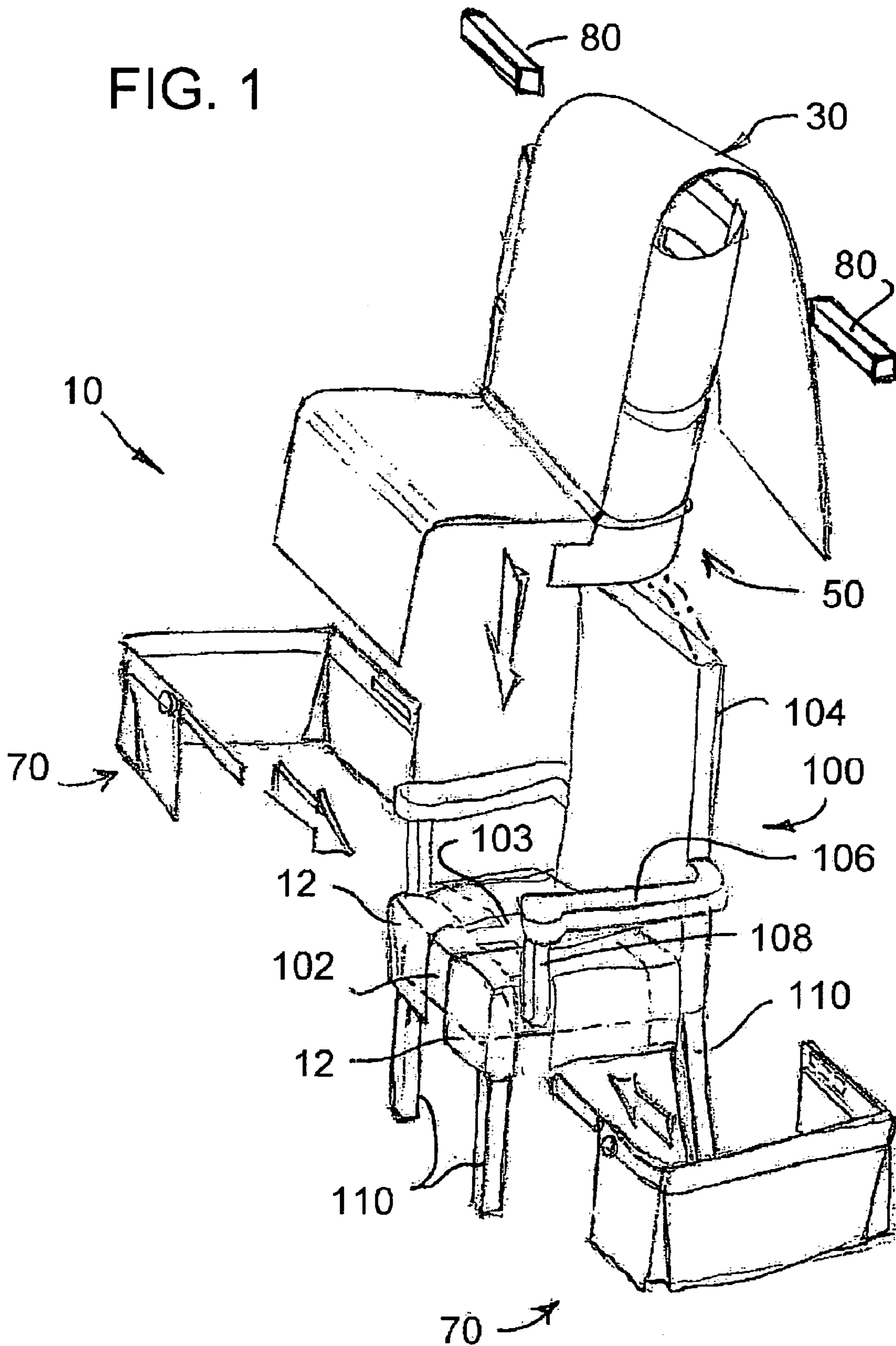

FIG. 1



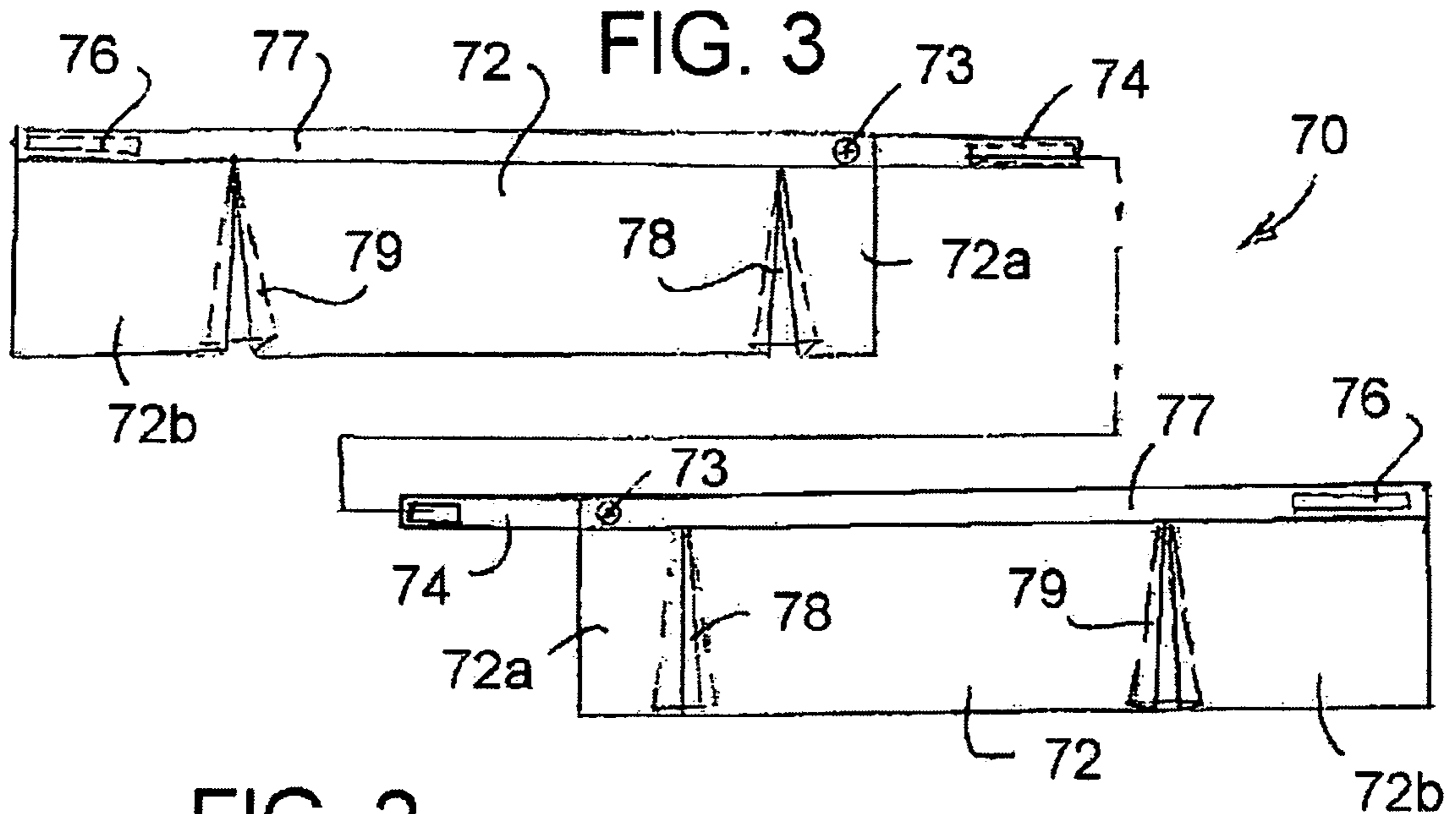
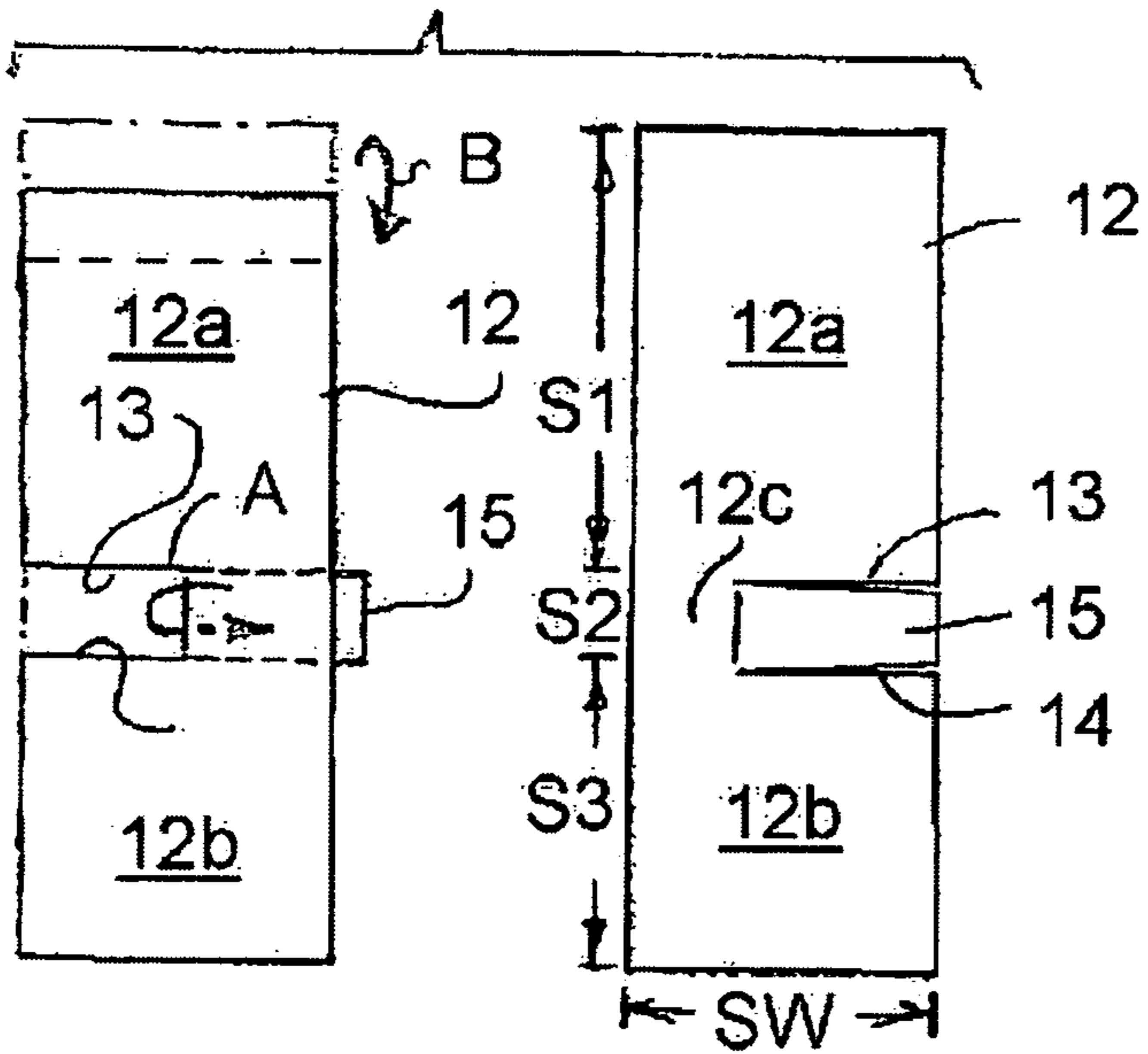

FIG. 2



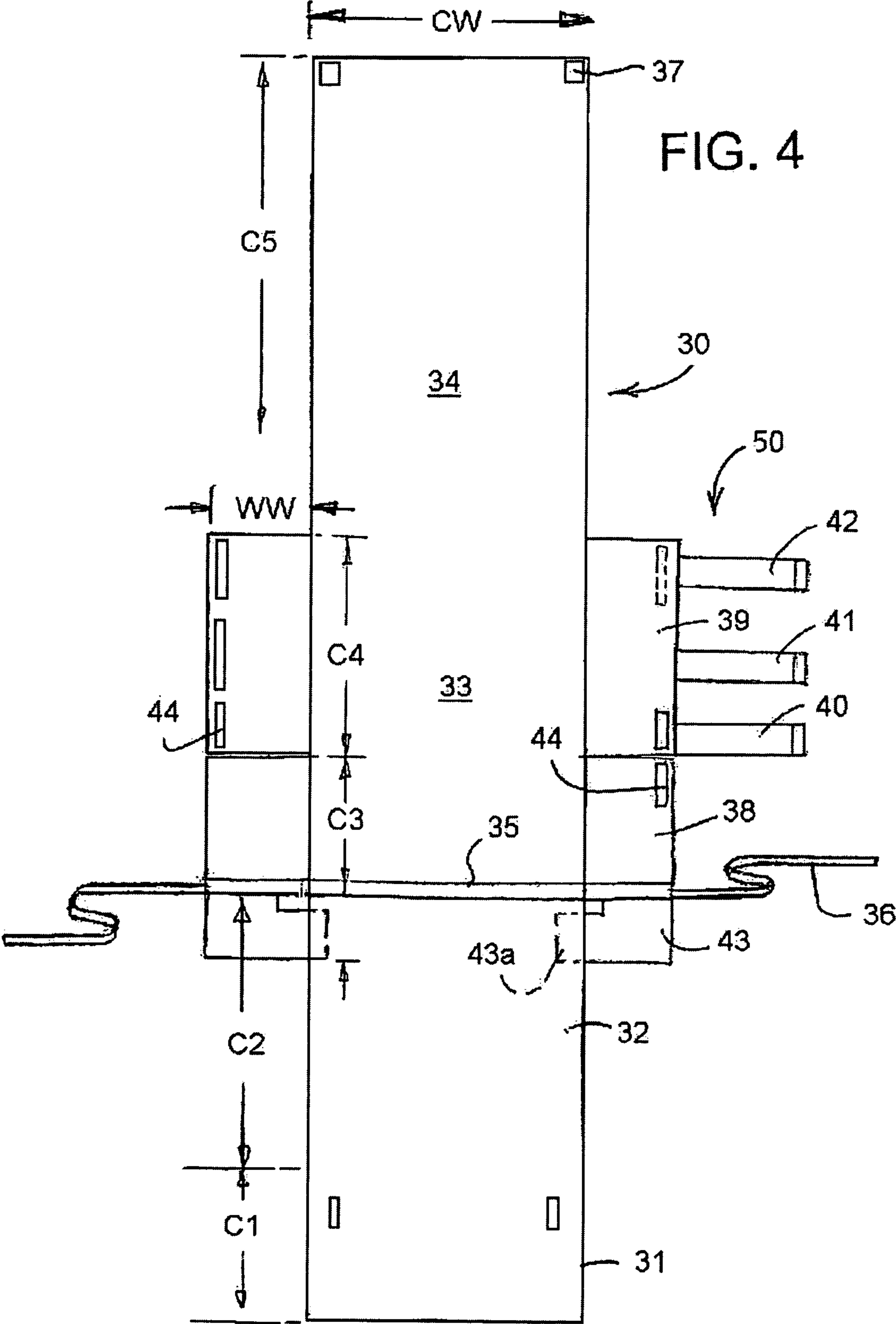

FIG. 5

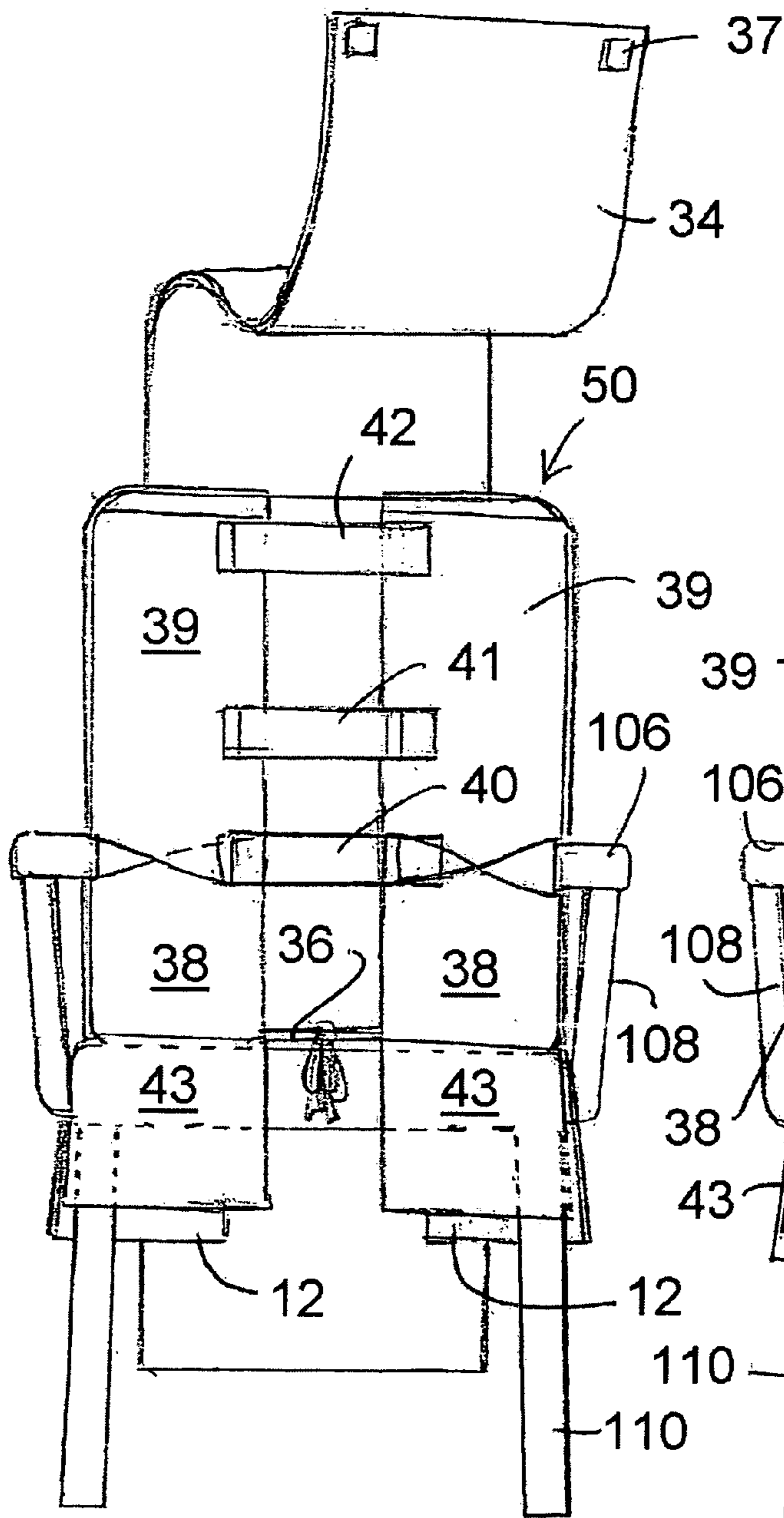

FIG. 6

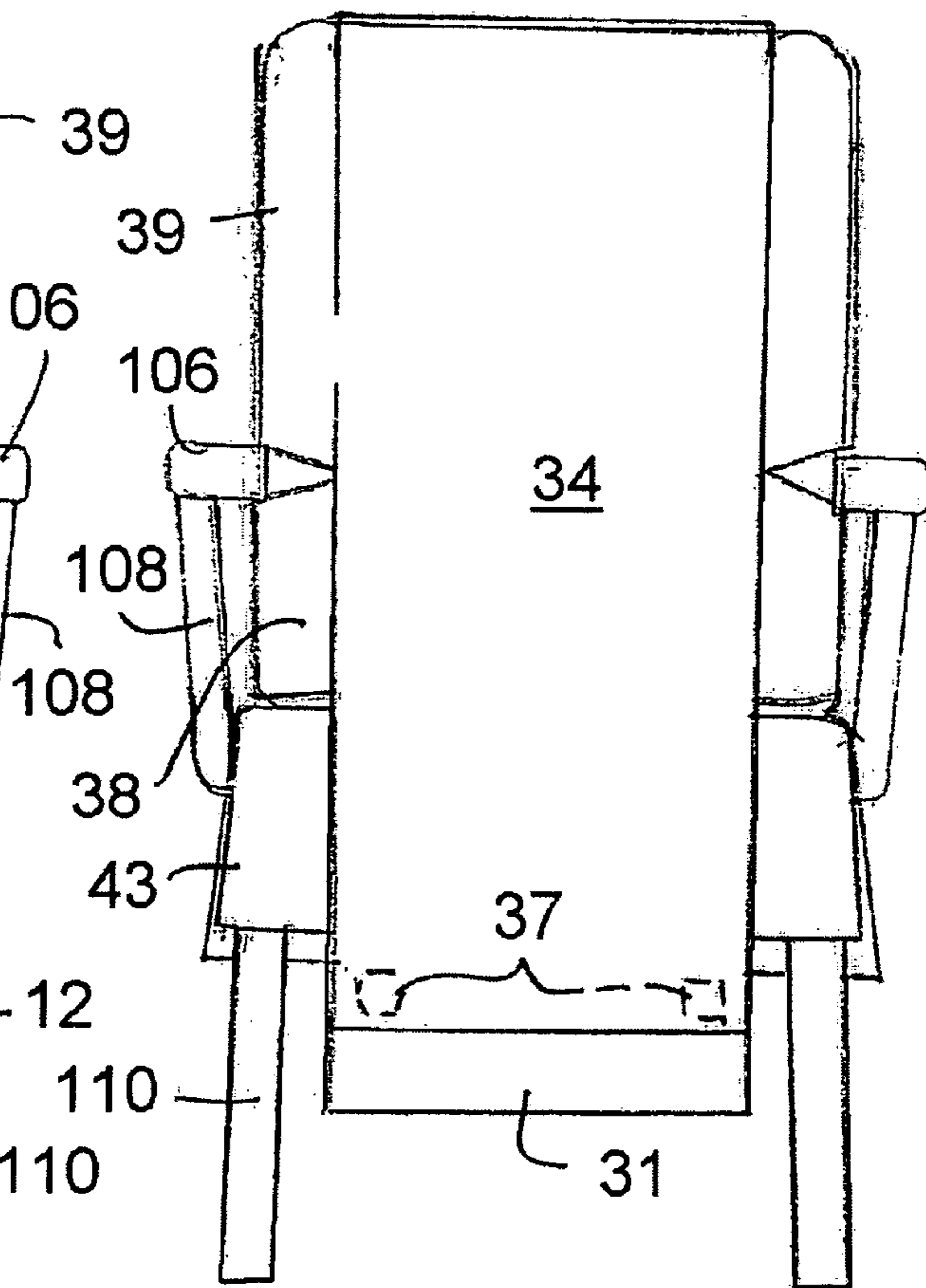

FIG. 7

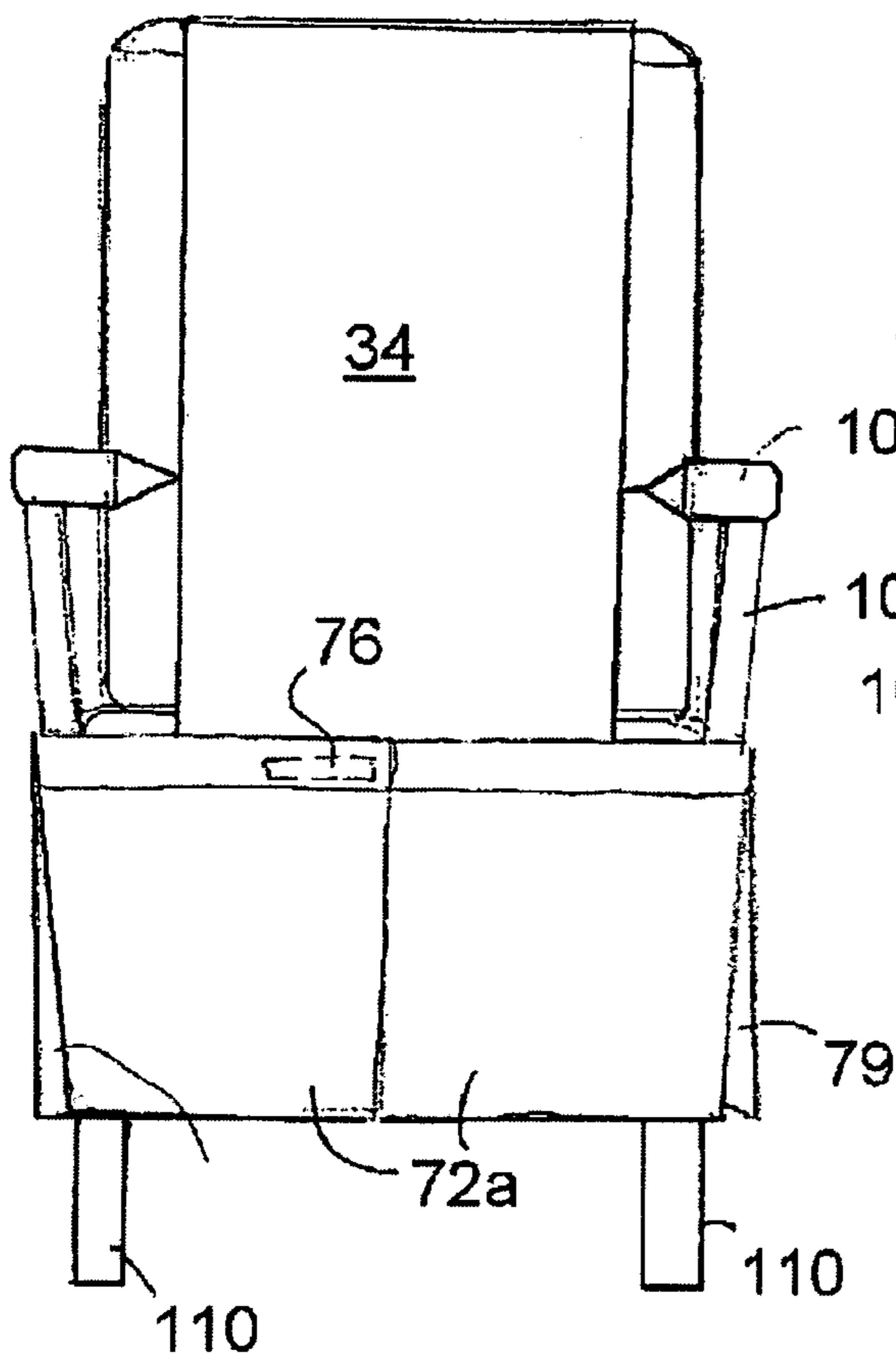
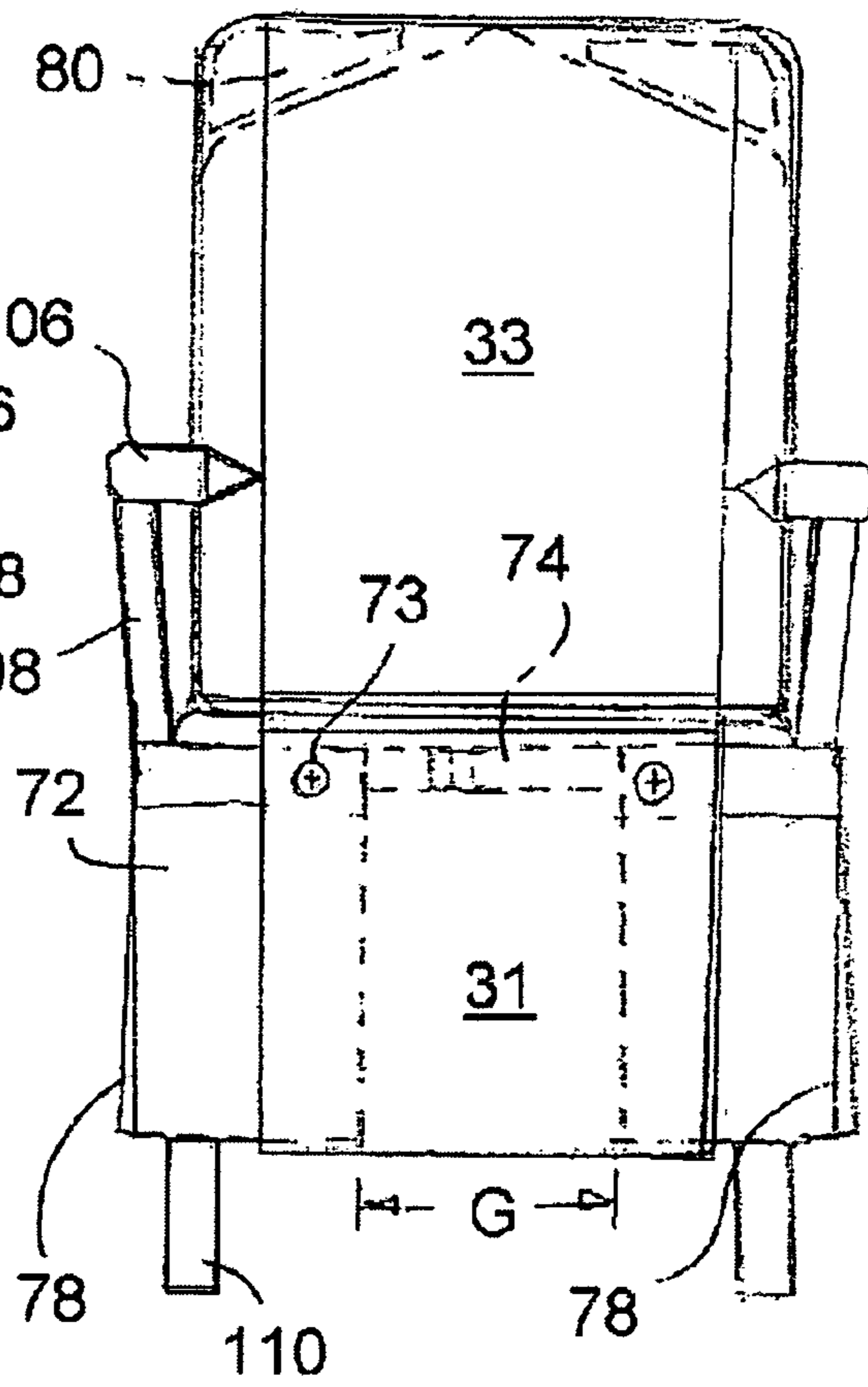

FIG. 8



1

## UNIVERSALLY ADJUSTABLE SLIPCOVER FOR DINING ROOM CHAIRS

### FIELD AND BACKGROUND OF THE INVENTION

The present invention relates generally to the field of slipcovers, and in particular, to a new and useful slipcover for attractively and effectively covering dining room chairs, and more particularly, chairs with arms, and which can cover chairs having a wide range of sizes and shapes, and without the usual baggy unfitted look that is common for known dining room chair covers.

Covers for chairs are known, for example, from U.S. Pat. No. 1,820,104 to Whaley and U.S. Pat. No. 6,354,661 to Moss. Also see U.S. Design Pat. No. D473,090 to Trucchi. To date, however, there has been no effective way of covering a dining room chair, particularly one which has arms. Even the known covers for chairs without arms tend to look baggy and unfitted. This is partly due to the wide range of sizes and shapes that dining room chairs come in.

The inventor here has found that generally dining room chairs have a seat that can be about 19 to 24 inches wide and about 19 to 27 inches deep. The chair back can rise to a height of about 36 to 44 inches from the floor and can be of many varies shapes. The height of the seat from the floor is a fairly predictable dimension of about 16 to 19 inches.

For dining room chairs with arms, the shapes, placements and sizes of the arms are even more varied. Generally, an upper horizontally extending part of each arm has a rear end connected to the back of the chair at about 7 to 9 inches above the seat. Each arm also generally has a vertically extending part at the front, with a low end connected at the side of the chair seat. This second connecting point can be anywhere from a point near the chair back, to a point near the front edge of the seat.

Any effective slipcover for this type of furniture must accommodate all of these variables and more, and the present invention has done so. The slipcover arrangement of the invention is not limited to chairs having arms, but can cover chairs without arms. Also, the slipcover arrangement of the invention can cover chairs having dimensions that are outside the ranges observed above.

### SUMMARY OF THE INVENTION

It is an object of the present invention to provide a slipcover for a dining room chair which closely fits all parts of the chair regardless of its dimensions or shape, and whether the chair has arms or not.

Accordingly, another object of the invention is to provide a dining room chair slipcover arrangement for a dining room chair having a seat with a seat width and a seat depth, a back rising from a rear end of the seat and having a back width and a back height, and at least one, but usually four legs for maintaining the seat at a seat height, which arrangement comprises a pair of seat panels adapted to cover at least portions of each side of the seat while leaving an uncovered area on the seat between the seat panels in the direction of the seat width. Each seat panel has a length for extending a full seat depth from the back of a chair to be covered, to a point below a front end of the seat to be covered, a chasuble having a width to cover the uncovered area of the seat to be covered, and a total length for extending from a point below the front end of the seat to be covered, across the seat depth, up along a front surface of the back of the chair to be covered, across a top of the back and at least down part of

2

a rear surface of the back and wrapping means connected to the chasuble for extending around at least part of the back for holding the chasuble over the seat panels and to the chair to be covered.

The seat panels each have a width of less than a minimum seat width for dining room chairs, and a length of more than a maximum seat depth for dining room chairs. Excess fabric is folded under at the rear end of the seat and draped down the sides and front of the seat. For covering chairs with arms, each seat panel includes at least one, but preferably two slits for receiving a portion of a dining room chair arm connected to the seat to be covered. The fabric between the slits is folded under the panel to make room for the arm.

The invention also may include a skirt for engaging around the seat to be covered and for extending from the seat down a portion of the seat height.

The various features of novelty which characterize the invention are pointed out with particularity in the claims annexed to and forming a part of this disclosure. For a better understanding of the invention, its operating advantages and specific objects attained by its uses, reference is made to the accompanying drawings and descriptive matter in which a preferred embodiment of the invention is illustrated.

### BRIEF DESCRIPTION OF THE DRAWINGS

In the drawings:

FIG. 1 is an exploded, perspective view of the dining room chair slipcover arrangement of the present invention with a dining room arm chair to be covered;

FIG. 2 is a top plan view of a pair of side panels of the arrangement;

FIG. 3 is a side elevational view of a skirt of the arrangement;

FIG. 4 is a top plan view of a chasuble of the arrangement;

FIG. 5 is a rear elevational view of the arm chair with the arrangement partly engaged;

FIG. 6 is a view similar to FIG. 5 of a further position of the arrangement on the arm chair;

FIG. 7 is a view similar to FIG. 5 of a still further position of the arrangement on the arm chair; and

FIG. 8 is a view front elevational view of the invention fully covering the arm chair.

### DESCRIPTION OF THE PREFERRED EMBODIMENTS

Referring now to the drawings, in which like reference numerals are used to refer to the same or similar elements, FIG. 1 illustrates a slipcover arrangement **10** for a dining room chair **100** that is universally adjustable to closely, attractively and securely cover a wide variety of dining room chair types, sizes and shapes, and importantly, accommodate chairs with arms as well as those without arms.

Chair **100** has a seat **102** with a seat width and a seat depth, a back **104** rising from a rear end of the seat **102** and having a back width and a back height, and at least one, but usually four legs **110** for maintaining the seat **102** at a seat height above the floor.

While appreciating the wide range of sizes and shapes of the chair seat and back, and also the varied possible placements of the chair arms, if arms are present, the slipcover arrangement of the invention comprises a pair of seat panels **12** made of fabric or other appropriate flexible material and adapted to cover at least portions of each side of the seat **102**, while leaving an uncovered area **103** on the seat **102**, between the seat panels **12** in the direction of the seat width.

Each seat panel **12** has a length for extending a full seat depth from a back **104** of the chair **100**, to a point below a front end of the seat **102** as shown in FIG. 1.

As also shown in FIG. 1, the arrangement includes a chasuble **30** of fabric or other appropriate material, having a width sufficient to fully cover the uncovered area **103** of the seat and parts of the side panels as well. The chasuble has a total length sufficient for extending from a point below the front end of the seat **102** (as shown in FIG. 5), across the seat depth, up along a front surface of the back **104** of the chair **100**, across a top of the back and at least partly down a rear surface of the back (as shown in FIG. 6).

Wrapping means generally designated **50** and to be described in detail later in connection with a preferred embodiment of the invention, are connected to the chasuble **30** for extending around at least part of the back **104** for holding the chasuble **30** over the seat panels **12, 12**, and to the chair **100** to be covered.

FIG. 1 also illustrates a pair of shoulders **80** which are made of foam rubber or other flexible resilient material that can be compressed. These shoulders are used as fillers in cases where the back **104** of chair **100** has a peaked or raised center shown in phantom line. For this type of chair, shoulders **80** are placed on the top edge of chair back **104**, on either side of the central peak, and the chasuble **30** is wrapped over the chair back peak and shoulders to create a smooth, generally straight horizontal covering for the top edge of the chair back **104**.

With reference to FIG. 2, each seat panel **12** has a width SW of about 13 inches, or within the range of about 6 to 19 inches, but in any case, less than about the minimum seat width for dining room chairs. Each panel has a length of about 30 inches, or within the range of about 20 to 40 inches, but in any case, more than about the maximum seat depth for dining room chairs. Each seat panel also includes at least one slit, but preferable two spaced apart slits **13, 14**. Slits **13, 14** define a fabric portion **15** there-between which is folded under the rest of the panel in the direction of arrow A, as shown for the left panel **12** in FIG. 2, for receiving a front portion **108** of a dining room chair arm **106**, that is connected to the seat **102** as shown in FIGS. 1 and 2. Slits **13** and **14** extend from left and right edges of the respective left and right side panels **12, 12** to accommodate the chair arm **106** on each side of chair **100**. Each slit **13, 14** and therefore the fabric portion **15**, is about 6½ inches long to allow sufficient fabric to drape the sides of the seat **102**.

Each side panel **12** has a rear portion **12a** for covering the rear part of the side of the seat that is between the chair back **104** and the arm portion **108**, with a length S1 of about 17 inches. This insures that all of the rear parts of the seat side behind the is arm is covered, even for the deepest seats. For less deep seats, rear portion **12a** of the side panel **12** is folded under in the direction of arrow B in FIG. 2. A bridge portion **12c** of each side panel between the slits **13** and **14**, has a length S2 of about 2¾ inches to accommodate the arm portion **108**. Front portion **12b** of each side panel **12** has a length S3 of about 9½ to cover each front side part of the seat and leave enough fabric to drape down the front of the seat **102**. The width SW of each panel is sufficient so that at least some of each side panel drapes down the sides of the seat after the side panel has been placed with the arm portion **108** in the deepest part of the space left by the folded back portion **15**. FIG. 1 shows the placed, folded and draped positions for the side panels **12**.

A skirt **70**, shown in two parts in FIGS. 1 and 3, is also provided for engaging around the seat **102** and for extending from the top of the seat, down the sides of the seat and

further down a portion of the seat height to partly cover the legs **110**. In the preferred embodiment of the invention, the skirt **70** defines a front gap G in FIG. 8, that is covered by a jumper portion of the chasuble **30** to be described later. In the alternative, the jumper portion of the chasuble is behind the skirt at the front of the chair so that the gap G is visible. For this embodiment of the invention, the edges of skirt **70** on either side of gap G are finished.

Returning to FIG. 3, the skirt **70** preferably comprises a pair of skirt portions **72**, with a pair of front connectors **74** for connecting front parts **72a** of the skirt portions to each other to form the gap G of FIG. 8. These front portions **72a** of skirt **70** are either to be partly covered by the jumper portion as shown in FIG. 8, or they extend over the jumper portion. The skirt portions **72** also include a pair of rear connectors **76** for connecting rear parts **72b** of the skirt portions to each other so that the skirt can be wrapped around the seat and tightly held in place as shown in FIGS. 7 and 8.

The width of gap G can vary depending on the width of the chair to be covered. This is done in the embodiment illustrated by providing the connectors **74** to be in the form of a pair of bands or ribbons each extending from an inner front end of the respective skirt portion **72**. Each band has a length of mating hook-and-loop fastener tape, such as the VELCRO (a trademark) brand of fastener, or button/button-hole combinations, or the like. The bands of the connectors **74** are made to overlap by a selected amount and the tapes are mated to hold the front parts of the skirt portions together. Each skirt portion **72** includes a box pleat or shirring of other interruption **78** at a location where the front leg will be to help frame and wrap the chair leg. In likewise fashion, each skirt portion **72** also includes a rear interruption **79** for framing or wrapping each rear leg. See FIGS. 7 and 8 as well.

Rather than spaced pleats **78, 79**, each skirt portion can be shirred like a flounce along its entire length to attractively wrap the seat and legs.

The skirt portions **72** are each about 17 inches high and long enough to reach around any chair, e.g. about 46 inches, understanding that the gap G allows the combined length of the skirt portions to be less than the total circumference of a large dining room chair. Each skirt portion **72** also has an upper border **77** for the connectors **74** and **76** and from which the pleats or shirrings extend. A button or other fastener **73** is provided at the inner front end of each border for a purpose to be explained later in connection with the chasuble **30**.

Turning now to FIG. 4, the chasuble **30** comprises a central body that has a width CW of about 17 inches or within the range of about 14 to 20 inches wide and a total length of about 95 inches or within the range of about 80 to 110 inches. The central body includes a jumper portion **31** for covering a front of the chair, from the front end of the seat down to the point below the front end of the seat shown in FIG. 8. Jumper portion **31** has a preferred length C1 of about 18 inches, a seat portion **32** of length C2 of about 26 inches for extending across the seat depth, a first back portion **33** of length C3 plus C4 of about 26 inches for extending up along the front surface of the back of the chair and across the top of the back, and a second back portion **34** of length C5 of about 31 inches for extending down the rear surface of the back as shown in FIG. 6. A pair of weights **37** can be attached to the inner surface of the second back portion **34** to help smooth this part of the chasuble at the rear surface of the chair back.



## 5

The chasuble **30** also includes a waist **35** extending near a junction between the seat portion **32** and the first back portion **33**, which contains a fabric tunnel that receives a wrapping band **36** in the form of an elastic cord or ribbon. Waist **35** is placed at the rear end of the seat, at the base of the chair back, and the band **36** wraps around the chair back and is tied, hook-and-loop fastened or otherwise connected as shown in FIG. 5, for securing the chasuble to the back of the chair.

The wrapping means **50** also preferably include pairs of side wings **38** and **39** extending from opposite sides of the first back portion **33** for wrapping around the back of the chair, and at least one connector, but preferably three connecting tabs **40**, **41** and **42** for connecting, by hook-and-loop tapes or other fasteners, the wings to each other at the rear surface of the back as shown in FIG. 5. One end of the lower tabs **40** and **41** can be permanently secured, e.g. by sewing to its wing, while the other end is removably connected to the other wing at a mating hook-and-loop pair. Since the dining room chair **100** to be covered can have a back **104** of widely different heights, the top connecting tab **42** should be detachably connected to both upper wings **39** and with long hook-and-loop tabs for a large range of vertical adjustment. Alternatively, one tall panel or tab of stretch material with opposite vertical fasteners can replace the three tabs **40**, **41** and **42**. This panel can span the space between the wings **38** and **39** and mate with vertical fasteners on the outer surface of the wings to connect the wings to each other.

Any extra fabric of the first back portion **33** and the wrapped upper wings **42** at the top of the chair back, are simple folded rearwardly behind the chair and are covered by the second back portion **34** which is allowed to drape down over the connected wrapping means as seen by comparing FIG. 5, with the second back portion **34** still raised, to FIG. 6, with the second back portion **34** hanging down over the rear surface of the chair back. FIG. 8 also illustrates in phantom and dotted lines how the compressible shoulders **80** are squeezed on opposite sides of the chair back peak (if present) and under the chasuble that is wrapped there-over.

The lower wings **38** have a length **C3** of about 7 inches to be under the point of connection of the chair arms **106** to the chair back **104**. The upper wings **39** wrapping around an upper part of the back and the lower wings **38** engage around a lower part of the back so that the arm of the chair is accommodated between the upper and lower wings as shown in FIGS. 5-8.

The chasuble **30** also includes a corner portion **43**, connected to, and extending downwardly from each lower wing **38** for extending around the rear corners of the seat and rear legs.

The upper and lower wings and the corner portions all have a width **WW** of about 9 inches, while the length **C4** of the upper wings **39** are about 14 inches each. Each corner portion **43** also includes an overlapping part **43a** that extends under the draped side panels to properly cover the rear corners of the seats and rear legs. Also, hook-and-loop tapes **44** at overlapping surfaces of the upper and lower wings **38,39** as shown in FIG. 5, connect these overlapping parts to each other and help to closely wrap the rear ends of the arms **106**.

The second back portion **34** may also be provided with a loop or tunnel (not shown) to receive one or both the wings **38** and/or **39** in the case where the chair back **104** is curved. This will help pull the second back portion **34** against the curved chair back.

When used on a chair with no arms, the inner edges of seat panels **12** and **12** may be fix to, i.e. sewn to, the outer edges

## 6

of the seat portion **32** of chasuble **30** and no slits **13** or **14** are needed since the widths of the seat panels **12** will accommodate any chair seat width and no arms need be accommodated.

While a specific embodiment of the invention has been shown and described in detail to illustrate the application of the principles of the invention, it will be understood that the invention may be embodied otherwise without departing from such principles.

What is claimed is:

1. A slipcover arrangement for a dining room chair having a seat with a seat width and a seat depth, a back rising from a rear end of the seat and having a back width and a back height, and at least one leg for maintaining the seat at a seat height, the arrangement comprising:

a pair of seat panels adapted to cover at least portions of each side of a seat to be covered while leaving an uncovered area on the seat between the seat panels in the direction of the seat width, each seat panel having a length for extending a full seat depth from the back of a chair to be covered, to a point below a front end of the seat to be covered;

a chasuble having a width to cover the uncovered area of the seat to be covered, and a total length for extending from a point below the front end of the seat to be covered, across the seat depth, up along a front surface of the back of the chair to be covered, across a top of the back and at least down part of a rear surface of the back;

wrapping means connected to the chasuble for extending around at least part of the back for holding the chasuble over the seat panels and to the chair to be covered; and a skirt for engaging around the seat to be covered and for extending from the seat down a portion of the seat height, the skirt defining a front gap that is covered or spanned by a jumper portion of the chasuble.

2. The slipcover of claim 1, wherein each seat panel has a width of less than the seat width, and a length of more than the seat depth.

3. The slipcover of claim 1, wherein each seat panel includes at least one slit for receiving a portion of a dining room chair arm connected to the seat to be covered.

4. The slipcover of claim 1, the skirt comprising a pair of skirt portions with a pair of front connectors for connecting front parts of the skirt portions to each other to form the gap, and a pair of rear connectors for connecting rear parts of the skirt portions.

5. The slipcover of claim 1, wherein the chasuble comprises the jumper portion for covering a front of the chair to be covered from the front end of the seat down to the point below the front end of the seat to be covered, a seat portion for extending across the seat depth, a first back portion for extending up along the front surface of the back of the chair to be covered and across the top of the back, and a second back portion for extending down a rear surface of the back.

6. The slipcover of claim 5, wherein the chasuble has a waist extending near a junction between the seat portion and the first back portion, the wrapping means includes a band at the waist for securing the waist of the chasuble to the back of the chair to be covered.

7. The slipcover of claim 5, wherein the chasuble includes a pair of side wings extending from opposite sides of the first back portion for wrapping around the back of the chair to be covered, and at least one connector for connected the wings to each other at the rear surface of the back, the second back portion being adapted to cover the connected wings at the rear surface of the back.

7

8. The slipcover of claim 7, wherein each side wing comprises an upper wing for wrapping around an upper part of the back and a lower wing for engaging around a lower part of the back so that an arm of the chair to be covered which is connected to the back is accommodated between the upper and lower wings, and connectors for connecting the upper wings to each other and for connecting the lower wings to each other.

9. The slipcover of claim 8, wherein the chasuble includes a corner portion connected to, and extending downwardly from each lower wing for extending around rear corners of the seat to be covered.

10. The slipcover of claim 1, wherein the wrapping means comprise a plurality of elastic tabs for connecting portions of the chasuble that are wrapped around to the rear surface of the back, the chasuble being sufficiently long so that a portion of the chasuble covers the tabs at the rear surface of the back.

11. The slipcover of claim 1, including connectors for connecting the jumper portion of the chasuble to the skirt on opposite sides of the gap.

12. The slipcover of claim 1, wherein the pair of seat panels are fixed to opposite sides of a seat portion of the chasuble.

13. A slipcover arrangement for a dining room chair having a seat with a seat width and a seat depth, a back rising from a rear end of the seat and having a back width and a back height, and at least one leg for maintaining the seat at a seat height, the arrangement comprising:

a pair of seat panels adapted to cover at least portions of each side of a seat to be covered while leaving an uncovered area on the seat between the seat panels in the direction of the seat width, each seat panel having a length for extending a full seat depth from the back of a chair to be covered, to a point below a front end of the seat to be covered;

a chasuble having a width to cover the uncovered area of the seat to be covered, and a total length for extending from a point below the front end of the seat to be covered, across the seat depth, up along a front surface of the back of the chair to be covered, across a top of the back and down a rear surface of the back;

wrapping means connected to the chasuble for extending around at least part of the back for holding the chasuble over the seat panels and to the chair to be covered;

each seat panel have a width of less than the seat width, and a length of more than the seat depth, each seat panel includes at least one slit for receiving a portion of a dining room chair arm connected to the seat to be covered; and

8

a skirt for engaging around the seat to be covered and for extending from the seat down a portion of the seat for holding the chasuble and the side panels to the chair, the skirt defining a front gap that is covered by a jumper portion of the chasuble.

14. The slipcover of claim 13, wherein the skirt comprises a pair of skirt portions with a pair of front connectors for connecting front parts of the skirt portions to each other to form the gap covered by the jumper portion and a pair of rear connectors for connecting rear parts of the skirt portions to each other.

15. The slipcover of claim 14, wherein the chasuble comprises the jumper portion for covering a front of the chair to be covered from the front end of the seat down to the point below the front end of the seat to be covered, a seat portion for extending across the seat depth, a first back portion for extending up along the front surface of the back of the chair to be covered and across the top of the back, and a second back portion for extending down a rear surface of the back.

16. The slipcover of claim 15, wherein the chasuble has a waist extending near a junction between the seat portion and the first back portion, the wrapping means include a band at the waist for securing the waist of the chasuble to the back of the chair to be covered.

17. The slipcover of claim 16, wherein the chasuble includes a pair of side wings extending from opposite sides of the first back portion for wrapping around the back of the chair to be covered, and at least one connector for connecting the wings to each other at the rear surface of the back, the second back portion being adapted to cover the connected wings at the rear surface of the back.

18. The slipcover of claim 17, wherein each side wing comprises an upper wing for wrapping around an upper part of the back and a lower wing for engaging around a lower part of the back, so that an arm of the chair to be covered which is connected to the back is accommodated between the upper and lower wings, and connectors for connecting the upper wings to each other and for connecting the lower wings to each other, the chasuble including a corner portion connected to, and extending downwardly from each lower wing for extending around rear corners of the seat to be covered.

\* \* \* \* \*