

US006995959B2

(12) **United States Patent**
Ju et al.

(10) **Patent No.:** **US 6,995,959 B2**
(45) **Date of Patent:** **Feb. 7, 2006**

(54) **INTEGRATED SPIN VALVE HEAD**

(75) Inventors: **Kochan Ju**, Fremont, CA (US); **Cheng Horng**, San Jose, CA (US); **Youfeng Zheng**, San Jose, CA (US); **Simon Liao**, Fremont, CA (US); **Jei-Wei Chang**, Cupertino, CA (US)

(73) Assignee: **Headway Technologies, Inc.**, Milpitas, CA (US)

(*) Notice: Subject to any disclaimer, the term of this patent is extended or adjusted under 35 U.S.C. 154(b) by 4 days.

(21) Appl. No.: **11/011,957**

(22) Filed: **Dec. 14, 2004**

(65) **Prior Publication Data**

US 2005/0094321 A1 May 5, 2005

Related U.S. Application Data

(62) Division of application No. 09/696,134, filed on Oct. 26, 2000, now Pat. No. 6,885,527.

(51) **Int. Cl.**

G11B 5/127 (2006.01)

G11B 5/33 (2006.01)

(52) **U.S. Cl.** **360/324.1**

(58) **Field of Classification Search** 360/324,

360/324.1, 324.11, 324.2; 29/603.01

See application file for complete search history.

(56) **References Cited**

U.S. PATENT DOCUMENTS

4,340,088 A 7/1982 Geisow

4,411,316 A	10/1983	Carmody	
5,564,675 A	10/1996	Hill, Jr. et al.	
5,608,593 A	3/1997	Kim et al.	360/113
5,668,688 A	9/1997	Dykes et al.	360/113
5,777,542 A	7/1998	Ohsawa et al.	338/32 R
5,828,527 A	10/1998	Takada et al.	360/113
5,978,182 A	11/1999	Kanai et al.	360/113
5,999,379 A	12/1999	Hsiao et al.	360/113
6,385,017 B1 *	5/2002	Min et al.	360/324.12
6,885,527 B1 *	4/2005	Ju et al.	360/324.1
2003/0155131 A1	8/2003	Vick, Jr.	

OTHER PUBLICATIONS

Baker Oil Tools, "Baker 'M' Series Non-Elastomeric Valves" informational publication, undated.

* cited by examiner

Primary Examiner—David D. Davis

(74) *Attorney, Agent, or Firm*—George O. Saile; Stephen B. Ackerman

(57) **ABSTRACT**

Currently, the shield-to-shield separation of a spin valve head cannot be below about 800 Å, mainly due to sensor-to-lead shorting problems. This problem has now been overcome by inserting a high permeability, high resistivity, thin film shield on the top or bottom (or both) sides of the spin valve sensor. A permeability greater than about 500 is required together with a resistivity about 5 times greater than that of the free layer and an $M_r T$ value for the thin film shield that is 4 times greater than that of the free layer. Five embodiments of the invention are described.

10 Claims, 7 Drawing Sheets

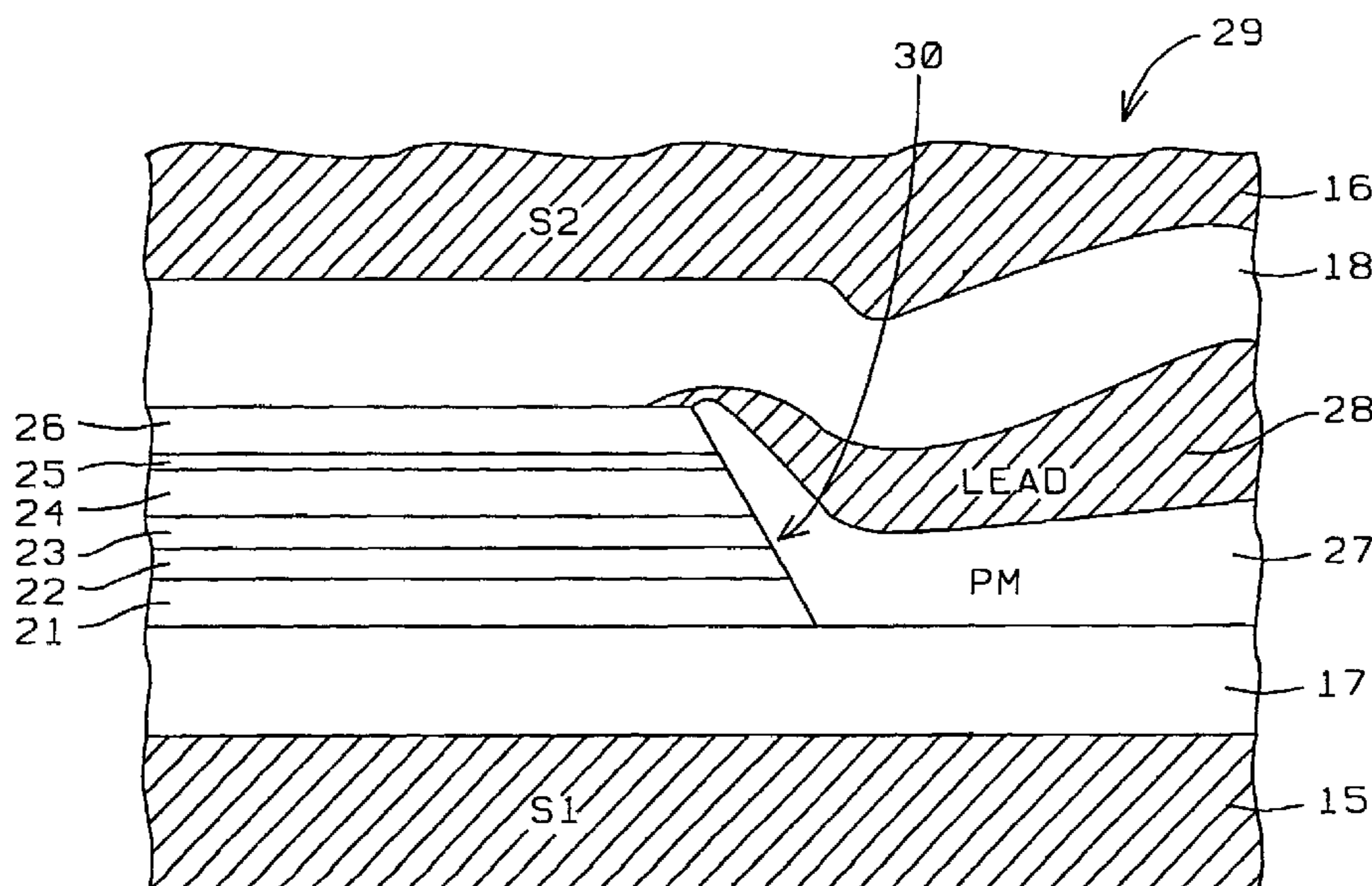

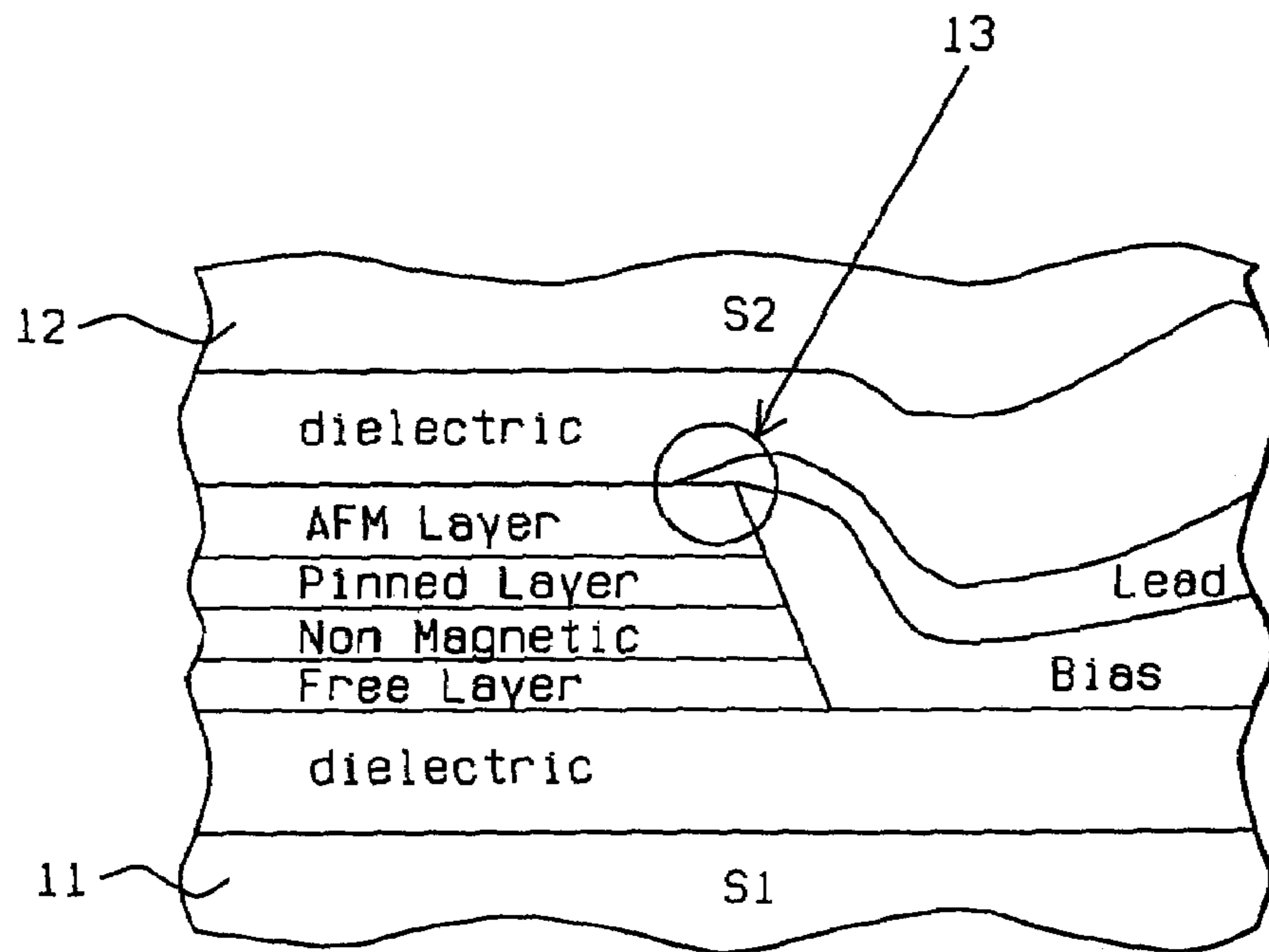

FIG. 1 - Prior Art

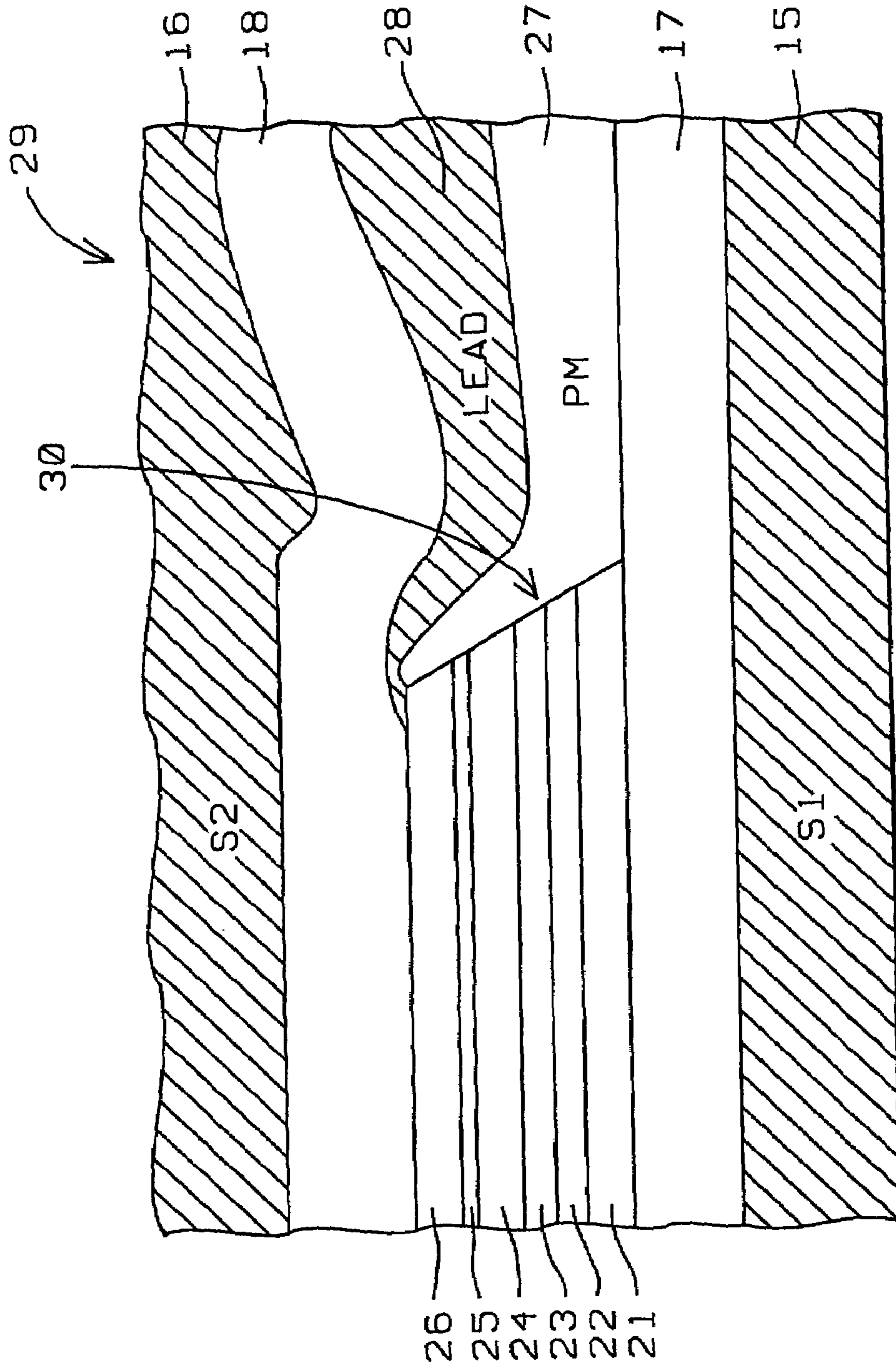

FIG. 2

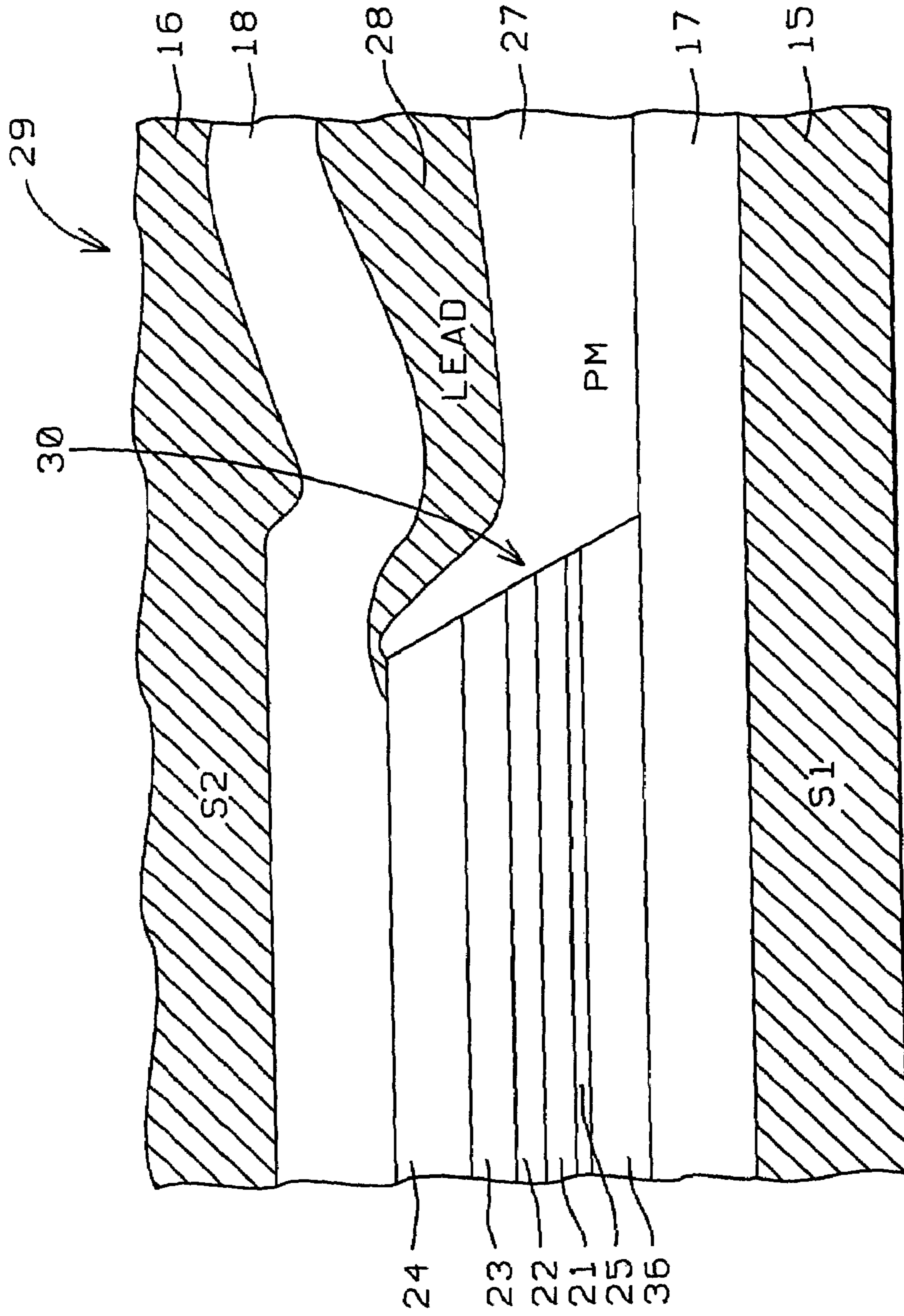

FIG. 3

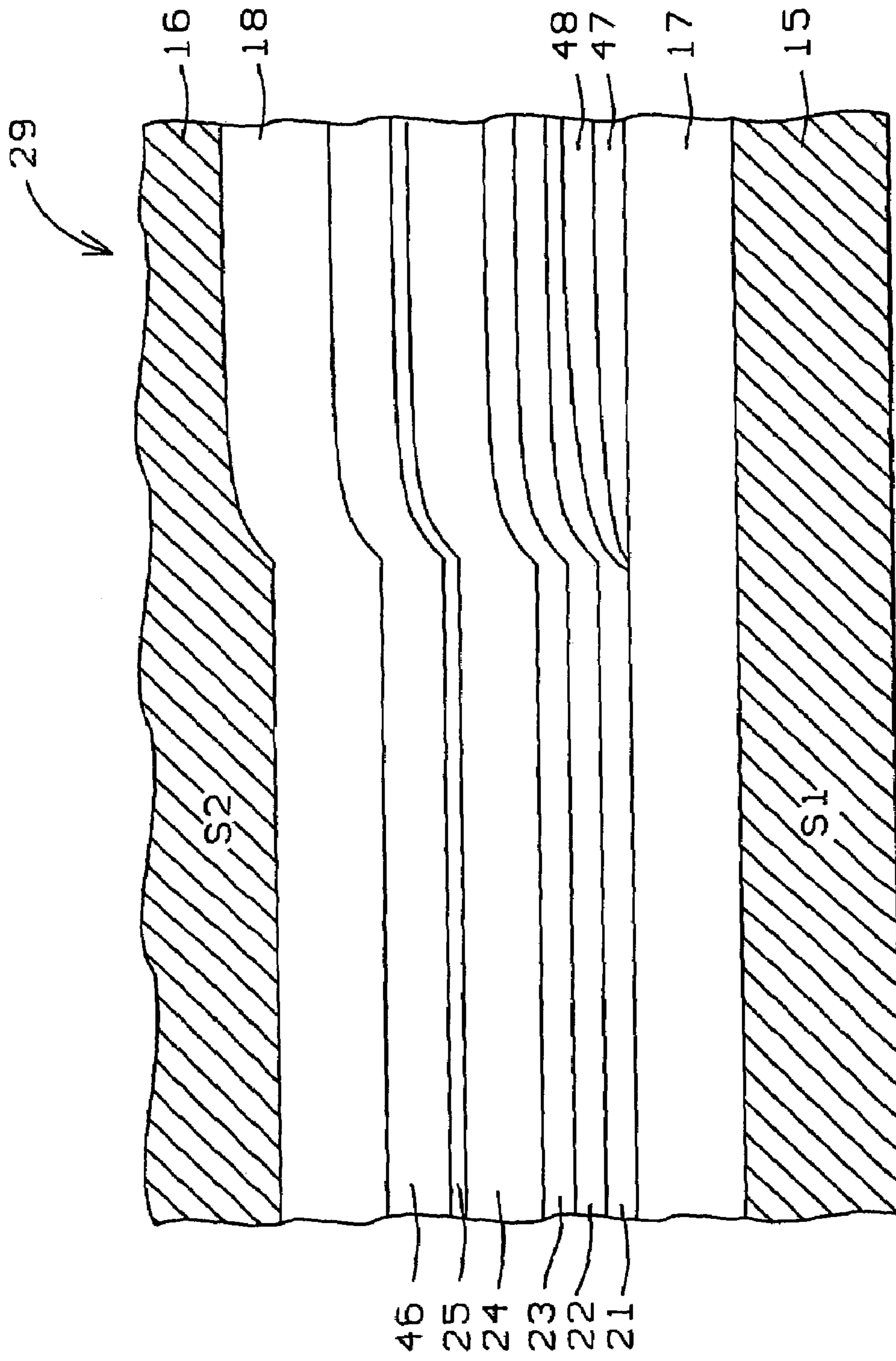

FIG. 4

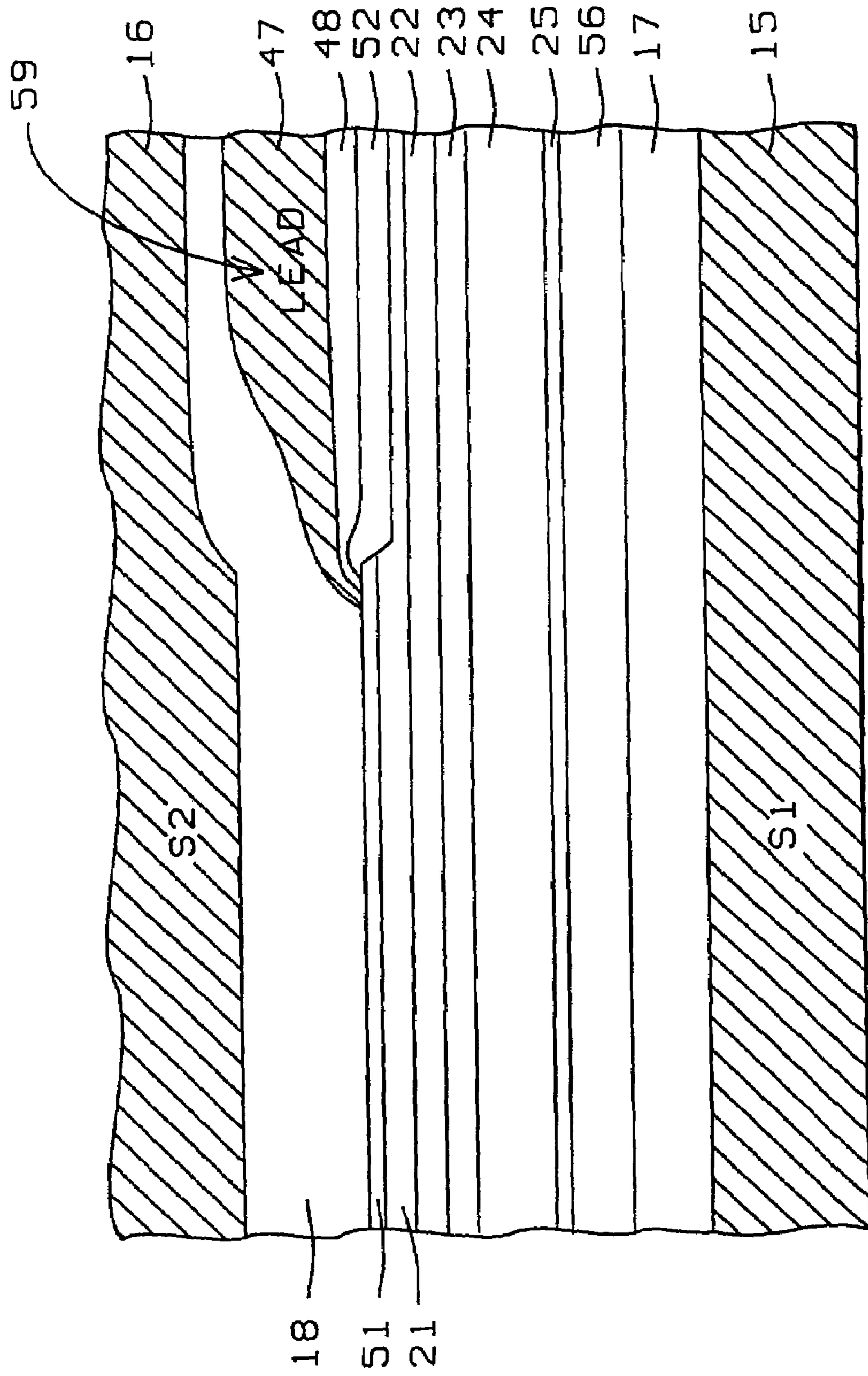

FIG. 5

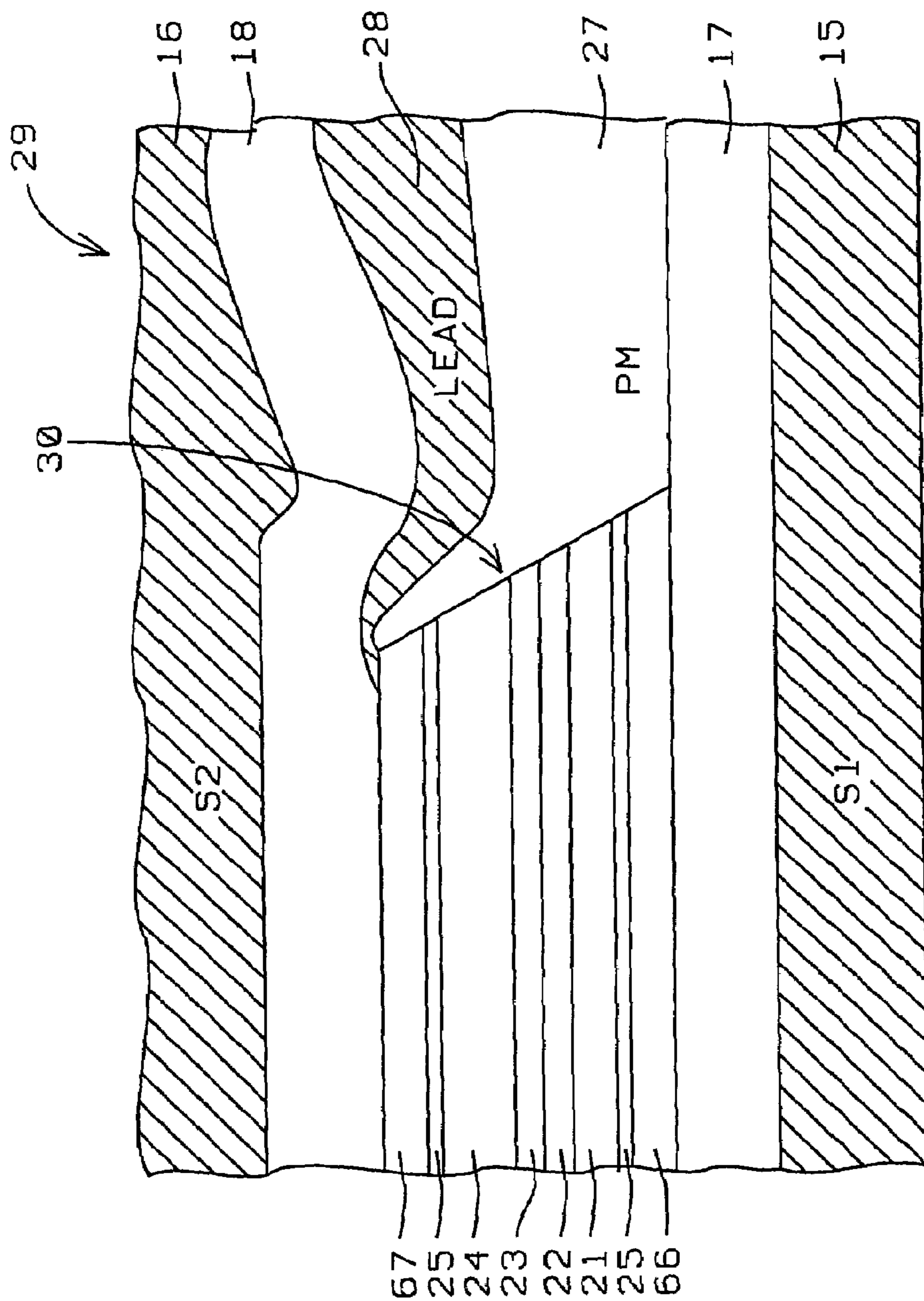

FIG. 6

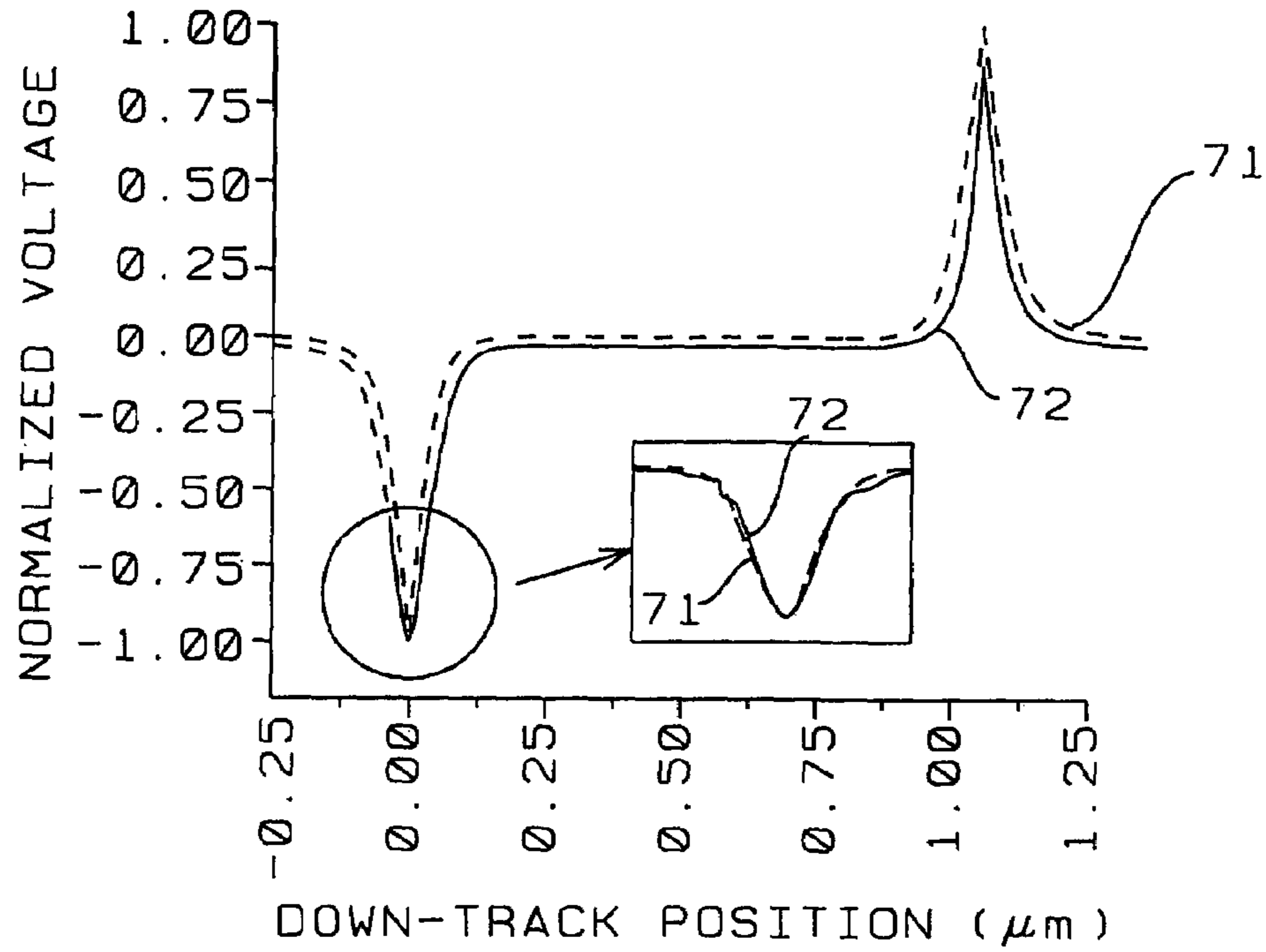

FIG. 7

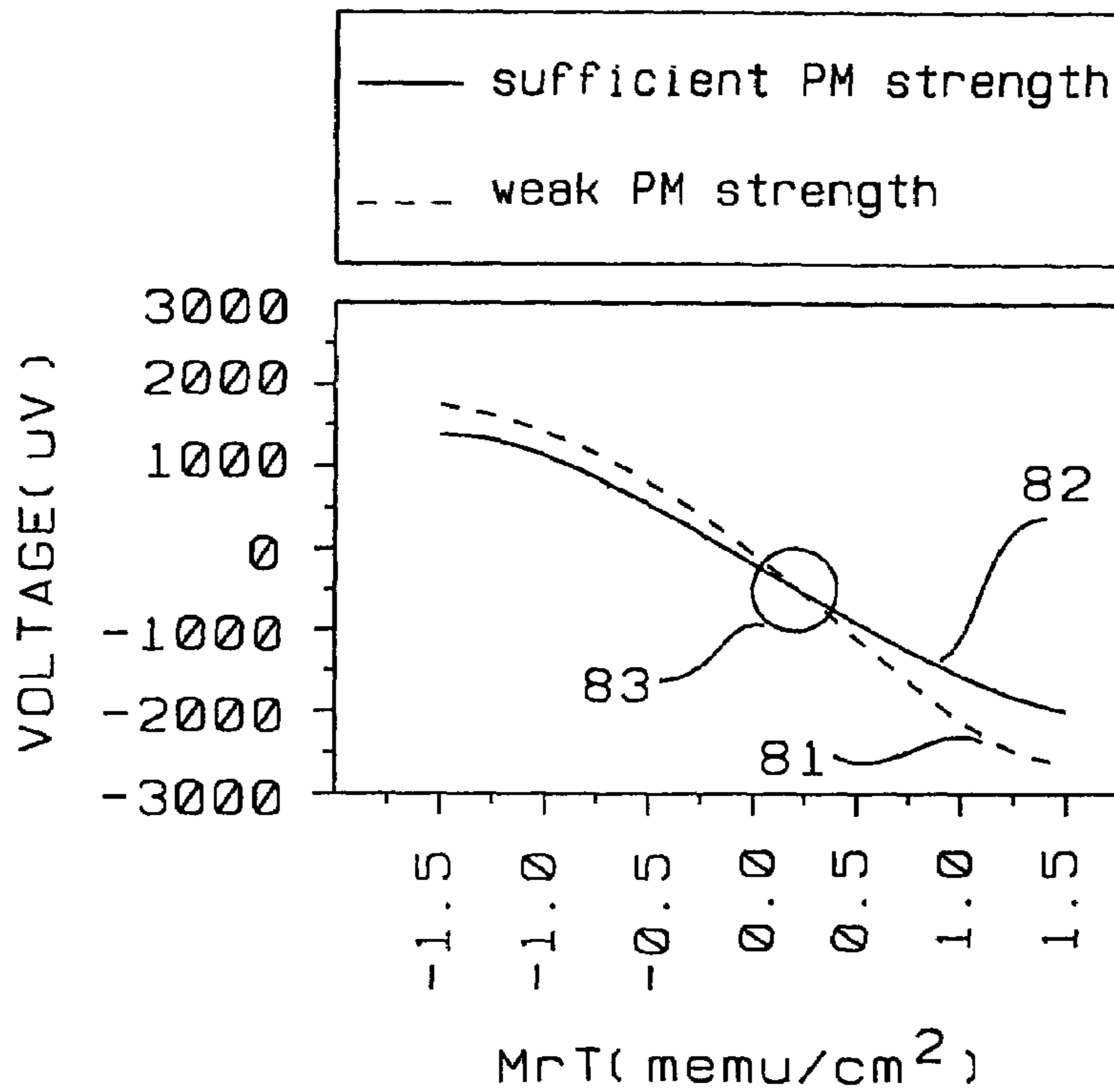

FIG. 8

INTEGRATED SPIN VALVE HEAD

This is a division of patent application Ser. No. 09/696, 134, filing date Oct. 26, 2000 now U.S. Pat. No. 6,885,527, Integrated Spin Valve Head, assigned to the same assignee as the present invention, which is herein incorporated by reference in its entirety.

FIELD OF THE INVENTION

The invention relates to the general field of magnetic recording with particular reference to improving linear resolution.

BACKGROUND OF THE INVENTION

The present invention is concerned with the manufacture of the read element in a magnetic disk system. This is a thin slice of material located between two magnetic shields which we will refer to as primary shields. The principle governing operation of the read sensor is the change of resistivity of certain materials in the presence of a magnetic field (magneto-resistance). In particular, most magnetic materials exhibit anisotropic behavior in that they have a preferred direction along which they are most easily magnetized (known as the easy axis). The magneto-resistance effect manifests itself as a decrease in resistivity when the material is magnetized in a direction perpendicular to the easy axis, said decrease being reduced to zero when magnetization is along the easy axis. Thus, any magnetic field that changes the direction of magnetization in a magneto-resistive material can be detected as a change in resistance.

It is now known that the magneto-resistance effect can be significantly increased by means of a structure known as a spin valve (SV). The resulting increase (known as Giant magneto-resistance or GMR) derives from the fact that electrons in a magnetized solid are subject to significantly less scattering by the lattice when their own magnetization vectors (due to spin) are parallel (as opposed to anti-parallel) to the direction of magnetization of the solid as a whole.

The key elements of a spin valve structure are two magnetic layers separated by a non-magnetic layer. The thickness of the non-magnetic layer is chosen so that the magnetic layers are sufficiently far apart for exchange effects to be negligible (the layers do not influence each other's magnetic behavior at the atomic level) but are close enough to be within the mean free path of conduction electrons in the material. If, now, these two magnetic layers are magnetized in opposite directions and a current is passed through them along the direction of magnetization, half the electrons in each layer will be subject to increased scattering while half will be unaffected (to a first approximation). Furthermore, only the unaffected electrons will have mean free paths long enough for them to have a high probability of crossing the non magnetic layer. However, once these electron 'switch sides', they are immediately subject to increased scattering, thereby becoming unlikely to return to their original side, the overall result being a significant increase in the resistance of the entire structure.

In order to make use of the GMR effect, the direction of magnetization of one the layers must be permanently fixed, or pinned. Pinning is achieved by first magnetizing the layer (by depositing and/or annealing it in the presence of a magnetic field) and then permanently maintaining the magnetization by over coating with a layer of antiferromagnetic material. The other layer, by contrast, is a "free layer" whose

direction of magnetization can be readily changed by an external field (such as that associated with a bit at the surface of a magnetic disk).

Structures in which the pinned layer is at the top are referred to as top spin valves. Similarly, It is also possible to form a 'bottom spin valve' structure where the pinned layer is deposited first. Although not directly connected to the GMR effect, an important feature of spin valve structures is a pair of longitudinal bias stripes that are permanently magnetized in a direction parallel to the long dimension of the device. Their purpose is to prevent the formation of multiple magnetic domains in the free layer portion of the GMR sensor, particularly near its ends.

FIG. 1 shows a typical structure that embodies the features described above. As noted above, the device is sandwiched between two primary shields **11** and **12**. Currently, the shield-to-shield separation of a spin valve head cannot be below about 800 Å, mainly due to the sensor-to-shield shorting problem. This is pointed to in the figure by arrow **13**. Since improvements in the density of recorded data require that this distance be reduced below 800 Å, there is a need for a structure (and a process for manufacturing it) that is not susceptible to said shorting problem.

An application that describes a structure that is related to that disclosed by the present invention was filed on Sep. 30, 1999 as application Ser. No. 09/408,492. Additionally, a routine search of the prior art was performed and the following references of interest were found:

In U.S. Pat. No. 5,978,182, Kanai et al. show a SV with a first soft magnetic layer. In U.S. Pat. No. 5,608,593, Kim et al. shows a SV with a non-magnetic (e.g., Cr) under-layer. Takada et al show a stabilizing layer with an under-layer of Cr and a hard magnetic layer in U.S. Pat. No. 5,828,527, while Ohsawa et al. (U.S. Pat. No. 5,777,542), Dykes et al. (U.S. Pat. No. 5,668,688), and Hsiao et al. (U.S. Pat. No. 5,999,379) all show related SV devices with shield layers.

SUMMARY OF THE INVENTION

It has been an object of the present invention to provide a spin valve structure that is free of internal electrical shorting by maintaining a relatively large shield-to-shield spacing while continuing to obtain very narrow feedback pulse widths.

Another object of the invention has been to provide a process for manufacturing said spin valve structure.

A further object has been that said structure be given its longitudinal bias through either permanent magnet or exchange magnet means.

A still further object has been that said structure be either a top or a bottom spin valve.

These objects have been achieved by inserting a high permeability, high resistivity, thin film shield on the top or bottom (or both) sides of the spin valve sensor. A permeability greater than about 500 is required together with a resistivity about 5 times greater than that of the free layer and an $M_r T$ value for the thin film shield that is 4 times greater than that of the free layer. Five embodiments of the invention are described.

BRIEF DESCRIPTION OF THE DRAWINGS

FIG. 1 shows how a structure made according to earlier teachings is subject to shorting (through the dielectric layer that insulated the shield from the sensor) if made too thin.

3

FIGS. 2 and 3 show bottom spin valve structures with permanent magnet biasing, having a single thin film shield, as taught by the present invention.

FIG. 4 shows a bottom spin valve structure with exchange magnet biasing, having a single thin film shield, as taught by the present invention.

FIG. 5 shows a top spin valve structure with exchange magnet biasing, having a single thin film shield, as taught by the present invention.

FIG. 6 shows a bottom spin valve structure with permanent magnet biasing, having two thin film shields, as taught by the present invention.

FIG. 7 compares read back signal pulse shape for structures with and without the thin film shield.

FIG. 8 plots voltage against total magnetic moment for structures with and without the thin film shield.

DESCRIPTION OF THE PREFERRED EMBODIMENTS

As already noted above, present SV designs cannot have their shield-to-shield spacing thicknesses reduced below about 800 Å because of shorting through the dielectric insulating coverage over the conductor lead. In dual stripe MR structures, it has been observed that if one of the MR stripes is not performing correctly, the signal contribution is dominated by the other MR, so that the read back pulse width, PW_{50} , is reduced. PW_{50} is the pulse width measured at the 50% of amplitude point (in nanoseconds or nanometers). It is measured at low frequency to avoid interference between adjacent pulses.

The present invention solves this problem by the insertion of a high permeability, high resistivity thin film shield on the top or bottom (or both) sides of the spin valve sensor. Examples of materials suitable for the thin film shields include (but are not limited to) nickel-iron-chromium, cobalt-niobium-zirconium, and cobalt-niobium-hafnium. We now describe five embodiments of the present invention. Although each embodiment is described in terms of the process for its manufacture, the structure of each embodiment will become apparent as each manufacturing process is disclosed. The following compositions and thickness ranges are common to all embodiments:

TABLE I

LAYER	COMPOSITION	THICKNESS (Å)
free	$Co_{90}Fe_{10}$, Ni_8Fe_{19}	5–50
non-magnetic spacer	Cu	12–22
pinned	$Co_{90}Fe_{10}$	10–30
pinning	$Ni_{45}Mn_{55}$, $Mn_{50}Pt_{50}$	80–200
dielectric	Al_2O_3 , AlN	100–200
Thin film shield	NiFeCr, CoZrNb, CoHfNb, CoZrHf, CoFeX (X = Cr, N, Ta, Ti)	50–400
decoupling	TaO, NiCr, NiFeCr	20–50

First Embodiment

This process is for manufacturing a top spin valve structure. It begins with the provision the first (lower) of the two primary magnetic shields. This can be seen as layer 15 in FIG. 2 on which dielectric layer 17 is deposited, followed by the deposition of free layer 21. This is followed by the deposition of non-magnetic layer 22 onto which is deposited pinned layer 23. Next, onto pinned layer 23 there is depos-

4

ited anti-ferromagnetic layer 24 for use as a pinning layer. This completes formation of the spin valve itself.

Now follows a key feature of the invention. On anti-ferromagnetic layer 24, decoupling layer 25 is deposited, followed by the deposition of thin film shield 26. The purpose of the decoupling layer is to avoid any exchange coupling of the thin film shield by layer 24. The thin film shield is a layer of ferromagnetic material having a permeability greater than about 500. It needs to have as high an electrical resistivity as possible within other constraints of the structure. It is required to be at least 5 times more resistive than the free layer. Since the latter is about 25 micro-ohm-cm, a value greater than about 125 micro-ohm-cm is to be preferred. The thickness of the thin film shield should be such that the moment-thickness product (of the thin film shield) is 2–5 times that of the free layer. The presence of this thin film shield allows relatively thicker dielectric layers to be used, thereby reducing or eliminating the chances of shorting, while still being able to obtain very narrow feedback pulse widths (namely PW_{50}).

To initiate completion of the structure, trench 29 is formed using conventional patterning and etching. This trench extends through thin film shield 26 down as far as the top surface of dielectric layer 17. The trench has a sidewall 30 that slopes at an angle of about 20 degrees. Onto this sidewall, as well as the exposed surface of dielectric layer 17, is selectively deposited layer 27 of a ferromagnetic material (such as CoCrPt) that is suitable for use as a permanent magnet, the direction of permanent magnetization being set by a field that is present during or after deposition of the layer. Layer 27 will serve to provide longitudinal bias to the structure, as discussed earlier.

With layer 27 in place, a layer of conductive material 28, suitable for use as a connecting lead to the structure, is selectively deposited thereon. This is followed by the deposition of second dielectric layer 18 onto which is deposited upper primary magnetic shield 16.

Second Embodiment

This process is also for manufacturing a top spin valve structure. Referring now to FIG. 3, this embodiment begins with the provision of the first (lower) of the two primary magnetic shields 15 on which dielectric layer 17 is deposited. Now follows a key feature of the invention, namely the deposition of thin film shield 36. The thin film shield is a layer of high permeability (greater than about 500) ferromagnetic material. It needs to have as high an electrical resistivity as possible within other constraints of the structure. It is required to be at least 5 times more resistive than the free layer. Since the latter is about 25 micro-ohm-cm, a value greater than about 125 micro-ohm-cm is to be preferred. The thickness of the thin film shield should be such that the moment-thickness product (of the thin film shield) is 2–5 times that of the free layer. The presence of this thin film shield allows relatively thicker dielectric layers to be used, thereby reducing or eliminating the chances of shorting, while still being able to obtain very narrow feedback pulse widths.

With the thin film shield in place, decoupling layer 25 is laid down followed by the deposition of free layer 21. This is followed by the deposition of non-magnetic layer 22 onto which is deposited pinned layer 23. Next, onto pinned layer 23 there is deposited anti-ferromagnetic layer 24 for use as a pinning layer. This completes formation of the spin valve itself.

5

Completion of the structure then continues with the formation of trench **29**, using conventional patterning and etching. This trench extends through layer **24** down as far as the top surface of dielectric layer **17**. The trench has a sidewall **30** that slopes at an angle of about 20 degrees. Onto this sidewall, as well as the exposed surface of dielectric layer **17**, is selectively deposited layer **27** of a ferromagnetic material (such as CoCrPt) that is suitable for use as a permanent magnet, the direction of permanent magnetization being set by a field that is present during deposition of the layer or by later annealing in such a field. Layer **27** will serve to provide longitudinal bias to the structure, as discussed earlier.

With layer **27** in place, a layer of conductive material **28**, suitable for use as a connecting lead to the structure, is selectively deposited thereon. This is followed by the deposition of second dielectric layer **18** onto which is deposited upper primary magnetic shield **16**.

Third Embodiment

This process is also for manufacturing a top spin valve structure. We refer now to FIG. **4** which begins with the provision of the first (lower) of the two primary magnetic shields **15** onto which is deposited dielectric layer **17**. Then, on a selected area at the surface of layer **17**, a layer of conductive material **47**, suitable for use as a connecting lead to the structure, is deposited. Then, on layer **47** only, layer **48** of a ferromagnetic material suitable for use as an exchange magnet is deposited. This will serve to provide the needed longitudinal bias for the structure, as discussed above.

Then, free layer **21** is deposited over the full surface followed by the deposition of non-magnetic layer **22** onto which is deposited pinned layer **23**. Next, onto pinned layer **23** there is deposited anti-ferromagnetic layer **24** for use as a pinning layer.

Now follows a key feature of the invention. On anti-ferromagnetic layer **24**, decoupling layer **25** is deposited, followed by the deposition of thin film shield **46**. The purpose of the decoupling layer is to avoid any pinning of the thin film shield by layer **24**. The thin film shield is a layer of high permeability (greater than about 500) ferromagnetic material. It needs to have as high an electrical resistivity as possible within other constraints of the structure. It is required to be at least 5 times more resistive than the free layer. Since the latter is about 25 micro-ohm-cm, a value greater than about 125 micro-ohm-cm is to be preferred. The presence of this thin film shield allows a relatively large shield-to-shield spacing to be maintained (thereby reducing or eliminating the chances of shorting) while still being able to obtain very narrow feedback pulse widths.

Since the lead and biasing structure is already in place, all that remains to complete this embodiment is the deposition of second dielectric layer **18** onto which is deposited upper primary magnetic shield **16**.

Fourth Embodiment

Unlike the previous three embodiments, this process is for manufacturing a bottom spin valve structure. Referring to FIG. **5**, it begins, as before, with the provision of the first (lower) of the two primary magnetic shields **15** onto which dielectric layer **17** is deposited. A key feature of the invention now follows, namely the deposition of thin film shield **56**. The thin film shield is a layer of high permeability (greater than 500) ferromagnetic material. It needs to have

6

as high an electrical resistivity as possible within other constraints of the structure. It is required to be at least 5 times more resistive than the free layer. Since the latter is about 25 micro-ohm-cm, a value greater than about 125 micro-ohm-cm is to be preferred. The thickness of the thin film shield should be such that the moment-thickness product (of the thin film shield) is 2–5 times that of the free layer. The presence of this thin film shield allows relatively thicker dielectric layers to be used, thereby reducing or eliminating the chances of shorting, while still being able to obtain very narrow feedback pulse widths (namely PW_{50}).

With the thin film shield in place, decoupling layer **25** is laid down followed by the deposition of anti-ferromagnetic layer **24**. This is followed by the deposition of pinned layer **23** onto which is deposited non-magnetic layer **22**. Next, onto non-magnetic layer **22** there is deposited free layer **21** which completes formation of the spin valve itself.

To initiate completion of the structure, shallow trench **59** is formed using conventional patterning and etching. This trench extends part way through the free layer **21**. On the part of the free layer that lies outside the trench, capping layer **51** of tantalum, tantalum oxide, and alumina, among others, is deposited. Its purpose is to provide protection against oxidation or other forms of contamination. On the part of the free layer that forms the base of the trench, refill layer **52** of the same material as used for the free layer (typically permalloy).

Layer **48**, comprising a ferromagnetic material suitable for use as an exchange magnet is then selectively deposited onto the trench base portion of layer **21** where it will provide longitudinal bias to the structure. Then, layer **47** of conductive material suitable for use in connecting leads to the structure is selectively deposited onto exchange magnet layer **48**. To complete this embodiment, second dielectric layer **18** is deposited onto layers **47** and **51** followed by the overall deposition of upper primary magnetic shield **16**.

Fifth Embodiment

The process of this embodiment is also for manufacturing a top spin valve structure but, unlike the previous four embodiments, it makes use of two thin film shields. While adding slightly to the overall thickness, the two shield structure has the advantage that, since PW_{50} is defined by the distance between these two shields, even narrower pulse widths can be obtained. Note also that this scheme is not limited to conventional spin-valve structures. It is also readily applicable to synthetic anti-ferromagnet SVs and Dual-SV applications.

Referring now to FIG. **6**, this embodiment begins with the provision of the first (lower) of the two primary magnetic shields **15** on which dielectric layer **17** is deposited. Now follows a key feature of the invention, namely the deposition of thin film shield **66**. The thin film shield is a layer of high permeability (greater than 500) ferromagnetic material. It needs to have as high an electrical resistivity as possible within other constraints of the structure. It is required to be at least 5 times more resistive than the free layer. Since the latter is about 25 micro-ohm-cm, a value greater than about 125 micro-ohm-cm is to be preferred. The thickness of the thin film shield should be such that the moment-thickness product (of the thin film shield) is 2–5 times that of the free layer. The presence of this thin film shield allows relatively thicker dielectric layers to be used, thereby reducing or eliminating the chances of shorting, while still being able to obtain very narrow feedback pulse widths (namely PW_{50}).

With the thin film shield in place, decoupling layer **25** is laid down followed by the deposition of free layer **21**. This is followed by the deposition of non-magnetic layer **22** onto which is deposited pinned layer **23**. Next, onto pinned layer **23** there is deposited anti-ferromagnetic layer **24** for use as a pinning layer.

Now follows another key feature of the invention. On anti-ferromagnetic layer **24**, decoupling layer **25** is deposited, followed by the deposition of a second thin film shield **67**. The second thin film shield has the same properties as the first thin film shield. The presence of the thin film shields allows a relatively large shield-to-shield spacing to be maintained (thereby reducing or eliminating the chances of shorting) while still being able to obtain very narrow feed-back pulse widths.

To initiate completion of the structure, trench **29** is formed using conventional patterning and etching. This trench extends through thin film shield **67** down as far as the top surface of dielectric layer **17**. The trench has a sidewall **30** that slopes at an angle of about 20 degrees. Onto this sidewall, as well as the exposed surface of dielectric layer **17**, is selectively deposited layer **27** of a ferromagnetic material (such as CoCrPt) that is suitable for use as a permanent magnet, the direction of permanent magnetization being set by a field that is present during deposition of the layer or by later annealing in such a field. Layer **27** will serve to provide longitudinal bias to the structure, as discussed earlier.

With layer **27** in place, a layer of conductive material **28**, suitable for use as a connecting lead to the structure, is selectively deposited thereon. This is followed by the deposition of second dielectric layer **18** onto which is deposited upper primary magnetic shield **16**.

In FIGS. **7** and **8** we present data that confirms the effectiveness of the present invention. FIG. **7** illustrates the reduction in PW_{50} that the present invention brings about. Shown there are micro-magnetic simulated playback waveforms. The cases involved are curve **71**, conventional SV head with 800 Å shield-to-shield spacing (dashed), and curve **72** which is for double-sided thin film shields (solid), the free layer being located at the center of the two thin film shields. The spacing between the thin film shields is 300 Å. The total distance between the primary shields is about 1000 Å. The $M_r T$ (remnant magnetization × layer thickness = total magnetic moment) of both thin film shields is four times that of the free layer. The resistivity of the thin film shield is assumed to be nine times greater than that of the free layer. Simulation shows that the PW_{50} for the conventional SV is about 700 Å while the PW_{50} for the thin film shield head is about 550 Å, which is approximately equivalent to a 450 Å shield-to-shield space in the case without the thin film shields.

Since the thin film shields are magnetic materials, the fringe field from the shield layers will affect the performance of the free layer and cause instability if they are not properly biased. No additional bias scheme is needed for the continuous thin film shield. For the permanent magnet (PM) abutted scheme (FIGS. **2**, **3**, and **6**), a permanent magnet is placed adjacent to both sides of the thin film shield to provide a horizontal bias along the track width direction, just as the free layer is given its bias. The highly localized PM field removes the magnetic charge at the ends of the thin film shield, while still keep the high permeability property of the shield layers.

From the curves shown in FIG. **7**, the data displayed in TABLE II can be derived:

TABLE II

structure	PW_{50} (Å)	equivalent shield-to-shield spacing
no TF shield	700	800
with TF shield	550	450

This shows that when the thin film shield disclosed in the present invention is used, the 550 Angstrom PW_{50} that is obtained is equivalent to a shield-to-shield spacing of only 450 Angstroms.

FIG. **8** shows calculated transfer curves for the double-sided thin film shield for two different PM bias strength presented as voltage vs. total magnetic moment in millielectromagnetic units. A “kink” **83** appears in the transfer curve where hard bias curve **81** for a field that is not strong enough crosses curve **82** which is for a field of adequate strength. Calculations show that a stability coefficient $(M_r T)_{PM} / (M_r T)_{TFS}$ of 1 is sufficient to provide the proper horizontal bias for the thin film shields.

Note that since the thin film shield is at least two times thicker than the free layer, the degree of the magnetization rotation in the thin film shield is usually much less than in the free layer. The magnetization in the thin film shield is essentially oriented along the track width direction. The change of the free layer bias level due to the flux from the shield layer is not significant. The effect of current field from the thin film shield layers on the bias is also negligible due to the high resistivity of the shield material.

While the invention has been particularly shown and described with reference to the preferred embodiments thereof, it will be understood by those skilled in the art that various changes in form and details may be made without departing from the spirit and scope of the invention.

What is claimed is:

1. A top spin valve structure, comprising:
 - on a first dielectric layer, a layer of magnetic material suitable for use as a free layer in said spin valve;
 - on the free layer, a layer of non-magnetic material;
 - on the layer of non-magnetic material, a layer of magnetic material suitable for use as a pinned layer in said spin valve;
 - on the pinned layer, a layer of an anti-ferromagnetic material suitable for use as a pinning layer in said spin valve;
 - on the anti-ferromagnetic layer, a layer of material suitable for use as a decoupling layer; and
 - on the decoupling layer, a thin film shield that further comprises a layer of high permeability ferromagnetic material, said material having an electrical resistivity greater than about 125 micro-ohm-cm and a thickness such that the product of its moment and thickness is 2 to 5 times that of the free layer;
 - a trench that extends through the thin film shield as far as said first dielectric layer, said trench having a sidewall that slopes;
 - on the first dielectric layer and on the sidewall, a layer of a ferromagnetic material suitable for use as a permanent magnet for providing longitudinal bias to the structure;
 - on the permanent magnet layer, a layer of conductive material suitable for use as a connecting lead to the structure; and

9

on the thin film shield and on the conductive lead layer, a second dielectric layer.

2. The structure described in claim 1 wherein the thin film shield is selected from the group consisting of nickel-iron-chromium, cobalt-niobium-zirconium, cobalt-niobium-hafnium, iron-cobalt-nitrogen, iron-cobalt-chromium, iron-cobalt-tantalum, and iron-cobalt-titanium and has a permeability greater than about 500.

3. A top spin valve structure, including a free layer, comprising:

on a first dielectric layer, a thin film shield that further comprises a layer of high permeability ferromagnetic material, said material having an electrical resistivity greater than about 125 micro-ohm-cm and a thickness such that the product of its moment and thickness is 2

to 5 times that of the free layer;

on the thin film shield, a layer of material suitable for use as a decoupling layer;

on said decoupling layer, a layer of magnetic material suitable for use as the free layer in said spin valve;

on the free layer a layer of non-magnetic material;

on the layer of non-magnetic material, a layer of magnetic material suitable for use as a pinned layer in said spin valve;

on the pinned layer, a layer of an anti-ferromagnetic material suitable for use as a pinning layer in said spin valve;

a trench that extends through the anti-ferromagnetic layer as far as said first dielectric layer, said trench having a sidewall that slopes;

on the first dielectric layer and on the sidewall, a layer of a ferromagnetic material suitable for use as a permanent magnet for providing longitudinal bias to the structure;

on the permanent magnet layer, a layer of conductive material suitable for use as a connecting lead to the structure; and

on the anti-ferromagnetic layer and on the conductive lead layer, a second dielectric layer.

4. The structure described in claim 3 wherein the thin film shield is selected from the group consisting of nickel-iron-chromium, cobalt-niobium-zirconium, cobalt-niobium-hafnium, iron-cobalt-nitrogen, iron-cobalt-chromium, iron-cobalt-tantalum, and iron-cobalt-titanium and has a permeability greater than about 500.

5. A top spin valve structure, comprising:

on part of a first dielectric layer, a layer of conductive material suitable for use as a connecting lead to the structure;

on the conductive lead material, a layer of a ferromagnetic material suitable for use as an exchange magnet for providing longitudinal bias to the structure;

on said first dielectric layer and on the exchange magnet layer, a layer of magnetic material suitable for use as a free layer in said spin valve;

on the free layer, a layer of non-magnetic material;

on the layer of non-magnetic material, a layer of magnetic material suitable for use as a pinned layer in said spin valve;

on the pinned layer, a layer of an anti-ferromagnetic material suitable for use as a pinning layer in said spin valve;

on the anti-ferromagnetic layer, a layer of material suitable for use as a decoupling layer;

on the decoupling layer, a thin film shield that further comprises a layer of high permeability ferromagnetic material, said material having an electrical resistivity

10

greater than about 125 micro-ohm-cm and a thickness such that the product of its moment and thickness is 2 to 5 times that of the free layer; and

on the thin film shield, a second dielectric layer.

6. The structure described in claim 5 wherein the thin film shield is selected from the group consisting of nickel-iron-chromium, cobalt-niobium-zirconium, cobalt-niobium-hafnium, iron-cobalt-nitrogen, iron-cobalt-chromium, iron-cobalt-tantalum, and iron-cobalt-titanium and has a permeability greater than about 500.

7. A bottom spin valve structure, including a free layer, comprising:

on a first dielectric layer, thin film shield that further comprises a layer of high permeability ferromagnetic material, said material having an electrical resistivity greater than about 125 micro-ohm-cm and a thickness such that the product of its moment and thickness is 2 to 5 times that of the free layer;

on the thin film shield, a layer of material suitable for use as a decoupling layer;

on the decoupling layer, a layer of an anti-ferromagnetic material suitable for use as a pinning layer in said spin valve;

on the anti-ferromagnetic layer, a layer of magnetic material suitable for use as a pinned layer in said spin valve;

on the pinned layer, a layer of non-magnetic material;

on said pinned layer, a layer of magnetic material suitable for use as a free layer in said spin valve;

a shallow trench that extends part way through the free layer, said trench having a sidewall that slopes;

on the free layer outside the trench, a capping layer selected from the group consisting of tantalum, tantalum oxide, and alumina;

on the free layer inside the trench, a layer of material that is the same as that of the free layer;

on the capping layer, a layer of a ferromagnetic material suitable for use as an exchange magnet for providing longitudinal bias to the structure;

on the exchange magnet layer, a layer of conductive material suitable for use in connecting leads to the structure;

on the conducting lead layer, a second dielectric layer.

8. The structure described in claim 7 wherein the thin film shield is selected from the group consisting of nickel-iron-chromium, cobalt-niobium-zirconium, cobalt-niobium-hafnium, iron-cobalt-nitrogen, iron-cobalt-chromium, iron-cobalt-tantalum, and iron-cobalt-titanium and has a permeability greater than about 500.

9. A double shielded top spin valve structure, including a free layer, comprising:

providing a lower primary magnetic shield on which is a first dielectric layer;

on a first dielectric layer, a first thin film shield that further comprises a first layer of high permeability ferromagnetic material, said material having an electrical resistivity greater than about 125 micro-ohm-cm and a thickness such that the product of its moment and thickness is 2 to 5 times that of the free layer;

on the first thin film shield, a layer of material suitable for use as a first decoupling layer;

on said first decoupling layer, a layer of magnetic material suitable for use as a free layer in said spin valve;

on the free layer, a layer of non-magnetic material;

on the layer of non-magnetic material, a layer of magnetic material suitable for use as a pinned layer in said spin valve;

11

on the pinned layer, a layer of an anti-ferromagnetic material suitable for use as a pinning layer in said spin valve;
 on the anti-ferromagnetic layer, a layer of material suitable for use as a second decoupling layer; and
 on the second decoupling layer, a second thin film shield that further comprises a second layer of high permeability ferromagnetic material, said material having an electrical resistivity greater than about 125 micro-ohm-cm and a thickness such that the product of its moment and thickness is 2 to 5 times that of the free layer;
 a trench that extends through the second thin film shield as far as said first dielectric layer, said trench having a sidewall that slopes;
 on the first dielectric layer and on the sidewall, a layer of a ferromagnetic material suitable for use as a perma

12

nent magnet for providing longitudinal bias to the structure;
 on the permanent magnet layer a layer of conductive material suitable for use as a connecting lead to the structure; and
 on the second thin film shield and on the conductive lead layer, a second dielectric layer.
10. The structure described in claim 9 wherein the thin film shields are selected from the group consisting of nickel-iron-chromium, cobalt-niobium-zirconium, cobalt-niobium-hafnium, iron-cobalt-nitrogen, iron-cobalt-chromium, iron-cobalt-tantalum, and iron-cobalt-titanium and has a permeability greater than about 500.

* * * * *