

US006993956B2

(12) **United States Patent**
Bouten et al.

(10) **Patent No.:** **US 6,993,956 B2**
(45) **Date of Patent:** **Feb. 7, 2006**

(54) **METHOD FOR MEASURING A PERMEATION RATE, A TEST AND AN APPARATUS FOR MEASURING AND TESTING**

(75) Inventors: **Petrus Cornelis Paulus Bouten**, Eindhoven (NL); **Giovanni Nisato**, Eindhoven (NL); **Peter Jan Slikkerveer**, Eindhoven (NL); **Henricus Franciscus Johannus Jacobus Van Tongeren**, Eindhoven (NL); **Eliav Itzhak Haskal**, Eindhoven (NL); **Paul Van Der Sluis**, Eindhoven (NL)

(73) Assignee: **Koninklijke Philips Electronics N.V.**, Eindhoven (NL)

(*) Notice: Subject to any disclaimer, the term of this patent is extended or adjusted under 35 U.S.C. 154(b) by 383 days.

(21) Appl. No.: **10/106,951**

(22) Filed: **Mar. 26, 2002**

(65) **Prior Publication Data**

US 2002/0152800 A1 Oct. 24, 2002

(30) **Foreign Application Priority Data**

Mar. 29, 2001 (EP) 01201229
Jan. 17, 2002 (EP) 02075202

(51) **Int. Cl.**

G01M 3/04 (2006.01)
G01N 15/08 (2006.01)
G01N 21/77 (2006.01)
G01D 21/00 (2006.01)

(52) **U.S. Cl.** **73/40; 73/38; 436/169; 116/206**

(58) **Field of Classification Search** **73/38, 73/40; 436/169, 170; 116/206; 702/81, 702/84, 31, 32, 33, 34, 35, 40**

See application file for complete search history.

(56) **References Cited**

U.S. PATENT DOCUMENTS

4,326,514 A *	4/1982	Eian	73/38
4,822,743 A *	4/1989	Wegrzyn	116/206
4,848,138 A *	7/1989	Marshall	73/40.7
4,987,849 A *	1/1991	Sherman	116/206
5,001,346 A *	3/1991	Barkhoudarian	250/330
5,009,218 A *	4/1991	Bachli	126/714
5,047,947 A *	9/1991	Stump	702/84
5,128,106 A *	7/1992	Buschmann et al.	116/206
5,323,774 A *	6/1994	Fehlauer	116/206
5,447,688 A *	9/1995	Moore	422/56
5,449,912 A *	9/1995	Mayer	250/343
5,926,262 A *	7/1999	Jung et al.	356/73
5,951,909 A *	9/1999	Verdicchio et al.	73/40
5,963,881 A *	10/1999	Kahn et al.	702/35
6,259,370 B1 *	7/2001	Takenoshita	340/605
6,622,059 B1 *	9/2003	Toprac et al.	700/121
2001/0034063 A1 *	10/2001	Saunders et al.	436/2
2003/0014205 A1 *	1/2003	Tabor	702/84

FOREIGN PATENT DOCUMENTS

EP 0629497 A2 * 12/1994

(Continued)

OTHER PUBLICATIONS

Patent Abstracts of Japan, Yamaguchi Susumu, "Material For Measuring Membrane Performance And Inspecting Leakage," Publication Number 60020135, Feb. 1, 1985, Application No. 58127783, Jul. 15, 1983.

Primary Examiner—Michael Cygan

(57) **ABSTRACT**

A method is proposed for measuring water permeability of substrates (1). A reactive compound (Ca, Ba) which reacts with a diffusing material, e.g. water, is applied on the substrate and the change in time of transmissivity, reflectivity of the layer is monitored in time.

16 Claims, 5 Drawing Sheets

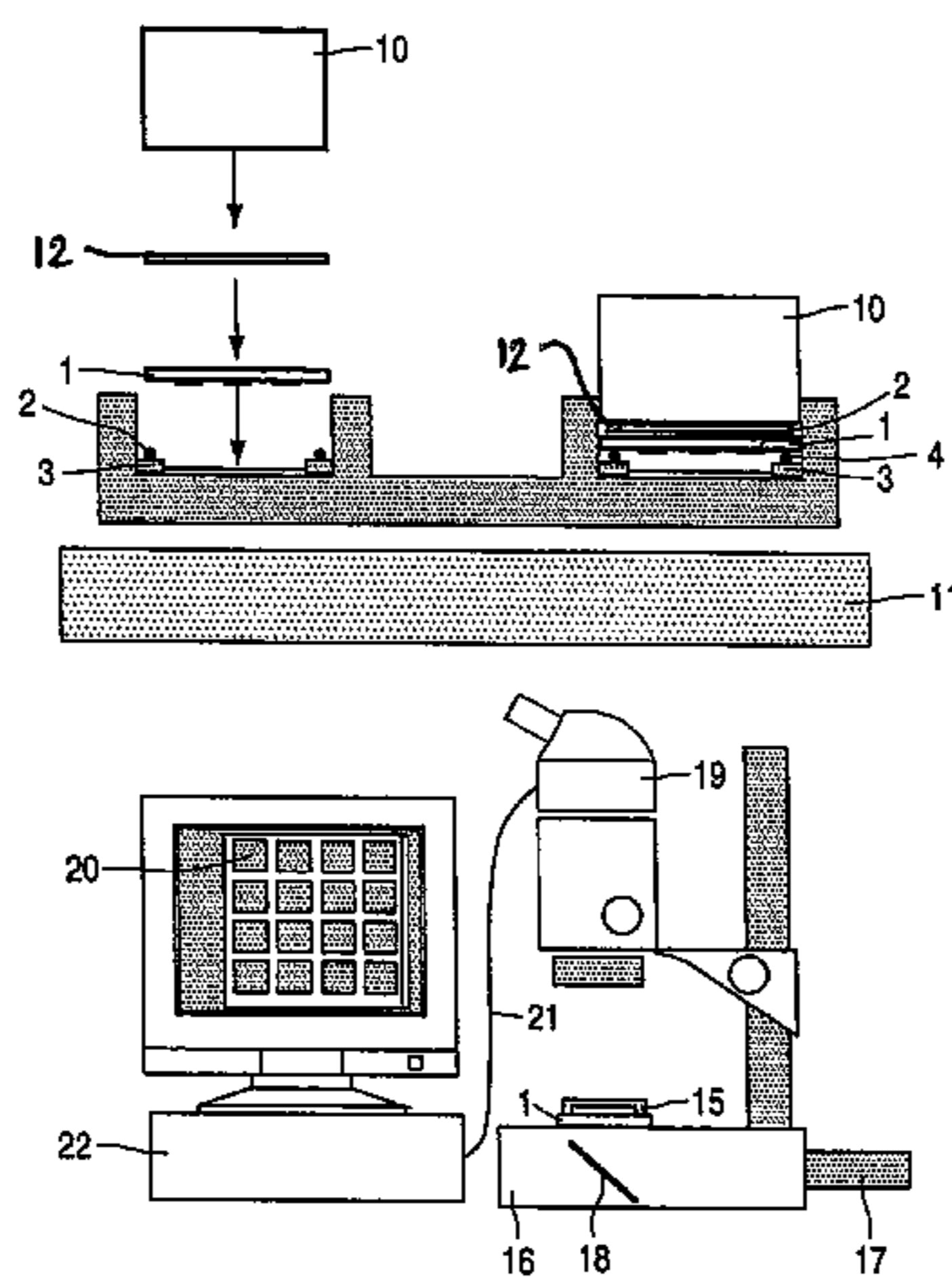

US 6,993,956 B2

Page 2

	FOREIGN PATENT DOCUMENTS	JP	02306132 A * 12/1990	73/40
JP	61031937 A * 2/1986			73/40
JP	62032336 A * 2/1987			73/40 * cited by examiner

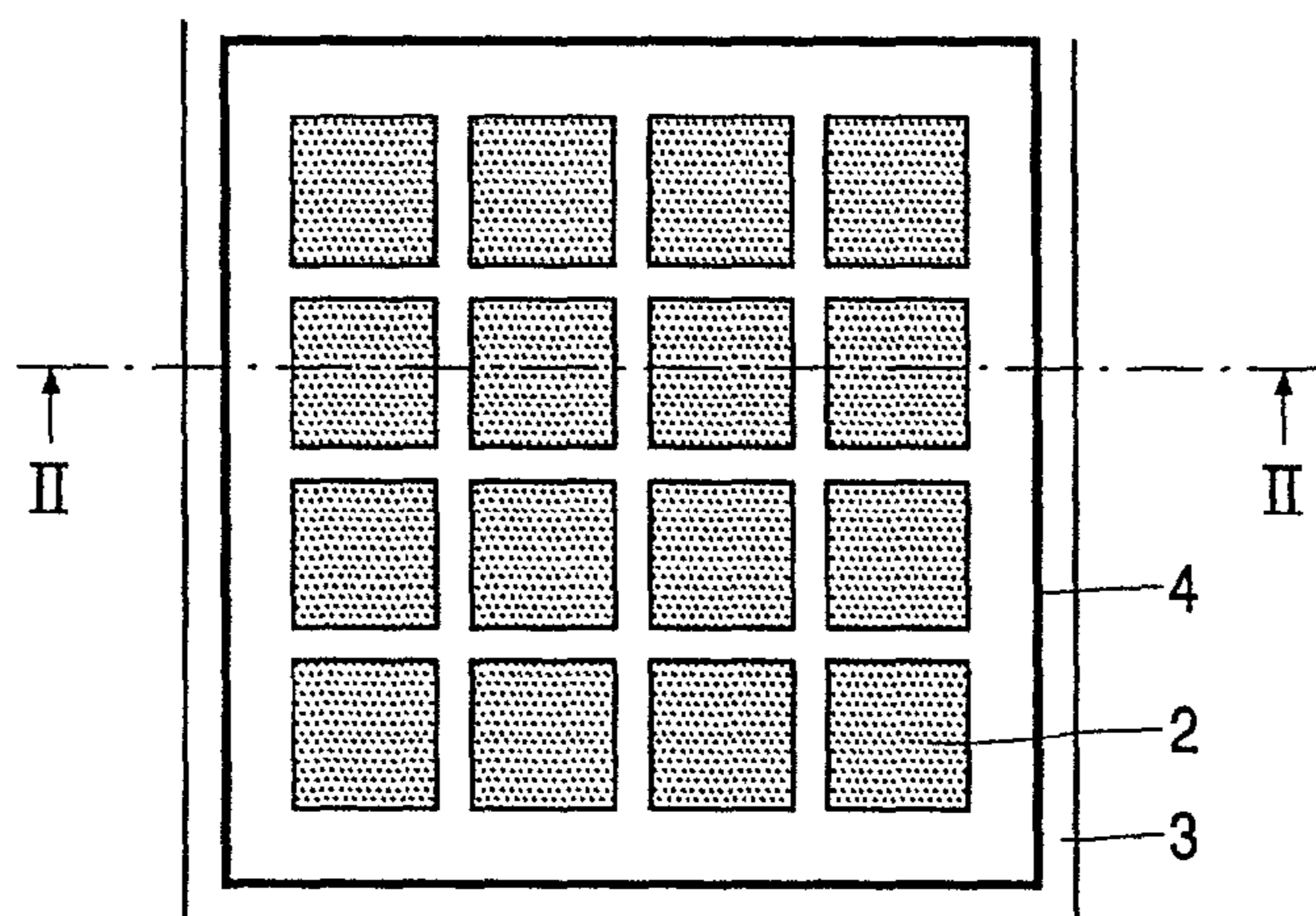

FIG. 1

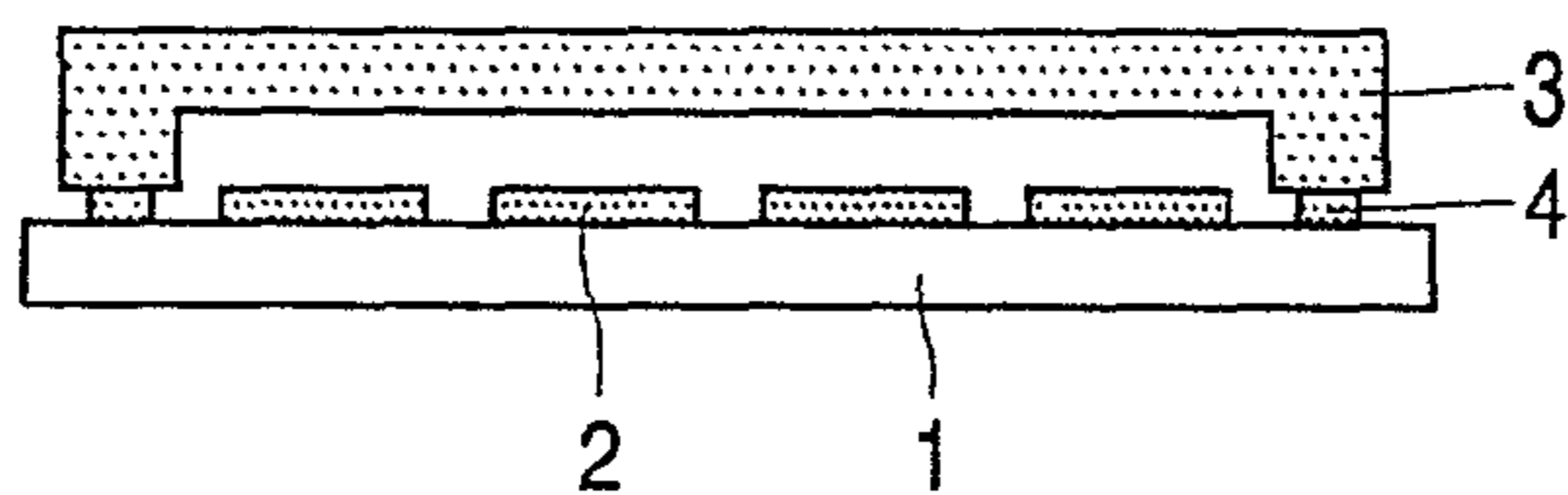

FIG. 2

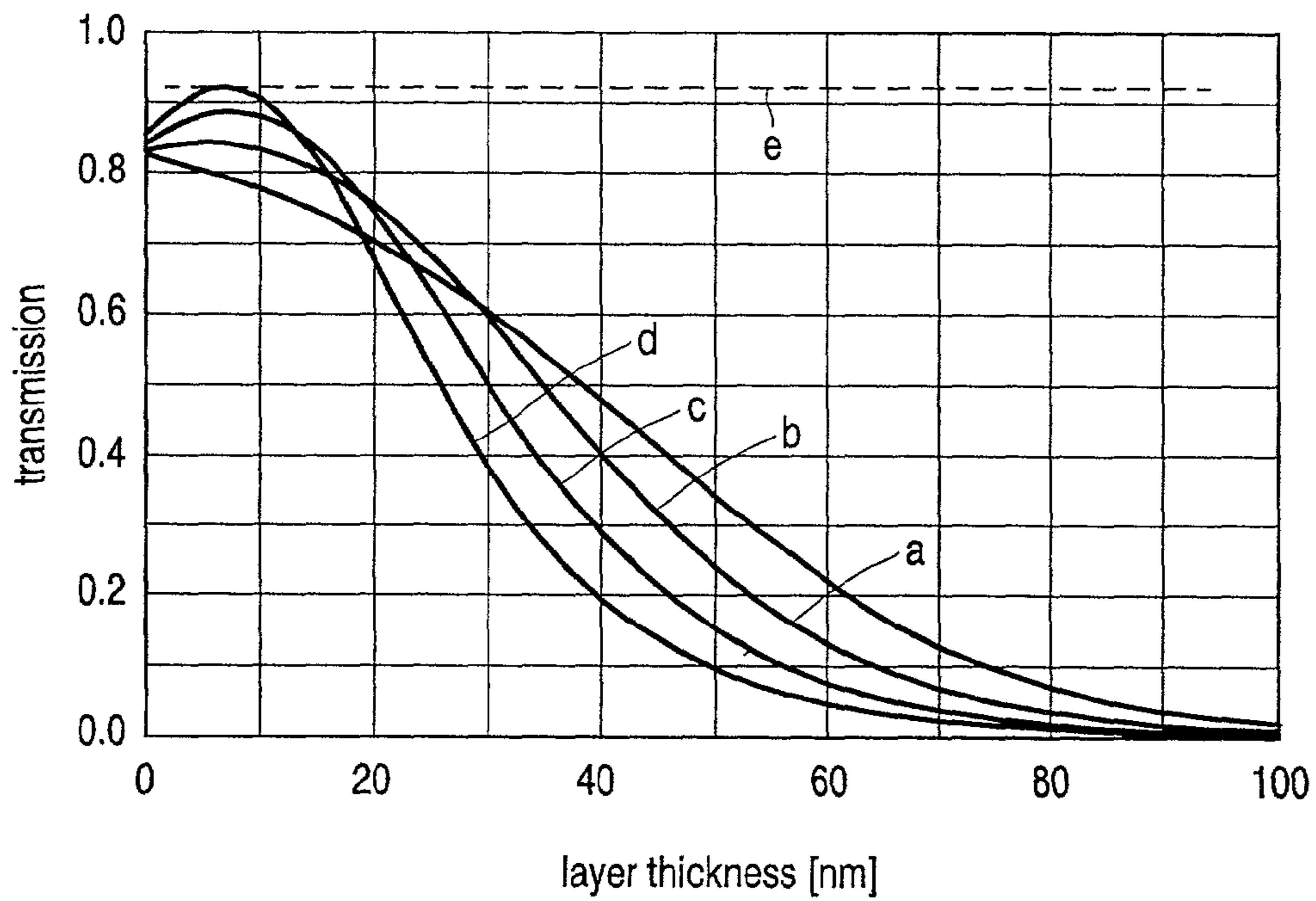

FIG. 3

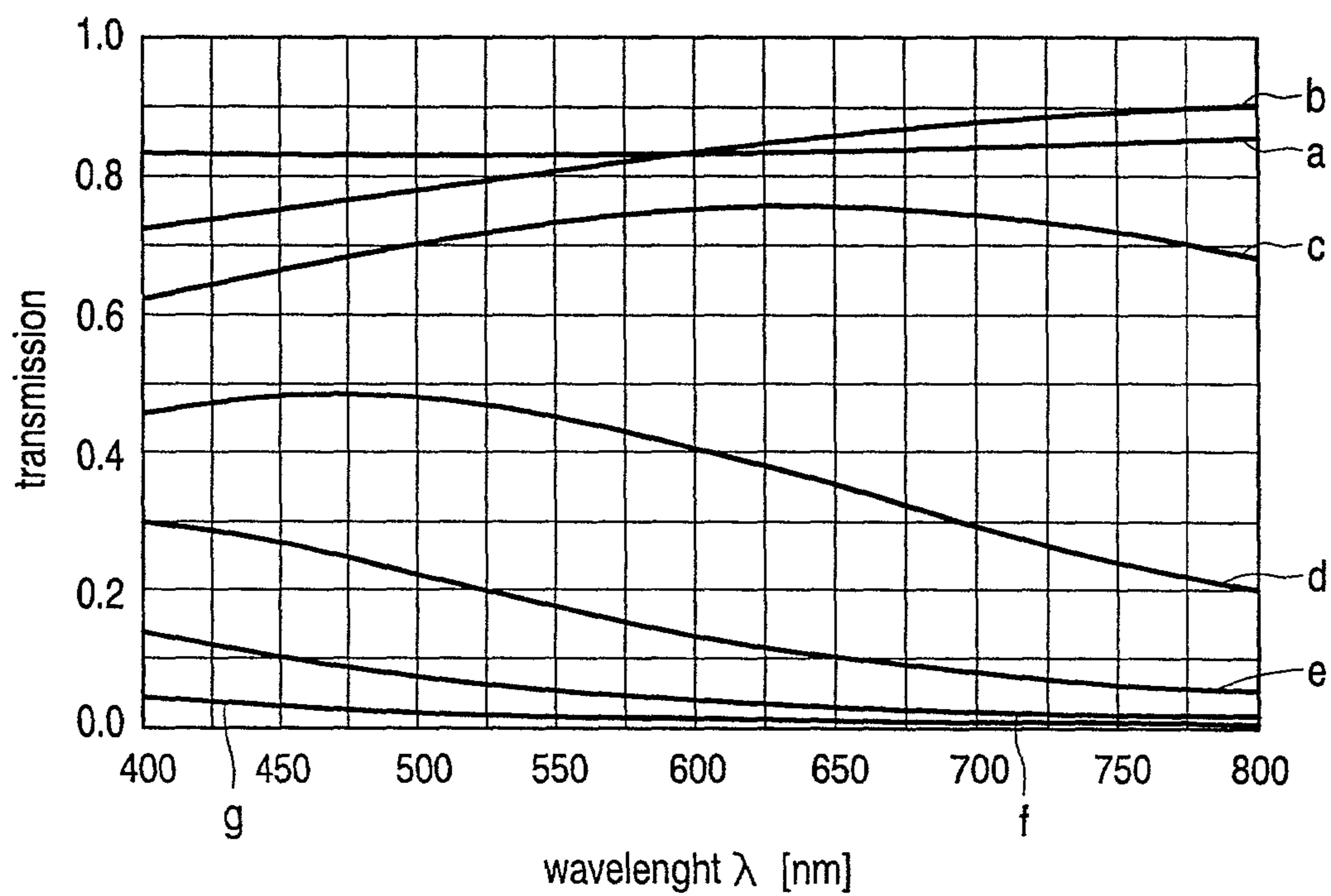

FIG. 4

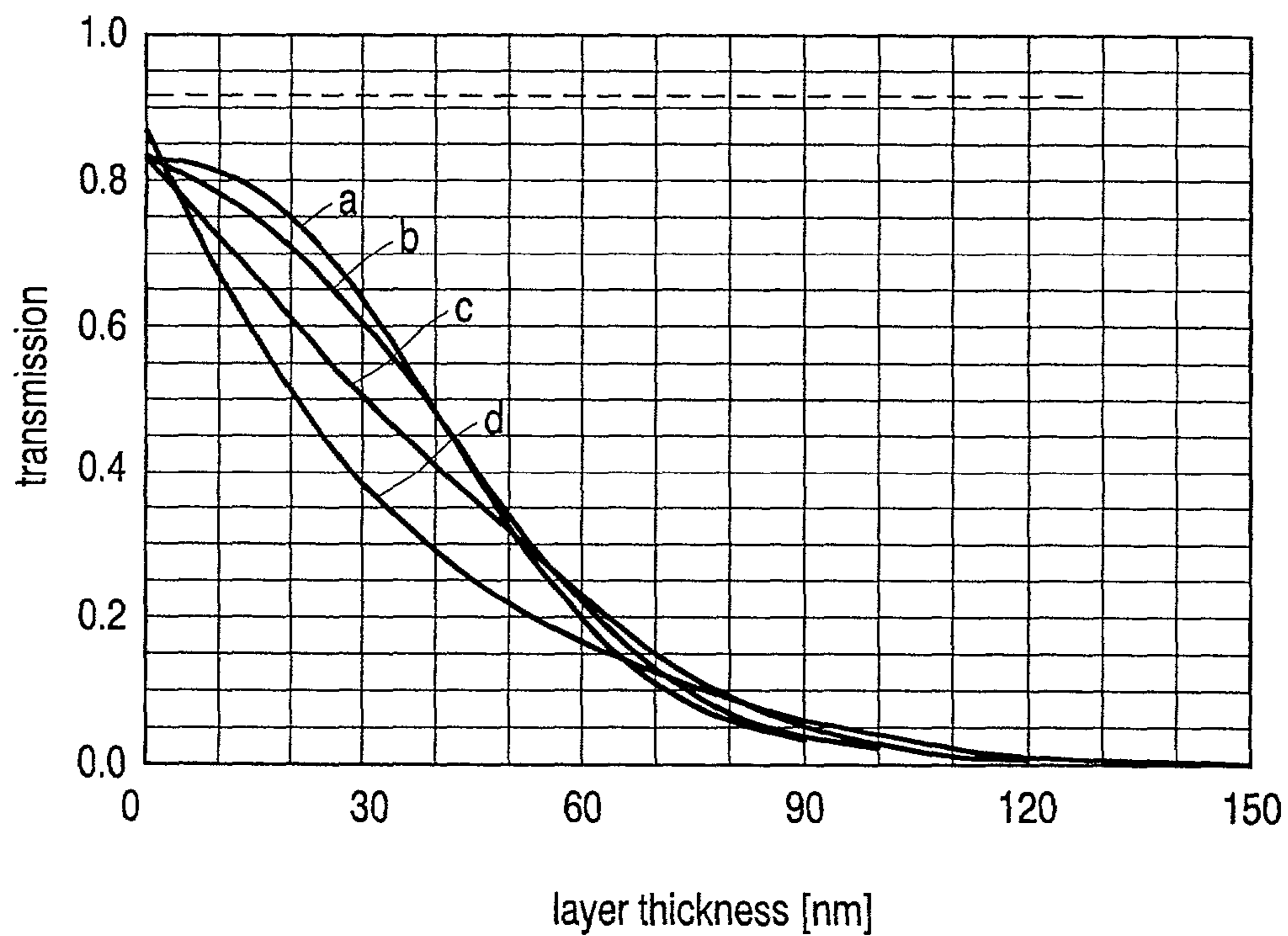

FIG. 5

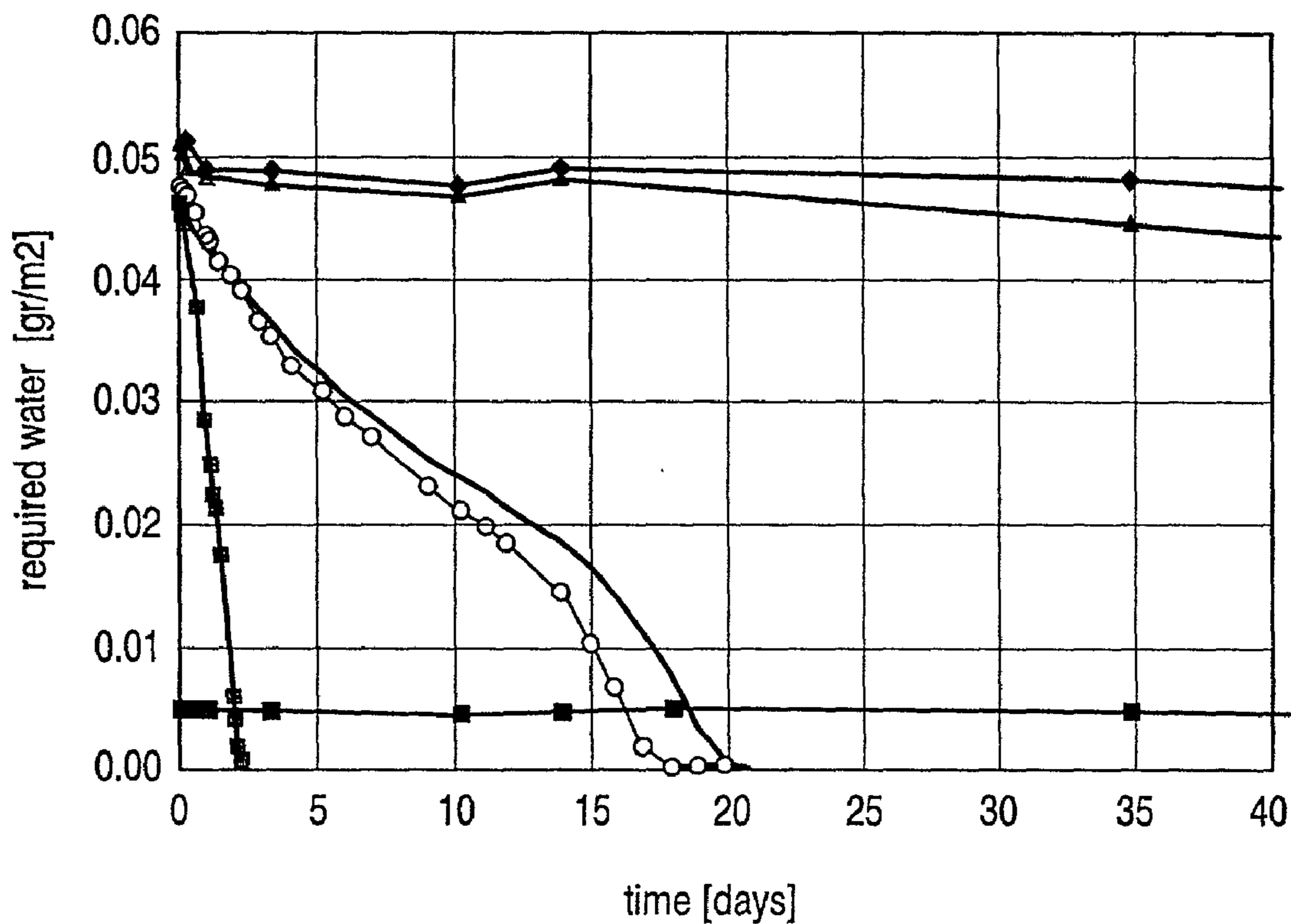

FIG. 6

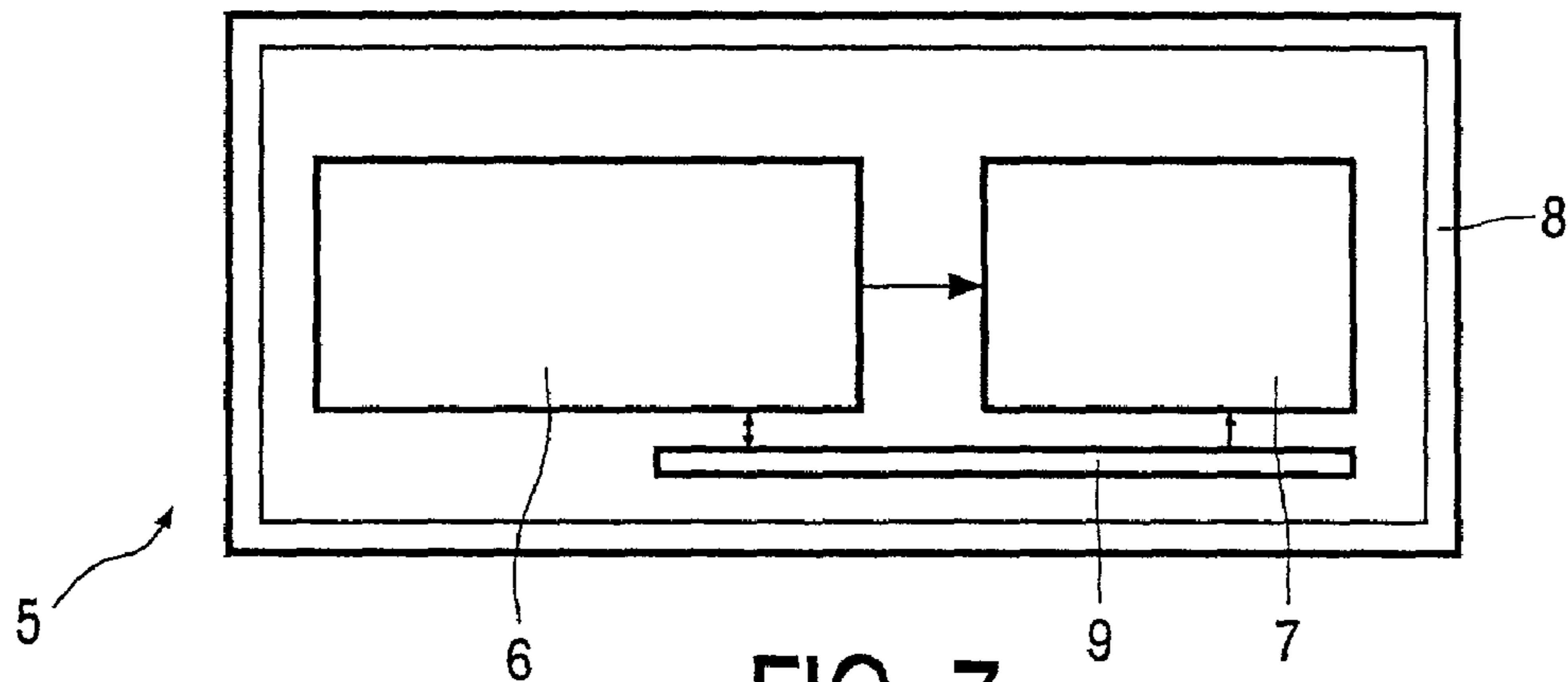

FIG. 7

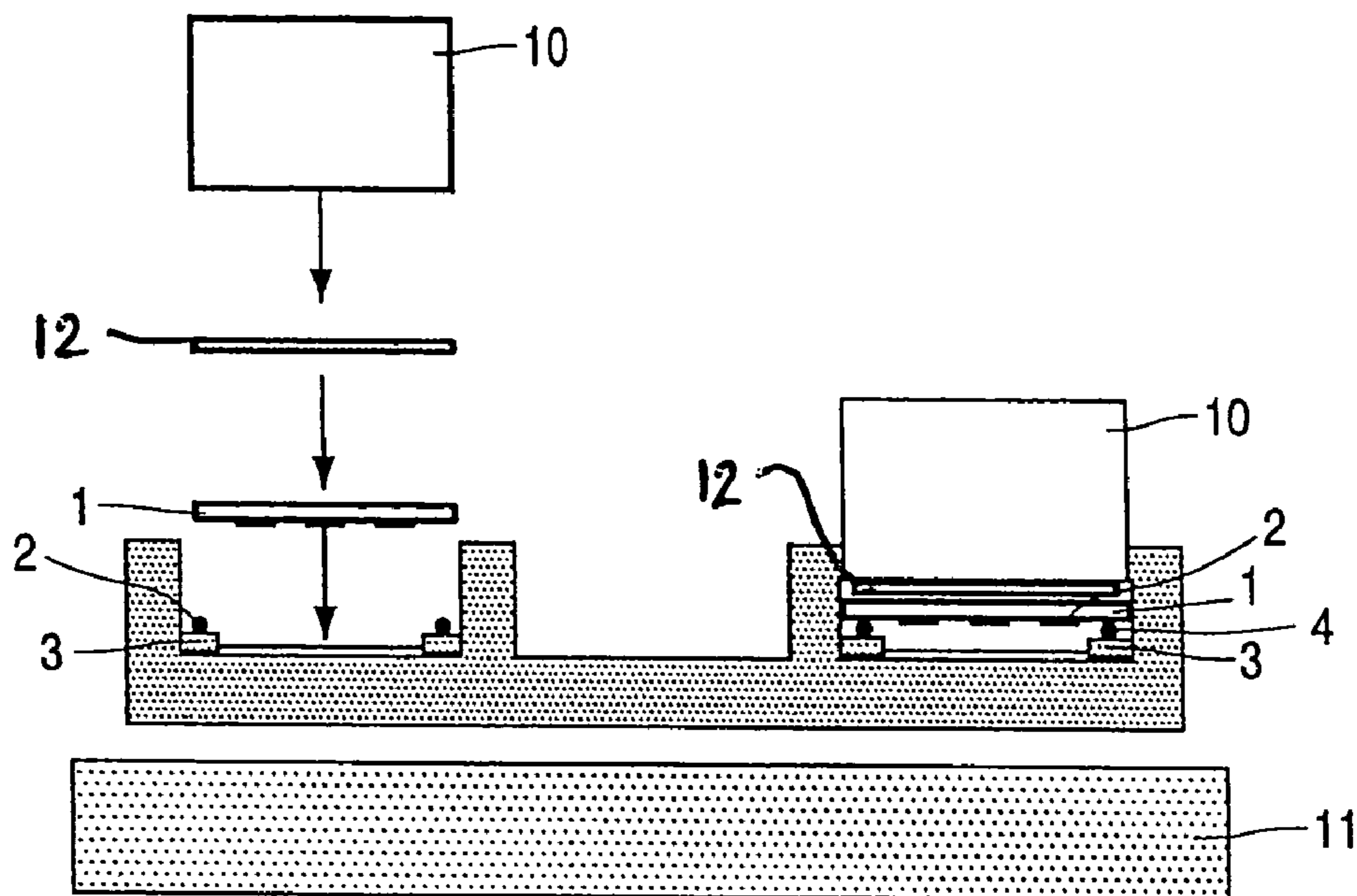

FIG. 8

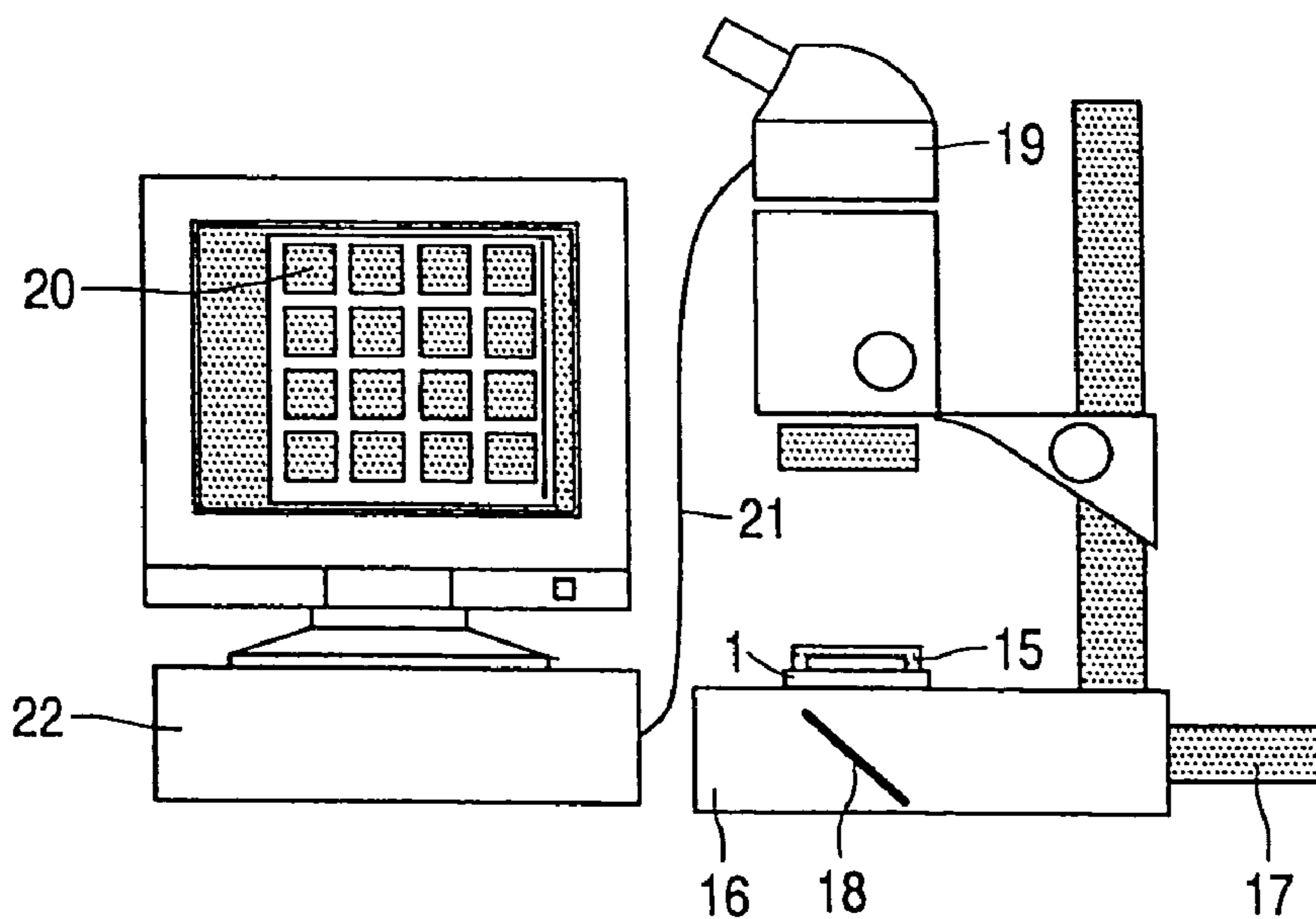

FIG. 9

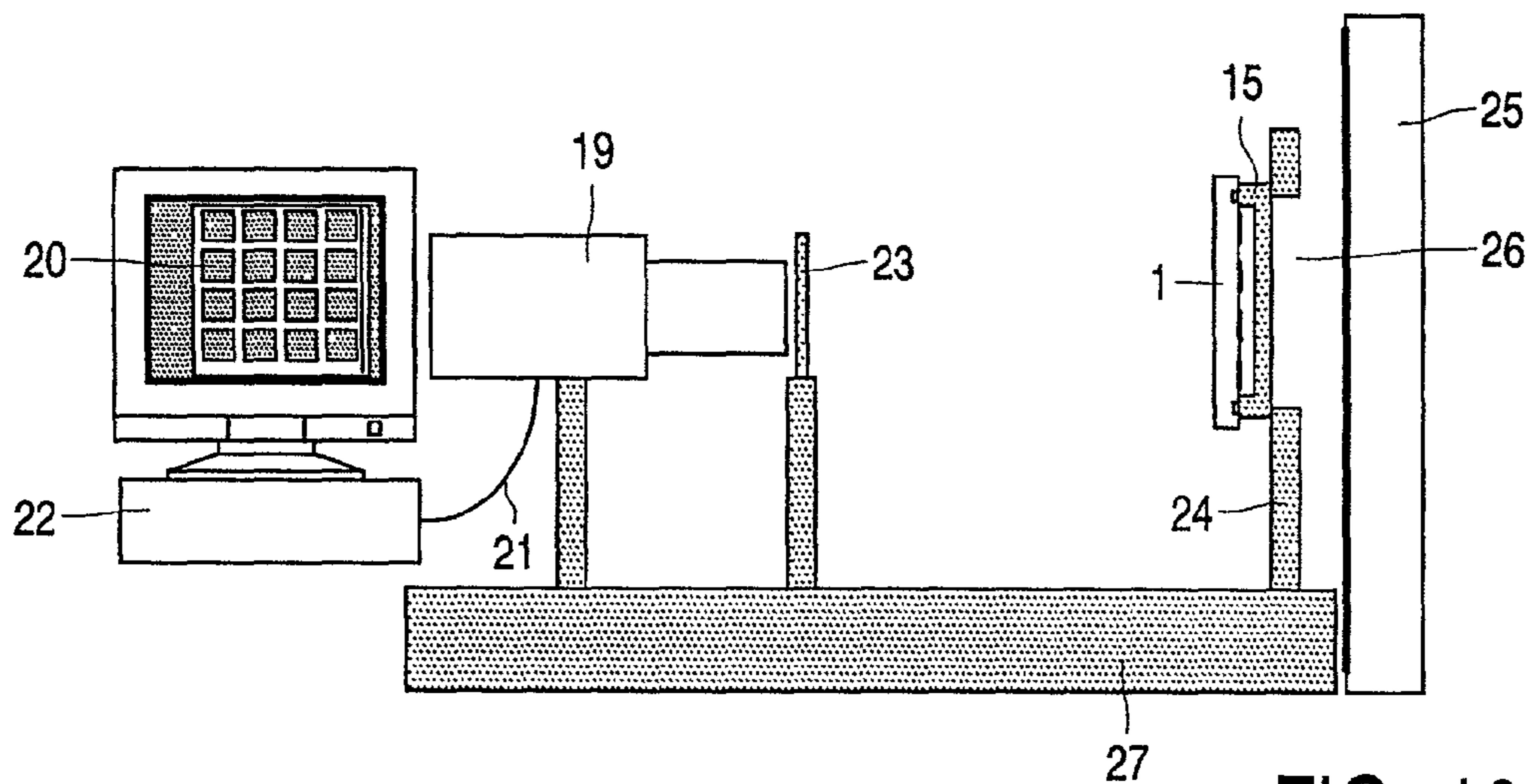

FIG. 10

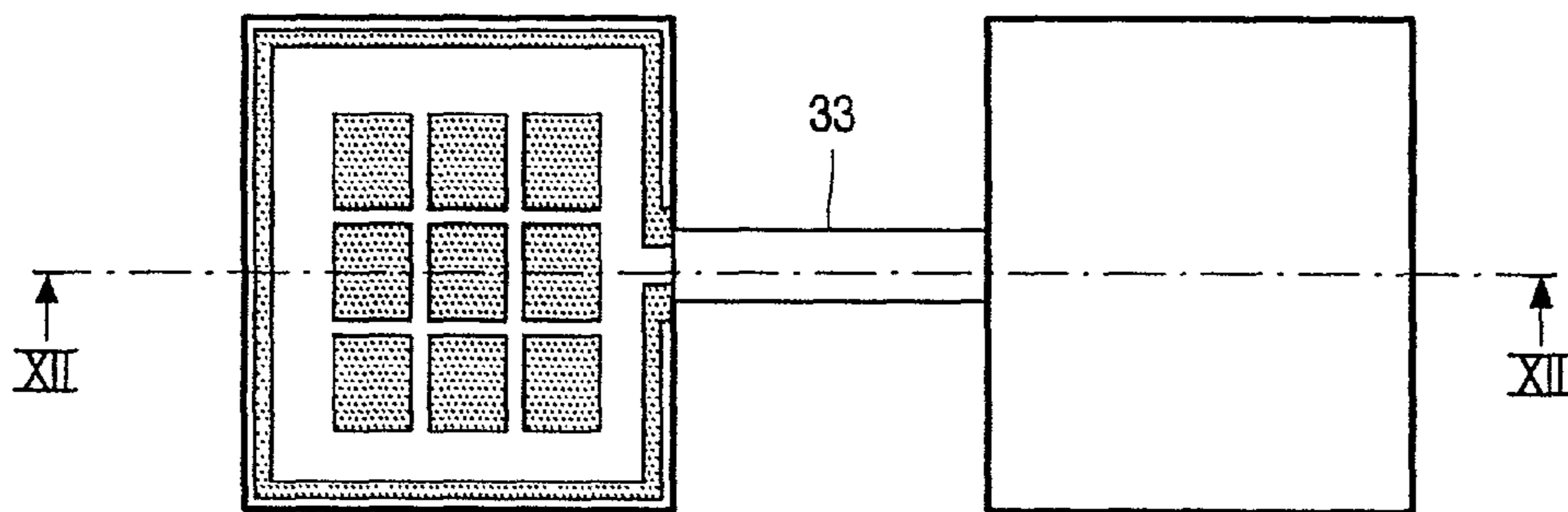

FIG. 11

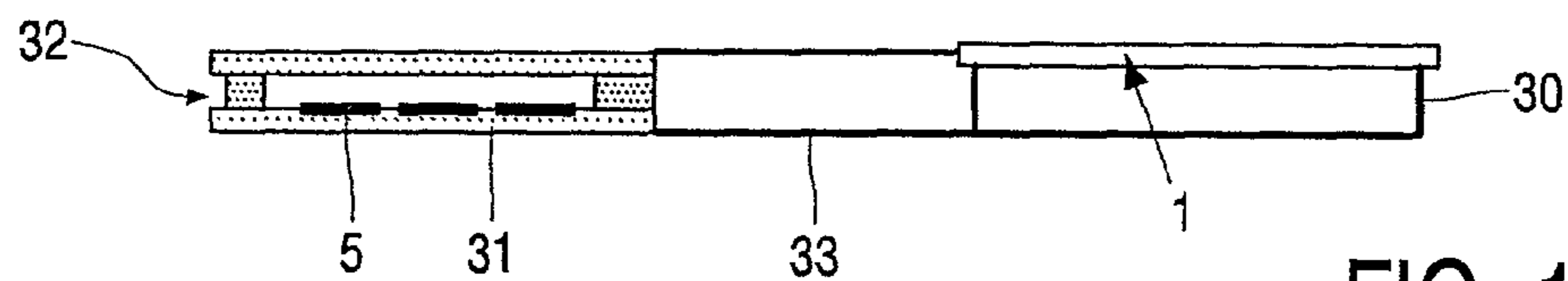

FIG. 12

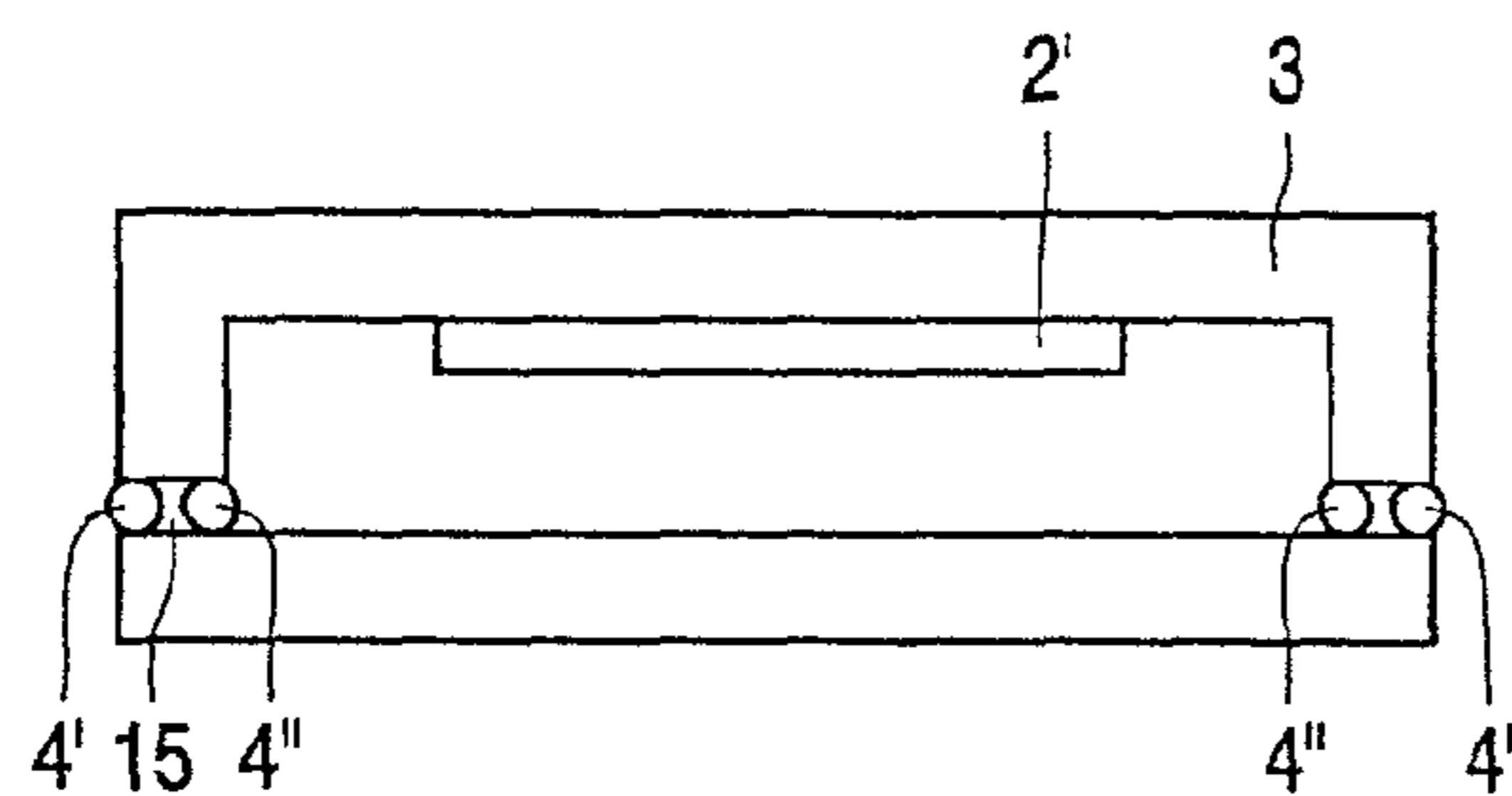

FIG. 13

1

**METHOD FOR MEASURING A
PERMEATION RATE, A TEST AND AN
APPARATUS FOR MEASURING AND
TESTING**

The invention relates to a method for measuring the permeation rate of a substrate, especially a flexible substrate such as a polymer (plastic) substrate for use in liquid crystal display devices, polyLED and other (organic) LED display devices. Especially the combination of polymer (plastic) substrates and (organic) LED devices is very attractive because all materials are flexible and the LED devices have excellent viewing angle properties.

However the electroluminescent organic materials are easily oxidized and react with water. For the cathode material usually reactive metals are used, which degrade even faster. For this reason in the state of the art glass is used as a substrate, which is highly impermeable. The main concern related to permeability here resides in the permeation rate of the seal line. In LCD's the water may react with the liquid crystal material.

Although commercial test systems for measuring the permeation rate of a substrate are available from firms like Mocon (Modern Controls), these are limited to lower limits of 10^{-3} g/m²/day for water and 10^{-3} cc/m²/day/bar for oxygen (at standard temperature and pressure). For plastic substrates to be used in liquid crystal display devices and (organic) LED display devices this value should be at least a factor of 100 lower. Moreover tests can take as long as a week, which is unacceptable in a production environment. The same holds for testing a (semi) finished product.

The invention has as its purpose to solve one or more of these problems To this end it provides a method for measuring a permeation rate, a test method and an apparatus for measuring and testing in which permeation rates as low as 10^{-5} g/m²/day for water or even lower can be measured.

To this end a method according to the invention comprises the steps of

- a) applying a layer of a reactive material to a first side of the substrate in an substantially inert atmosphere
- b) positioning said first side of the substrate within a substantially hermetically sealed environment
- c) exposing the other side of the substrate to an environment containing compounds which react with the reactive material and
- d) comparing the light reflectivity or the light absorption of the layer of reactive material with a calibration value.

The invention is based on the insight that because of e.g. oxidation due to the presence of water and oxygen a reactive material like barium or calcium evolves to an increasingly transparent layer. The transmission or reflection characteristics of the layer can be measured and for instance by storing successive measurements (e.g. CCD images) image analysis, like grey value determination, can be used to determine the thickness of the residual metal layer, which is related to the amount of absorbed compounds, especially water. So these transmission or reflection characteristics are directly related to the permeation rate.

The method according to the invention has the advantages of faster testing. Moreover it provides a greater sensitivity at least in the testing of water. permeability. Also it is more efficient than the existing test methods and the test apparatus can be more flexible.

In certain cases, e.g. when a substantially impermeable substrate (metal or glass) is tested, permeability of a seal or a sealing rim on the substrate may determine the permeation rate. It will be clear that in this case in the claims "substrate"

2

is meant to comprise said seal or a sealing rim. To prevent the permeability testing to be influenced by the permeability of a seal or a sealing rim a sealing rim having more walls is used if necessary. Providing a getter in a double walled seal can prevent further sensibility to penetration through said walls. The reactive material used for the test can be used as getter when applied between the two seal rings.

In a test method according to the invention at least one sample substrate is tested with said method and discriminating between batches to have them pass or not pass the test is based on a threshold value of the permeation rate. The threshold value may either be a mean value or be an extreme value of the permeation rate within a batch.

- An apparatus according to the invention comprises
- a) a first chamber in which an substantially inert atmosphere can be generated
 - b) means for introducing a reactive material into said chamber
 - c) means for positioning said first side of the substrate within a substantially hermetically sealed environment
 - d) means for exposing the hermetically sealed environment to compounds which react with the reactive material
 - e) means for comparing the light reflectivity or the light absorption of the reactive material with a calibration value
- It appears that the test method on the other hand can be used for testing the permeability of encapsulations, like seals, lids or measurement capsules.

In practice the different steps will be divided over several sub-apparatuses.

These and other aspects of the invention will be discussed in more detail with reference to several embodiments and the drawings in which

FIG. 1 shows a plane view of a sample substrate within a substantially hermetically sealed environment

FIG. 2 shows a cross section along line II—II in FIG. 1.

FIG. 3 shows transmission curves for a CaO/Ca layer on glass for different wavelengths as a function of the layer thickness,

FIG. 4 shows transmission curves for a CaO/Ca layer on glass for different values of the layer thickness as a function of the wavelength,

FIG. 5 shows transmission curves for a CaO/Ca layer on glass for $\lambda=500$ nm as a function of the layer thickness for different values of the original layer thickness,

FIG. 6 shows the results of some sample tests.

FIG. 7 shows a schematic embodiment of a measuring and testing equipment for measuring or testing the permeation rate.

FIG. 8 shows means for obtaining a sample substrate within a substantially hermetically sealed environment,

FIGS. 9 and 10 show embodiments of devices for measuring the light reflectivity or the light absorption of a layer,

FIG. 11 shows another embodiment according to the invention, while

FIG. 12 shows a cross section along line XII—XII in FIG. 11 and

FIG. 13 shows another example of using the invention.

Figures are not drawn to scale while in general like reference numerals identify like elements.

The principle of the method for measuring the permeation rate of a substrate will be discussed with reference to FIGS. 1–6. A thin layer 2 (e.g. 100 nm) of a reactive material, in this example Ca, is deposited in an substantially inert atmosphere on a substrate 1 to be tested. In this example the Ca is deposited in a pattern of 16 squares. A glass sheet or lid 3 is interconnected to the substrate 1 along its edge via a substantially hermetic seal 4, e.g. a glue, a metal like In or

3

a solder metal to form a closed box. Alternatively the Ca layer may be covered by a hermetic coating (silicon nitride, silicon oxide or a metal layer (to provide a hermetic sealing of said layer.

Water or oxygen permeating into the box reacts with Ca according to the reactions



or



Due to these reactions the amount of calcium decreases leading to a smaller metal layer thickness (or a reduced area of the deposited material). This also implies that the deposited layer becomes transparent, the transparency or transmission being an indicator for the amount of water or oxygen having diffused into the box.

FIG. 3 shows calculated transmission curves for a CaO/Ca layer on glass for different wavelengths, viz. 500 nm (curve a), 600 nm (curve b), 700 nm (curve c), 800 nm (curve d) and the substrate 1 (curve e), as a function of the layer thickness. Since the layer thickness is in the order of the wavelength of light the transmission or reflection of the layer the transmission and reflection of the layers depend strongly on the wavelength too. This is shown by way of example in FIG. 4, which shows calculated transmission curves for a CaO/Ca layer on glass for different values of the layer, viz. 0 nm (curve a), 10 nm (curve b), 20 nm (curve c), 40 nm (curve d), 60 nm (curve e), 80 nm (curve f) and 100 nm (curve g), as a function of the wavelength.

FIG. 5 shows transmission curves for a CaO/Ca layer on glass at a fixed wavelength as a function of the layer thickness for different values of the original layer thickness. In FIG. 5 this is shown for $\lambda=500$ nm for layers having an original layer thickness of 90 nm (curve d), 100 nm (curve e), 120 nm (curve g), and 150 nm (curve i).

These data can be used to determine a calibration curve to be used during measuring and testing dependent on the wavelength used and the original layer thickness. Said curve can be stored as a function relating the transmission or reflection to a certain layer thickness. The intermediate values of transmission or reflection can be measured as (average) grey-values by means of a CCD device or a digital camera. To obtain reference values a black border is introduced in the device of FIG. 1 to measure the transmission of an average black area; the reference value for average white is determined by measuring the transmission of the transmissive area between the squares of deposited Ca.

Since the thickness of the original Ca layer as well as the total area is known a (difference in) grey-value can be attributed to a (difference in) layer thickness. The total amount of Ca having reacted according to reactions (1), (2) and (3) and the amount of water required to convert the residual calcium volume is known. This is shown for a number of samples in FIG. 6, which shows the residual calcium volume as a function of time. The difference between two moments of measuring determines the difference in grey-values between said two moments of measuring. This is shown for a number of samples (substrates of different kinds of substrate materials) in FIG. 6. The slope of a curve is a measure for the permeation rate.

The sample of curve c shows a permeation rate of about 2.10^{-3} g/m²/day for water, whereas the sample of curves e and f show permeation rates of about 2.10^{-4} g/m²/day for water and sample of curve d shows a permeation rate of

4

< 10^{-5} g/m²/day for water. This shows that the method can measure permeation rates up to a factor 100 or more better than existing equipment. Similar experiments show that the method is suitable for testing oxygen permeability to a level of 10^{-2} cc/m²/day/bar or lower.

FIG. 7 shows a measuring and testing equipment 5 for measuring or testing the permeation rate in which means 6 for obtaining a sample substrate and a device 7 for measuring the light reflectivity or the light absorption of a layer are both present within the same substantially hermetically sealed environment, for example a glove box 8 with manipulating means 9. In another embodiment the means 6 for obtaining a sample substrate and the device 7 for measuring the light reflectivity or the light absorption of a layer may be placed in different glove boxes 8, provided the samples can be transported from the means 6 for obtaining a sample substrate to the device 7 for measuring in a substantially hermetically sealed environment.

A sample substrate is obtained by calcium deposition of a predetermined thickness, e.g. 100 nm, using a mask (see FIG. 8, in this example a 4x4 array of 6 mm² is used). Calcium covered samples can be stored in the glove box, but preferably the test cells are manufactured as soon as possible after deposition together with reference cells if any.

The substrate 1 is placed upside down on the lid 3, which has been provided with a seal 4. To obtain a good sealing a copper weight 10 is placed on top of the assembly, while the whole assembly is heated on a heating plate 11 at 100° C. for 15 minutes. To prevent the substrate from sticking to the copper plate a Teflon spacer 12 may be inserted temporarily. It will be clear that the above figures are just an example and may be different dependent on the materials used.

FIG. 9 shows in more detail a possible device 7 for measuring the light transmission of a CaO/Ca layer on glass in a sample as prepared with reference to FIG. 8, which sample is exposed to an H₂O atmosphere. The sample 15 is placed on top of an optical system 16, which is illuminated by means of fiber illumination via a fiber 17. The light passes the sample via a mirror 18 and digital images are taken by means of a digital camera 19. The images 20 may be taken on a continuous base and are stored via interconnections 21 in a computer or dataprocessing equipment 22.

FIG. 10 shows another implementation in which the transmission is measured for a single colour by introducing a colour filter 23. The sample 15 is now vertically placed within a hole 26 in a support 24 and is illuminated by means of a backlight 25. The camera 19 is in this example a CCD camera optimized for the colour used. The camera 19, a colour filter 23 and the support 24 are placed on an optical rail 27.

Image processing of the obtained grey-values can be performed in different ways. As mentioned above, a calibration curve can be determined in advance, as is shown with reference to FIGS. 3-5. Other methods such as deconvolution of spectra are also possible.

It is clear from the above that different steps of the method preferably are performed in dedicated sub-apparatuses, such as a first sub-apparatus for deposition, a second one for exposing to environmental conditions and a third one for measuring, although some of these may be combined e.g. in the case of continuous monitoring of the Ca layer, which may be useful when testing is performed at elevated temperatures.

FIGS. 11 and 12 finally show another implementation in which a (non-transparent) substrate 1 is sealed to a housing 30, comparable to the lid 3 in FIGS. 1, 2, whereas the Ca pattern 3 now has been deposited on a transmissive substrate

5

31 of a measuring cell 32. To start measuring or testing the housing 30 is interconnected to the measuring cell 32 via a glass tube 33. Water or oxygen permeating into the housing 30 via substrate 1 passes the tube 33 and reacts with Ca. The Ca layer is affected in a similar method as mentioned above. 5 The transparency of the layer is measured again for example in a similar method as shown with respect to FIGS. 9, 10 to determine the permeation rate.

In some cases, if the substrates have very small permeability the leaking of the seal sets the lower boundary of the sensitivity of the measurement method. 10

In this case the seal is split in two walls (an outer wall 4' and an inner wall 4", as shown in FIG. 13 for a measurement to be discussed below). Between these two walls a cavity is created where a getter (desiccant) 15 is placed. If for the desiccant the same reactive material that as for the measurement, is chosen they can be applied in the same process step. 15

In case of the permeability test cells, now it is possible to use a desiccant to absorb the leaking water and oxygen through the seal. Since, when using Ca as an indicative layer 2 the Ca in the main cavity also acts as a getter, substantially no concentration gradient is present over the inner seal, so there is no water and oxygen transport through this seal. 20

The making of two chambers in the seal does not have to be an additional step, e.g. when using a glass lid, where the cavities are made by powderblasting. 25

It should be noted that the above-mentioned embodiments illustrate rather than limit the invention, and that those skilled in the art will be able to design many alternative embodiments without departing from the scope of the appended claims. In this respect it should be noted that also the measure of reflection of the layers is an indication for its thickness and can be used to determine the permeation rate. Another reactive material like barium or sodium can be used in stead of calcium. 30

An example is gadolinium which is very suitable for the testing of permeation of hydrogen. In the method according to the invention now the layer 2 comprises a stack of metals, e.g. Gd/Pd or Mg_xGd_{1-x}/Pd . The reactive compound reacts well with diffusing hydrogen. The reaction leads to a change in the appearance of the layer again. For hydrogen detection a catalyst might be necessary. This means that instead of a single Ca-layer a stack of two layers is deposited, for instance 100 nmGd+10 nm Pd. For a surface area of 1 cm² this represents $5 \cdot 10^{-7}$ mole Gd. This silvery Gd reacts to dark blue GdH₂. The change in colour is measured again as a change in reflection (or transmission. If $5 \cdot 10^{-7}$ mole H₂ reacts in 1 day this represents a hydrogen flux of 10^{-2} g H₂ per day per m². Hydrogen fluxes between 10^{-4} and 10^2 g H₂ per day per m² can be measured with this set up. 40

Since in normal ambient hydrogen is present at extremely low concentrations all work can be carried out in normal ambient. The Pd layer not only acts as a catalyst but also protects the Gd from corrosion in air. The insensitivity of the indicator metal layer makes this method very suitable for making half fabricates for the metod or for an apparatus according to the invention, like ready-to-use cover lids 3 (with indicator metal layer 2', See FIG. 13) or measuring cells 32. 45

It goes without saying that the method is also applicable for testing substrates and encapsulations outside the display applications, for example testing on a sample base of PolyLed/OLED lids and OLED seal materials, IC lids or in medical applications. 50

In the claims, any reference signs placed between parentheses shall not be construed as limiting the claim. The word

6

“comprising” does not exclude the presence of other elements or steps than those listed in a claim.

What is claimed is:

1. A method for measuring the permeation rate of a substrate comprising:

- a) positioning a substrate within a substantially hermetically sealed environment;
- b) applying reactive material to a first side of the substrate in a substantially inert atmosphere;
- c) exposing the ether side of the substrate to an environment containing compounds which react with the reactive material; and
- d) comparing the light reflectivity or the light absorption of the layer of reactive material with a calibration value. 15

2. A method for measuring the permeation rate of a substrate comprising:

- applying a layer of a reactive material to a first side of the substrate in a substantially inert atmosphere;
- positioning said first side of the substrate within a substantially hermetically sealed environment;
- exposing the other side of the substrate to an environment containing compounds which react with the reactive material; and
- comparing the light reflectivity or the light absorption of the layer of reactive material with a calibration value, in which the compounds which react with the reactive material belong to the group of water, oxygen and hydrogen. 20

3. A method for testing a set of substrates from a batch for permeability, said method comprising:

- a) measuring the permeation rate of at least one sample substrate with a method including:
 - applying a layer of a reactive material to a first side of the substrate in a substantially inert atmosphere;
 - positioning said first side of the substrate within a substantially hermetically sealed environment;
 - exposing the other side of the substrate to an environment containing compounds which react with the reactive material; and
 - comparing the light reflectivity or the light absorption of the layer of reactive material with a calibration value, and

- b) discriminating between batches to have them pass or not pass the test based on a threshold value of the permeation rate. 25

4. A method according to claim 3 in which the threshold value is determined as either a mean value or an extreme value of the permeation rates within a batch.

5. A method according to claim 3 in which the threshold value is at most 10^{-4} g/m²/day for water.

6. A method according to claim 5 in which the threshold value is at most 10^{-5} g/m²/day for water.

7. A method for measuring the permeation rate of a substrate comprising:

- applying a layer of a reactive material to a first side of the substrate in a substantially inert atmosphere;
- positioning said first side of the substrate within a substantially hermetically sealed environment in which the hermetic seal includes at least two walls;
- exposing the other side of the substrate to an environment containing compounds which react with the reactive material; and
- comparing the light reflectivity or the light absorption of the layer of reactive material with a calibration value, in which a getter is provided in the seal. 30

7

8. A method for measuring the permeation rate of a substrate comprising:

applying a layer of a reactive material to a first side of the substrate in a substantially inert atmosphere;

positioning said first side of the substrate within a substantially hermetically sealed environment in which the hermetic seal includes at least two walls;

exposing the other side of the substrate to an environment containing compounds which react with the reactive material; and

comparing the light reflectivity or the light absorption of the layer of reactive material with a calibration value, in which the seal comprises the reactive material.

9. An apparatus for performing a method for measuring the permeation rate of a substrate comprising:

applying a layer of a reactive material to a first side of the substrate in a substantially inert atmosphere;

positioning said first side of the substrate within a substantially hermetically sealed environment;

exposing the other side of the substrate to an environment containing compounds which react with the reactive material; and

comparing the light reflectivity or the light absorption of the layer of reactive material with a calibration value, the apparatus comprising:

a) a first chamber in which a substantially inert atmosphere can be generated;

b) means for introducing a reactive material into said chamber;

c) means for positioning said first side of the substrate within a substantially hermetically sealed environment;

d) means for exposing the hermetically sealed environment to compounds which react with the reactive material; and

e) means for comparing the light reflectivity or the light absorption of the reactive material with a calibration value.

8

10. An apparatus according to claim **9**, comprising:

a first sub-apparatus, said first sub-apparatus including:

a) the first chamber in which the substantially inert atmosphere can be generated;

b) the means for introducing the reactive material into said chamber;

c) the means for positioning said first side of the substrate within the substantially hermetically sealed environment;

a second sub-apparatus comprising the means for exposing the hermetically sealed environment to compounds which react with the reactive material; and

a third sub-apparatus comprising the means for comparing the light reflectivity or the light absorption of the reactive material with the calibration value.

11. An apparatus according to claim **10** in which at least two sub-apparatuses have been combined.

12. An apparatus according to claim **9** which comprises external manipulating means.

13. An apparatus according to claim **9** in which the means for exposing the substantially hermetically sealed environment to compounds which react with the reactive material comprises a closed connection between the first chamber and a second chamber which connection may be opened to start testing.

14. An apparatus according to claim **9** in which the means for comparing the light reflectivity or the light absorption with a calibration value comprise at least a digital camera.

15. An apparatus according to claim **9** in which the means for comparing the light reflectivity or the light absorption with a calibration value comprise means for obtaining a reflection spectrum or an absorption spectrum.

16. An apparatus according to claim **9** in which the means for comparing the light reflectivity or the light absorption with a calibration value further comprise image processing means.

* * * * *