



US006988423B2

(12) **United States Patent**
Bolam et al.

(10) **Patent No.:** **US 6,988,423 B2**
(45) **Date of Patent:** **Jan. 24, 2006**

(54) **UNIVERSAL CONNECTING DEVICE THAT DESIGNATES AN OPERATIONAL MODE**

(75) Inventors: **Kenneth Michael Bolam**, Charlotte, NC (US); **James Arthur Borgen**, Matthews, NC (US)

(73) Assignee: **KCI Licensing, Inc.**, San Antonio, TX (US)

(*) Notice: Subject to any disclaimer, the term of this patent is extended or adjusted under 35 U.S.C. 154(b) by 299 days.

(21) Appl. No.: **09/755,313**

(22) Filed: **Dec. 27, 2000**

(65) **Prior Publication Data**

US 2004/0106884 A1 Jun. 3, 2004

Related U.S. Application Data

(60) Division of application No. 09/103,694, filed on Jun. 29, 1998, now abandoned, which is a continuation-in-part of application No. 08/751,170, filed on Nov. 15, 1996, now Pat. No. 5,951,502, which is a continuation-in-part of application No. 08/223,429, filed on Apr. 5, 1994, now Pat. No. 5,575,762.

(51) **Int. Cl.**
G01N 19/00 (2006.01)

(52) **U.S. Cl.** **73/865.9; 73/1.01; 73/1.22**

(58) **Field of Classification Search** **73/865.9, 73/1.01, 1.22, 431, 1.41, 1.7**

See application file for complete search history.

(56) **References Cited**

U.S. PATENT DOCUMENTS

4,476,706 A * 10/1984 Hadden et al. 73/1.07
5,249,121 A * 9/1993 Baum et al. 606/1

* cited by examiner

Primary Examiner—Hezron Williams

Assistant Examiner—Rodney Frank

(74) *Attorney, Agent, or Firm*—Eric W. Cernyar

(57) **ABSTRACT**

A controller for a gradient sequential compression system is provided for inflating a plurality of inflatable chambers of one or more compression sleeves according to several different modes of operation. A mode of operation may define the number and selection of chambers to be inflated, the pressurization levels, the pressurization time, or the sequence of chamber inflation. To enable the controller to automatically perform a designated mode of operation based on the type of compression sleeve connected, a new and improved connecting device is provided. An indicator on an interface connector associates a predetermined mode of operation with the interface connector. A sensor associated with a complementary connector identifies the mode of operation associated with the interface connector. It is contemplated that the universal connecting device can be used for any type of system, not just controllers for a gradient sequential compression system.

16 Claims, 12 Drawing Sheets

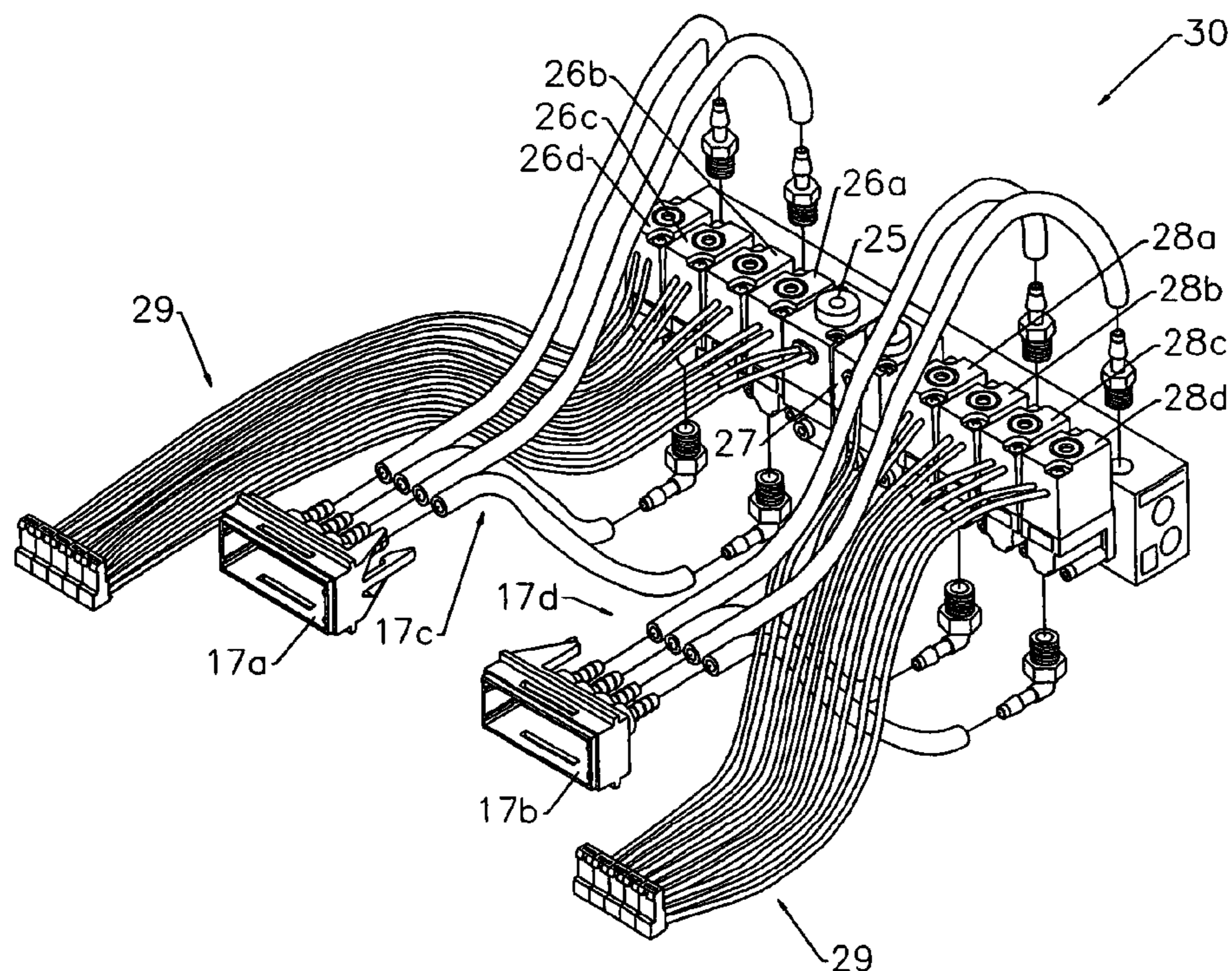

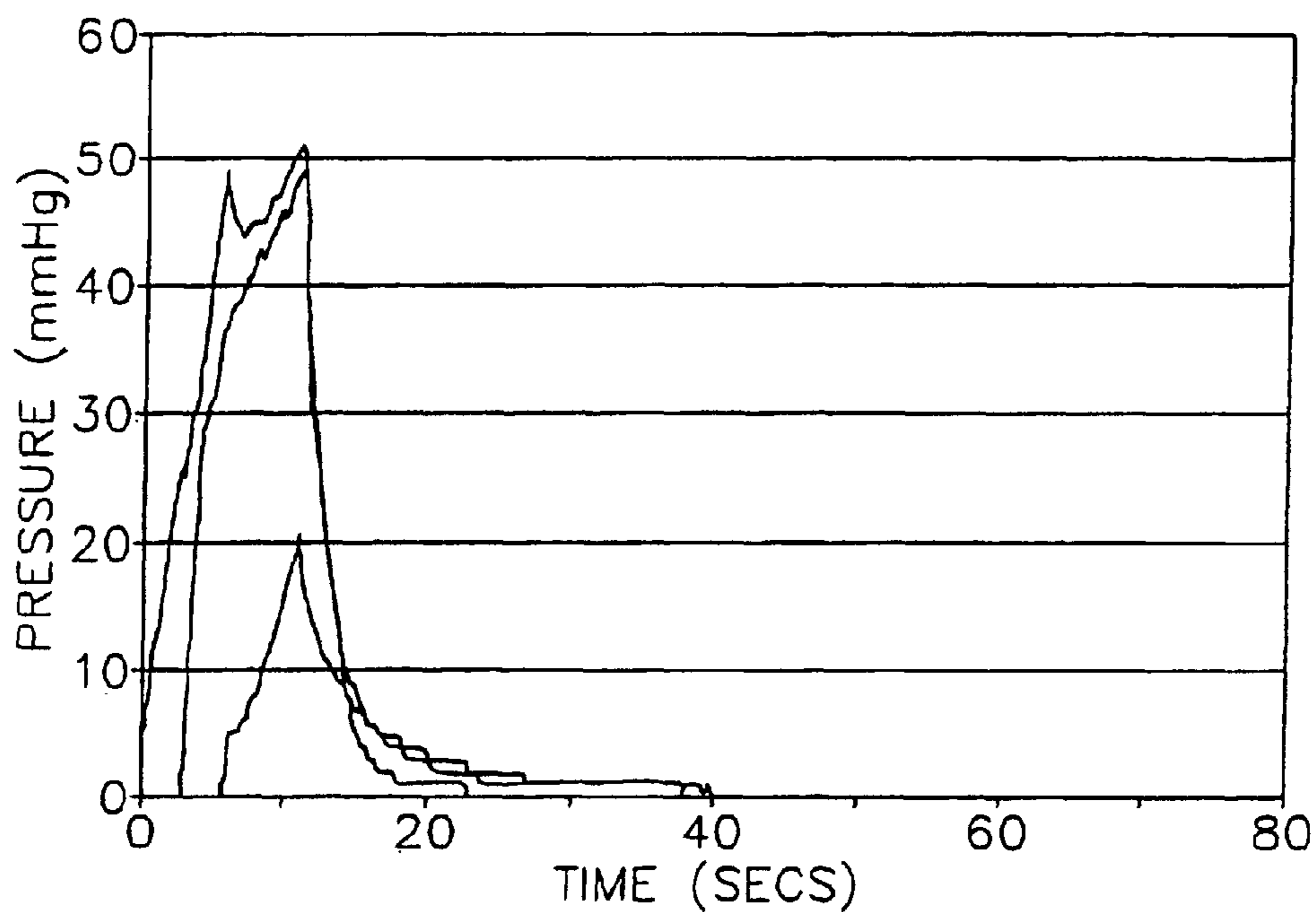

FIG. 1.
(PRIOR ART)

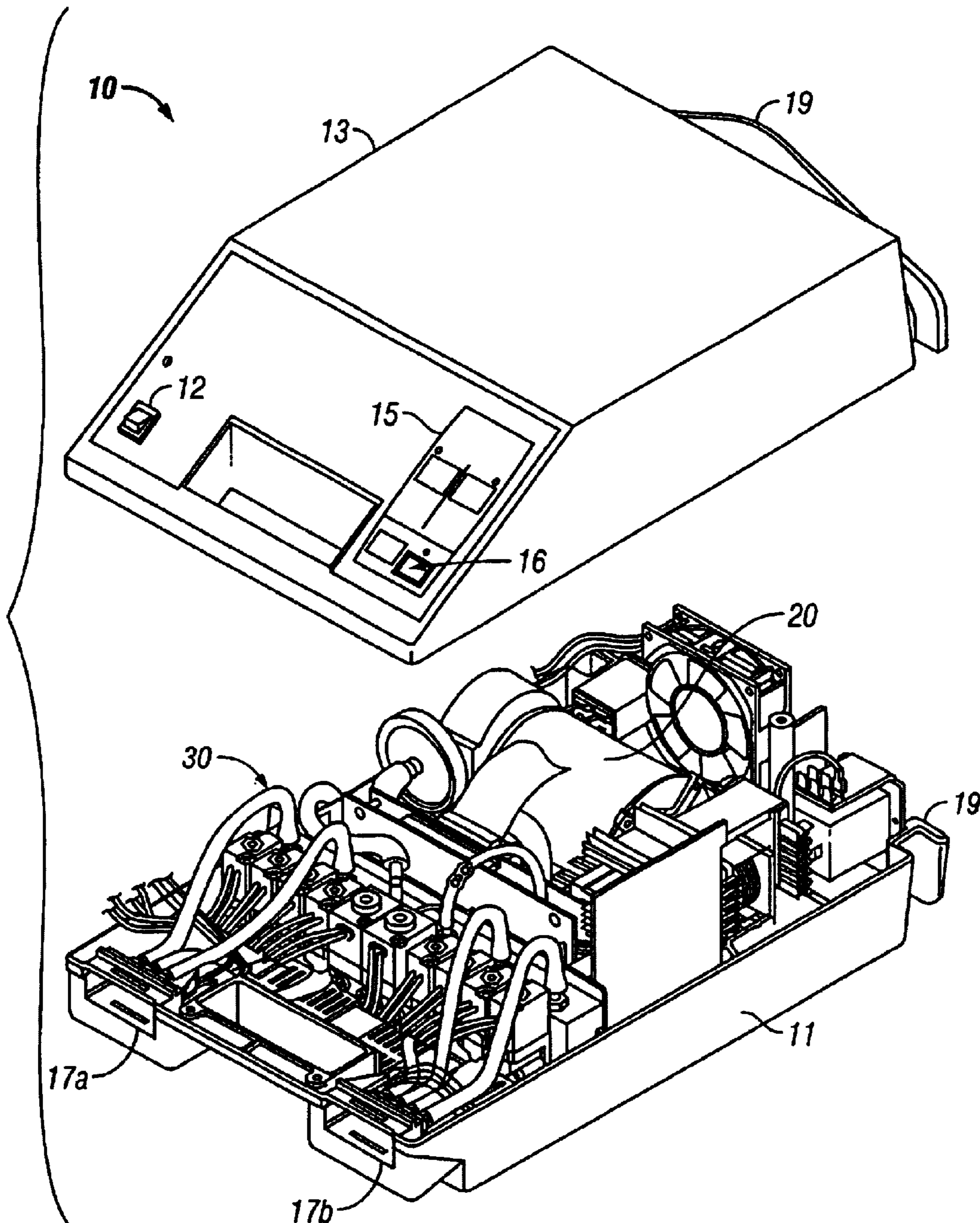

FIG. 2

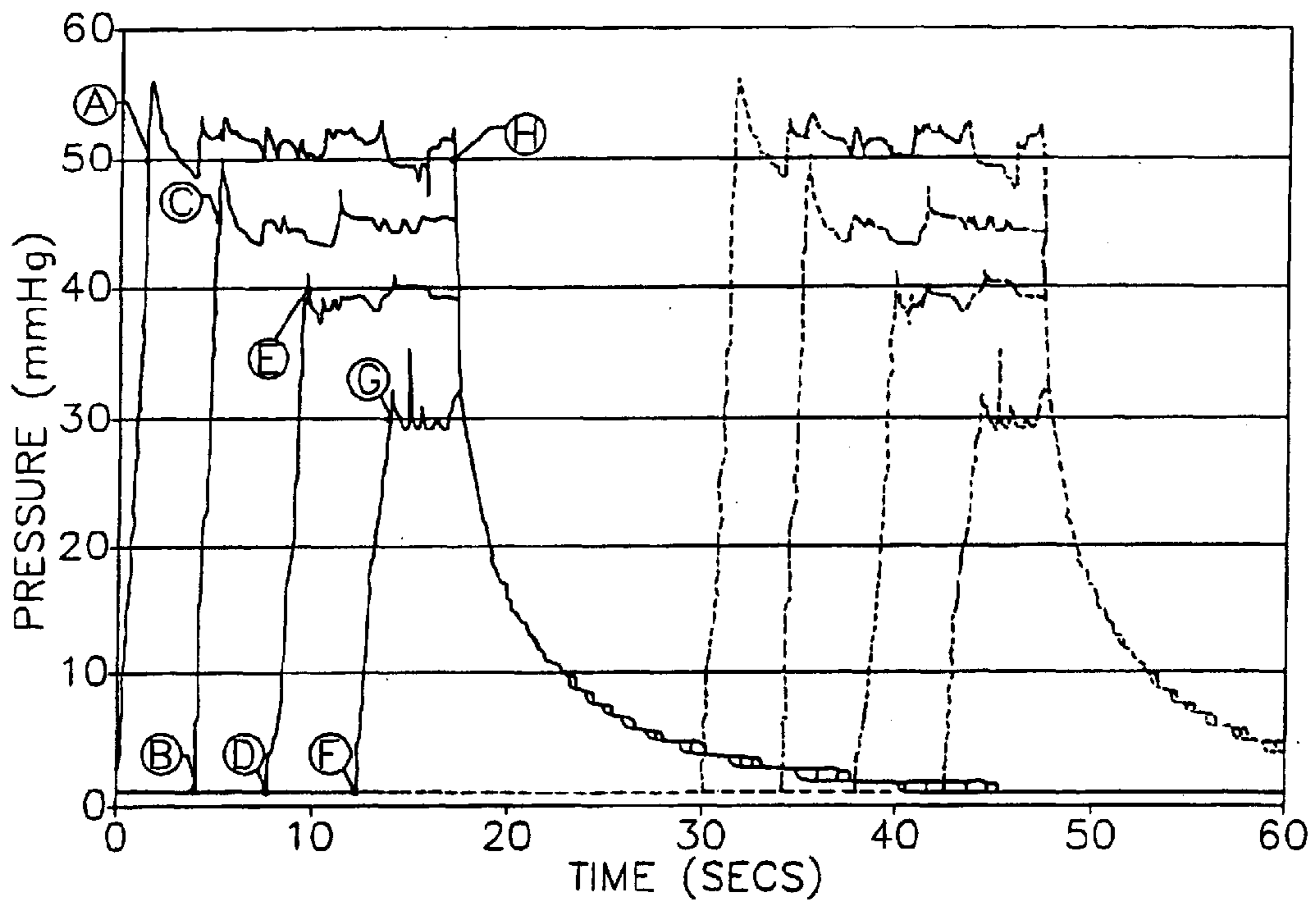

FIG. 3A.

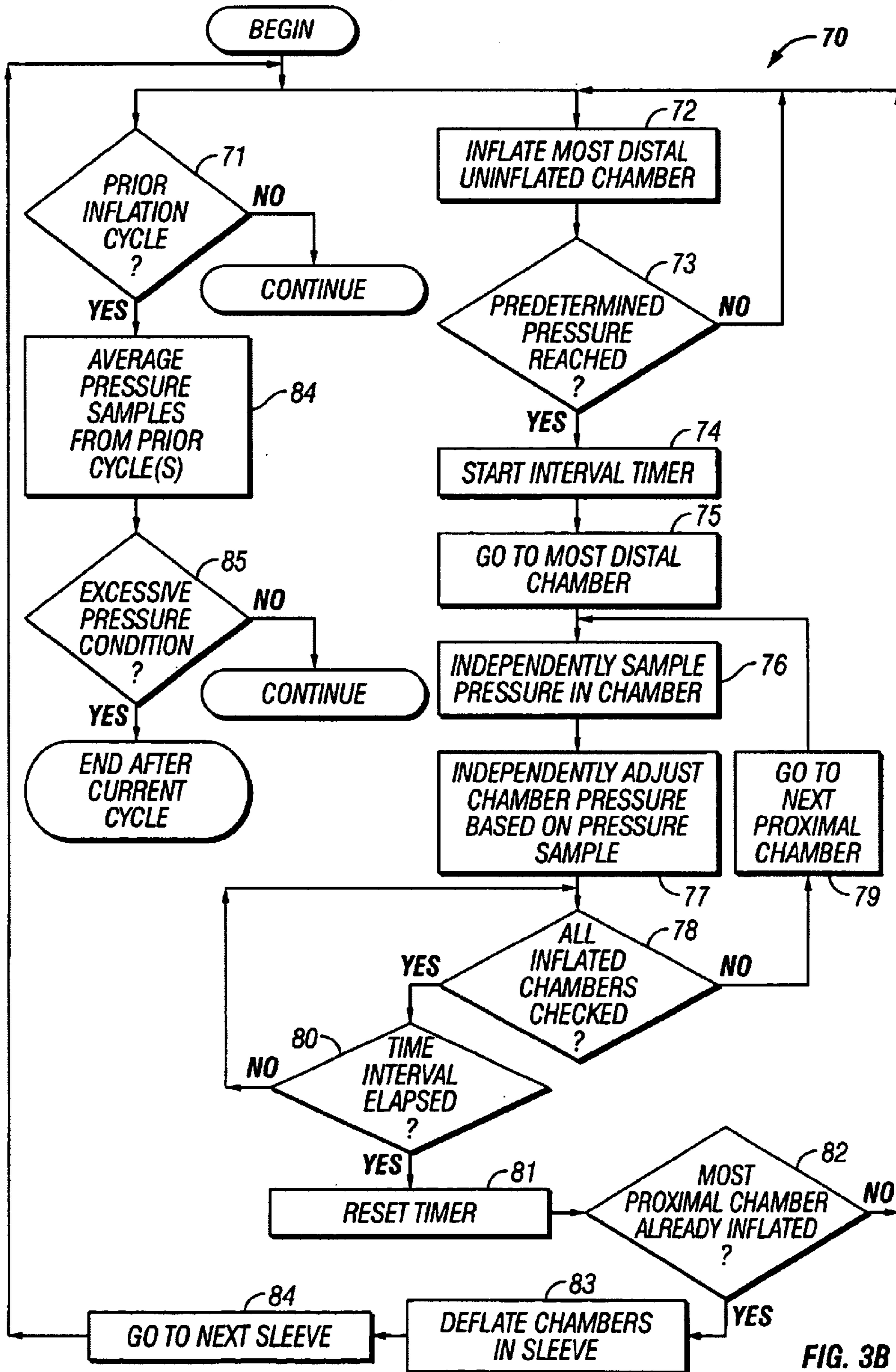

FIG. 3B

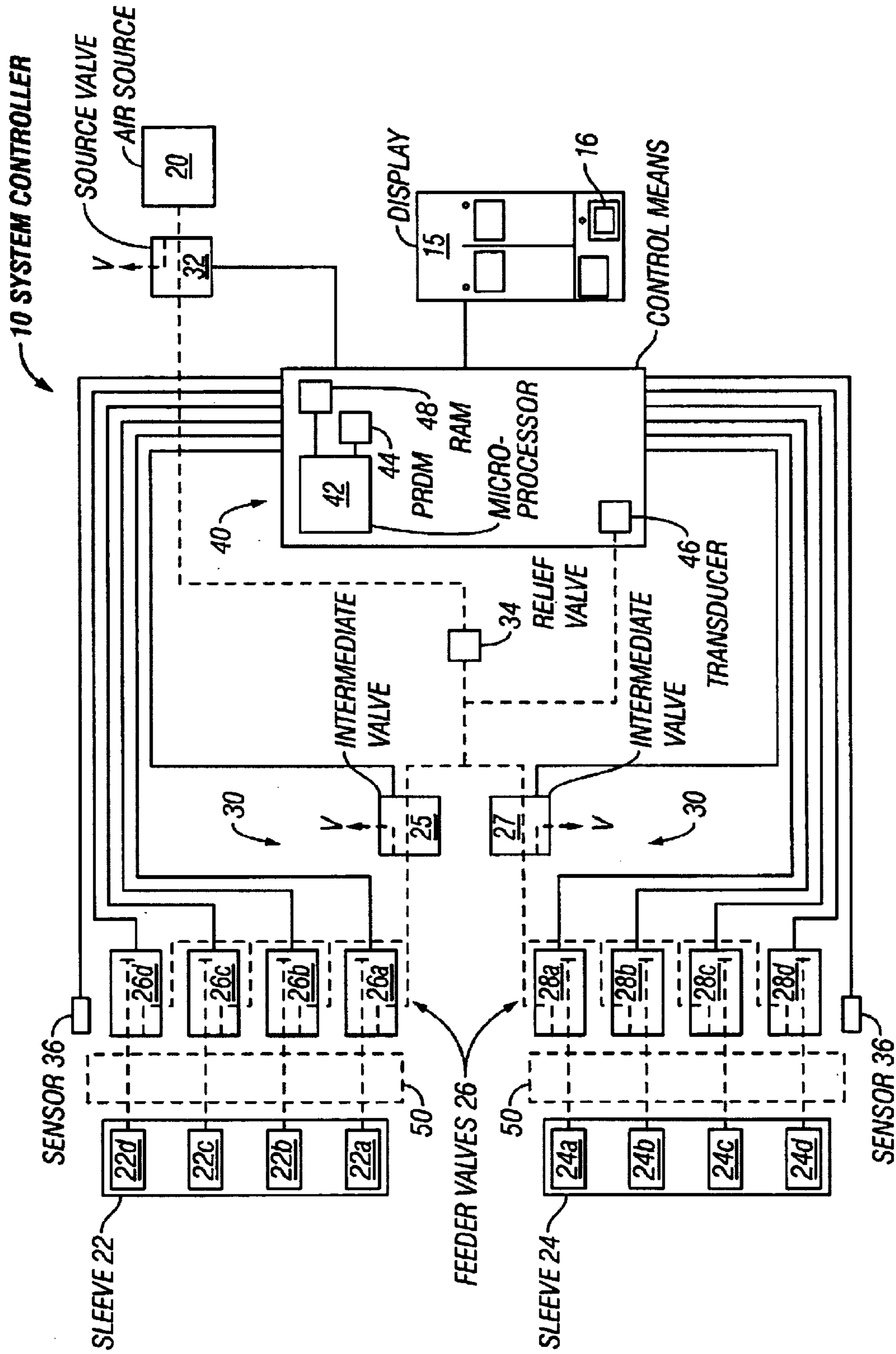

FIG. 4

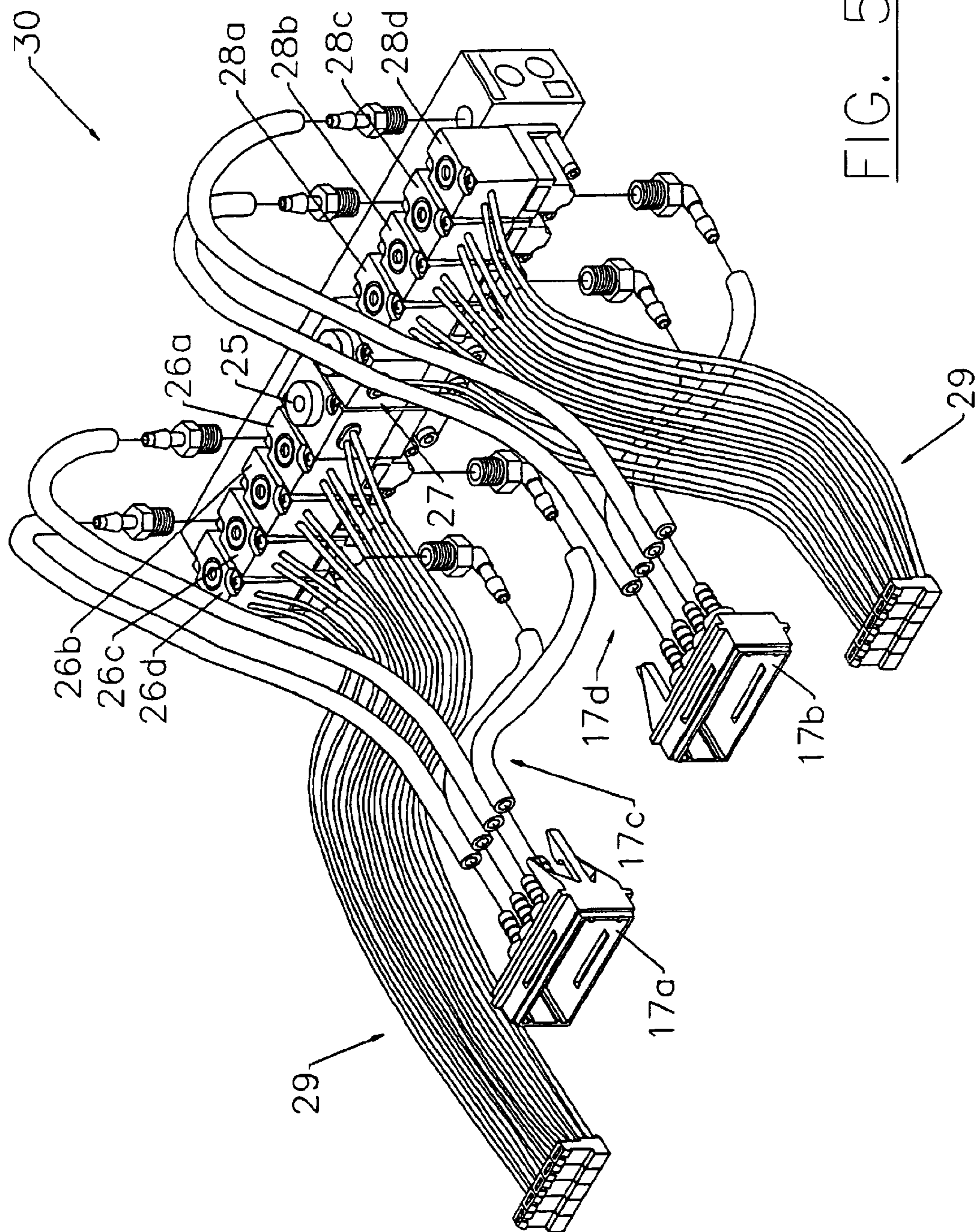

FIG. 5.

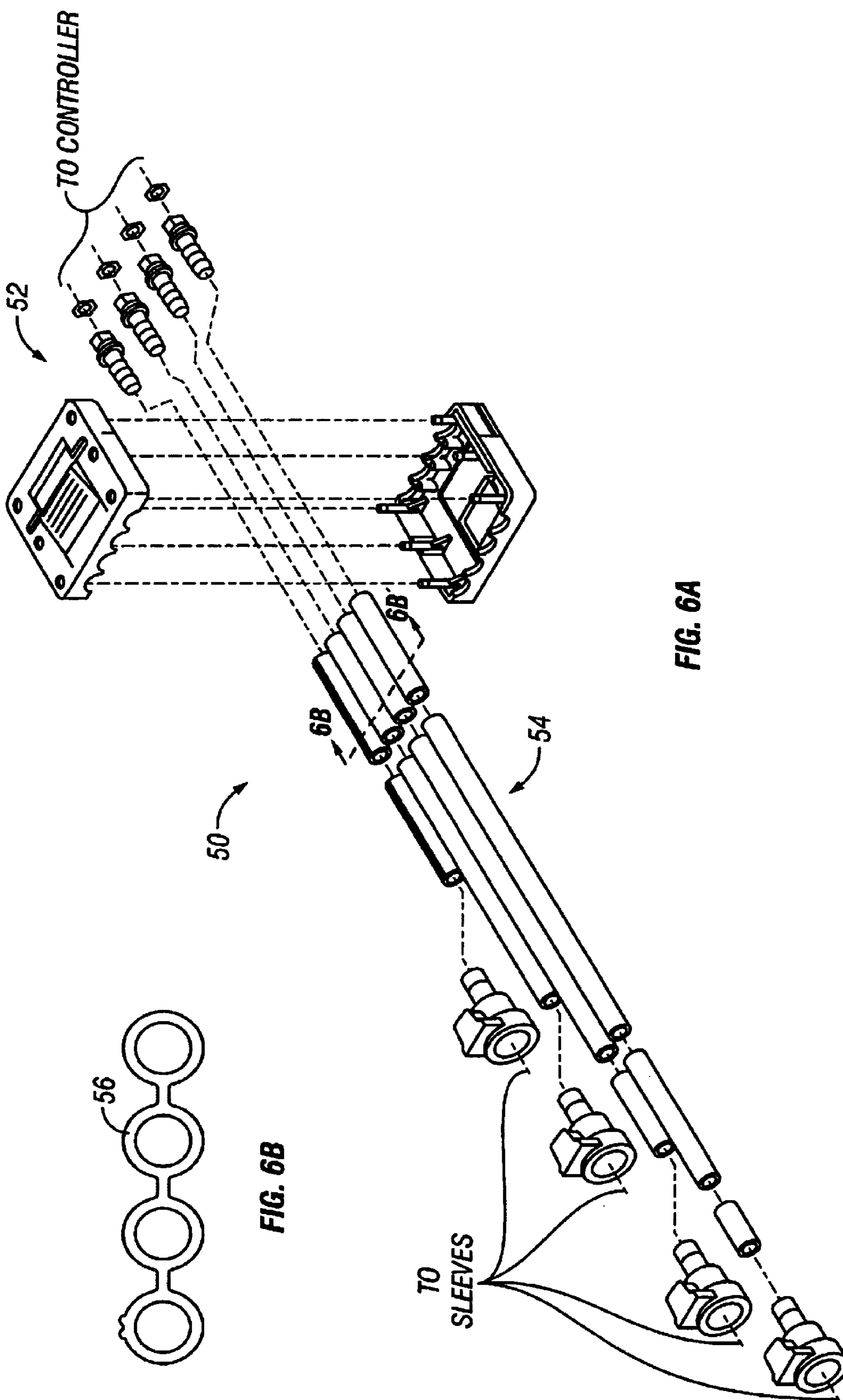

FIG. 6A

FIG. 6B

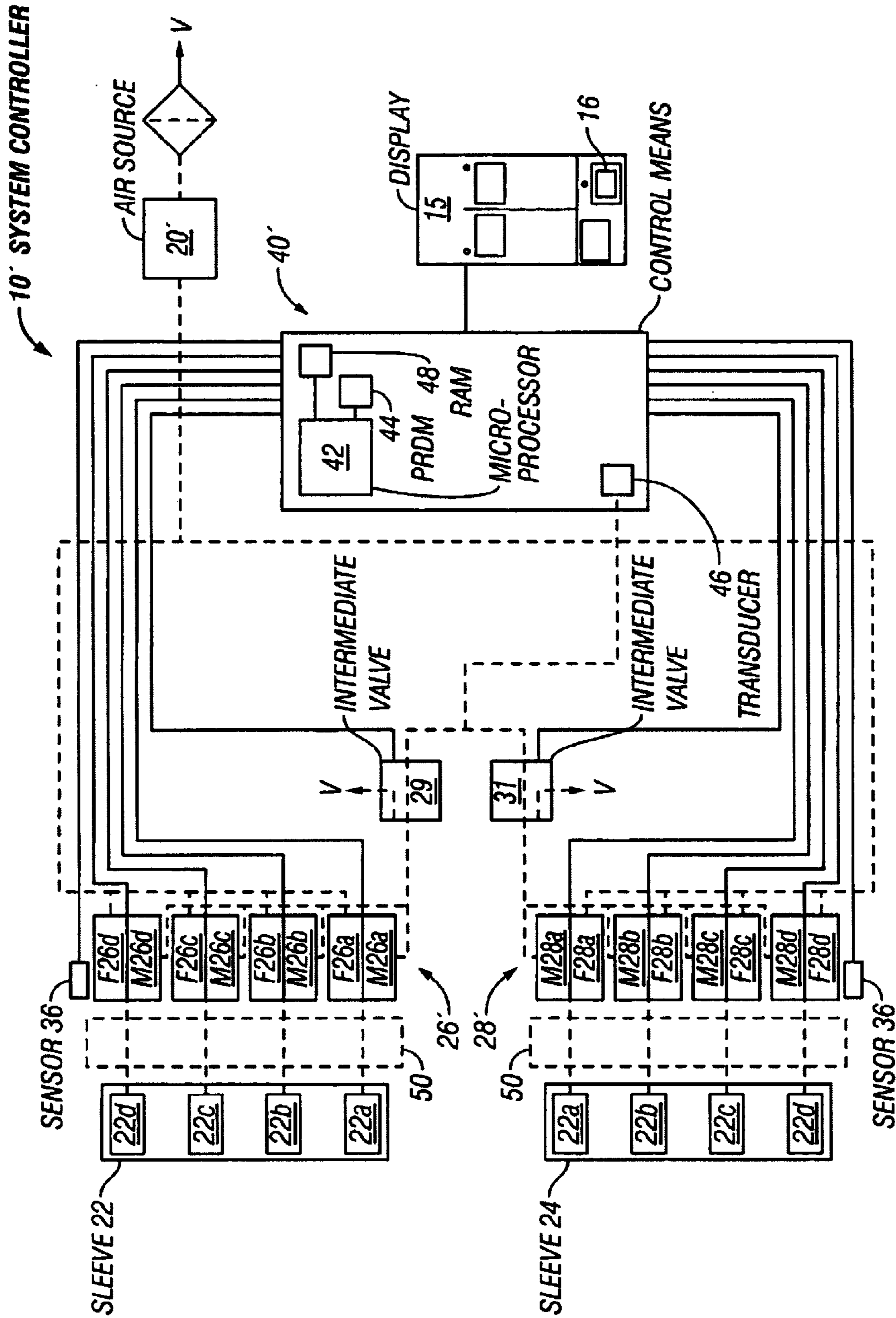

FIG. 7

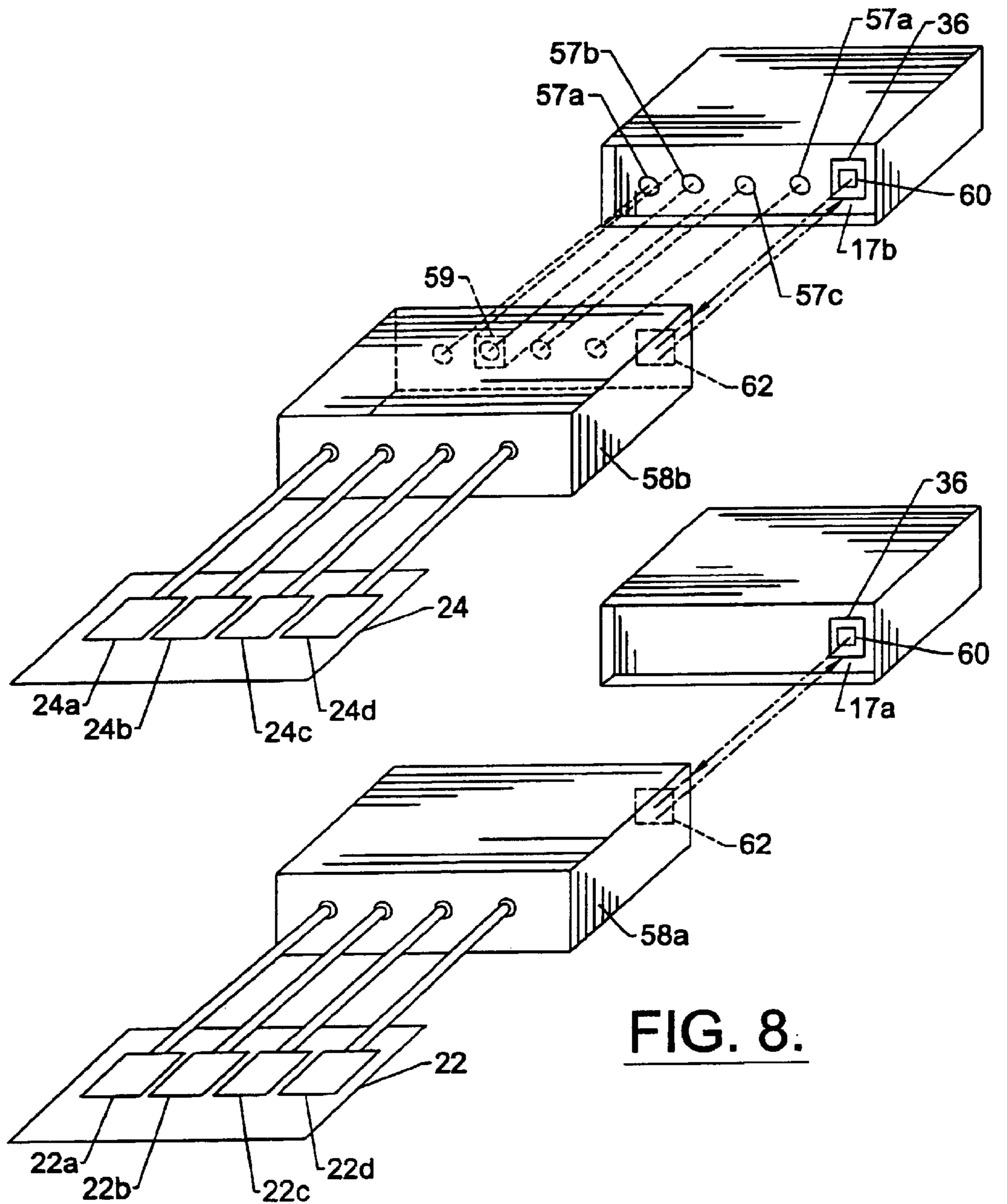

FIG. 8.

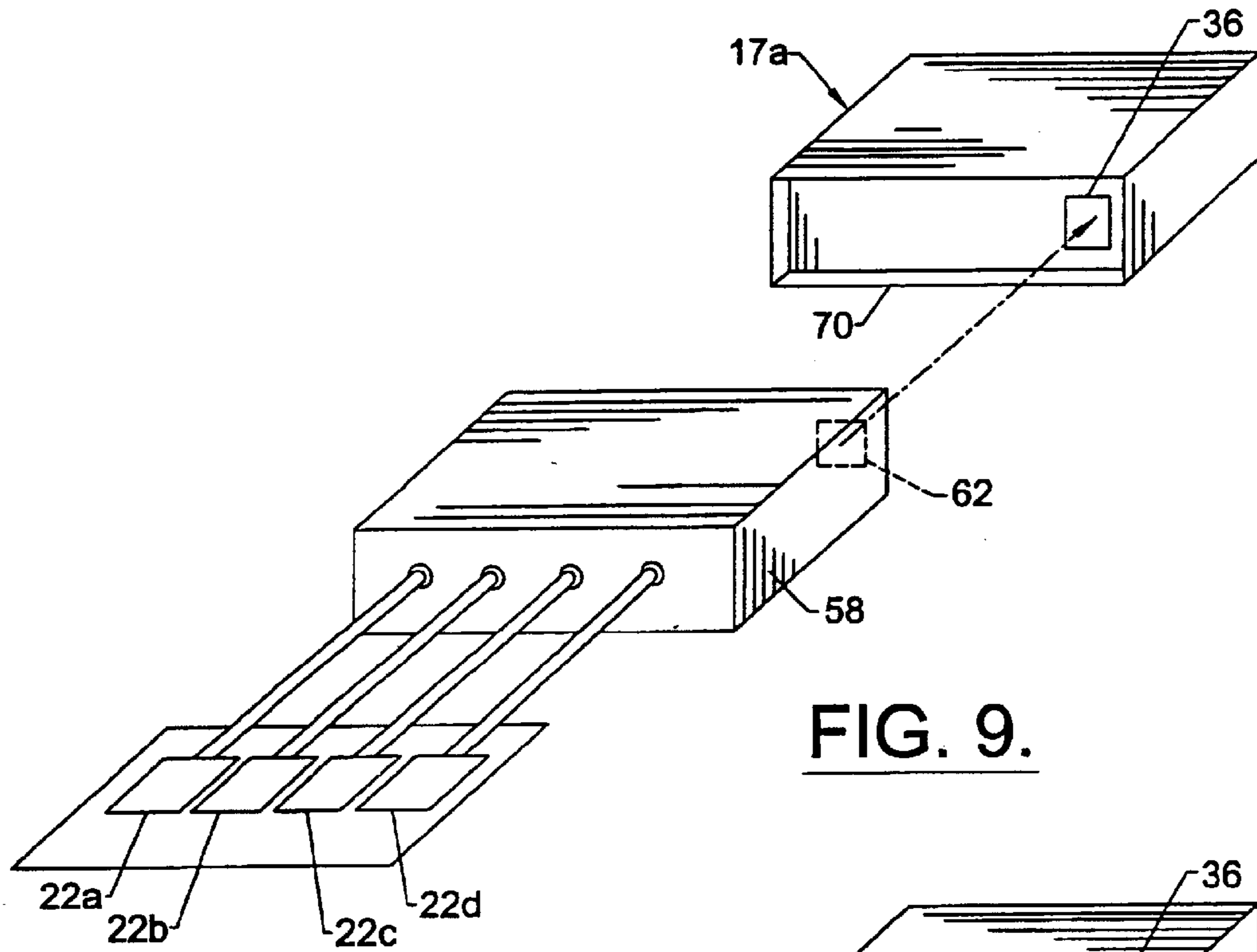

FIG. 9.

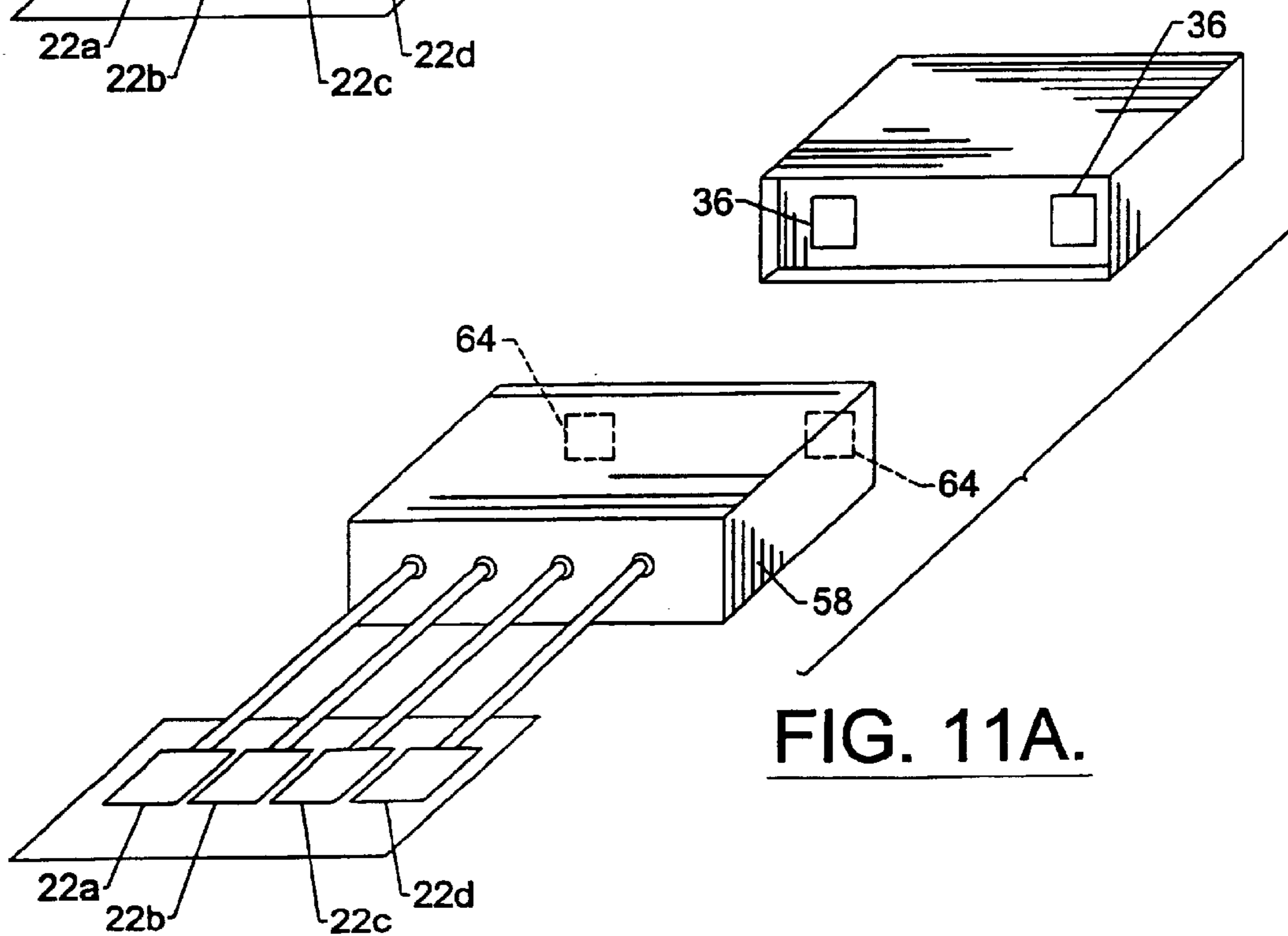

FIG. 11A.

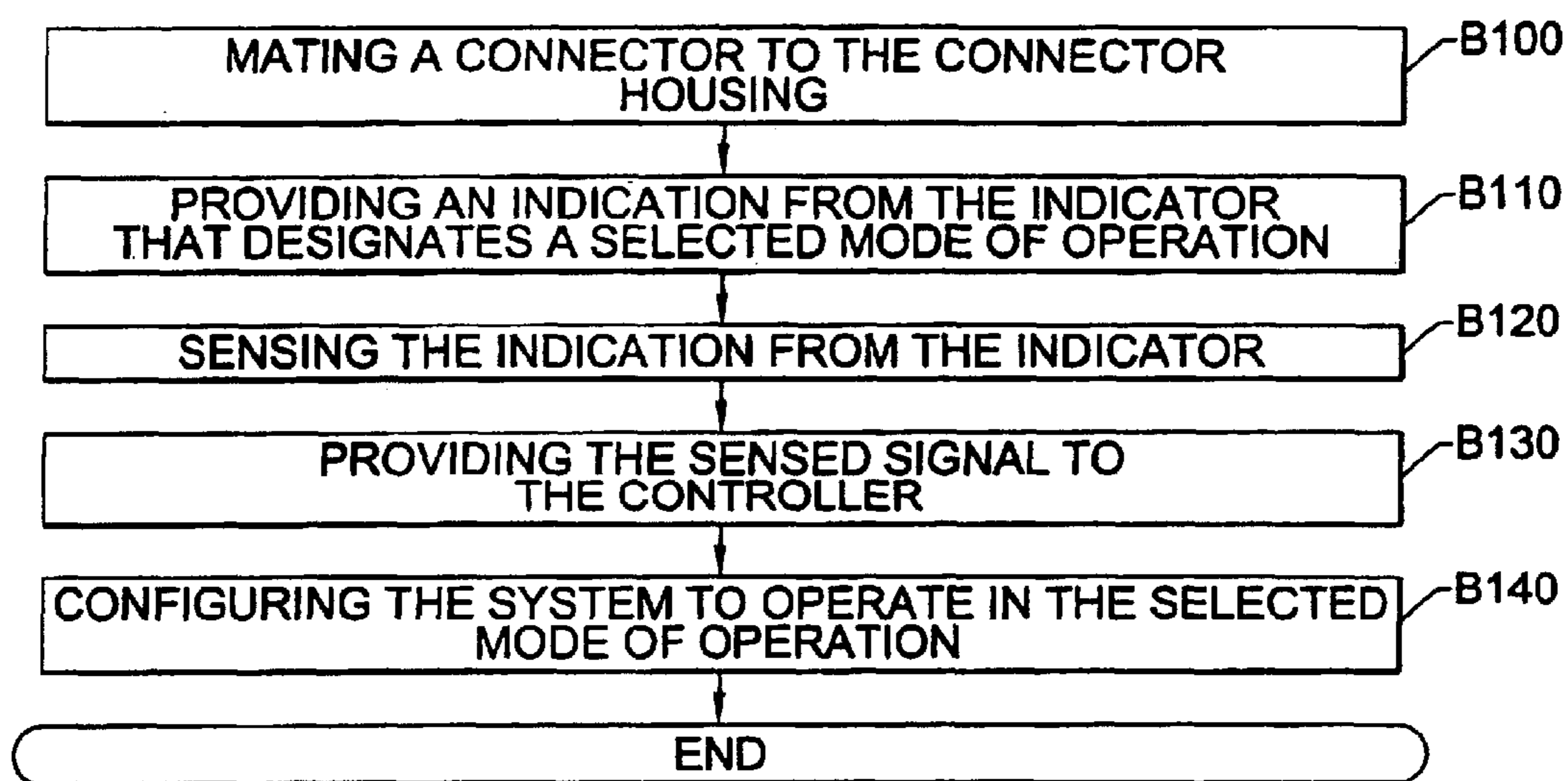

FIG. 10.

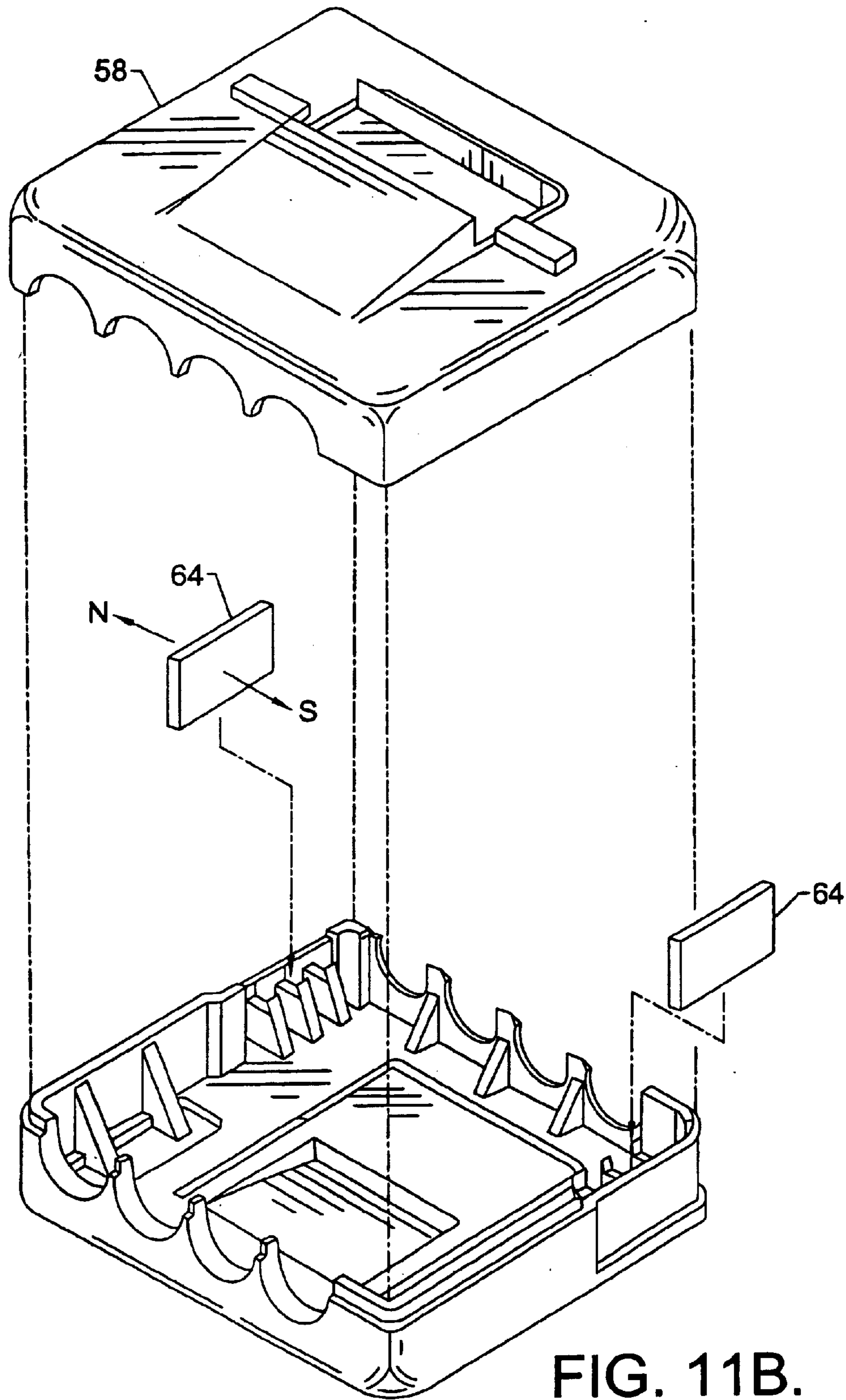

FIG. 11B.

UNIVERSAL CONNECTING DEVICE THAT DESIGNATES AN OPERATIONAL MODE

CROSS-REFERENCE TO RELATED APPLICATION

This application is a divisional from application 09/103,694 filed Jun. 24, 1998, now abandoned, which is a continuation-in-part of application Ser. No. 08/751,170, filed Nov. 15, 1996, now U.S. Pat. No. 5,951,502, which is a continuation-in-part to application Ser. No. 08/223,429, filed Apr. 5, 1994, now U.S. Pat. No. 5,575,762, which is hereby incorporated by reference.

FIELD OF THE INVENTION

The present invention relates to therapeutic medical devices and methods, and more particularly to devices and methods for improving venous blood flow in a patient.

BACKGROUND OF THE INVENTION

Deep vein thrombosis (DVT) and pulmonary embolism (PE) constitute major health problems in the United States. It has been estimated that 300,000 to 600,000 hospitalizations a year are attributable to DVT and PE conditions. Venous thromboembolism is also a significant risk in surgical patient populations where preoperative, operative and postoperative immobilization with concomitant loss of venous pump function causes blood stasis.

The use of prophylactic antithrombotic drugs for preventing DVT are known to the art. However, the efficacy of prophylactic administration of anticoagulants and antiplatelet agents has been disputed, and is certainly not absolute. An alternative approach, attractive because of its freedom from hemorrhagic side effects, is the use of physical techniques such as elastic stockings, passive leg exercise, electrical calf stimulation and external pneumatic compression of the legs. Pneumatic compression has been the most studied and appears to be an effective therapeutic technique. For example, the results of a comparison trial between sequential compression and uniform compression are disclosed in article by E. W. Salzman, et al., entitled *Effect of Optimization of Hemodynamics on Fibrinolytic Activity and Antithrombotic Efficacy of External Pneumatic Calf Compression*, *Annals of Surgery*, Vol. 206, No. 5, November (1987), pp. 636–641. Salzman et al. also discloses the lack of commercially available systems for applying external pneumatic compression in an optimized manner, based on blood flow velocity and volumetric flow rate, etc. Antithrombotic modalities based on sequential pneumatic compression are also disclosed in articles by J. A. Caprini, et al., entitled *Role of Compression Modalities in a Prophylactic Program for Deep Vein Thrombosis*, *Seminars in Thrombosis and Hemostasis*, Vol. 14, Supp., Thieme Medical Publishers, Inc., pp. 77–87, (1988); and Hull, et al., entitled *Effectiveness of Intermittent Pneumatic Leg Compression for Preventing Deep Vein Thrombosis After Total Hip Replacement*, *Journal of the American Medical Association*, Vol 263, No. 17, May, 2, 1990, pp. 2313–2317. Devices for performing sequential compression have also been patented. For example, U.S. Pat. No. 4,396,010 to Arkans, discloses a time-based sequential compression device for simultaneously inflating multiple limb sleeves. Time-based sequential compression devices are also publicly available from The Kendall Company, of Massachusetts. For example, FIG. 1 illustrates an experimentally derived graph of an inflation cycle for a Model 5325 sequential compression device, manufactured by The Kendall Company. It is believed,

however, that none of these sequential compression devices and methods provide for optimum blood flow, velocity and volumetric flow rate in recumbent patients.

Thus, notwithstanding these attempts to develop compression devices for preventing deep vein thrombosis and pulmonary embolism, there continues to be a need for a gradient sequential compression system which provides a high blood flow velocity and a highly therapeutic prophylactic modality to limbs of a recumbent user.

SUMMARY OF THE INVENTION

It is therefore an object of the present invention to provide a system and method for reducing the occurrence of deep vein thrombosis (DVT) and pulmonary embolism in recumbent users.

It is also an object of the present invention to provide a system and method for achieving a high venous blood flow rate in a limb of a user.

It is another object of the present invention to provide a system and method of sequentially establishing a gradient of compressive forces, which is pressure-based.

It is a further object of the present invention to provide a system and method of regulating a gradient of compressive forces, using real-time feedback.

It is still a further object of the present invention to provide a system and method of providing a prophylactic modality to limbs of a user in an alternating sequence.

It is another object of the present invention to provide a system and method for determining the selected mode of operation used for achieving a high venous blood flow rate in a body portion of a user based on the type of compression sleeve or the particular body portion to be treated.

It is still a further object of the present invention to provide a universal connecting device and method that identifies a mode of operation associated with a connector mated thereto and provides a signal indicative of the mode of operation to the system such that the system may be automatically configured to the selected mode of operation.

These and other objects, features and advantages of the present invention are provided by a compression system and method which provides cyclical squeezing and relaxing action to one or more limbs of a user. This occurs by sequentially establishing a decreasing gradient of compressive forces along the limbs in a proximal direction. In particular, the compression system includes one or more sleeves (e.g., calf, thigh, calf and thigh, arm, forearm, torso, etc.) which can be wrapped around and releasably secured to a limb(s) of a user. The sleeves have one or more inflatable chambers therein for retaining pressurized air upon inflation and for applying a compressive force to a limb. The compression system also includes a system controller for controlling transfers of pressurized air from an external or internal source to the inflatable chambers of the sleeves during respective inflation cycles, and for venting the pressurized air during respective deflation cycles. Transfers of air from the system controller to the sleeves are preferably provided by pneumatic connecting means which can include first and second conduit means. First and second conduit means preferably include a plurality of separate conduits or conduit ribbon.

According to one embodiment of the present invention, the system controller includes control means and first and second pluralities of feeder valves, responsive to control means, for enabling and disabling transfers of air from the source to respective ones of the inflatable chambers. Control

means is provided for controlling the sequence by which the feeder valves are directionally opened and closed so that during an inflation cycle a gradient of compressive forces can be sequentially established and maintained along a limb of a user for a predetermined time interval. In particular, according to a first embodiment, control means is provided for opening only one of the feeder valves to the source of pressurized air at a time, so that each of the inflatable chambers is independently inflated and regulated (e.g., measured and adjusted). Control means preferably includes a pressure transducer and means coupled thereto for sampling the pressures in each of the inflatable chambers and adjusting the pressures based on the samples so that the chambers are maintained at predetermined pressures, even if the limb sleeves are relatively loosely or tightly wrapped or the position of the limb is adjusted during treatment.

According to an aspect of the first embodiment of the present invention, the system controller includes first and second intermediate valves, connected between the source and the respective first and second pluralities of feeder valves. The intermediate valves, which are responsive to control means as well, enable transfer of air from the source to the first and second pluralities of feeder valves during respective first and second inflation cycles and vent air from the first and second pluralities of feeder valves during respective deflation cycles. In particular, the feeder valves and intermediate valves are directionally opened and closed to facilitate inflation, measurement and adjustment of the pressures in the limb sleeves.

The system controller also preferably includes means for sensing whether pneumatic connecting means is attached thereto. Sensing means may include an infrared, Hall effect or reflective sensor(s), for example. Control means also includes means, responsive to the sensing means, for automatically adjusting from a default two-limb mode of operation to a one-limb mode by preventing the occurrence of either the first or second inflation cycles if the respective first or second conduit means is disconnected from the system controller. The first and second inflation cycles are preferably 180° out of phase so that only one limb sleeve is being inflated at a time.

According to another aspect of the present invention, the sensor also determines the selected mode of operation to be used by the controller. As stated previously, the current invention utilizes different compression sleeves. These compression sleeves contain different numbers of inflation chambers and are formed differently to conform to and adequately compress selected portions of the body (i.e., calf, thigh, calf and thigh, arm, forearm, torso, ect.). Further, the system utilizes different pressure cycles for providing treatment to different body portions. The controller of the present invention determines the proper mode of operation for the system by using a sensor. This sensor senses an indication from an indicator connected to the compression sleeve being used by the system. This indicator designates the mode of operation associated with the sleeve. In this embodiment, the sensor provides a signal to the controller that identifies the selected mode of operation indicated by the sleeve. The controller configures the system in accordance with this signal to operate in the selected mode of operation. This, in turn, allows for the automatic configuration of the controller for a selected treatment without the need for user-input.

The system controller also includes means for detecting low and high pressure fault conditions which can be caused by disconnected or occluded conduits, and sleeves that are wrapped too loosely or too tightly about a limb.

According to yet another aspect of the invention, compressive forces are applied to a limb of a user by sequentially

compressing a distal portion and then a relatively proximal portion of the limb to provide respective first and second radially inwardly directed compressive forces thereto. The first compressive force is maintained above the second compressive force so that a decreasing pressure gradient is established in a proximal direction along the limb for a preselected time interval. The force is preferably maintained by measuring the compressive forces and adjusting (i.e., increasing or decreasing) the compressive forces to maintain predetermined forces.

More particularly, the invention includes a method of applying compressive forces to a limb of a user using a multi-chambered inflatable limb sleeve surrounding the limb. The method includes the steps of pressurizing a first chamber of the limb sleeve to a first predetermined chamber pressure and then pressurizing a second chamber, disposed proximally relative to the first chamber, to a second preselected chamber pressure, after the first chamber reaches a first threshold pressure. The first threshold pressure may be less than or equal to the first predetermined pressure.

Preferably, the second chamber pressurizing step occurs after a pressure in the first chamber has been established at the first predetermined pressure for at least a first time interval. A step is also performed to regulate the pressures in the first and second chambers at their respective predetermined pressures so that a constant pressure gradient is established therebetween. The regulating step may include the steps of measuring a pressure in the first chamber while preventing depressurization of the second chamber and vice versa. Additionally, the regulating step may include the steps of measuring a pressure in the first chamber after it has been inflated to the first threshold pressure and then re-measuring a pressure in the first chamber, after the second chamber has been inflated to the second threshold pressure.

The pressures in the chambers may also be adjusted by performing periodic reinflating steps (and also deflating steps). Similar steps may also be performed to inflate third and fourth, etc. chambers of the limb sleeve, in sequence, so that a monotonically decreasing pressure gradient is established and maintained in a proximal direction between the chambers of a sleeve(s).

A periodic adjusting step may also be performed to adjust the pressures in the chambers during an inflation cycle, by sampling (once or repeatedly) a pressure in a respective chamber to obtain a pressure sample and then adjusting the pressure by inflating or deflating the respective chamber, based on the value of the sample. Pressure samples from a respective chamber during an inflation cycle can also be averaged to determine whether a critical overpressure condition occurred during a prior inflation cycle and/or occurred multiple consecutive times during prior inflation cycles. If a critical overpressure condition has occurred, subsequent inflation cycles can be disabled to maintain the respective sleeve(s) in a continuously deflated state until the system is reset or the critical condition is corrected. Thus, instantaneous pressure spikes can be compensated to prevent the occurrence of shutdown when a single or relatively few aberrant pressure samples have been measured.

According to a second embodiment of the present invention, each of the feeder valves described with respect to the first embodiment are replaced by a pair of filling and monitoring valves. The filling valves are preferably normally-closed valves and the monitoring valves are preferably normally-open valves. Here, the filling valves have an open state for enabling one-at-a-time transfer of pressured air from a source to the inflatable chambers of the first and

5

second limb sleeves, in response to application of an energizing signal (e.g., logic 1), and a normally-closed blocking state which disconnects a respective chamber from the air source. In contrast, the monitoring valves have a normally-open state for enabling transfer of pressurized air from a respective inflatable chamber to an output thereof. These outputs are preferably pneumatically coupled through a corresponding three-way normally-open intermediate valve to a vent "V" or a pressure transducer in response to appropriate control signals. The monitoring valves also have a closed state (which can be achieved by application of an energizing signal (e.g., logic 1)) to prevent the escape of pressured air from a respective chamber when other chambers are being inflated or when the pressures in other chambers are being independently measured.

Control means, which is operatively connected to the filling, monitoring and intermediate valves, is provided for inflating a first inflatable chamber of the first limb sleeve by disposing the corresponding filling valve in an open state and the other filling valves in their respective normally-closed states. During inflation of the first inflatable chamber, the corresponding first monitoring valve is also disposed in a normally-open state so that the pressure in the first inflatable chamber can be measured in real time as it is being inflated and thereafter when the first inflatable chamber is fully inflated and the corresponding filling valve has been closed. Thus, in contrast to the first embodiment, the pressure in a chamber can be continuously measured as the chamber is being inflated to its respective predetermined pressure. This provides real-time feedback of the chamber pressure. Preferably, this real-time feedback is used by the control means to adjust the inflation time of the respective chamber during the current or subsequent inflation cycle(s). The amount of time needed to measure the pressure in a chamber after the respective filling valve closes can also be reduced because the pneumatic connecting lines between the respective monitoring valve and the pressure transducer will already be at least partially pressurized at the respective chamber pressure when the measurement operation commences.

BRIEF DESCRIPTION OF THE DRAWINGS

FIG. 1 is a graph illustrating an inflation cycle of a three chamber compression system, according to the prior art.

FIG. 2 is a perspective view of a system controller according to an embodiment of the present invention.

FIG. 3A is a graph illustrating first and second inflation cycles, according to the present invention.

FIG. 3B is a flow chart illustrating the operations performed by a system controller according to an embodiment of the present invention, during the first and second inflation cycles illustrated by FIG. 3A.

FIG. 4 is a schematic diagram illustrating a compression system according to a first embodiment of the present invention.

FIG. 5 is a perspective view of a valve manifold and associated hardware connected thereto.

FIG. 6A is a perspective view of a preferred pneumatic connecting means utilized by the present invention.

FIG. 6B is a cross-sectional view of the pneumatic connecting means according to FIG. 6A, taken along the lines 6B—6B'.

FIG. 7 is a schematic diagram illustrating a compression system according to a second embodiment of the present invention.

6

FIG. 8 is a perspective view of a universal connecting device according to one embodiment of the invention, wherein the device includes an optical signal generator.

FIG. 9 is a perspective view of a universal connecting device according to another embodiment of the invention.

FIG. 10 is a flow chart illustrating the operations performed by the universal connecting device according to an embodiment of the present invention.

FIG. 11A is perspective view of a universal connecting device including a Hall Effect sensor according to another embodiment of the invention.

FIG. 11B is an exploded perspective view of a connector for connecting to the universal connecting device according to another embodiment of the invention.

DESCRIPTION OF A PREFERRED EMBODIMENT

The present invention will now be described more fully hereinafter with reference to the accompanying drawings, in which preferred embodiments of a compression system and method are shown and described. This invention may, however, be embodied in different forms and should not be construed as limited to the embodiments set forth herein. Rather, these embodiments are provided so that this disclosure will be thorough and complete, and will fully convey the scope of the invention to those skilled in the art. Like numbers refer to like elements throughout.

Referring now to FIG. 2, a first embodiment of a system controller 10 according to the present invention will be described. The system controller 10 includes a housing formed by top and bottom housing portions 13 and 11, respectively. The top housing portion 13 may include an on/off switch 12 and a sloped display 15, such as an LED display or a more preferable liquid crystal display (LCD), for visually communicating chamber inflation information (e.g., pressure levels, chamber status), the mode of operation (e.g., one- or two-limb mode; and 2, 3 or 4-chamber mode, calf, thigh, calf and thigh, foot, arm, forearm, torso, ect.) and alarm, alert and fault conditions. The display may also provide means, responsive to actuation by a user or health care professional, for preselecting the desired pressure levels to be achieved during a sleeve inflation cycle. Based on experiment, it was determined by the inventors herein that pressures ranging from 65–15 mmHg are most preferred.

The system controller 10 may also include an internal source of pressurized air 20 such as a compressor, however, an external pneumatic fitting or similar device (not shown) may be provided adjacent the controller housing for connecting the controller 10 to an external source of pressurized air. A bracket 19 is also provided for securing an electrical cord (not shown) during periods of nonuse.

The system controller 10 also preferably includes a valve manifold 30 having a plurality of valves which facilitate inflation of limb sleeves 22 and 24. As illustrated by FIG. 4, the limb sleeves are preferably four-chamber sleeves. Alternatively, a plurality of single-chamber sleeves may be provided as an equivalent substitute for a multi-chamber sleeve. The valves in the manifold 30 are also directionally coupled and controlled to facilitate measurement and adjustment of pressures in the limb sleeves 22, 24, as explained more fully hereinbelow with respect to FIGS. 4 and 7. Preferred means 50 for pneumatically connecting the system controller 10 to the limb sleeves is also illustrated by FIGS. 6A–6B. Pneumatic connecting means 50 preferably comprises first and second conduit means 54, such as a plurality of flexible conduits or conduit ribbon 56, as illustrated in

FIG. 6B. These and other preferred features of the sleeves **22, 24** and connecting means **50** are disclosed in commonly assigned U.S. Pat. Des. 376,013, to Sandman et al. entitled Compression Sleeve for Deep Vein Thrombosis, and U.S. Pat. No. 5,588,954, to Ribando et al. entitled Connector for a Gradient Sequential Compression System, the disclosures of which are hereby incorporated herein by reference.

Referring now to FIGS. **3A–3B**, a preferred method of applying compressive forces to a limb of a user using a multi-chambered inflatable limb sleeve includes inflating (i.e., pressurizing) a first chamber of the limb sleeve to a first predetermined chamber pressure, shown as 50 mmHg, during a first inflation cycle (shown by solid lines). As will be understood by those skilled in the art, pressurization of a chamber causes a compression of the limb and provides a radially inwardly directed compressive force about the circumference of the limb. The predetermined chamber pressures may be user selected at the display, however respective default pressures are preferably fixed by the controller **10**. Thereafter, at time **B**, a second chamber of the sleeve, which is disposed proximally relative to the first chamber, is pressurized to a second predetermined pressure level, shown as 45 mmHg, by time **C**. Time **B** preferably occurs after the pressure in the first chamber reaches a threshold pressure, and more preferably after the first chamber pressure has been established at a respective predetermined pressure for a predetermined time interval. The threshold pressure may be less than or equal the first predetermined pressure of 50 mmHg.

As further illustrated, the time interval between times **B** and **A** is shown as 2.5 seconds, which is a default time interval. However, another predetermined time interval in the preferred range of 1–4 seconds may also be selected by a health care professional to achieve a preferred venous blood flow rate, based on the particular therapeutic application and medical needs of the recumbent user. According to an aspect of the present invention, means may be provided at the display **15** for allowing preselection of the desired time interval.

In the time interval between times **B** and **A**, a measurement (i.e., “sample”) of the pressure in the first chamber is taken at least once. Based on this sample, the pressure in the first chamber is adjusted to the 50 mmHg level, if necessary. Adjustment of the pressure in a chamber can occur by either inflating the chamber if the pressure sample is too low or deflating the chamber if the pressure sample is too high. As illustrated, the pressure in the first chamber is adjusted from below 50 mmHg to above 50 mmHg at least once prior to time **B**.

At time **D**, which preferably occurs 2.5 seconds after time **C**, the third chamber is inflated to a third predetermined pressure level, shown as 40 mmHg. This occurs at time **E**. In addition, during the time interval between times **D** and **C**, samples of the pressures in the first and second chambers are taken at least once and the pressures are independently adjusted to the 50 and 45 mmHg levels, if necessary. As explained more fully hereinbelow with respect to FIG. **4**, independent measurement of a pressure in a chamber occurs without depressurizing the other chambers. Furthermore, independent adjustment is achieved by pressurizing (or depressurizing) one chamber, while preventing pressurization (or depressurization) of the other chambers.

At time **F**, which preferably occurs 2.5 seconds after time **E**, the fourth chamber is inflated to a fourth predetermined pressure level, shown as 30 mmHg. This occurs at time **G**. The 50, 45, 40 and 30 mmHg levels establish a monotoni-

cally decreasing pressure gradient in a proximal direction along the limb of a user. It was determined by the inventors herein that a dual gradient of 5 mmHg between the first and second chambers and 10 mmHg between the third and fourth chambers is most preferred, however constant pressure levels in each chamber (i.e., no gradient) may also be possible if they are sequentially established.

In addition, during the time interval between times **F** and **E**, samples of the pressures in the first, second and third chambers are taken at least once and the pressures are independently adjusted to the 50, 45, and 40 mmHg levels, if necessary. And during the time interval between times **G** and **H**, samples of the pressures in each of the chambers are taken again and independent adjustments are made, if necessary. At time **H**, the chambers are simultaneously deflated. Time **H** preferably occurs 2.5 seconds after the pressure in the fourth chamber reaches a respective threshold pressure, and more preferably after the fourth chamber pressure has been established at 30 mmHg. Accordingly, times **B, D, F** and **H** preferably occur 2.5 seconds after times **A, C, E** and **G**, respectively. Alternatively, these time intervals may be preselected to be of varying length.

As illustrated, inflation of a first limb sleeve occurs 180° (e.g., 30 seconds) out of phase with respect to inflation of a second limb sleeve. In other words, only one sleeve is preferably inflated at a time (although both could be simultaneously inflated). Based on default settings which may be adjusted at the display **15**, the inflation cycle for the second sleeve (shown by dotted lines) begins 30 seconds after initiation of the first inflation cycle. Both the first and second inflation cycles preferably have default periods of 60 seconds, as illustrated. According to an aspect of the present invention, 30 seconds also sets the maximum inflation time. Thus, a sleeve will automatically be deflated if time **H** does not occur before 30 seconds have elapsed from the initiation of inflation. Alternatively, the second inflation cycle could begin automatically at time **H** (i.e., after all chambers in the first sleeve have been inflated for the requisite 2.5 seconds), rather than at the 30 second mark. In this latter case, the inflation cycle period for each sleeve would typically vary from cycle to cycle, as would be understood by those skilled in the art.

Referring now to FIG. **3B**, operations **70** performed by the system controller **10** during the first and second inflation cycles are summarized. In particular, the operations begin with the first sleeve and then an operation is performed to inflate the most distal chamber in the sleeve that is uninflated, Block **72**. Thereafter, an operation is performed to determine whether a respective predetermined pressure in the chamber has been reached, Block **73**. If not, pressurization is continued. However, if the respective predetermined pressure for the chamber has been reached, an interval timer is started, Block **74**. Thereafter, the most distal chamber of the sleeve is preferably selected, Block **75**, and then measured to obtain a pressure sample, while preventing depressurization of the other chambers, Block **76**. Based on the respective pressure sample, an operation is then performed to adjust (+/-) the chamber pressure, Block **77**. This is repeated for each of the next proximal chambers which have already been inflated, Blocks **78–79**. Alternatively, this order of sampling the pressures (i.e., distal→proximal) may be reversed. Once the time interval (e.g. 2.5 seconds) has elapsed, Block **80**, the timer is reset (Block **81**) and then a check is performed to see if all chambers have been inflated, Block **82**. If not, the next uninflated chamber is selected, Block **72**, and the operations are repeated. Alternatively, the time interval check performed at Block **80** may be per-

formed after each chamber has been checked instead of after all chambers have been checked. If the most proximal chamber has been inflated for the requisite elapsed time interval, then all chambers are deflated, Block 83. This begins the deflation cycle for the respective sleeve. The next sleeve is then selected, Block 84, and operations begin at Block 72, so that inflation of the next sleeve preferably occurs 180° out of phase with the previous sleeve (i.e., 30 seconds after commencement of inflation for the previous sleeve).

According to another aspect of the present invention, operations can also be performed in parallel with those operations illustrated by Block 72–83. In particular, a check is performed to determine if a prior inflation cycle has occurred, Block 71. If not, the normal operations (Blocks 72–82) are continued. If a prior inflation cycle has occurred, the pressure samples obtained from the prior cycle (or prior cycles) are averaged for each chamber, Block 84. Based on these averages, a check is performed to determine whether an excessive pressure condition has occurred, Block 85. If it has, subsequent inflation cycles are terminated until the system is reset, otherwise normal operations are continued. The system can be reset by accessing the display 15. According to this aspect of the present invention, instantaneous spikes in the pressures of one or more chambers can be compensated to prevent the occurrence of shutdown when a single or relatively few aberrant pressure samples have been measured during an inflation cycle or during consecutive inflation cycles (e.g., 5). As described below with respect to FIG. 4, these operations are preferably performed by a system controller 10 having a preferred microprocessor-based control means 40. Control means 40 may also perform the function of detecting an occluded conduit and causing the display 15 to indicate a high pressure alert condition. For example, if a chamber inflating operation causes an excessive pressure (e.g., 100 mmHg) to be measured, control means 40 can automatically cause shutdown and alert the user.

Referring now to FIG. 4, a compression system according to one embodiment of the present invention will be described. According to this embodiment, the compression system comprises a system controller 10. The controller 10 has means for controlling transfers of air from a source of pressurized air 20 (e.g., a compressor) to inflatable chambers of first and second limb sleeves 22, 24, respectively. As illustrated, each limb sleeve (or combinations of single- and dual-chamber sleeves) comprises a plurality of inflatable chambers 22a–d and 24a–d. For purposes of illustration only, dotted-lines have been used to show pneumatic connections and solid-lines have been used to show electrical connections.

The system controller 10 further comprises first and second pluralities of feeder valves 26, 28 for enabling and disabling transfers of air from the pressurized air source 20 to the inflatable chambers 22a–d and 24a–d. In particular, each of the first plurality of feeder valves 26a–d is connected to respective ones of the chambers 22a–d and each of the second plurality of feeder valves 28a–d is connected to respective ones of the chambers 24a–d. The feeder valves 26a–d and 28a–d are preferably Model 35 Series valves, which are publicly available from MAC Valves Inc. of Wixom, Mich.

Independent inflation control means 40 is also provided for opening the feeder valves 26a–d, 28a–d one-at-a-time during a respective first or second inflation cycle. Control means 40 is preferably microprocessor-based. For example, an application specific integrated circuit (ASIC) or a multi-

purpose microprocessor 42 may be provided to perform command and control operations, based on instructions contained in memory 44, such as programmable read-only memory (PROM). A multi-purpose microprocessor, such as a Motorola Semiconductor Corp., Model MC68HC11A1 microprocessor may be used. Control means 40 also preferably performs the function of regulating pressures in each of the inflatable chambers 22a–d and 24a–d.

Accordingly, regulation means is provided by the controller 10 for measuring the pressures in each of the chambers and for adjusting the pressures by intermittently inflating (and deflating) respective chambers to maintain pressure levels in the chambers at predetermined values, as illustrated by FIG. 3A. Means for performing chamber pressure measurements preferably comprises a pressure transducer 46. According to a preferred aspect of the present invention, only one pressure transducer for the entire system, as opposed to one transducer for each sleeve chamber, is required to independently measure the pressures in each of the chambers, without depressurizing any of the other chambers. The pressure transducer is preferably a Model MPX5050GP transducer, which is publicly available from Motorola Semiconductor Corp. of Phoenix, Ariz.

The system controller also preferably comprises intermediate valve means, shown as three-way intermediate valves 25 and 27. The intermediate valves are preferably Model 170 Series valves, which are also publicly available from MAC Valves Inc. In response to control signals provided by control means 40, the intermediate valves perform the function of enabling and disabling transfers of air from the source 20 to respective first and second pluralities of feeder valves 26 and 28 during the first and second inflation cycles. A pressure relief valve 34 is also provided in case pressures within the controller 10 exceed a safe level.

As stated previously, the controller of the present invention is configurable to operate in several modes of operation. For instance, the controller may be configured to treat deep vein thrombosis, as discussed in detail herein. Further, the controller may be configured to treat other ailments that respond positively to pneumatic compression, such as circulatory disorders, lymphatic disorders, organ failure, joint problems, soft tissue trauma, wound healing through management of localized congestion, counteracting shock by minimizing pooling of blood, physical massage, pneumatic tourniquets, etc. The modes of operation used for these treatments are based on several different factors. For instance, these different treatment plans may require a certain pattern for inflating the compression sleeves by the controller.

As an example, in some treatment therapies it is advantageous to only treat one limb of the patient (i.e., one leg). In this embodiment, only one compression sleeve will be connected to the compression system. This compression sleeve will be placed on the limb to be treated. With reference to FIG. 4, because only one compression sleeve is connected to the compression system, the controller 40 of this embodiment will control the feeder valves such that pressurized air is provided only to the connector connected to the compression sleeve and not to the other connector.

In another embodiment, however, it may be advantageous to only treat a portion of a limb, such as treating only the calf section of a leg or only the forearm section of an arm. In this embodiment, only certain ones of the feeder valves 26a–d and 28a–d will be connected to the compression sleeve. Thus, the controller 40 is configured to only supply pressurized air through the feeder valves that are connected to

the compression sleeve such that the inflation chambers that are mounted on the calf or forearm section of the limb are provided with pressurized air.

The controller of the present invention, also includes other modes of operation. As stated previously, the compression system of the present invention utilizes different types of compression sleeves that are configured to mount and conform to different body portions (i.e., calf, thigh, calf and thigh, foot, arm, forearm, torso, ect.). These differing compression sleeves require different compression cycles for proper treatment of the body portion to which they are mounted. Further, the compression system of the present invention also uses many different treatment methods for the same body portion based on the particular medical problems of the patient (i.e., deep vein thrombosis, circulatory disorders, lymphatic disorders, organ failure, joint problems, soft tissue trauma, wound healing through management of localized congestion, counteracting shock by minimizing pooling of blood, physical massage, pneumatic tourniquet ect). These differing treatment methods usually require different compression cycle patterns for inflating the compression sleeves. These differing compression cycles and the different treatment methods constitute different modes of operation for the controller.

In addition, at least one mode of operation includes an operation to verify and calibrate the system. In this mode of operation, a special compression sleeve or a calibration tube and connector, not shown, having only a single inflatable chamber or tube connected thereto is used to verify/calibrate the pressure transducer **46**. In this particular mode of operation, the appropriate feeder valves are opened by the controller to allow the pressure transducer **46** to be calibrated against a known pressure in the connected compression sleeve. The pressure of the transducer is displayed on the LCD display **15** and can be adjusted by the user to match the pressure in the sleeve or can be recalibrated by software in the microprocessor.

The different modes of operation of the present invention are typically stored in the controller memory **44** and are accessed by the microprocessor **42** to control the action of the feeder valves **26a-d** and **28a-d**. The modes of operation are defined by varying the number of chambers used, varying the amount of pressure in the sleeves, varying the pressurization times, and varying the sequence in which the compression sleeves are inflated. These modes of operation used by the microprocessor **42** may be either selected manually from the memory by the user through the display **15** or automatically by the use of a sensor **36**.

In the automatic or non-user input mode, a sensor **36** is used to select the proper mode of operation. For instance, in one embodiment, the sensor **36** is used to determine whether a compression sleeve **22** or **24** is connected to the controller **10**. The sensor **36** may also be used to determine whether more than one compression sleeve **22** or **24** is connected to the controller **40** for instances where two body portions (e.g., both legs) are to be treated. An example of these embodiments is shown in FIG. **8**, which illustrates a connecting devices **17a-b** and connectors **58a-b**. This system includes optical signal generators **60** that direct an optical signal to the indicators **62** of the connectors to the compression sleeves **22** and **24**. If the compression sleeves are connected to the connecting devices, the indicators **62** will reflect the optical signals and these reflected optical signals will be sensed by sensors **36**. As shown in FIG. **4**, the controller **40** receives the sensed signals from the sensors **36** and provides pressurized air to both of the compression sleeves **22** and **24** through the connecting devices **17a** and **17b**. However, if for

example compression sleeve **24** is not connected to the connecting device **17b**, the sensor will send a signal to the microprocessor that designates that the sleeve **24** is not connected to the connecting device **17b**. The microprocessor will then configure the controller to prevent the flow of pressurized air to that connecting device **17b**.

It is also advantageous in some embodiments to reconfigure the mode of operation for differing compression sleeves. As stated previously, the compression sleeves may differ in many ways based on the part of the body they are configured to conform to or the particular treatment to be performed on the body portion. For instance, in some embodiments the compression sleeves **22** and **24** may differ in the number of inflation chambers **22a-d** and **24a-d**. In this embodiment, the indicator **62** connected to the selected compression sleeve indicates either the number of inflation chambers or the pressure cycle to be used for the desired treatment. This indication is sensed by the sensor **36** and provided to the controller **40**. The controller **40** then automatically adjusts to one, two, three, four, ect. inflation chambers or adjusts the cycle of pressure to the inflation chambers. Thus, the system can be configured automatically to perform several modes of operation without user input.

The mode of configuration may also be indicated by configuring the output ports of the feeder valves. For example, a blocking device may be used to restrict the air flow from one or more of the output valves, where the blocked output ports designate a particular mode of operation (blocking two of the output ports to designate that only two chambers are to be inflated). The mode of operation is determined by the controller by initially assessing the pressure associated with each output port to determine whether the port is blocked. Based on this assessment of the output ports the controller determines the proper mode of operation.

In particular, with reference to FIG. **8** the output ports **17a-b** of FIG. **5** are illustrated in greater detail. In this embodiment, these output ports are configured to mate to a plurality of connectors **58a-b** that are associated with compression sleeves designated to operate with different modes of operation. These output ports contain output connectors **57a-d** that are connected to the feeder valves and are configured to mate to the connectors **58a-b**. In this embodiment, a blocking device **59** may be used to select the mode of operation of the controller. In particular, a blocking device **59** may be placed in front of one of the output ports (e.g., **57b**). As such, the blocking device **59** restricts the flow of air through the port **57b**. The blocking device **59** may be of any material sufficient to restrict the flow of air in the output port. For example, the blocking device could be a plug disposed in the connectors **58a-b** and cover the output ports when the output connectors **17a-b** are connected to the connectors. Further, the blocking device may be just a flat surface disposed in the connectors **58a-b** or even an adhesive tape covering the output port.

To ascertain the mode of the system, the controller initially determines the pressure on each port **57a-d**. In particular, when the system is activated, the controller initially applies air flow through each of the feeder valves **26a-d** to the output ports **57a-d**. The blocking device **59** will restrict the flow of air through the output port **57b**. The controller monitors the pressure associated with each output port **57a-d** through the transducer. The transducer will sense a minimal pressure on the output ports **57a**, **57c**, **57d** because they are not blocked by the blocking device **59**. However, the transducer will sense a relatively high pressure on the output port **57b** blocked by the blocking device **59** because

the blocking device **59** has restricted the flow of air through the output port. Essentially, the blocked output port represents a logic one because of the high pressure and the open output ports represent a logic 0 because of the minimal pressure.

Based on the information from sensing the pressure of each output port, the control device will access memory and determine the mode of operation associated with the configuration of the blocked output port **57b**. The controller then configures the system to operate in the selected mode.

As discussed above, the mode of operation may also be designated in this embodiment by blocking two or more of the output ports **57a-d** or by blocking a selected combination of the output ports **57a-d**.

In some embodiments of the present invention, the configuration of the system into the selected mode of operation is performed by use of a universal connecting device. FIG. **9** illustrates one of the output ports **17a** of FIG. **5** in greater detail. In this embodiment, these output ports are universal connecting devices configured to mate to a plurality of connectors that are associated with compression sleeves that are designated to operate with different modes of operation. In more detail, the universal connecting device contains a connector housing **70** for mating with a connector **58**. A sensor **36** is operably mounted to the connector housing **70** and an indicator **62** is connected to the connector. The indicator **62** designates the selected mode of operation associated with the connector.

FIG. **10** illustrates the operation of the universal connecting device. With reference to FIGS. **9** and **10**, in Block **100**, a connector **58** is mated to the connector housing **70**. An indication is then provided from the indicator connected to the connector, which designates a selected mode of operation associated with the connector. (Block **110**). This indication is sensed by the sensor **36**. (Block **120**). The sensor **36** provides the sensed signal to the microprocessor **42** of the controller **40**. (Block **130**). Finally, the controller configures the system to operate in the predetermined mode of operation designated by the indicator based upon the definition of the respective mode provided by the indicator. (Block **140**).

Although the universal connecting device is illustrated herein in connection with a device for improving venous blood flow, this is for illustrative purposes only. It is contemplated that the universal connecting device can be used for any type of system. Therefore, the universal connecting device should not be limited to the embodiments shown.

As shown above, the universal connecting device of the present invention can be used to determine the selected mode of operation associated with a connector connected thereto. The universal connecting device can have many different embodiments, three of which are shown below as examples.

In one embodiment of the universal connecting device, the sensor **36** comprises a Hall Effect sensor for sensing an indication from the indicator. As commonly known, a Hall Effect sensor detects the presence of magnetic signals and provides a signal based on these sensed magnetic signals. For example, the north and south poles of a magnet generate differing magnetic fields. A Hall Effect sensor provides different voltage signals based on whether it senses a positive magnetic signal (i.e., north pole of a magnet) or a negative magnetic signal (i.e., south pole of a magnet) or when no magnetic signal is present (i.e., no magnet at all). This aspect of the Hall Effect sensor can be utilized to detect different modes of operation associated with connectors connected to the universal connecting device. Hall Effect

sensors are publicly available from Micro Switch, a division of Honeywell, Inc.

FIG. **11A** illustrates an embodiment of the present invention including a Hall Effect sensor. In this embodiment, the indicator **62** is located in the connector **58** and comprises a plurality of magnets **64**. As shown in FIG. **11B**, these magnets are either configured in a particular arrangement or are placed in a designated position, wherein the arrangement or the position corresponds to a predetermined mode of operation associated with the connector. In other words, either the placement or the configuration (i.e., respective polarity) of the magnets in the connector or a combination of both placement and configuration corresponds to a particular mode of operation for the system. Further, the absence of a magnet may also correspond to a particular mode. The placement and configuration of the magnets also correspond to a particular data point stored in the memory **42** of the controller, shown in FIG. **4**.

In operation, the Hall Effect sensor **36** senses the placement or configuration of the magnets and provides a signal to the controller **40** that represents the mode of operation associated with the connector. The microprocessor **42** compares this sensed signal with the data stored in memory **44** and selects the data point that corresponds to the sensed signal. This data point is then used by the microprocessor **42** to configure the controller **40** for operating in the selected mode of operation. Thus, the controller **40** will properly control the action of the feeder valves **26a-d** and **28a-d** to provide pressurized air to the inflatable chambers of the compression sleeve and will also control the feeder valves to provide the correct cycle of pressurized air to the inflatable chambers depending on the designated treatment.

As stated above, the Hall Effect sensor **36** senses the configuration and placement of the magnets in the connector. For instance, in one embodiment a single magnet may be placed at different locations in the connector wherein each location signifies different modes of operation. In this embodiment, a Hall Effect sensor is placed at each possible location that the magnet may be placed. The Hall Effect sensor that corresponds to the placement of the magnet will provide a signal to the microprocessor. The microprocessor then compares the sensed signal to the data stored in memory **44** and configures the system to operate in the selected mode of operation.

FIG. **11B** illustrates another embodiment of the universal connector with a Hall Effect sensor. In this embodiment, a plurality of magnets **64** are configured such that their configuration designates a mode of operation associated with the connector **58**. The configuration of the magnets relates not only to their position in the connector **58** but also to their presence (i.e., is there a magnetic signal present) and polarity (i.e., north or south pole). For instance, as illustrated in FIG. **11B**, the magnets **64** are arranged by polarity in the connector. The polarity of these magnets **64** are sensed by the Hall Effect sensors **36**, and these sensed signals are provided to the microprocessor **44** of the controller **40** which compares the sensed signals to the data in memory **42**. Table 1, shown below, illustrates the different combinations of two magnets used as indicators in a connector.

TABLE 1

Mode of Operation	Configuration	
	Magnet 1	Magnet 2
1	No Magnet	No Magnet
2	No Magnet	North
3	No Magnet	South
4	North	No Magnet
5	South	No Magnet
6	North	North
7	North	South
8	South	North
9	South	South

As seen from Table 1, two magnets can be used to designate nine different modes of operation based on the presence and or configuration of the poles of the magnets. These modes of operation can be stored in memory and retrieved based on the configuration of the magnets

As stated previously, some embodiments of the universal connecting device utilize an optical signal sensor to detect the mode of operation associated with a connector mated to the connecting device. With reference to FIG. 9 two of these embodiments are illustrated. In the first embodiment, the universal connecting device of the present invention further comprises an optical signal generator **60** and the indicator **62** connected to the connector **58** includes either a reflective or nonreflective material. The optical signal generator **60** directs an optical signal toward the indicator **62** of the connector **58** and the indicator **62** will reflect the signal if a reflective material is used or will not reflect the signal if a nonreflective material is used. Whether the indicator **62** reflects or does not reflect the optical signal indicates different modes of operation for the system. In this embodiment, the sensor **36** comprises an optical sensor that senses the optical signal reflected by the indicator **62** and provides a signal to the microprocessor **42** of the controller **40** designating whether a reflected signal was detected or not. Based on whether a signal was detected or not the microprocessor **42** determines the mode of operation associated with the connector **58** and configures the system.

As discussed in relation to the Hall Effect sensor, the indicator **62** of this embodiment may comprise a plurality of reflective and nonreflective strips that can be configured to provide different combinations for designating particular modes of operation much like the magnets shown in Table 1.

In another embodiment of the present invention, the indicator **62** comprises a material having a specified level of reflectivity that corresponds to an associated mode of operation. For instance, in this embodiment, the optical signal generator **60** directs an optical signal to the indicator **62** attached to the connector. The indicator **62** partially reflects the optical signal with a level of reflectivity that is associated with the selected mode of operation of the connector. This partially reflected signal is detected by the sensor **36**, and the sensor provides the detected signal to the microprocessor of the controller **60**. Here again, the microprocessor **42** compares the detected signal to data in the memory **44** and based on this comparison configures the controller **40** to operate in the mode of operation designated by the indicator **62**.

Alternatively, instead of using the sensor **36** to determine the mode of operation, the system controller **10** may include means, responsive to actuation from the display **15**, for manually configuring the controller **10** in the proper mode of operation. For example, a controller **10** having a 2-sleeve/4-chamber default configuration, as illustrated and described

herein, can be readily converted to a 3-chamber or 2-chamber system by selecting the desired mode at the display **15**. In addition, the controller **10** may also include means, preferably responsive to actuation from the display, for configuring the controller **10** in a customized mode of operation which allows sleeves of different length to be used. Thus, a first sleeve having four chambers may be used on one limb and a second sleeve having two or three chambers may be used on another limb. Further, the display may be used to select differing modes of operation for specific treatments. As will be understood by those skilled in the art, these customized modes of operation may be controlled by the microprocessor **42**. Selecting means, such as a membrane switch **16**, may be provided at the display **15** for selecting these modes of operation.

Referring again to FIGS. 3A and 4, the operations performed by the system controller **10** of FIG. 4 during the first and second inflation cycles will be described. It should be noted that this description of operations is provided as an illustrative example and should not otherwise be construed as limiting the scope of the invention. The operations begin with the steps of connecting each of the chambers of the first and second limb sleeves **22** and **24** to respective conduits of first and second conduit ribbons **56**, and then inserting respective male connecting members **52**, at the source ends of the conduits, into each of the output ports **17a** and **17b**. Thereafter the controller is turned on by accessing the on/off switch **12**. This causes the controller **10** and particularly control means **40** to perform various diagnostic start-up operations, such as performing a check, which is responsive to sensing means **36**, to determine whether one or more of the sleeves is disconnected.

Control means **40** controls operations for inflating the first chamber **22a** to 50 mmHg by providing a first control signal (e.g., logic 0) to feeder valves **26a** and **28a-d** and to the second intermediate valve **27**. Second control signals (e.g., logic 1) are also provided to feeder valves **26b-d**, along the solid control lines, as shown. Second control signals are also provided to the first intermediate valve **25** and to a source valve **32**, which is connected to the source of pressurized air **20**. These valves are preferably three-way, normally-open, solenoid controlled valves, as illustrated. Accordingly, the application of a second or "energizing" control signal to the solenoid of each valve causes the output of the valve to be directionally coupled to a first input, shown as opposite the input side of the valve. However, the application of a first or "deenergizing" signal to the solenoid of each valve causes the output to be directionally coupled to a second input (or vent), shown as orthogonal to the output side of the valve.

These initial operations will cause the source of pressurized air **20** to be pneumatically connected to the first chamber **22a** and inflation will begin. Chambers **22b-d** and chambers **24a-d** are disconnected from the source and are not inflated at this time. In particular, feeder valves **26b-d** will be held in an energized but blocking state, as shown by the pneumatic termination (---|), and feeder valves **28a-d** and the second intermediate valve **27** will be held in a deenergized and open state. As shown, the feeder valves **26a-d** and **28a-d** have been modified so that the first input is plugged. In addition, an energizing signal is also generated to open the source valve **32** and the first intermediate valve **25**. A deenergizing signal is also generated to open the feeder valve **26a**, which is now in a normally-open position and can accept pressurized air from the source **20**.

Because the volume of the first chamber **22a** will typically vary depending on the size of the sleeve and limb (and also whether the sleeve is loosely or tightly wrapped around the

limb) control means **40** also performs special startup control operations, which typically occur during the first 5–10 inflation cycles for a respective sleeve. Here, during the initial inflation cycle for each sleeve, the controller inflates each chamber for a respective predetermined default time interval (retained in PROM **44**) and then takes a measurement to determine whether the default time interval was long enough (or too long) to achieve the desired pressure level. If the measurement is too low, control means **40** will automatically increase the time interval so that during the next inflation cycle, the updated inflation time interval will be longer to correspond to the actual time needed for this chamber to inflate properly. These operations, which provide real-time feedback, typically occur repeatedly for each chamber during the first 5–10 inflation cycles or until the system “levels-out” at the desired inflation times. Because the respective inflation times are stored in volatile memory **48**, such as RAM, these operations will need to be repeated every time the system is turned-on or reset. The PROM **44** may also contain a maximum fill time interval, so that if a chamber is not properly inflated in that interval, control means **40** will generate a fail-to-fill alert. This condition typically occurs when one of the conduits is disconnected from a chamber.

These special control operations will also need to be performed if the user-selected pressure levels, described above with reference to FIG. 2, are greater than or less than the default pressure levels of 50, 45, 40 and 30 mmHg. Moreover, if during the course of operation, the user or health care professional actuates the display **15** and adjusts the default pressure levels to new values, these special start-up control operations will be automatically performed again to generate new inflation times and adjust the system to the new pressure levels.

If the default time intervals for inflating each of the respective chambers is assumed accurate for purposes of illustration, then chamber **22a** will inflate to the first predetermined pressure at time A, as shown. At time A, the deenergizing signal is applied to the source valve **32** to cause it to switch to its normally open position. When this occurs, the source will vent air through the controller housing to the surrounding atmosphere. The application of the deenergizing signal to the source valve also closes off the system so that the pressure transducer can accurately sample the pressure in the first chamber **22a**.

Control means **40** also regulates the pressure in the first chamber **22a** by adjusting it to the first predetermined pressure if the sample is outside an acceptable pressure tolerance. For example, a short inflating or deflating step can be performed to adjust the pressure in the first chamber **22a**. In order to deflate the first chamber **22a**, the second or energizing control signal can be temporarily removed from the first intermediate valve **25** in order to vent some of the air from the chamber through the feeder valve **26A** and first intermediate valve **25**. Alternatively, the energizing signal can also be temporarily reapplied to the source valve to obtain another “burst” of air into the first chamber **22A**. To hold the first chamber **22a** at 50 mmHg, an energizing signal is applied to feeder valve **26a** to cause it to enter a blocking state, as shown by the pneumatic termination (----).

After the predetermined time interval of 2.5 second has elapsed from time A, control means **40** begins operations at time B for inflating the second chamber **22b** by applying an energizing signal to the source valve **32** and first intermediate valve **25** and applying a deenergizing signal to feeder valve **26b**, while holding feeder valves **26a** and **26c–d** in an energized (i.e., blocking) state.

At time C, the second chamber **22b** will be inflated to 45 mmHg and then control means **40** will deenergize the source valve **32** and energize feeder valve **26b** to thereby cause the source to vent to atmosphere while feeder valve **26b** blocks the escape of air from the second chamber **22b**. Measurement of the pressures in the first and second chamber can then be independently performed by first applying a temporary deenergizing signal to feeder valve **26a** to open it and then taking a pressure sample, followed by adjustment, if necessary. Next, a temporary deenergizing signal is applied to feeder valve **26b**, so that the pressure transducer **46** can sample the pressure in the second chamber **22b** as well. Then while feeder valve **26b** is still open, control means **40** can again perform the necessary operations to separately adjust the pressures in the second chamber **22b**. The above-described operations are again repeated at times D–G, so that at time H, control means **40** can provide a deenergizing signal to the first intermediate valve **25** and to each of the feeder valves **26a–d** so that all chambers vent through the first intermediate valve **25**.

Analogous operations are also performed by control means **40** to inflate and regulate the second sleeve **24**. In particular, deenergizing signals are maintained at each of the feeder valves **26a–d** and first intermediate valve **25** so that the first sleeve **22** remains in a deflated state. To begin inflation of the first chamber **24a**, control means **40** provides energizing signals to open the source valve **32** and the second intermediate valve **27** and also provides energizing signals to feeder valves **28b–d** to maintain them in the blocking state. Accordingly, a connection is provided between the source **20** and first chamber **24a** at the beginning of the second inflation cycle.

As described above, means, such as a membrane switch at the display **15** or an RS232 data port, may also be provided to allow adjustment of the controller **10** so that a 2, 3, . . . , N-chamber mode of operation may be readily achieved in either sleeve. For example, controller **10** having a 2-sleeve/4-chamber default configuration as described herein, can be converted to a 3-chamber system by selecting this mode at the display **15**. Based on this selection, control means **40** would disable normal operations for inflating fourth chambers **22d**, **24d** by continuously providing energizing signals to feeder valves **26d** or **28d** to maintain them in a blocking state. Similarly, four chamber operation in the first sleeve and two chamber operation in the second sleeve can be selected. In this mode, control means **40** would disable normal operations for inflating third and fourth chambers **24c–d**, by continuously providing energizing signals to feeder valves **28c–d** to continuously maintain them in a blocking state during the second inflation cycle.

Referring now to FIG. 5, the valve manifold **30** is illustrated in greater detail. In particular, the first and second output ports **17a–b** and associated conduits **17c–d** are provided for pneumatically connecting each of the outputs of the feeder valves **26a–d** and **28a–d** to respective ones of the conduits **54**. In addition, energizing and deenergizing control signals from control means **40** to feeder valves **26a–d** and **28a–d** and first and second intermediate valves **25**, **27** are provided by electrical connections **29**, as shown.

Referring now to FIG. 7, a compression system according to a second embodiment of the present invention will be described. This embodiment is functionally similar to the first embodiment, but has notable difference as described more fully hereinbelow. According to this embodiment, the compression system comprises a system controller **10'** for controlling transfers of pressurized air from an internal or external source **20'** to a plurality of inflatable chambers

22a-d and 24a-d during respective inflation cycles and for venting the source 20' at vent "V" during respective deflation cycles and typically also when the pressure in any chamber is being measured after the respective chamber has been inflated to a predetermined level. For purposes of illustration only, dotted-lines have been used to show pneumatic connections and solid-lines have been used to show electrical connections. The system controller 10' further comprises first and second pluralities of feeder valve means 26', 28' for enabling and disabling transfers of air from the pressurized air source 20' to the inflatable chambers 22a-d and 24a-d. Each of the four feeder valve means in the first and second pluralities 26' and 28' preferably comprises a pair of filling and monitoring valves: (F26a, M26a), (F26b, M26b), (F26c, M26c), (F26d, M26d) and (F28a, M28a), (F28b, M28b), (F28c, M28c), (F28d, M28d). The use of a pair of filling and monitoring valves provides a number of preferred advantages relative to the normally-open feeder valves 26a-d and 28a-d of FIG. 4, as described more fully hereinbelow.

The filling valves F26a-d and F28a-d are preferably normally closed valves and the monitoring valves M26a-d and M28a-d are preferably normally open valves. These valves, which may be combined as a valve manifold, are available from Matrix S.r.l, Ivrea, Italy. Here, the filling valves F26a-d and F28a-d have an open state for enabling one-at-a-time transfer of pressurized air from the source 20' to the inflatable chambers 22a-d and 24a-d of the first and second limb sleeves 22 and 24, in response to application of an energizing signal (e.g., logic 1), and a normally-closed blocking state which disconnects a respective chamber from the air source 20'. In contrast, the monitoring valves M26a-d and M28a-d have a normally-open state for enabling transfer of pressurized air from a respective inflatable chamber (attached to an input thereof) to an output thereof. These outputs can be pneumatically coupled, through a corresponding three-way normally-open intermediate valve (29 or 31), to the vent "V" or a pressure transducer 46 in response to appropriate control signals. As illustrated, the intermediate valves 29 and 31 have two outputs. In the first normally-open state, the input to each intermediate valve 29 and 31 is pneumatically connected to a first output thereof (which is connected to the vent "V") and in the second open state the input to each intermediate valve is pneumatically connected to the pressure transducer 46. Each intermediate valve can be disposed in the second open state by applying an energizing signal thereto. The monitoring valves M26a-d and M28a-d also have a closed state (which can be achieved

by application of an energizing signal (e.g., logic 1)) to prevent the escape of pressured air from a respective chamber when other chambers are being inflated or when the pressures in other chambers are being independently measured.

Control means 40', which is operatively connected to the filling, monitoring and intermediate valves, is also provided for inflating a first inflatable chamber 22a of the first limb sleeve 22 by disposing the corresponding filling valve (e.g., F26a) in an open state and the other filling valves F26b-d and F28a-d in their respective normally-closed states. During inflation of the first inflatable chamber 22a, the corresponding first monitoring valve (e.g., M26a) is also disposed in a normally-open state so that the pressure in the first inflatable chamber 22a can be monitored (i.e., measured or sampled) in real time as it is being inflated and thereafter when the first inflatable chamber 22a is fully inflated and the corresponding filling valve (e.g., F26a) has been closed. Monitoring of the pressure in the first inflatable chamber 22a is preferably achieved by also disposing the corresponding three-way intermediate valve (e.g., 29) in its second open state (in response to an energizing logic 1 signal) so that the pressure transducer 46 embodied in the control means 40' becomes pneumatically coupled to the first inflatable chamber 22a and performs a measurement of the pressure therein. Thus, in contrast to the first embodiment of FIG. 4, the pressure in a chamber can be continuously measured as the chamber is being inflated to its respective predetermined pressure. This provides real-time feedback of the chamber pressure. Preferably, this real-time feedback is used by the control means 40' to adjust the inflation time of the respective chamber during the current or subsequent inflation cycle(s). The amount of time needed to measure the pressure in a chamber after the respective filling valve closes can also be reduced since the pneumatic connecting lines between the respective monitoring valve and the pressure transducer 46 will already be at least partially pressurized at the respective chamber pressure.

As illustrated by Tables 2 and 3, the above described operations for inflating and measuring pressure in the first inflatable chamber 22a of the first limb sleeve 22 are repeatedly performed by the control means 40' during the inflation of the remaining chambers of the limb sleeves 22 and 24. In these tables, the label "C" indicates that the respective valve is in a "closed" state, the label "O" indicates that a respective valve is in an "open" state and the label "V" indicates that a respective valve is in a "venting" state.

TABLE 2

CHAMBER	VALVE											
	F26a	M26a	F26b	M26b	F26c	M26c	F26d	M26d	29	31	F28 a-d	M28 a-d
FILL 22a	O	O	C	C	C	C	C	C	O	V	C	O
MONITOR 22a	C	O	C	C	C	C	C	C	O	V	C	O
FILL 22b	C	C	O	O	C	C	C	C	O	V	C	O
MONITOR 22b	C	C	C	O	C	C	C	C	O	V	C	O
FILL 22c	C	C	C	C	O	O	C	C	O	V	C	O
MONITOR 22c	C	C	C	C	C	O	C	C	O	V	C	O
FILL 22d	C	C	C	C	C	C	O	O	O	V	C	O
MONITOR 22d	C	C	C	C	C	C	C	O	O	V	C	O

TABLE 3

CHAMBER	VALVE								29	31	F26 a-d	M26 a-d
	F28a	M28a	F28b	M28b	F28c	M28c	F28d	M28d				
FILL 24a	O	O	C	C	C	C	C	C	V	O	C	O
MONITOR 24a	C	O	C	C	C	C	C	C	V	O	C	O
FILL 24b	C	C	O	O	C	C	C	C	V	O	C	O
MONITOR 24b	C	C	C	O	C	C	C	C	V	O	C	O
FILL 24c	C	C	C	C	O	O	C	C	V	O	C	O
MONITOR 24c	C	C	C	C	C	O	C	C	V	O	C	O
FILL 24d	C	C	C	C	C	C	O	O	V	O	C	O
MONITOR 24d	C	C	C	C	C	C	C	O	V	O	C	O

15

The drawings and specification disclose typical preferred embodiments of the present invention and, although specific terms are employed, they are used in a generic and descriptive sense only and not for purposes of limitation, the scope of the invention being set forth in the following claims.

That which is claimed is:

1. A universal connecting device comprises:

a connector housing adapted for mating with a connector having a designated mode of operation associated with the connector; and

a sensor, operably mounted to said connector housing, for identifying the mode of operation associated with a connector mated to said connector housing, wherein said sensor provides a signal indicative of said mode of operation.

2. A universal connecting device according to claim 1, wherein said device further comprises an indicator operably attached to said connector for designating a predetermined mode of operation associated with said connector.

3. A universal connecting device according to claim 2, wherein said sensor is a Hall Effect sensor.

4. A universal connecting device according to claim 3, wherein said indicator comprises at least one magnet configured to designate the mode of operation associated with said connector, and wherein said sensor provides a signal indicative of the mode of operation designated by said indicator.

5. A universal connecting device according to claim 2 wherein said device further comprises an optical signal generator for generating an optical signal, wherein said indicator defines a level of reflectivity that corresponds to a predetermined mode of operation, and wherein said indicator partially reflects the optical signal generated by said optical signal generator to indicate the predetermined mode of operation associated with said connector.

6. A universal connecting device according to claim 2 further comprising at least one pressure device for generating a pressure, wherein said indicator defines a blocking device that blocks the release of pressure from said pressure device to indicate a first mode of operation, and wherein the sensor identifies the mode indicated by said indicator by sensing the pressure blocked by said indicator.

7. A method of selecting an operation mode from a plurality of operation modes of a processing device based on identifying a characteristic of a connector connected thereto, wherein said method includes the steps of:

mating said connector to said processing device;

providing an indication from said connector, wherein said indication designates a predetermined mode of operation;

sensing said indication from said connector; and

configuring said process device to operate in the predetermined mode of operation designed by said connector.

8. A method according to claim 7 wherein said providing step provides a magnetic signal designating a predetermined mode of operation and wherein said sensing step comprises the step of sensing the magnetic signal provided in said providing step.

9. A method according to claim 7 wherein said method further comprises the step of directing an optical signal to an indicator attached to said connector, wherein said providing step comprises the step of partially reflecting said optical signal, wherein said reflected signal represents a predetermined mode of operation for said process device, and wherein said sensing step comprises the step of sensing a reflected optical signal from said indicator.

10. A method according to claim 7, wherein said method further comprises the step of generating a pressure for applying to said connector, wherein said providing step comprises blocking the pressure, thereby indicating a first mode of operation, and wherein said sensing step comprises sensing the pressure blocked in said providing step to thereby determine the mode of operation indicated in said providing step.

11. A connecting device to connect a control device to a peripheral device, the connecting device comprising:

an interface connector for the control device;

a complementary connector for a peripheral device adapted for mating with the interface connector;

wherein the complementary connector designates a predetermined mode of operation to operate the peripheral device; and

a sensor associated with the interface connector operable to identify and provide a signal indicative of the predetermined mode of operation designated by the complementary connector;

wherein the sensor enables configuration of the control device to operate the peripheral device according to the predetermined mode of operation designated by the connector.

12. A connecting device according to claim 11, further comprising an indicator operably attached to the complementary connector, wherein the indicator designates the predetermined mode of operation to operate the peripheral device.

13. A connecting device according to claim 12, wherein said sensor is a Hall Effect sensor.

16

23

14. A connecting device according to claim 13, wherein said indicator comprises at least one magnet configured to designate the mode of operation associated with said complementary connector, and wherein said sensor provides a signal indicative of the mode of operation designated by said indicator. 5

15. A connecting device according to claim 12, further comprising an optical signal generator for generating an optical signal, wherein said indicator defines a level of reflectivity that corresponds to the predetermined mode of operation, and wherein said indicator partially reflects the optical signal generated by said optical signal generator to 10

24

indicate the predetermined mode of operation associated with said connector.

16. A connecting device according to claim 12 further comprising at least one pressure device for generating a pressure, wherein said indicator defines a blocking device that blocks the release of pressure from said pressure device to indicate a first mode of operation, and wherein the sensor identifies the mode indicated by said indicator by sensing the pressure blocked by said indicator.

* * * * *

UNITED STATES PATENT AND TRADEMARK OFFICE
CERTIFICATE OF CORRECTION

PATENT NO. : 6,988,423 B2
APPLICATION NO. : 09/755313
DATED : January 24, 2006
INVENTOR(S) : Bolam et al.

Page 1 of 1

It is certified that error appears in the above-identified patent and that said Letters Patent is hereby corrected as shown below:

On the first page of the Letters Patent, in the "Related U.S. Application Data" section (60), the text which now reads,

"09/103,694, filed Jun. 29, 1998, now abandoned"

should appear as follows:

--09/103,694, filed on Jun. 24, 1998, now Pat. No. 6,786,879--

Signed and Sealed this

Seventeenth Day of June, 2008

A handwritten signature in black ink that reads "Jon W. Dudas". The signature is written in a cursive style with a large, stylized initial "J".

JON W. DUDAS
Director of the United States Patent and Trademark Office