



US006983774B2

(12) **United States Patent**  
**Hsu**

(10) **Patent No.:** **US 6,983,774 B2**  
(45) **Date of Patent:** **Jan. 10, 2006**

(54) **TIRE REINFORCING ARRANGEMENT**

(56) **References Cited**

(76) Inventor: **Shut Chen Hsu**, No. 7, Alley 1, Lane  
163, Sec. 3, Nung-Chuan Rd., I Lan  
City (TW)

**U.S. PATENT DOCUMENTS**

5,988,244 A \* 11/1999 Chang ..... 152/158  
6,637,486 B1 \* 10/2003 Rolla ..... 152/381.6  
6,705,368 B2 \* 3/2004 Glinz et al. .... 152/400  
2004/0016490 A1 \* 1/2004 Shimura et al. .... 152/156

(\*) Notice: Subject to any disclaimer, the term of this  
patent is extended or adjusted under 35  
U.S.C. 154(b) by 49 days.

\* cited by examiner

*Primary Examiner*—Frantz F. Jules

(74) *Attorney, Agent, or Firm*—Rosenberg, Klein & Lee

(21) Appl. No.: **10/679,306**

(22) Filed: **Oct. 7, 2003**

(57) **ABSTRACT**

(65) **Prior Publication Data**

US 2005/0039833 A1 Feb. 24, 2005

A tire reinforcing arrangement includes an outer tire having  
two hooked flanges at two sides, two annular spare tires  
bilaterally set inside the outer tire, each annular spare tire  
being formed of a plurality of spare tire blocks that are  
fastened to one another by links and screw bolts, each spare  
tire block having two mounting through holes, a top locating  
groove adapted to receive the hooked flanges of the outer  
tire, an embossed bottom wall, and two projecting portions  
diagonally disposed at two ends, and stretchers respectively  
stopped between the annular spare tires.

(30) **Foreign Application Priority Data**

Aug. 20, 2003 (TW) ..... 92122934 A

(51) **Int. Cl.**

*B60C 17/04* (2006.01)

(52) **U.S. Cl.** ..... 152/156; 152/520; 152/248

(58) **Field of Classification Search** ..... 152/158,  
152/152, 159, 165, 169, 520, 391, 400, 248  
See application file for complete search history.

**1 Claim, 8 Drawing Sheets**

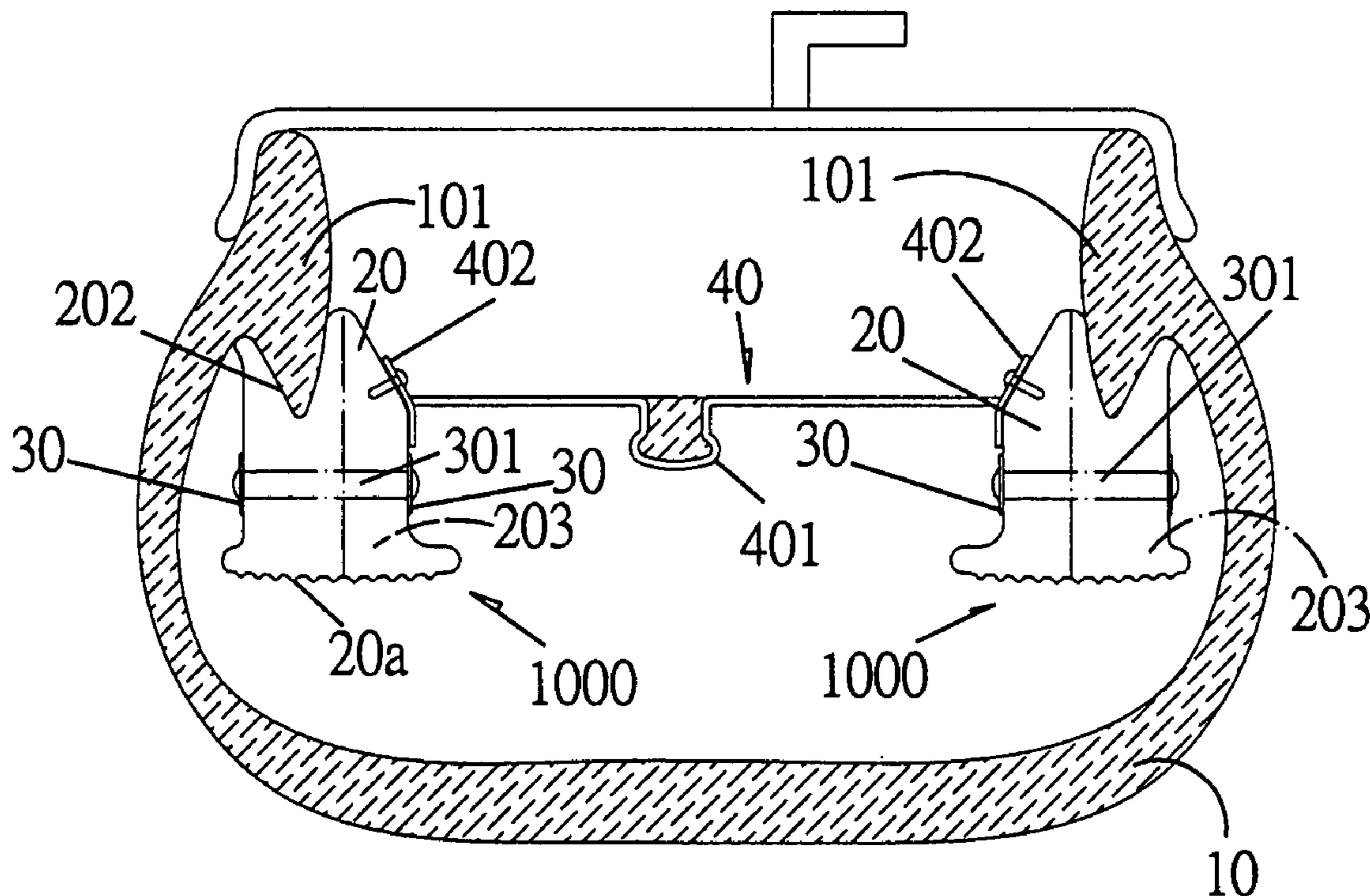

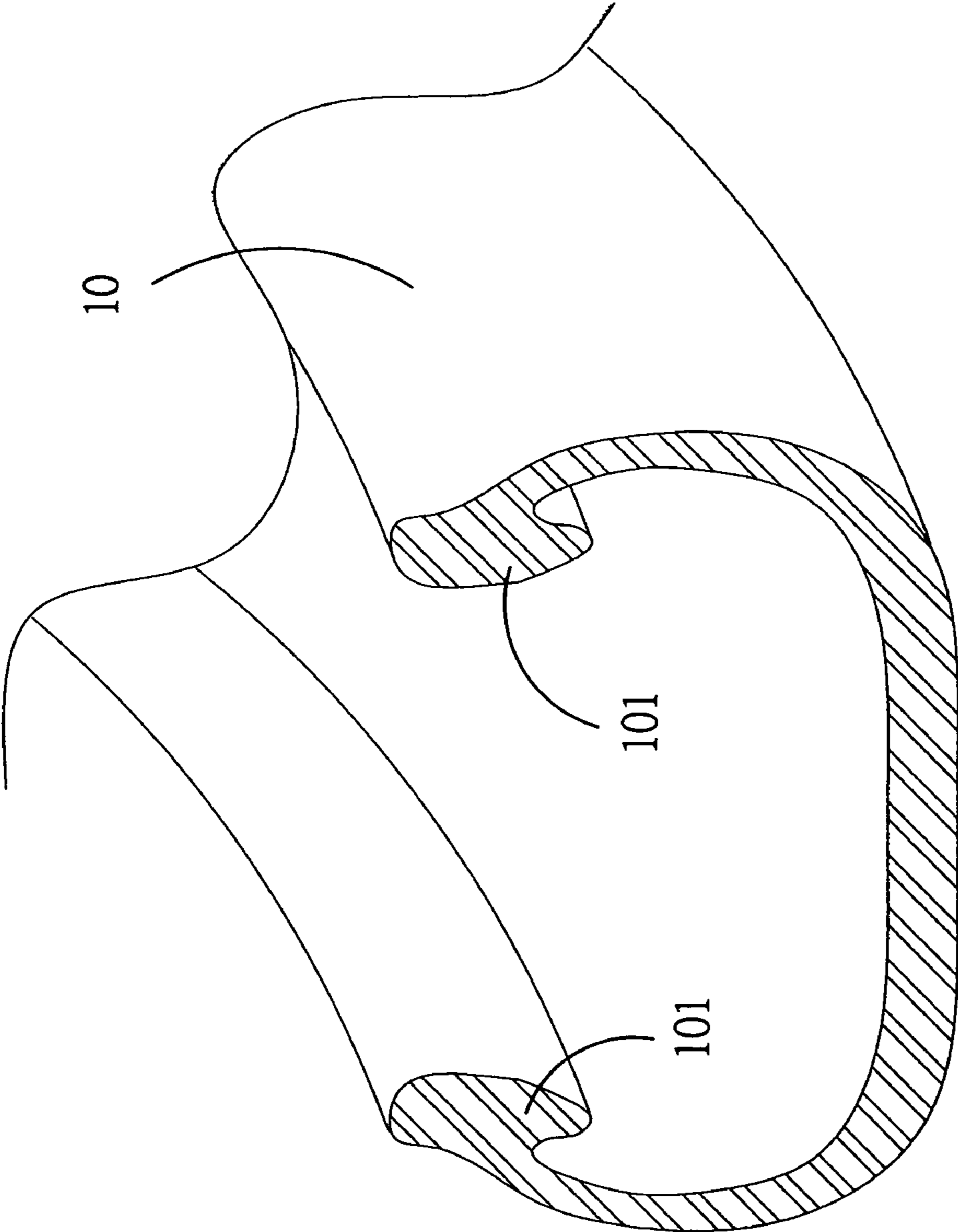

FIG. 1

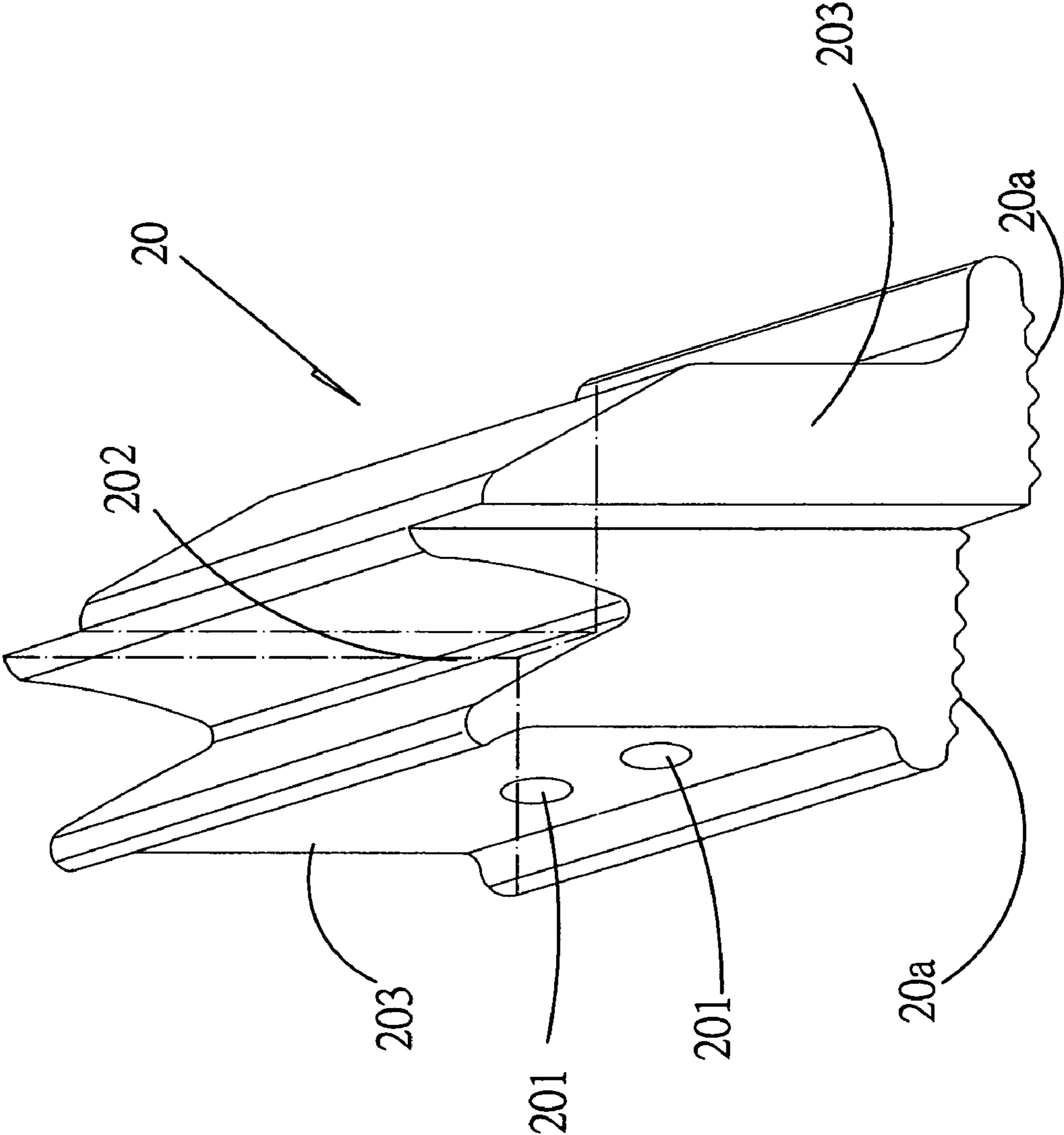

FIG. 2

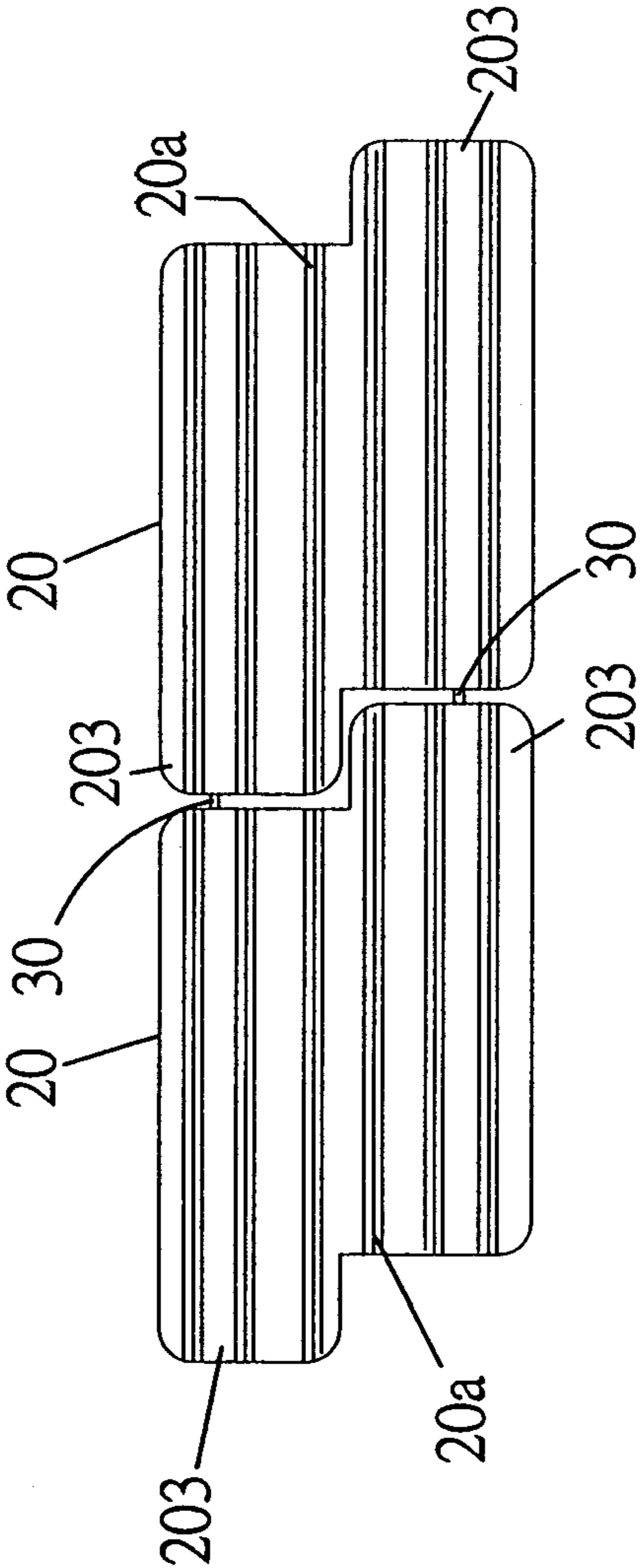

FIG. 3

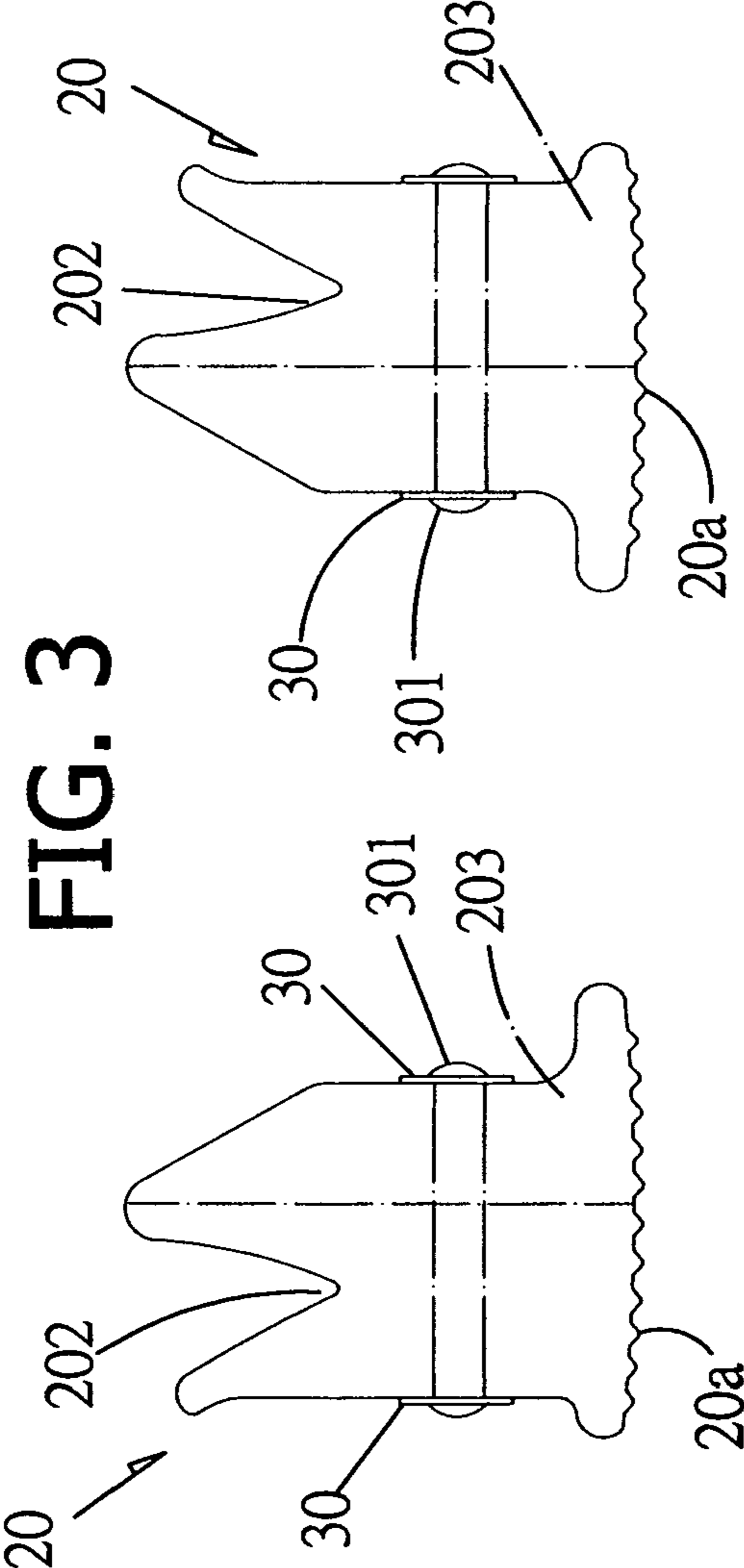

FIG. 5

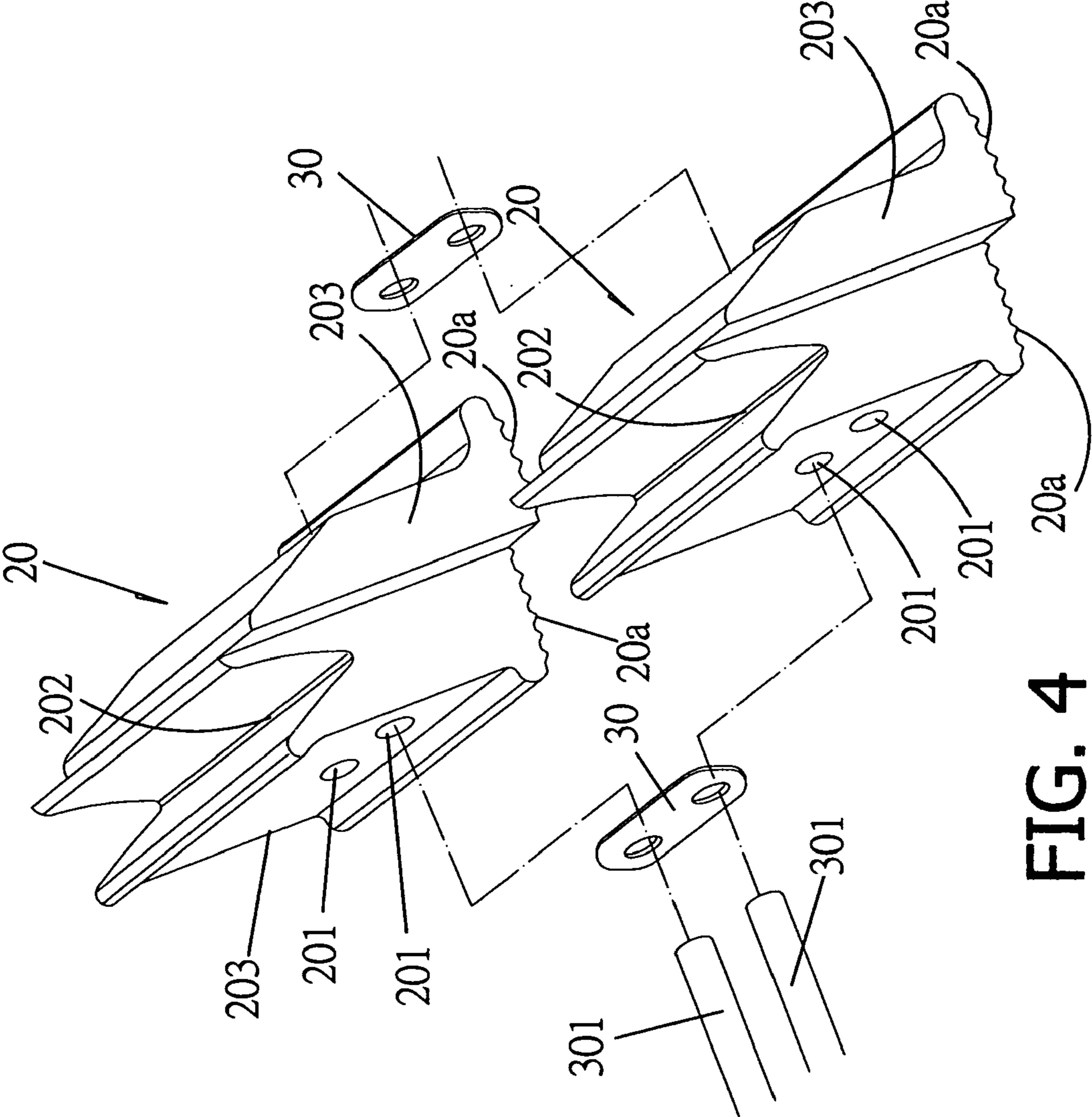

FIG. 4

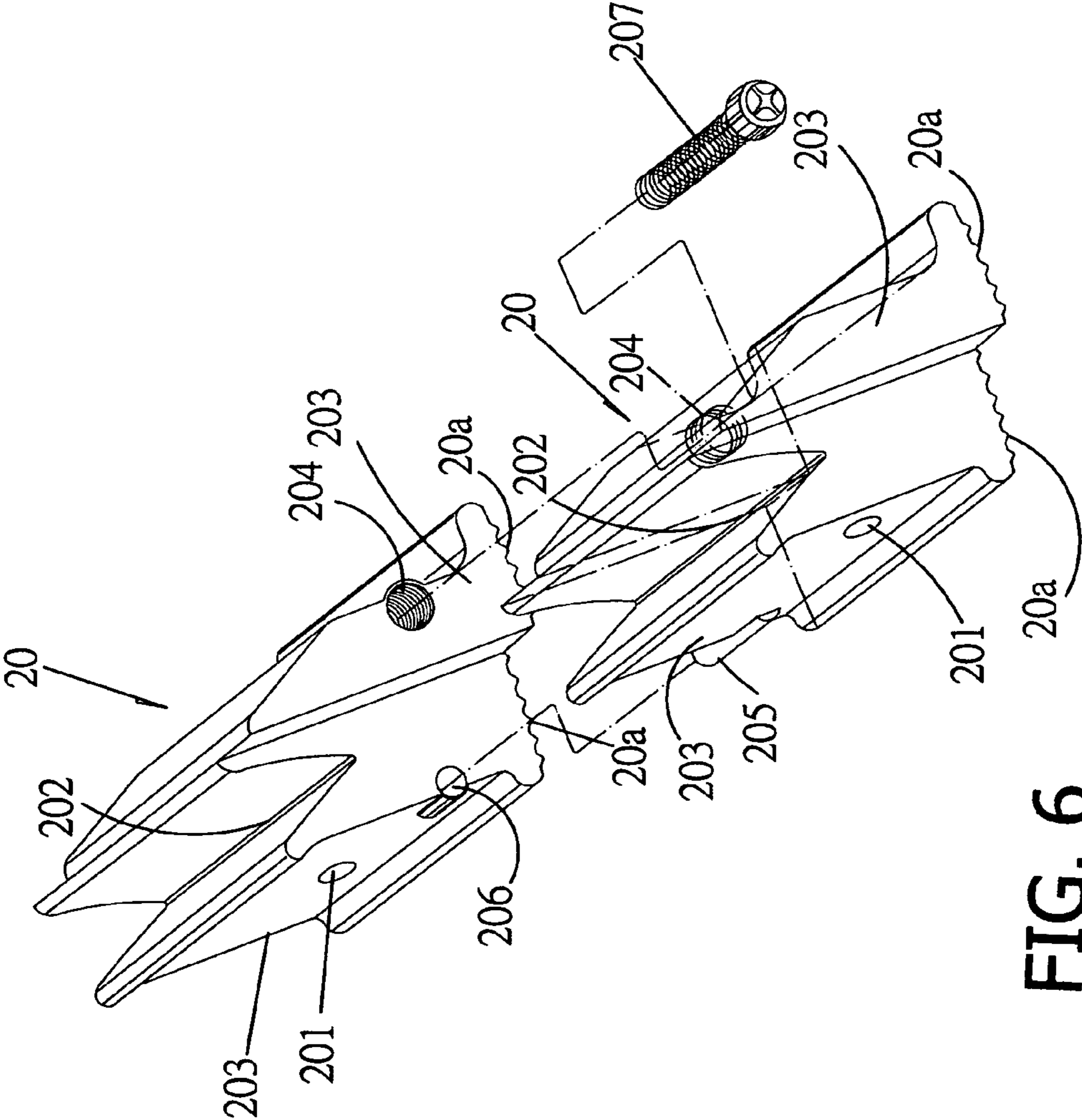

FIG. 6

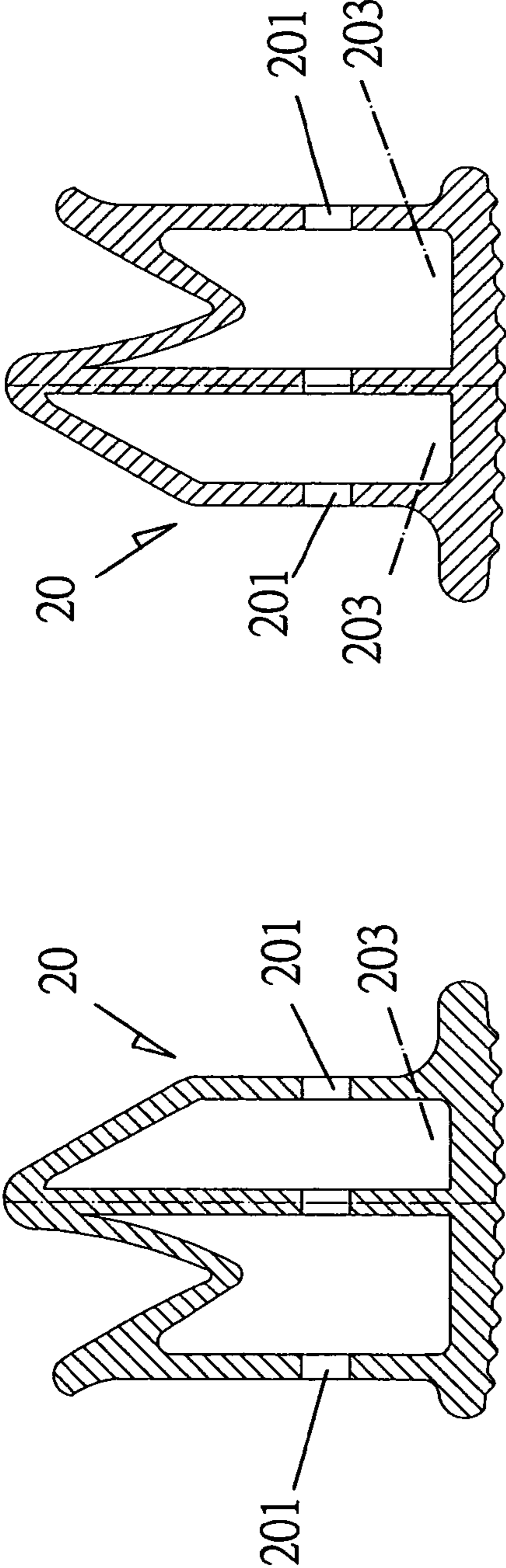

FIG. 7

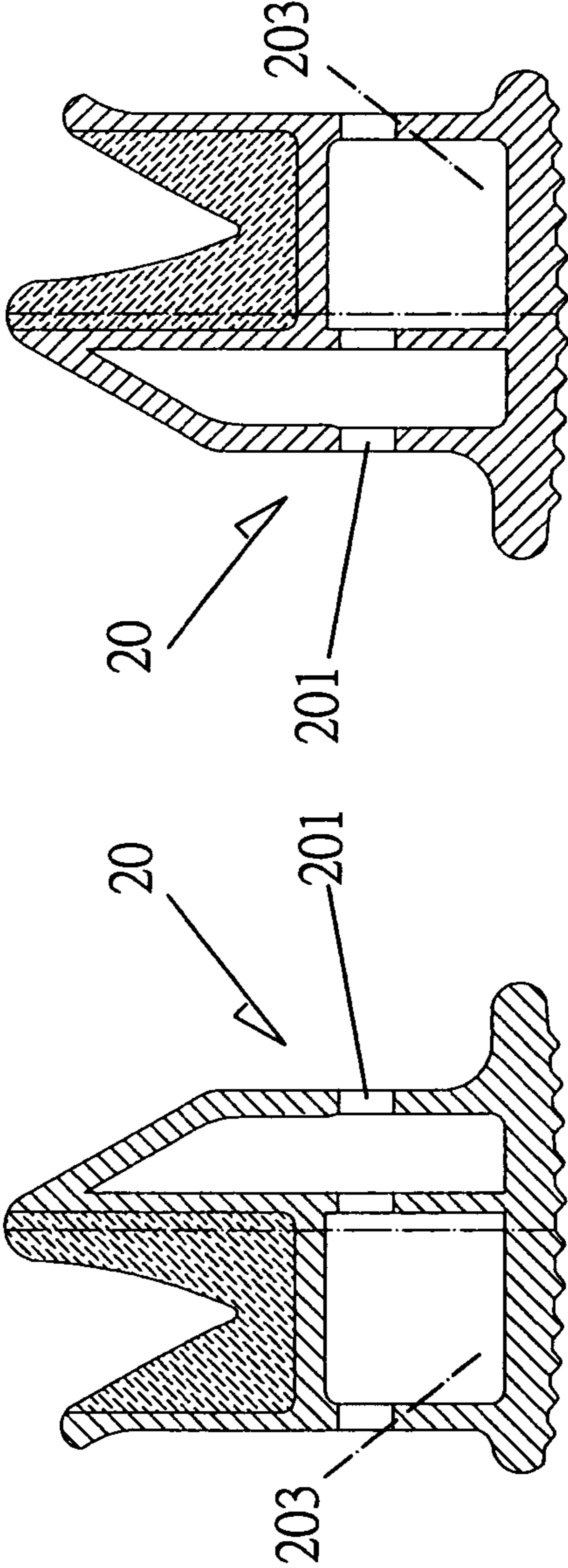

FIG. 8

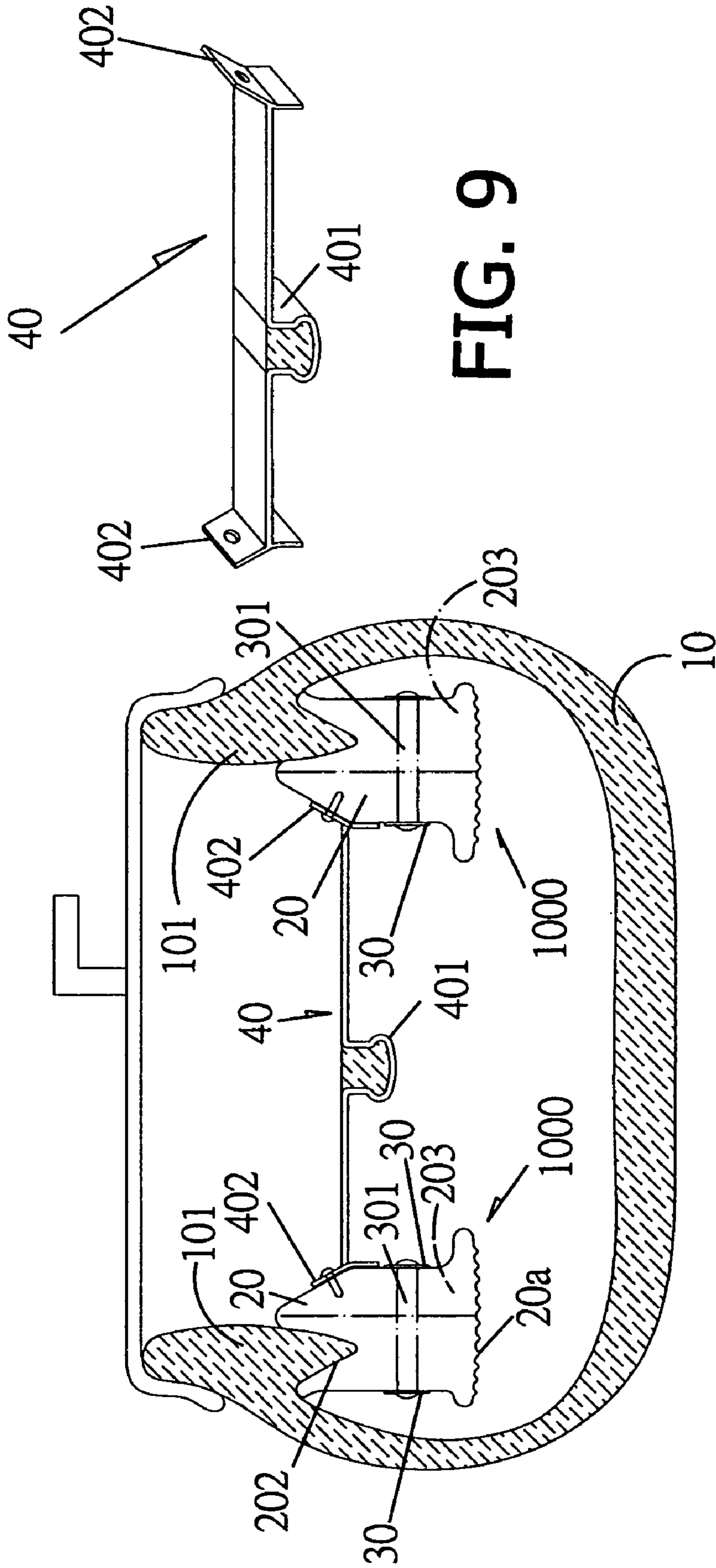

FIG. 9

FIG. 11



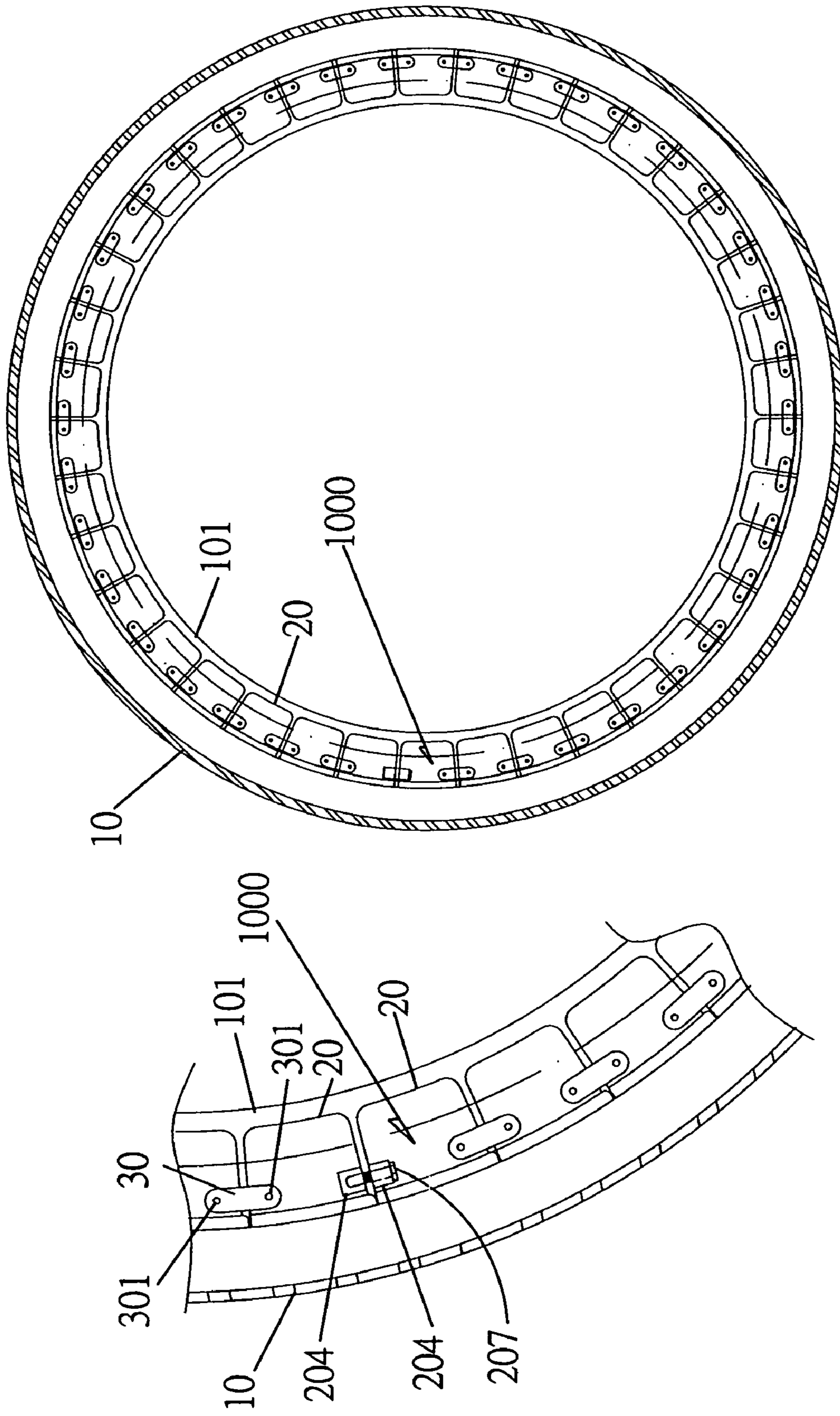

FIG. 10

## TIRE REINFORCING ARRANGEMENT

## BACKGROUND OF THE INVENTION

## 1. Field of the Invention

The present invention relates to vehicle tires and, more particularly, to such a vehicle tire, which is reinforced with inner spare tires.

## 2. Description of the Related Art

Conventional vehicle tires include two types, namely, the one with inner tube and the other without inner tube. A tire with an inner tube is inflatable. When the inner tube of a tire pierced by a pointed external object, it leaks, and the driver must stop the car immediately. A sudden explosion of a tire may cause a traffic accident when the car is running on a freeway. A tubeless tire or the so-called high-speed tire does not explode when pierced by a pointed external object, giving a sufficient time to let the driver drive the car to a garage for repair. However, because no significant tire pressure loss is shown when one tire of the car was pierced by a pointed external object, the driver may keep driving the car on a highway or freeway. In this case, an accident may occur.

Therefore, it is desirable to provide a tire reinforcing arrangement that eliminates the aforesaid problems.

## SUMMARY OF THE INVENTION

The present invention has been accomplished under the circumstances in view. It is the main object of the present invention to provide a tire reinforcing arrangement, which allows the car driver to keep driving the car safely for a certain period of time in case one tire of the tire is pierced by a pointed external object. It is another object of the present invention to provide a tire reinforcing arrangement, which is easy to install. It is still another object of the present invention to provide a tire reinforcing arrangement, which fits tires of different sizes.

To achieve these and other objects of the present invention, the tire reinforcing arrangement comprises an outer tire, outer tire comprising hooked flanges respectively extended along two opposite sidewalls thereof on the inside; two annular spare tires bilaterally set inside the outer tire, the annular spare tire each comprising a plurality of spare tire blocks, the spare tire blocks each comprising two mounting through holes transversely extended through two opposite sides thereof, a top locating groove adapted to receive the hooked flanges of the outer tire, an embossed bottom wall, and two projecting portions diagonally disposed at two ends, a plurality of links adapted to join the spare tire blocks, and a plurality of screw bolts respectively fastened to the mounting through holes to secure the links to the spare tire blocks; and a plurality of stretchers respectively stopped between the annular spare tires, the stretchers each having two end lugs respectively stopped against the annular spare tires, a U-shaped middle part, and a rubber bonded to the U-shaped middle part.

## BRIEF DESCRIPTION OF THE DRAWINGS

FIG. 1 is a sectional elevation of an outer tire according to the present invention.

FIG. 2 is an elevational view of a spare tire block according to the present invention.

FIG. 3 is a bottom view showing two spare tire blocks attached together according to the present invention.

FIG. 4 is an exploded view of a part of an annular spare tire according to the present invention.

FIG. 5 is schematic front and rear views of the spare tire block according to the present invention.

FIG. 6 is an exploded view showing the connection arrangement between the first spare tire block and the last spare tire block.

FIG. 7 is sectional front and rear views of the spare tire block according to the present invention.

FIG. 8 illustrates the top locating groove of the spare tire block bonded with rubber material.

FIG. 9 is an elevational view of a stretcher according to the present invention.

FIG. 10 is a schematic sectional view showing the tire reinforcing arrangement assembled according to the present invention.

FIG. 11 is a sectional view showing the tire reinforcing arrangement installed in a wheel rim according to the present invention.

## DETAILED DESCRIPTION OF THE PREFERRED EMBODIMENT

Referring to FIG. 1, an outer tire **10** is shown having two hooked flanges **101** respectively extended along the two opposite sidewalls thereof on the inside. The hooked flanges **101** have meshed screens (not shown) embedded therein to reinforce the strength.

Referring to FIGS. 2~6, spare tire blocks **20** are provided each having two mounting through holes **201** transversely extended through two opposite sides, a top locating groove **202** longitudinally disposed at the top, an embossed bottom wall **20a**, and two projecting portions **203** diagonally disposed at two ends. Links **30** are symmetrically disposed at two sides and respectively fastened to the mounting through holes **201** by screw bolts **301** to connect the spare tire blocks **20** in series, keeping one projecting portion **203** of each spare tire block **20** abutted against one projecting portion **203** of another. Further, the first and last ones of the connected series of spare tire blocks **20** each have a screw hole **204** extended in parallel to the top locating groove **202**, and a pinhole **206** or pin **205** at one end. By means of inserting the pin **205** of the last spare tire block into the pin hole **206** of the first spare tire block and the threading a screw **207** into the screw holes **204** of the first and last ones of the connected series of spare tire blocks, the spare tire blocks **20** are set to form an annular spare tire **1000**.

Referring to FIGS. 7 and 8, the spare tire blocks **20** are hollow block members made of high strength metal having a light weight (see FIG. 7). Rubber material may be directly molded on the top side of the spare tire blocks **20**, forming the designed top locating groove **202** (see FIG. 8).

Referring to FIG. 9, a narrow elongated stretcher **40** is shown having a substantially U-shaped middle part bonded with a rubber block **401** and two end lugs **402** at the ends.

Referring to FIGS. 10 and 11 and FIG. 6 again, two annular spare tires **1000** are bilaterally set into the inside of the outer tire **10**, and then the hooked flanges **101** of the outer tire **10** are respectively engaged into the top locating grooves **202** of the spare tire blocks **20**, and then a number of stretchers **40** are set in between the two annular spare tires **1000**.

By means of increasing or reducing the number of the spare tire blocks **20**, the size of the annular spare tires **1000** is set subject to the size of the outer tire **10** used.

## 3

Because the spare tire blocks **20** can be made through a mass production process, the manufacturing cost of the present invention is not high.

A prototype of tire reinforcing arrangement has been constructed with the features of FIGS. **1~11**. The tire reinforcing arrangement functions smoothly to provide all of the features discussed earlier.

Although a particular embodiment of the invention has been described in detail for purposes of illustration, various modifications and enhancements may be made without departing from the spirit and scope of the invention. Accordingly, the invention is not to be limited except as by the appended claims.

What the invention claimed is:

**1.** A tire reinforcing arrangement comprising:

an outer tire, said outer tire comprising hooked flanges respectively extended along two opposite sidewalls thereof on the inside;

two annular spare tires bilaterally set inside said outer tire, each annular spare tire including a plurality of spare tire

## 4

blocks, each spare tire block including (a) two mounting through holes transversely extended through two opposite sides thereof, (b) a top locating groove adapted to receive said hooked flanges of said outer tire, (c) an embossed bottom wall, and (d) two projecting portions diagonally disposed at two ends, a plurality of links adapted to respectively join said plurality of spare tire blocks, and a plurality of screw bolts respectively fastened to said mounting through holes to secure said links to said spare tire blocks; and

a plurality of stretchers respectively stopped between said annular spare tires, said stretchers each having two end lugs respectively stopped against said annular spare tires, a U-shaped middle part, and a rubber bonded to said U-shaped middle part.

\* \* \* \* \*