

US006979194B2

(12) **United States Patent**  
**Cao**

(10) **Patent No.:** **US 6,979,194 B2**  
(45) **Date of Patent:** **\*Dec. 27, 2005**

(54) **LIGHT FOR ACTIVATING LIGHT-ACTIVATED MATERIALS, THE LIGHT INCLUDING A PLURALITY OF INDIVIDUAL CHIPS AND PROVIDING A PARTICULAR SPECTRAL PROFILE**

(75) Inventor: **Densen Cao**, Sandy, UT (US)

(73) Assignee: **Cao Group, Inc.**, Sandy, UT (US)

(\*) Notice: Subject to any disclaimer, the term of this patent is extended or adjusted under 35 U.S.C. 154(b) by 302 days.

This patent is subject to a terminal disclaimer.

(21) Appl. No.: **10/189,224**

(22) Filed: **Jul. 3, 2002**

(65) **Prior Publication Data**

US 2002/0177099 A1 Nov. 28, 2002

**Related U.S. Application Data**

(63) Continuation-in-part of application No. 10/076,128, filed on Feb. 12, 2002, now Pat. No. 6,719,559, which is a continuation-in-part of application No. 10/073,672, filed on Feb. 11, 2002, which is a continuation-in-part of application No. 10/073,823, filed on Feb. 11, 2002, which is a continuation-in-part of application No. 10/073,822, filed on Feb. 11, 2002, which is a continuation-in-part of application No. 10/073,819, filed on Feb. 11, 2002, now Pat. No. 6,719,558, which is a continuation-in-part of application No. 10/071,847, filed on Feb. 6, 2002, which is a continuation-in-part of application No. 10/072,831, filed on Feb. 6, 2002, which is a continuation-in-part of application No. 10/072,852, filed on Feb. 6, 2002, which is a continuation-in-part of application No. 10/072,462, filed on Feb. 5, 2002, which is a continuation-in-part of application No. 10/072,858, filed on Feb. 5, 2002, which is a continuation-in-part of application No. 10/072,826, filed on Feb. 5, 2002, which is a con-

tinuation-in-part of application No. 10/072,635, filed on Feb. 5, 2002, which is a continuation-in-part of application No. 10/072,302, filed on Feb. 5, 2002, and a continuation-in-part of application No. 10/072,613, filed on Feb. 5, 2002, and a continuation-in-part of application No. 10/072,859, filed on Feb. 5, 2002, now Pat. No. 6,780,010, and a continuation-in-part of application No. 10/072,853, filed on Feb. 5, 2002, now Pat. No. 6,755,649, and a continuation-in-part of application No. 10/072,659, filed on Feb. 5, 2002, and a continuation-in-part of application No. 10/072,850, filed on Feb. 5, 2002, and a continuation-in-part of application No. 10/067,692, filed on Feb. 4, 2002, now Pat. No. 6,755,648, and a continuation-in-part of application No. 10/016,992, filed on Dec. 13, 2001, and a continuation-in-part of application No. 10/017,272, filed on Dec. 13, 2001, now Pat. No. 6,783,362, and a continuation-in-part of application No. 10/017,454, filed on Dec. 13, 2001, and a continuation-in-part of application No. 10/017,455, filed on Dec. 13, 2001, and a continuation-in-part of application No. 09/405,373, filed on Sep. 24, 1999, now Pat. No. 6,331,111.

(60) Provisional application No. 60/304,324, filed on Jul. 10, 2001.

(51) **Int. Cl.<sup>7</sup>** ..... **A61C 1/00**

(52) **U.S. Cl.** ..... **433/29; 362/800**

(58) **Field of Search** ..... 433/29, 215; 606/1, 606/13, 16; 607/88; 362/119, 800, 804

(56) **References Cited**

**U.S. PATENT DOCUMENTS**

|             |         |                   |            |
|-------------|---------|-------------------|------------|
| 4,149,086 A | 4/1979  | Nath              | 250/504    |
| 4,184,196 A | 1/1980  | Moret et al.      | 433/29     |
| 4,229,658 A | 10/1980 | Gonser            | 250/504    |
| 4,281,366 A | 7/1981  | Wurster et al.    | 362/32     |
| 4,308,120 A | 12/1981 | Pennewiss et al.  | 204/159.23 |
| 4,698,730 A | 10/1987 | Sakai et al.      | 362/311    |
| 4,839,566 A | 6/1989  | Herold et al.     | 31/308     |
| 4,936,776 A | 6/1990  | Kwiatkowski       | 433/220    |
| 5,139,495 A | 8/1992  | Daikuzono         | 606/17     |
| 5,151,520 A | 9/1992  | Gottschalk et al. | 548/110    |

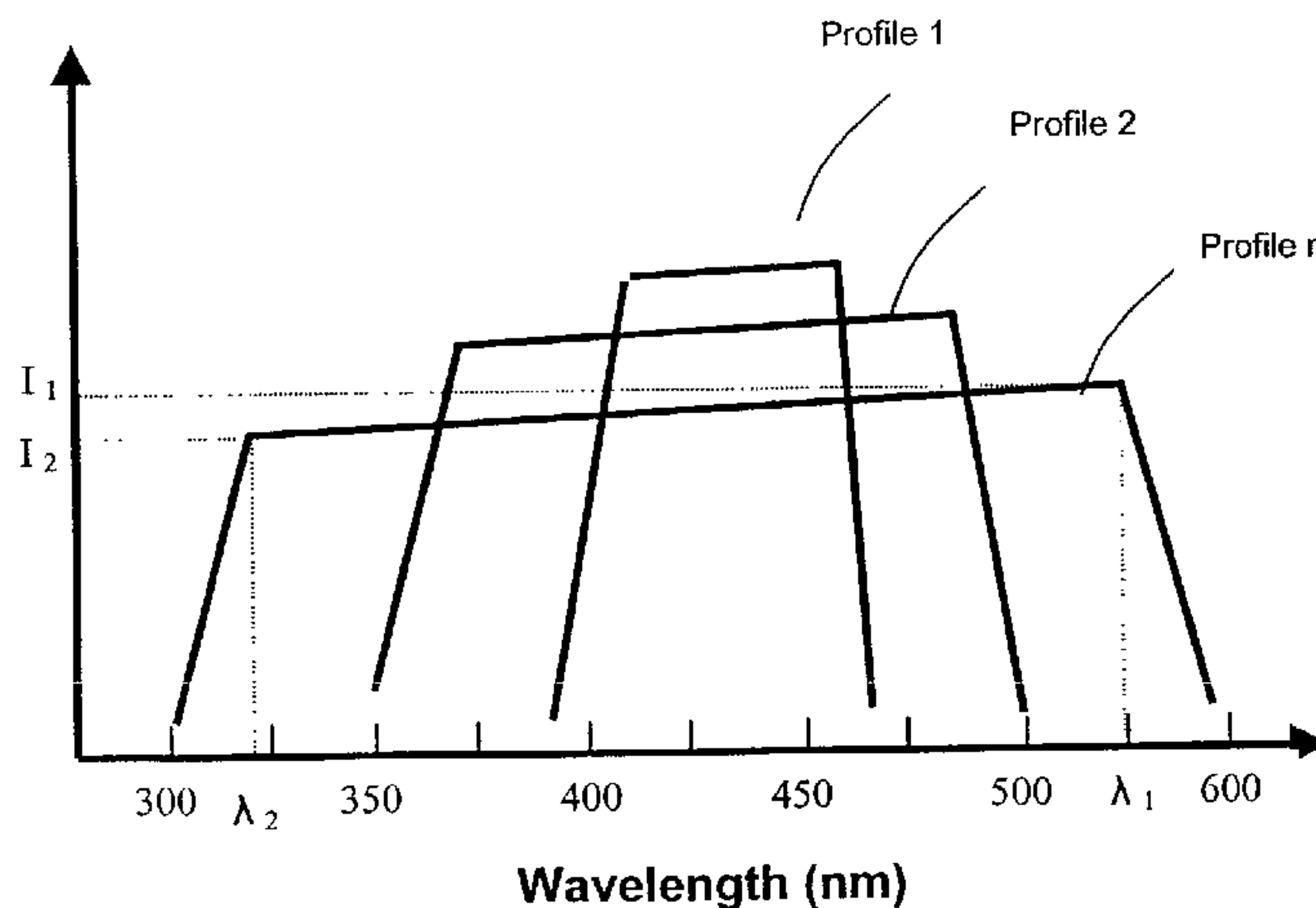



|                |         |                          |           |
|----------------|---------|--------------------------|-----------|
| 5,238,744 A    | 8/1993  | Williams et al. ....     | 428/412   |
| 5,348,552 A    | 9/1994  | Nakajima et al. ....     | 606/13    |
| 5,350,834 A    | 9/1994  | Bobsein et al. ....      | 528/485   |
| 5,457,611 A    | 10/1995 | Verderber .....          | 362/32    |
| 5,485,317 A    | 1/1996  | Perissinotto et al. .... | 359/712   |
| 5,521,392 A    | 5/1996  | Kennedy et al. ....      | 250/492.1 |
| 5,634,711 A *  | 6/1997  | Kennedy et al. ....      | 362/119   |
| 5,660,461 A    | 8/1997  | Ignatius et al. ....     | 262/241   |
| 5,711,665 A    | 1/1998  | Adam et al. ....         | 433/9     |
| 5,782,553 A    | 7/1998  | McDermott .....          | 362/245   |
| 5,791,898 A    | 8/1998  | Maissami .....           | 433/164   |
| 5,797,740 A    | 8/1998  | Lundvik .....            | 433/29    |
| 5,908,294 A    | 6/1999  | Schick et al. ....       | 433/29    |
| 5,908,295 A    | 6/1999  | Kawata .....             | 433/29    |
| 5,912,470 A    | 6/1999  | Eibofner et al. ....     | 250/504 H |
| 6,008,264 A    | 12/1999 | Ostler et al. ....       | 522/4     |
| 6,089,740 A    | 7/2000  | Forehand et al. ....     | 362/573   |
| 6,099,520 A *  | 8/2000  | Shimoji .....            | 606/2     |
| 6,103,203 A    | 8/2000  | Fischer .....            | 422/186   |
| 6,200,134 B1   | 3/2001  | Kovac et al. ....        | 433/29    |
| 6,208,788 B1   | 3/2001  | Nosov .....              | 385/121   |
| 6,328,456 B1   | 12/2001 | Mize .....               | 362/311   |
| 6,331,111 B1 * | 12/2001 | Cao .....                | 433/29    |
| 6,554,463 B2 * | 4/2003  | Hooker et al. ....       | 362/555   |
| 6,692,250 B1 * | 2/2004  | Decaudin et al. ....     | 433/29    |
| 6,692,251 B1 * | 2/2004  | Logan et al. ....        | 433/29    |
| 6,719,559 B2 * | 4/2004  | Cao .....                | 433/29    |
| 6,755,648 B2 * | 6/2004  | Cao .....                | 433/29    |
| 6,755,649 B2 * | 6/2004  | Cao .....                | 433/29    |
| 6,780,010 B2 * | 8/2004  | Cao .....                | 433/29    |
| 6,783,362 B2 * | 8/2004  | Cao .....                | 433/29    |

FOREIGN PATENT DOCUMENTS

|    |                |          |       |           |
|----|----------------|----------|-------|-----------|
| DE | 29 27 260 A1   | 2/1980   | ..... | A61N 5/06 |
| DE | 25 57 920 B2   | 3/1980   | ..... | A61C 5/04 |
| EP | 0 339 841 B1   | 2/1989   | ..... | C08F 2/50 |
| EP | 1 090 608 A1 * | 4/2001   |       |           |
| GB | 1 570 507      | 12/1976  | ..... | A61N 5/06 |
| WO | WO 99/161136   | * 4/1999 |       |           |

OTHER PUBLICATIONS

Guido Goracci, Giovanni Mori, Luca Casa de Martinis, "Curing light Intensity and marginal leakage of resin composite restorations", Quintessence International, vol. 27, No. 5/1995 (8 pages).

Hiromasa Kato, "Relationship between the velocity of polymerization and adaptation to dental cavity wall of light cured composites", Dental materials journal 6(1):32-37 (1987) (6 pages).

Uno, S., Asmussen, E., "Selected variables in bonding to dentin", Scand. J. Dent. Res. 1992: 100: 130-2 (2 pages).

G.L. Unterbrink and R. Muessner, "Influence of light intensity on two restorative systems", J. Dent, vol. 23, No. 3, pp. 183-189 (1995) (7 pages).

U.S. Appl. No. 10/180,489, filed Feb. 22, 2002, Fischer et al., Light-Curing Device with Detachably Interconnecting Light Application.

U.S. Appl. No. 10/068,397, filed Feb. 5, 2002, Fischer et al., Curing Light with Plurality of LED's and Corresponding Lenses.

U.S. Appl. No. 10/068,103, filed Feb. 5, 2002, Fischer et al., Lightweight Hand Held Dental Curing Devices.

U.S. Appl. No. 10/044,346, filed Jan. 11, 2002, McLean et al., Optical Lens Used to Focus LED Light.

U.S. Appl. No. 10/024,110, filed Dec. 17, 2001, Scott., Heat Sink with Geometric Arrangement of LED Surfaces.

Email from Jens Jenkins [Jjenkins@wnspat.com] to Dan McCarthy Re: Pending Application Information dated Wednesday, Apr. 3, 2002 (2 pages) and listing 5 pending U.S. patent applications.

10 Mississippi and you're done! New NRG LED Curing Light brochure from Dentsply Caulk (4 pages).

Exelite advertisement from Toesco (1 page).

Epilar Freelight advertisement from ESPE (1 page).

Centrix The Catalog for the Dental Professional showing Versalux LED curing light (1 page).

Introducing the Apoloe e light wireless curing light advertisement for LED curing light from DMD (1 page).

LumaCure New Technology World's first patented solid state Dental Curing Light (1 page).

Starlight and Starlight p by Mectron Medical Technology (1 page).

ZAP Dual Curing—A curing light that can Fast Cure with Soft Cure results? From Soft Core Texas, Inc. (1 page).

Polymerisation im Schongang Epilar Highlight from ESPE (6 pages).

Dentistry Today, Jan. 1998, front page and p. 70 showing Kreativ Inc. Kreativ Kuring Light (2 pages total).

Dental Products Report, Oct. 1997, front page and page showing ESPE Pentamix and Epilar Highlight (2 pages total).

Dental Products Report, Nov. 1997, front page and page showing Kreativ Microdentistry System (2 pages total).

Dental Cadmos 7/93, pp. 62 & 63.

A. Mehl, M. Sobota, R. Hickel, "Softstartpolymerisation von Kompositen in Klasse V Kavitäten", Dtsch Zahnarzl Z 52 (1997) in German (4 pages).

G. Goracci, L. Casa de Martinis, G. Mori, "Compositi e Polymerizzazione Lenta", Dental Dadmos 13/92 in Italian (12 pages).

G. Goracci, L. Casa de Martinis, G. Mori, "Polymerizzazione di Materiali Compositi", Dental Dadmos 7/93 in Italian (14 pages).

J. Reinhardt and J. Vahl Munster, "Unsicherheiten bei der Prufung von Photopolymerisaten", Dtsch Zahnarzl Z. 36, 635-640 (1981) in German.

Letter from John Vickers, III, General Counsel to American Dental Technologies, to Daniel MCarthy dated May 2, 2000.

Letter from Dr. Roland Brem of ESPE Dental AG to Daniel McCarthy dated May 11, 2000.

Letter from Dr. Roland Brem of ESPE Dental AG to Daniel McCarthy dated May 31, 2000.

Letter from Dr. Roland Brem of ESPE Dental AG to Daniel McCarthy dated Jun. 8, 2000.

Facsimile dated Friday, May 29, 1998 from Dr. Frederick M. Parkins of the School of Dentistry, University of Louisville to Bob Dalton of ADT regarding final draft sent to Tony Angelini (6 pages).

A. Mehl, H. Staunau, D. Schreyger, K.H. Kunzelmann, R. Hickel, LMU University Dental School, D-80336 Munich Germany, 1 page abstract, Journal of Dental Research, vol. 74, 1995, special issue p. 462.

Sakaguchi and Berge, "Light Intensity Effects on Degree of Cure Posterior Composite", #1972, IADR 1997 (4 pages).

Shigero Uno and Erik Asmussen, "Marginal Adaptation of A Restorative Resin Polymerized At A Reduced Rate" (5 pages).

Peter Koran & Ralf Kurschner, Effect of sequential versus continuous irradiation of a light cured resin composite on shrinkage, viscosity, adhesion, and degree of polymerization, CE Article #3-198, American Journal of Dentistry, vol. 11, No. 1, Feb. 1998 (6 pages).

A. Mehl, R. Hickel, K.H. Kunzelmann, Dental School Munich Germany, "Physical properties and gap formation of light cured composites with and without softstart-polymerization" faxed copy dated May 30, 1996 (27 pages).  
K.J. Reinhardt and J. Vahl, "Uncertainties in the Testing of Photopolymers" 11 pages.

A.J. Fellzer, L.H. Dooren, A.J. de Gee, and C.L. Davidson, "Influence of light intensity on polymerization shrinkage and Integrity of restoration cavity interface", Eur J. Oral Sci. 1995; 103: 322-326 (5 pages).

A. Mehl, M. Sobota, R. Hickel, "Soft start polymerization of composites in class V cavities" (10 pages).

Saliha S. Davidson-Kaban, Carel L. Davidson, Albert J. Feilzer, Anton J. de Gee, Nejdet Erdilek, "The effect of

curing light variations on bulk curing and wall to wall quality of two types and various shades of resin composites", Dent Mater 12:344-352, Nov. 1997 (9 pages).

\* cited by examiner

*Primary Examiner*—Ralph A. Lewis

(74) *Attorney, Agent, or Firm*—Daniel P. McCarthy; Parsons Behle & Latimer

(57)

**ABSTRACT**

Light system useful for activating light-activated materials are disclosed. Various configurations of light emitting semiconductor chips and heat sinks are disclosed, as well as various structures and methods for driving, controlling and using them, and materials and structures usable therewith.

**18 Claims, 46 Drawing Sheets**

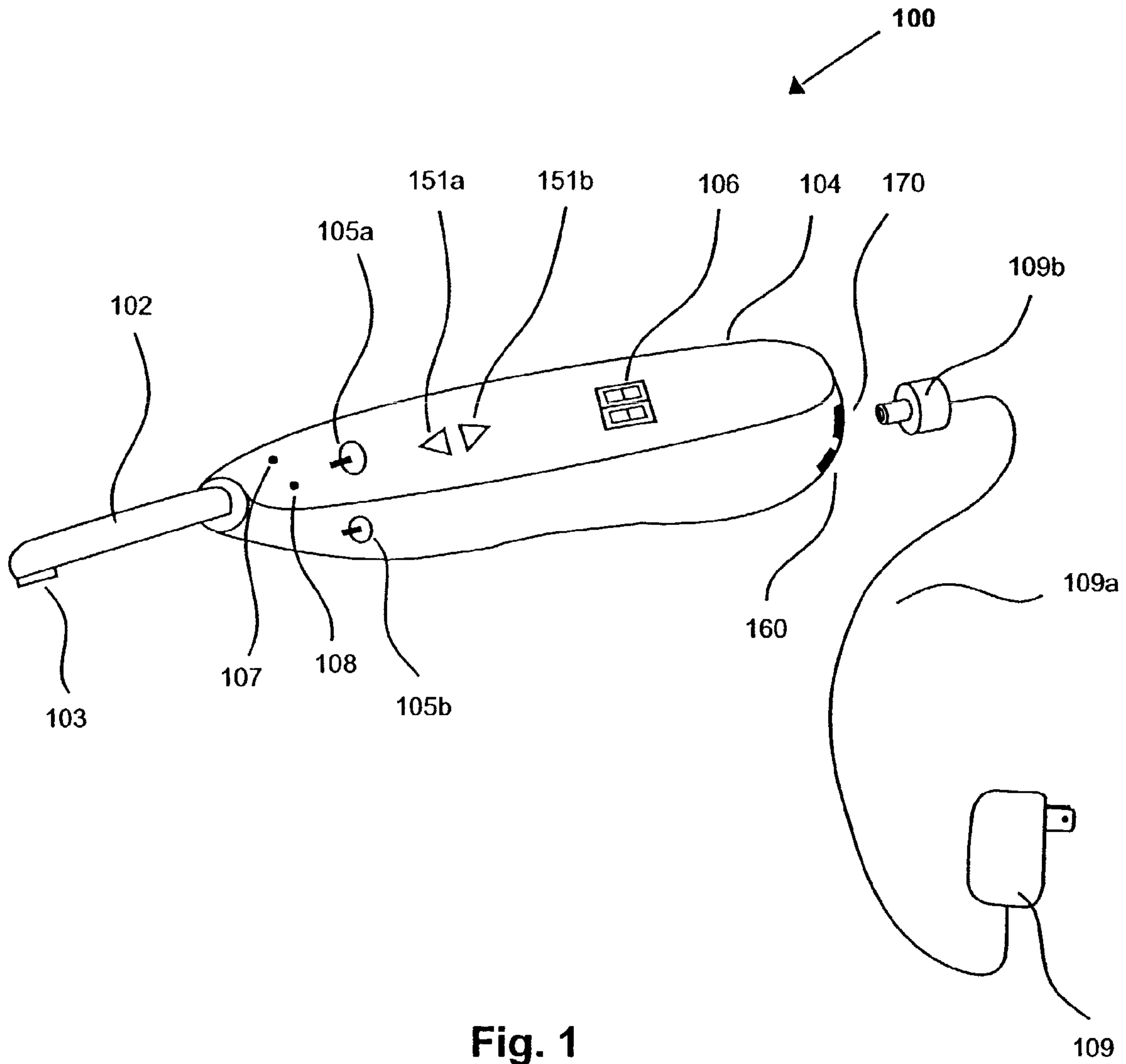

Fig. 1



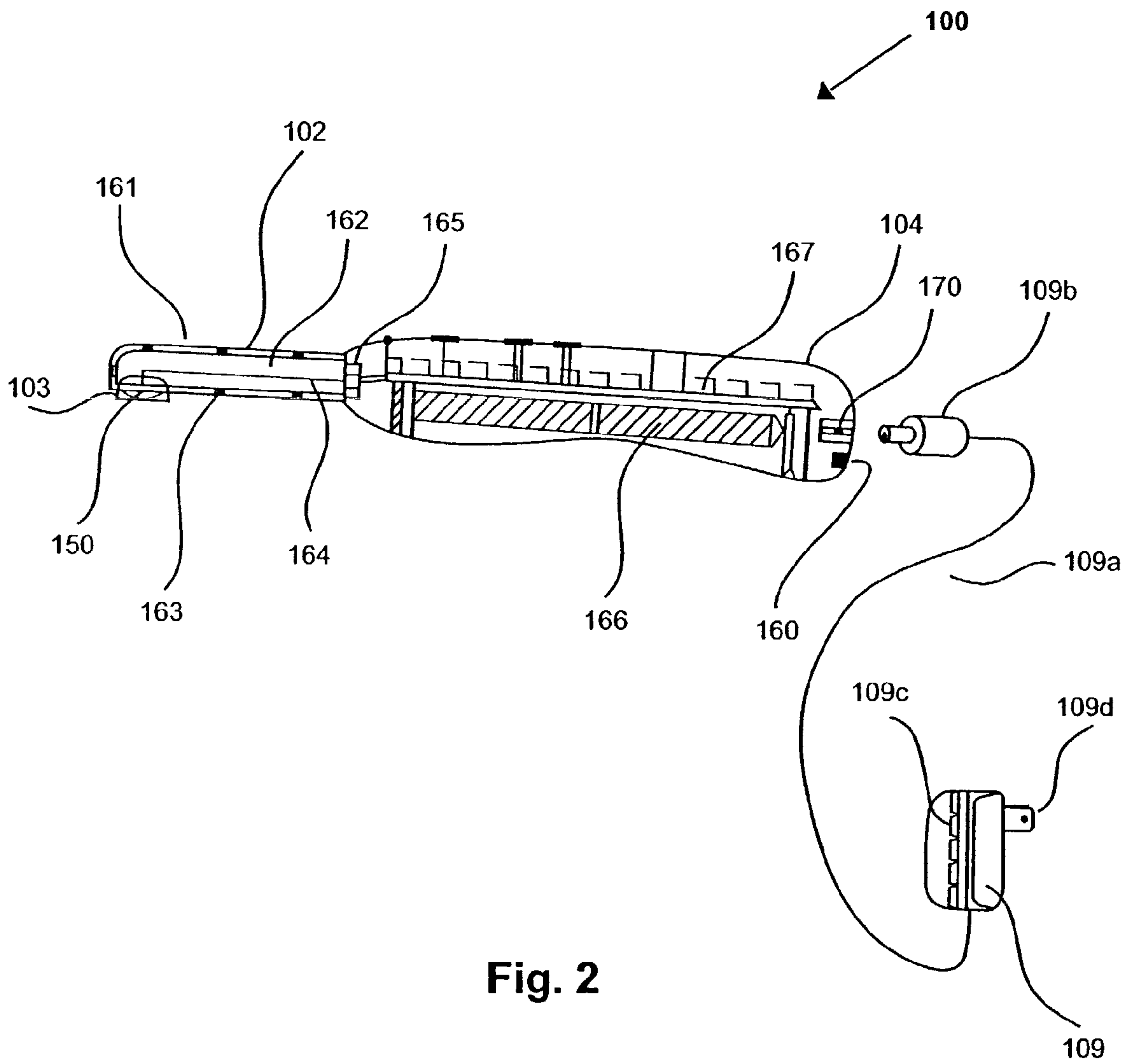

Fig. 2

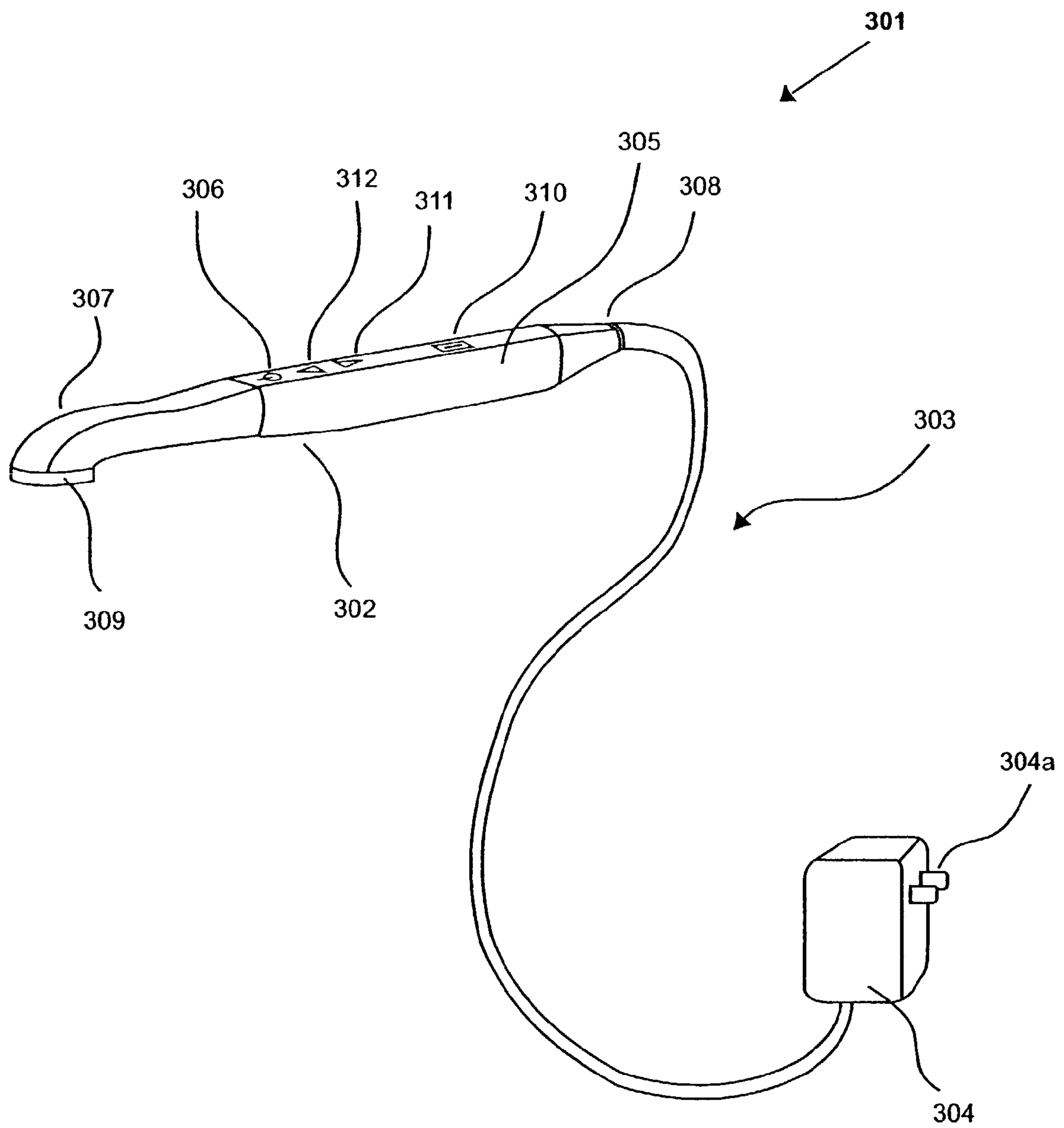

Fig. 3

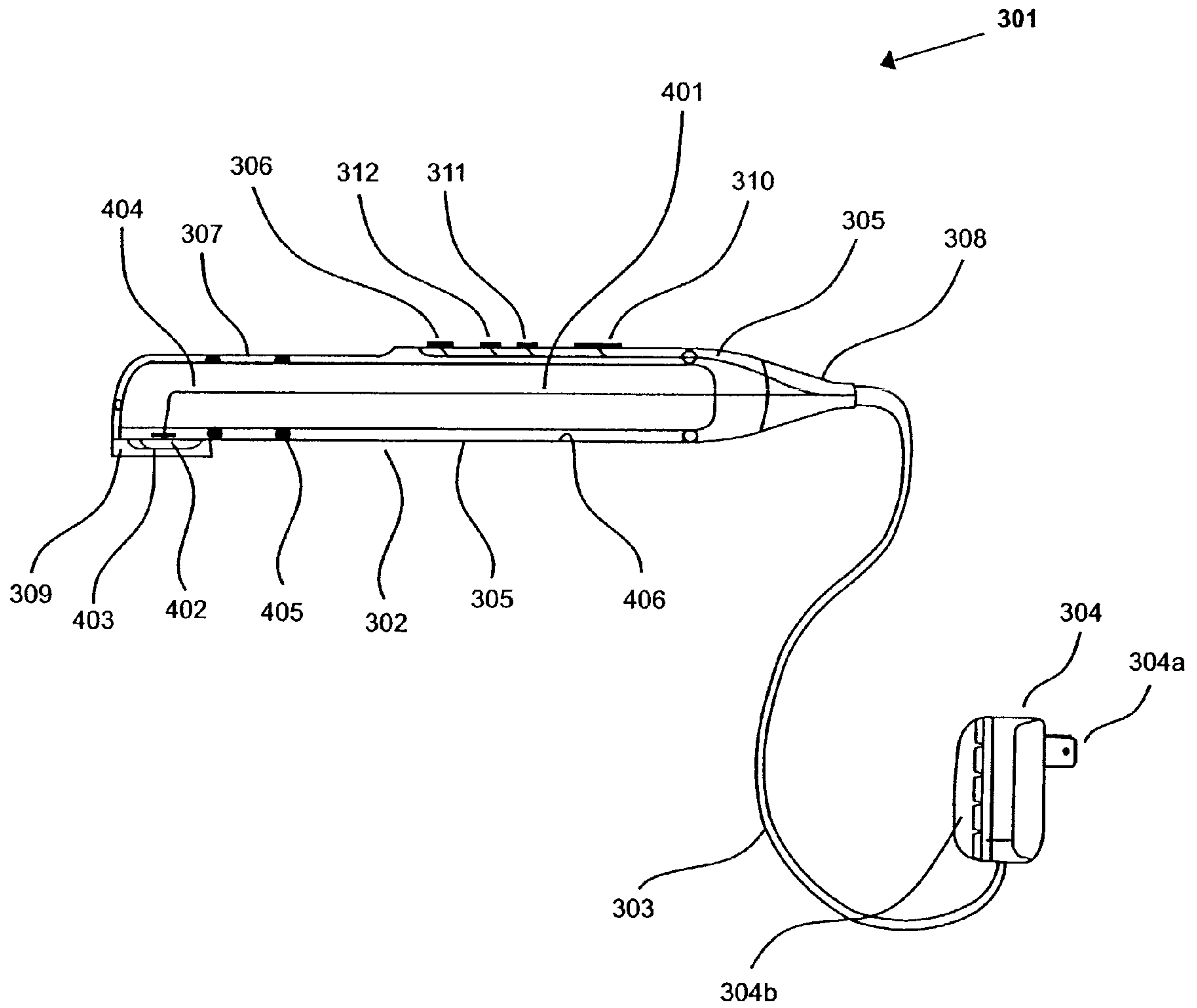

Fig. 4

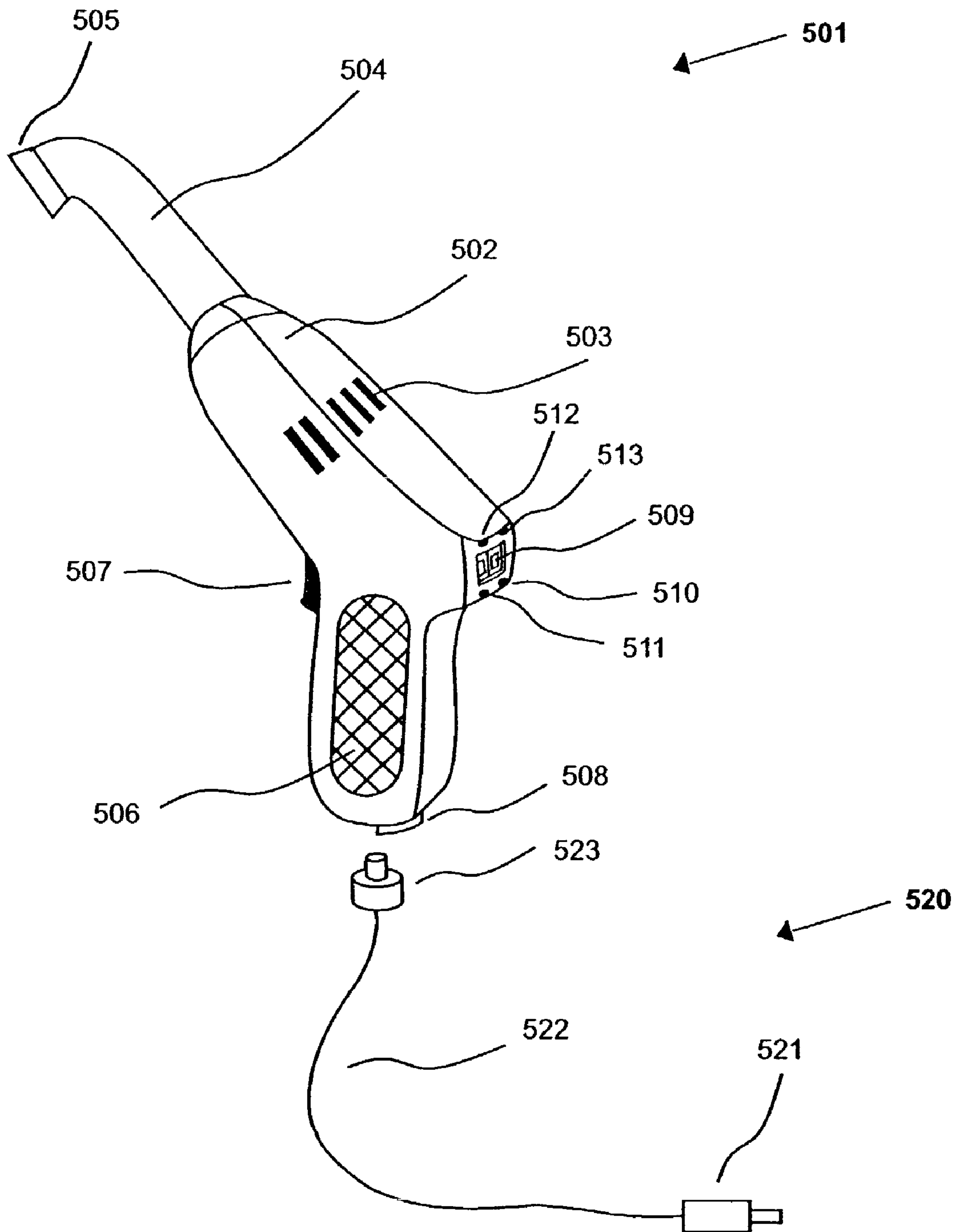

Fig. 5



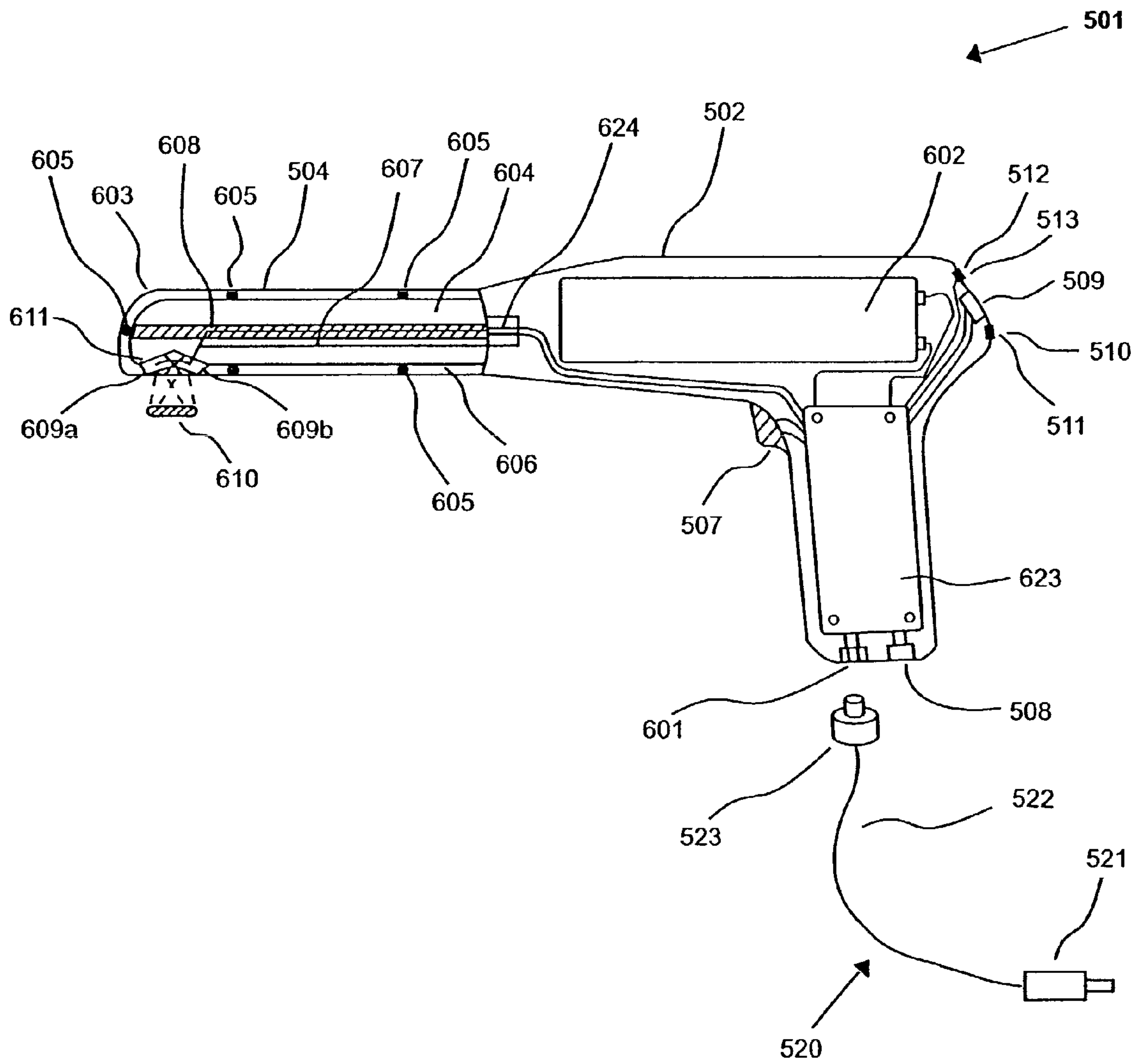

Fig. 6

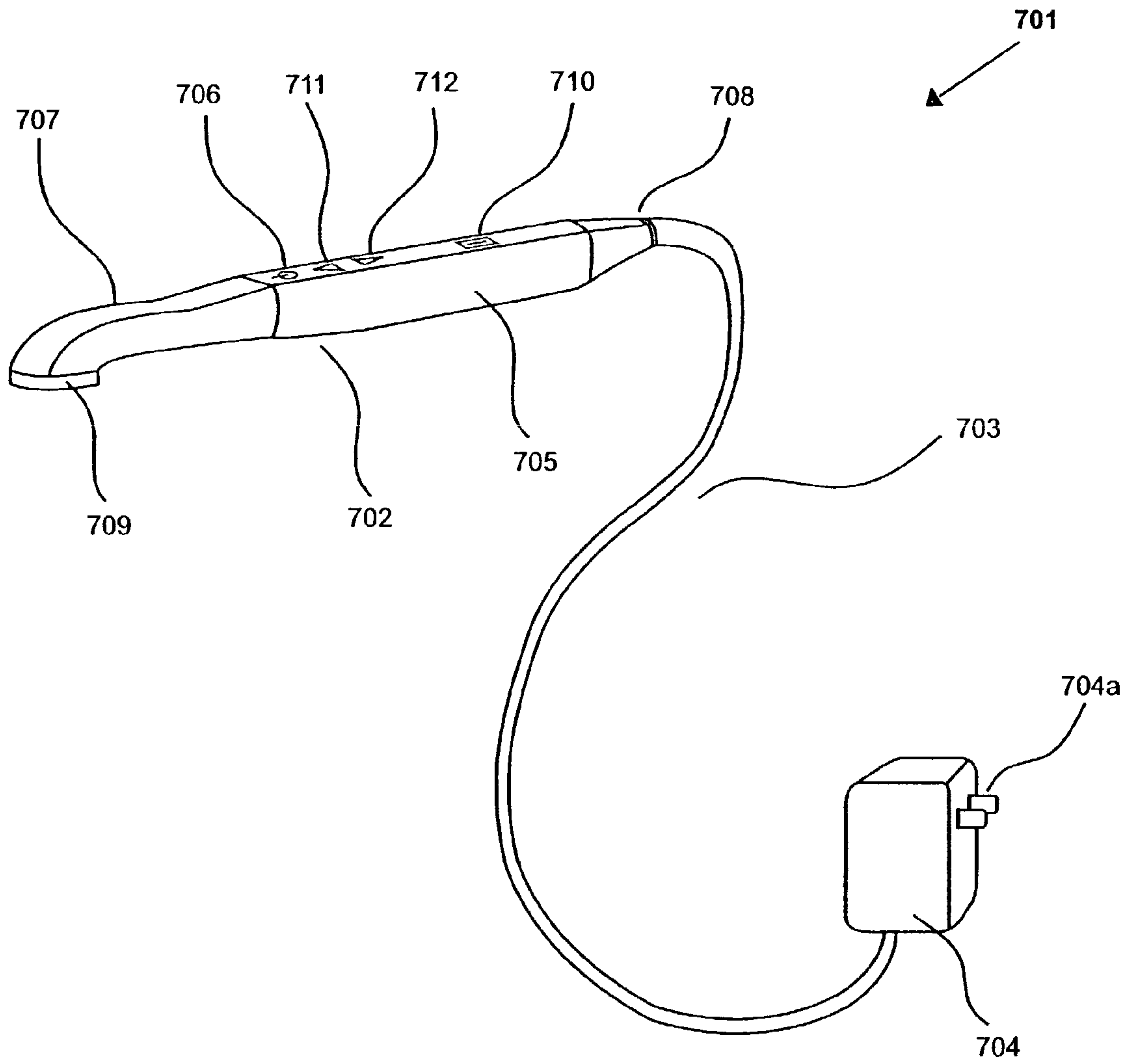

Fig. 7

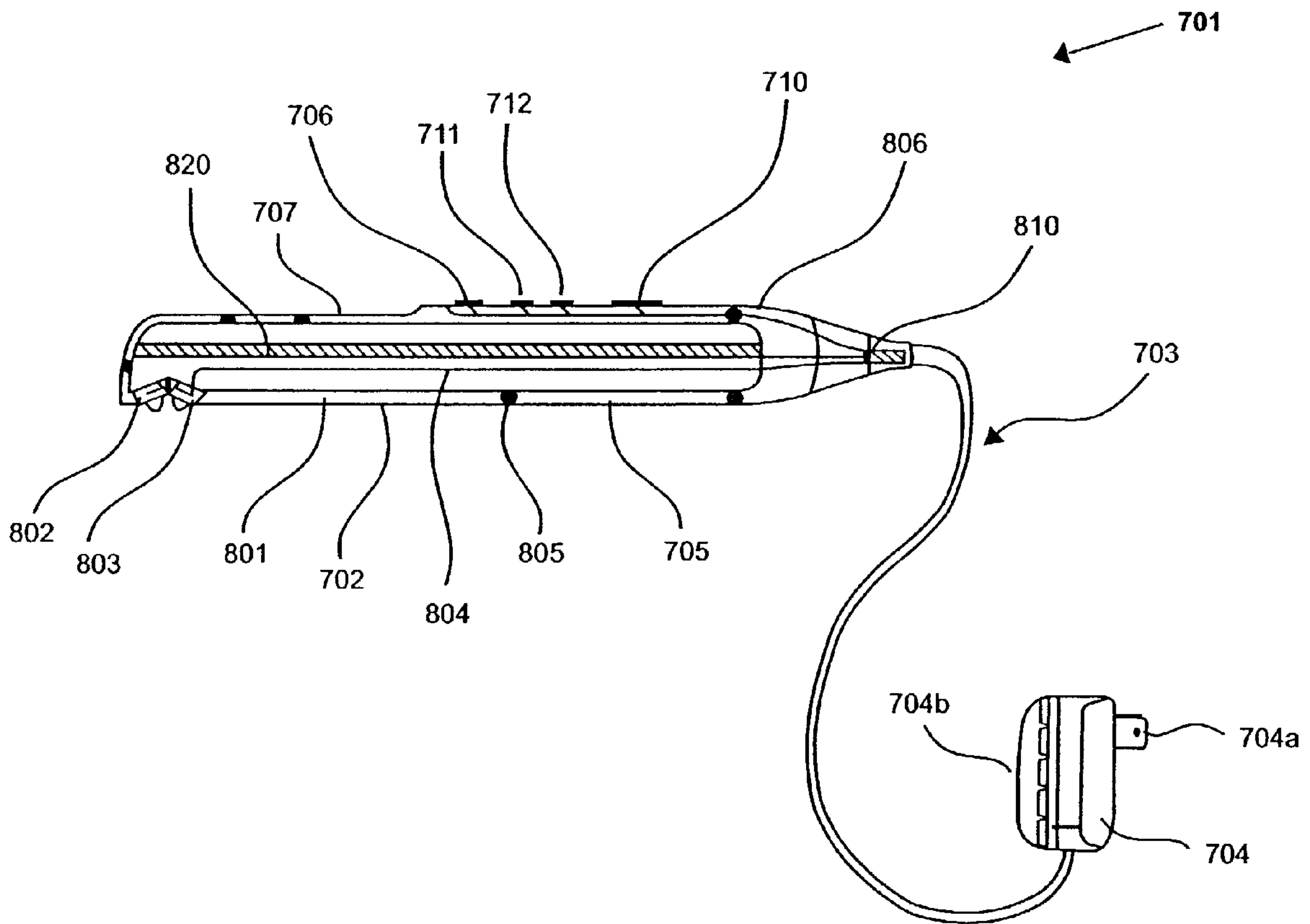

Fig. 8

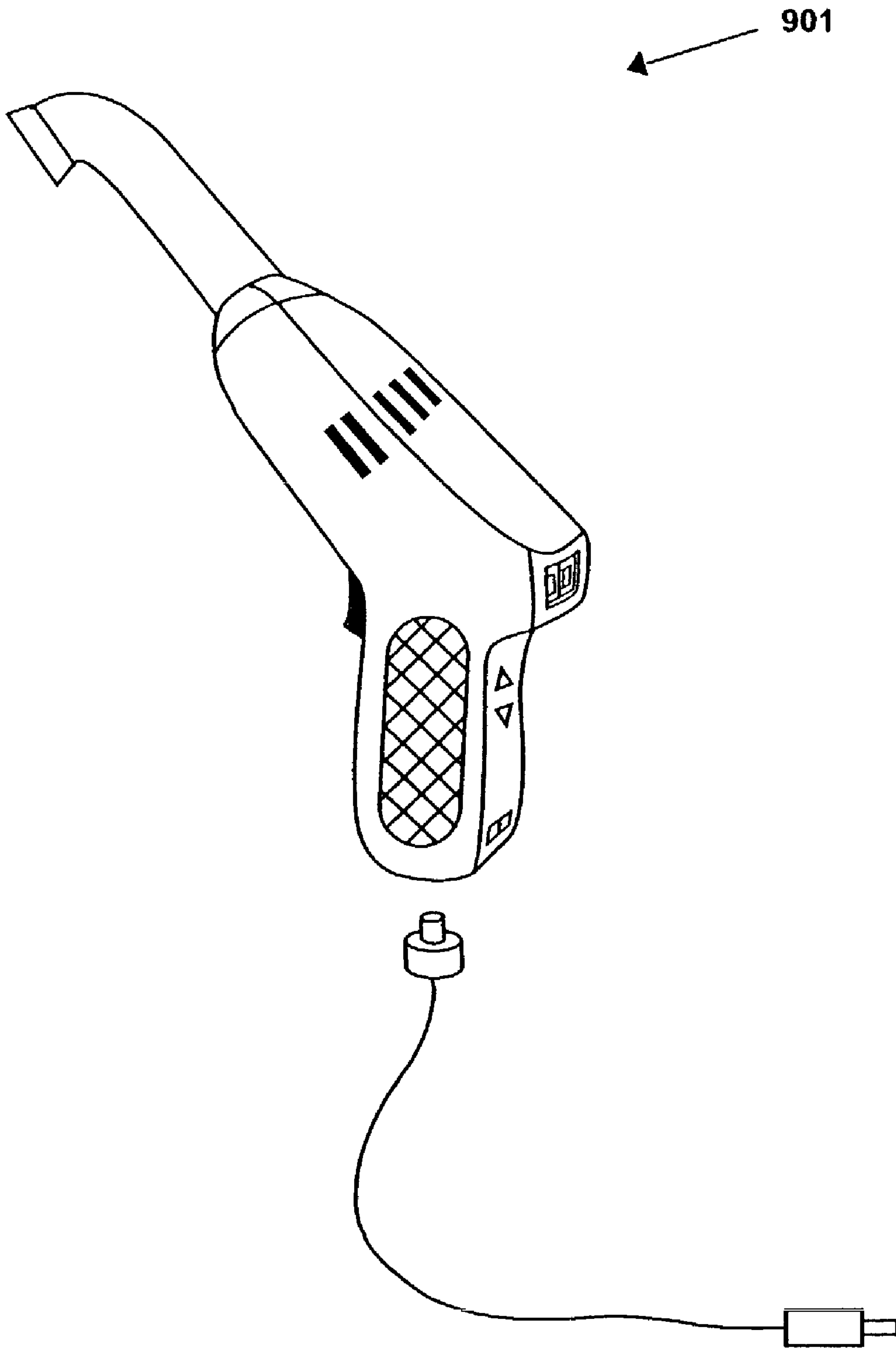

Fig. 9



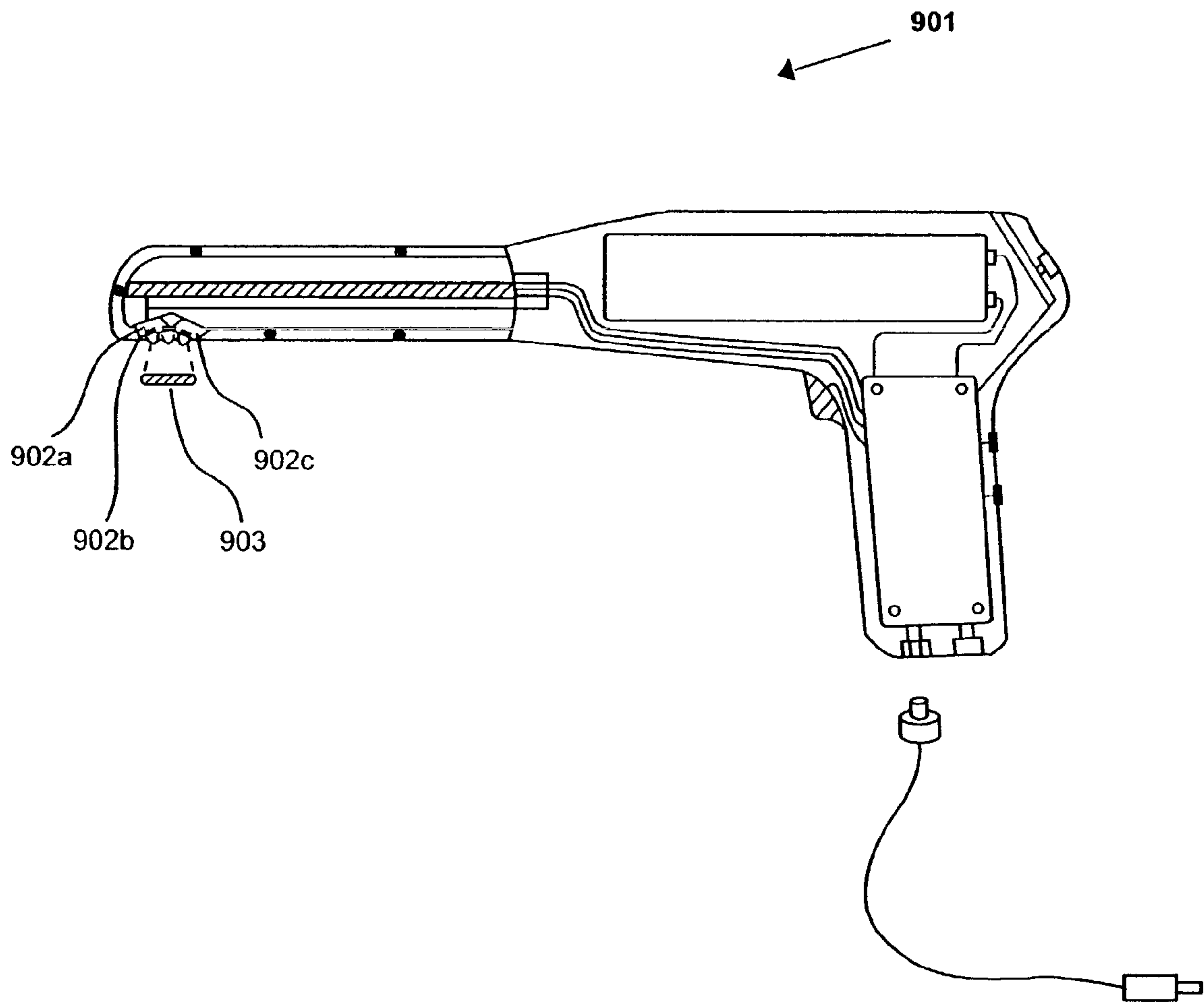

Fig. 10

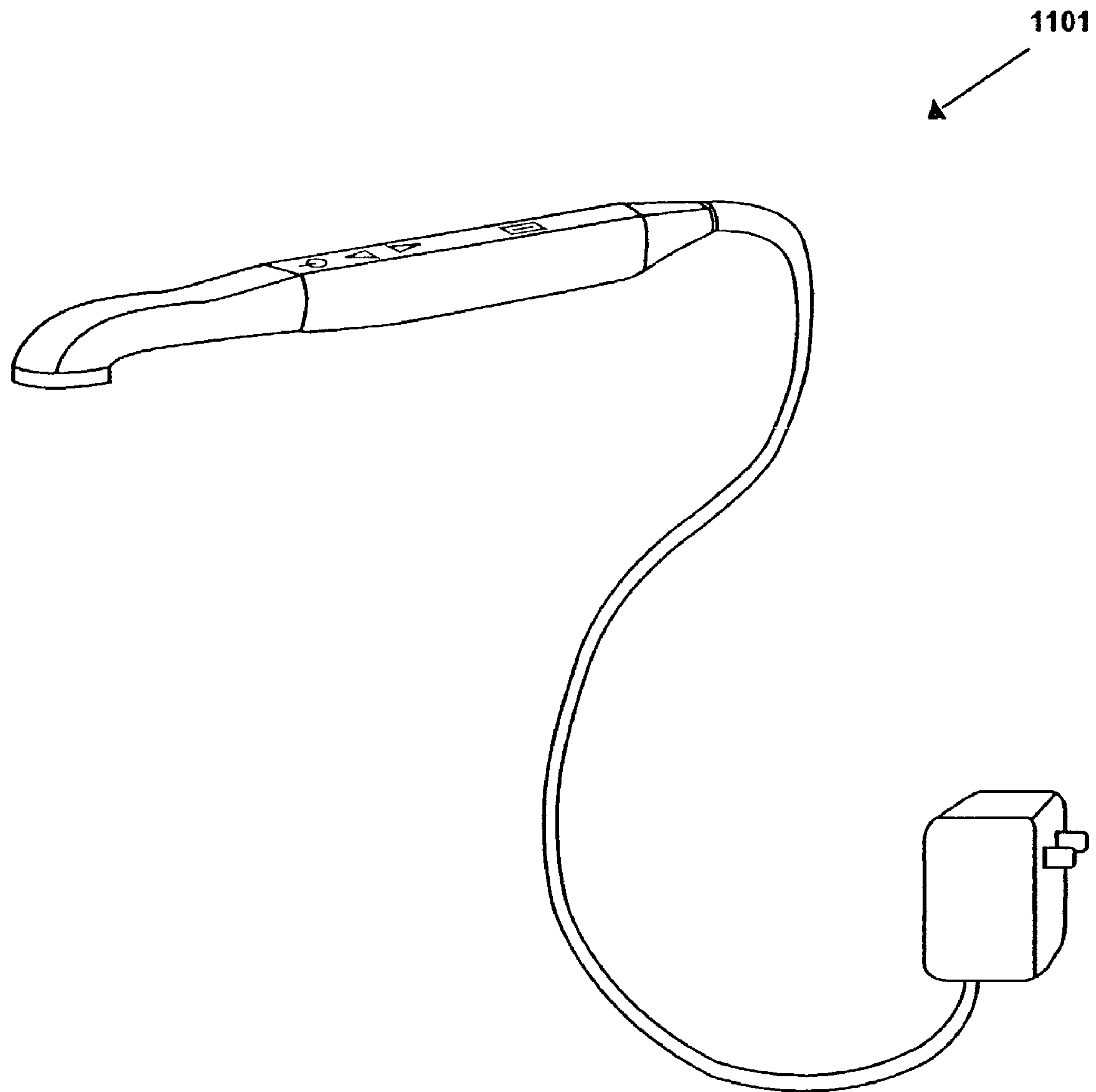

Fig. 11

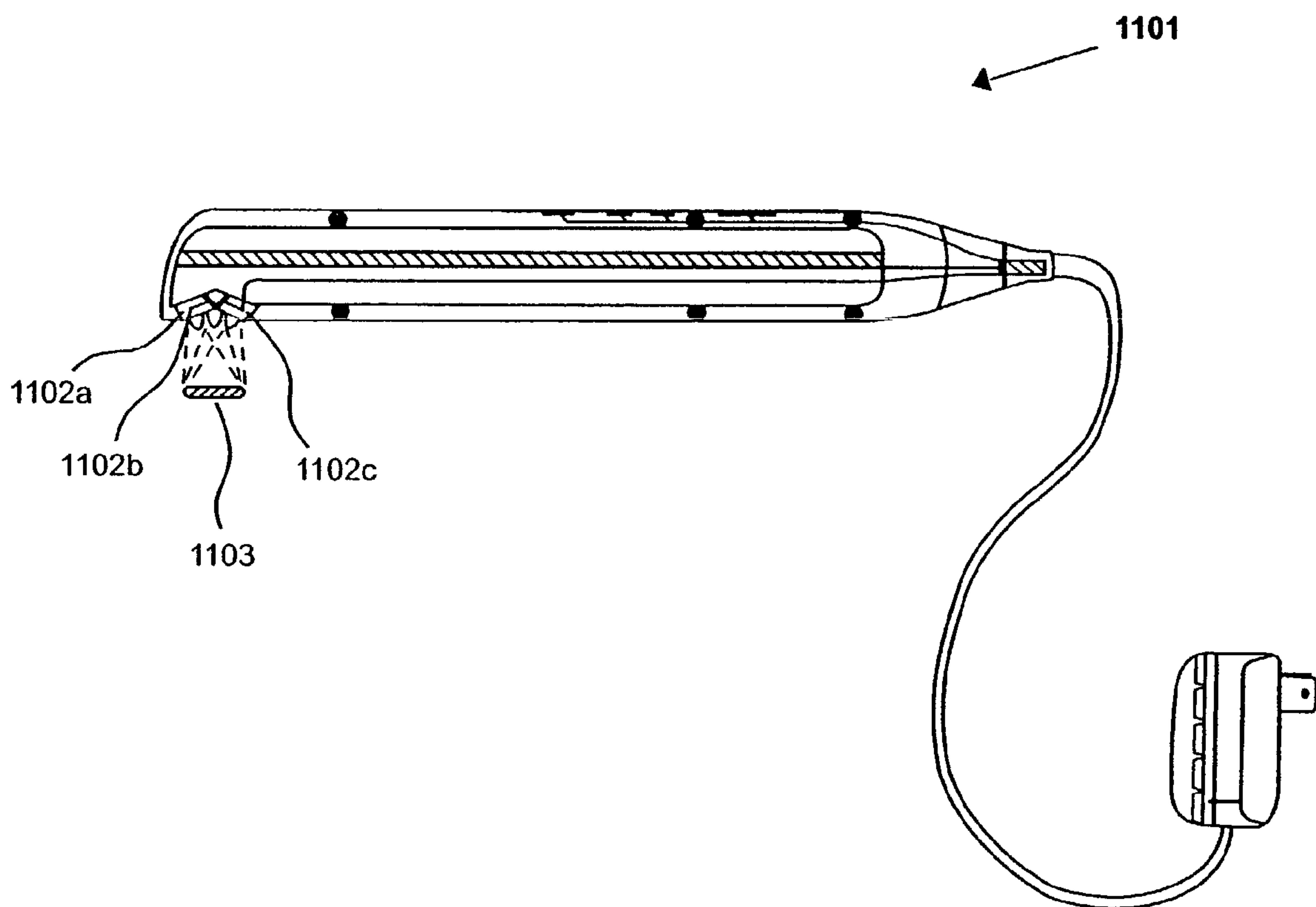

Fig. 12

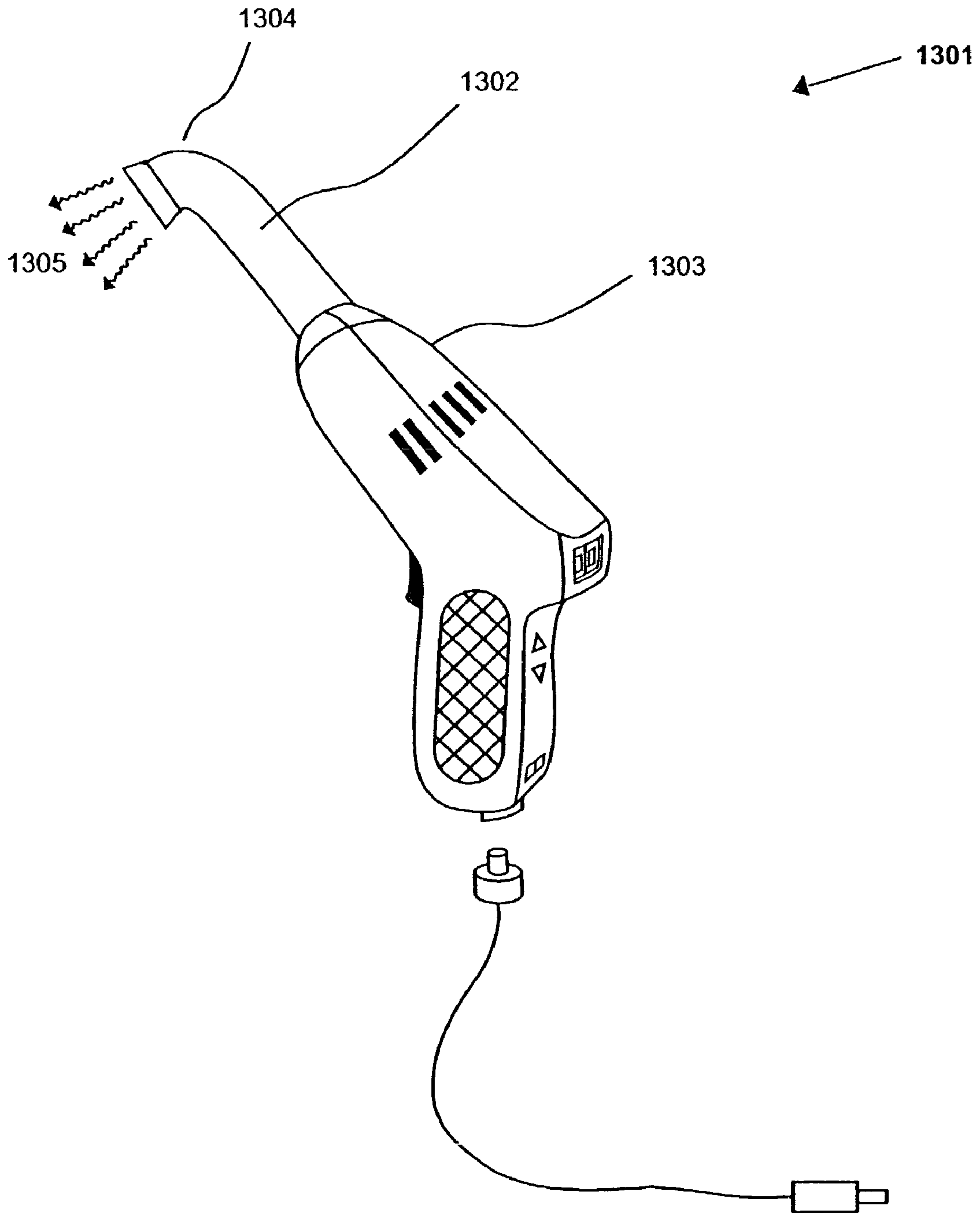

Fig. 13



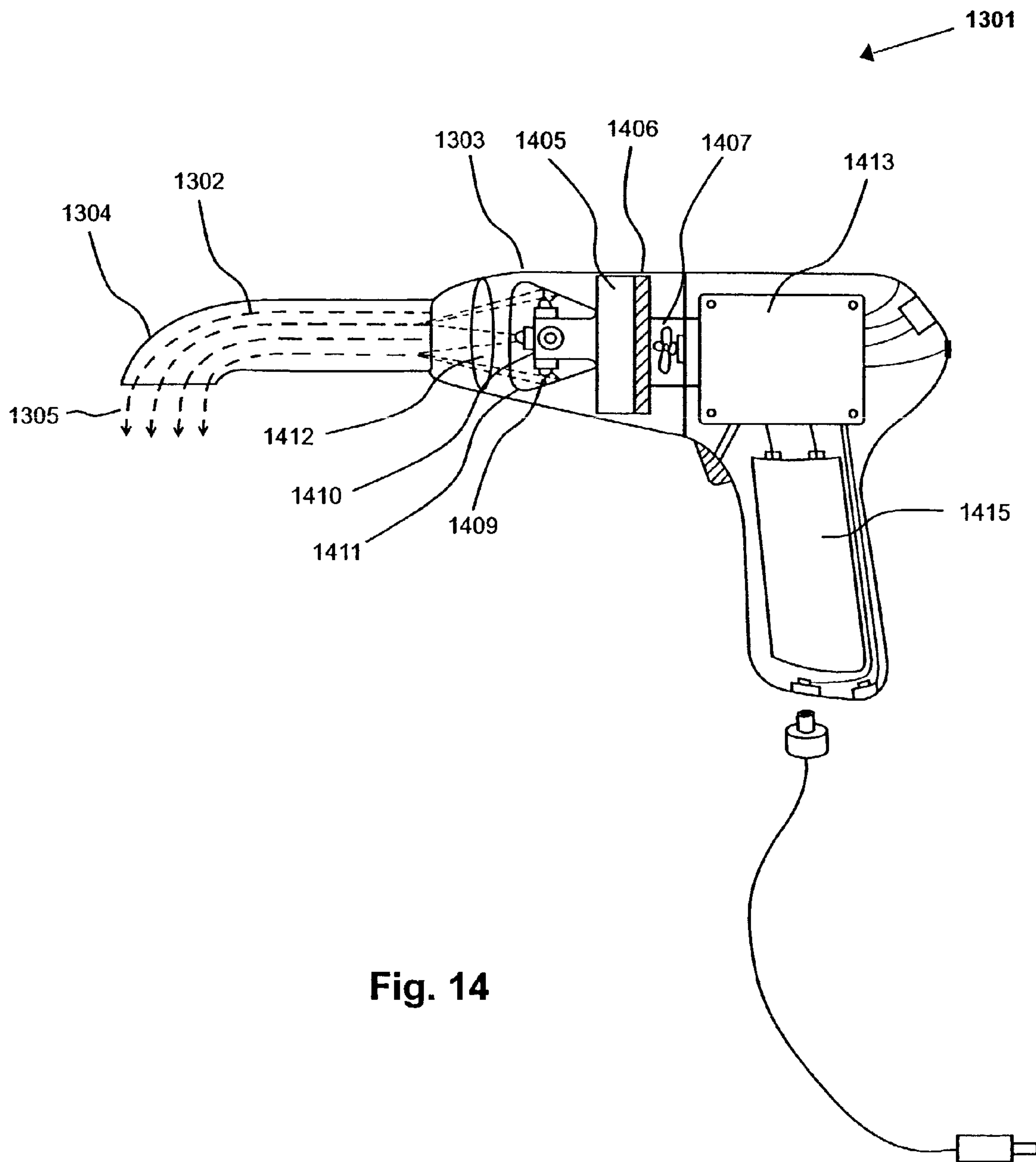

Fig. 14

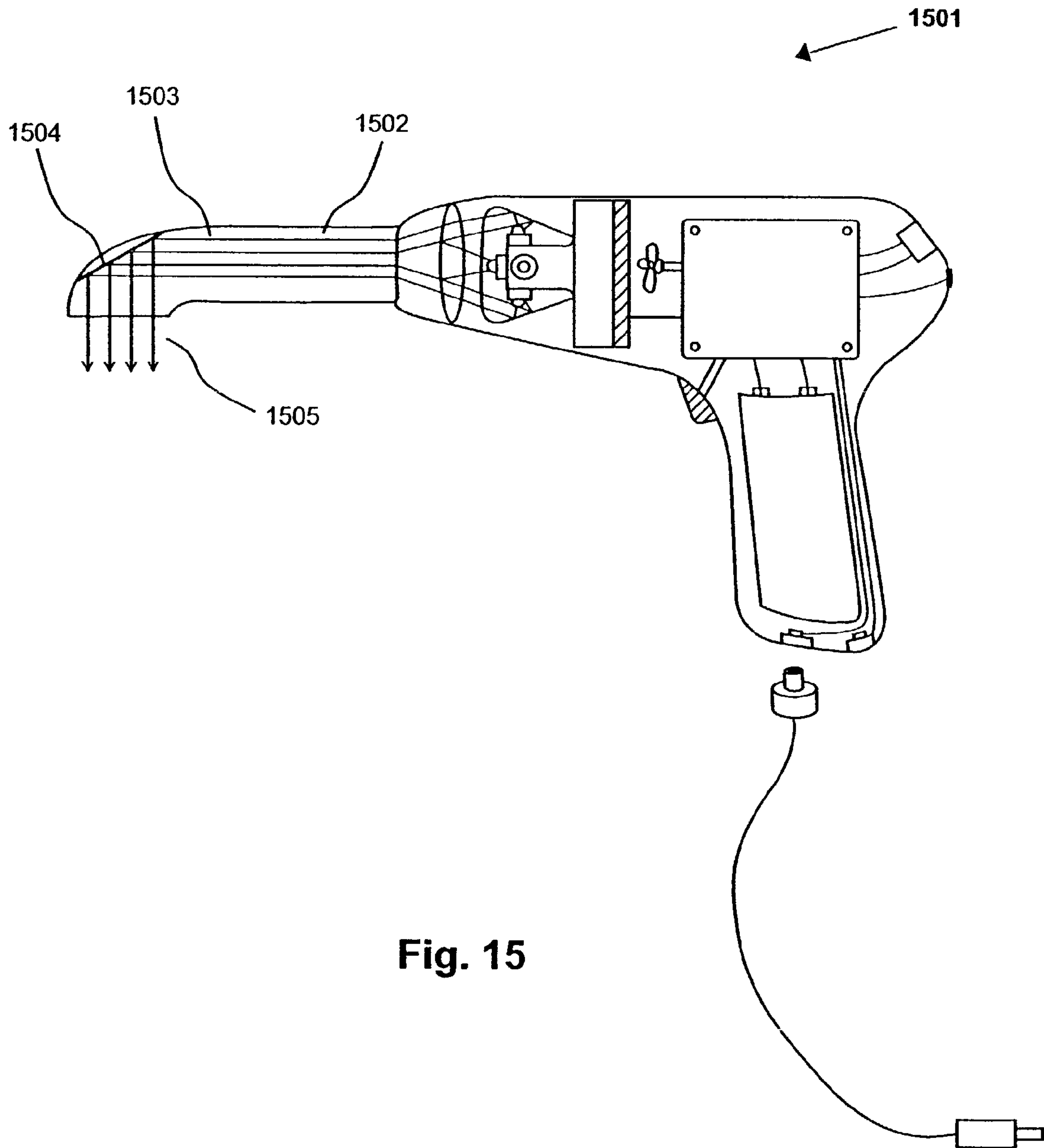

Fig. 15

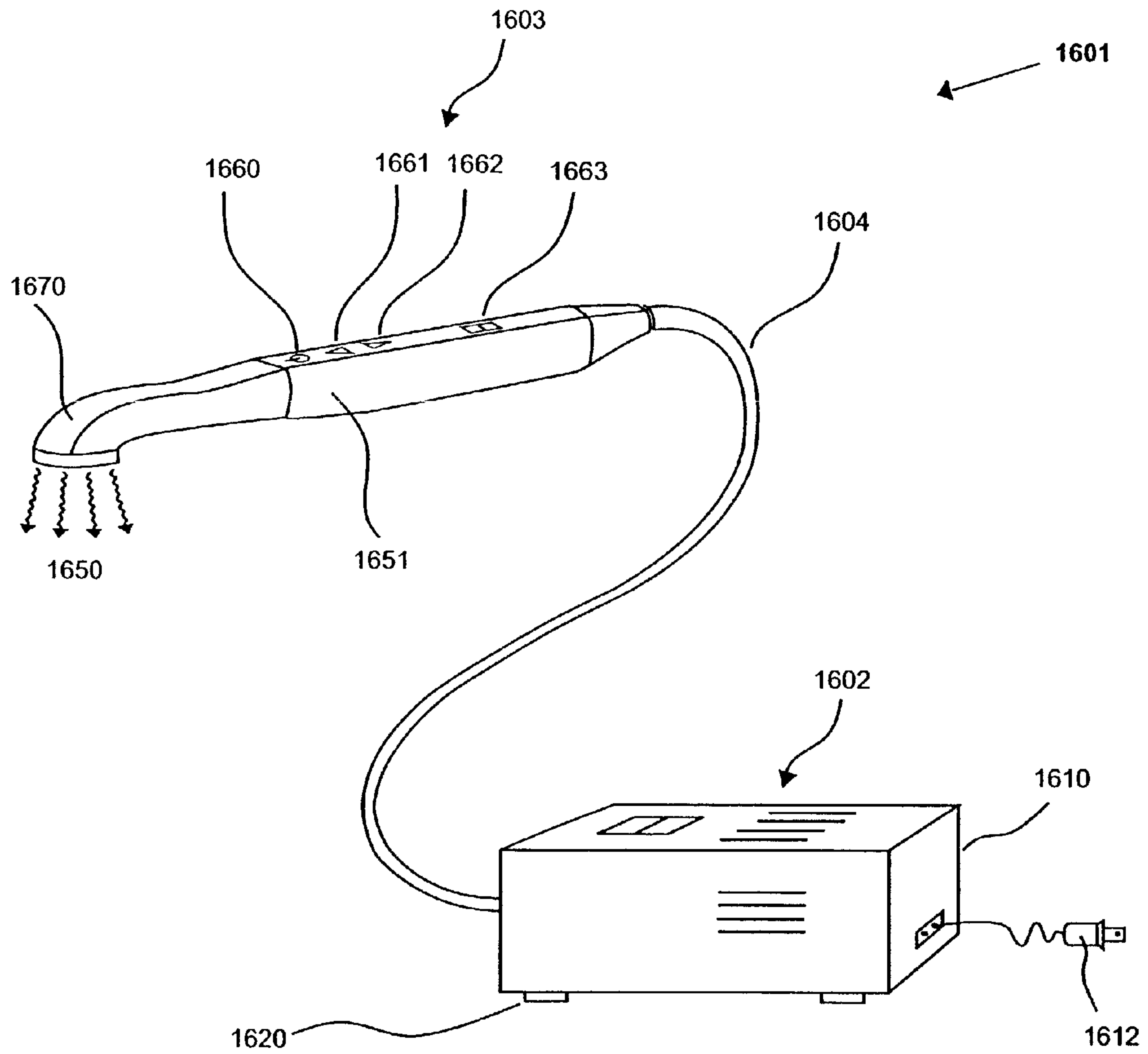

Fig. 16a

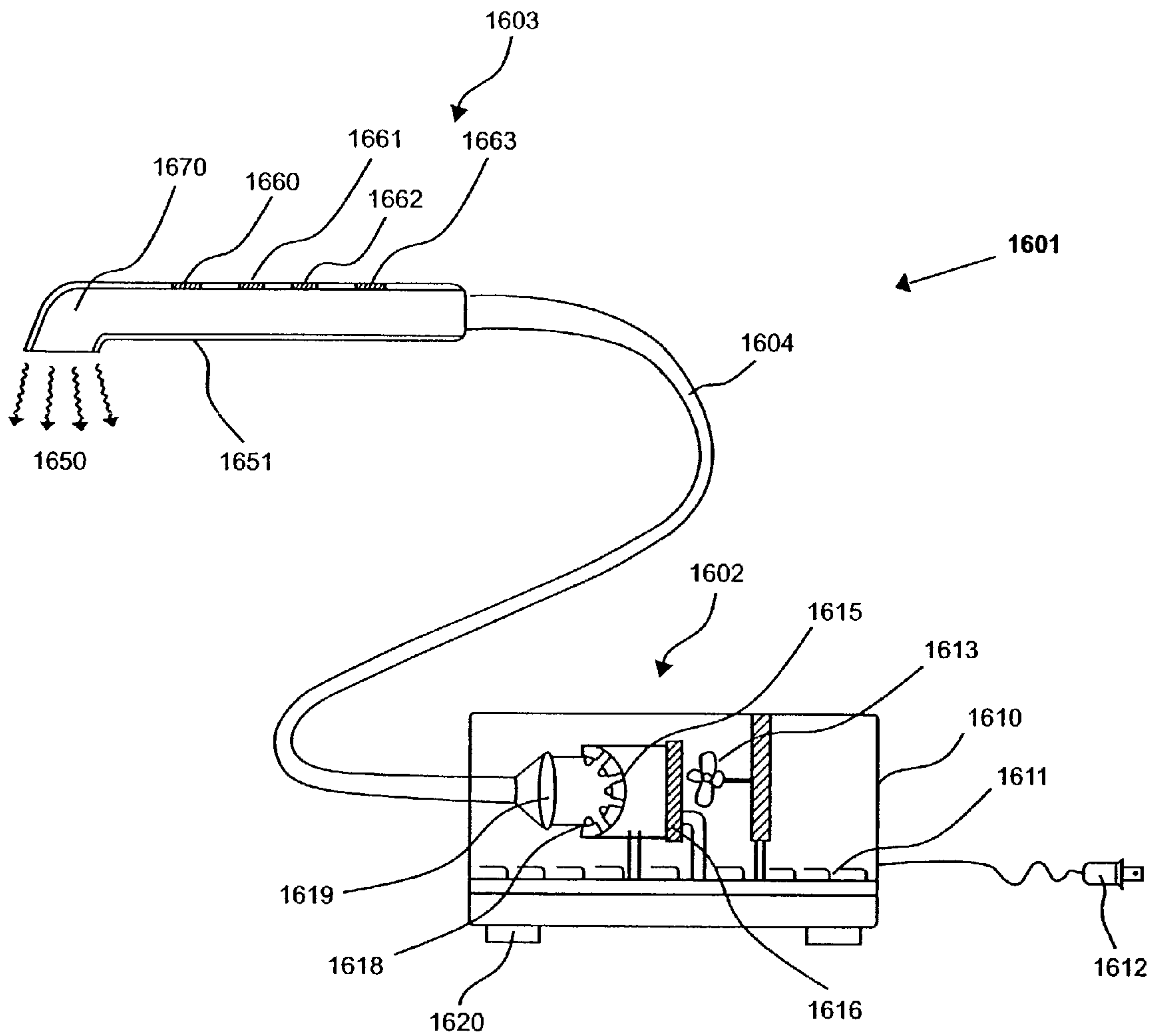

Fig. 16b



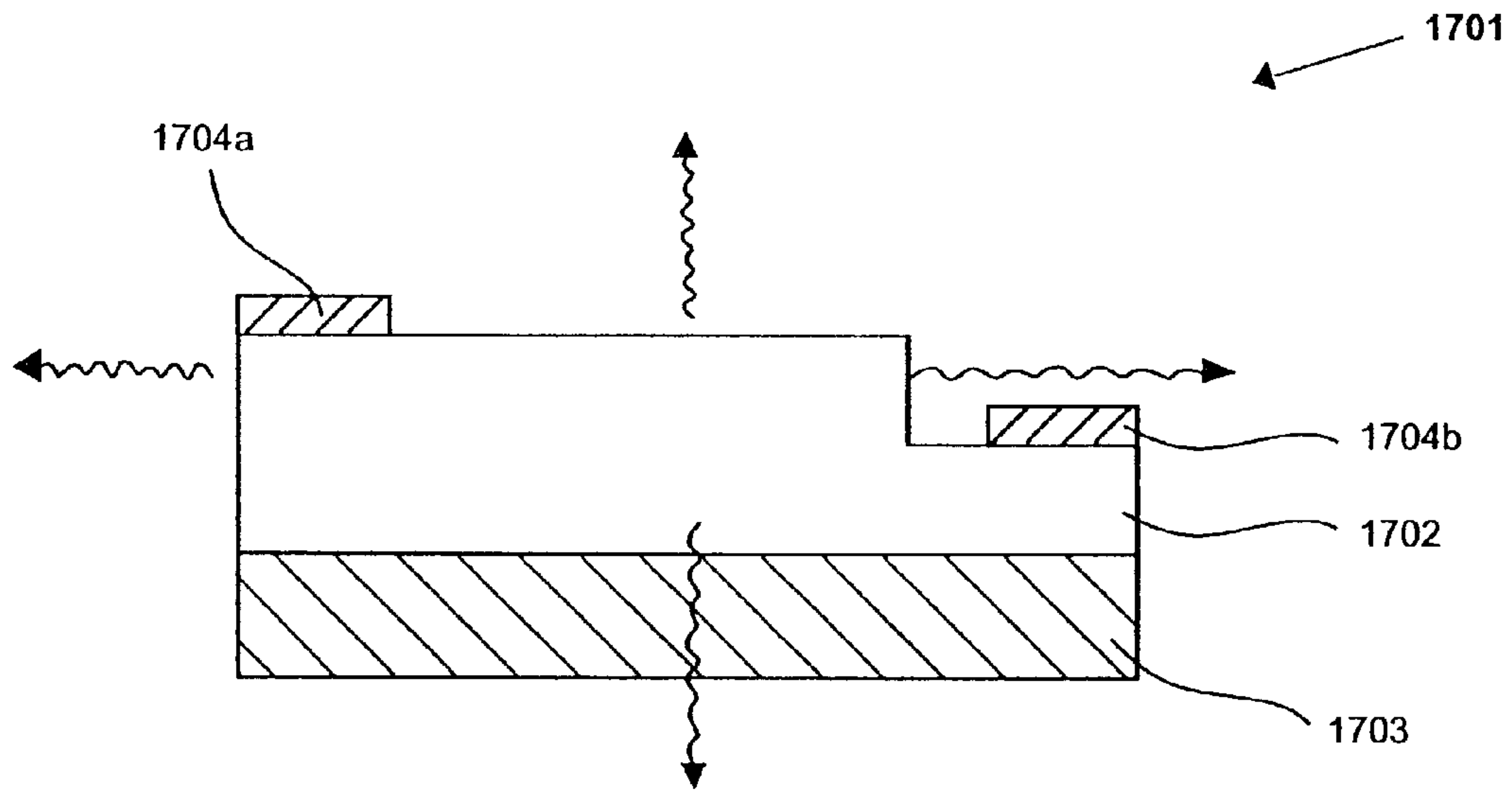

Fig. 17a

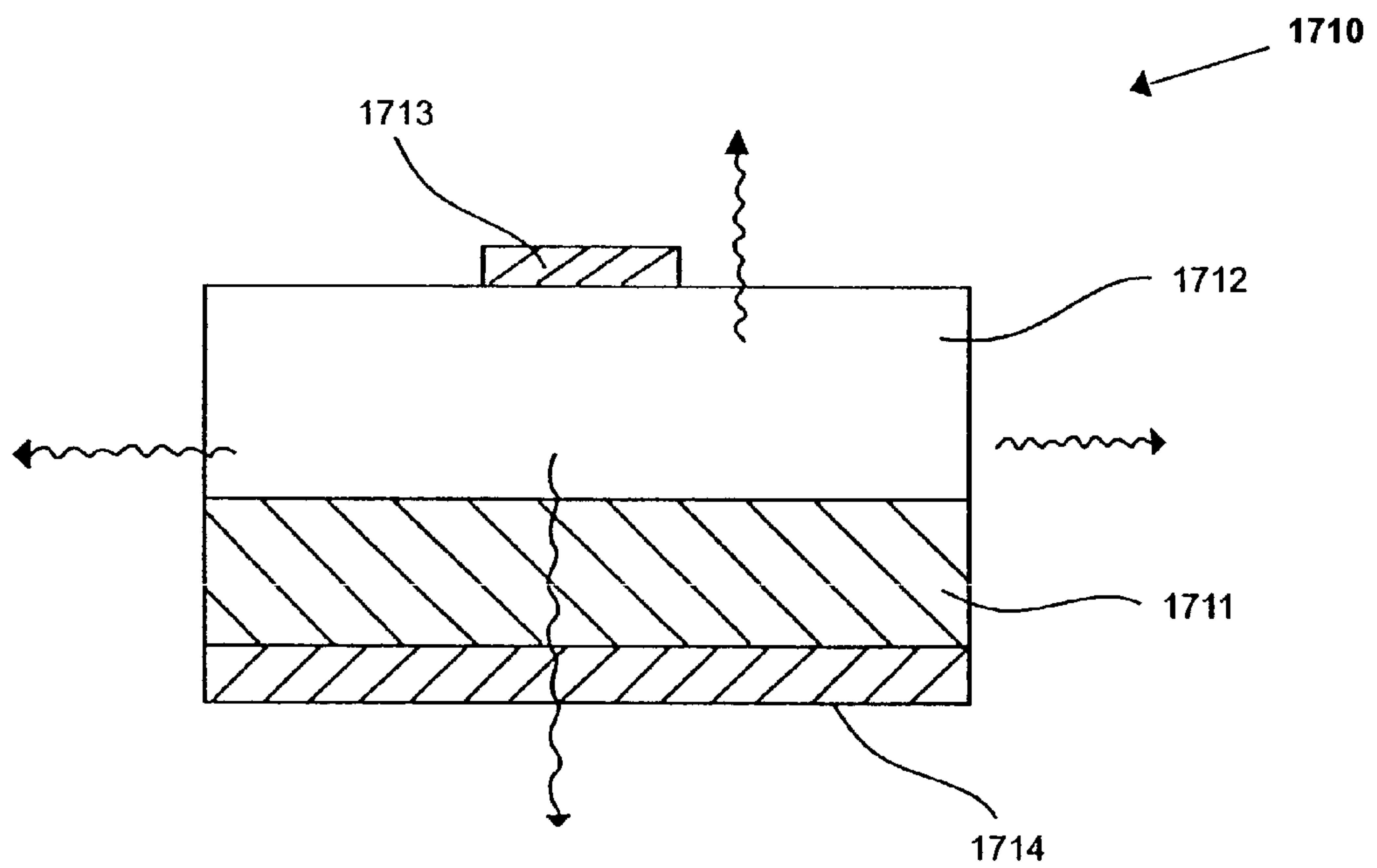

Fig. 17b

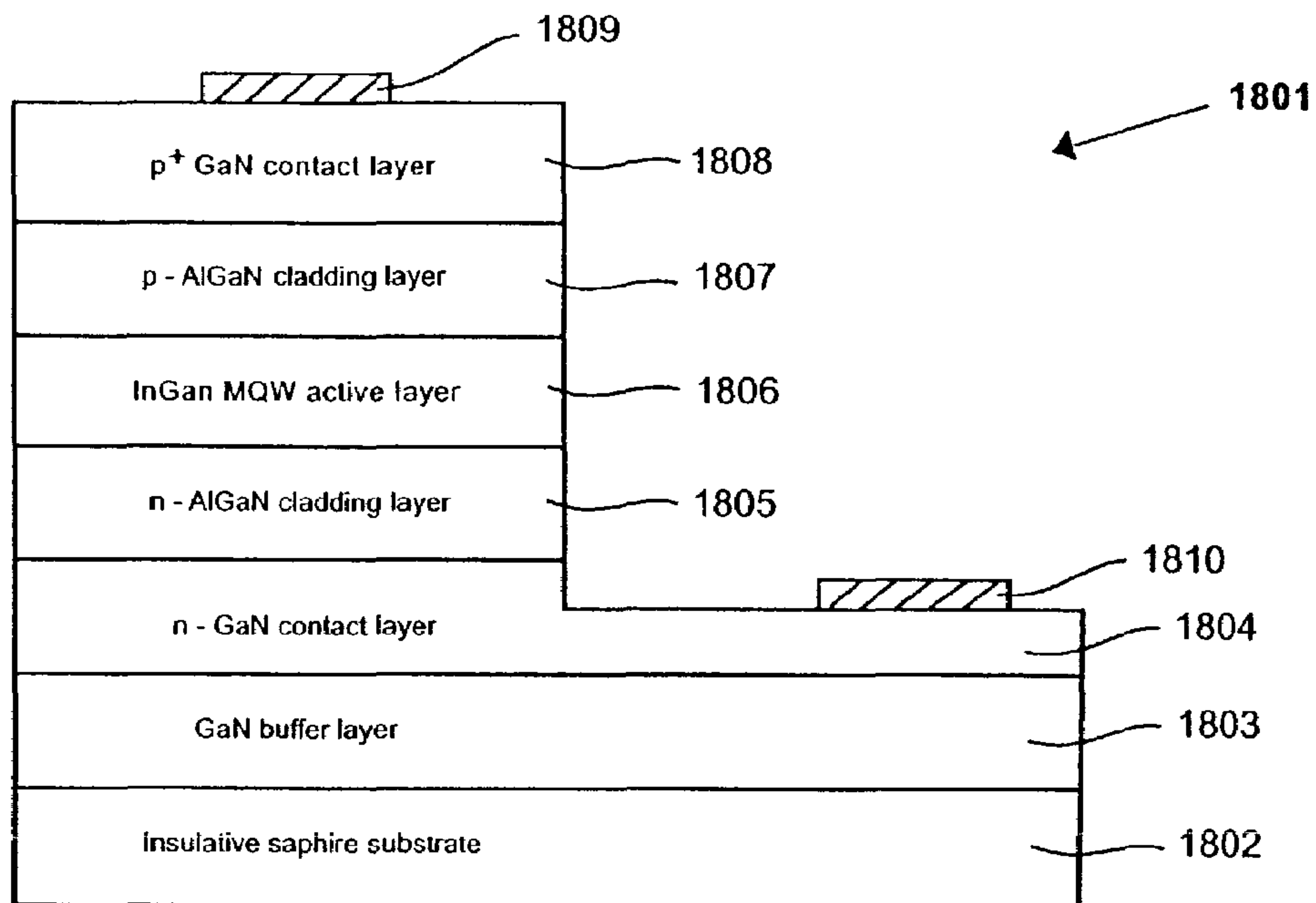

Fig. 18a

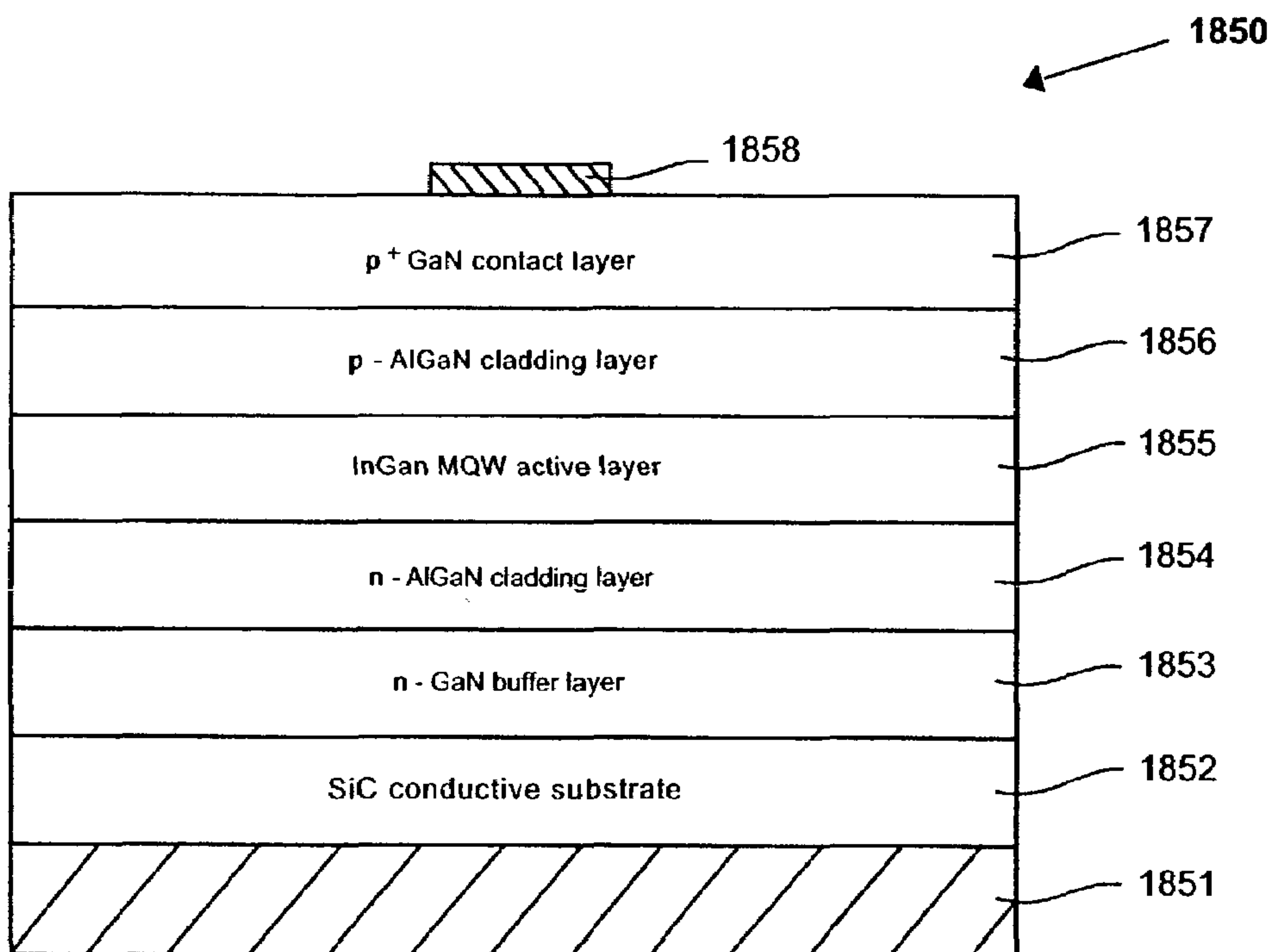

Fig. 18b

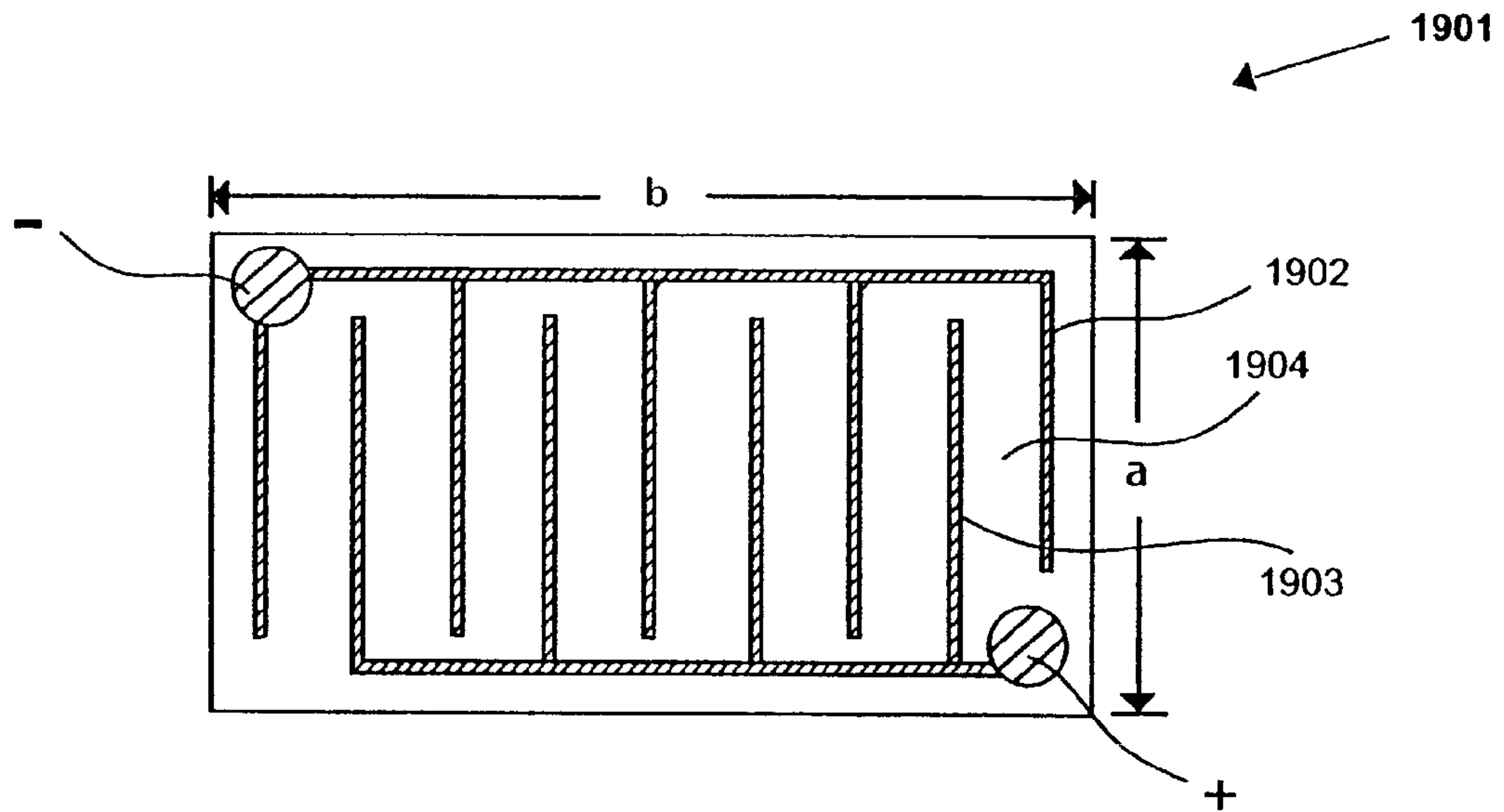

Fig. 19a

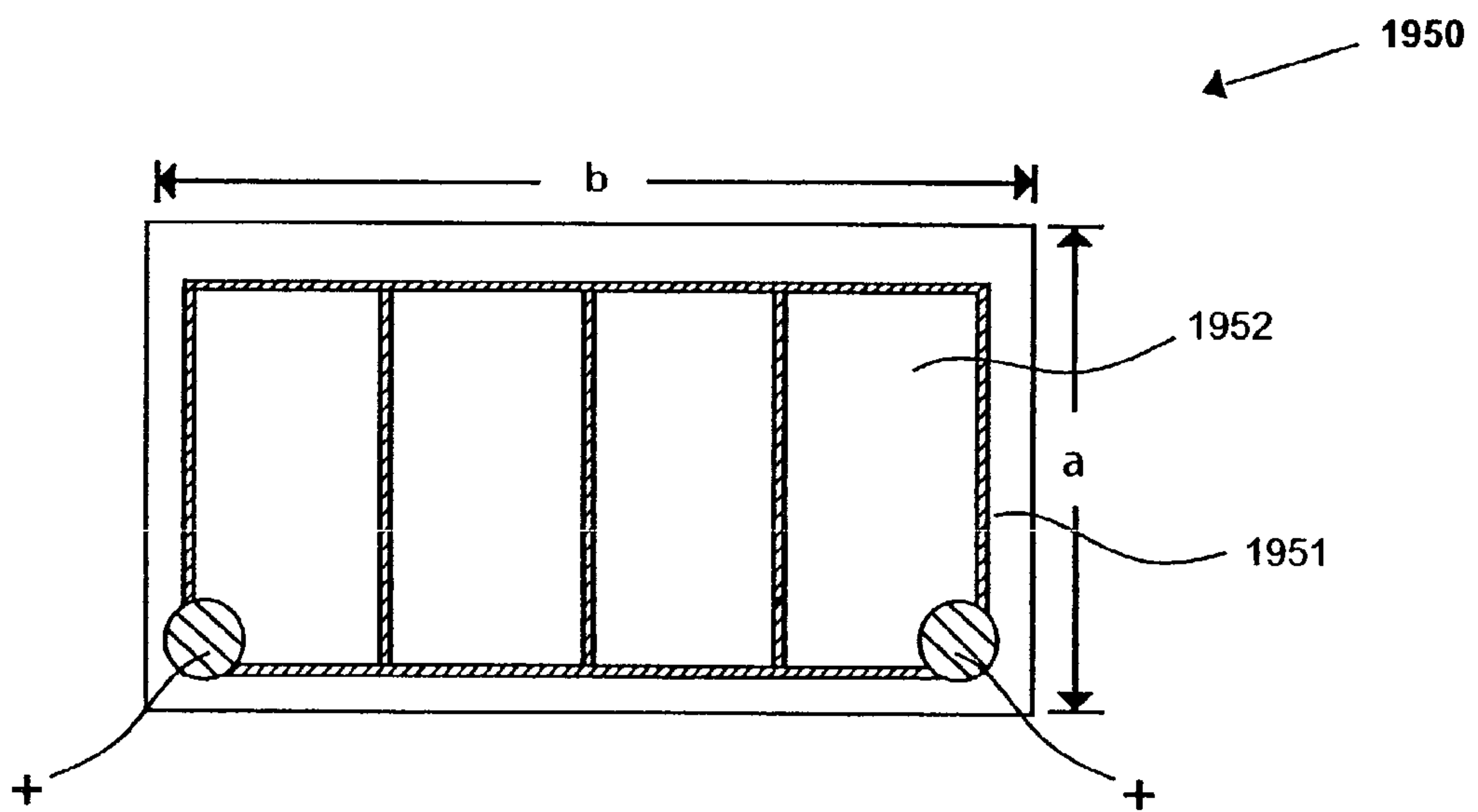

Fig. 19b

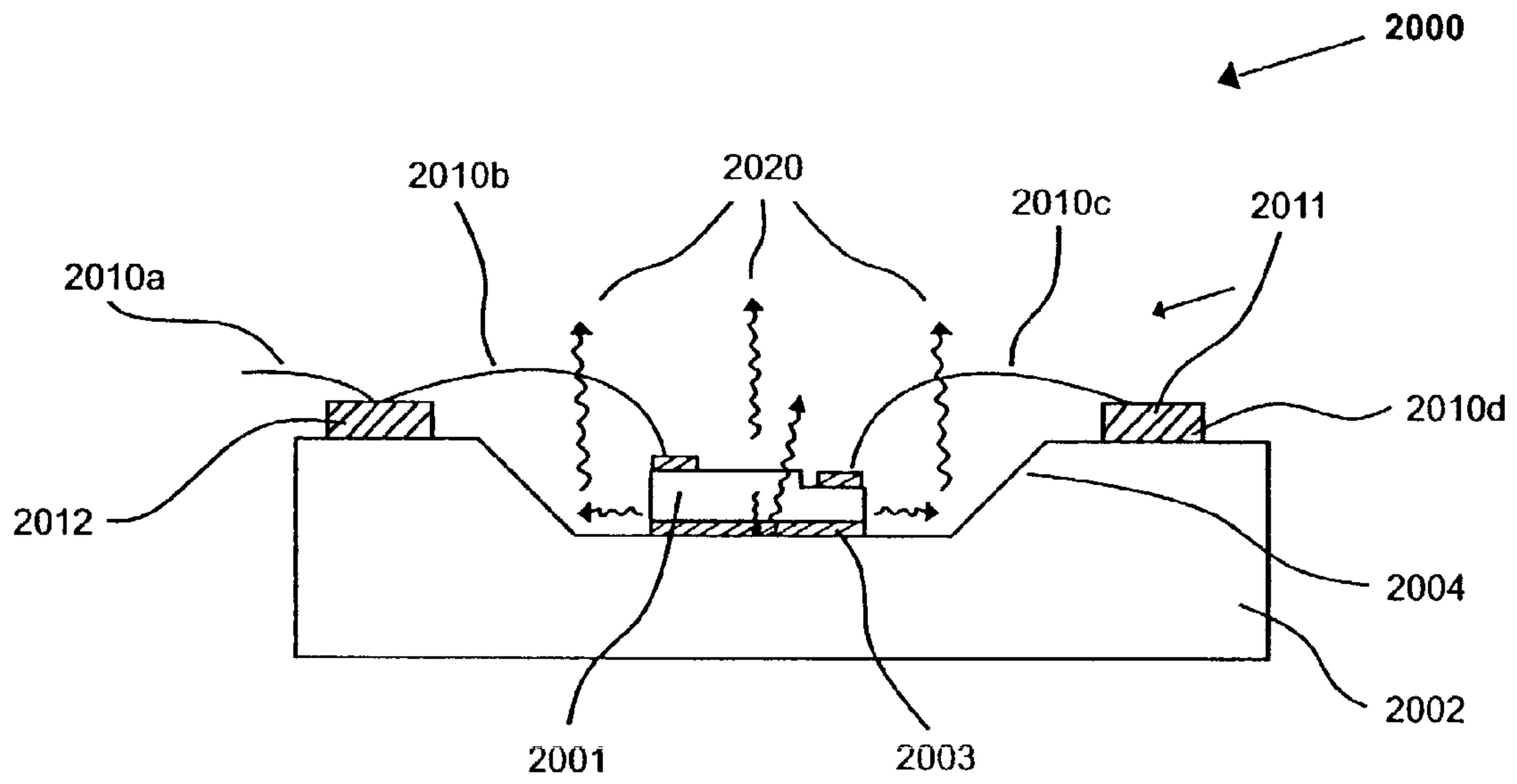

Fig. 20a

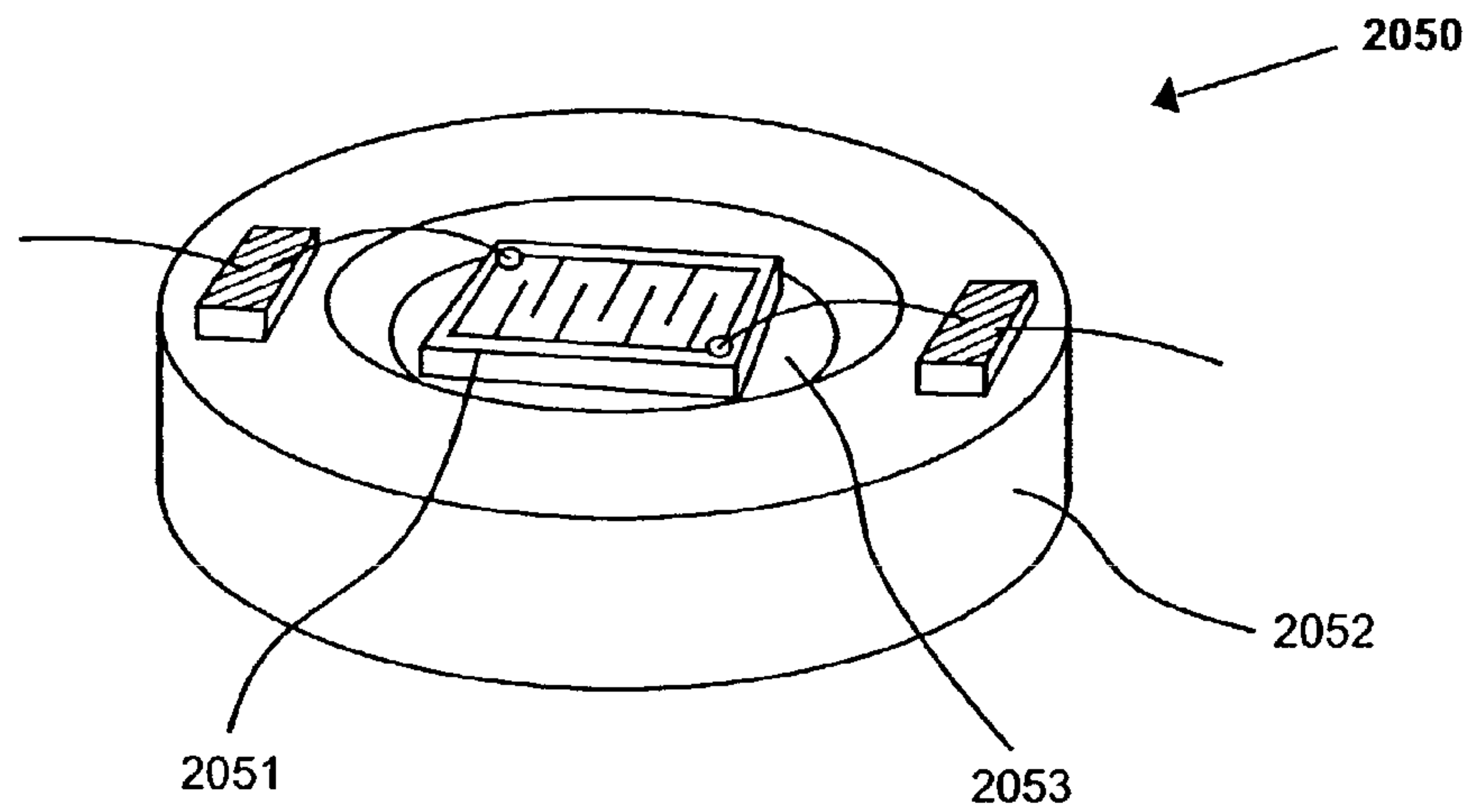

Fig. 20b



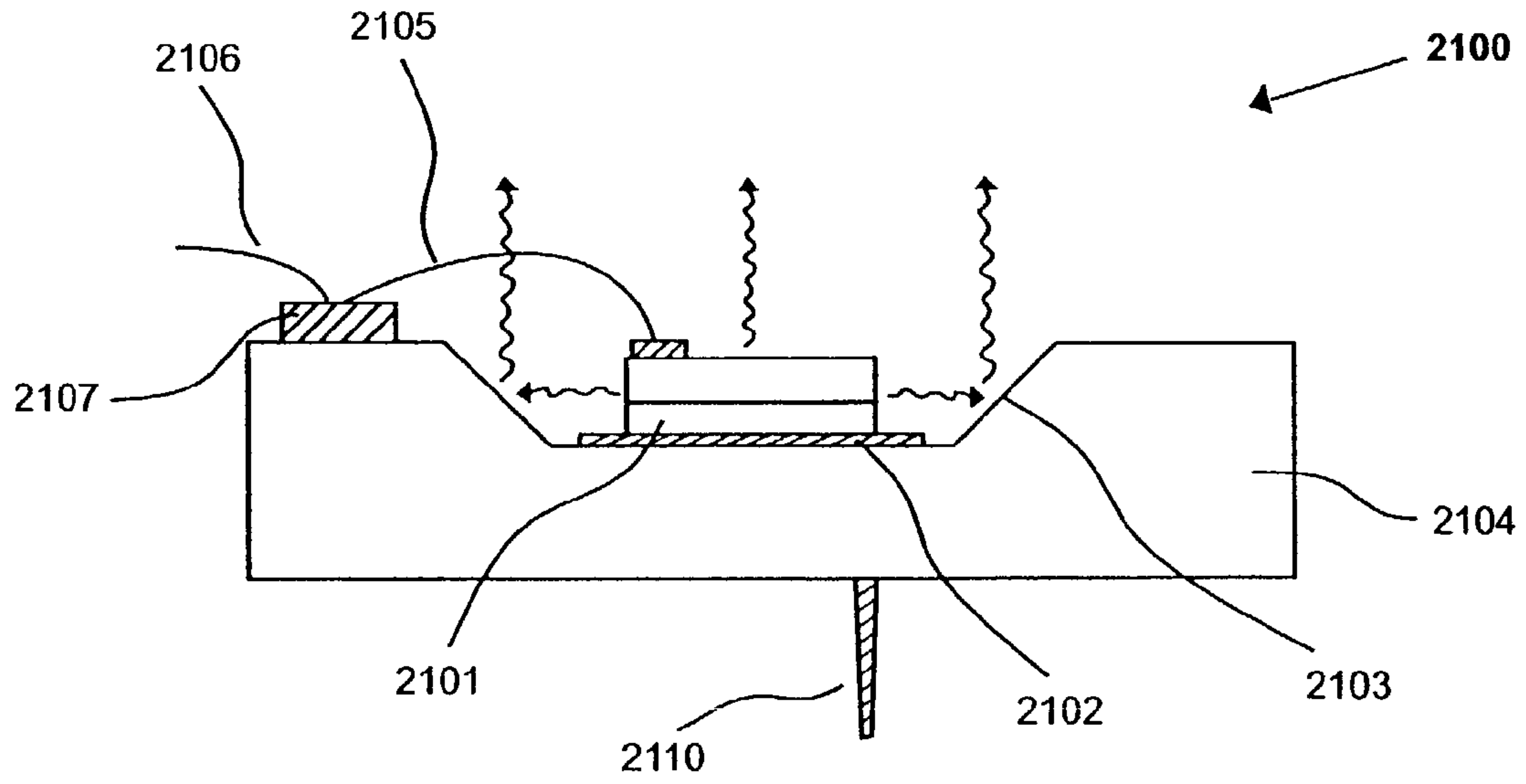

Fig. 21a

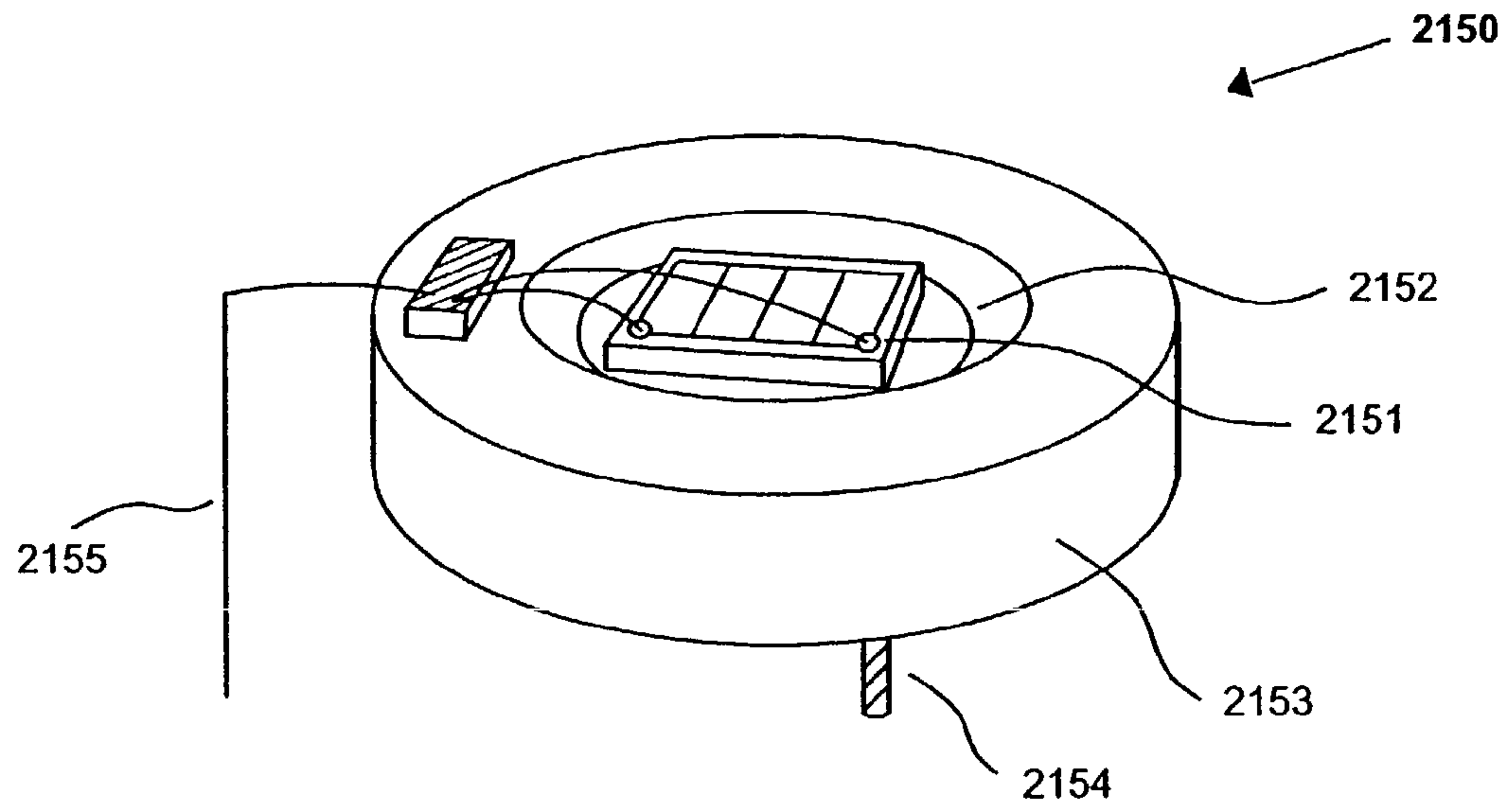

Fig. 21b

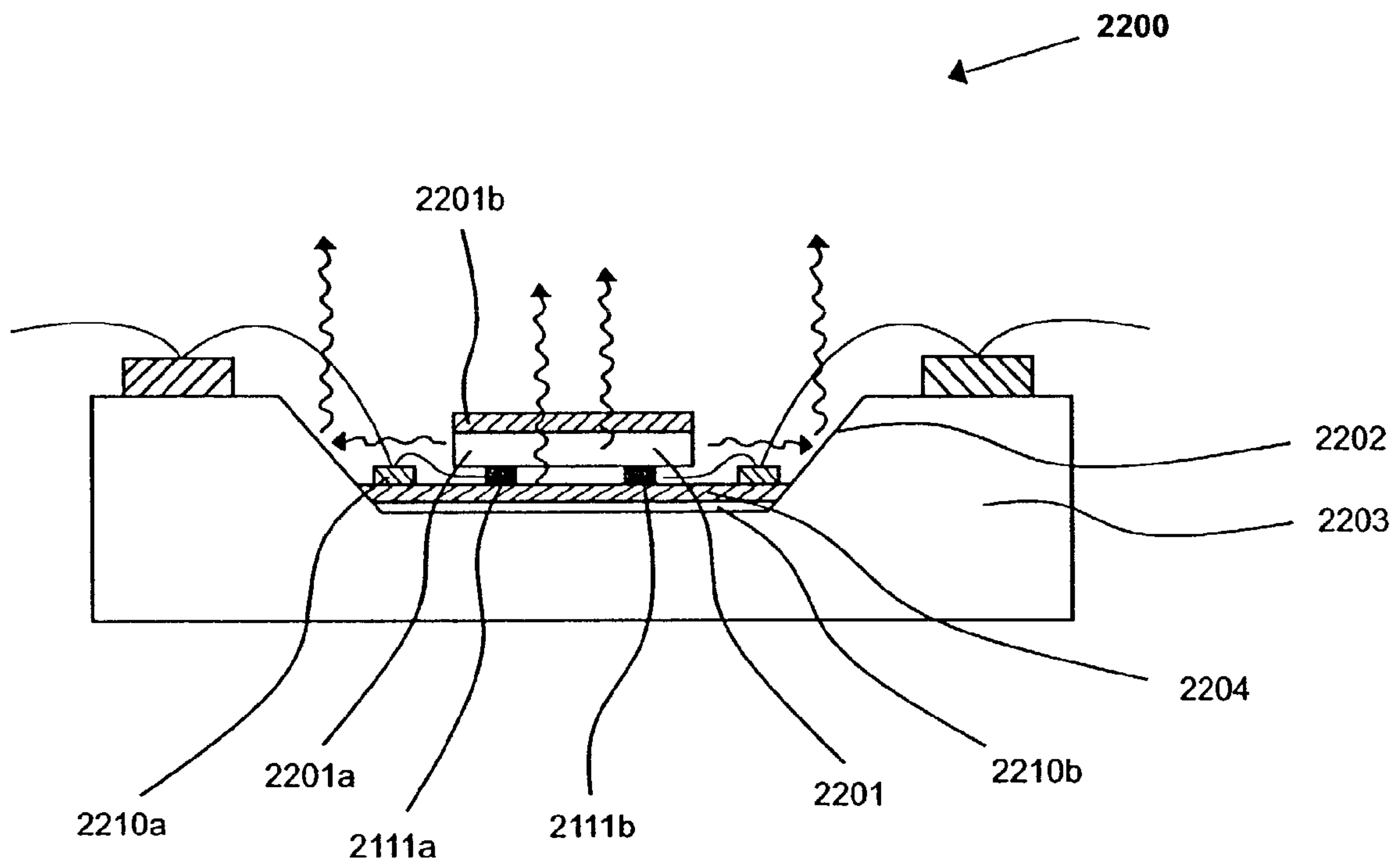

Fig. 22a

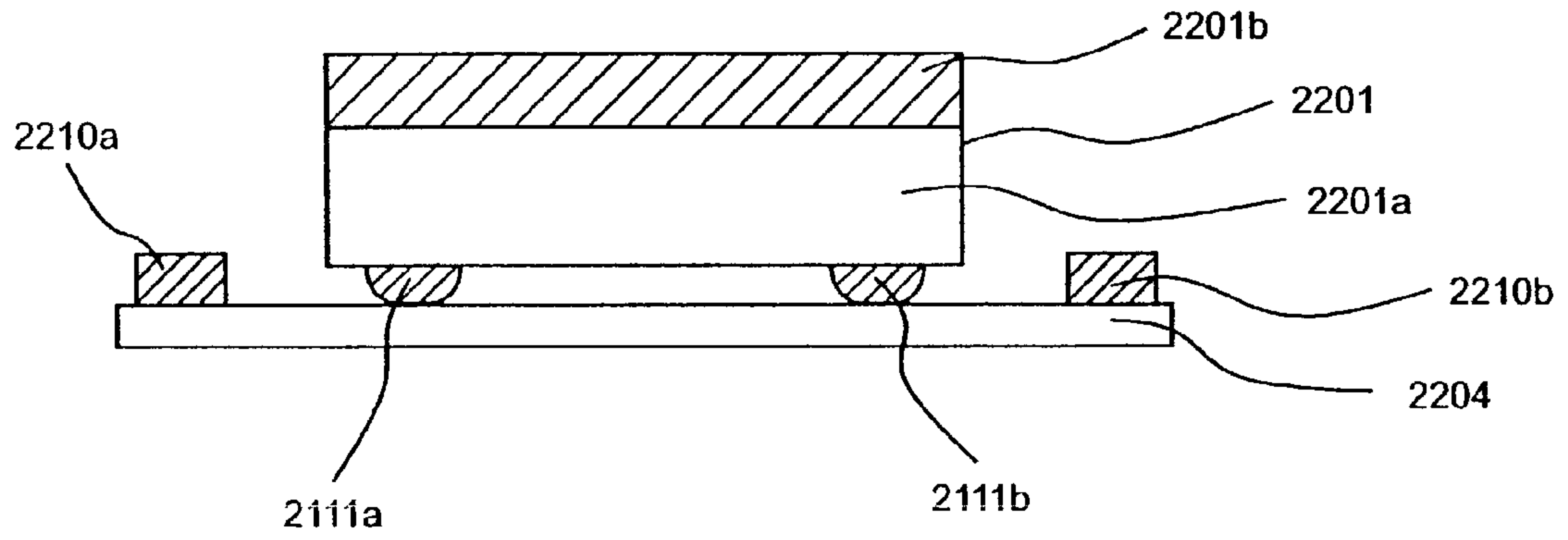

Fig. 22b

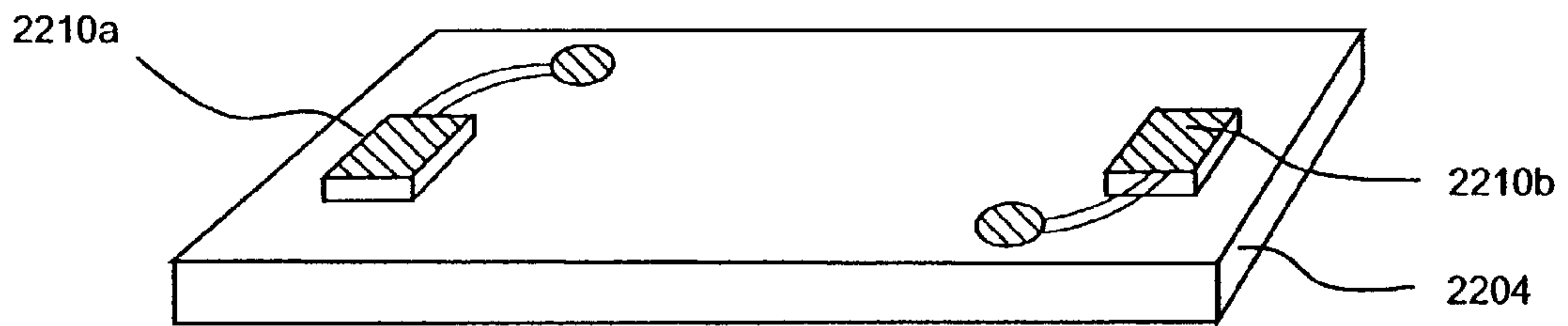

Fig. 22c

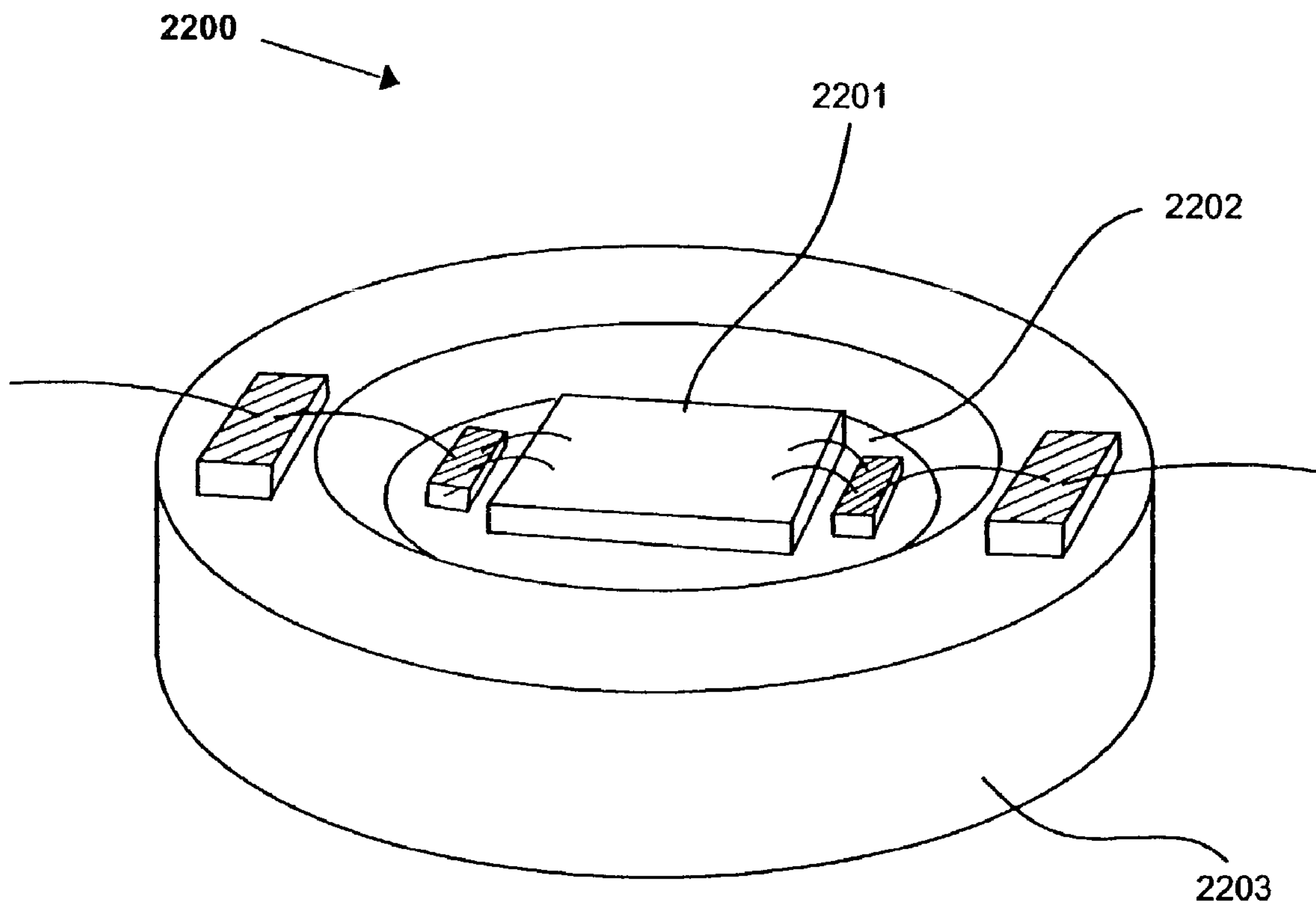

Fig. 22d

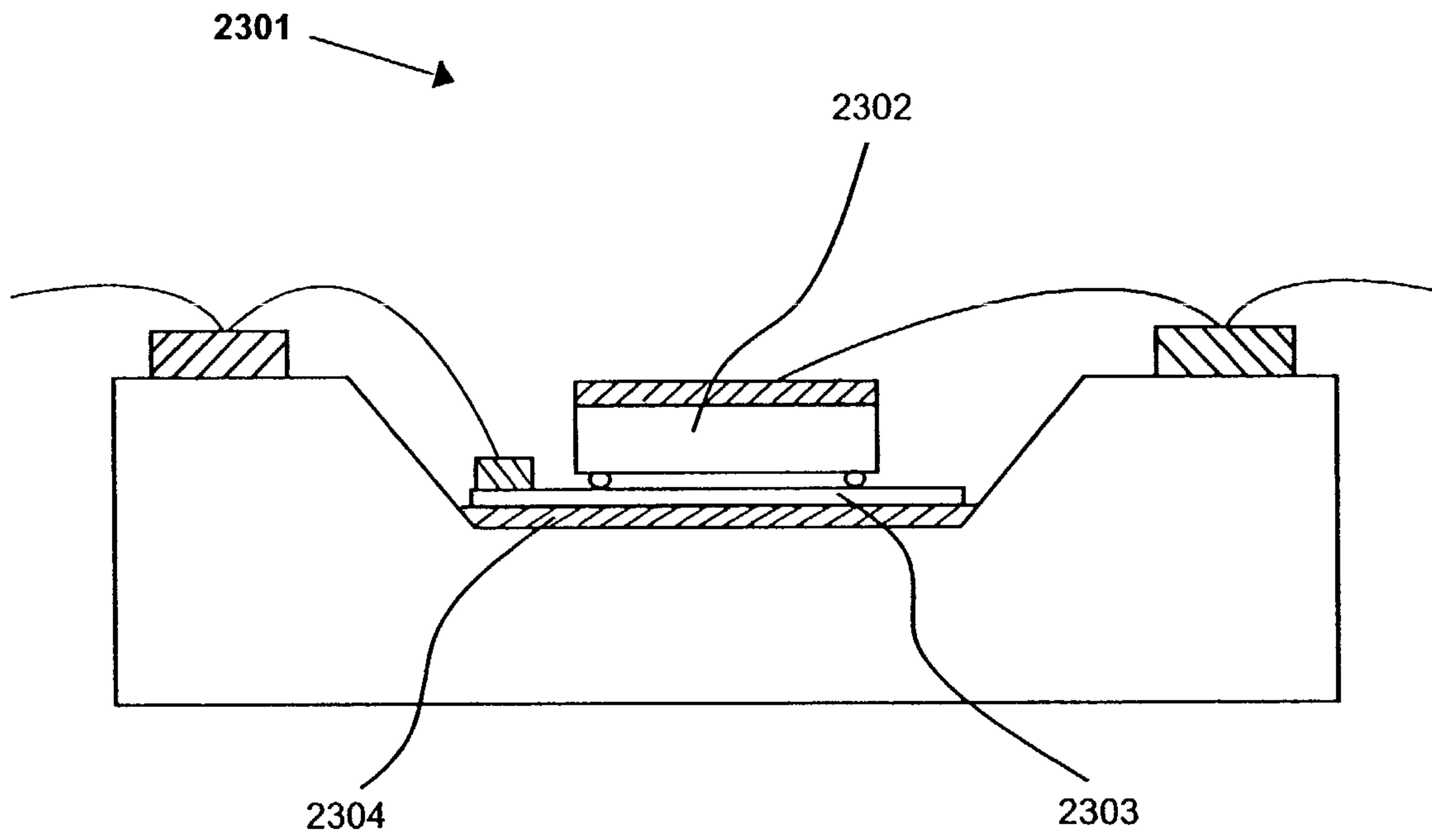

Fig. 23



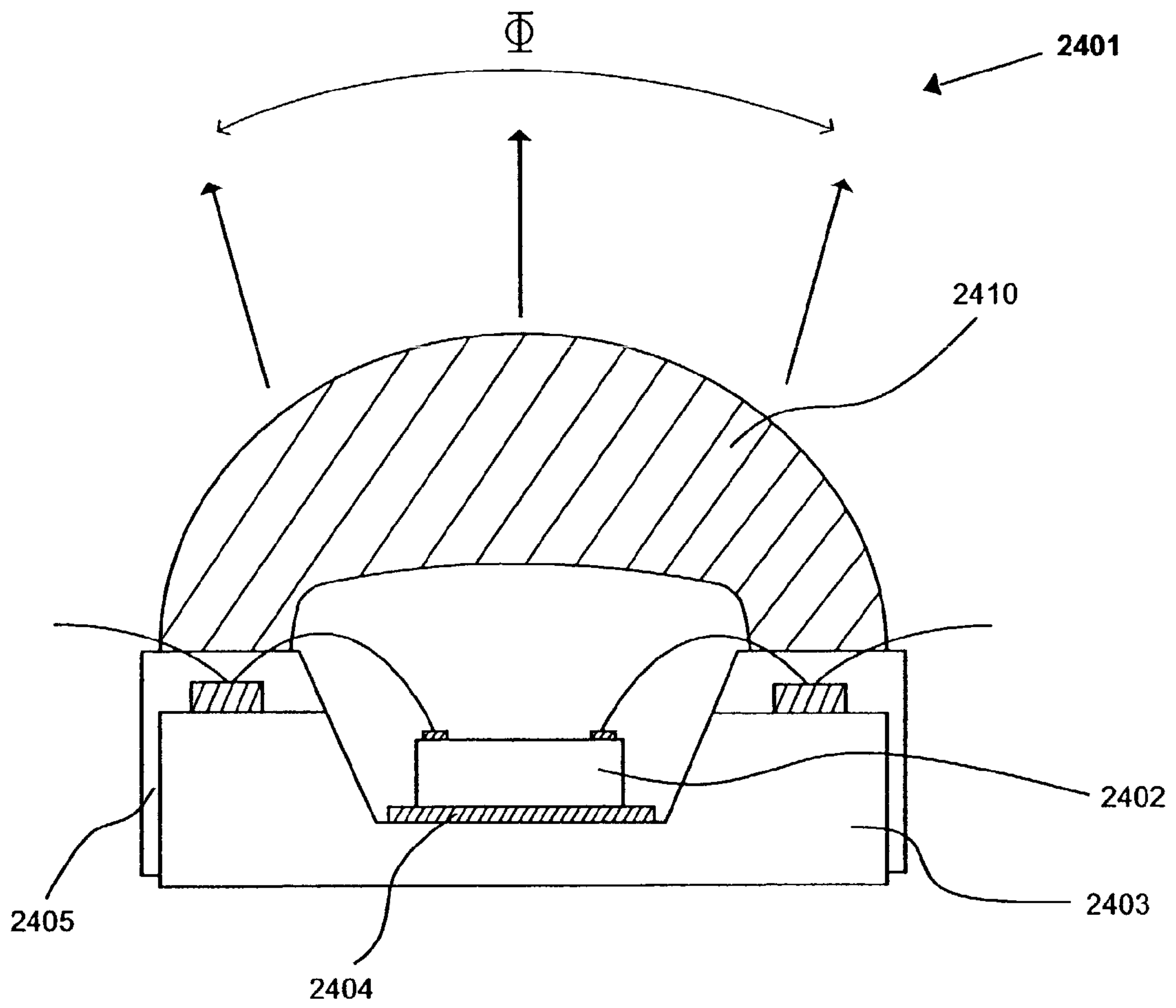

Fig. 24a

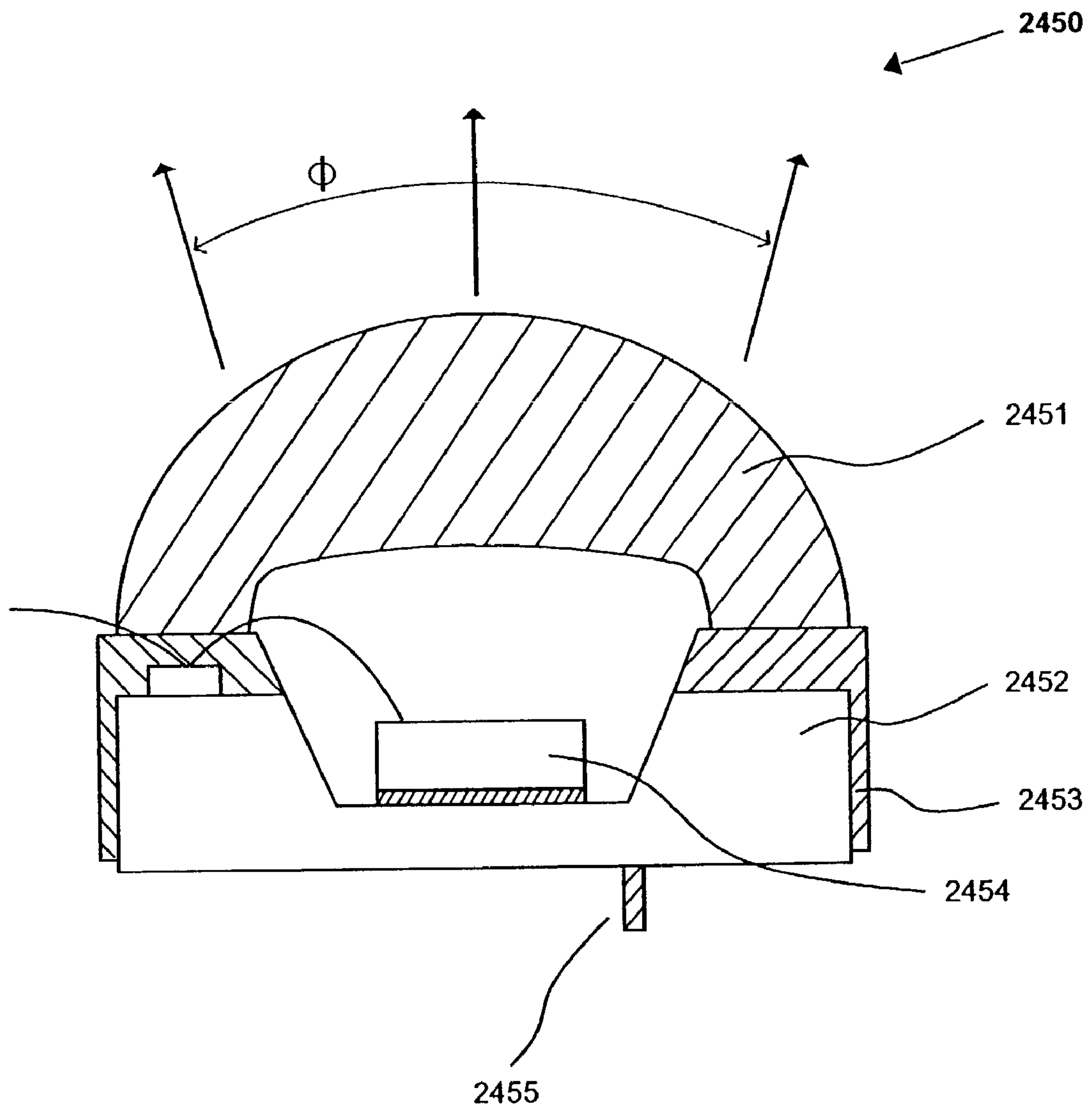

Fig. 24b

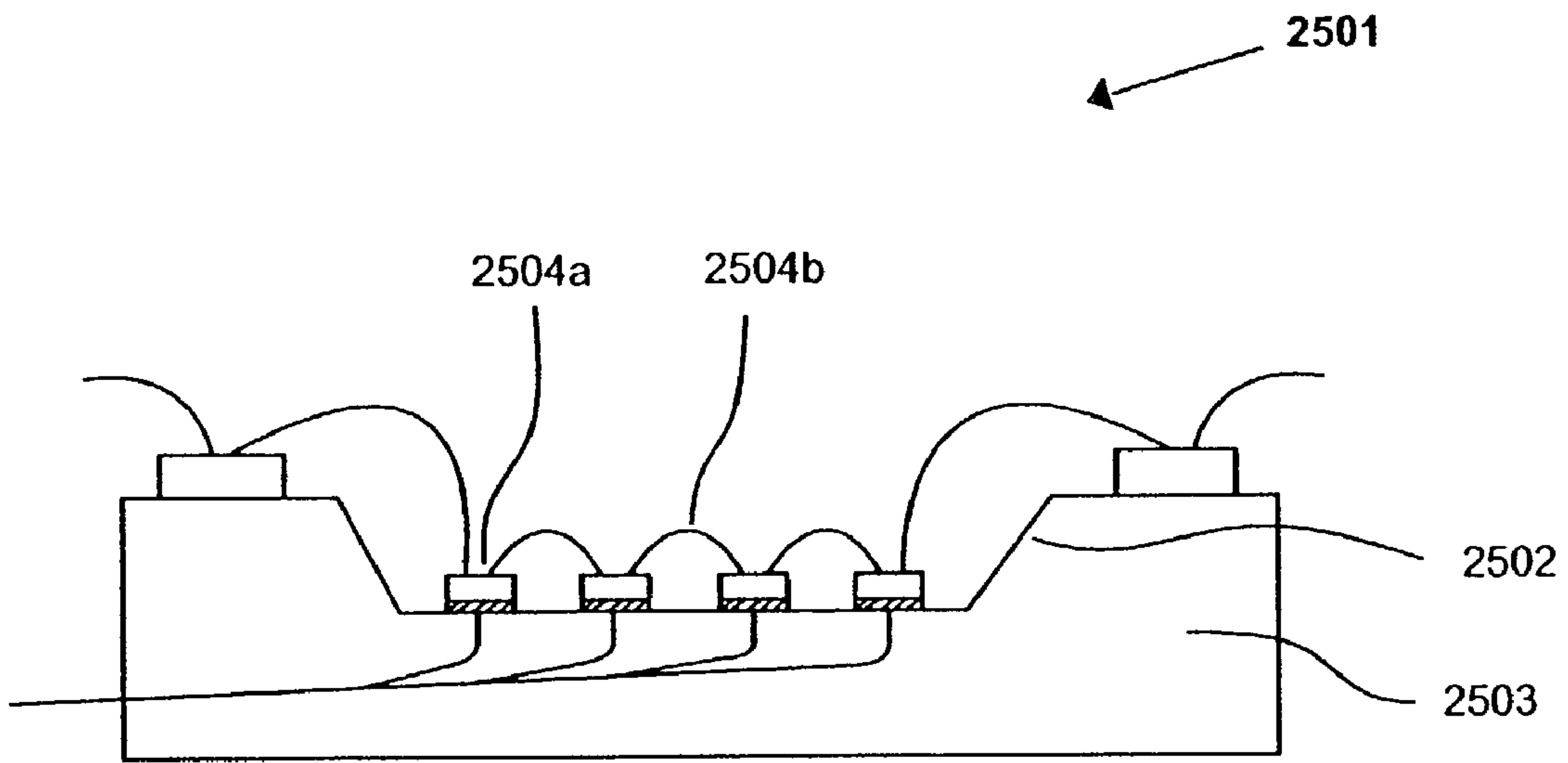

Fig. 25a

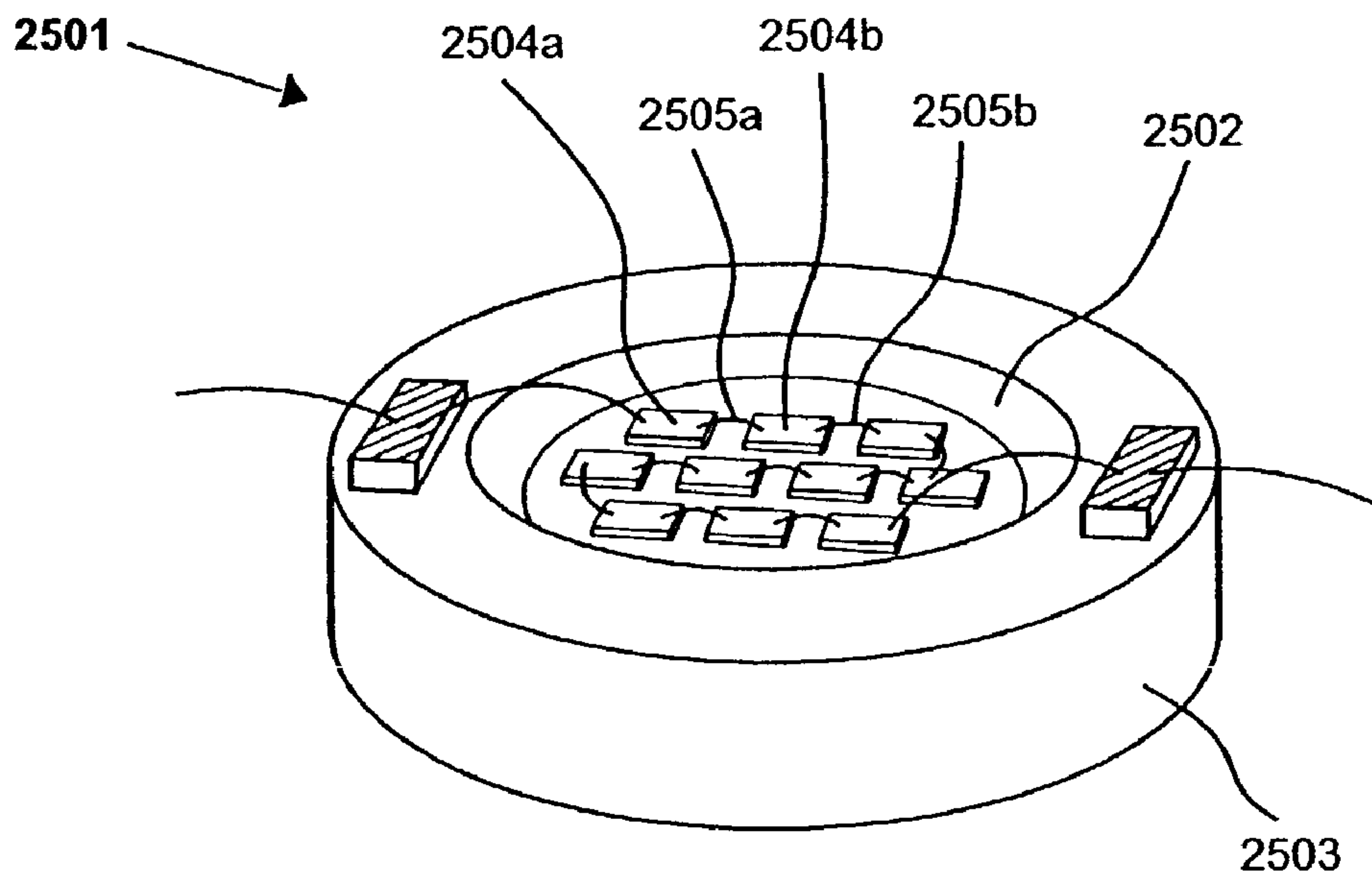

Fig. 25b

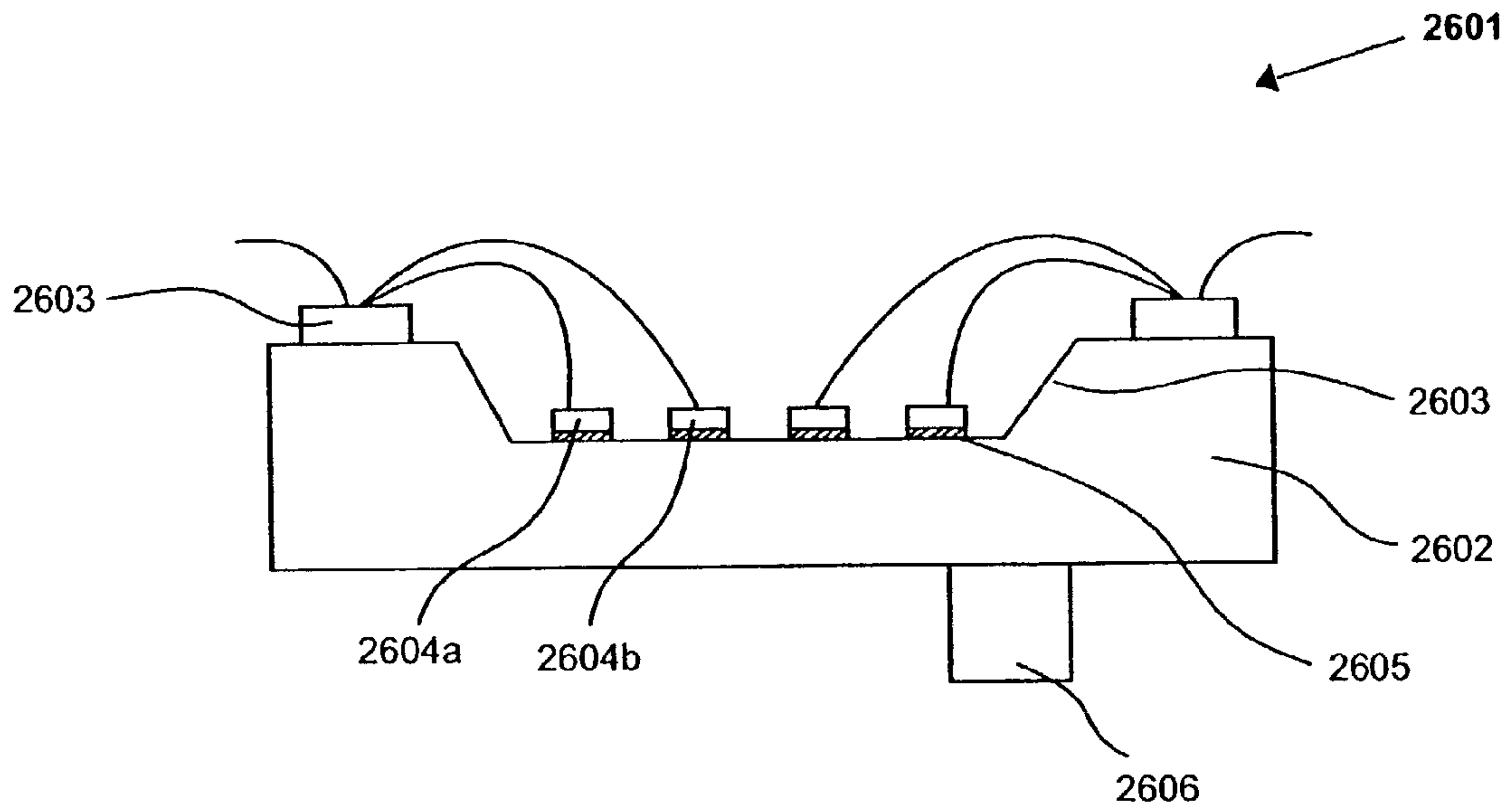

Fig. 26a

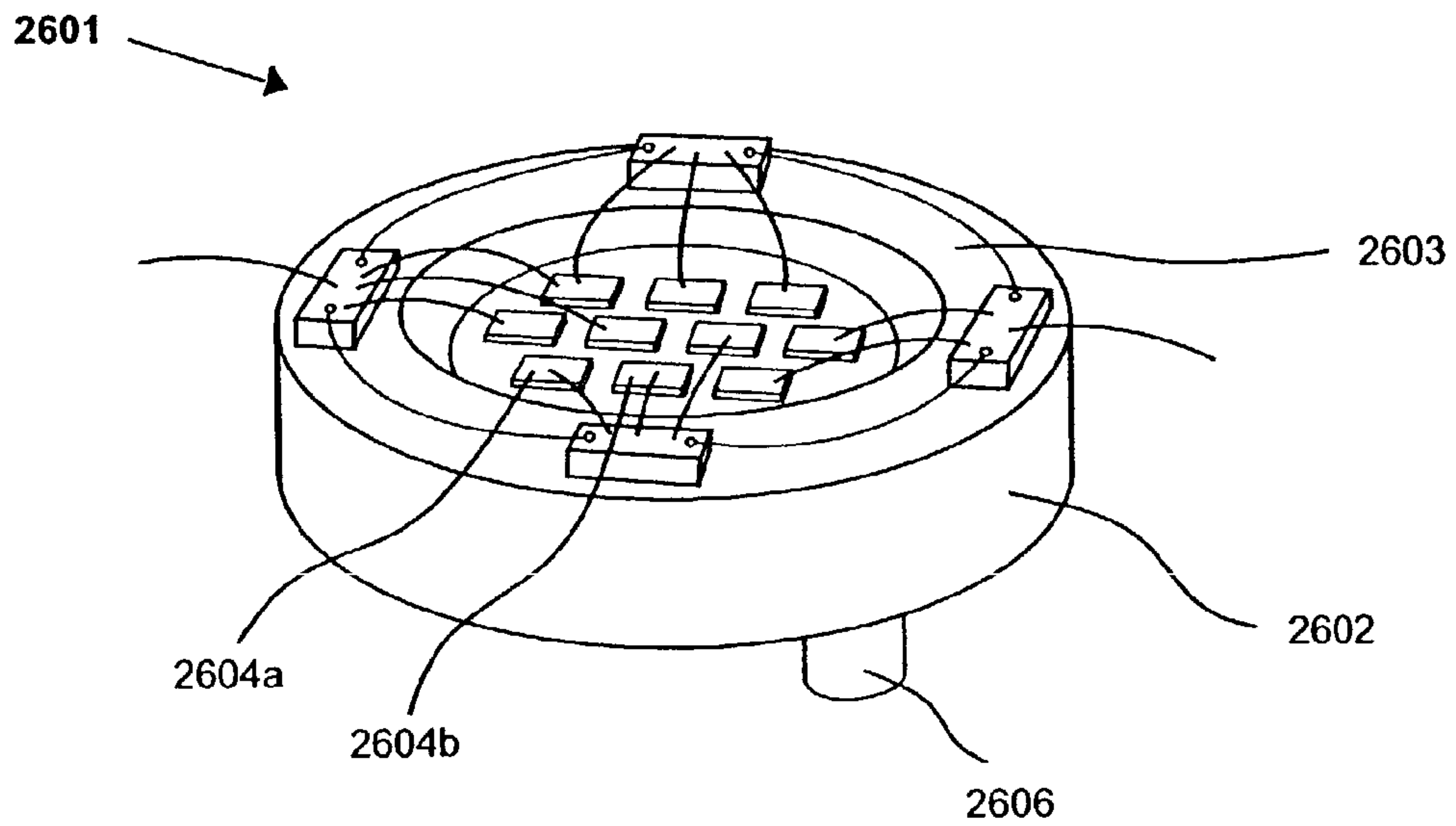

Fig. 26b

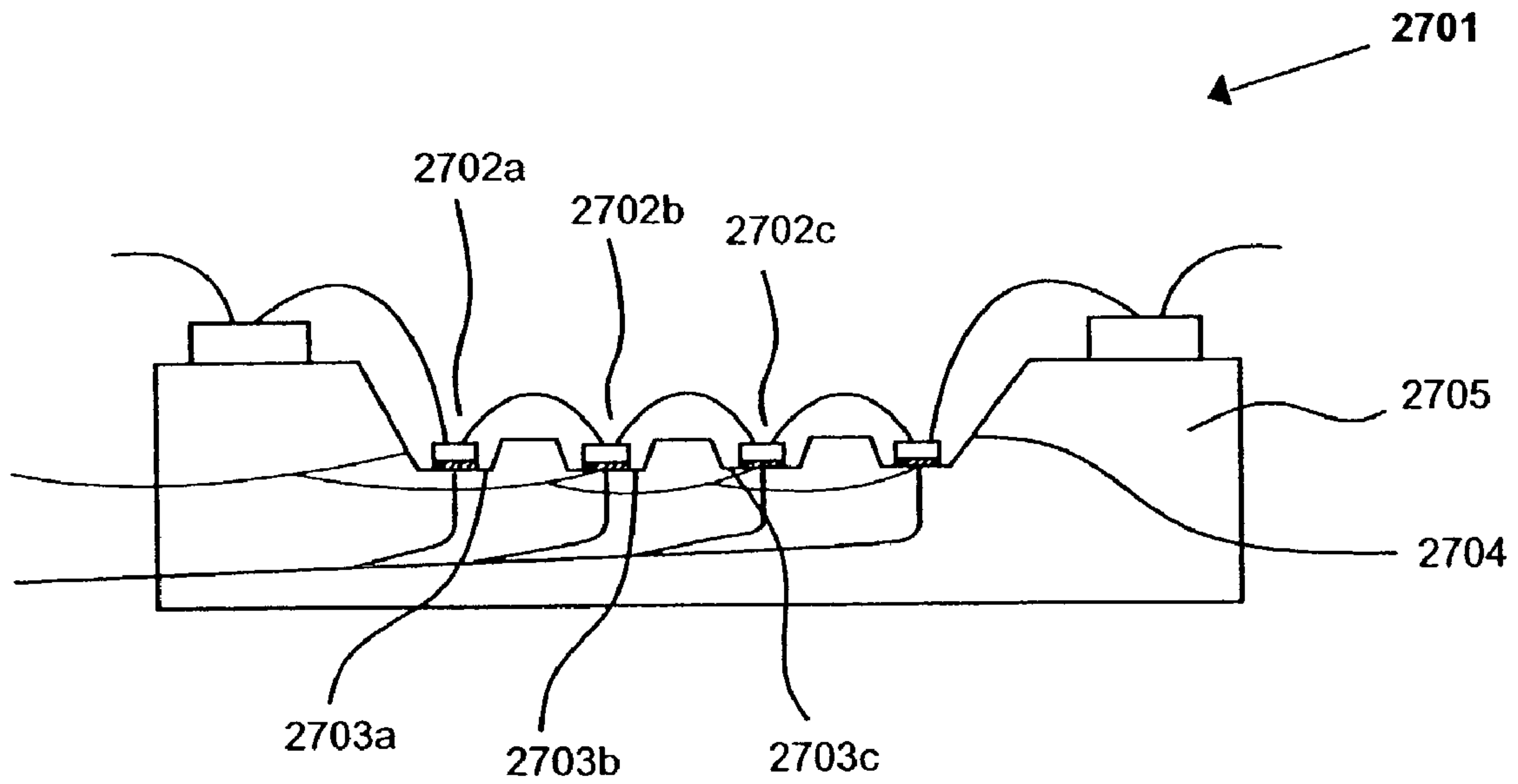

Fig. 27a

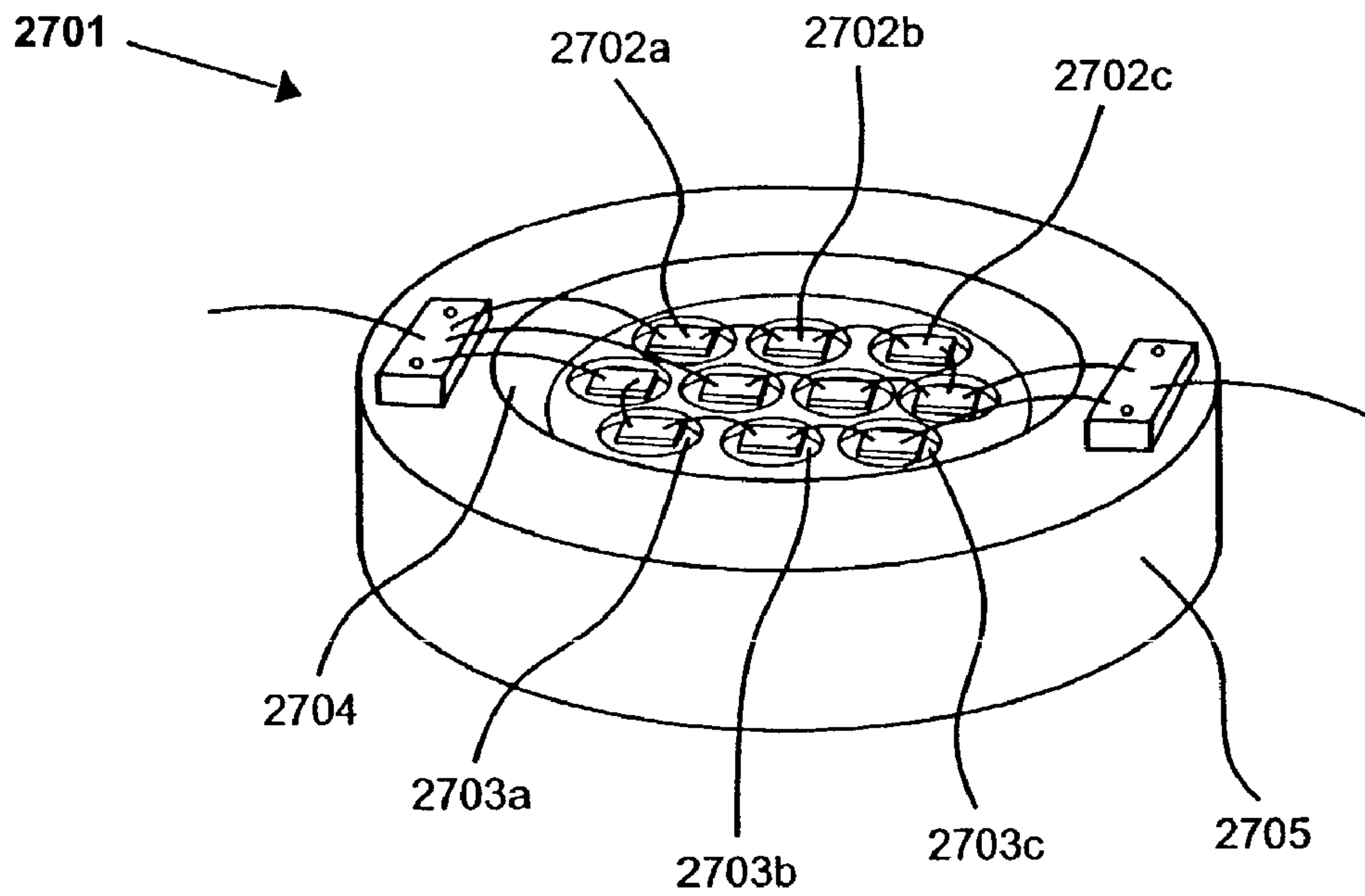

Fig. 27b

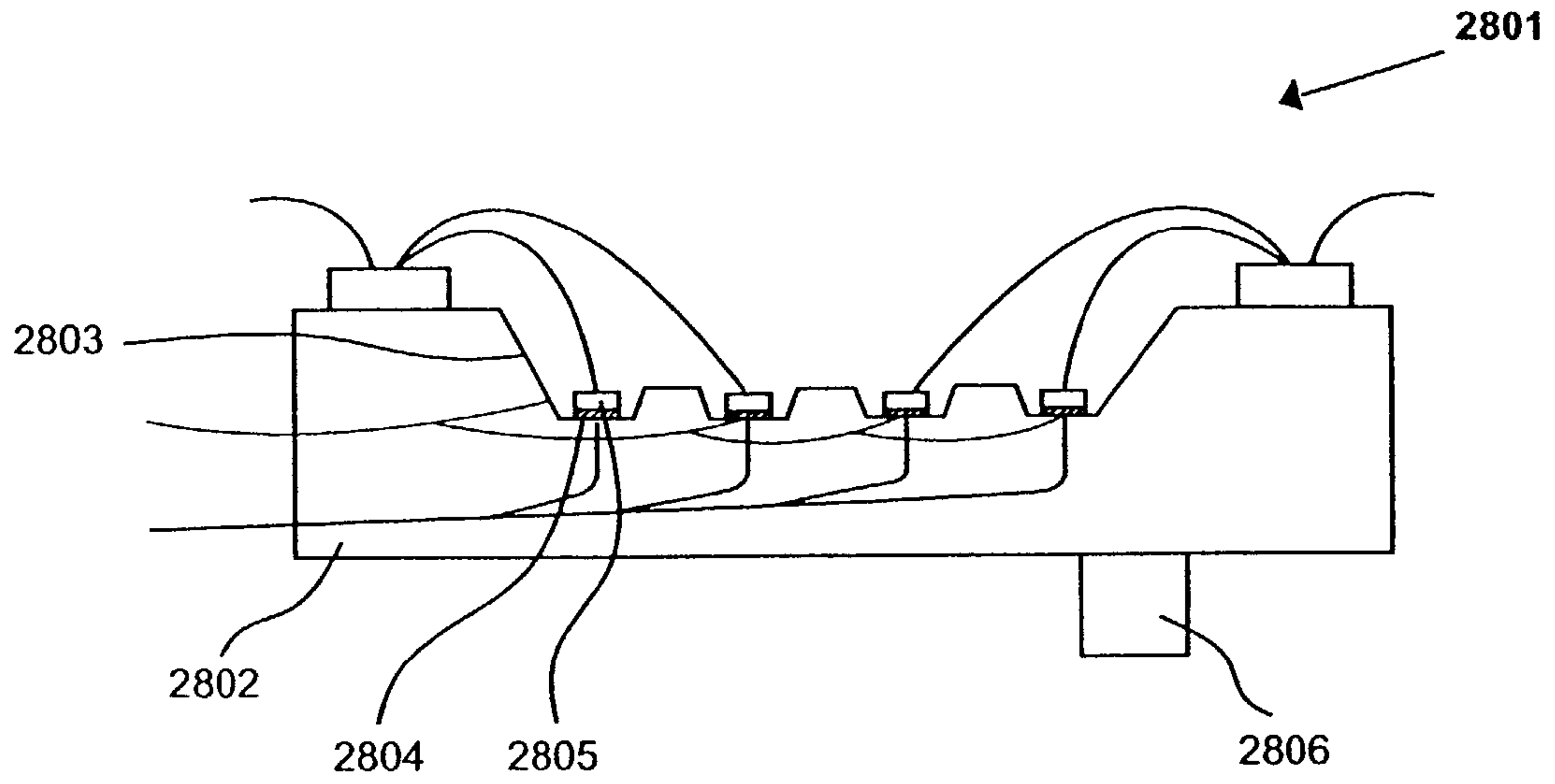

Fig. 28a

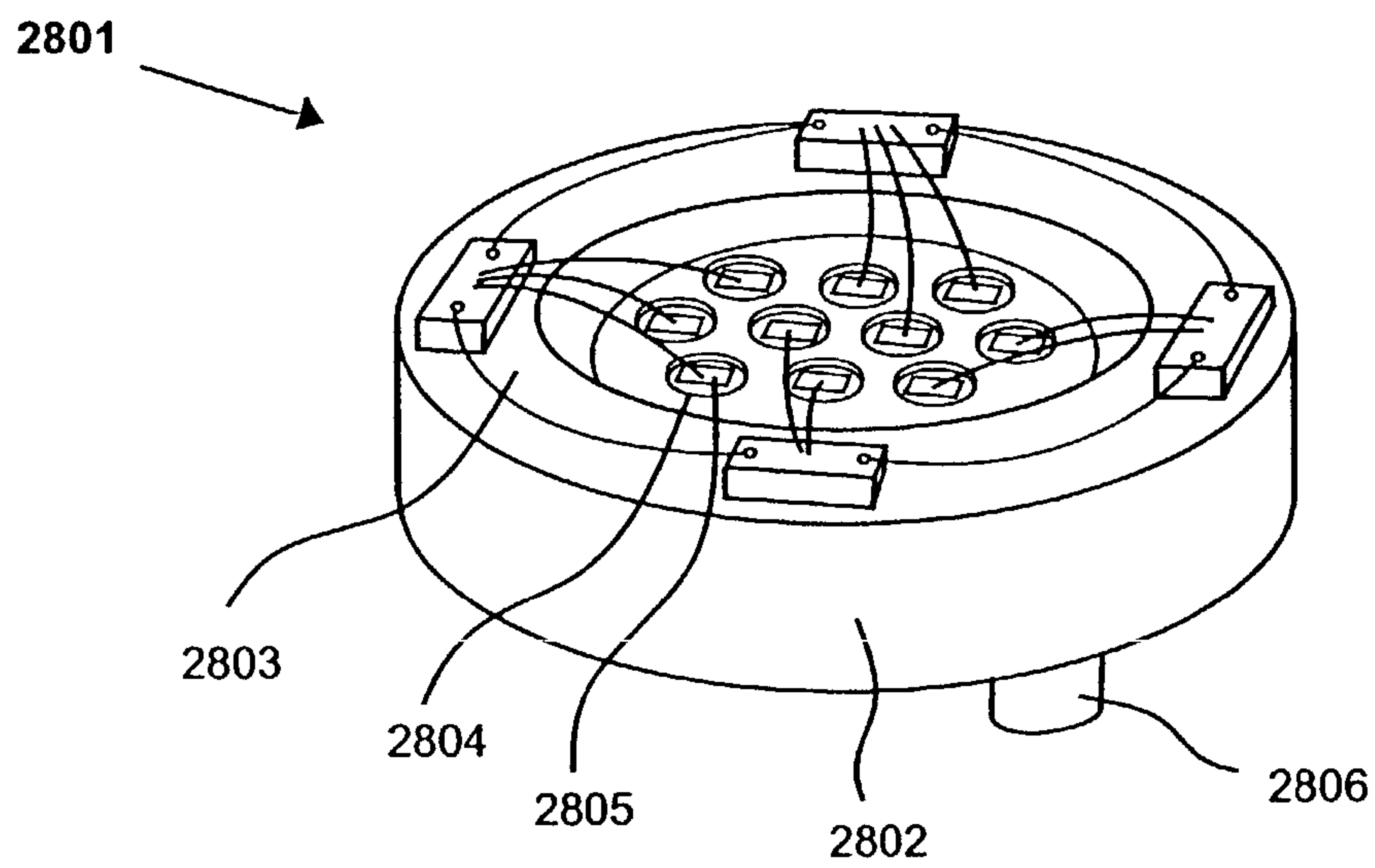

Fig. 28b



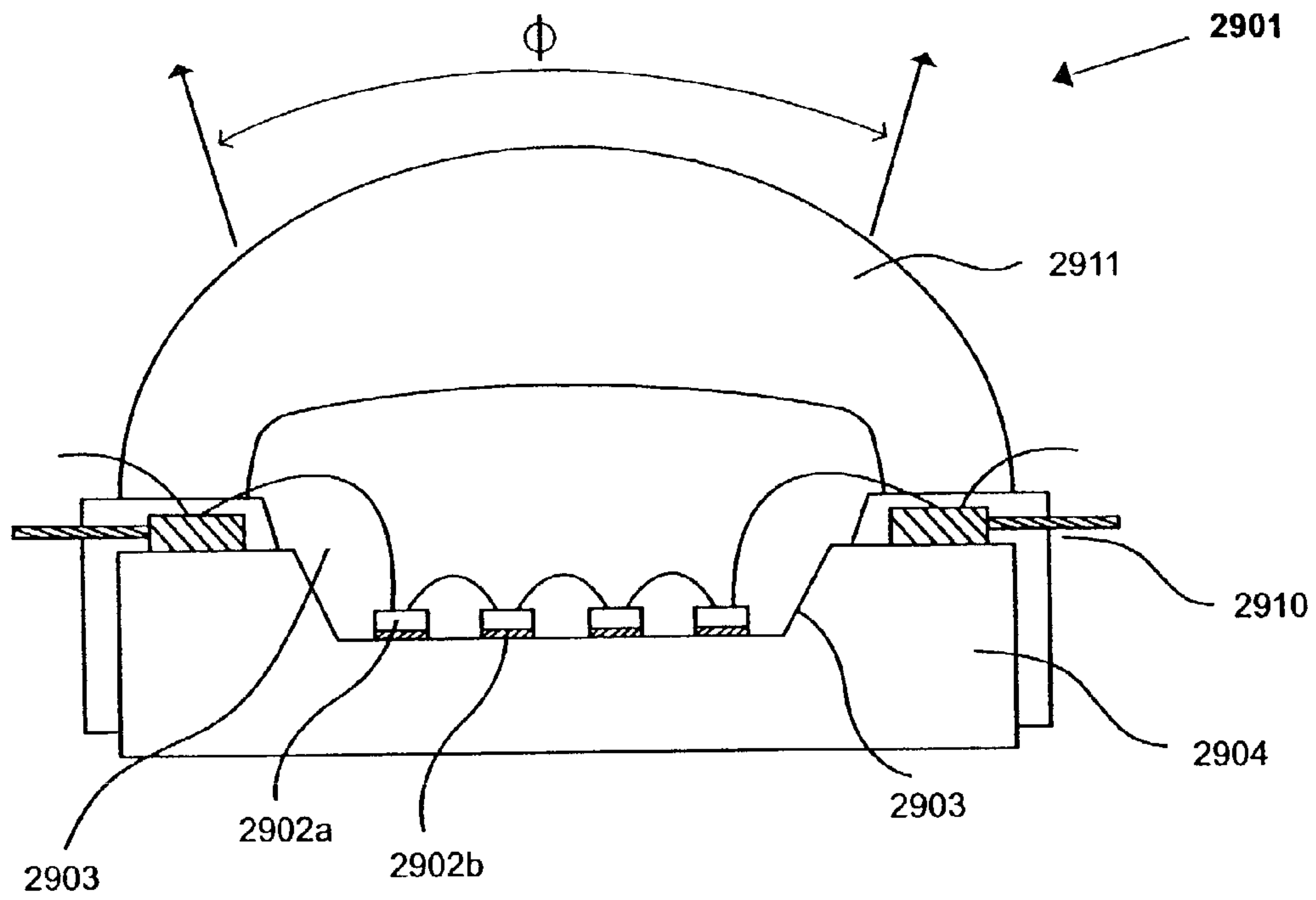

Fig. 29a

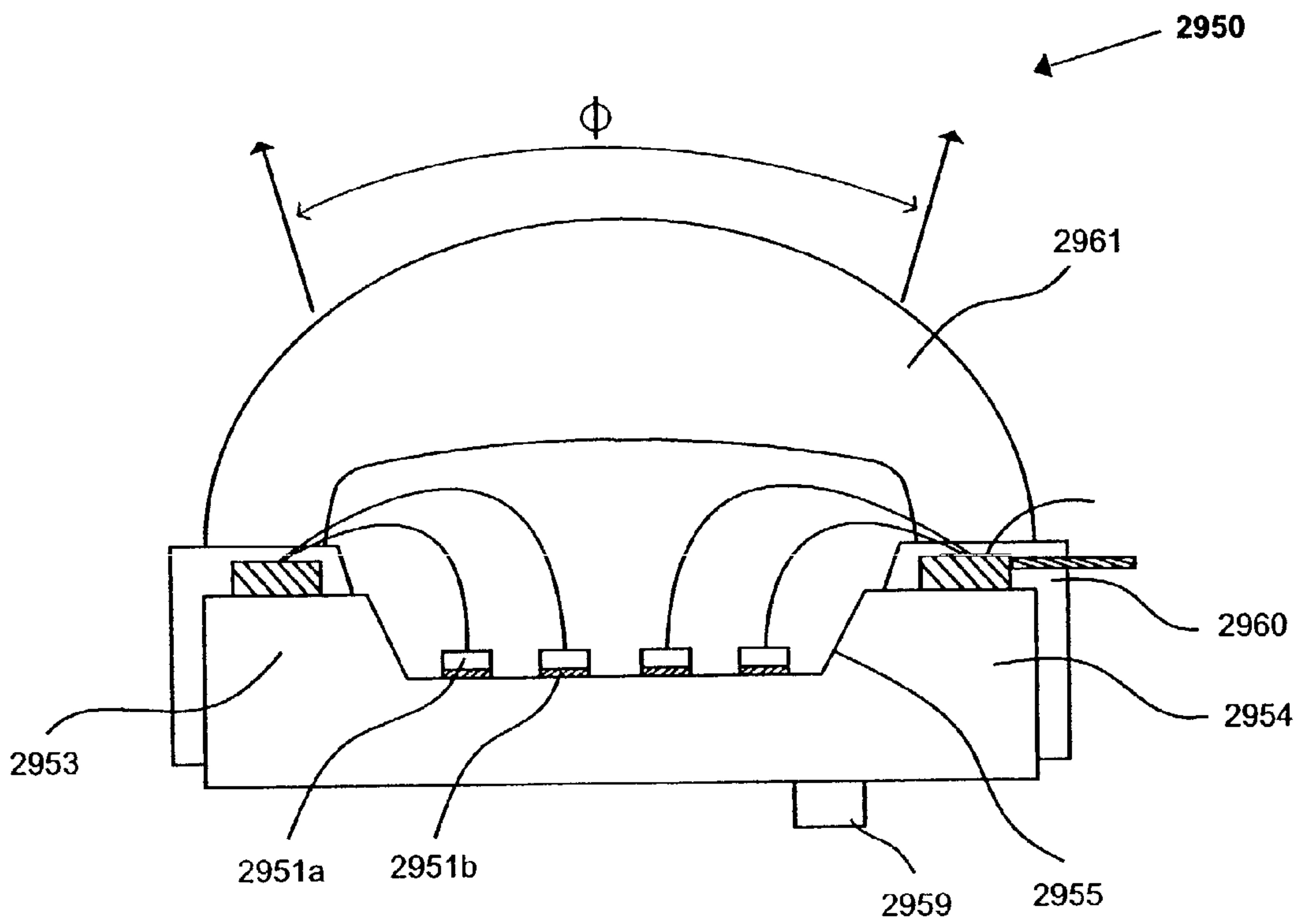

Fig. 29b

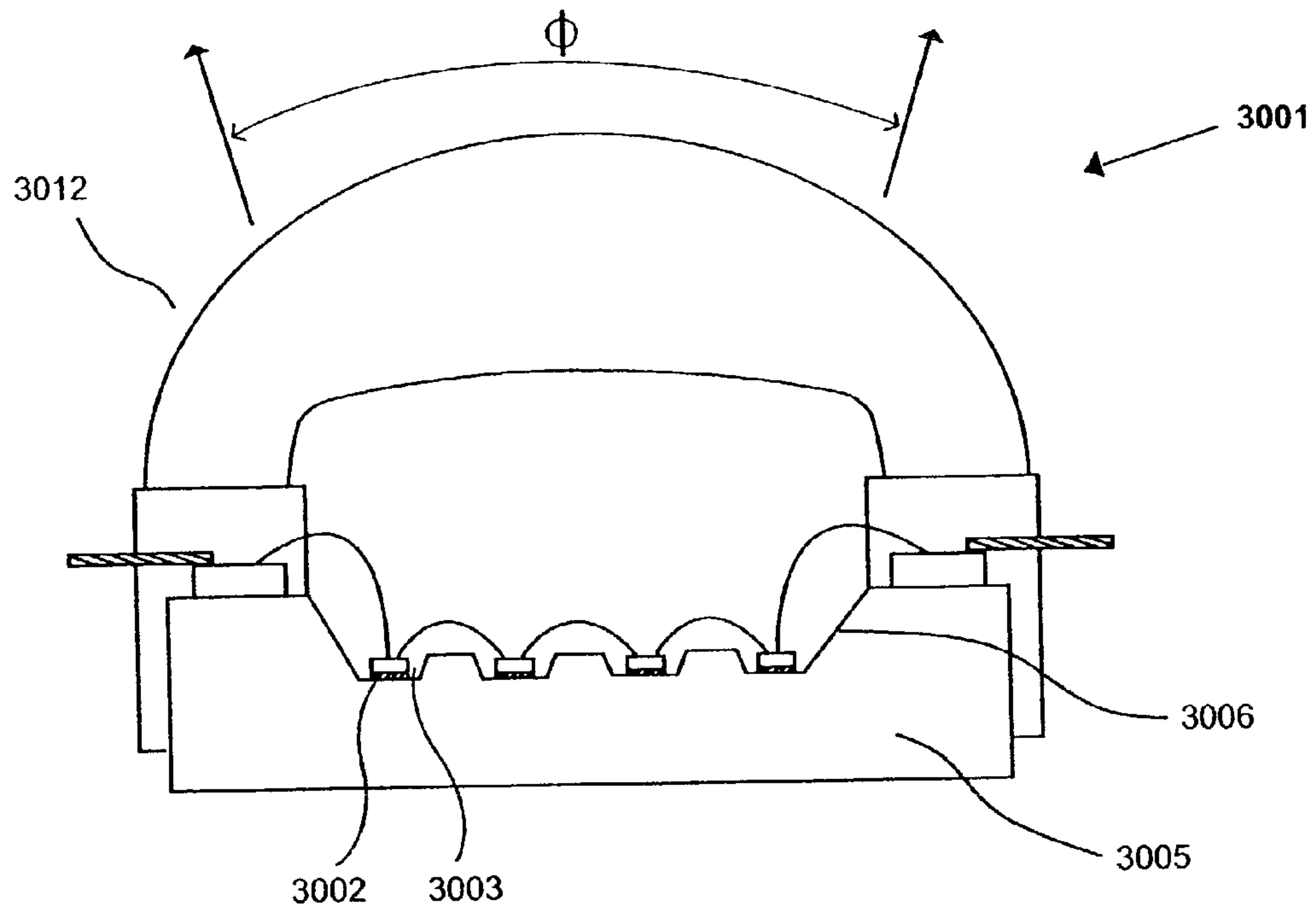

Fig. 30a

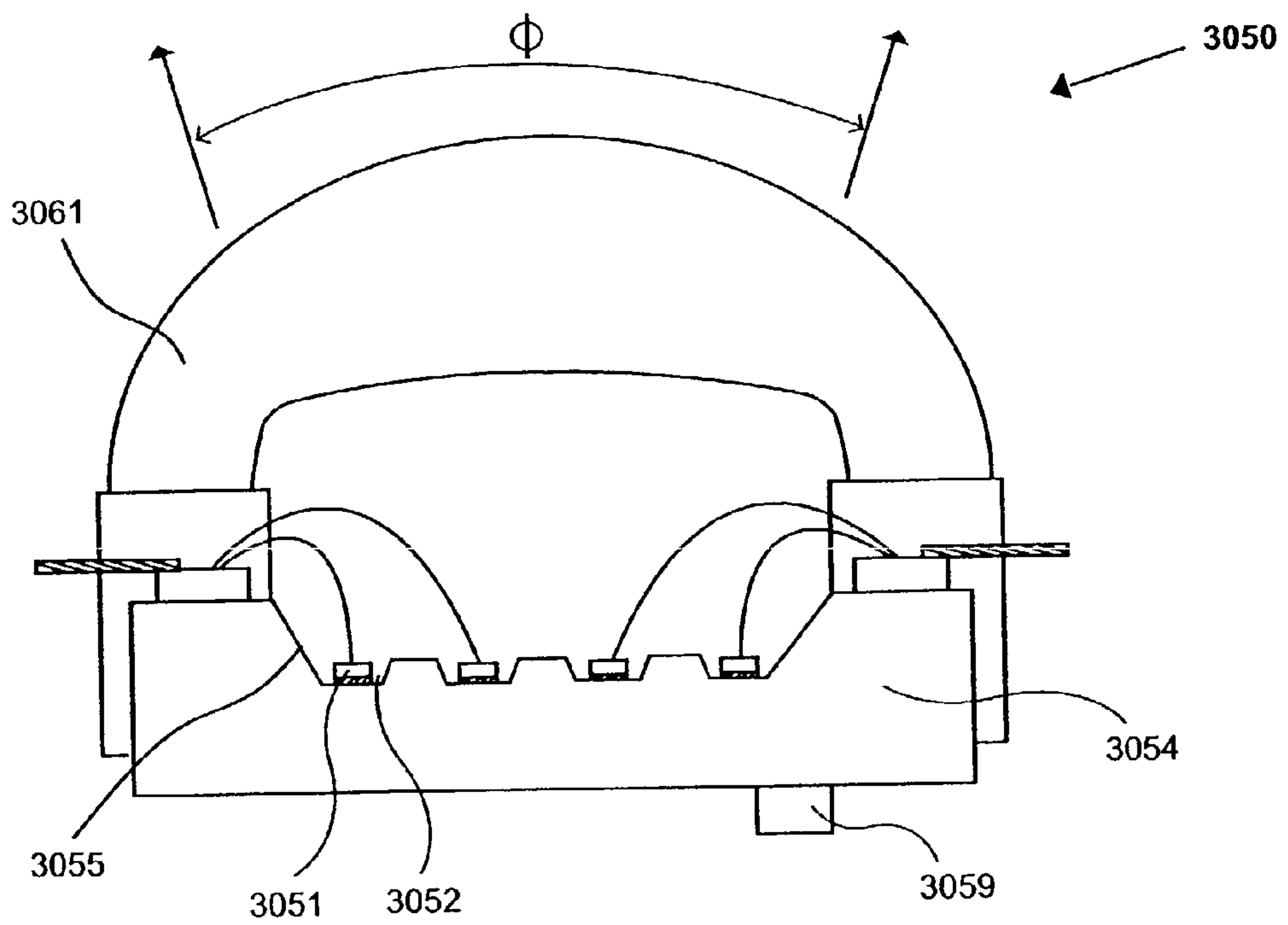

Fig. 30b

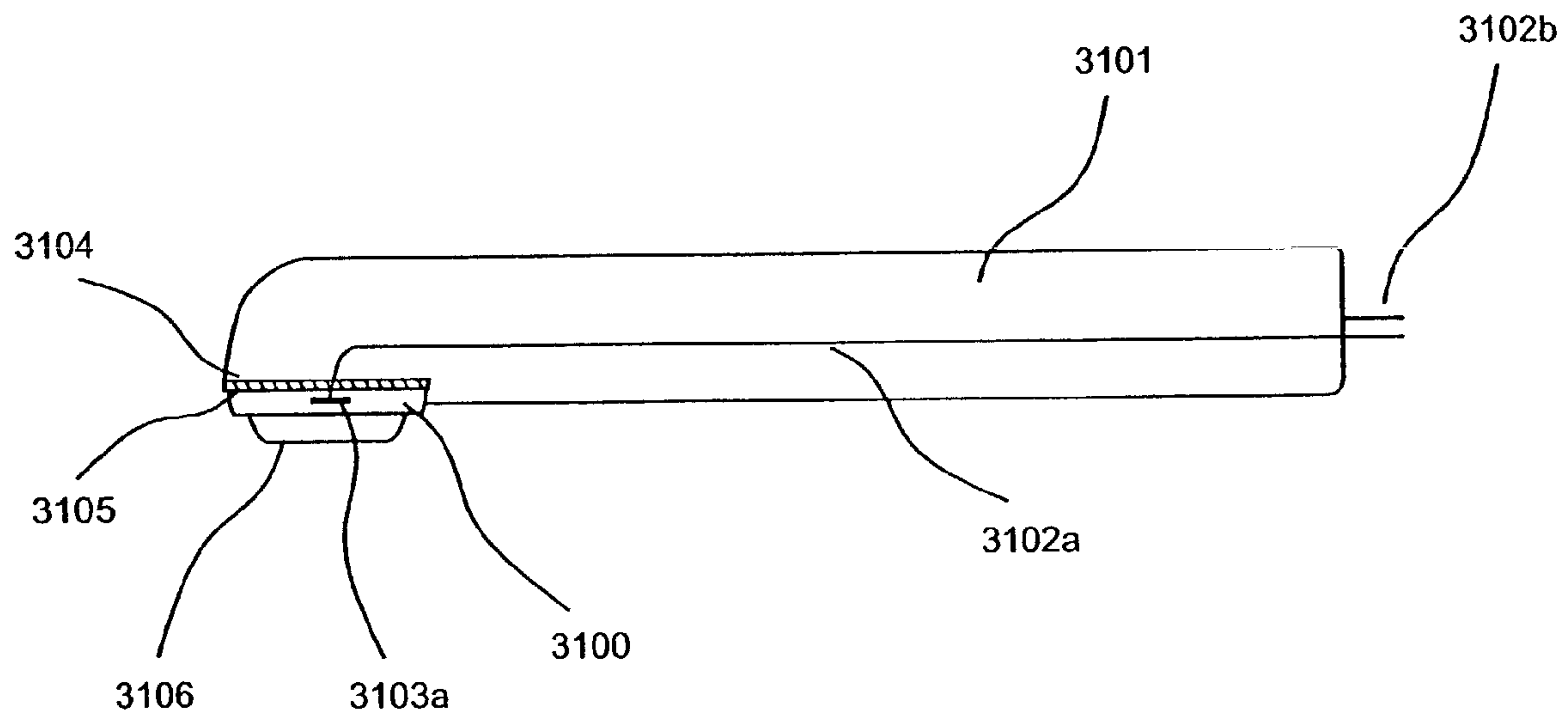

Fig. 31a

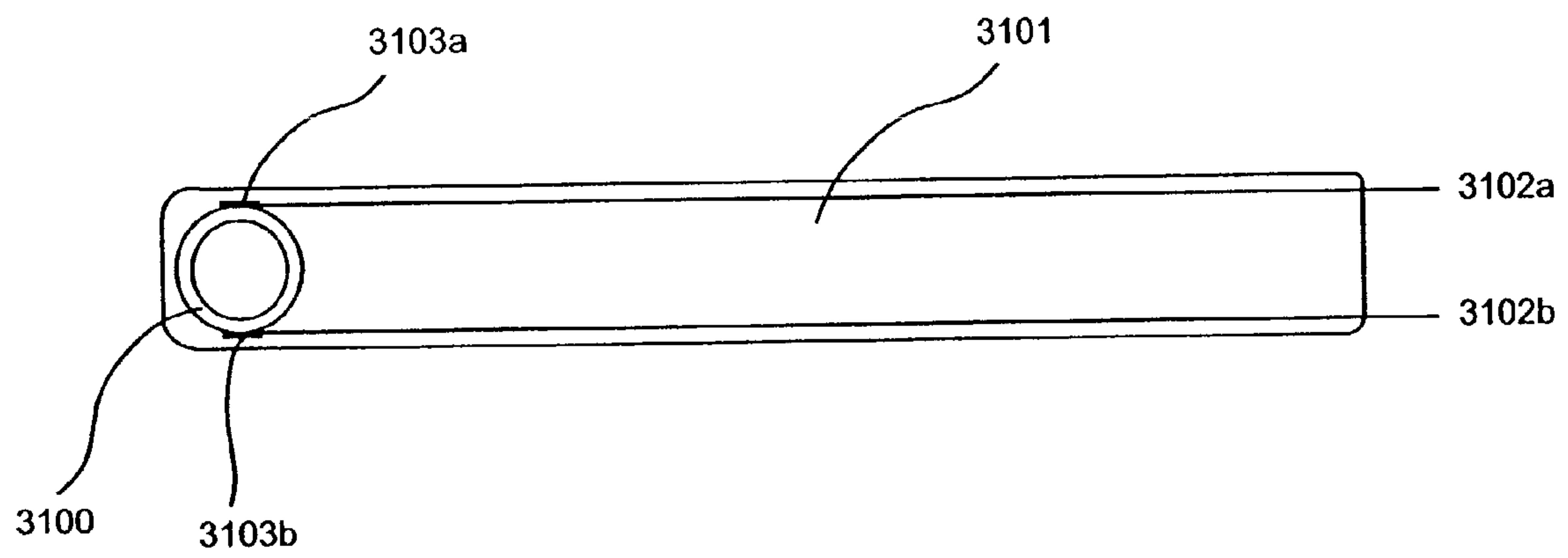

Fig. 31b

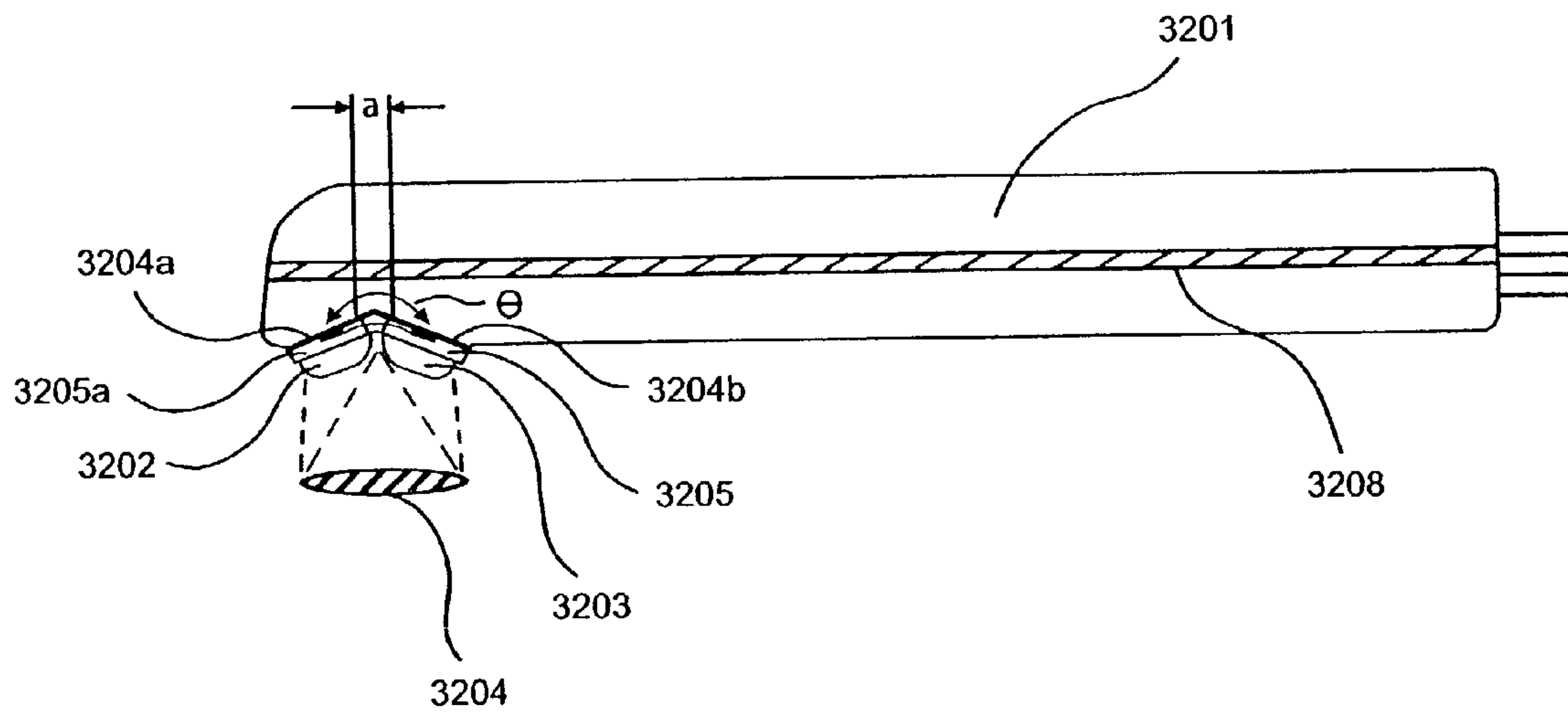

Fig. 32a

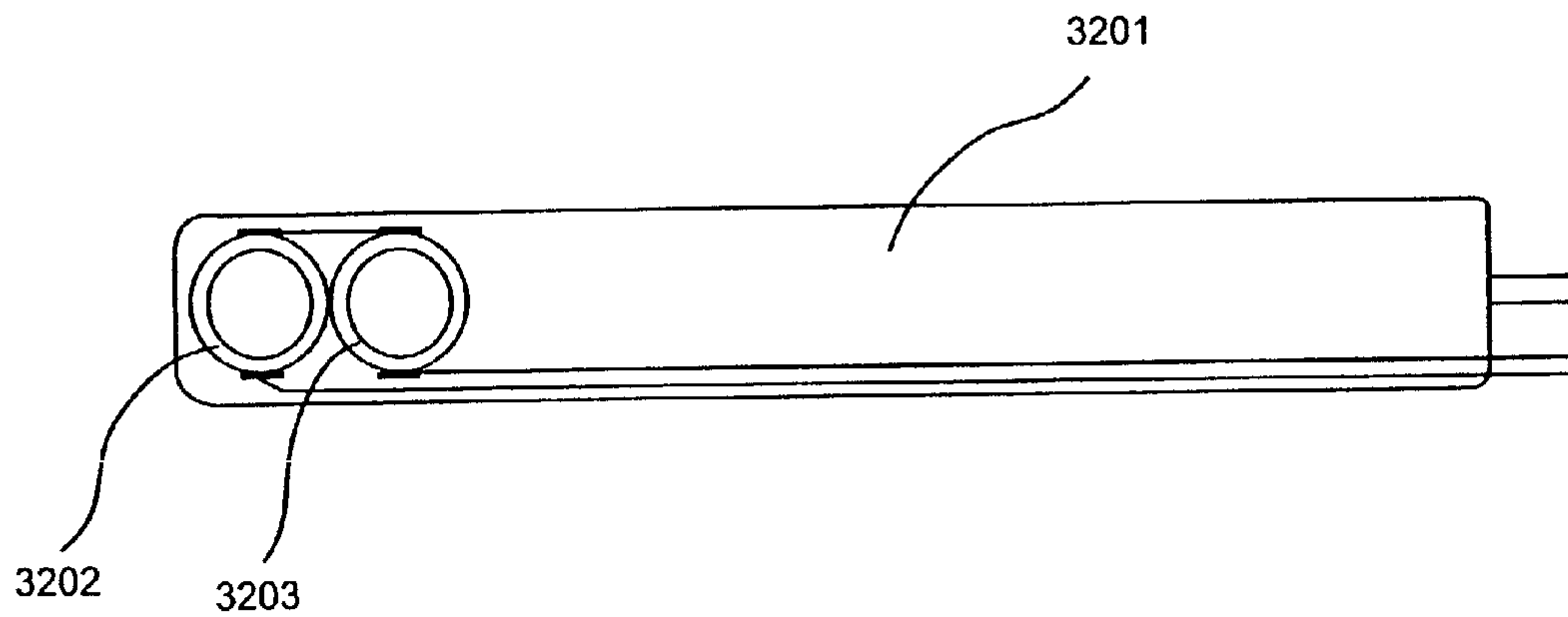

Fig. 32b

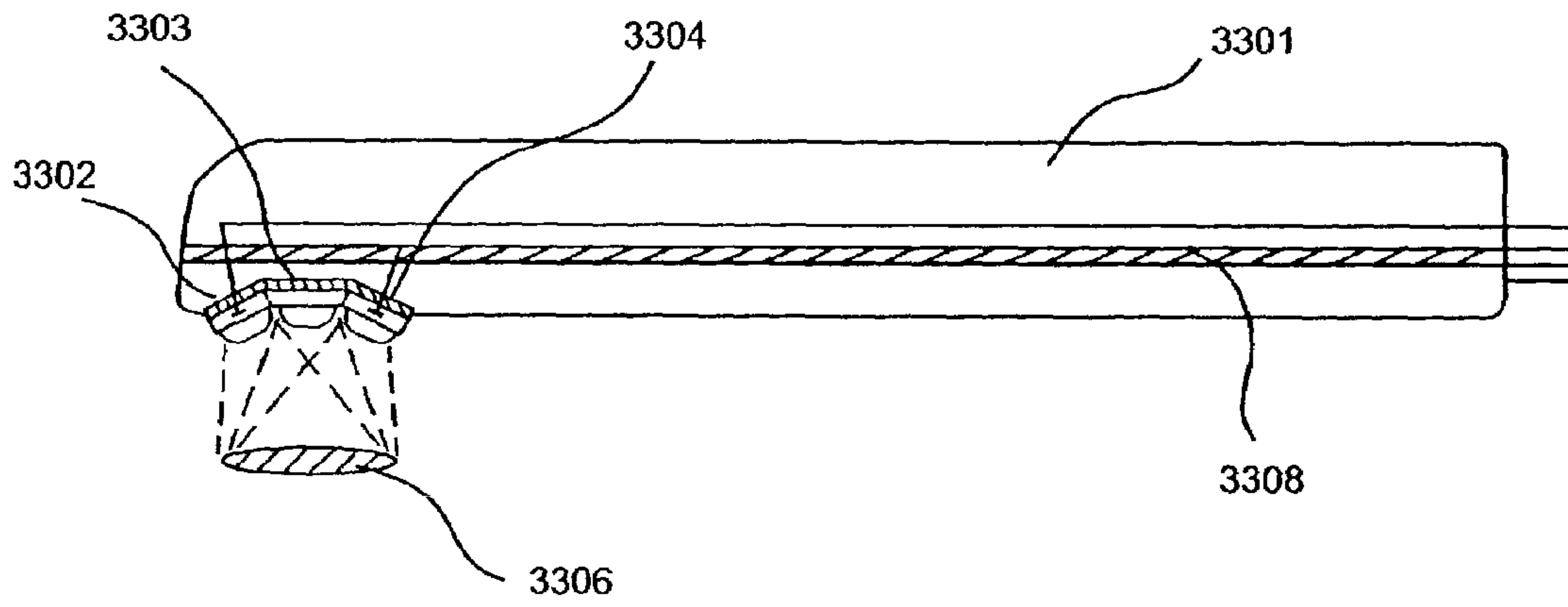

Fig. 33a

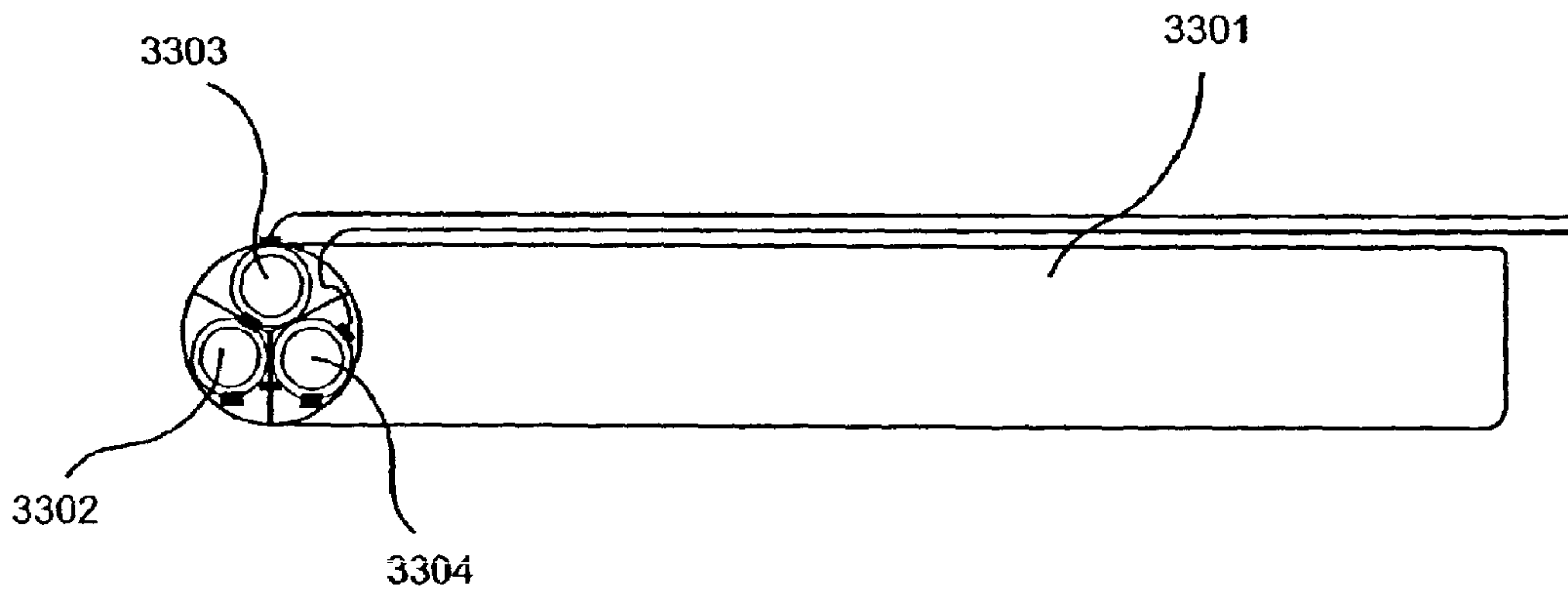

Fig. 33b



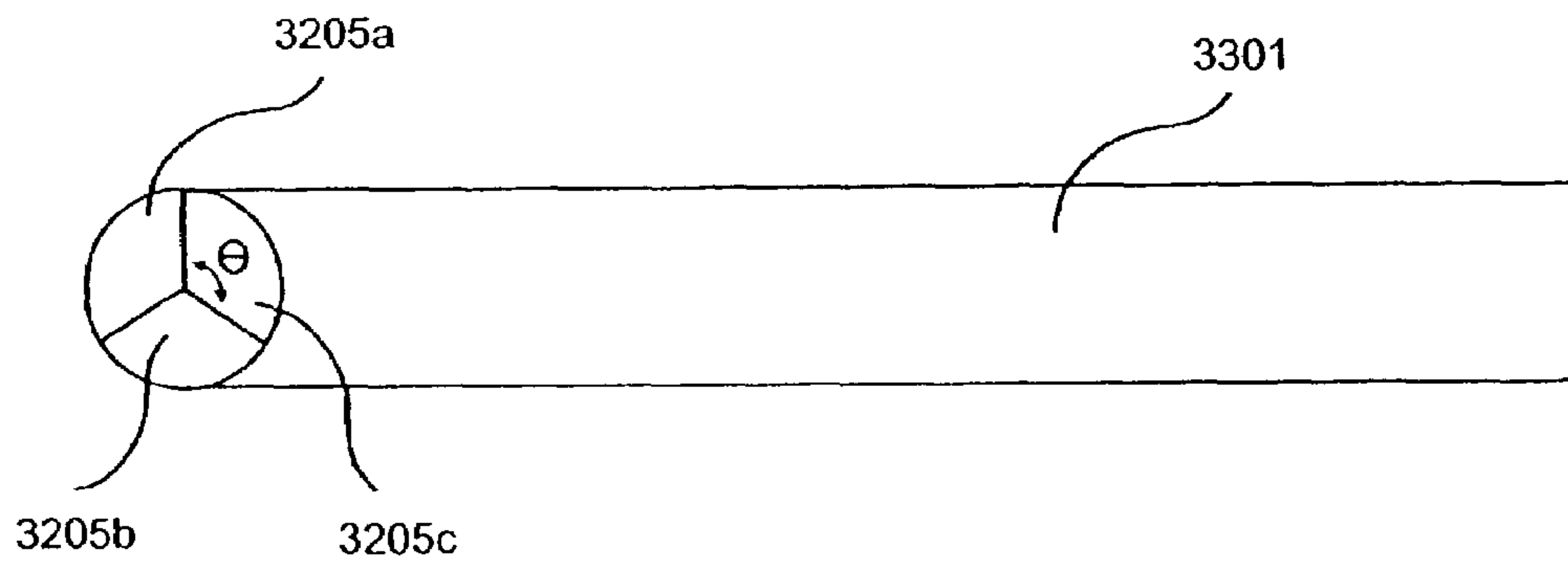

Fig. 33c

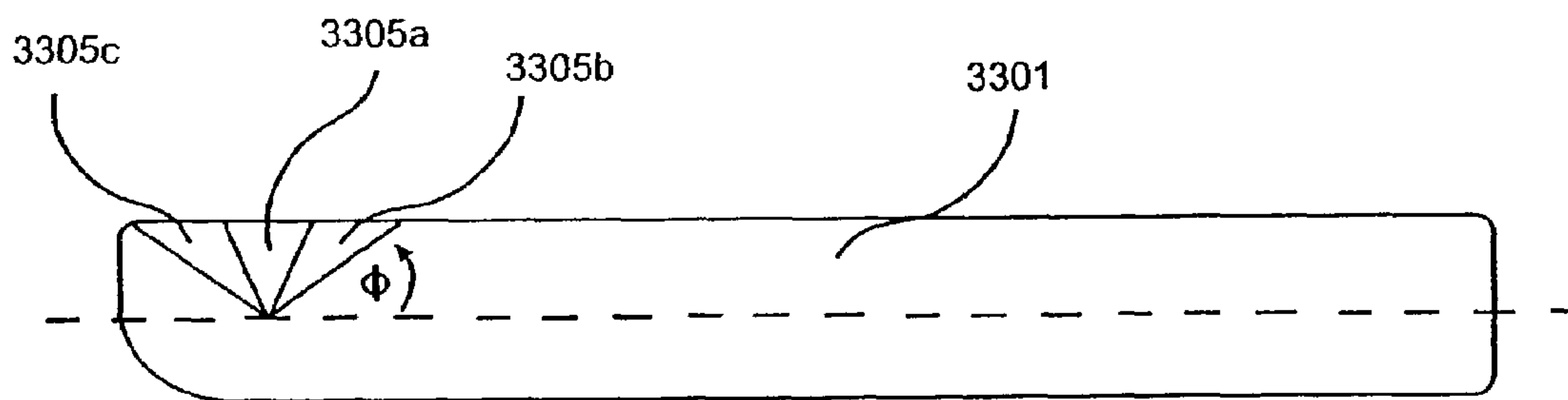
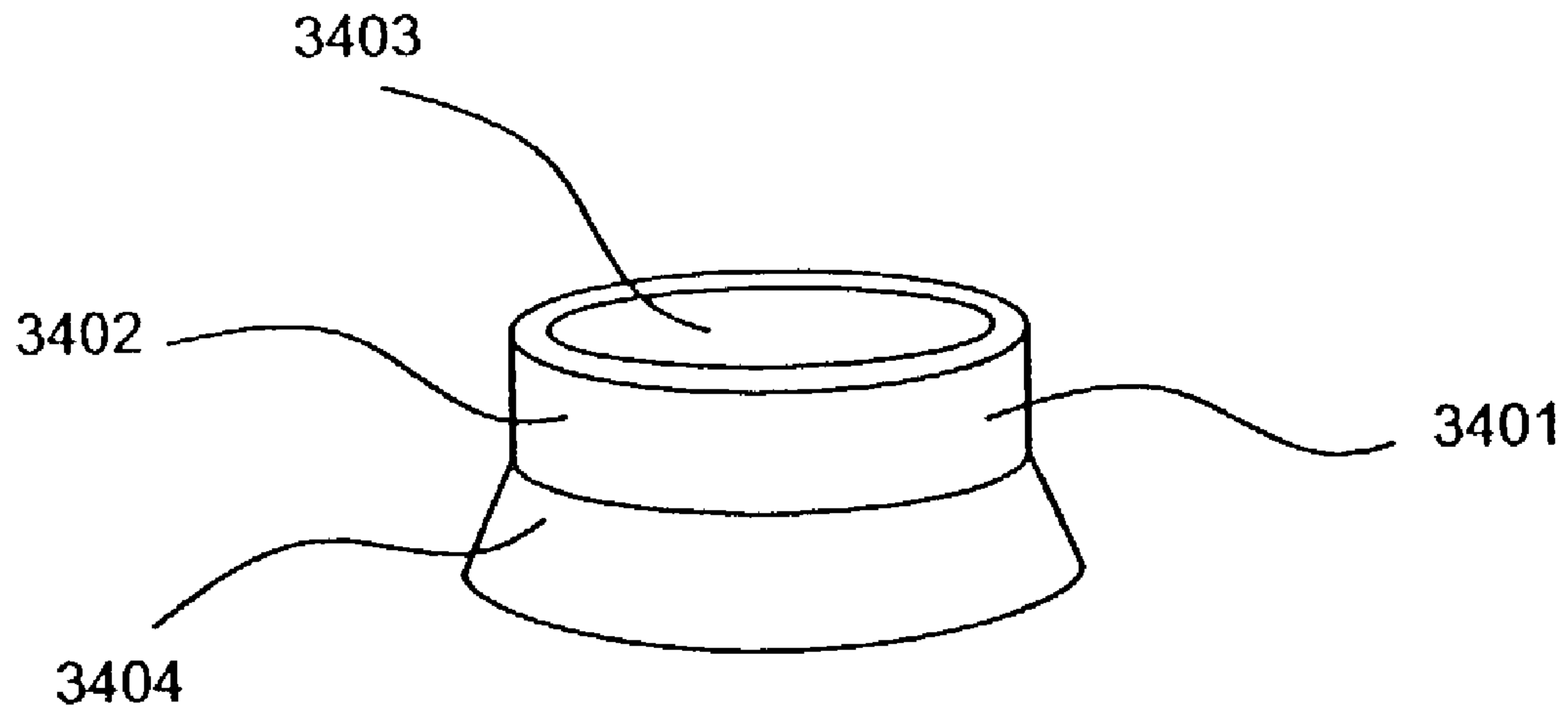
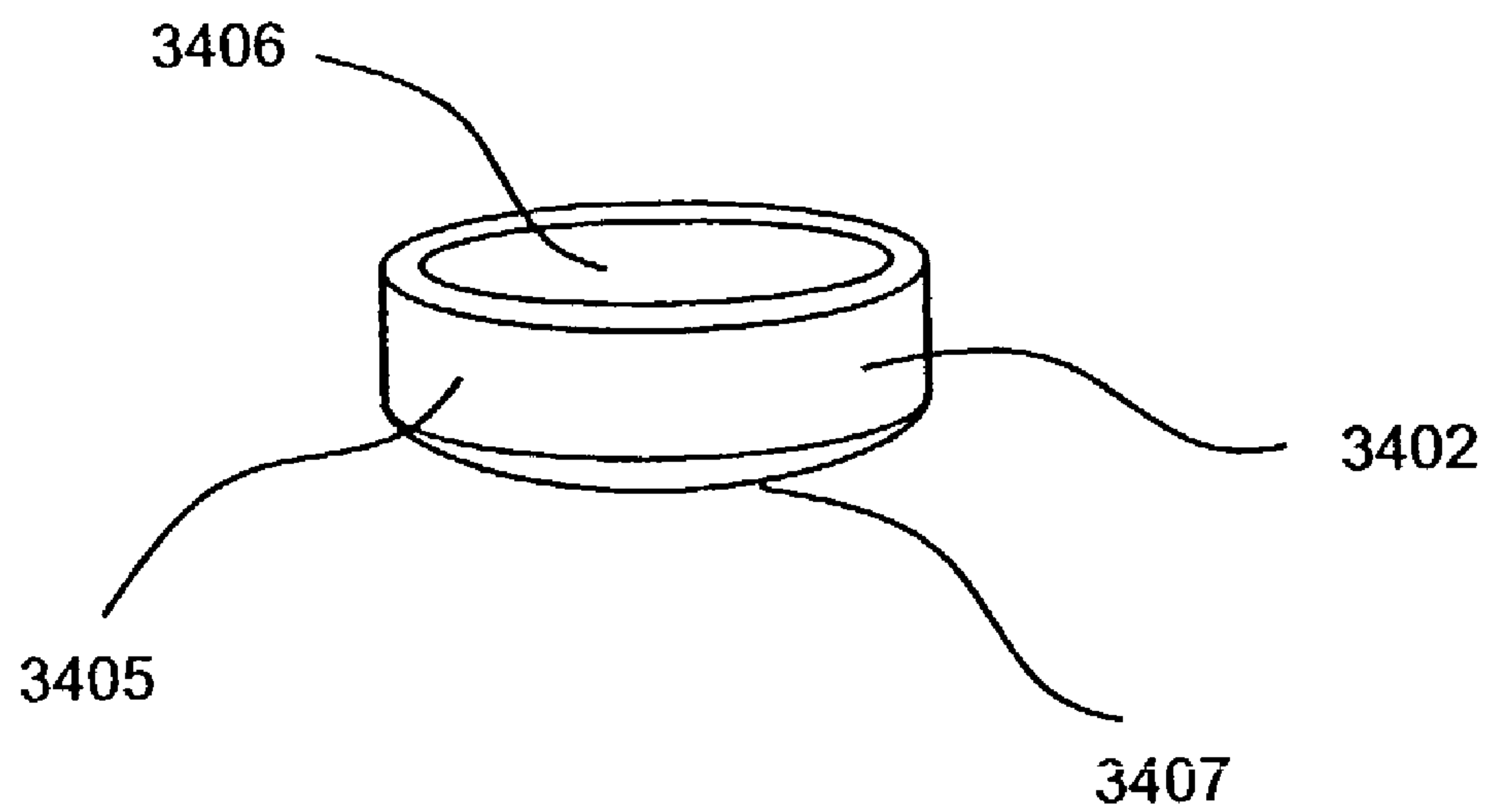

Fig. 33d



**Fig. 34a**



**Fig. 34b**

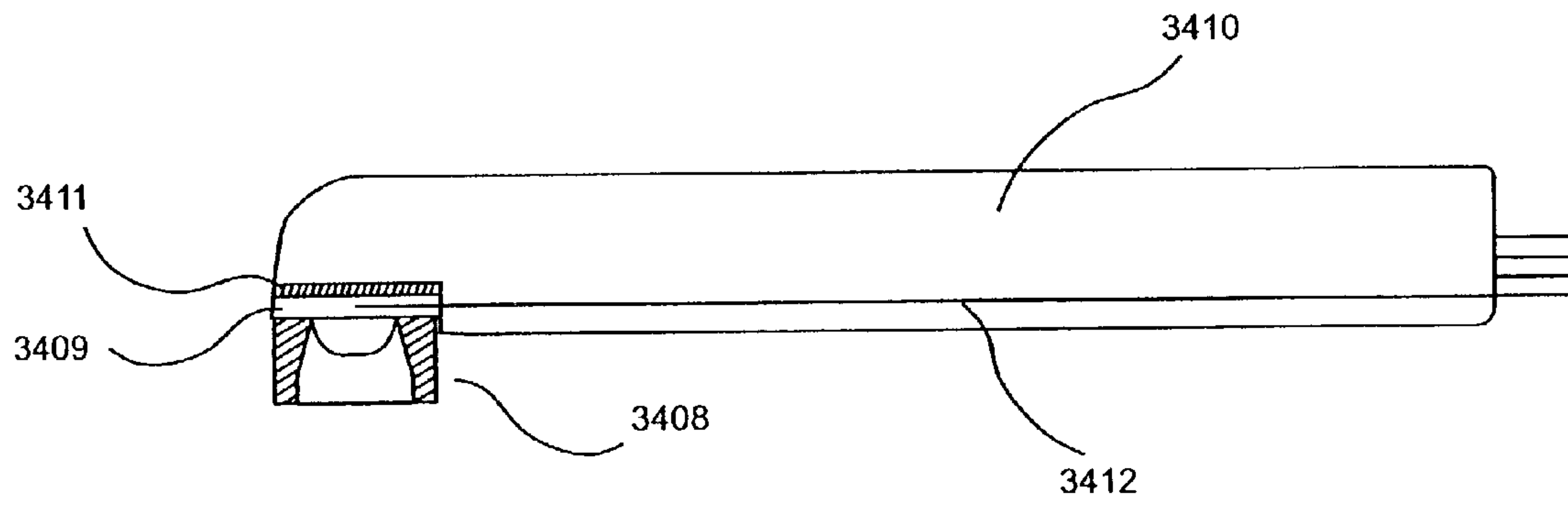

Fig. 34c

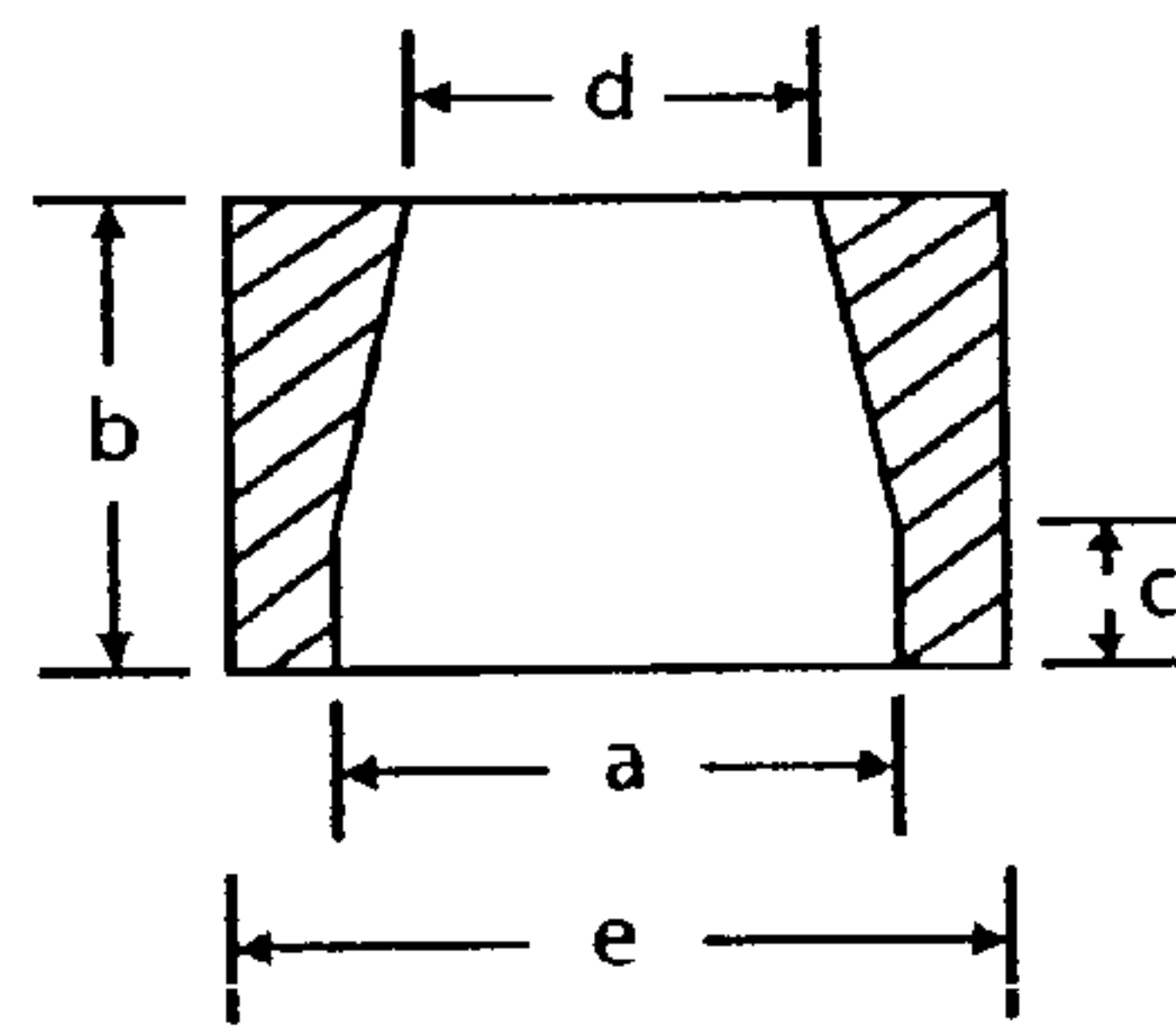

Fig. 34d

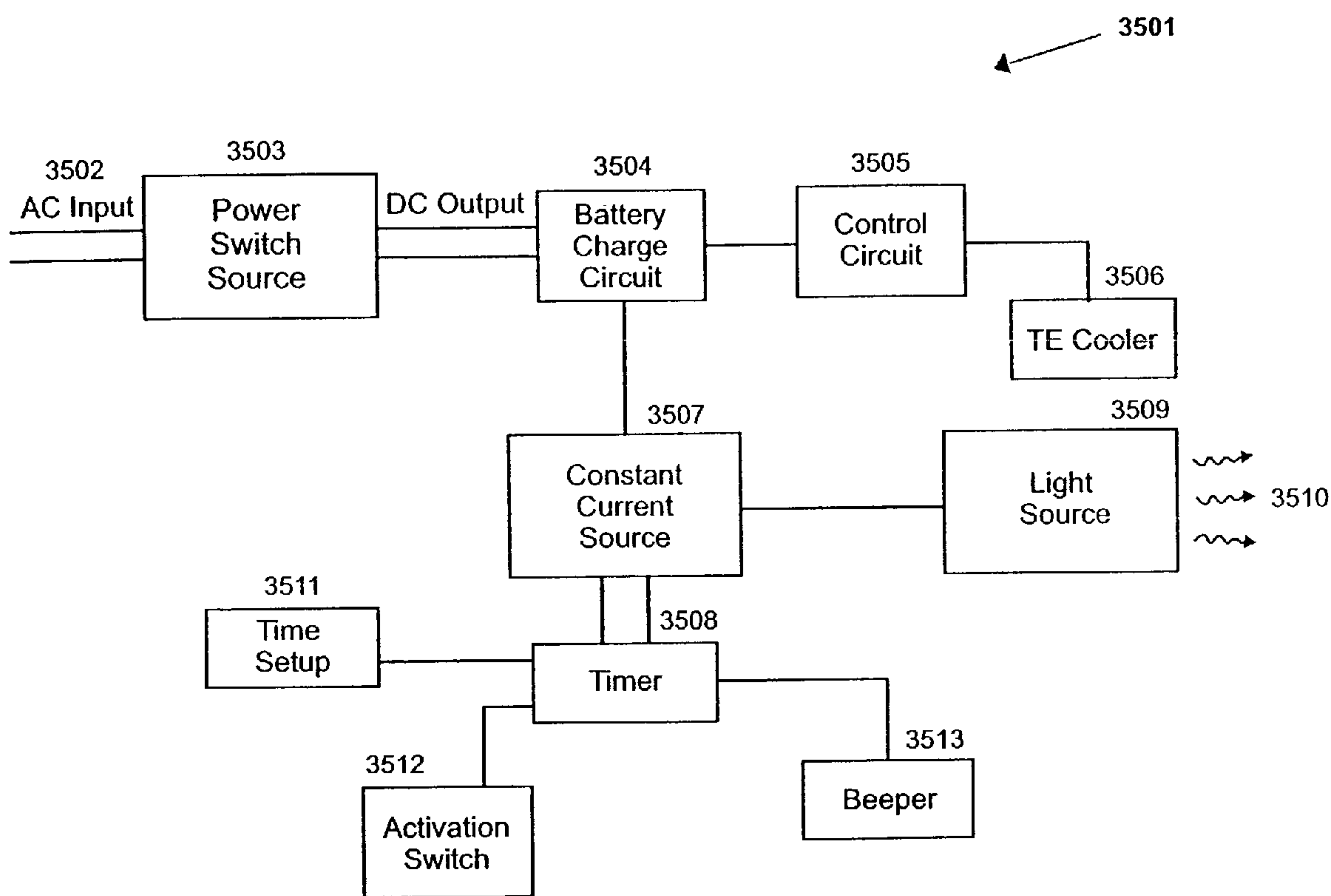

Fig. 35

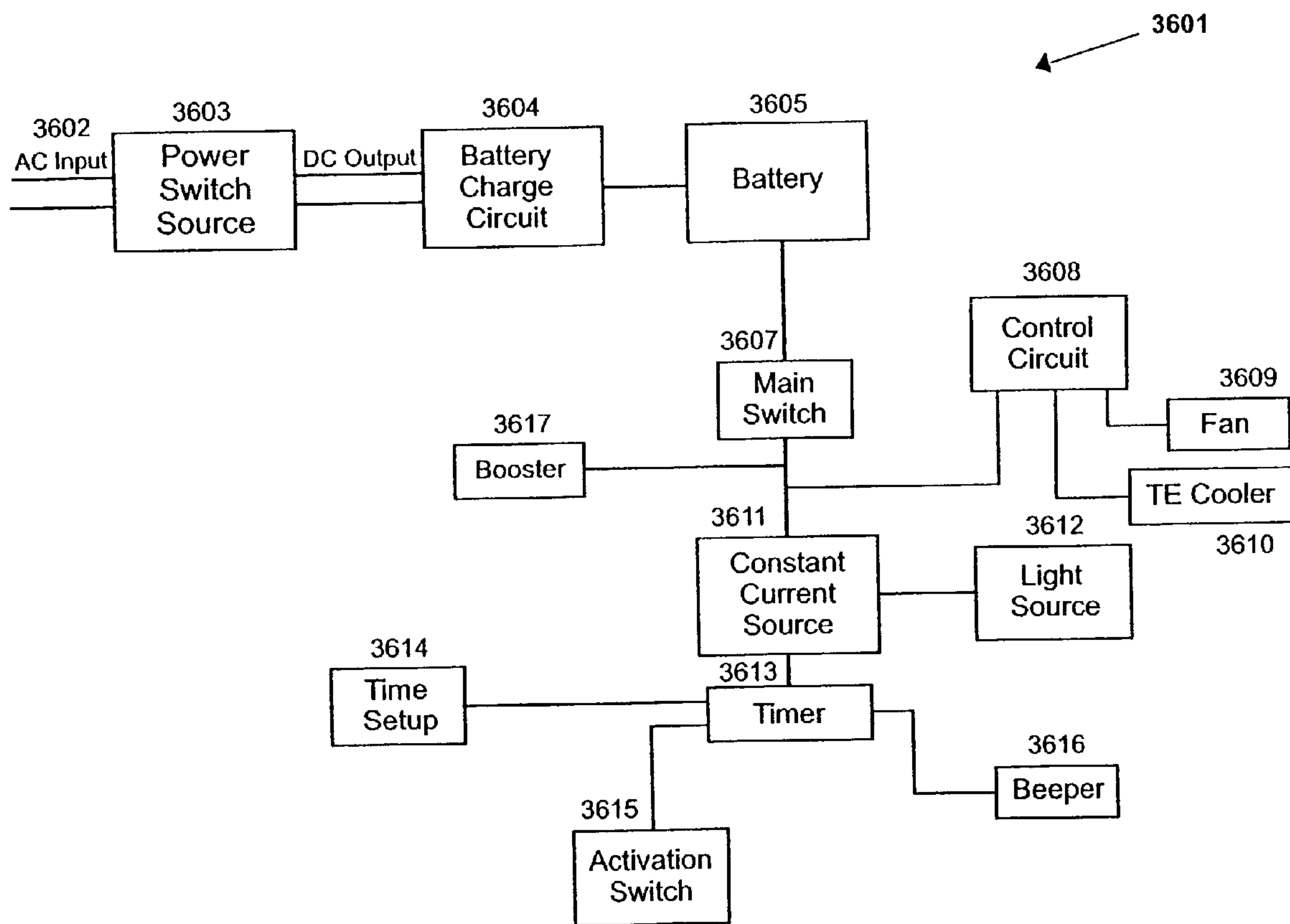

Fig. 36

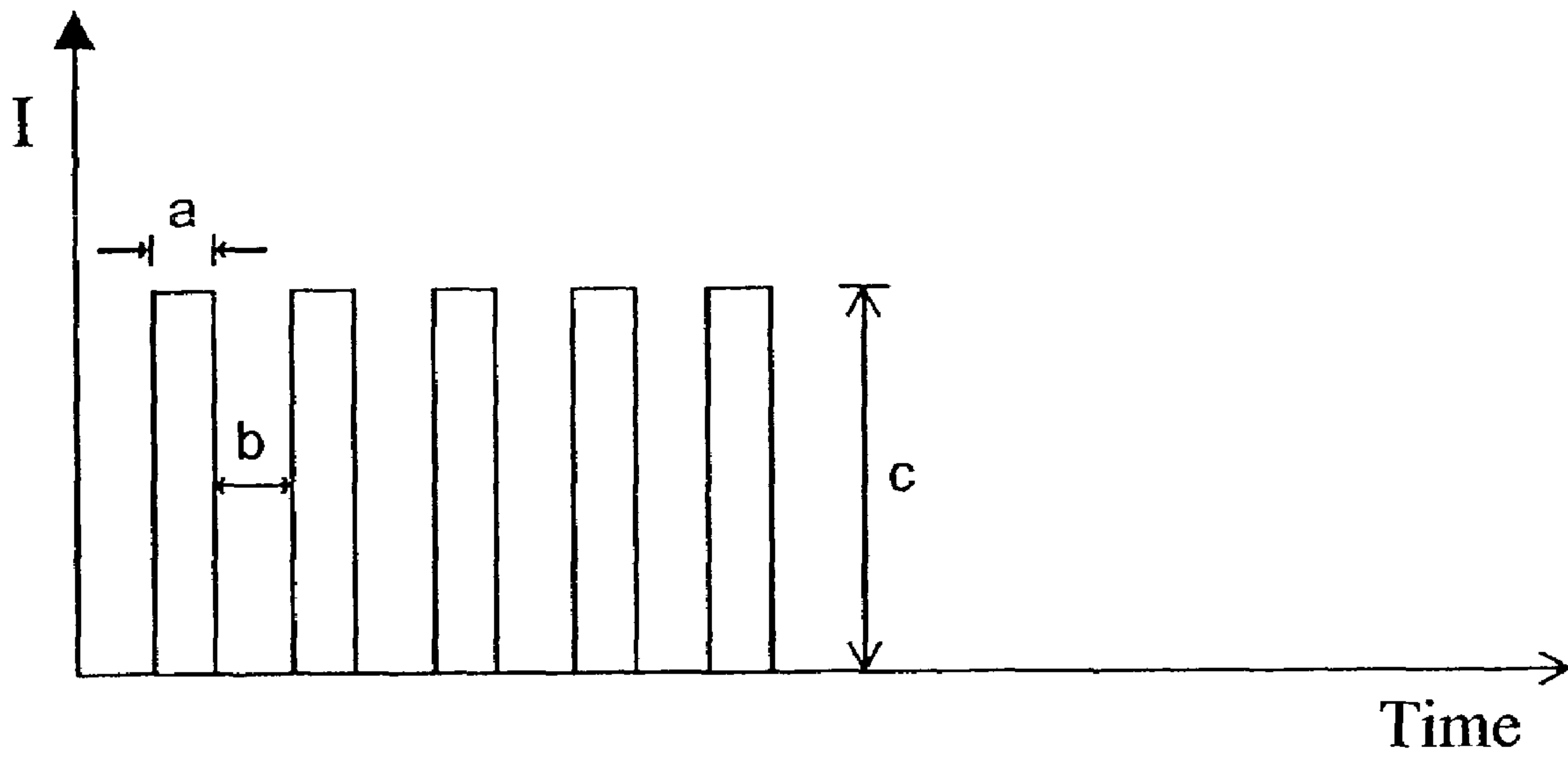

Fig. 37



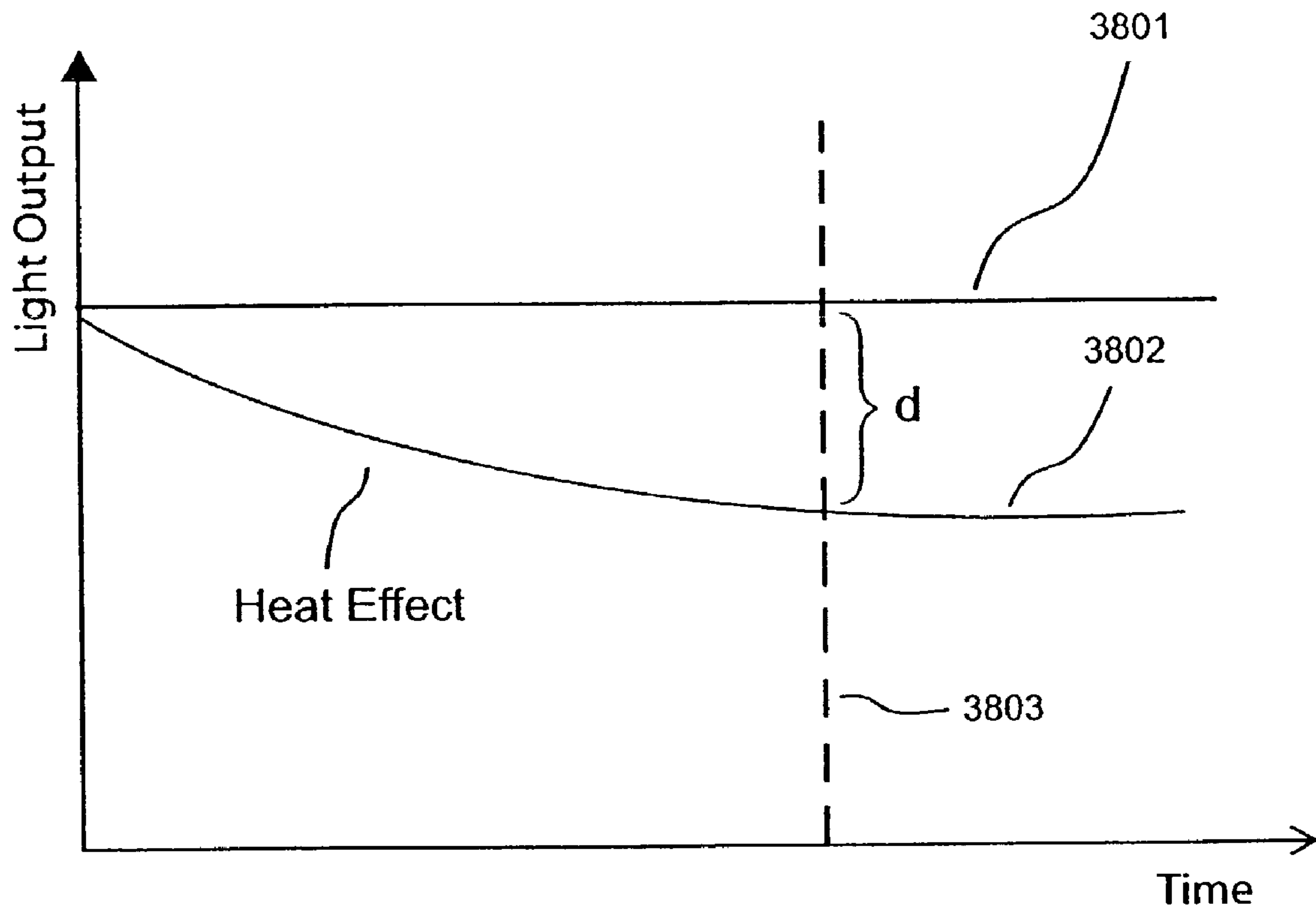

Fig. 38

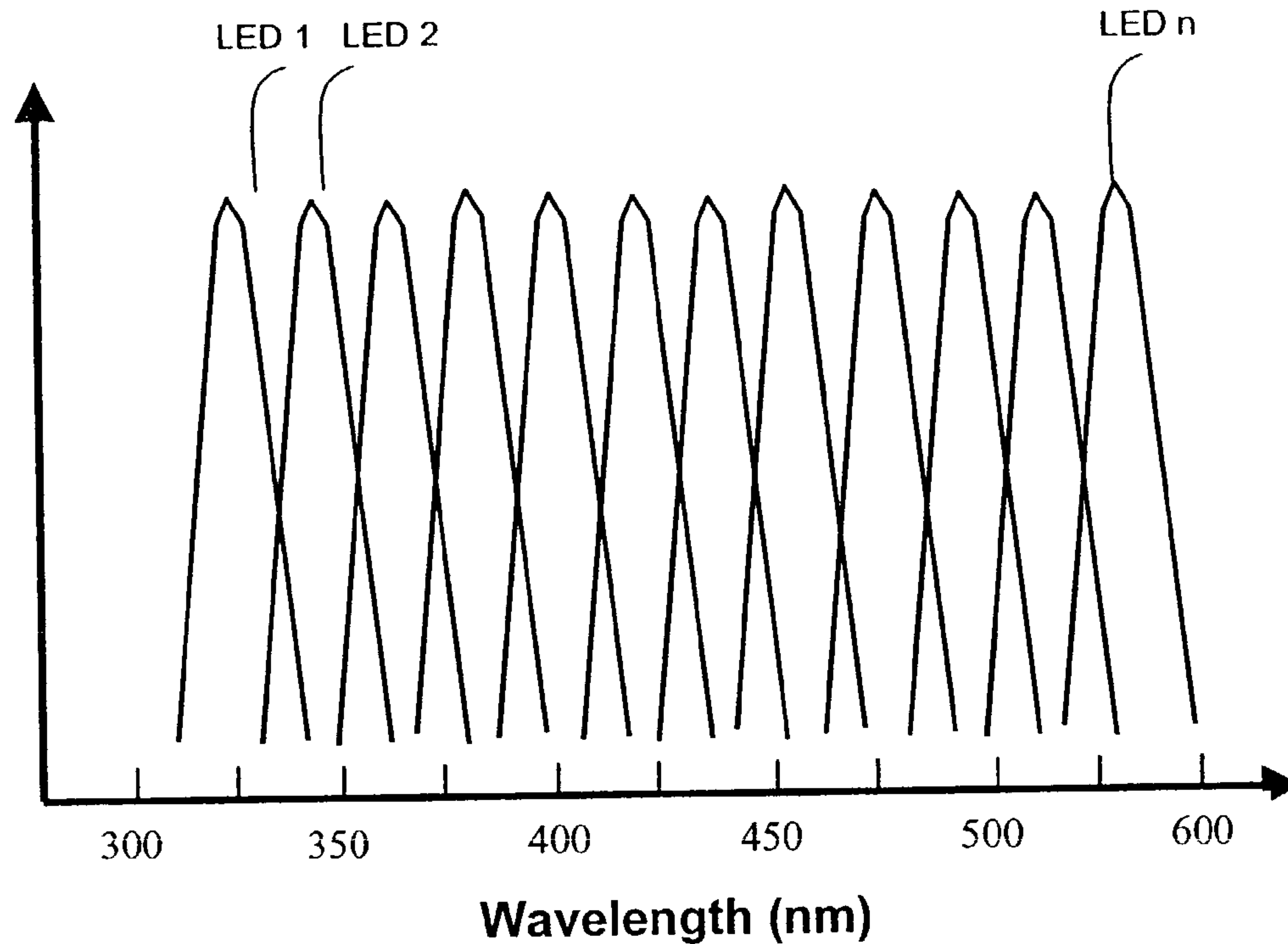

Figure 39

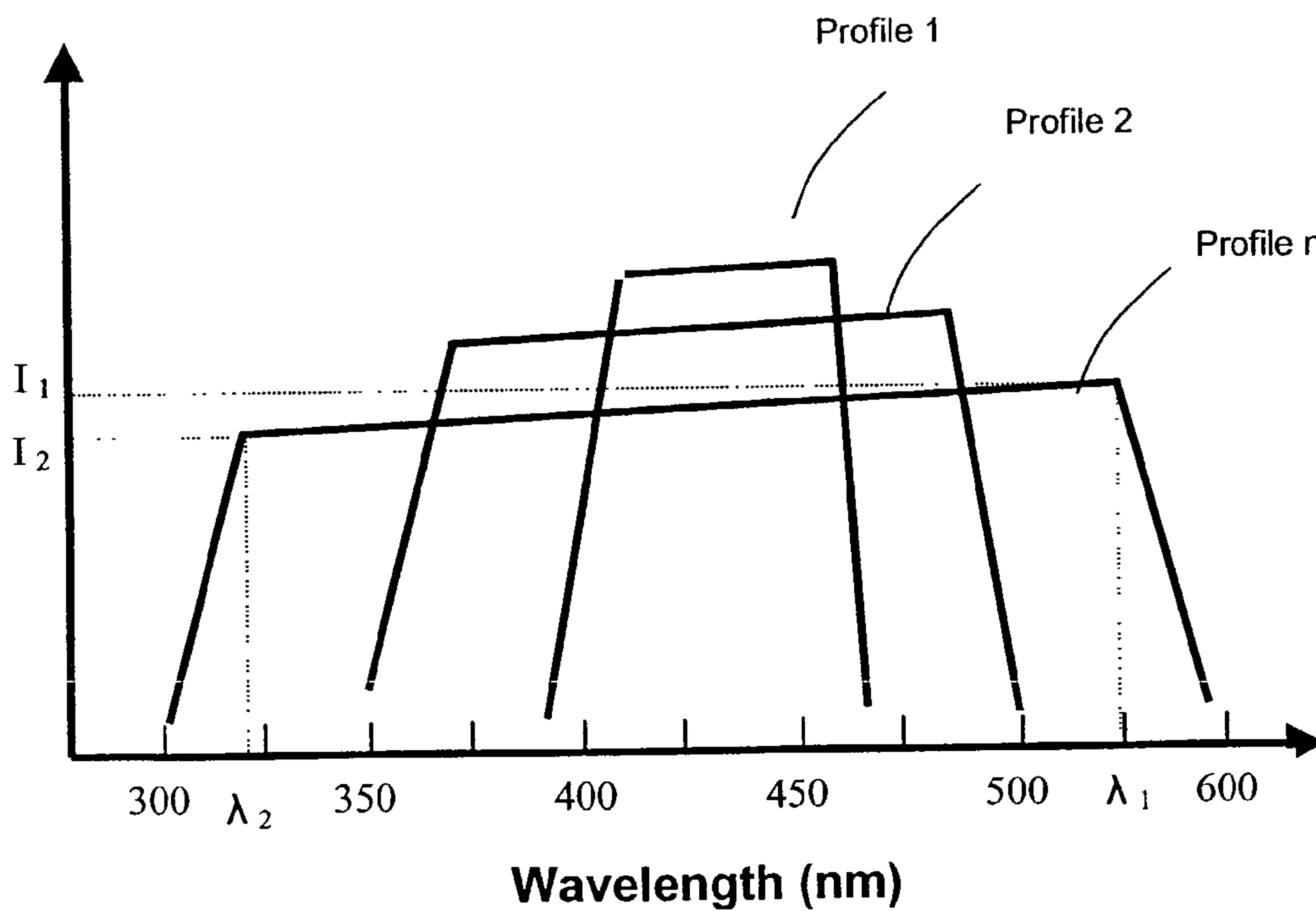

Figure 40

## 1

**LIGHT FOR ACTIVATING  
LIGHT-ACTIVATED MATERIALS, THE  
LIGHT INCLUDING A PLURALITY OF  
INDIVIDUAL CHIPS AND PROVIDING A  
PARTICULAR SPECTRAL PROFILE**

CROSS-REFERENCE TO RELATED  
APPLICATIONS

This patent application is a continuation-in-part of U.S. patent application Ser. No. 10/067,692 filed on Feb. 4, 2002, now U.S. Pat. No. 6,755,648; U.S. patent application Ser. No. 10/072,850 filed on Feb. 5, 2002; U.S. patent application Ser. No. 10/072,659 filed on Feb. 5, 2002; U.S. patent application Ser. No. 10/072,853 filed on Feb. 5, 2002, now U.S. Pat. No. 6,755,649; U.S. patent application Ser. No. 10/072,859 filed on Feb. 5, 2002, now U.S. Pat. No. 6,780,010; U.S. patent application Ser. No. 10/072,613 filed on Feb. 5, 2002; U.S. patent application Ser. No. 10/072,302 filed on Feb. 5, 2002; U.S. patent application Ser. No. 10/072,635 filed on Feb. 5, 2002; U.S. patent application Ser. No. 10/072,826 filed on Feb. 5, 2002; U.S. patent application Ser. No. 10/072,858 filed on Feb. 5, 2002; U.S. patent application Ser. No. 10/072,462 filed on Feb. 5, 2002; U.S. patent application Ser. No. 10/072,852 filed on Feb. 6, 2002; U.S. patent application Ser. No. 10/072,831 filed on Feb. 6, 2002; U.S. patent application Ser. No. 10/071,847 filed on Feb. 6, 2002; U.S. patent application Ser. No. 10/073,819 filed on Feb. 11, 2002, now U.S. Pat. No. 6,719,558; U.S. patent application Ser. No. 10/073,822 filed on Feb. 11, 2002; U.S. patent application Ser. No. 10/073,823 filed on Feb. 11, 2002; U.S. patent application Ser. No. 10/073,672 filed on Feb. 11, 2002; and U.S. patent application Ser. No. 10/076,128 filed on Feb. 12, 2002, now U.S. Pat. No. 6,719,559; each of which is a continuation-in-part of each of U.S. patent application Ser. No. 10/016,992 filed on Dec. 13, 2001; U.S. patent application Ser. No. 10/017,272 filed on Dec. 13, 2001, now U.S. Pat. No. 6,783,362; U.S. patent application Ser. No. 10/017,454 filed on Dec. 13, 2001; and U.S. patent application Ser. No. 10/017,455 filed on Dec. 13, 2001; each of which is a continuation-in-part of U.S. patent application Ser. No. 09/405,373 filed on Sep. 24, 1999, now U.S. Pat. No. 6,331,111, and priority is claimed to each of the foregoing. Priority is also claimed to U.S. Provisional Patent Application Ser. No. 60/304,324 filed on Jul. 10, 2001.

BACKGROUND

Lights that may be for activating light-activated materials are disclosed. There are various materials that are activated by light. For example, dental restorative materials, dental sealants and orthodontic adhesives may include monomers and a photoinitiator. The photoinitiator may be sensitive to light of a particular wavelength, and when exposed to light of that wavelength of sufficient power and duration, activates the monomers so that they polymerize into a cured and durable polymer. Further, dental whiteners may be activated or accelerated by exposure to a particular light. In the medical field, light activated materials may include splints, stents, hard tissue restorations, and drugs which are activated within the human body by exposure to a particular light. In the construction field, various adhesives, coatings, insulation, and sealants may be activated by particular light. A particular application of such technology would be the activation or curing of structural, repair or coating materials,

## 2

including underwater application of such materials, or application of such materials in space.

SUMMARY

Various lights and structures thereof and methods of using them are disclosed.

BRIEF DESCRIPTION OF THE DRAWINGS

FIG. 1 depicts a battery-powered light that uses a single light emitting diode chip as a light source.

FIG. 2 depicts a cross-section of the light of FIG. 1.

FIG. 3 depicts an AC-powered light that uses a single light emitting diode chip as a light source.

FIG. 4 depicts a cross section of the light of FIG. 3.

FIG. 5 depicts a battery-powered light that uses two light emitting diode chips as a light source.

FIG. 6 depicts a cross-section of the light of FIG. 5.

FIG. 7 depicts an AC-powered light that uses two light emitting diode chips as a light source.

FIG. 8 depicts a cross-section of the light of FIG. 7.

FIG. 9 depicts a battery-powered light that uses three light emitting diode chips as a light source.

FIG. 10 depicts a cross-section of the light of FIG. 9.

FIG. 11 depicts an AC-powered light that uses three light emitting diode chips as a light source.

FIG. 12 depicts a cross section of the light of FIG. 11.

FIG. 13 depicts a battery-powered light that uses three or more semiconductor chip modules mounted on a heat sink in a manner that the light they emit is collected by a reflector apparatus and focused by a lens means onto a light transport mechanism, such as a light guide, plastic stack or fiber.

FIG. 14 depicts a cross-section of the light of FIG. 13.

FIG. 15 depicts a variation of the light of FIG. 13, in the light transport mechanism is replaced by a distally-located mirror which reflects generally coherent light emitted from the light source in a desired direction for use.

FIG. 16a depicts a light which uses a plurality of light emitting semiconductor modules mounted on a heat sink as a light source, a focusing means to produce a generally coherent beam of light, and a light transport means such as optically conductive cable for transporting light to a location remote from the light source for use.

FIG. 16b depicts a cross section of the light of FIG. 16a.

FIG. 17a depicts a gross cross section of a light emitting diode chip that uses an insulative substrate.

FIG. 17b depicts a gross cross section of a light emitting diode chip that uses a conductive substrate.

FIG. 18a depicts epitaxial layers of a light emitting diode chip that uses an insulative substrate.

FIG. 18b depicts epitaxial layers of a light emitting diode chip that uses a conductive substrate.

FIG. 19a depicts a top view of a light emitting diode chip array (single chip) with an insulative substrate.

FIG. 19b depicts a top view of a top view of a light emitting diode chip array (single chip) with a conductive substrate.

FIG. 20a depicts a side view of a chip package for a light emitting chip that shows a light emitting diode chip with an insulative substrate mounted in a well of a heat sink, with electrical connections and light emission shown.

FIG. 20b depicts a perspective view of a chip package for a light emitting chip with an insulative substrate that shows a chip array mounted in a well of a heat sink.

FIG. 21a depicts a side view of a chip package for a light emitting chip that shows a light emitting diode chip with a



conductive substrate mounted in a well of a heat sink, with electrical connections and light emission shown.

FIG. 21*b* depicts a perspective view of a chip package for a light emitting chip with a conductive substrate that shows a chip array mounted in a well of a heat sink.

FIG. 22*a* depicts a side view of a chip package for a light emitting chip mounted in a well of a heat sink according to the so-called 'flip chip' design, the chip having an insulative substrate.

FIG. 22*b* depicts a side view of a flip chip mounted on a flip chip pad.

FIG. 22*c* depicts a perspective view of a flip chip pad.

FIG. 22*d* depicts a perspective view of the chip package of FIG. 22*a*.

FIG. 23 depicts a side view of a flip chip package with a conductive substrate.

FIG. 24*a* depicts a side view of a light emitting diode chip package including the chip (insulative substrate) and heat sink surface mount arrangement with a protective dome, lens or cover.

FIG. 24*b* depicts a side view of a light emitting diode chip package including the chip (conductive substrate) and heat sink surface mount arrangement with a protective dome, lens or cover.

FIG. 25*a* depicts an array of light emitting chips with insulative substrates in surface mount arrangement in a single well of a heat sink.

FIG. 25*b* depicts a perspective view of the array of surface-mounted chips of FIG. 25*a*.

FIG. 26*a* depicts an array of light emitting chips with conductive substrates in surface mount arrangement in a single well of a heat sink.

FIG. 26*b* depicts a perspective view of the array of surface-mounted chips of FIG. 26*a*.

FIG. 27*a* depicts an array of light emitting chips with insulative substrates in surface mount arrangement in individual sub-wells of a well of a heat sink.

FIG. 27*b* depicts a perspective view of the array of surface-mounted chips of FIG. 27*a*.

FIG. 28*a* depicts an array of light emitting chips with conductive substrates in surface mount arrangement in individual sub-wells of a well of a heat sink.

FIG. 28*b* depicts a perspective view of the array of surface-mounted chips of FIG. 28*a*.

FIG. 29*a* depicts a light emitting surface mount chip package including array of chips, heat sink and protective dome, lens or cover according to the chip and surface mount configuration of FIG. 25*a* above.

FIG. 29*b* depicts a light emitting surface mount chip package including array of chips, heat sink and protective dome, lens or cover according to the chip and surface mount configuration of FIG. 26*a* above.

FIG. 30*a* depicts a light emitting surface mount chip package including array of chips in sub-wells, heat sink and protective dome, lens or cover according to the chip and surface mount configuration of FIG. 27*a* above.

FIG. 30*b* depicts a light emitting surface mount chip package including array of chips in sub-wells, heat sink and protective dome, lens or cover according to the chip and surface mount configuration of FIG. 28*a* above.

FIG. 31*a* depicts a side view of a single surface mount light emitting diode chip mounted to an elongate heat sink in a manner such that light from the chip is emitted at generally a 90 degree angle to the longitudinal axis of the elongate heat sink.

FIG. 31*b* depicts a bottom view of the device of FIG. 31*a*.

FIG. 32*a* depicts a cross-sectional side view of an elongate heat sink having two light emitting semiconductor chips in surface mount configuration in an angled orientation in order to present overlapping light beams for an enhanced density light footprint.

FIG. 32*b* depicts a bottom view of the device of FIG. 32*a*.

FIG. 33*a* depicts a cross-sectional side view of an elongate heat sink having three light emitting semiconductor chips mounted on it in an angled orientation in order to present overlapping light beams for an enhanced density light footprint.

FIG. 33*b* depicts a bottom view of the device of FIG. 33*a*.

FIG. 33*c* depicts a bottom view of the heat sink of FIGS. 33*a* and 33*b* to permit the reader to understand the angular orientation of the light emitting semiconductor chips.

FIG. 33*d* depicts a side view of the heat sink for 3 surface mounted LED's.

FIG. 34*a* depicts a light shield which may be used to shield human eyes from light emitting by the light.

FIG. 34*b* depicts a focus lens which may be used to focus light in order to present a denser light footprint.

FIG. 34*c* depicts a light module with reflective cone installed.

FIG. 34*d* depicts a reflective cone.

FIG. 35 depicts a block diagram of control circuitry that may be used with lights that utilize AC power.

FIG. 36 depicts by a block diagram of control circuitry that may be used with lights that utilize battery power.

FIG. 37 depicts a graph of electrical current input *I* to the light emitting semiconductor chip(s) of the light versus time in a pulsed power input scheme in order to enhance light power output from the chip(s) and in order to avoid light intensity diminution due to the heat effect.

FIG. 38 depicts a graph of total light intensity output versus time in order to permit the reader to compare light intensity output when a current input pulsing scheme such as that of FIG. 37 is used to a traditional continuous wave current input approach which generates a heat effect is used.

FIG. 39 depicts a spectral output of a light with several chips, the chips having different peak wavelengths.

FIG. 40 depicts overall spectral profile patterns of multi-chip lights in which the chips output different peak wavelengths.

#### DETAILED DESCRIPTION

Various light systems useful for activating light-activated materials are disclosed. The invented light systems have application in a variety of fields, including but not limited to medicine and dentistry where light-activated materials with a photoinitiator are used. A photoinitiator may be used to absorb light of a particular wavelength and cause polymerization of monomers into polymers.

Light-activated materials can be applied to a surface and later cured by a variety of methods. One method includes use of a single photoinitiator or multiple photoinitiators in the light-activated material. After the light-activated material has been placed in a desired location, light of a wavelength that activates the photoinitiator is applied to the light-activated material. The light activates the photoinitiator and initiates a desired reaction, such as polymerization, activation or curing of the light-activated material, or catalyzing a reaction. For some materials, in order to initiate or complete curing, the light used must be of a wavelength to which the photoinitiator is sensitive, the light should be of a power level that will cause curing, and the light should be applied to the light-activated material for a sufficient dura-



tion of time. Although the light used to activate the photoinitiator should be of a wavelength to which a photoinitiator is sensitive, the light can come from a variety of sources, including gas lasers solid state lasers, laser diodes, light emitting diodes, plasma-arc lights, xenon-arc lights, and conventional lamps. This document discloses light systems that use semiconductor chips as their source of light.

FIG. 1 depicts a battery-powered light **100** that uses a single light emitting diode chip as a light source. FIG. 2 depicts a cross-section of the light **100** of FIG. 1. The portable light system **100** includes a light source module **102** which generates light of a desired wavelength or multiple wavelengths for activating a photoinitiator or multiple photoinitiators and initiating curing of a light activated light-activated material. The light source module **102** has a light shield **103** for blocking light generated by the light emitting semiconductor chip(s) **150** from reaching human eyes and skin. The apparatus **103** could also be configured as a lens or focusing cone for modifying the footprint of light emitted by the light. The light emitting semiconductor chip(s) **150** are located at the distal end of the light, and at the distal end of the light source module **102**. The chip(s) **150** are oriented to emit light at generally a right angle with the longitudinal axis of the light source module or the longitudinal axis of the light handpiece, although chips could be mounted to emit light at from about a 45 degree angle to about a 135 degree angle with the longitudinal axis of the light source module, heat sink, or handpiece as desired. The light system **100** includes a housing **104** for containing and protecting electronic circuits and a DC battery pack. In some lights, the light emitting semiconductor chip(s) may be powered by from less than about 25 milliamps to more than about 2 amps of electrical current. Many lights can have chip(s) powered from about 350 milliamps to about 1.2 amps of current. Higher power lights may often use more than about 100 milliamps of current.

A switch **105a** is provided on the top of the housing **104** facing a direction opposite from the direction that light would be emitted from the light source module **103**. A second switch **105b** is provided on the side of the housing. The switches **105a** and **105b** are devices such as a button or trigger for turning the light emission of the light on and off. A timer **106** is provided to control the duration of time that the light emits a beam of light. Control buttons to set and adjust the timer are depicted as **151a** and **151b**.

An audible indicator or beeper may be provided in some lights to indicate when light emission from the light begins and ends. A first light emitting diode indicator lamp **107** is located on the housing in a visible location in order to indicate to the user low battery power. A second light emitting diode indicator lamp **108** is located on the housing in a visible location in order to indicate to the user that the battery is being charged. A main on/off switch to the light **160** is provided at the rear or proximal end of the housing. A wavelength selector may be provided in some lights so that the user may select the wavelength of light that he wishes to emit from the light, depending on the wavelength sensitivity of the photoinitiator in the light-activated material that he is using. The user may also select a combination of two or more wavelengths of light to be emitted together in some lights.

A separate battery charger module **109** may be included in order to receive AC power from a traditional wall socket and provide DC power to the light system for both charging the batteries and powering the light source and control circuitry when the batteries if desired. The battery charger module **109** has a cable **109a** and a plug **109b** for plugging into a

receptacle or connector **170** on the proximal end of the light housing **104**. The battery charger module **109** includes circuitry **109c** for controlling battery charging of batteries **166**.

The light module **102** has a casing **161** that encases an elongate heat sink **162**. The casing **161** is separated from the heat sink **162** by a buffer layer **163** such as insulation tape and an air space or air jacket may be provided therebetween for heat dissipation. Electrically conductive wires **164** to power the light-emitting semiconductor chip(s) **150**. Internally, we can see that the heat sink **162** is an elongate and curved structure which positions a semiconductor chip at its end in a convenient place for use without a light guide. At the distal end of the heat sink **162**, there may be a smaller primary heat sink or semiconductor chip module which includes a smaller primary heat sink. A semiconductor module may be covered by a protective cover or dome or a focus lens. The heat sink **162** may be an elongate structure or other shape as desired. Use of an elongate heat sink **162** rapidly transfer heat away from the chip(s) **150** for heat dissipation. If heat transfer and dissipation are not handled adequately, damage to the chip(s) **150** may result, or light output of the chip(s) **150** may be diminished.

The light source module **102** is removable from the housing **104** and interfaces therewith and mounts thereto by an attachment or connection plug **165**. One or more batteries **166** are provided to power the light during use. The light may have control circuitry **167** located in the housing **102**. Battery charger **109c** is located in the power supply **109** for controlling battery recharging and direct powering of the light from wall outlet power when the batteries are low. The power supply **109** has an AC plug **109d**.

A unique advantage of some of the light systems depicted herein is that most or all components of the light system, including the light source, batteries, control circuitry and user interface, are conveniently located in or on a handpiece. This results in a very portable, yet compact and easy to use light system. Only when the batteries are being charged would the user need to have a cord attached to the light system or even be in the vicinity of AC power. In the case of a battery-less light system, the batteries would be omitted and the light system would be connected to a power source by an electrical cord. It would also be possible for the light system to be operated using power from a battery charger when the battery pack is being charged or when no batteries are being used.

FIG. 3 depicts an AC-powered light that uses a single light emitting diode chip as a light source. FIG. 4 depicts a cross section of the light of FIG. 3. Referring to these figures, a light system **301** is depicted. The light system **301** includes a handpiece or wand **302**, cabling **303**, and a power supply **304** with an AC plug **304a**. Light control circuitry **304b** may be located within the power supply **304** and is remote from the wand **302** in order to keep the wand compact and light weight. The handpiece or wand **302** has minimum size, weight and componentry for convenience of use. The handpiece **302** includes a housing **305**, an on/off switch or light output control **306**, an integral light source module **307**, and a device **309** which may be a light shield, light reflective cone or focus lens. The handpiece **302** receives electrical power from cabling **303**. A cable strain relief device **308** may be provided. A timer **310** may be provided with timer adjustment buttons **311** and **312** in order to control timed duration of light output from the light. All control circuitry **304b** is located in a module remote from the handpiece **302**.

Referring to the cross section of FIG. 4, it can be seen that the heat sink **401** may be configured as an elongate device



with a planar mounting platform on its distal end for mounting chips or chip modules thereto. The heat sink has a longitudinal axis, and the light emitting semiconductor chip(s) may be oriented at an angle with the longitudinal axis of the heat sink from about 45 to about 135 degrees. In some lights, the chips may be oriented to emit light at an angle with the heat sink longitudinal axis of 70 to 110 degrees, 80 to 100 degrees, or about 90 degrees. The heat sink distal end may be curved as desired to position a light emitting semiconductor device **401** thereon to be positioned in a location for convenient use. The semiconductor device **402** may be covered with a protective window, dome or focus lens **403**. The heat sink may occupy less than 50% of the length of the wand, more than 50% of the length of the wand, 60% of the length of the wand, 70% of the length of the wand, 80% of the length of the wand, 90% of the length of the wand, or up to 100% of the length of the wand. Electrical wire **404** provides power to the light emitting semiconductor device **402**. Insulation means or insulators **405** such as rubber insulators or insulation tape separate the heat sink **401** from the casing **305** and provide for airspace or an air jacket **406** therebetween for ventilation and heat dissipation. The insulators may be of any suitable material that will provide spacing and distance between the heat sink and the casing or housing to form an air jacket therebetween and permit air circulation, ventilation and heat dissipation. The insulators could be rubber, silicone, plastic or other materials. The light housing may have one or more vents to permit or encourage air to travel from outside the housing into the air jacket, and/or to permit or encourage air from the air jacket to travel outside of the housing. Air exchange can assist in cooling functions. The air jacket can assist in avoiding a buildup of heat in the handpiece, wand or housing that could cause user discomfort.

FIG. 5 depicts a battery-powered light **501** that uses two light emitting diode chips as a light source. FIG. 6 depicts a cross-section of the light **501** of FIG. 5. The light **501** includes a housing or casing **502** for containing and protecting the light components. A series of vents **503** are provided in the housing **502** to permit heat to escape therefrom and to permit air circulation therein. At the distal end of the housing **502**, a light module **504** is provided. The light module **504** may include an angled tip and may be removable and replaceable with other light modules of differing characteristics as desired. A light shield, light reflective cone or focus lens **505** is provided at the distal end of the light module **504**. At the proximal end of the light **501**, a handle **506** is provided for grasping the light. An on-off switch or trigger **507** is provided on the distal side of the light handle **506** for effecting light emission. On the proximal side of the light handle **506**, a main switch **507** for powering up the light **501** is located. A timer **509** with timer adjustment buttons **510** and **511** is provided to time the duration of light output. Indicator lights **512** and **513** are provided to indicate low battery and battery charging. A battery charger module **520** is provided with a power supply **521**, cable **522** and plug **523**. The plug fits into receptacle **601** for charging the battery **602** of the light **501**.

Referring to FIG. 6, light module **504** includes a casing **603** that contains an elongate heat sink **604** that is separated from the casing **603** by insulators **605** to form a ventilating and heat-dissipating air space **606** therebetween. Heat sink **604** may include a thermoelectric cooler material **608** thereon for enhanced heat dissipation. Electrical wires **607** power a pair of light emitting semiconductor devices or modules **609a** and **609b**. The semiconductor devices **609a** and **609b** are mounted on the heat sink **604** at a mounting

receptacle **611** that has two adjacent angled planes oriented to cause the light output beams from the semiconductor devices **609a** and **609b** to overlap to provide an overlapped and enhanced intensity light footprint **610**. The mounting planes are oriented at an angle of from about 10 to about 180 degrees with respect to each other. The light **501** also includes a timer **509** with timer control buttons **621** and **622**, and electronic control circuitry **623**. A battery pack **602** is located inside casing **502** to provide operating power. The light module **504** is connected to housing **502** using an electrical plug **624**. The light module **504** can therefore be unplugged and replaced with another light module of different power characteristics or which emits a different wavelength of light for different usage applications.

FIG. 7 depicts an AC-powered light **701** that uses two light emitting diode chips as a light source. FIG. 8 depicts a cross-section of the light **701** of FIG. 7. The light system **701** includes a handpiece or wand **702**, cabling **703**, and a power supply **704** with an AC plug **704a**. Control circuitry **704b** is located within the power supply **704** and is remote from the wand **702** in order to keep the wand compact and light weight. The handpiece or wand **702** has minimum size, weight and componentry for convenience of use. The handpiece **702** includes a housing **705**, an on/off switch or light output control **706**, an integral light source module **707**, and a light shield **709**. The handpiece **702** receives electrical power from cabling **703**. A cable strain relief device **708** may be provided. A timer **710** may be provided with timer adjustment buttons **711** and **712** in order to control timed duration of light output from the light. All control circuitry **704b** is located in a module remote from the handpiece **702**. Referring to the cross section of FIG. 8, it can be seen that the heat sink **801** may be configured as an elongate device with a longitudinal axis shared with the longitudinal axis of the wand. The light emitting semiconductor chip **802** and **803** are mounted to the heat sink **801** at an acute angle to each other in order to produce an overlapping and enhanced intensity light footprint. The heat sink distal end may be curved as desired to position the light emitting semiconductor devices thereon for convenient use. The semiconductor devices **802** and **803** may be covered by a protective window, dome or focus lens. The heat sink may occupy less than 50% of the length of the wand, more than 50% of the length of the wand, 60% of the length of the wand, 70% of the length of the wand, 80% of the length of the wand, 90% of the length of the wand, or up to 100% of the length of the wand. Electrical wire **804** provides power to the light emitting semiconductor devices **802** and **803**. Insulation means **805** such as rubber insulators or insulation tape separate the heat sink **801** from the casing **705** and provide for airspace **806** therebetween for ventilation and heat dissipation. A connection plug **810** is provided for connecting the power module to the light. Thermoelectric cooler material **820** is optionally provided on the heat sink for enhanced cooling.

FIG. 9 depicts a battery-powered light **901** that uses three light emitting diode chips or modules as a light source. FIG. 10 depicts a cross-section of the light **901** of FIG. 9. The componentry of this light is as generally described previously except for its three light emitting diode light source structure. It uses three light emitting diode chips or chip modules **902a**, **902b** and **902c** arranged in complementary angled configuration so that the light beams emitted by each overlap at a desired distance from the light source to form an overlapped and enhanced intensity light footprint **903**. The arrangement of 3 LED's is described elsewhere in this document.



FIG. 11 depicts an AC-powered light 1101 that uses three light emitting diode chips or modules as a light source. FIG. 12 depicts a cross-section of the light 1101 of FIG. 11. The componentry of this light is as generally described previously except for its three light emitting diode light source structure. It uses three light emitting diode chips or chip modules 1102a, 1102b and 1102c arranged in complementary angled configuration so that the light beams emitted by each overlap at a desired distance from the light source to form an overlapped and enhanced intensity light footprint 1103.

FIG. 13 depicts a battery-powered curing 1301 light that uses a plurality of semiconductor chip modules mounted on a heat sink in a manner that the light they emit is collected by a reflector apparatus and focused by a lens means onto a light transport mechanism, such as a light guide, plastic stack or fiber 1302. FIG. 14 depicts a cross-section of the light 1301 of FIG. 13. Many of the components of this light are as discussed previously for other lights, and that discussion is not repeated here. However, the light source and light transport means are very different from lights discussed above. The light 1301 includes a housing 1303 which has a light transport means 1302 such as a light guide, plastic stack or fiber attached to it. The light transport means 1302 transports light from a light module to a remote location for use. The light transport means 1302 depicted has a curved distal portion 1304 to cause light 1305 to be emitted in a desired direction, such as at a right angle to the longitudinal axis of the light or the light transport means. The light transport means may be removable and replaceable with light guides of different lengths and configurations. A gross or secondary heat sink 1405 is provided for heat removal from the system. The secondary heat sink 1405 has a proximal side on which a thermoelectric material layer 1406 may be placed to enhance heat removal ability. Optionally, a fan 1407 may be provided to improve heat removal efficiency, and vents may be provided in the housing to encourage air circulation. The secondary heat sink 1405 may have mounted directly or indirectly to it a plurality of semiconductor light emitting chips or chip modules 1409. Those chips 1409 may be mounted to a primary heat sink such as 1410. Light emitted by the chips 1409 will be reflected by a reflector device 1411 such as a mirrored parabolic reflector to an optional lens or focusing device 1412 which focuses a generally coherent light beam onto the light transport means 1302. The reflector may be of a desired shape for directing light, such as frusto-conical, parabolic or otherwise. If the light emitting devices are oriented so that the light which they emit is substantially directed toward the distal end of the light, the reflector may be omitted. A battery pack 1415 and control circuitry 1413 are provided.

FIG. 15 depicts an alternative configuration of the light of FIG. 13. The light 1501 has no light transport mechanism and instead has a light exit tube 1502 that has a distal end with a mirror or reflector 1504 which can reflect a generally coherent light beam 1503 to a light exit 1505 in a desired direction for use, such as at a generally right angle to the longitudinal axis of the light module or the light.

FIG. 16a depicts a light light 1601 that has a light source and control module 1602 remotely located from a handpiece 1603 connected by a connection means 1604 that includes an optically conductive cable and electrical wires for electrical connection. FIG. 16b depicts a cross section of the light of FIG. 16a. The light source and control module 1602 includes a housing 1610 with optional air vents thereon, electronic control circuitry 1611, an electrical cord with power plug 1612, a cooling fan 1613 for air circulation and

heat dissipation, a heat sink 1615 which may be appropriately shaped to accept light emitting semiconductor devices on its distal side, such as having a concave hemispherical or parabolic portion, and having a thermoelectric cooler 1616 on its proximal side for enhanced heat dissipation. A plurality of light emitting semiconductor devices such as LED chip modules 1618 are mounted to the heat sink distal side so that they emit light into an optical system such as a focus lens 1619 which places a generally coherent light beam onto the optically conductive cable where it is transported to a distant handpiece 1603 that includes a housing 1651, light exit 1650 for permitting light to be delivered to a light-activated material to be cured, and various controls such as light on/off control 1660, timer display 1663, and timer adjustment buttons 1661 and 1662. The distal end of the handpiece housing 1670 may be angled from the longitudinal axis of the handpiece in for convenience of light application to a light-activated material. The remote light source employed by the light in FIGS. 16a and 16b permit a larger and very high power light source, such as one which provides 800 mw/cm<sup>2</sup> to 2000 mw/cm<sup>2</sup> output from the handpiece.

As desired in various lights, the light source may be a single LED chip, single LED chip array, an array of LED chips, a single diode laser chip, an array of diode laser chips, a VCSEL chip or array, or one or more LED or diode laser modules. The wavelength of light emitted from the semiconductor light source can be any desired wavelength or combination of different wavelength, depending on the sensitivity of the photoinitiator(s) in the light-activated material to be cured. Any of the semiconductor and heat sink arrangements described herein may be used to construct desired lights.

Referring to FIG. 17a, a light emitting diode (“LED”) chip 1701 is depicted in which the LED structure 1702 has been grown on top of or on one side of an insulative substrate 1703. Electrodes 1704a and 1704b are provided to power the LED. In such a structure, all electrodes will be located on the top surface of the LED. Light is emitted from all sides of the LED as depicted.

A similar LED chip 1710 with a conductive substrate 1711 and accompanying LED structure 1712 and electrodes 1713 and 1714 is depicted in FIG. 17b.

FIG. 18a depicts an example of epitaxial layer configuration 1801 for an LED with an insulative substrate used in lights depicted herein. The LED includes an electrically insulative substrate such as sapphire 1802. The substrate serves as a carrier, pad or platform on which to grow the chip’s epitaxial layers. The first layer placed on the substrate 1802 is a buffer layer 1803, in this case a GaN buffer layer. Use of a buffer layer reduces defects in the chip which would otherwise arise due to differences in material properties between the epitaxial layers and the substrate. Then a contact layer 1804, such as n-GaN, is provided. A cladding layer 1805 such as n-AlGaN Sub is then provided. Then an active layer 1806 is provided, such as InGaN multiple quantum wells. The active layer is where electrons jump from a conduction band to valance and emit energy which converts to light. On the active layer 1806, another cladding layer 1807, such as p-AlGaN is provided that also serves to confine electrons. A contact layer 1808 such as p+ GaN is provided that is doped for Ohmic contact. The contact layer 1808 has a positive electrode 1809 mounted on it. The contact layer 1804 has a negative electrode 1810.

FIG. 18b depicts epitaxial layer configuration 1850 for an LED with a conductive substrate. The LED includes an electrically conductive substrate such as SiC 1852 that has



an electrode **1851** on it. The substrate serves as a carrier, pad or platform on which to grow the chip's epitaxial layers, and as a negative electrode in the chip. The first layer placed on the substrate **1852** is a buffer layer **1853**, such as n-GaN. A cladding layer **1854** such as n-AlGaIn is provided followed by an active layer **1855** such as InGaIn with multiple quantum wells. That is followed by a cladding layer **1856** such as p-AlGaIn and finally a contact layer **1857** such as p-GaN that has an electrode **1858** mounted on it.

FIG. **19a** depicts a top view of a single chip array, such as an LED chip array on a single chip **1901** (in contrast with an array of single chips) with a size  $a \times b$  on an insulating substrate. The size of  $a$  and  $b$  may each be greater than 300 micrometers, or may each be greater than 1 millimeter if desired. Semiconductor materials **1904** are located on an electrically insulative substrate (not shown). Positive and negative electrode pads are provided, each in electrical connection with its respective metal electrode strip **1902** and **1903** arranged in a row and column formation (8 columns shown) to create the array and power the chip. This structure enables the LED to emit light of greater power than that which is possible in a non-array traditional chip. The electrode layout of FIG. **19a** is called a 'comb' layout.

FIG. **19b** depicts a top view of an semiconductor chip array, such as an LED chip array, on a single chip **1950** with a size  $a \times b$ , on a conductive substrate. Each of sizes  $a$  and  $b$  may be greater than 300 micrometers, or as desired, each of  $a$  and  $b$  may be greater than 1 millimeter. Semiconductor materials **1952** are located on an electrically conductive substrate (not shown). Positive electrode pads are provided in electrical connection with a metal strip **1951** arranged in an array formation to power the chip. The substrate serves as the negative electrode in this depiction. When LED arrays, or chip arrays (as opposed to an array of chips) such as those depicted are used in a curing light, the light source may be a single chip array, a pair of chip arrays, or multiple chip arrays such as 3 or more chip arrays. The chip arrays may be designed to output any particular desired wavelength and intensity level of light.

Referring to FIG. **20a**, a side view of a surface mount LED chip package **2000** including the LED chip **2001** on a heat sink **2002** is provided. The LED chip depicted has an insulating substrate and is mounted in a well **2004** of the heat sink **2002** by the use of heat conductive and light reflective adhesive **2003**. Light is emitted by the chip in all directions, and light which is emitted toward the adhesive **2003** or the well walls is reflected outward in a useful direction **2020**. The chip is electrically connected via wires **2010a**, **2010b**, **2010c** and **2010d** using intermediary islands **2011** and **2012**. The LED chip is located in a circular well **2004** of the heat sink **2002**. The circular well is formed with sides or walls at about a 45 degree angle or other desired angle (such as from about 170 to about 10 degrees) so that light emitted from the side of the chip will be reflected from the walls of the well in a desired direction as indicated by arrows in the figure. This allows the highest possible light intensity to be obtained using a chip of given size. The well walls may have a light reflective coating to increase efficiency.

Referring to FIG. **20b**, a perspective view of a LED chip array (single chip) chip package **2050** including the chip array **2051** on an insulative substrate in a well **2052** of a heat sink **2053** is depicted.

Referring to FIG. **21a**, a side view of an LED chip module **2100** is provided. An LED chip **2101** with a conductive substrate is mounted in a circular well **2103** of a heat sink **2104** by use of heat conductive light reflective adhesive

**2102**. A negative electrode **2110** is provided on the heat sink. Positive electrical connection is provided by wires **2105** and **2106**, and island **2107**.

Referring to FIG. **21b**, a chip array package **2150** that includes an LED chip array **2151** with a conductive substrate mounted in a well **2152** of a heat sink **2153** with an electrode **2154** and wire connection **2155** is depicted.

FIG. **22a** depicts a side view of a chip package **2200** for a light emitting diode chip array **2201** mounted in a well **2202** of a heat sink **2203** according to the so-called 'flip chip' design, the chip having an insulative substrate. FIG. **22b** depicts a side view of a flip chip **2201** mounted on a flip chip pad **2204**. FIG. **22c** depicts a perspective view of a flip chip pad **2204**. FIG. **22d** depicts a perspective view of the chip package **2200** of FIG. **22a**. Intermediate islands or electrode pads **2201a** and **2210b** are provided on the flip chip pad to ease of electrical connection with the chip. Electrode bumps **2111a** and **2111b** are provided between the chip and the pad for electrical connection. The chip has an electrode **2201b** on top and its epitaxial layers **2201a** facing down toward the pad **2204** and the bottom of the well **2202**. The pad **2204** upper surface is light reflective so that light is reflected from the pad in a useful direction. The pad **2204** may be coated with a light reflective film, such as Au, Al or Ag. In such a package, all of the light emitted from the chip can be reflected back in the light exit direction for highest light output.

FIG. **23** depicts a flip chip package **2301** in which a chip **2302** with a conductive substrate is mounted upside down (electrode up) on a flip chip pad **2303** with light reflective and heat conductive adhesive **2304** in the well of a heat sink. Electrical connection takes advantage of the exposed electrode of the chip **2302**.

Referring to FIG. **24a**, a high power LED package **2401** is depicted using a chip **2402** with an insulative substrate mounted in the well of a heat sink **2403** using heat conductive and light reflective adhesive **2404**. The heat sink is surrounded by a known insulating material **2405** that serves the purpose of protecting electrode and dome connections. The walls and bottom of the well may be polished to be light reflective, or may be covered, plated, painted or bonded with a light-reflective coating such as Al, Au, Ag, Zn, Cu, Pt, chrome, other metals, plating, plastic and others to reflect light and thereby improve light source efficiency. Electrodes and/or connection blocks are provided for electrical connection of the chip. An optical dome or cover **2410** may optionally be provided for the purpose of protecting the chip and its assemblies, and for the purpose of focusing light emitted by the chip. The dome may be made of any of suitable material such as plastic, polycarbonate, epoxy, glass and other suitable materials. The configuration of the well and the dome provide for light emission along an arc of a circle defined by  $\phi$ . The dome **2410** may serve the function of protecting the chip(s) from dirt, moisture, contaminants and mechanical damage. It may also serve the function of focusing light emitted by the chip(s) or otherwise modifying the light beam to a desired configuration or footprint. FIG. **24b** depicts a similar arrangement for a chip package **2450** in which the chip **2454** has a conductive substrate and thus when mounted to the heat sink **2452** can use an electrode **2455** on the heat sink itself for electrical connection. Protective dome **2451** and insulating covering **2453** are provided.

Referring to FIGS. **25a** and **25b**, a chip package **2501** is provided with an array of light emitting semiconductor chips **2504a**, **2504b**, etc. having electrically insulative substrates located in a single well **2502** of a heat sink **2503**. The chips



are mounted by an electrically conductive and heat conductive adhesive **2605**. The chips are electrically connected to each other by wires **2505a**, **2505b**, etc.

Referring to FIGS. **26a** and **26b**, a chip package **2601** is provided that has a heat sink **2602** with a single well **2603** and an array of LED chips **2604a**, **2604b**, etc. in the well **2603**. The chips have electrically conductive substrates and an electrode **2606** is provided on the heat sink.

Referring to FIG. **27a**, a chip package **2701** is depicted with an array of LED chips **2702a**, **2702b**, **2702c**, etc. is depicted, with each chip located in its own individual sub-well **2703a**, **2703b**, **2703c** in a gross well **2704** of a heat sink **2705**. The chips have electrically insulative substrates.

Referring to FIG. **27b**, a chip package **2750** is depicted that has an array of LED chips **2763a**, **2763b**, **2763c** with electrically conductive substrates. Each LED chip is mounted in its own individual sub-well, all located within a gross well **2761** of a heat sink **2762**.

FIGS. **28a** and **28b** depict a chip package **2801** that has a heat sink **2802** with a gross well **2803** and a plurality of sub-wells **2804** therein, each sub-well having a light emitting chip **2805** with a conductive substrate within it. The heat sink **2803** has a negative electrode **2806** for electrical connection.

Referring to FIG. **29a**, an LED chip module **2901** is depicted that has an array of LED chips **2902a**, **2902b**, etc. located in a well **2903** of a heat sink **2904**. Insulative covering **2910** as well as a cover or dome **2911** are provided respectively. The chips of FIG. **29a** have insulative substrates.

Referring to FIG. **29b**, an LED chip module **2950** is depicted that has an array of LED chips **2951a**, **2951b**, etc. located in a well **2955** of a heat sink **2954**. Insulative covering **2960** as well as a cover or dome **2961** are provided respectively. The chips of FIG. **29b** have conductive substrates and an electrode **2959** is provided on the heat sink.

Referring to FIG. **30a**, an LED chip module **3001** is depicted that has an array of LED chips **3002**, with each chip in a sub-well **3003** of a gross well **3006** of a heat sink **3005** and the entire module covered by a protective or focus dome **3012**. The chips have electrically insulative substrates.

Referring to FIG. **30b**, an LED chip module **3050** is depicted that has an array of LED chips **3051**, with each chip in a sub-well **3052** of a gross well **3055** of a heat sink **3054** and the entire module covered by a protective or focus dome **3061**. The chips have electrically conductive substrates and there is an electrode **3056** on the heat sink.

Referring to FIGS. **31a** and **31b**, side and bottom views of a surface mount chip configuration are depicted for mounting a single LED **3100** or LED module (as described previously) to an elongate heat sink **3101**. Electrically conductive wires **3102a** and **3102b** and electrodes **3103a** and **3103b** are provided for powering the LED. The LED is mounted on a platform **3104** formed on the heat sink distal end. Mounting is achieved by use of light reflective and heat conductive adhesive **3105**. A cover or focus dome **3106** is provided over the LED. The heat sink has a longitudinal axis, and the LED is mounted so that the average beam of light that it emits is generally at a 45 to 135 degree angle with that axis, and in some instances at a right angle to it.

FIGS. **32a** and **32b** depict side and bottom views of an elongate heat sink **3201** having two light emitting semiconductor chips or modules **3202** and **3203** mounted on mounting platforms **3204a** and **3204b** using adhesive **3205a** and **3205b** (such as heat conductive or light reflective adhesive). The chips are mounted on the heat sink in an angled orientation with respect to each other in order to present

overlapping light beams for an enhanced density light footprint **3204**. The angle of orientation of the chips is depicted as  $\theta$  which can be from zero to 180 degrees, or from 30 to 150 degrees, or from 45 to 135 degrees, or from 70 to 110 degrees, or from 80 to 100 degrees or about 90 degrees, as desired. The chips are offset from each other by a desired distance 'a', which can range from zero to any desired distance. Wires and electrodes are provided to power the LED's. An optional thermoelectric cooler **3208** may be provided to enhance heat removal.

FIG. **33a** depicts a cross-sectional side view of a light module that uses three light emitting chips or chip modules. FIG. **33b** depicts a bottom view of the same. FIG. **33c** depicts a bottom view of the heat sink and mounting platform arrangement. FIG. **33d** depicts a side view of the heat sink and mounting platform arrangement. An elongate heat sink **3301** is provided having three light emitting semiconductor chips or modules **3302**, **3303**, and **3304** mounted on mounting platforms in an angled orientation with respect to each other in order to present overlapping light beams for an enhanced density light footprint **3306**. The mounting platforms depicted are generally planar and are arranged to present the densest useful light footprint. The modules may each include their own primary heat sink. The modules or chips may be mounted to the elongate heat sink using a heat conductive or light reflective adhesive as desired. Electrical wires and electrodes are used to power the chips or modules. An optional thermoelectric cooler **3308** may be provided. The mounting platforms **3305a**, **3305b** and **3305c** can be seen more clearly in FIGS. **33c** and **33d**. The mounting platforms depicted are arranged in circular fashion at an angular offset  $\theta$  with respect to each other, which in this case is 120 degrees. More mounting platforms could be used, and any desired arrangement of the mounting platforms could be accommodated. In FIG. **33d** it can be seen that the mounting platforms **3305a**, **3305b** and **3305c** are arranged at an angle  $\phi$  with the longitudinal axis of the heat sink **3301**. The angle  $\phi$  can be from 0 to 90 degrees, from 10 to 80 degrees, from 20 to 70 degrees, from 30 to 60 degrees, from 40 to 50 degrees, or about 45 degrees as desired to generate the densest usable light footprint.

FIG. **34a** depicts a light shield **3401** which may be used in conjunction with lights depicted herein to shield human eyes from light emitting by the light. The light shield includes an orifice **3403** through which light from a light may pass, the receptacle **3403** being formed by the light shield body **3402**. A flare **3404** of the shield performs most of the protective function.

FIG. **34b** depicts a focus lens **3402** which may be used to focus light emitted by lights depicted herein in order to present a denser light footprint. The focus lens has an outer periphery **3405**, a light entrance side **3506** and a light exit **3507**. The focus lens may be designed according to known optical principles to focus light output from chips which may not be in an optimal pattern for use in curing.

FIG. **34c** depicts a reflection cone **3408** in conjunction with LED module **3409**, which is mounted on a heat sink **3910** by using heat conductive adhesive **3411**. One or more connection wires **3412** may be provided to power the LED module **3409**. The purpose of the light reflective cone is to re-shape the light beam from the LED module to create a light footprint of desired size and density. The inner wall of the cone **3408** may be coated with a highly reflective material, such as the reflective materials mentioned elsewhere in this document. The light beam from the LED module will change its path and configuration due to being reflected by the cone **3408**.



A detailed depiction of the light reflective cone **3408** is provided in FIG. **34d**, which illustrates a cross-sectional view of the cone. An opening with an appropriate diameter "a" is provided at the proximal side of the cone for fitting to a light module of a light. The diameter "a" is chosen as an appropriate size for permitting light to enter therein. The cone has a total length "b". Adjacent light entrance at "a", a cylindrical portion of the cone is provided having a longitudinal length "c". Following cylindrical portion "c", there is a frusto-conical section of the cone interior having a length "b" minus "c". A light exit is provided at the end of the cone opposite the light inlet. The light exit has a diameter "d", where in many lights, "d" will be smaller than "a". The exterior diameter of the cone at its point of attachment to a light module is "e", where "e" is greater than "a". As desired, the various dimensions of the cone as well as its basic geometry (such as conical, frusto-conical, cylindrical, parabolic, etc.) are selected to achieve a desired light footprint size and density. At least some portion of the interior surfaces of the reflective cone may have the ability to reflect light to aid in increasing the density of a light footprint. Appropriate reflective surfaces are mentioned elsewhere herein. Example dimensions of the various portions of the reflective cone in one light are as follow: a=from about 5 mm to about 8 mm; b=from about 5 mm to about 8 mm; c=from about 2 mm to about 3 mm; d=from about 4 mm to about 6 mm; e=from about 8 mm to about 10 mm. Actual structure and dimensions of a reflective cone or reflective attachment or light exit for a light may vary depending on product type and application and design choice.

FIG. **35** depicts a logic diagram **3501** of circuitry that may be used by AC-powered versions of the invented lights. AC power input **3502** is provided to a power switch source **3503** which outputs DC power to a main switch **3504**. Main switch **3504** powers the control circuit **3505** and the optional TE cooler **3506** if so equipped. Main switch **3504** also provides a constant current source **3507** for the timer **3508**, timer setup **3511**, timer activation switch **3572** and optional light output beeper **3513**. Constant current source **3507** also powers the light source **3509** to accomplish light output **3510**.

Referring to FIG. **36**, a logic diagram **3601** of circuitry that may be used by battery-powered versions of the invented lights is depicted. AC power input **3602** is provided to a power switch source **3603** which outputs DC power to a battery charge unit **3604** that charges battery **3605**. The battery **3605** powers main switch **3607**. Main switch **3607** powers the control circuit **3608** that controls the optional TE cooler **3610** and the fan **3609**. Main switch **3607** also provides a constant current source **3611** for the timer **3613**, timer setup **3614**, timer activation switch **3615** and optional light output beeper **3616**. Constant current source **3611** also powers the light source **3612** to accomplish light output. An electrical voltage booster **3617** may be provided to increase the voltage from the battery to meet electrical requirements of the light source.

Referring to FIG. **37**, a graph of electrical current input I to the light emitting semiconductor chip(s) of the light versus time in a pulsed power input scheme is depicted. FIG. **38** depicts a graph of total light intensity output versus time in order to permit the reader to compare light intensity output when a current input pulsing scheme such as that of FIG. **37** is used to a traditional continuous wave current input approach which generates a heat effect is used. A pulsed current input scheme may be used in order to enhance light power output from the chip(s) and in order to avoid light intensity reduction due to the heat effect. It has been

found that when operated in continuous wave mode, the heat effect or heat buildup in the light emitting semiconductor chips will cause a decrease in light output intensity over time, until a stabilized light output yield is reached at a point in time. In contrast, when current input to the semiconductor light source is pulsed, a greater even level of light power output with greater intensity is achieved. Laboratory experiments have shown this increase "d" to be more than 20% in lights, providing significantly increased light yield and stable light intensity output in exchange for a simple control modification. Each of the square waves in FIG. **37** is a pulse of current input to the semiconductor light source, measured by "a=duration", "b=rest period", and "c=current input level (amps.)". These criteria can be adjusted depending on the curing environment, or pulsed current input to the light source could be omitted in favor of continuous wave current input. It has also been found that pulsed power output from the light (not shown in the figures) may be desirable in some circumstances. Pulsed power output from the light can avoid overloading photoinitiators in the material to be cured with photons, and permitting them to initiate polymerization of a light-activated material in a stable fashion.

Referring to FIG. **39**, a graph showing the spectral output of a light with numerous chips, the chips having differing peak spectral outputs, is provided. Some light-activated materials, such as dental composites may include more than one photoinitiator. The photoinitiators may be sensitive to light of different wavelengths. Even though light emitted by single semiconductor chip can cover many photoinitiators, a single semiconductor chip may not provide broad enough spectral output to cover the full range of possible photoinitiators that may be present in a particular light-activated material. Referring to previous figures, it is possible to construct a curing light that has numerous light-emitting semiconductor chips, at least several of which have differing spectral outputs, such as is depicted in FIG. **39**. For example, LED1 could peak at about 325 nm, while LED2 peaks at about 350 nm, etc. to LED n which peaks at 575 nm. Of course many other configurations and spectral outputs are possible depending on the particular use of the light. The arrangement of the light emitting semiconductor chips can be varied according to the light beam pattern needed.

Depending on number and type of light emitting semiconductor chips used, per FIG. **39**, an overall spectrum profile pattern, such as Profile 1, Profile 2, and Profile n of FIG. **40** can be achieved. These particular spectral profiles are provided by way of example only. On the spectrum Profile n, there are two cutoff wavelengths  $\lambda_1$  and  $\lambda_2$ .  $\lambda_1$  and  $\lambda_2$  will be selected to be the desired wavelength range for a particular class or set of light-activated materials for which the light may be used, and the light will be able to activate light-activated materials sensitive to light between  $\lambda_1$  and  $\lambda_2$ . For example, a light source with  $\lambda_1=400$  nm and  $\lambda_2=460$  nm might provide an appropriate light spectra for activating current dental materials. The spectrum profile has two intensities relative to cut off wavelength,  $I_1$  and  $I_2$ . The value of  $I_1$  and  $I_2$  can be  $I_1>I_2$ ,  $I_1<I_2$  or  $I_1=I_2$ , as desired. The spectrum profile between  $I_1$  and  $I_2$  can be linear, parabolic and others, as desired.

If desired, a curing light can be constructed per FIGS. **39** and **40** in which the peak spectral output of most or each chip is in the range of between 200 and 455 nanometers, so that  $\lambda_1 \geq 200$  nm and  $\lambda_2 \leq 455$  nm. Another variation would place  $\lambda_1 \geq 300$  nm and  $\lambda_2 \leq 455$  nm. Another variation would place  $\lambda_1 \geq 350$  nm and  $\lambda_2 \leq 480$  nm. The starting and ending wavelengths of the profile can be varied, and the



peak output of each chip can be varied as well. Each chip can be of a different wavelength, or more than one chip can be of the same wavelength. Light intensity output from each chip can be as desired, such as 40 mW or more, and in some configurations intensity  $I_1$  and  $I_2$  will both equal or exceed 40 mW. There is no upper limit for light intensity other than ordinary engineering constraints.

Heat sinks are often a combination of two different kinds of materials, the first with a low thermal expansion rate and the second with high thermal conductivity. Monolithic heat sinks may be used as well. Examples of some heat sink materials which may be used in lights depicted herein include copper, aluminum, silver, magnesium, steel, silicon carbide, boron nitride, tungsten, molybdenum, cobalt, chrome, Si,  $\text{SiO}_2$ , SiC, AlSi, AlSiC, natural diamond, monocrystalline diamond, polycrystalline diamond, polycrystalline diamond compacts, diamond deposited through chemical vapor deposition and diamond deposited through physical vapor deposition, and composite materials or compounds. Any materials with adequate heat conductance and/or dissipation properties can be used. If desired, a heat sink may have fins or other surface modifications or structures to increase surface area and enhance heat dissipation.

Examples of heat conductive and/or electrically insulative adhesives which may be used are silver based epoxy, other epoxies, and other adhesives with a heat conductive quality and/or electrically insulative quality. In order to perform a heat conductive function, it is important that the adhesive possess the following characteristics: (i) strong bonding between the materials being bonded, (ii) adequate heat conductance, (iii) electrically insulative or electrically conductive if desired (or both), and (iv) light reflectivity if desired, or any combination of the above. Examples of light reflective adhesives which may be used include silver and aluminum based epoxy. One example heat conductive and electrically insulative adhesive includes a mixture of a primer and an activator. In this example, the primer may contain one or more heat conductive agents such as aluminum oxide (about 20–60%) and/or aluminum hydroxide (about 15–50%). The primer may also contain one or more bonding agents such as polyurethane methacrylate (about 8–15%), and/or hydroxyalkyl methacrylate (about 8–15%). An activator may be mixed with the primer to form an adhesive. The activator may include any desired catalyst, for example n-heptane (about 5–50%), aldehyde-aniline condensate (about 30–35%), isopropyl alcohol (about 15–20%), and an organocopper compound (about 0.01 to 0.1%). Adhesives such as described herein can be used to mount a chip to a primary heat sink, or to mount a primary heat sink to a secondary heat sink, or both.

Examples of substrates on which the semiconductors used in the lights depicted herein may be grown include Si, GaAs, GaN, ZnS, ZnSe, InP,  $\text{Al}_2\text{O}_3$ , SiC, GaSb, InAs and others. Both electrically insulative and electrically conductive substrates may be used.

Materials which may be used in a thermoelectric cooler in lights depicted herein include  $\text{Bi}_2\text{Te}_3$ , PbTe, SiGe,  $\text{BeO}_2$ , BiTeSe, BiTeSb,  $\text{AlO}_3$ , AlN, BaN and others.

The semiconductor light source of a light should emit light of a wavelength suitable to activate the desired light-activated material. This may be achieved by using a semiconductor light source that emits a wavelength of light to which the light-activated material is sensitive, or emitting a shorter wavelength of light at a higher power level. Laboratory testing shows that using a wavelength of light that is

longer than the wavelength to which the light-activated material is sensitive is often not effective in activating the light-activated material.

Heat sinks used in the lights can be of a variety of shapes and dimensions, such as those depicted in the drawings or any others which are useful for the structure of the particular light source being constructed. It should be noted that particular advantage has been found when attaching the semiconductor light source to a small primary heat sink, and then the small primary heat sink is attached to an elongate secondary heat sink to draw heat away from the semiconductor and away from the patient's mouth.

While the present lights have been described and illustrated in conjunction with a number of specific configurations, those skilled in the art will appreciate that variations and modifications may be made without departing from the principles herein illustrated, described, and claimed. The present invention, as defined by the appended claims, may be embodied in other specific forms without departing from its spirit or essential characteristics. The configurations of lights described herein are to be considered in all respects as only illustrative, and not restrictive. All changes which come within the meaning and range of equivalency of the claims are to be embraced within their scope.

What is claimed is:

1. A light for activating a light-activated material comprising:
  - a light module capable of emitting light useful in activating a light-activated material,
  - a primary heat sink in said light module,
  - at least one well in said primary heat sink,
  - said well having a wall,
  - said heat sink having thermal conductance qualities,
  - a plurality of light emitting chips,
  - said chips being mounted to said heat sink,
  - at least one of said chips being mounted in said well,
  - an optical cover,
  - said cover covering said chip mounted in said well in order to provide protection for said chip,
  - at least some of said light emitting chips being capable of emitting light of a wavelength that is useful in activating a light activated material,
  - the actual number of said plurality of light emitting chips being a positive integer "n", where n is greater than or equal to 2,
  - each of said light emitting chips emitting light of a certain peak wavelength  $\lambda_i$ , where "i" is an integer between 1 and n,
  - a first of said light emitting chips having the lowest peak wavelength light emission of said plurality of light emitting chips, said lowest peak wavelength light emission being referred to as " $\lambda_1$ ",
  - a last of said light emitting chips having the highest peak wavelength light emission of said plurality of light emitting chips, said highest peak wavelength light emission being referred to as " $\lambda_n$ ",
  - the wavelength of  $\lambda_1$  being less than  $\lambda_n$ ,
  - each of said light emitting chips peak wavelengths  $\lambda_i$  being greater than  $\lambda_1$  and less than  $\lambda_n$ ,
  - $\lambda_1$  and  $\lambda_n$  serving to define the lower and upper wavelength limits output by said plurality of light emitting chips,
  - said peak wavelength limits  $\lambda_1$  and  $\lambda_n$  being selected to define a wide light spectrum profile capable of activating various light-activated materials having sensitivities to various light wavelengths in the range of  $\lambda_1 \dots \lambda_n$ ,



19

- each of said light emitting chips emitting light of an intensity  $I_i$ , where "i" is an integer between 1 and n, a first of said light emitting chips having the lowest intensity of light emission of said plurality of light emitting chips, said lowest intensity light emission being referred to as " $I_1$ ",
- a last of said light emitting chips having the highest intensity of light emission of said plurality of light emitting chips, said highest intensity light emission being referred to as " $I_n$ ",
- the intensity of  $I_1$  being less than the intensity of  $I_n$ , and the intensity of light emitted by a particular chip "i" being designated  $I_i$  where  $I_i$  is greater than  $I_1$  and where  $I_i$  is less than  $I_n$ ;
- wherein the intensity of  $I_i$  of at least some of said plurality of light emitting chips is sufficient to cause activation of a light-activated material sensitive to activation by light of the wavelength  $\lambda_i$ .
2. A light for activating a light-activated material as recited in claim 1 further comprising a secondary heat sink, said primary heat sink being affixed to said secondary heat sink, said secondary heat sink serving to draw heat away from said primary heat sink, and said secondary heat sink serving to dissipate heat.
3. A light for activating a light-activated material as recited in claim 1 wherein at least one of said chips has a width dimension of not less than 300 micrometers.
4. A light for activating a light-activated material as recited in claim 1 wherein at least one of said chips has a width dimension of not less than 1 millimeter.
5. A light for activating a light-activated material as recited in claim 1 wherein  $I_i$  for at least one of said plurality of light emitting chips is at least 40 mW/cm<sup>2</sup>.
6. A light for activating a light-activated material as recited in claim 1 wherein  $I_1$  is less than  $I_n$ .
7. A light for activating a light-activated material as recited in claim 1 wherein  $\lambda_1$  is greater than or equal to 200 nm and  $\lambda_n$  is less than or equal to 455 nm.
8. A light for activating a light-activated material as recited in claim 1 wherein  $\lambda_1$  is greater than or equal to 300 nm and  $\lambda_n$  is less than or equal to 460 nm.
9. A light for activating a light-activated material as recited in claim 1 wherein  $\lambda_1$  is greater than or equal to 300 nm and  $\lambda_n$  is less than or equal to 455 nm and wherein  $I_i$  is greater than or equal to 40 mW/cm<sup>2</sup> for said plurality of light emitting chips.
10. A light for activating light-activated materials as recited in claim 1 wherein at least one of said chips is selected from the group consisting of light emitting diode chips, laser chips, light emitting diode chip arrays, diode laser chips, diode laser chip arrays, surface emitting laser chips, edge emitting laser chips, and VCSEL chips.
11. A light for activating a light-activated material as recited in claim 1 wherein said cover is an optical dome.
12. A light for activating a light-activated material as recited in claim 11 wherein said optical dome focuses light emitted by said chip.
13. A light for activating a light-activated material as recited in claim 12 wherein said optical dome includes a material selected from the group consisting of plastic, polycarbonate, epoxy and glass.
14. A light for activating a light-activated material as recited in claim 13 wherein said optical dome provides for light emission along an arc of a circle defined by an angle  $\phi$ .

20

15. A light for activating a light-activated material as recited in claim 14 wherein said optical dome serves to modify light output from said chip into a beam of a desired configuration.
16. A light for activating a light-activated material as recited in claim 1 wherein all of said chips are mounted in a single well.
17. A light for activating a light-activated material as recited in claim 1 wherein each of said chips is mounted in its own individual well.
18. A light for activating a light-activated material comprising:
- a light module capable of emitting light useful in activating a light-activated material,
- a primary heat sink in said light module,
- at least one well in said primary heat sink,
- said well having a light reflective wall,
- said wall serving to reflect light which strikes it,
- said heat sink having thermal conductance qualities,
- a plurality of light emitting chips,
- said chips being mounted to said heat sink,
- at least one of said chips being mounted in said well,
- an optical cover,
- said cover covering said chip mounted in said well in order to provide protection for said chip,
- a secondary heat sink, said primary heat sink being affixed to said secondary heat sink, said secondary heat sink serving to draw heat away from said primary heat sink, and said secondary heat sink serving to dissipate heat,
- at least some of said light emitting chips being capable of emitting light of a wavelength that is useful in activating a light activated material,
- the actual number of said plurality of light emitting chips being a positive integer "n", where n is greater than or equal to 2,
- each of said light emitting chips emitting light of a certain peak wavelength  $\lambda_i$ , where "i" is an integer between 1 and n,
- a first of said light emitting chips having the lowest peak wavelength light emission of said plurality of light emitting chips, said lowest peak wavelength light emission being referred to as " $\lambda_1$ ",
- a last of said light emitting chips having the highest peak wavelength light emission of said plurality of light emitting chips, said highest peak wavelength light emission being referred to as " $\lambda_n$ ",
- the wavelength of  $\lambda_1$  being less than  $\lambda_n$ ,
- each of said light emitting chips peak wavelengths  $\lambda_i$  being greater than  $\lambda_1$  and less than  $\lambda_n$ ,
- $\lambda_1$  and  $\lambda_n$  serving to define the lower and upper wavelength limits output by said plurality of light emitting chips,
- said peak wavelength limits  $\lambda_1$  and  $\lambda_n$  being selected to define a wide light spectrum profile capable of activating various light-activated materials having sensitivities to various light wavelengths in the range of  $\lambda_1 \dots \lambda_n$ ,
- each of said light emitting chips emitting light of an intensity  $I_i$ , where "i" is an integer between 1 and n,
- a first of said light emitting chips having the lowest intensity of light emission of said plurality of light emitting chips, said lowest intensity light emission being referred to as " $I_1$ ",
- a last of said light emitting chips having the highest intensity of light emission of said plurality of light

**21**

emitting chips, said highest intensity light emission  
 being referred to as " $I_n$ ",  
 the intensity of  $I_1$  being less than the intensity of  $I_n$ , and  
 the intensity of light emitted by a particular chip " $i$ " being  
 designated  $I_i$  where  $I_i$  is greater than  $I_1$  and where  $I_i$  is 5  
 less than  $I_n$ ;  
 wherein the intensity of  $I_i$  of at least some of said plurality  
 of light emitting chips is sufficient to cause activation  
 of a light-activated material sensitive to activation by  
 light of the wavelength  $\lambda_i$ ; 10  
 wherein at least one of said chips has a width dimension  
 of not less than 300 micrometers;

**22**

wherein  $I_i$  for at least one of said plurality of light emitting  
 chips is at least 40 mW/cm<sup>2</sup>;  
 wherein  $\lambda_1$  is greater than or equal to 200 nm and  $\lambda_n$  is less  
 than or equal to 460 nm;  
 wherein said cover is an optical dome;  
 wherein said optical dome provides for light emission  
 along an arc of a circle defined by an angle  $\phi$ ; and  
 wherein said optical dome serves to modify light output  
 from said chip into a beam of a desired configuration.

\* \* \* \* \*