



US006976064B2

(12) **United States Patent**  
**Carvey et al.**

(10) **Patent No.:** **US 6,976,064 B2**  
(45) **Date of Patent:** **\*Dec. 13, 2005**

(54) **APPARATUS AND METHODS FOR CONNECTING MODULES USING REMOTE SWITCHING**

4,631,637 A 12/1986 Romania et al.

(Continued)

(75) Inventors: **Philip P. Carvey**, Bedford, MA (US);  
**William J. Dally**, Stanford, CA (US);  
**Larry R. Dennison**, Norwood, MA (US)

(73) Assignee: **Avici Systems, Inc.**, N. Billerica, MA (US)

(\*) Notice: Subject to any disclaimer, the term of this patent is extended or adjusted under 35 U.S.C. 154(b) by 146 days.

This patent is subject to a terminal disclaimer.

(21) Appl. No.: **10/456,121**

(22) Filed: **Jun. 6, 2003**

(65) **Prior Publication Data**

US 2003/0195992 A1 Oct. 16, 2003

**Related U.S. Application Data**

(63) Continuation of application No. 09/765,138, filed on Jan. 18, 2001, now Pat. No. 6,606,656, which is a continuation of application No. 09/083,722, filed on May 22, 1998, now Pat. No. 6,205,532.

(51) **Int. Cl.**<sup>7</sup> ..... **G06F 15/177**

(52) **U.S. Cl.** ..... **709/220; 709/221; 709/239; 361/731; 361/736**

(58) **Field of Search** ..... **709/220, 221, 709/239; 361/731, 736, 788**

(56) **References Cited**

**U.S. PATENT DOCUMENTS**

- 4,118,094 A 10/1978 Key
- 4,340,092 A 7/1982 Chisholm
- 4,371,013 A 2/1983 Camp
- 4,469,388 A 9/1984 Narozny

**OTHER PUBLICATIONS**

Glass, C.J., and Ni, L.M., "The Turn Model for Adaptive Routing," *Proc. 19th Internat. Symposium on Computer Architecture*, 278–287 (May 1992).

Rettberg, R., et al., "Development of a Voice Funnel System: Design Report," Bolt Beranek and Newman, Inc., Report No. 4098, 149 pages (Aug. 1979).

Dally, William, "Network and Processor Architecture for Message-Driven Computers." In *VLSI and Parallel Computation*, Suaya, R., and Birtwistle, G., eds. (San Mateo, CA: Morgan Kaufman), pp. 140–222 (1990).

(Continued)

*Primary Examiner*—Frantz B. Jean

(74) *Attorney, Agent, or Firm*—Hamilton, Brook, Smith & Reynolds, P.C.

(57) **ABSTRACT**

A module connection assembly connects modules in a torus configuration that can be changed remotely. In particular, a single module can be added to or deleted from the configuration by remotely switching from conducting paths that provide end-around electrical paths to conducting paths that provide pass-through electrical paths. The assembly includes two backplanes, a first set of module connectors for electrically connecting modules to one of the backplanes, and a second set of module connectors for electrically connecting modules to the other backplane. The assembly further includes configuration controllers. Each configuration controller selects between end-around electrical paths that electrically connect multiple module connectors of the first set to each other, and pass-through electrical paths that electrically connect module connectors of the first set to module connectors of the second set. Each configuration controller operates as a remotely configurable switch that configures a topology formed by the backplanes and the module connectors. In particular, by adding a single module, the topology can be expanded incrementally.

**9 Claims, 18 Drawing Sheets**

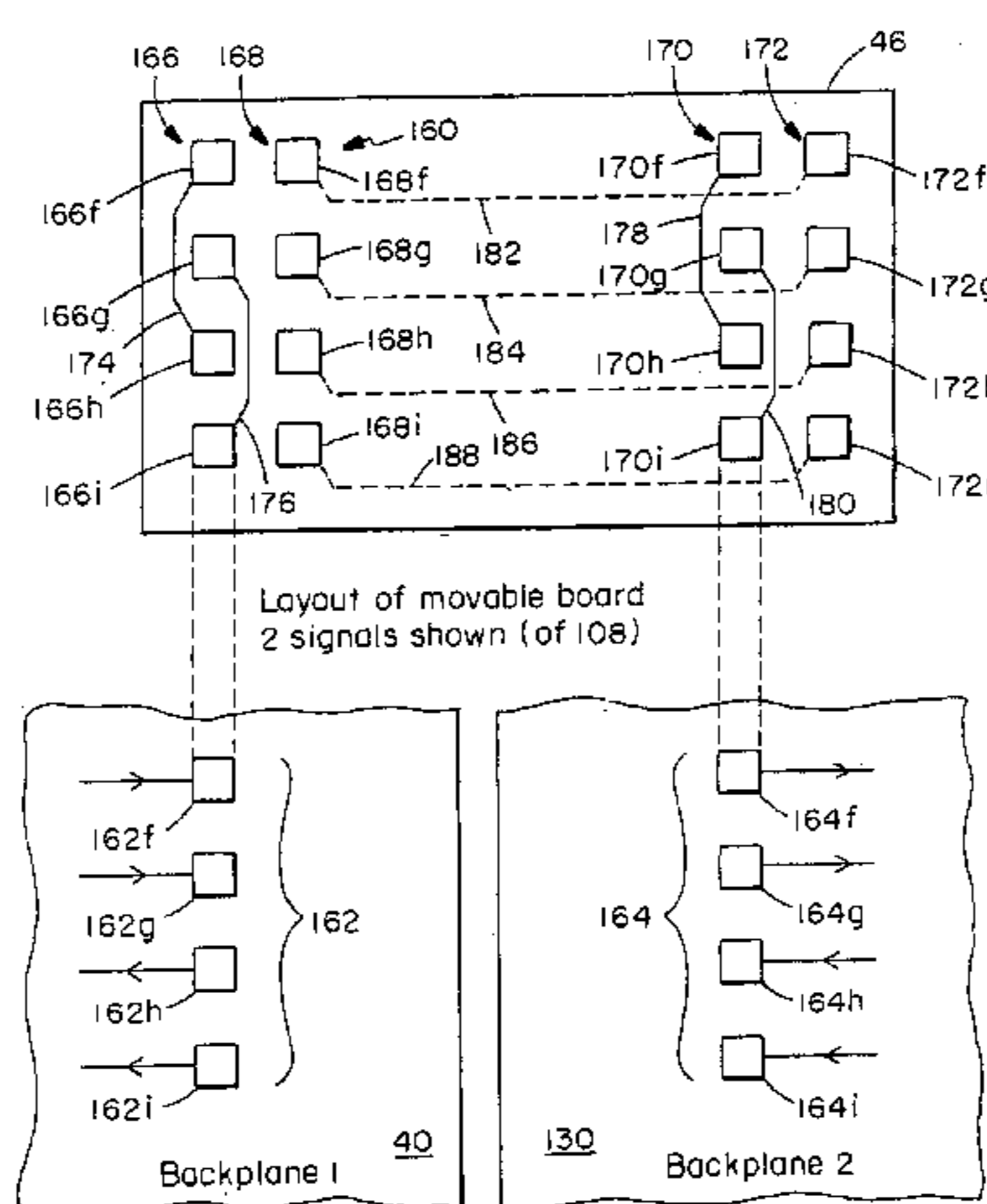

U.S. PATENT DOCUMENTS

4,861,274	A	8/1989	Brune et al.	
4,911,645	A	3/1990	August et al.	
4,933,933	A	6/1990	Dally et al.	
5,088,091	A	2/1992	Schroeder et al.	
5,123,848	A	6/1992	August et al.	
5,134,690	A	7/1992	Samatham	
5,144,691	A	9/1992	August et al.	
5,155,784	A	10/1992	Knott	
5,172,371	A	12/1992	Eng et al.	
5,261,827	A	11/1993	Lenzi et al.	
5,325,270	A	6/1994	Wenger et al.	
5,349,343	A	9/1994	Oliver	
5,352,123	A	10/1994	Sample et al.	
5,408,469	A	4/1995	Opher et al.	
5,425,169	A	6/1995	Steinman et al.	
5,444,701	A	8/1995	Cypher et al.	
5,521,591	A	5/1996	Arora et al.	
5,522,046	A	5/1996	McMillen et al.	
5,530,811	A	6/1996	Benton et al.	
5,530,842	A *	6/1996	Abraham et al. ....	709/221
5,532,856	A	7/1996	Li et al.	
5,533,201	A	7/1996	Benton et al.	
5,581,705	A	12/1996	Passint et al.	
5,583,990	A	12/1996	Birritella et al.	
5,603,044	A *	2/1997	Annapareddy et al. ....	710/301
5,617,577	A	4/1997	Barker et al.	
5,625,780	A	4/1997	Hsieh et al.	
5,646,373	A *	7/1997	Collins et al. ....	174/252
5,649,100	A	7/1997	Ertel et al.	
5,659,716	A	8/1997	Selvidge et al.	
5,659,796	A	8/1997	Thorson et al.	
6,188,675	B1	2/2001	Casper et al.	

OTHER PUBLICATIONS

Dally, William J., "Virtual-Channel Flow Control," *IEEE Transactions on Parallel and Distributed Systems*, 3(2):194-205 (Mar. 1992).

Dally, W.J., and Seitz, C.L., "The torus routing chip," *Distributed Computing*, 1:187-196 (1986).

Jesshope, Chris, "The MP1 Chip and its Application," Dept. of Electronic and Electrical Engineering, Univ. of Surrey, Guildford, Surrey GU2 5XH, UK, 47-54.

Kessler, R.E., and Schwarzmeier, J.L., "CRAY T3D: A New Dimension for Cray Research," *IEEE*, 1063-6390/93, 176-182 (1993).

Dally, William et al., "Deadlock-Free Message Routing in Multiprocessor Interconnection Networks," *IEEE Transactions on Computers*, C-36(5):547-553 (May 1987).

Jesshope, C., and Izu, C., "The MP1 Network Chip," *IEEE*, 1066-6192/92, 338-348 (1992).

Dally, William J., et al., "The Reliable Router: A Reliable and High-Performance Communication Substrate for Parallel Computers," *Proc. of Parallel Computer Routing and Communicationorkshop*, Seattle, WA, 241-255 (May 1994).

Dally, W.J., et al., "Architecture and Implementation of the Reliable Router," *Proc. of Hot Interconnects II*, Stanford, CA, 122-133 (Aug. 11-13, 1994).

Nuth, P.R., and Dally, W.J., "The J-Machine Network," *Proc. of the Internat. Conference on Computer Design: VLSI in Computers and Processors*, Cambridge, MA, 420-423 (Oct. 1992).

Dennison, Larry R., "The Reliable Router: An Architecture for Fault Tolerant Interconnect," doctoral dissertation, Massachusetts Institute of Technology, Cambridge, MA, 444 pages (Jun. 1996).

Stunkel, C.B., et al., "The SP2 High-Performance Switch," *IBM Systems Journal*, vol. 34, No. 2, 19985, pp. 184-204.

\* cited by examiner

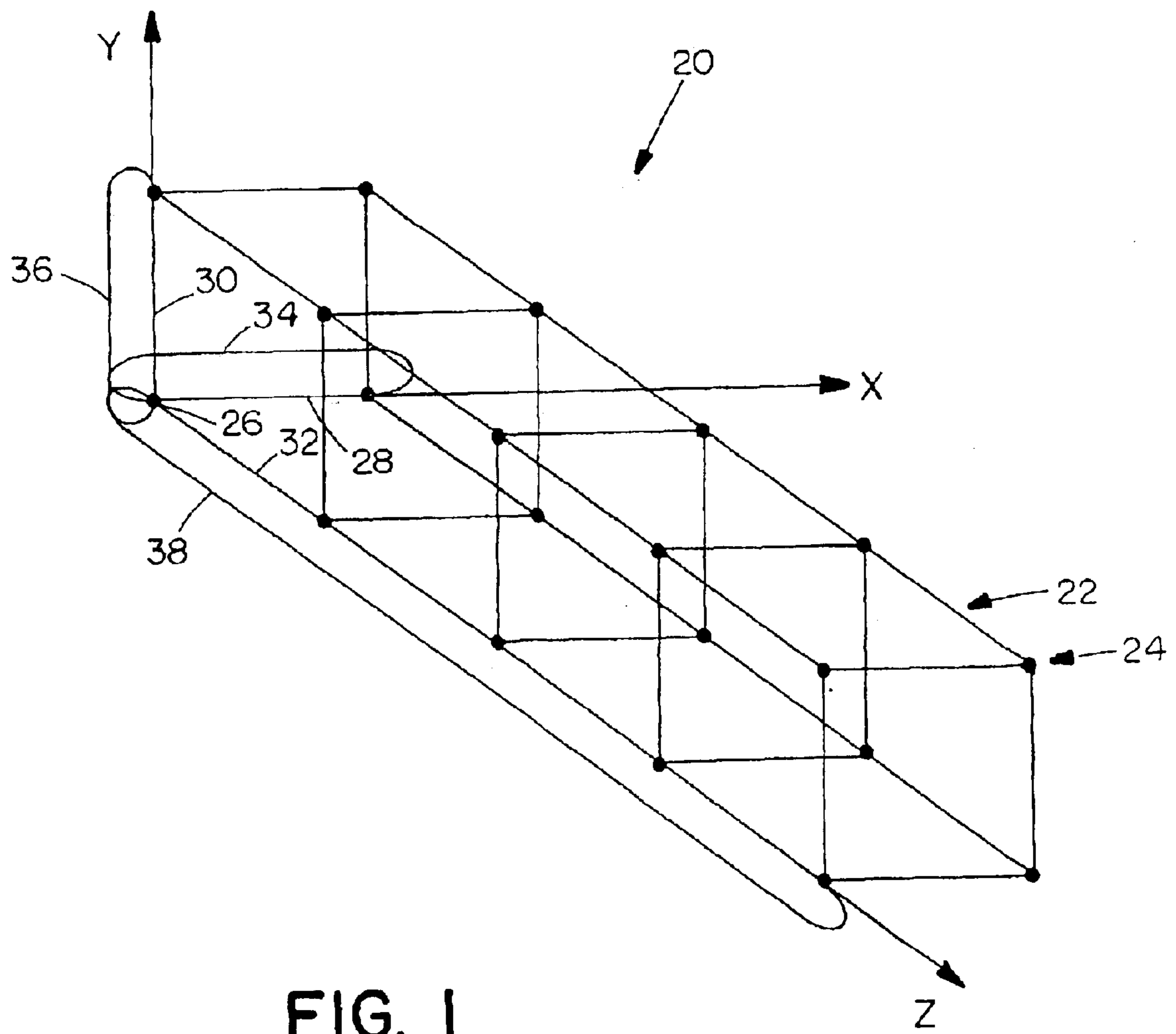

FIG. 1

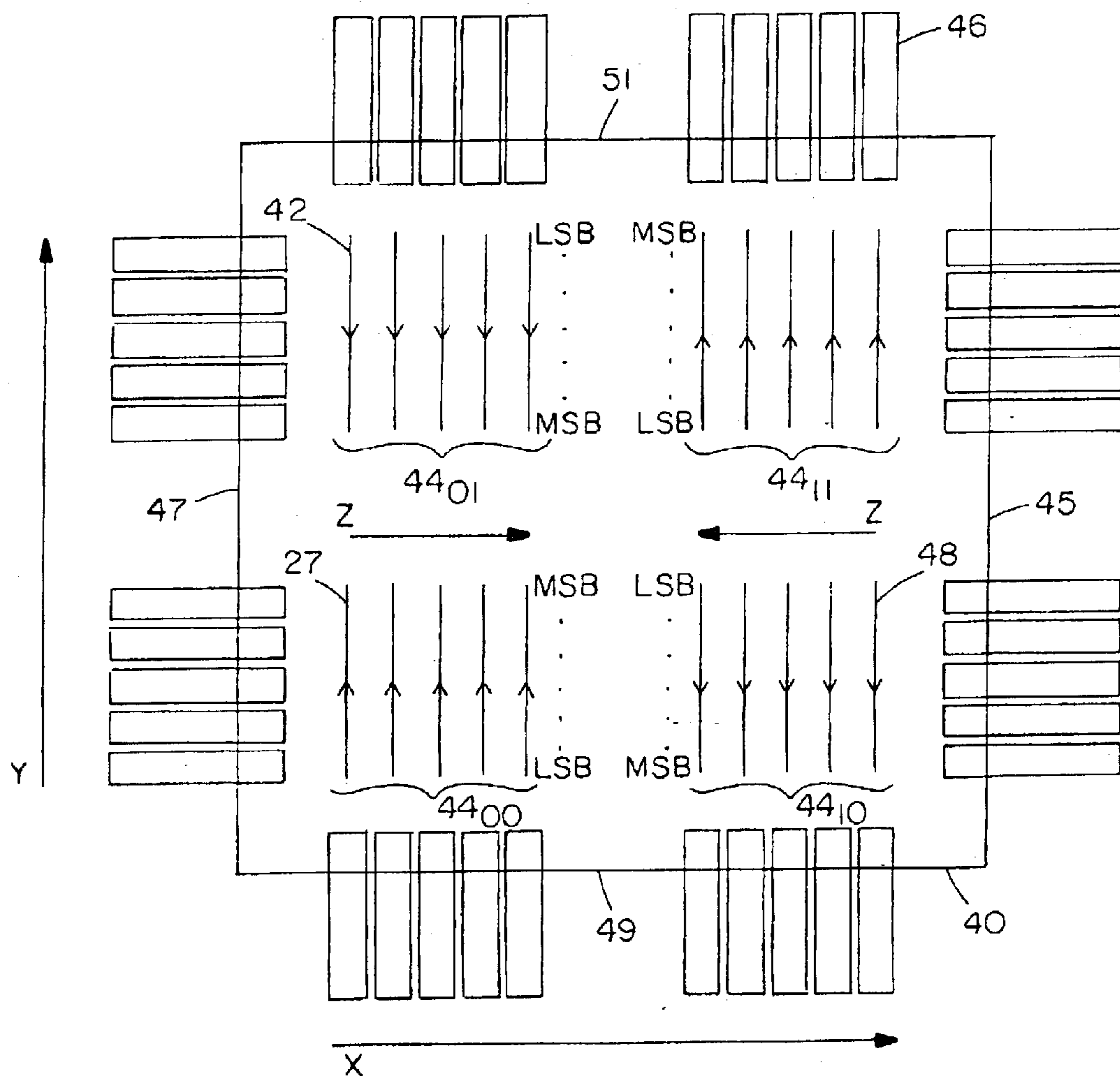

FIG. 2



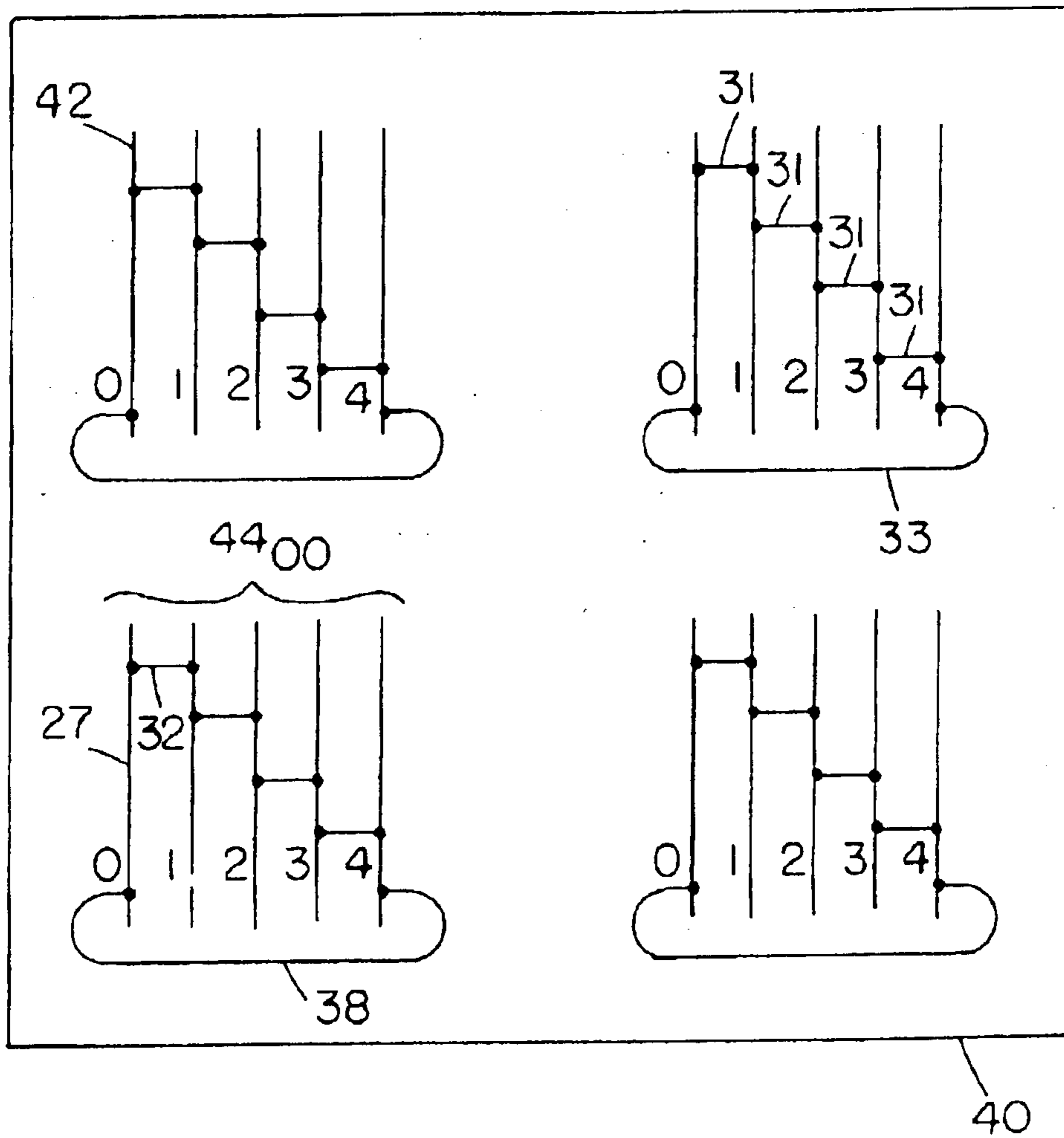

FIG. 3

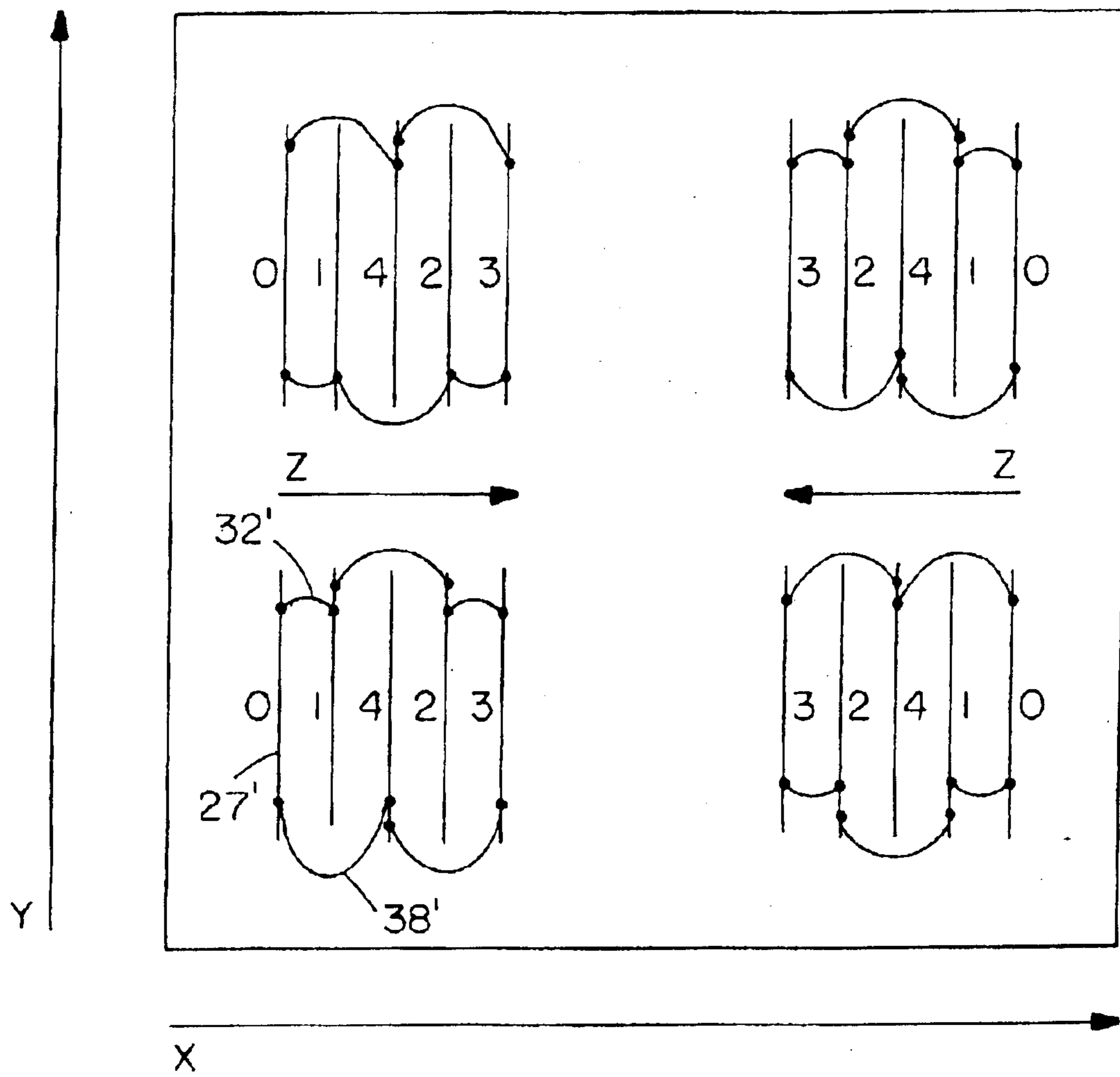

FIG. 4

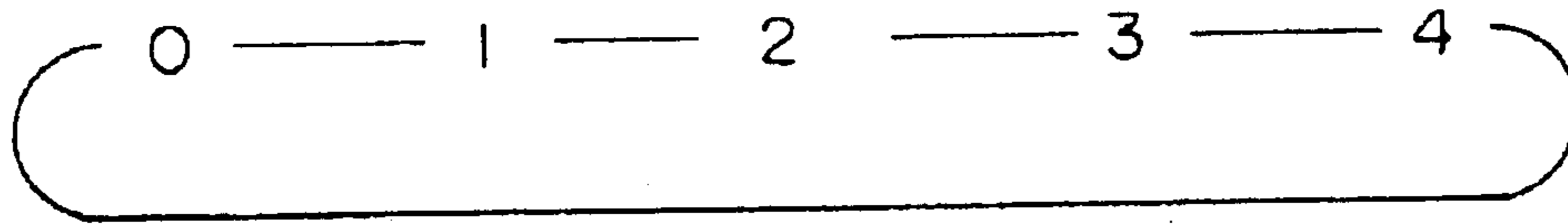

FIG. 5A

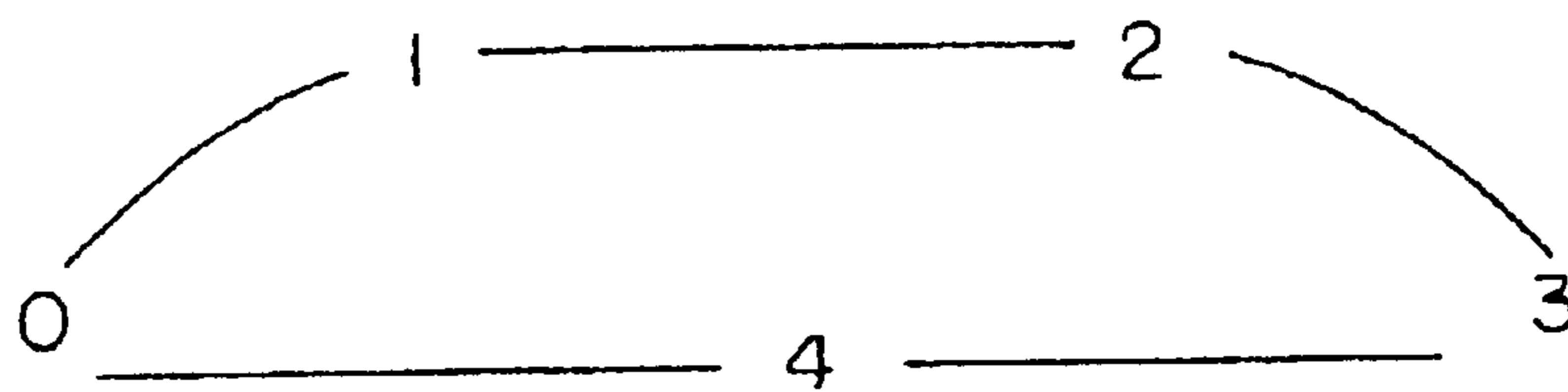

FIG. 5B

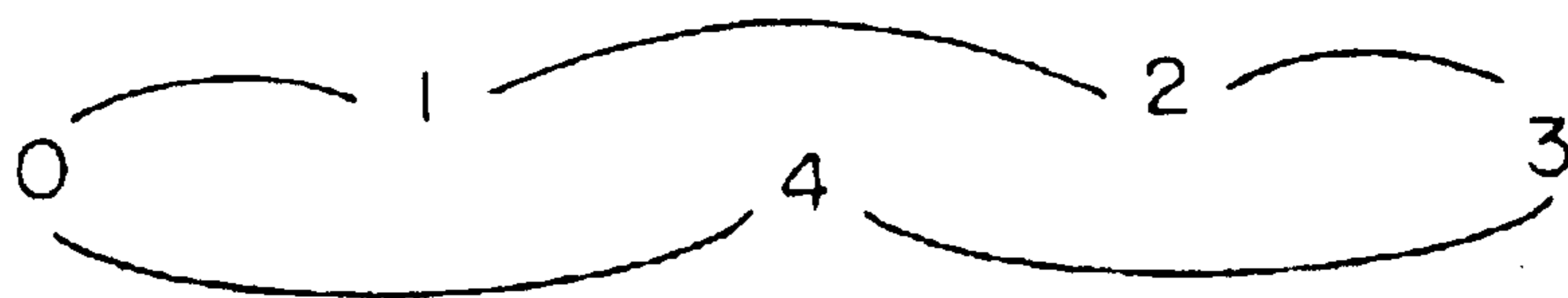

FIG. 5C

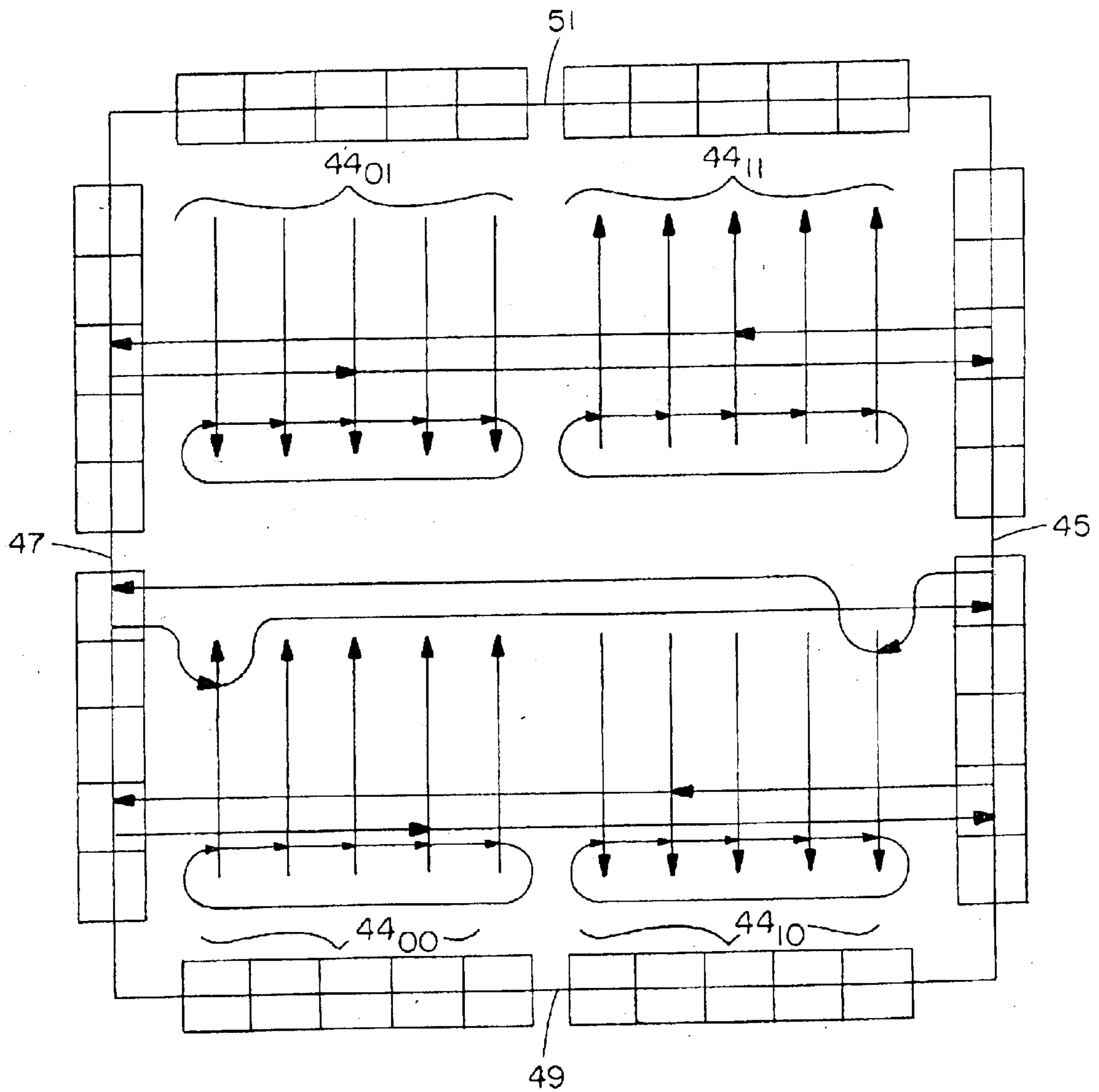

FIG. 6



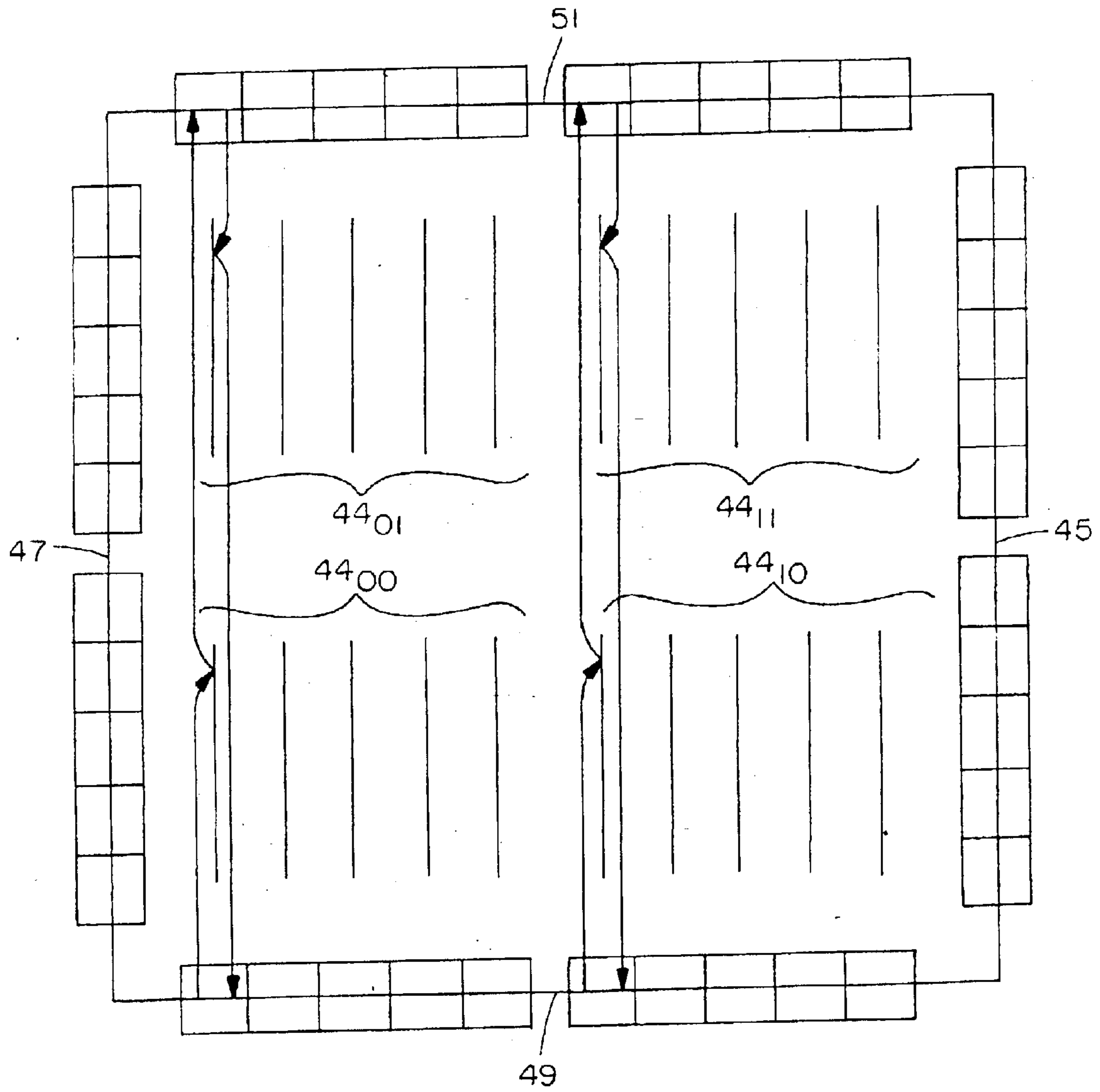

FIG. 7

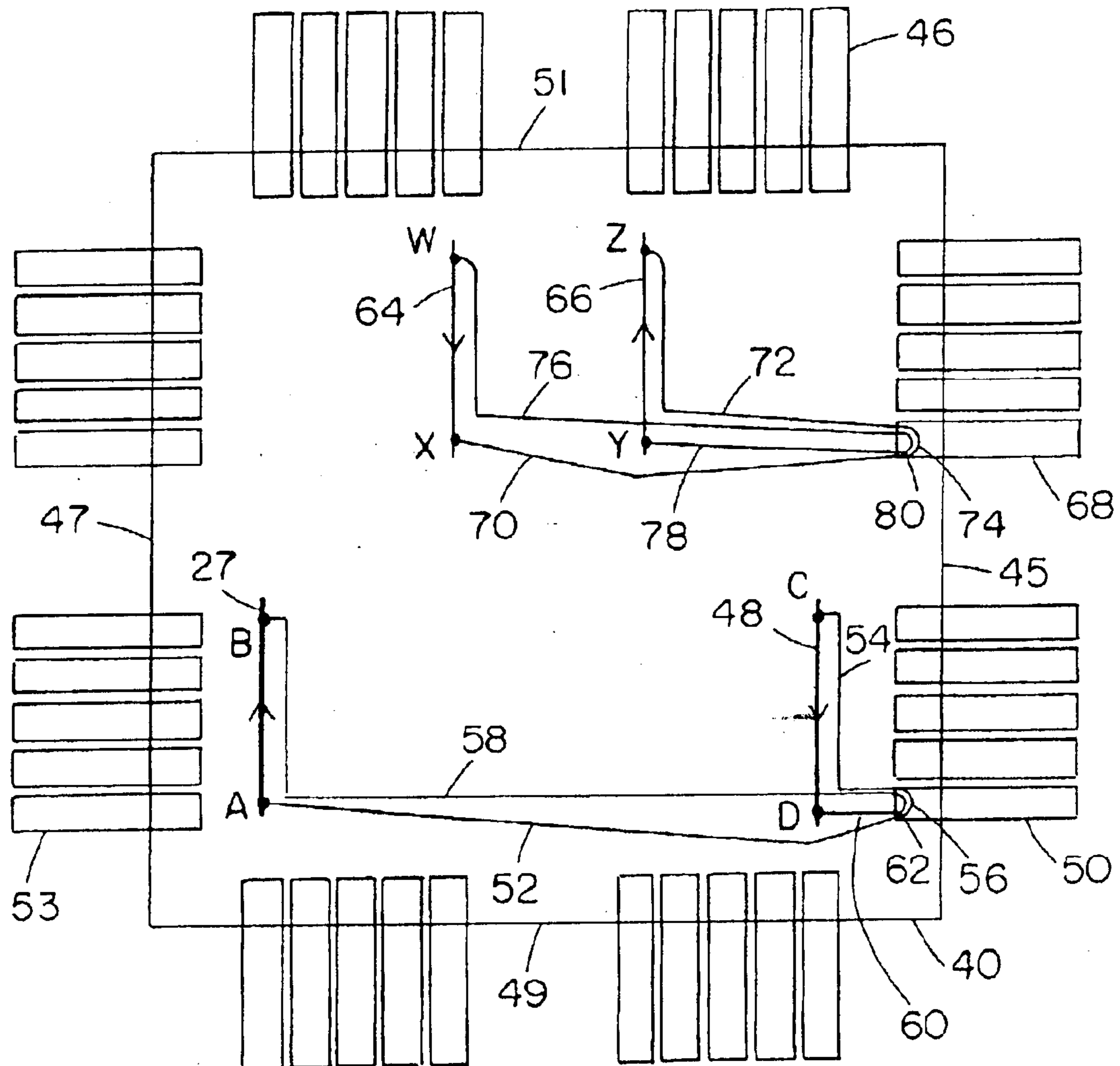

FIG. 8

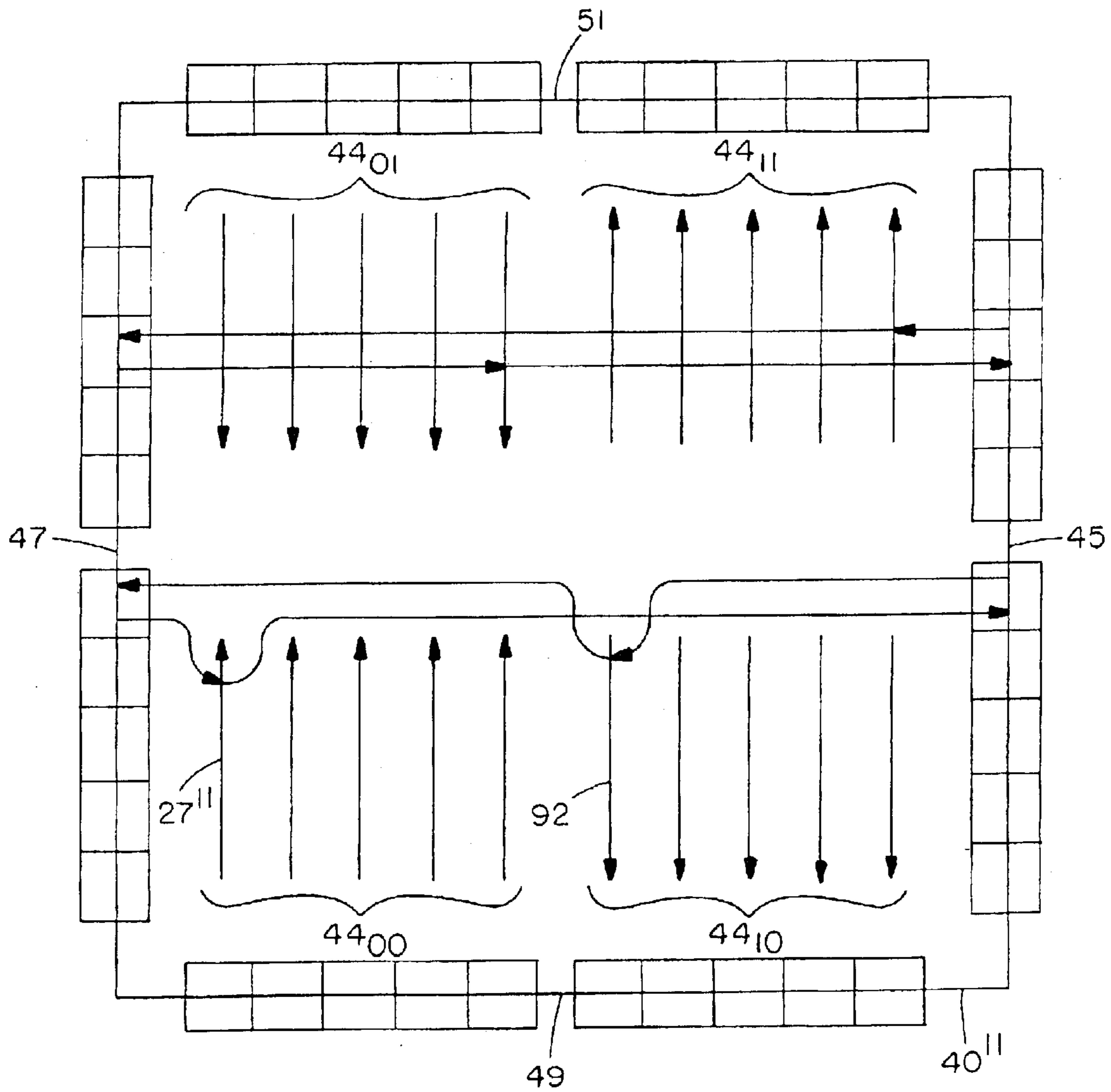

FIG. 9A



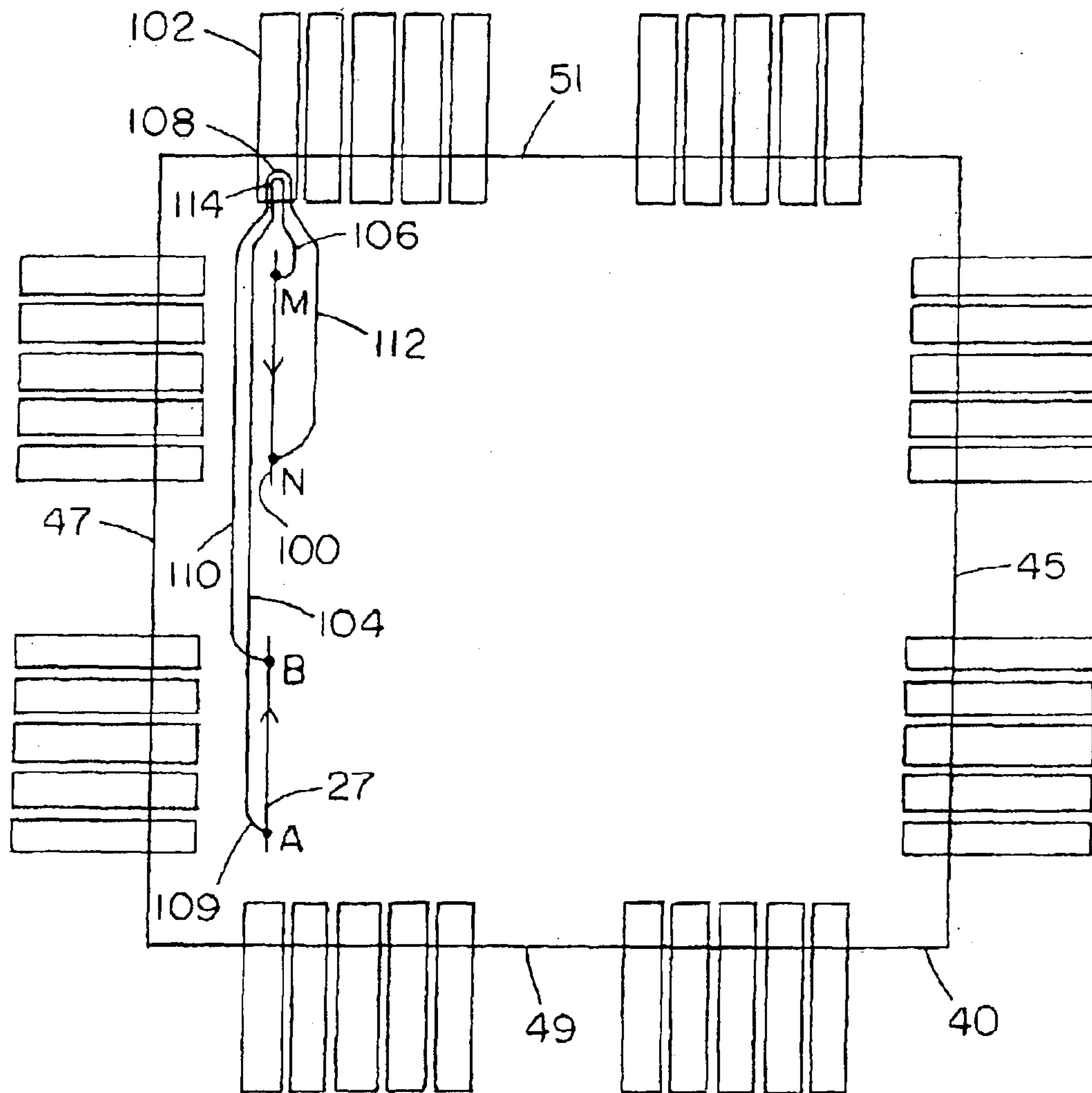

FIG. 10



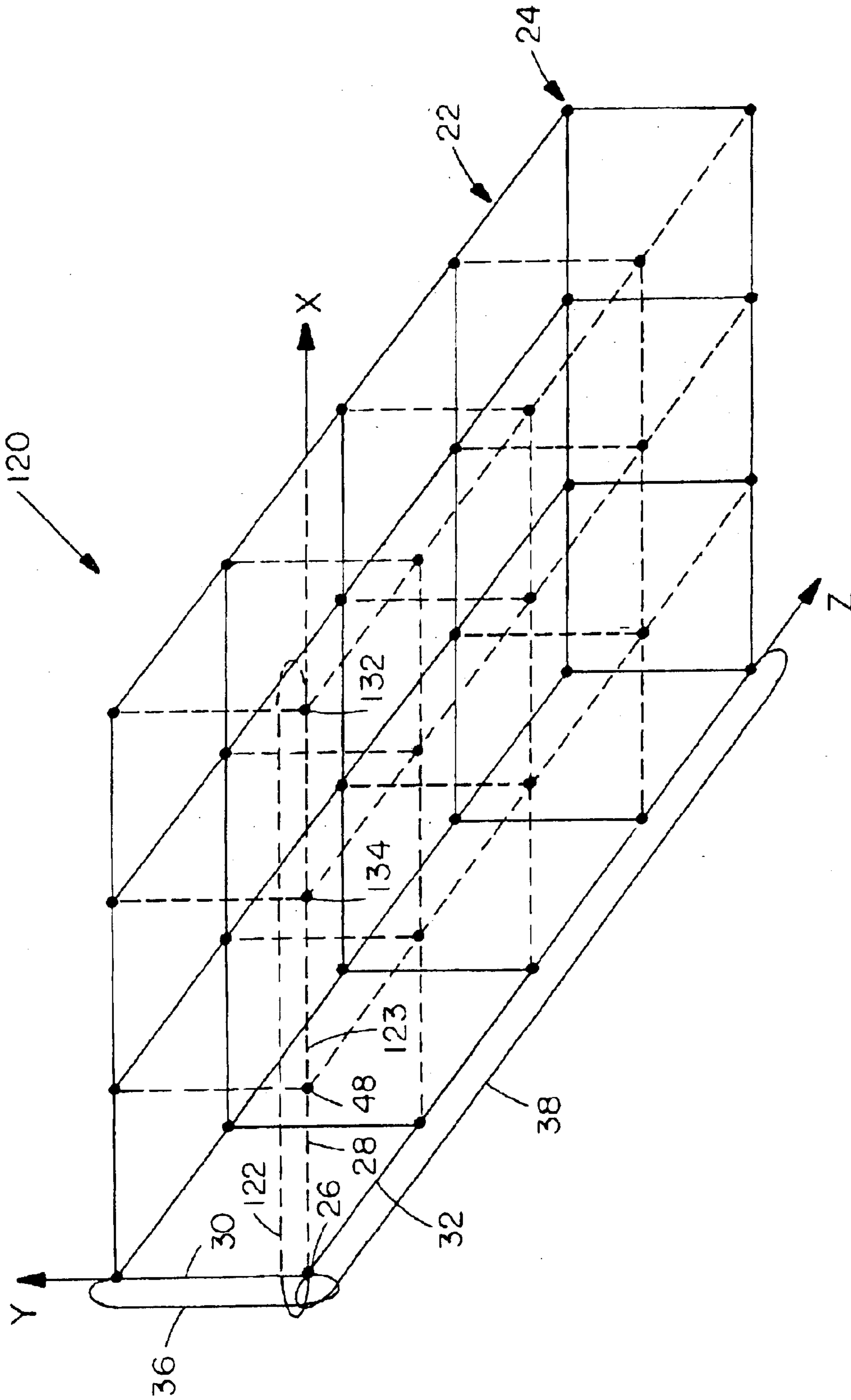

FIG. 11

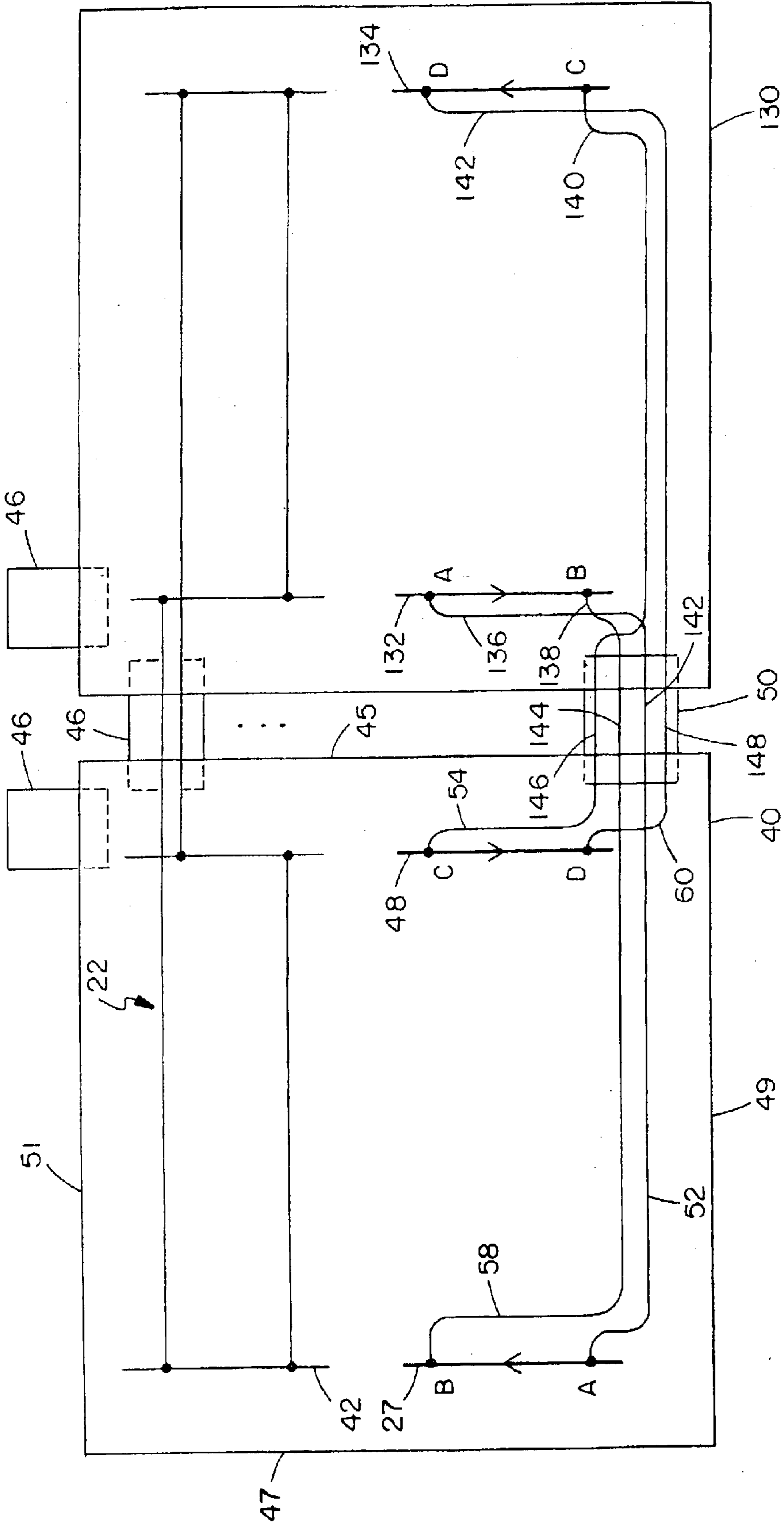

FIG. 12

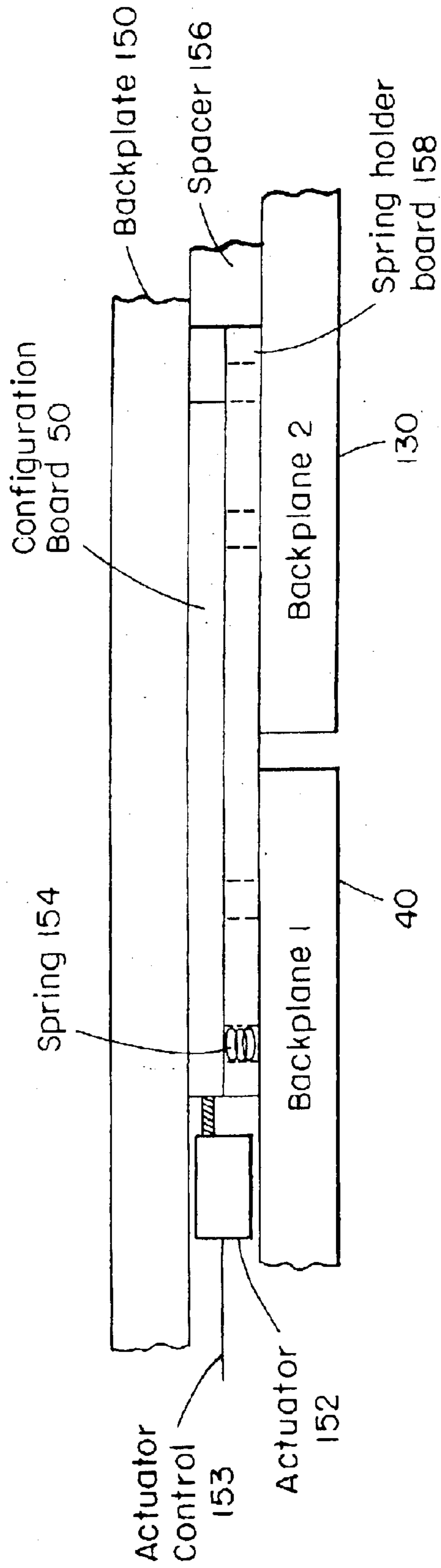

FIG. 13

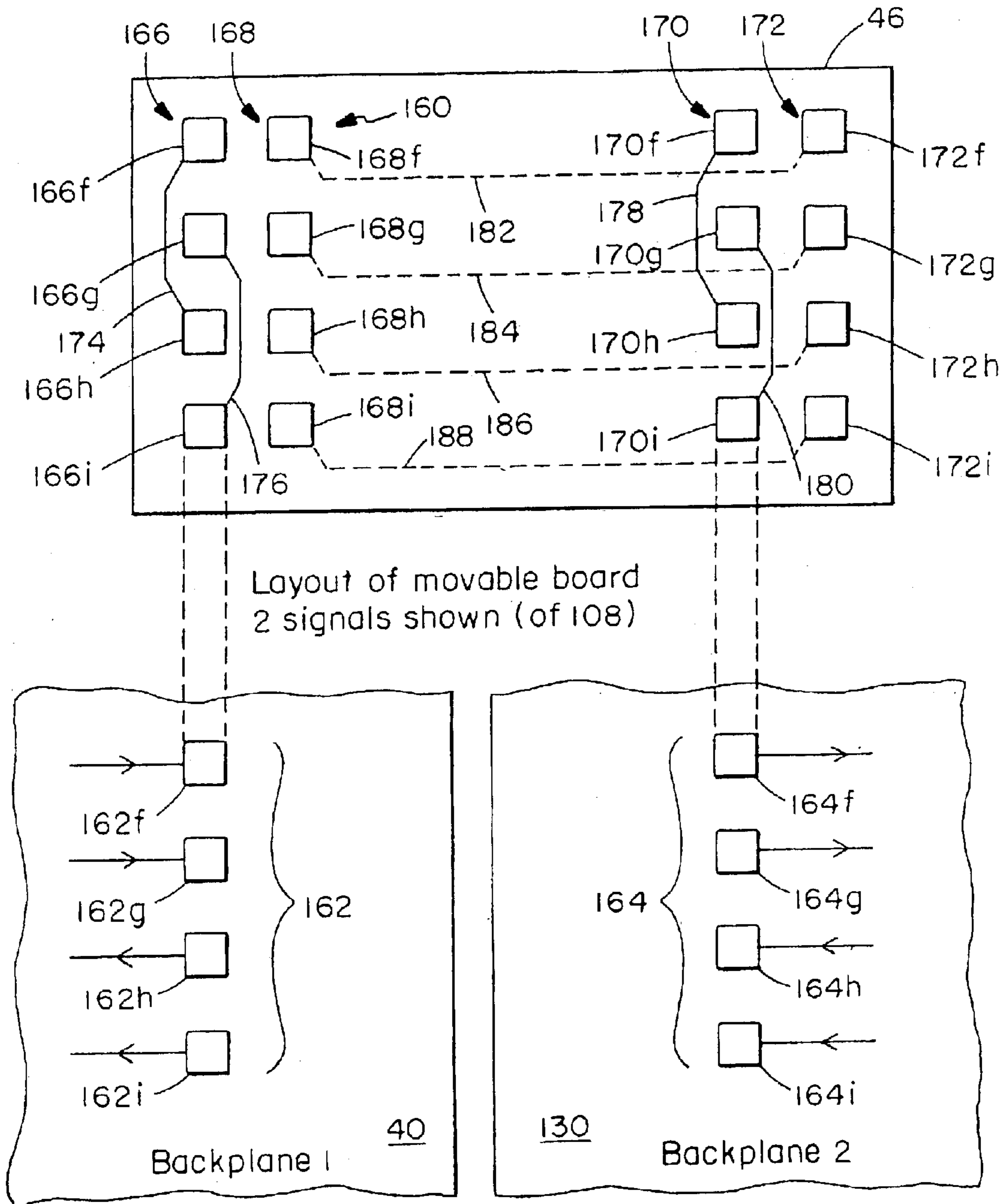

FIG. 14

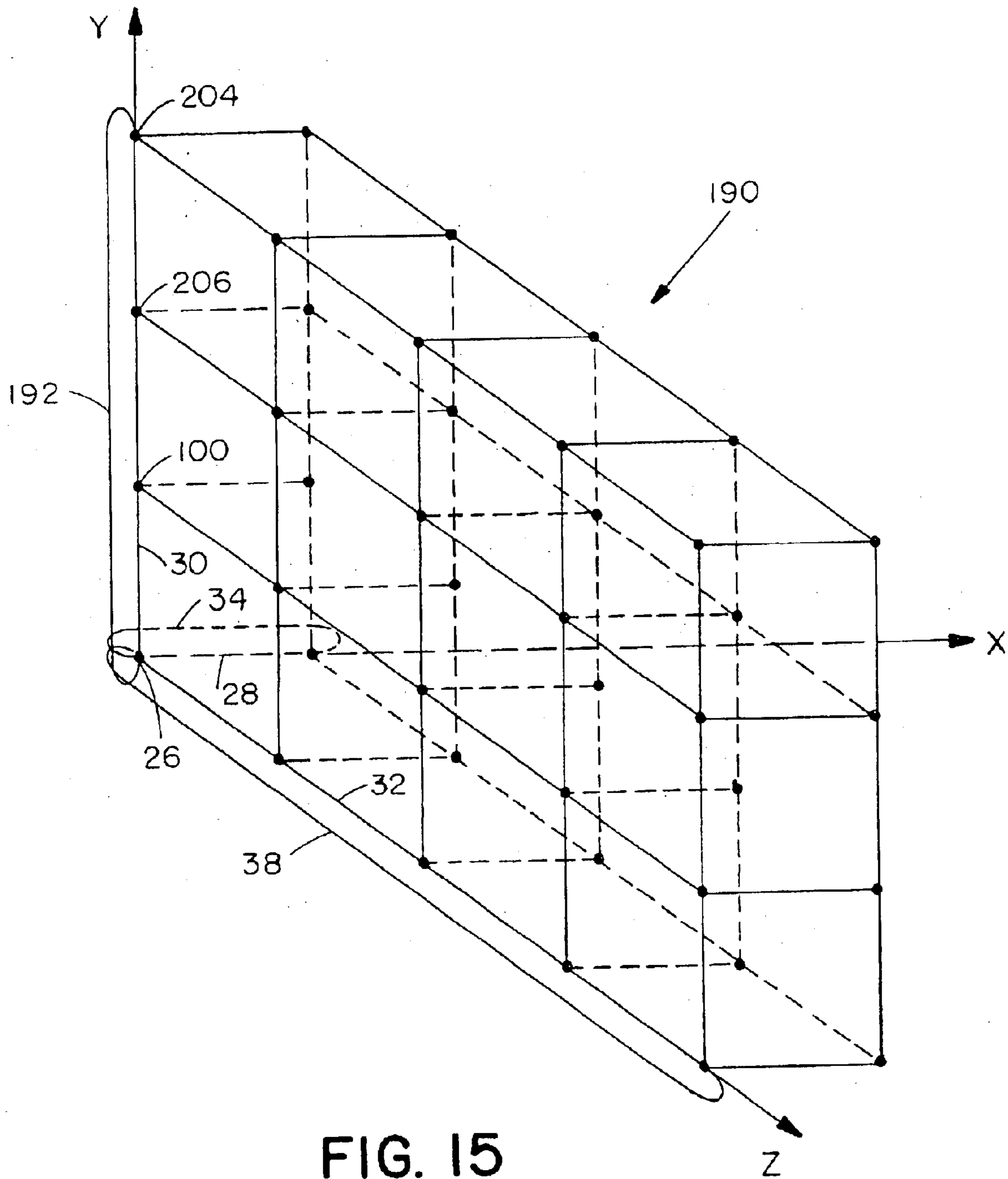

FIG. 15



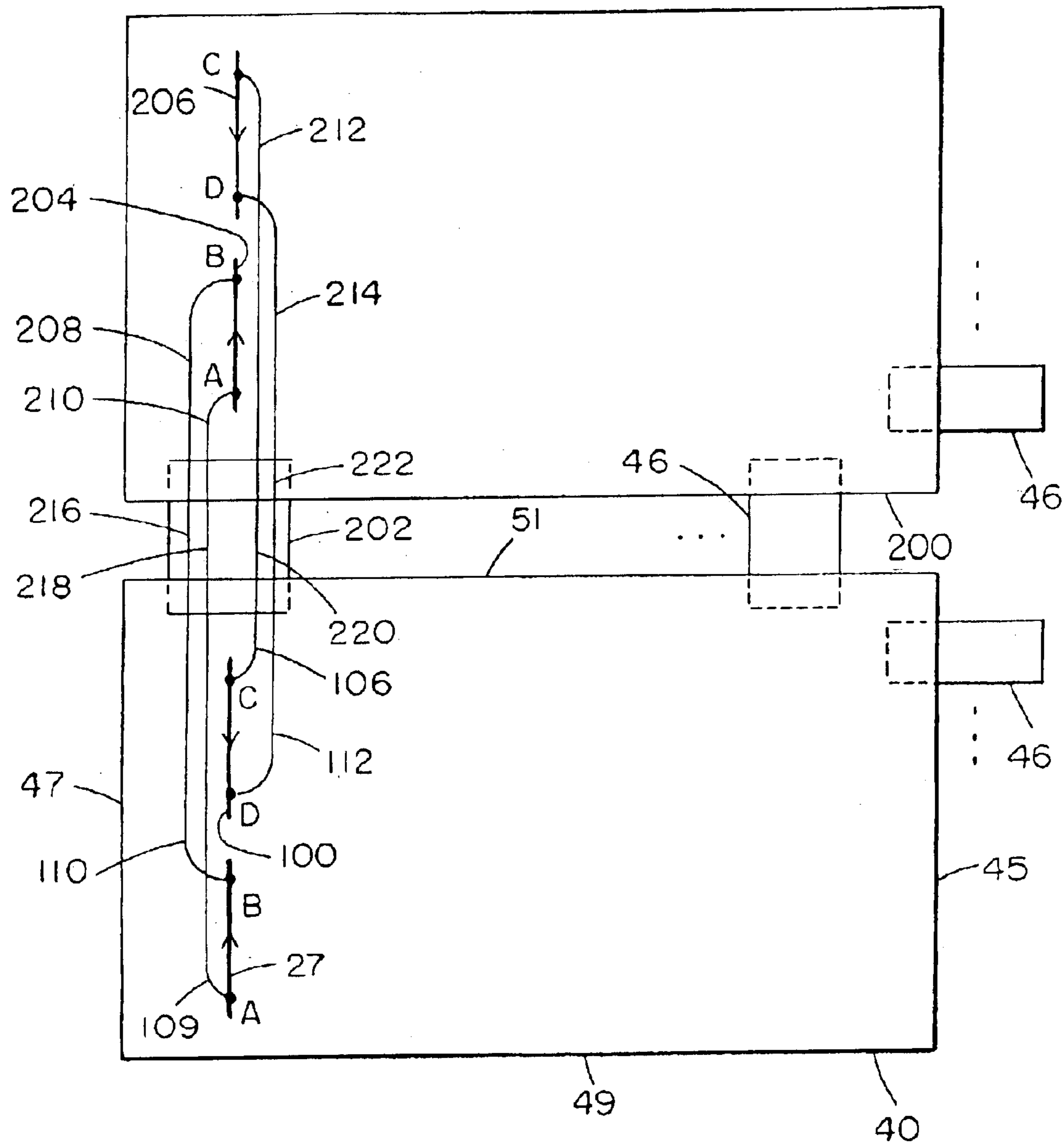

FIG. 16

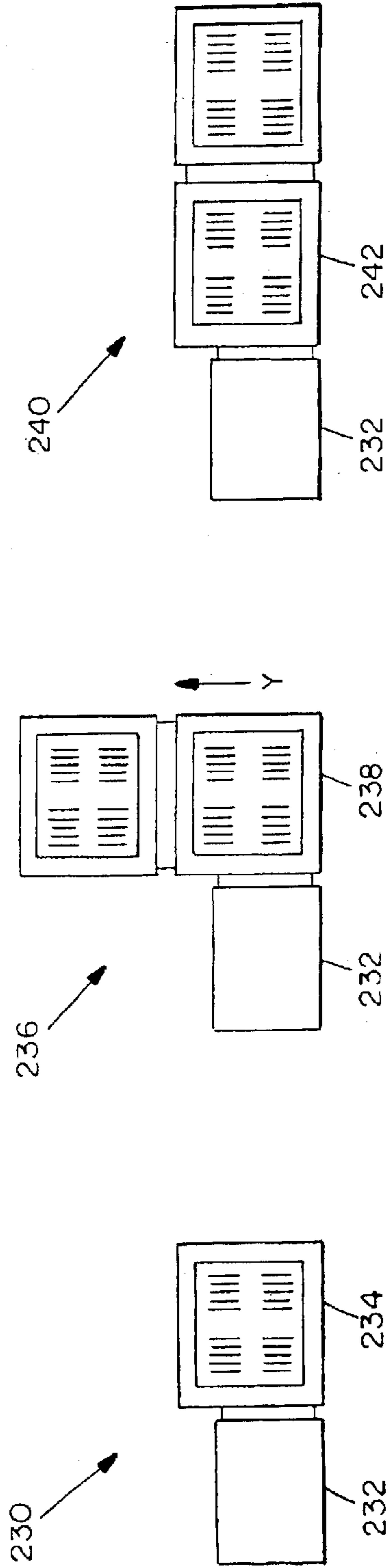

FIG. 17C

FIG. 17B

FIG. 17A

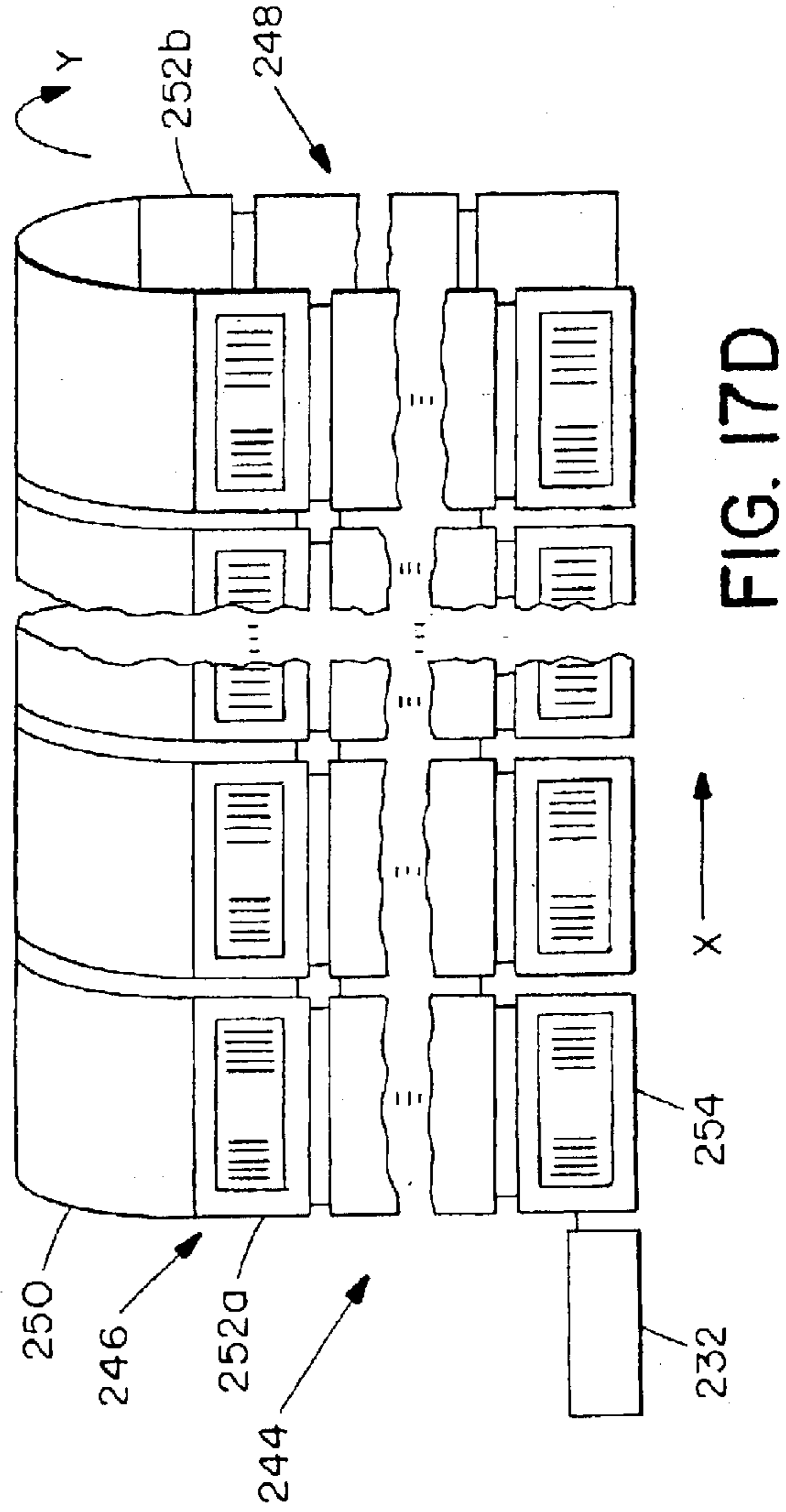

FIG. 17D



## APPARATUS AND METHODS FOR CONNECTING MODULES USING REMOTE SWITCHING

### RELATED APPLICATIONS

This application is a continuation of application Ser. No. 09/765,138, filed Jan. 18, 2001 now U.S. Pat. No. 6,606,656, which is a continuation of application Ser. No. 09/083,722, filed May 22, 1998, now U.S. Pat. No. 6,205,532, which issued on Mar. 20, 2001. The entire teachings of the above applications is incorporated herein by reference.

### BACKGROUND OF THE INVENTION

Computer systems come in a variety of topologies. Systems that include multiple data processing modules (or nodes) often have complex topologies. The interconnection assemblies that connect the modules of such topologies are often complicated, as well. In particular, it is a demanding task for an interconnection assembly to provide several connections (or links) to each module, as required by certain systems having mesh-shaped and torus-shaped configurations.

A typical multi-module computer system has an interconnection assembly that includes a backplane, module connectors and flexible wire cables. The backplane is a rigid circuit board to which the module connectors are mounted. Each module is a circuit board that electrically connects with the backplane when plugged into one of the mounted module connectors. The flexible wire cables connect with the backplane to configure the system into a network topology having a particular size.

The network topology of a typical multi-module computer system is expandable by adding another backplane and reconnecting the flexible wire cables to configure the system into a larger network topology. Generally, the topology of the system is expanded by several modules at a time. For example, one such system having a 4x4x4 torus topology is expanded by adding a 16-module backplane and reconnecting the flexible wire cables to expand the system to a 4x4x5 torus topology. As another example, in a system having 2-D mesh topology, the minimum unit of expansion is a backplane that adds four modules to the system. Some systems permit expansion by hot-plugging, i.e., plugging and unplugging cables to expand the topology of the system while the power remains on.

Examples of some conventional systems that are expandable by several modules at a time are the Paragon made by Intel Corp., of Santa Clara, Calif., and the Cray T3D/T3E made by Cray Research Corp., of Eagan, Minn.

### SUMMARY OF THE INVENTION

Conventional multi-module systems generally do not allow incremental expansion in units of single modules. Rather, such systems typically expand by increasing the topology to the next largest regular network (e.g., adding a 16-module backplane and reconnecting cables to expand a system from a 4x4x4 torus topology to a 4x4x5 torus topology).

In general, the poor extensibility of conventional machines is due to two factors. First, it is often a laborious and error prone process to expand the system at all. Hence, cabled systems are expanded generally by several modules at a time to avoid having to expand the system again in the near future. Second, some conventional machines also employ regular routing algorithms, such as e-cube (or

dimension-order) routing, that only work in a regular (complete) torus or mesh network. Accordingly, such systems could not be expanded incrementally.

The present invention is directed to techniques for incrementally expanding the topology of a multi-module system by connecting modules in a configuration, and changing the configuration remotely. That is, a single module can be added or deleted from the configuration by remotely switching from conducting paths that provide end-around electrical paths (i.e., paths connecting to a single backplane) to conducting paths that provide pass-through electrical paths (i.e., paths extending between two backplanes). Accordingly, the topology of the system can be incrementally changed by a single module by remotely switching conducting paths.

Preferably, the configuration has the capability to take the form of a logical three-dimensional torus. A true torus is at least three modules deep in each dimension, coupled in a loop. When the depth of the configuration drops below three modules in at least one dimension, the configuration is considered a degenerate torus. For simplicity, the term "torus" is used hereinafter to refer to either a true torus (one that is at least three modules deep in each dimension) or a degenerate torus (one that is less than three modules deep in at least one dimension).

A preferred module connection assembly that is suitable for the invention includes two backplanes, a first set of module connectors for electrically connecting modules to one of the backplanes, and a second set of module connectors for electrically connecting modules to the other backplane. The assembly further includes configuration controllers. Each configuration controller selects between end-around electrical paths that electrically connect multiple module connectors of the first set to each other, and pass-through electrical paths that electrically connect module connectors of the first set to module connectors of the second set.

Each configuration controller may operate as a remotely configurable switch that configures a topology formed at least in part by the backplanes and the module connectors. Each configuration controller may include a configuration board that moves between an end-around position connecting nodes on a common backplane and a pass-through position connecting nodes on two backplanes. The configuration controller may further include an actuator that moves the configuration board between the end-around position and the pass-through position. In one embodiment, the actuator is remotely controlled according to an actuator signal.

The assembly may further include a backplate that physically supports the first and second backplanes such that the configuration board is disposed between the backplate and the two backplanes.

Preferably, each configuration board includes end-around pads that electrically connect with the end-around electrical paths, and pass-through pads that electrically connect with the pass-through electrical paths. The backplanes preferably include backplane pads that electrically connect with their respective module connectors. The end-around pads of the configuration board align with the backplane pads of the first backplane when the configuration board is in the end-around position. Similarly, the pass-through pads of the configuration board align with the backplane pads of the first and second backplanes when the configuration board is in the pass-through position.

Each of the end-around and pass-through electrical paths may be cableless paths formed exclusively of rigid metallic material. The paths may be made exclusively of etch, contacts, and springs.



Each backplane provides conducting paths formed preferably of similar rigid metallic material. The conducting paths of the backplanes and the configuration boards combine to form links that connect module connectors of the same backplane when the configuration boards are in their end-around positions, and different links that connect module connectors of different backplanes when the configuration boards are in their pass-through positions. When one configuration board is moved from its end-around position to its pass-through position, at least one module connector is added to the topology. In particular, one end-around link is broken, and two pass-through links to at least one new module connector are formed.

The backplanes connect with modules through the module connectors. Each module can be a fabric routing node such that a network router is formed. Alternatively, each module can be a data processing module such that a multicomputer system is formed.

The backplanes and configuration controllers form a backplane structure that provides links which electrically can connect the plurality of module connectors in a logical torus having multiple dimensions. Each link preferably includes a pair of unidirectional channels. Each channel preferably carries differential signals. The preferred configuration controllers are circuit boards that operate as switches which are remotely controlled to electrically connect the plurality of module connectors in the logical torus. In one embodiment, the logical torus is three dimensional.

The preferred backplane structure electrically connects the module connectors in an interleaved manner. In particular, the module connectors are disposed physically in row segments on the backplane structure. The row segments are disposed physically on the backplane structure in a two dimensional array. The backplane structure electrically connects the row segments in an interleaved manner in each of the two dimensions of the array. The backplane structure may further connect the module connectors in each row segment in an interleaved manner in a third dimension such that the backplane structure electrically connects the module connectors in an interleaved manner in three dimensions.

The module connection assembly provides links that connect the modules of a multi-module system together. An operator can change the topology of the system remotely by switching one or more of the configuration controllers of the system. In particular, the operator can incrementally expand the system by remotely switching just one of the configuration controllers.

The module connection assembly alleviates the need for using wire cables. Accordingly, the operator does not need to search for the correct cables in a maze of cables, plug and unplug cables, and work with cables in tight places. Additionally, the present invention allows for higher connection density, i.e., connections per inch or board perimeter than that of a typical conventional cabled system.

Furthermore, the module connection assembly is remotely switchable so that the operator is not hindered by space limitations. Accordingly, the topology can be reconfigured without needing to gain access to the back of the system. Also, with remote actuation, it is easy to make sure that the correct paths are being modified when changing the topology of the system. That is, the remote activation reduces the likelihood of connection errors (e.g., plugging a cable into an incorrect location, or incorrectly plugging a cable into a correct location). Additionally, the cost per signal is substantially lower than with a cable. Furthermore, signal integrity is preserved, i.e., the signal remains in a good

100-ohm differential transmission line environment through the connector. In contrast, a cable, and its two connectors, usually involve a significantly greater impedance discontinuity.

#### BRIEF DESCRIPTION OF THE DRAWINGS

The foregoing and other objects, features and advantages of the invention will be apparent from the following more particular description of preferred embodiments of the invention, as illustrated in the accompanying drawings in which like reference characters refer to the same parts throughout the different views. The drawings are not necessarily to scale, emphasis instead being placed upon illustrating the principles of the invention.

FIG. 1 is a logical view of modules linked together in a 2x2x5 torus arrangement according to the invention.

FIG. 2 is a view of a backplane with module connectors, and configuration boards.

FIG. 3 is a view of the backplane of FIG. 2 with links in the Z-direction.

FIG. 4 is a view of the backplane of FIG. 2 with interleaved links in the Z-direction.

FIGS. 5A–C are views of physical positions for module connectors of row segments of the backplane of FIG. 2.

FIG. 6 is a view of the backplane of FIG. 2 with links in the X and Z directions.

FIG. 7 is a view of the backplane of FIG. 2 with links in the Y-direction.

FIG. 8 is a view of the backplane of FIG. 2 showing particular etches connecting module connectors in the X-direction.

FIG. 9A is a view of the backplane of FIG. 2 with alternative links in the X-direction.

FIG. 9B is a view of the backplane of FIG. 9A showing particular etches connecting module connectors in the X-direction.

FIG. 10 is a view of the backplane of FIG. 2 showing particular etches connecting module connectors in the Y-direction.

FIG. 11 is a logical view of modules linked together to form a 4x2x5 torus arrangement according to the invention.

FIG. 12 is a view of two backplanes linked in the X-direction by a configuration board.

FIG. 13 shows a side view of the two backplanes and the configuration board of FIG. 12.

FIG. 14 shows pad layouts for the two backplanes and the configuration board of FIG. 12.

FIG. 15 is a logical view of modules linked together to form a 2x4x5 torus arrangement according to the invention.

FIG. 16 is a view of two backplanes linked in the Y-direction by a configuration board.

FIGS. 17A–D are system views of module connection assemblies including various assembly configurations according to the invention.

#### DETAILED DESCRIPTION OF THE INVENTION

A description of preferred embodiments of the invention follows.

The present invention connects together modules of a multi-module data processing system such as an internet router formed by a network of fabric routers, or a multi-computer system. Internet switch routers formed by net-



works of fabric routers are described in application Ser. No. 08/918,556, filed Aug. 22, 1997, the entire teachings of which are incorporated herein by reference. Multicomputer networks are described in detail in Dally, W. J., "Network and Processor Architectures for Message-Driven Computing," *VLSI and PARALLEL COMPUTATION*, Edited by Suaya and Birtwistle, Morgan Kaufmann Publishers, Inc., 1990, pp. 140-218, the entire teachings of which are incorporated herein by reference.

A logical view of a multi-module data processing system **20** (e.g., an internet router or a multicomputer system) is shown in FIG. 1. The system **20** includes links **22** and modules **24**. The links **22** connect the modules **24** in a three-dimensional torus arrangement. In particular, the multi-module system **20** is a  $2 \times 2 \times 5$  arrangement. That is, the system **20** is two modules wide in the X-direction, two modules high in the Y-direction, and five modules long in the Z-direction.

Each module **24** of the system **20** has six links which extend in six logical directions to other modules. For example, the module **26** located at the origin (the intersection of the X, Y and Z axes) has a link **28** that extends in the positive X-direction, a link **30** that extends in the positive Y-direction, a link **32** that extends in the positive Z-direction, a link **34** that extends in the negative X-direction, a link **36** that extends in the negative Y-direction, and a link **38** that extends in the negative Z-direction.

The links **34**, **36** and **38** are end-around connection links that link chains of modules **24** in a loop configuration. That is, the link **34** links two modules extending in the X-direction in a loop, the link **36** links two modules extending in the Y-direction in a loop, and the link **38** links five modules extending in the Z-direction in a loop. Without such torus-connection links, the system **20** would have a mesh configuration rather than a torus configuration. Though described as special torus connection links and seen as such in the FIG. 1 illustration, through the use of interleaving described in detail below, such links become indistinguishable from other links. The arrangement is more particularly a degenerate torus arrangement since the arrangement is less than three modules deep in the X and Y directions.

Each of the other modules **24** has six links which extend to other modules, although for simplicity not all of the links **22** are shown in FIG. 1. Nevertheless, it should be understood that the  $2 \times 2 \times 5$  system **20** includes 20 links in the X-direction, i.e., 10 standard links (10 shown) and 10 torus-connection links (only one shown). Similarly, the system **20** includes 20 links in the Y-direction, i.e., 10 standard links (10 shown) and 10 torus-connection links (only one shown). Furthermore, the system **20** includes 20 links in the Z-direction, 16 standard links (16 shown) and 4 torus-connection links (only one shown).

The system may be expanded to any size (e.g., to contain any number of modules), and may be expanded in any dimension. The preferred system supports a basic  $2 \times 2 \times 5$  toroid on a single motherboard (or backplane), and can be populated in the X, Y or Z directions on a module by module basis until the single motherboard is fully populated. Then, the system may be expanded incrementally into adjacent motherboards, each supporting up to a  $2 \times 2 \times 5$  array. Alternatively, adjacent motherboards can be populated with one or more modules before the first motherboard is fully populated.

Although the links are shown as single wires, each link includes two unidirectional channels. Each unidirectional

channel carries differential signals. Preferably, each link uses 112 conductors, 56 conductors for each channel. The 56 conductors carry 28 differential signals including a clock signal, a synchronization signal, a select signal, a credit signal, and 24 data bit signals. The credit signal for a given channel travels in a direction opposite to the direction of the other 27 signals.

A module connection assembly that is suitable for the multi-module system **20** of FIG. 1 is shown in FIG. 2. The assembly includes a backplane **40**, module connectors **42**, and configuration boards **46**. Each module connector **42** electrically connects a module **24** (e.g., a fabric router of an internet switch router, or a processor of a multicomputer system) with the backplane **40**. For example, the module connector **27** electrically connects the module **26** (see FIG. 1) with the backplane **40**. The backplane **40** has four edges **45**, **47**, **49** and **51**. Ten configuration boards **46** are positioned along each edge to allow for end-around connection of torus connection links as illustrated in FIG. 1 or standard links with X and Y dimensions to adjacent motherboards as will be described below. The backplane **40** and the configuration boards **46** provide conductors that form the links **22** which connect the module connectors **42** in the torus arrangement illustrated in FIG. 1. Preferably, the backplane **40** includes 22 layers of conductors including 9 pairs of signal layers, two signal return layers, and two ground layers. Each pair of signal layers carries differential signals with one signal conductor on each layer of the pair.

The module connectors **42** are arranged in row segments **44**. In particular, the module connectors **42** are grouped into four row segments **44<sub>00</sub>**, **44<sub>10</sub>**, **44<sub>01</sub>** and **44<sub>11</sub>**, that correspond to the four XY quadrants **00**, **10**, **01** and **11**, of the backplane **40**. In particular, segment **44<sub>00</sub>** of module connectors **42** electrically connects modules to the backplane **40** to form the row of modules **24** along the Z-axis, as shown in FIG. 1. Segment **44<sub>10</sub>** forms the row that is parallel to the Z-axis, displaced in the positive X-direction. Segment **44<sub>01</sub>** forms the row that is parallel to the Z-axis, displaced in the positive Y-direction. Segment **44<sub>11</sub>** forms the row that is parallel to the Z-axis, displaced in the positive X and Y directions.

The modules **24** that electrically connect with the backplane **40** are circuit boards having electrical contacts (e.g. pins or sockets) along an edge. The module connectors **42** have matching contacts that individually connect with the contacts of the circuit boards. In particular, both the modules **24** and the module connectors **42** have a series of contacts arranged from a least significant bit (LSB) to most a significant bit (MSB). As shown in FIG. 2, the module connectors **42** are oriented such that each connector **42** of row segment **44<sub>00</sub>** has its LSB near the periphery of the backplane **40**, and its MSB near the interior of the backplane **40**. Similarly, each module connector **42** of the row segment **44<sub>01</sub>** has its LSB near the periphery of the backplane **40**, and its MSB near the interior of the backplane **40**. In contrast, each module connector **42** of row segments **44<sub>10</sub>** and **44<sub>11</sub>** has its MSB near the periphery of the backplane **40**, and its LSB near the interior of the backplane **40**.

The module connectors **42** preferably are connected by links **22** in the Z-direction in the manner logically shown in FIG. 3. As shown, the module connectors **42** of each segment are connected in a loop. Accordingly, each module connector **42** has two links **22** leading to other module connectors **42** in the Z-direction. For example, the module connector **27** has two links **32** and **38** (also see FIG. 1) that lead to other module connectors in segment **44<sub>00</sub>**.

In FIG. 3 it can be seen that within each segment there are four links **31** to adjacent modules, and a final end-around



connection 33 which is at least four times as long. To minimize the critical longest connection, the module connectors 42 can be connected by links in the Z-direction in an interleaved manner as logically shown in FIG. 4. Here, the module connectors 42 of each segment of a backplane 40' are still connected in a loop, but each module connector 42 in a segment is connected through a link to another connector 42 of that segment that is at most two module connector positions away. For example, the module connector 27' is connected through the link 32' to a module connector that is one module position away, and through the link 38' to another module connector that is two positions away. This interleaving arrangement minimizes the longest link to at most two module connector positions in length. In contrast, the longest link in the non-interleaved arrangement of FIG. 3 is four module connector positions in length. Since signal propagation time is reduced by decreasing link length, the interleaving arrangement of FIG. 4 minimizes the longest link to two positions in length, and provides reduced signal propagation time over the non-interleaving arrangement of FIG. 3.

A method for interleaving the row segments 44 shown in FIG. 3 is illustrated in FIGS. 5A-5C. FIG. 5A shows the connection order and physical positioning for the module connectors 24 of one of the row segments 44 in FIG. 3. In FIG. 5B, the connection order for the module connectors 24 is preserved, but the positioning of the module connectors 24 is rearranged. In FIG. 5C, the connection order for the module connectors 24 is still preserved, but the positioning of the module connectors 24 is arranged again as a row segment but with the longest connection being at most two module connector positions away. The module connector positions for each row segment 44 are shown in FIG. 4.

The module connectors 42 are connected to configuration boards at the edge of the backplane in the X and Y directions as illustrated in FIGS. 6 and 7. As shown in FIG. 6, the modules in each of the four segments 44 are connected in different directions. Segments 44<sub>00</sub> and 44<sub>01</sub> have the +X channels connected to the right edge 45 and their -X channels connected to the left edge 47. Segments 44<sub>10</sub> and 44<sub>11</sub> are connected in the opposite X direction with their +X channels connected to the left edge 47 and their -X channels connected to the right edge 45. Similarly, as shown in FIG. 7, segments 44<sub>00</sub> and 44<sub>10</sub> are connected in one direction in the Y dimension, with their +Y channels connected to the top edge 51 and their -Y channels connected to the bottom edge 49. Segments 44<sub>01</sub> and 44<sub>11</sub> are connected in the opposite Y direction. As will be shown below, this wiring of the backplane facilitates interleaving of backplanes when forming loops in the X and Y directions in large machines since each backplane contributes modules to both the forward and reverse part of the loops in each dimension.

To allow for expansion, the backplane 40 and configuration boards 46 provide the links 22 between the module connectors 42 (see FIG. 2). In particular, each of the 20 X-direction links of the system 20 passes through a corresponding configuration board 46 positioned along the edge 45, or the edge 47 which is opposite the edge 45. Similarly, each of the 20 Y-direction links passes through a corresponding configuration board 46 positioned along the edge 49 or the edge 51 which is opposite the edge 49.

More particularly, each link 22 is formed by multiple conducting paths (e.g., 112 conductors) between the module connectors 42, each conducting path carrying a bit of information (an electrical signal) from one module connector to another. The conducting paths for each link 22 in the X-direction are formed by conductors in the backplane 40

and in one of the configuration boards 46 positioned along the edge 45 or the edge 47. For example, as shown in FIG. 8, the conducting paths that form the link 34 (see FIG. 1) extend from the module connector 27 to the module connector 48, through a configuration board 50 along the edge 45. As shown, a first conducting path connects a bit A of the module connector 27 and a bit C of the module connector 48. This path includes conductors 52 and 54 of the backplane 40, and a conductor 56 of the configuration board 50. Similarly, a second conducting path connects a bit B of the module connector 27 and a bit D of the module connector 48. This second path includes conductors 58 and 60 of the backplane 40, and a conductor 62 of the configuration board 50. It should be understood that not all of the conducting paths for each link are shown in FIG. 8 for simplicity, and that each link includes several conducting paths (e.g., 112 conducting paths).

Module connectors in segment 44<sub>00</sub> and 44<sub>10</sub> are oriented with their LSBs in opposite directions to bound the total wire length of channels in the X direction. With this arrangement, the maximum length of an X channel is the width of the backplane plus the height of one module irrespective of the position of the configuration board that is used to complete the connection. This length is required by both the LSB and MSB of a channel. The intermediate bits may have shorter lengths depending on the position of the configuration board. If the module connectors were arranged in the same direction in these adjacent segments a channel wire could be as long as the width of the backplane plus twice the height of the module connector if the configuration board is at one end of the module connector.

Other configuration boards 46 provide other X-direction links 22. There is one configuration board along the right edge 45 of the backplane and one board along the left edge 47 of the backplane for each pair of module connectors in the backplane. Each configuration board is associated with one connector in segments 44<sub>00</sub> or 44<sub>01</sub> and one connector in segments 44<sub>10</sub> or 44<sub>11</sub>. Each configuration board connects module connectors that differ only in their X coordinate. They share the same Y and Z coordinates. For example, as further shown in FIG. 8, conducting paths form a link that extends from a module connector 64 to the module connector 66, through a configuration board 68 along the edge 45. In particular, a first conducting path connects a bit W of the module connector 64 and a bit Y of the module connector 66. This path includes conductors 76 and 78 of the backplane 40, and a conductor 80 of the configuration board 68. Similarly, a second conducting path connects a bit X of the module connector 64 and a bit Z of the module connector 66. This second path includes conductors 70 and 72 of the backplane 40, and a conductor 74 of the configuration board 68.

It should be understood that bits A, C, W and Y correspond to LSBs of their respective module connectors 42, as shown in FIG. 2. Similarly, bits B, D, X and Z correspond to MSBs of their respective module connectors 42.

The configuration boards along the edge 47 form similar X-direction links between the module connectors 42. For example, configuration board 53 provides link 28 that further connects the module connectors 27 and 48. Accordingly, each of the 20 X-direction links 22 is formed by the conductors of the backplane 40 and the conductors of one of the 20 configuration boards 46 positioned along the edges 45 and 47.

As shown in FIGS. 6 and 8, the outermost module connectors 42 (the module connectors closest to the edges



45 and 47) are linked together. Similarly, the next outermost module connectors 42 are linked together, and so on. This layout is preferable to a layout linking the leftmost module connectors together (e.g., linking the module connectors of segments 44<sub>00</sub> and 44<sub>10</sub> that are closest to the edge 47), the next leftmost module connectors together, and so on, as will now be discussed.

To illustrate the length of the chosen layout of modules in FIGS. 6 and 8 consider an alternative conducting path arrangement which might have been chosen for the backplane 40. Recall that the conducting paths of FIG. 8 correspond to the X-direction links 22 shown logically in FIG. 6. If the X-direction links 22 are arranged differently, the conducting paths arrangements will differ as well. For example, an alternative X-direction link arrangement shown in FIG. 9A would be logically suitable for the backplane 40. FIG. 9B shows conducting path arrangements for the FIG. 9A X-direction link arrangement. A conducting path between module connectors 27" and 92 includes conductors 94 and 96 of the backplane 40, and a conductor 98 of the configuration board 50. Similarly, a conducting path between module connectors 82 and 84 includes conductors 86 and 88 of the backplane 40, and a conductor 90 of the configuration board 68.

However, from a comparison of the lengths of the conducting paths of FIGS. 8 and 9B, it should be understood the conducting paths in FIG. 8 provide better minimization of the longest conducting path. In particular, for FIG. 8, the conducting paths between the outer module connectors 27 and 48 include a long conductor (e.g., 52 or 58) and a short conductor (e.g., 54 or 62). At the other extreme, the conducting paths between the inner module connectors 64 and 66 include two intermediate length conductors (e.g., 70,72 or 76,78). The FIG. 8 conducting paths formed by long and short conductors approximately equal the FIG. 8 conducting paths formed by two intermediate length conductors. In contrast to the FIG. 8 conducting paths, in FIG. 9B, all links include an intermediate length conductor along with a conductor ranging from short to long, resulting in a range of overall lengths and a critical maximum length which is longer than in FIG. 8. For example, the conducting path that connects module connectors 27" and 92 includes a long conductor 94 and an intermediate conductor 96. This conducting path is substantially longer than those formed by an long and short conductor, or two intermediate conductors, as shown in FIG. 8. Accordingly, the FIG. 8 conducting path arrangement and the FIG. 6 link arrangement provides better minimization of the longest conducting paths than those of FIGS. 9B and 9A.

Each Y-direction link 22 is also formed by multiple conducting paths provided by the backplane 40 and one of the configuration boards 46 positioned along the edges 49 and 51. For example, as shown in FIG. 10, the conducting paths that form the link 30 (see FIG. 1) extend from the module connector 27 to the module connector 100, through a configuration board 102 positioned along the edge 51. In particular, a first conducting path connects the bit A of the module connector 27 and a bit M of the module connector 100. This path includes conductors 109 and 106 of the backplane 40, and a conductor 114 of the configuration board 102. Similarly, a second conducting path connects the bit B of the module connector 27 and a bit N of the module connector 100. This second path includes conductors 110 and 112 of the backplane 40, and a conductor 108 of the configuration board 102. Note that since the order of least significant bit to most significant bit is reversed between the lower and upper quadrants, the conductor lengths range

from long-plus-short to intermediate-plus-intermediate lengths, thus maintaining approximately equal combined lengths in the Y direction as well.

Other configuration boards 46 positioned along the edges 49 and 51 provide the other Y-direction links 22 of the system 20. That is, each of the 20 Y-direction links 22 is formed by the conductors of the backplane 40 and the conductors of one of the 20 configuration boards 46 positioned along the edge 49 or the edge 51.

By providing individual configuration boards along each edge, the system 20 is incrementally expandable. That is, the topology of the system has the capability of expanding in a scalable manner, one module (or module connector) at a time. To this end, each configuration board 46 acts as a remotely configurable switch, or a configuration controller, that selectively provides end-around electrical paths and pass-through electrical paths. The configuration board conductors described thus far (e.g., the configuration board conductors 56 and 62 in FIG. 8) provide end-around electrical paths. Each configuration board 46 further includes conductors that provide pass-through electrical paths, as will now be described in connection with FIGS. 11-16.

The system 20 is adaptable so that additional backplanes can be added to the system. When another backplane is added, and when each of the configuration boards along an edge of the backplane 40 provides pass-through electrical paths rather than end-around electrical paths, the size of the system 20 doubles forming a larger system 120. That is, the number of modules (or module connectors) in the system 120 is twice that of the system 20. A logical view of such a multi-module data processing system 120 is shown in FIG. 11. The system 120 includes links 22 and modules 24 that form a three-dimensional torus arrangement. In particular, the multi-module system is a 4x2x5 arrangement. That is, the system 120 is four modules wide in the X-direction, two modules high in the Y-direction, and five modules long in the Z-direction.

As in the system 20, each module 24 of the system 120 has six links which extend in six logical directions to other modules. For example, the module 26 located at the origin (the intersection of the X, Y and Z axes) has a link 28 that extends in the positive X-direction, a link 30 that extends in the positive Y-direction, a link 32 that extends in the positive Z-direction, a torus-connection link 122 that extends in the negative X-direction, a torus-connection link 36 that extends in the negative Y-direction, and a torus-connection link 38 that extends in the negative Z-direction. Similarly, the other modules have six links which extend to other modules, although for simplicity not all of the links are shown in FIG. 11.

By comparing FIG. 11 to FIG. 1, it can be seen that the expanded array 120 of FIG. 11 is formed by breaking end-around links in the X-direction (e.g., link 34 in FIG. 1) and by replacing each broken link with a pair of pass-through links (e.g., a standard link 123 and a torus connection link 122).

The movement of configuration boards from the end-around position to the pass-through position is performed one configuration board at a time to facilitate incremental expansion of the system. Switching a single configuration board extends one of the "loops" in the X direction from 2-nodes to 4-nodes while leaving all other X-loops at 2-nodes. For example, switching configuration board 50 in FIG. 12 connects modules connectors 27, 48, 134, 132 in a loop while leaving the rest of the network in the 2x2x5 configuration shown in FIG. 1. By switching one configu-



ration board at a time, the system can be expanded in increments of two modules as compared to prior art systems that required maintaining a regular topology and expanding in increments of one or more whole backplanes.

Addition of a single module can be achieved by switching a single configuration card and then inserting the new module and a dummy module into the two connectors added to an X-loop by this action. The dummy module acts as a repeater to complete the connection around the cycle in the X-direction and can be replaced by a real module when the system is next expanded.

A module connection assembly that is suitable for the multi-module system **120** of FIG. **11** is shown in FIG. **12**. The assembly includes a first backplane **40**, a second backplane **130**, module connectors **42**, and configuration boards **46**. Backplane **130** is identical to backplane **40** except that each of its module connectors are oriented in the opposite direction from backplane **40**. Backplane **130** is realized using the same circuit board type as backplane **40** rotated 180 degrees to give this reversal of module connector orientations. This reversal of connector orientation of alternating backplanes keeps the maximum wire length for a channel less than the width of the backplane plus the height of a module irrespective of which configuration card the channel passes through. The configuration boards **46** along the edge **45** provide pass-through electrical paths, rather than end-around electrical paths, such that each configuration board **46** forms two links. The two links complete a loop of four module connectors. For example, the top portion of FIG. **12** logically shows the links between the two outermost module connectors of each backplane in the system **120**. The next outermost module connectors are connected in a loop in a similar manner using another configuration board **46**, and so on.

It should be understood that the module connectors **42** are linked in the X-direction in an interleaved manner. That is, the module connectors **46** of the leftmost segment of the backplane **40** are linked with the module connectors of the corresponding leftmost segment of the backplane **130**, rather than the rightmost segment in of the backplane **130**. Similarly, the module connectors **46** of the rightmost segment of the backplane **40** are linked with the module connectors of the corresponding rightmost segment of the backplane **130**, rather than the leftmost segment of the backplane **130**. Such interleaving avoids long links across the two backplanes, i.e., links between a leftmost segment of the backplane **40** and the rightmost segment of the backplane **130** are avoided. Even as the torus is expanded with many more mother boards in the X-direction, no linked modules are ever displaced by more than the combined width of a single motherboard and configuration board.

Each link **22** is formed by multiple conducting paths between the module connectors **42**. The conducting paths for each link **22** that extend across both backplanes **40** and **130** are formed by conductors in the backplane **40** and in one of the configuration boards **46**. For example, the conducting paths that form the link **122** (see FIG. **11**) extend from the module connector **27** to the module connector **132**, through the configuration board **50** along the edge **45**, as shown in FIG. **12**. In particular, a first conducting path connects a bit A of the module connector **27** and a bit A of the module connector **132**. This path includes conductor **52** of the backplane **40**, a conductor **142** of the configuration board **50**, and a conductor **136** of the backplane **130**. Similarly, a second conducting path connects a bit B of the module connector **27** and a bit B of the module connector **132**. This second path includes conductor **58** of the backplane **40**, a

conductor **144** of the configuration board **50**, and a conductor **138** of the backplane **130**.

The configuration board **50** further provides conductors that form a second link that extends between the backplanes **40** and **130**. In particular, the conducting paths that form the link **123** (see FIG. **11**) extend from the module connector **48** to the module connector **134**, through the configuration board **50** along the edge **45**, as shown in FIG. **12**. A first conducting path connects a bit C of the module connector **48** and a bit C of the module connector **134**. This path includes conductor **54** of the backplane **40**, a conductor **146** of the configuration board **50**, and a conductor **140** of the backplane **130**. Similarly, a second conducting path connects a bit D of the module connector **48** and a bit D of the module connector **134**. This second path includes conductor **60** of the backplane **40**, a conductor **148** of the configuration board **50**, and a conductor **142** of the backplane **130**.

Note that, because the direction of least significant bit to most significant bit is reversed between, for example, modules **27** and **132**, the conductor lengths remain equal to each other and independent of the position of the configuration board within the lower portion of card edge **45**. All conductors pass through the entire horizontal distance between modules. Further, the conductors pass the vertical distance from the configuration board to the corresponding connection to each module. Conductor **58** runs the full vertical distance to module **27** but the shortest vertical distance to module **132**. In the other extreme, conductor **52** runs the shortest distance to module **27** and the longest to module **132**. Other connections follow intermediate distances which, combined, approximate the length of conductors **52** and **58**.

The conductors **142**, **144**, **146** and **148** of the configuration board **50** provide pass-through electrical paths. Each configuration board **46** is adapted to provide selectively end-around electrical paths that form one link (e.g., the link **34** of FIG. **1**), and pass-through electrical paths that form two links (e.g., the links **122** and **123** of FIG. **11**). In particular, each configuration board **46** is a movable circuit board that moves between an end-around position and a pass-through position relative to the backplanes **40** and **130**. When the configuration board is in the end-around position, the end-around electrical paths are provided to the backplane **40**. When the configuration board is in the pass-through position, the pass-through electrical paths are provided to the backplanes **40** and **130** to electrically connect module connectors **42** of the backplanes together.

FIG. **13** is an edge view of a portion of the system **120** showing the backplanes **40** and **130**, the configuration board **50**, a backplate **150** and an actuator **152**. The backplate **150** holds the backplanes **40** and **130**, and the actuator **152** in fixed positions. The actuator **152** moves the configuration board **50** between the end-around and pass-through positions in response to an electrical signal received on an actuator control input **153**. In the preferred embodiment the actuator is an electric motor that drives a cam that engages in a slot in the configuration board. When the actuator control is asserted the cam rotates through 180 degrees exerting a force on the slot in the configuration board that causes the board to slide from one position to the other. A spacer assembly **156** provides structural support to separate and hold the backplane **130** in place relative to the backplate **150**. The spacer assembly **156** extends along the configuration board **50**, and includes a spring holder board **158** that holds springs **154** in place. Each spring **154** provides an electrical connection between a pad of the configuration board and a pad of a backplane when the pads are aligned. The spacer assembly **156** further separates the backplanes **40**



## 13

and **130** and the backplate **150** such that the configuration boards can move between the backplanes **40** and **130** and the backplate **150**.

Each spring **154** forms an electrical path between the configuration board and a backplane. In the preferred embodiment, each spring is constructed from a conductive beryllium spring wire wound into a circle at either end as illustrated in FIG. **13**. The spring is compressed between the backplane and the configuration board so that it exerts force against the conductive metal pads on each board. When the configuration board is moved, the spring slides along the metal pads making a wiping, gas-tight electrical contact.

It should be understood that the conductors that form the conducting paths in the configuration boards **46**, and the backplanes **40** and **130**, are formed of rigid metallic material (e.g., etch) on circuit board layers that are compressed together. The metallic material is accessed through vias and metallic pads on the surface of the configuration boards **46** and the backplanes **40** and **130**, as shown in FIG. **14**. For example, the backplane **40** includes a set of pads **162**, the backplane **130** includes a set of pads **164**, and the configuration board **46** includes multiple sets of pads **166**, **168**, **170** and **172**. The pads **162** of the backplane **40** match with a set of pads **166** on a configuration board **46**. When the configuration board **46** is positioned relative to the backplane **40** such that the pads **162** match with the pads **166**, the springs **154** (see FIG. **13**) connect the pads **162** with the pads **166** such that the configuration board **46** provides end-around electrical paths to the backplane **40**. As shown in FIG. **14**, such an alignment would provide one conducting path from pad **162f** of the backplane **40**, to pad **166f** of the configuration board **46**, through an end-around conductor **174** of the configuration board **46**, to a pad **166h** of the configuration board **46**, to a pad **162h** of the backplane **40**. Similarly, the alignment would provide another conducting path from pad **162g**, to pad **166g**, through an end-around conductor **176**, to a pad **166i**, to a pad **162i**.

The pads **162f** and **162g** (and their respective conductors within the backplane) provide differential signals and are thus positioned adjacent to each other. Similarly, pads **162h** and **162i** (and their conductors) receive differential signals and are adjacent to each other. Furthermore, conductors **182**, **184** and conductors **186**, **188** respectively carry differential signals between the two backplanes **40** and **130**.

The pads **170** and end-around conductors **178**, **180** of each configuration board **46** are optional. When available, they provide end-around connections for the second backplane **130**.

When the configuration board **46** is moved into the pass-through position by its respective actuator **152**, the configuration board **46** provides pass-through electrical paths that forms two links between the backplanes **40** and **130**. That is, the pads **168** of the configuration board **46** align with the pads **162** of the backplane **40**, and the pads **170** of the configuration board **46** align with the pads **164** of the backplane **130**. A first conducting path is formed from the pad **162f**, to the pad **168f**, through a pass-through conductor **182**, to a pad **170f**, to a pad **164f** on the backplane **130**. Similarly, other conducting paths are formed through the configuration board **46** to complete two links between the backplanes **40** and **130**.

When the configuration board **46** moves relative to the backplanes, the movement of the configuration board pads (e.g., **166**, **168**) relative to those of the backplane **40** is more controlled than that of a flexible cable end. In particular, the rigidity of the boards enable the pads of the configuration

## 14

board **46** to engage the pads of the backplane **40** with better accuracy and precision. Accordingly, the configuration board **46** can be moved (and the system topology can be changed) while the system remains powered up with minimal risk of making an incorrect electrical connection. As such, one or more modules can be added or removed prior to moving the configuration board **46** so that modules can be effectively hotswapped. As mentioned above, cabled systems can be hop-plugged as well.

Other configuration boards **46** between the two backplanes **40** and **130**, when in the pass-through positions, provide other X-direction links **22** between the backplanes **40** and **130**. Accordingly, the configuration boards **46** along the edge **45** of the backplane **40** extend the topology in the positive X-direction. Another backplane can be added along the edge **47**, i.e., the edge opposite the edge **45**, to extend the topology of the system **130** in the negative X-direction.

Similarly, other configuration boards **46** positioned along the edges **49** and **51** enable the topology to be expanded in the Y-direction. FIG. **15** shows a logical view of a multi-module data processing system **190** formed by expanding the system **20** (see FIG. **1**) in the Y-direction. The system **190** includes links **22** and modules **24** that form a three-dimensional torus arrangement. In particular, the multi-module system is a 2x4x5 arrangement.

As in the system **20**, each module **24** of the system **190** has six links which extend in six logical directions to other modules. For example, the module **26** located at the origin (the intersection of the X, Y and Z axes) has a link **28** that extends in the positive X-direction, a link **30** that extends in the positive Y-direction, a link **32** that extends in the positive Z-direction, a torus-connection link **34** that extends in the negative X-direction, a torus-connection link **192** that extends in the negative Y-direction, and a torus-connection link **38** that extends in the negative Z-direction. Similarly, the other modules have six links which extend to other modules, although for simplicity not all of the links are shown in FIG. **15**.

A module connection assembly that is suitable for the multi-module system **190** of FIG. **15** is shown in FIG. **16**. The assembly includes a first backplane **40**, a second backplane **200**, module connectors **42**, and configuration boards **46**. The backplane **200** is identical to the backplane **40**, and has the same orientation as the backplane **40**. The configuration boards **46** along the edge **51** provide pass-through electrical paths, rather than end-around electrical paths, such that each configuration board forms two links in a manner similar to that of configuration boards **46** that expand the topology in the X-direction.

It should be understood that the module connectors **42** are linked in the Y-direction in an interleaved manner. That is, the module connectors **46** of the lowest segment of the backplane **40** are linked with the module connectors of the corresponding lowest segment of the backplane **130**, rather than the uppermost segment in of the backplane **130**. Similarly, the module connectors **46** of the uppermost segment of the backplane **40** are linked with the module connectors of the corresponding uppermost segment of the backplane **130**, rather than the lowest segment of the backplane **130**. Such interleaving avoids long links across two backplanes, i.e., links between a lowest segment of the backplane **40** and the uppermost segment of the backplane **130** are avoided. Even as many backplanes are added in the Y direction, no bit of any linked module is displaced by more than the height of the backplane plus the configuration board.



Each link **22** is formed by multiple conducting paths between the module connectors **42**. The conducting paths for each link **22** that extends across both backplanes **40** and **200** are formed by conductors in the backplane **40** and a single configuration board **46**. For example, the conducting paths that form the link **192** (see FIG. **15**) extend from the module connector **27** (module **26**) to the module connector **204**, through the configuration board **202** positioned along the edge **51** of the backplane **40**, when the configuration board is in the pass-through position, as shown in FIG. **16**. In particular, a first conducting path connects a bit A of the module connector **27** and a bit A of the module connector **204**. This path includes conductor **109** of the backplane **40**, a conductor **218** of the configuration board **202**, and a conductor **210** of the backplane **200**. Similarly, a second conducting path connects a bit B of the module connector **27** and a bit B of the module connector **204**. This second path includes conductor **110** of the backplane **40**, a conductor **216** of the configuration board **202**, and a conductor **208** of the backplane **200**.

The configuration board **202**, when in the pass-through position, provides conductors that form a second link that extends between the backplanes **40** and **130**. In particular, the configuration board **202** forms conducting paths that extend from the module connector **100** to the module connector **206**, through the configuration board **202** along the edge **51**, as shown in FIG. **16**. A first conducting path connects a bit C of the module connector **100** and a bit C of the module connector **206**. This first path includes conductor **106** of the backplane **40**, a conductor **220** of the configuration board **202**, and a conductor **212** of the backplane **200**. Similarly, a second conducting path connects a bit D of the module connector **100** and a bit D of the module connector **206**. The second path includes conductor **112** of the backplane **40**, a conductor **222** of the configuration board **202**, and a conductor **214** of the backplane **200**.

The conductors **216**, **218**, **220** and **222** of the configuration board **202** provide pass-through electrical paths. Each configuration board **46** is adapted to provide selectively end-around electrical paths that form one link (e.g., the link **36** of FIG. **1**), and pass-through electrical paths that form two links (e.g., the link **192** of FIG. **15**) in a manner similar to that for the X-direction.

Each of the newly added backplanes (e.g., backplane **130** in FIG. **12**, and backplane **200** in FIG. **16**) includes configuration boards **46** positioned along its edges. When a configuration board **46** is in the end-around position, it provides end-around electrical paths that form a single link. When the configuration board **46** is in the pass-through position, it forms two links that extend between two backplanes. Additional backplanes can be added to the newly added backplanes, and so on.

It should be understood that the topologies of the systems can be expanded incrementally by moving a single configuration board **46** from its end-around position to its pass-through position, while leaving the other configuration boards in place. As a pair of modules is added to an adjacent motherboard, an end-around link is replaced by two pass-through links. Alternatively, only one complete module and a dummy module (a repeater) need to be added to maintain the full loop. The dummy module would maintain communication in the loop for redundancy without providing the processing power in a multiprocessor array for example. A subsequent expansion will then include replacing the dummy module with a standard processing module **24**. As still another alternative, only a single module could be added, thus breaking that loop. The remainder of the net-

work would, however, remain intact. When all of the configuration boards **46** between two backplanes are in their pass-through positions, the two backplanes are fully linked with each other in a complete torus. At this point, any further topology expansion requires the addition of another backplane, and the switching of a configuration board along a different edge.

A physical view of a complete single backplane system **230** is shown in FIG. **17A**. The system **230** includes control circuitry **232** and a processing structure **234**. The control circuitry **232** includes maintenance circuitry for monitoring system conditions, configuration circuitry that provides actuator control signals to change the configuration of the processing structure **234**, and other overhead features such as startup programs, diagnostics, and reset circuitry. The processing structure **234** includes a system such as that shown in FIG. **2** that is populated with modules. Cables connect the control circuitry **232** with the processing structure **234**, to enable communication between the control circuitry **232** and the processing structure **234**. Such communication is generally at a lower bandwidth than that used between modules **24** of the processing structure **234**.

The system **230** is expandable in the Y-direction to form a larger system **236**, as shown in FIG. **17B**. Here, another backplane has been added to the single backplane processing structure **234**, and one or more configuration boards **46** has been switched to its pass-through position to form links between the two backplanes to form a larger processing structure **238**.

Alternatively, the system **230** is expandable in the X-direction to form a larger system **240**, as shown in FIG. **17C**. Here, another backplane has been added to the single backplane processing structure **234**, and one or more configuration boards **46** has been switched to its pass-through position to form links between the two backplanes to form a larger processing structure **242**.

Furthermore, the system **230** is expandable in multiple directions, as shown in FIG. **17D**. Here, the system **230** is expanded in both the X and Y-directions by adding multiple backplanes in both directions to form a larger processing structure **244**. As shown, the processing structure **244** is extended in the Y-direction by two arrays of backplanes **246** and **248**. In particular the array of backplanes **248** is positioned behind the array of backplanes **246**. The processing structure is extendable in this manner in the X-direction as well.

The system **230** includes special backplanes **252a**, **252b** and flexible extenders **250** to link the arrays **246** and **248**. In FIG. **17D**, the flexible extenders **250** are shown looping over from one backplane array to another, and may appear relatively long in length. However, it should be understood that the lengths of the extenders **250** can be kept short, and should be kept short to minimize propagation delays. Each special backplane **252** includes two row segments **44** of module connectors **42** rather than four (see FIG. **2**). As such, a pair of special backplanes **252a**, **252b** and a flexible extender **250** provide equivalent electrical connections as that of the backplane **40** in FIG. **2**. Use of this special assembly is convenient when space (e.g., computer room wall space or floor space) is limited. As shown in FIG. **17D**, the bottom row of backplanes can be formed by half-backplanes **254**. Accordingly, each array may include two rows of half-backplanes, one at the top and one at the bottom, such that each array is an even number of half-backplanes in length in the vertical direction (e.g., four half-backplanes).



## Equivalents

While this invention has been particularly shown and described with references to preferred embodiments thereof, it will be understood by those skilled in the art that various changes in form and details may be made therein without departing from the spirit and scope of the invention as defined by the appended claims. Those skilled in the art will recognize or be able to ascertain using no more than routine experimentation, many equivalents to the specific embodiments of the invention described specifically herein. Such equivalents are intended to be encompassed in the scope of the claims.

For example, it should be understood that the actuators **152** that move the configuration boards **46** may be electric motors. Each actuator and corresponding configuration board are considered to be a configuration controller since they can change the topology of the system. The actuators alternatively may be non-motorized devices such as mechanically operated lever or gear mechanisms.

Additionally, electronic switches may be substituted for the configuration boards **46** such that the end-around and pass-through electrical paths are provided by electrical switching rather than by mechanical switching.

Furthermore, the module arrangements are not limited to expansion in three dimensions. Rather, the module arrangements can be expanded in more or fewer dimensions by arranging the conducting paths within the backplanes to connect the module connectors **42** accordingly.

The remotely configurable interconnection described here is not limited to regular mesh or torus network topologies but can be applied to arbitrary network topologies. The network may be a multistage network such as a butterfly, a non-blocking network such as a Batcher, Benes, or Clos network, a tree network, or even an arbitrary irregular connection of modules and links. In each case, individually actuated configuration controllers can be used to incrementally extend the network.

What is claimed is:

**1.** A module connection assembly, comprising:

a plurality of backplanes;

a plurality of sets of module connectors, each set of module connectors being capable of electrically connecting modules to a different one of the plurality of backplanes; and

configuration conductors providing rigid metallic conductor paths between module connectors on different backplanes;

the plurality of backplanes and the configuration conductors providing a plurality of links which electrically connect the plurality of sets of module connectors in a logical torus having multiple dimensions, each link including a cableless electrical signal path formed exclusively of rigid metallic material.

**2.** The module connection assembly of claim **1** wherein the configuration conductors provide:

a plurality of switches that are remotely controlled to electrically connect the plurality of sets of module connectors in the logical torus.

**3.** The module connection assembly of claim **1** wherein the logical torus is three dimensional.

**4.** The module connection assembly of claim **1** wherein each cableless electrical path in a particular dimension has substantially the same length.

**5.** The module connection assembly of claim **1** wherein each cableless electrical path in a particular dimension includes bit paths having substantially the same lengths.

**6.** The module connection assembly of claim **1** wherein each given backplane of the plurality of backplanes electrically connects one of the sets of module connectors in an interleaved manner.

**7.** The module connection assembly of claim **6** wherein the module connectors of the one set are disposed physically in row segments on the given backplane, and wherein the given backplane electrically connects the row segments in an interleaved manner.

**8.** The module connection assembly of claim **6** wherein the module connectors of the one set are disposed physically in row segments on the given backplane, and wherein the given backplane structure electrically connects the module connectors of the one set within each row segment in an interleaved manner.

**9.** The module connection assembly of claim **6** wherein the module connectors of the one set are disposed physically in row segments on the given backplane; wherein the row segments are disposed physically on the given backplane in a two dimensional array; and wherein the given backplane electrically connects the row segments in an interleaved manner and electrically connects the module connectors of the one set within each row segment in an interleaved manner such that the given backplane electrically connects the one of the sets of module connectors in an interleaved manner in three dimensions.

\* \* \* \* \*

UNITED STATES PATENT AND TRADEMARK OFFICE  
**CERTIFICATE OF CORRECTION**

PATENT NO. : 6,976,064 B2  
DATED : December 13, 2005  
INVENTOR(S) : Philip P. Carvey, William J. Dally and Larry R. Dennison

Page 1 of 1

It is certified that error appears in the above-identified patent and that said Letters Patent is hereby corrected as shown below:

Column 18,  
Line 33, delete "structure".

Signed and Sealed this

Twenty-first Day of February, 2006

A handwritten signature in black ink on a light gray dotted background. The signature reads "Jon W. Dudas" in a cursive style.

JON W. DUDAS

*Director of the United States Patent and Trademark Office*