



US006972087B2

(12) **United States Patent**  
**Wolford et al.**

(10) **Patent No.:** **US 6,972,087 B2**  
(45) **Date of Patent:** **\*Dec. 6, 2005**

(54) **TRANSMISSION SUMP FILTER WITH BYPASS VALVE**

(75) Inventors: **James B. Wolford**, Chicago, IL (US);  
**Mitch Kujawski**, Des Plaines, IL (US);  
**Morgan Bullard**, Palatine, IL (US);  
**John E. Szydlo**, Brookfield, IL (US);  
**Yakov Sarnov**, Morton Grove, IL (US)

(73) Assignee: **SPX Corporation**, Charlotte, NC (US)

(\*) Notice: Subject to any disclaimer, the term of this patent is extended or adjusted under 35 U.S.C. 154(b) by 0 days.

This patent is subject to a terminal disclaimer.

(21) Appl. No.: **10/431,363**

(22) Filed: **May 8, 2003**

(65) **Prior Publication Data**  
US 2003/0201216 A1 Oct. 30, 2003

**Related U.S. Application Data**  
(63) Continuation of application No. 09/870,172, filed on May 30, 2001, now Pat. No. 6,582,593.

(51) **Int. Cl.**<sup>7</sup> ..... **B01D 35/147**  
(52) **U.S. Cl.** ..... **210/130; 210/132; 210/149; 210/168; 210/171; 210/416.5; 210/445; 210/455**  
(58) **Field of Search** ..... **210/130-133, 210/149, 168, 172, 416.5, 420, 445, 452, 210/455, 486, 171; 168/6.24, 106; 184/6.24, 184/106; 137/540, 543.17, 543.21, 543.23, 137/550**

(56) **References Cited**

**U.S. PATENT DOCUMENTS**

2,448,212 A	8/1948	Dewey	
2,782,934 A *	2/1957	Maysilles	210/130
3,056,501 A	10/1962	Thorman et al.	
3,297,162 A	1/1967	Mouwen	
3,397,786 A	8/1968	Hultgren	
4,129,503 A	12/1978	Joseph	
4,446,017 A	5/1984	Oberg	
4,450,581 A	5/1984	Hirata	
4,689,144 A	8/1987	Holmes	
4,766,930 A *	8/1988	Patti	137/540
4,783,271 A	11/1988	Silverwater	
5,863,424 A	1/1999	Lee	
6,582,593 B2 *	6/2003	Wolford et al.	210/130

**FOREIGN PATENT DOCUMENTS**

JP 2-78408 3/1990

\* cited by examiner

*Primary Examiner*—Matthew O. Savage  
(74) *Attorney, Agent, or Firm*—Baker & Hostetler LLP

(57) **ABSTRACT**

A filter (10) for filtering debris out of the fluid in a transmission sump (S) prior to the fluid entering a transmission pump (P) is disclosed. The filter (10) includes a filter housing (12) presenting a filter inlet (30), a bypass inlet (32), and an outlet (46). Filter media (14) is disposed in the housing (12) such that fluid flowing from the filter inlet (30) to the outlet (46) passes through the media (14) and fluid flows from the bypass inlet (32) to the outlet (46) without passing through the media (14). A bypass valve assembly (16), shiftable into and out of a closed position, prevents fluid flow through the bypass inlet (32) when the valve (16) is closed.

**46 Claims, 4 Drawing Sheets**

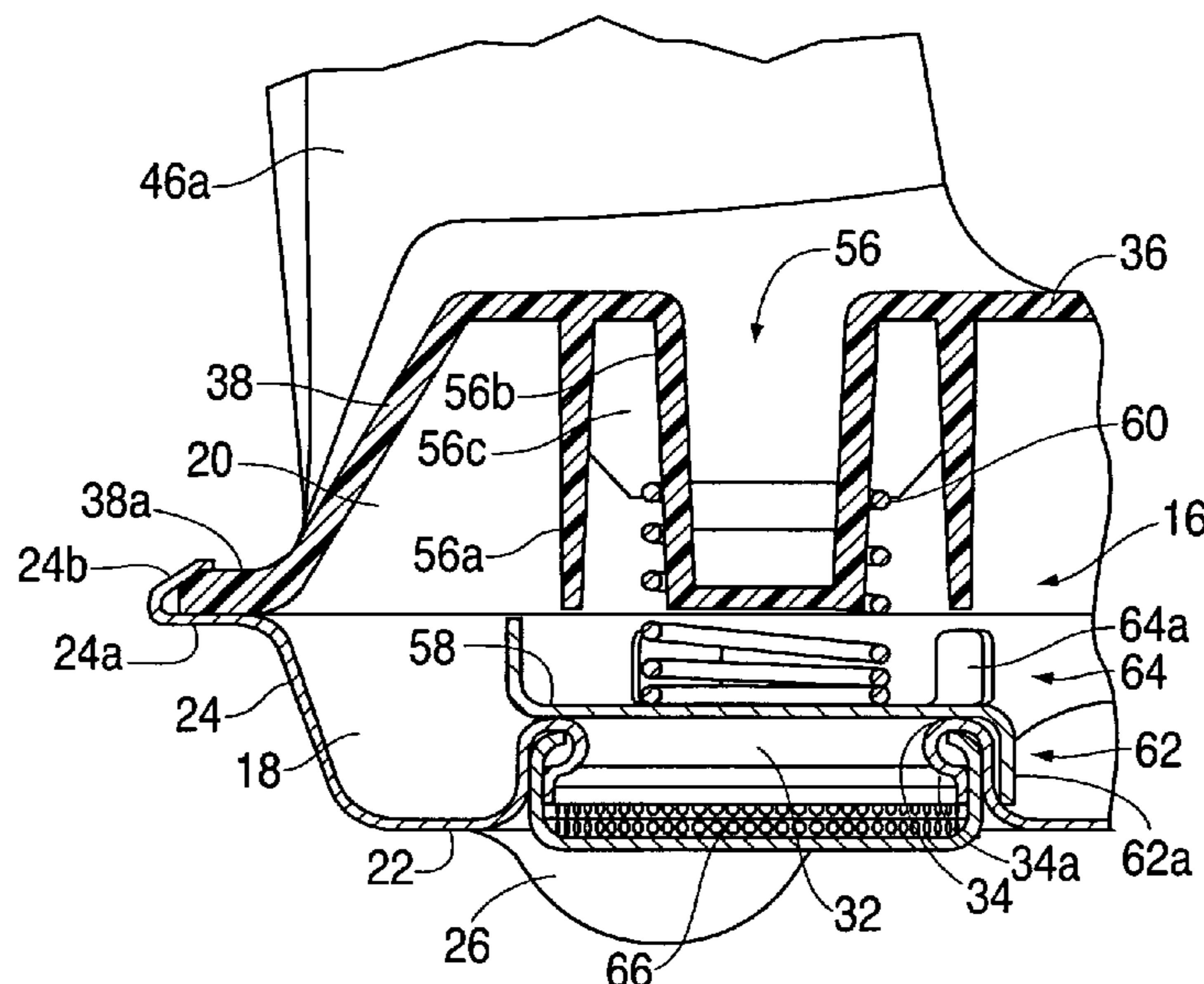

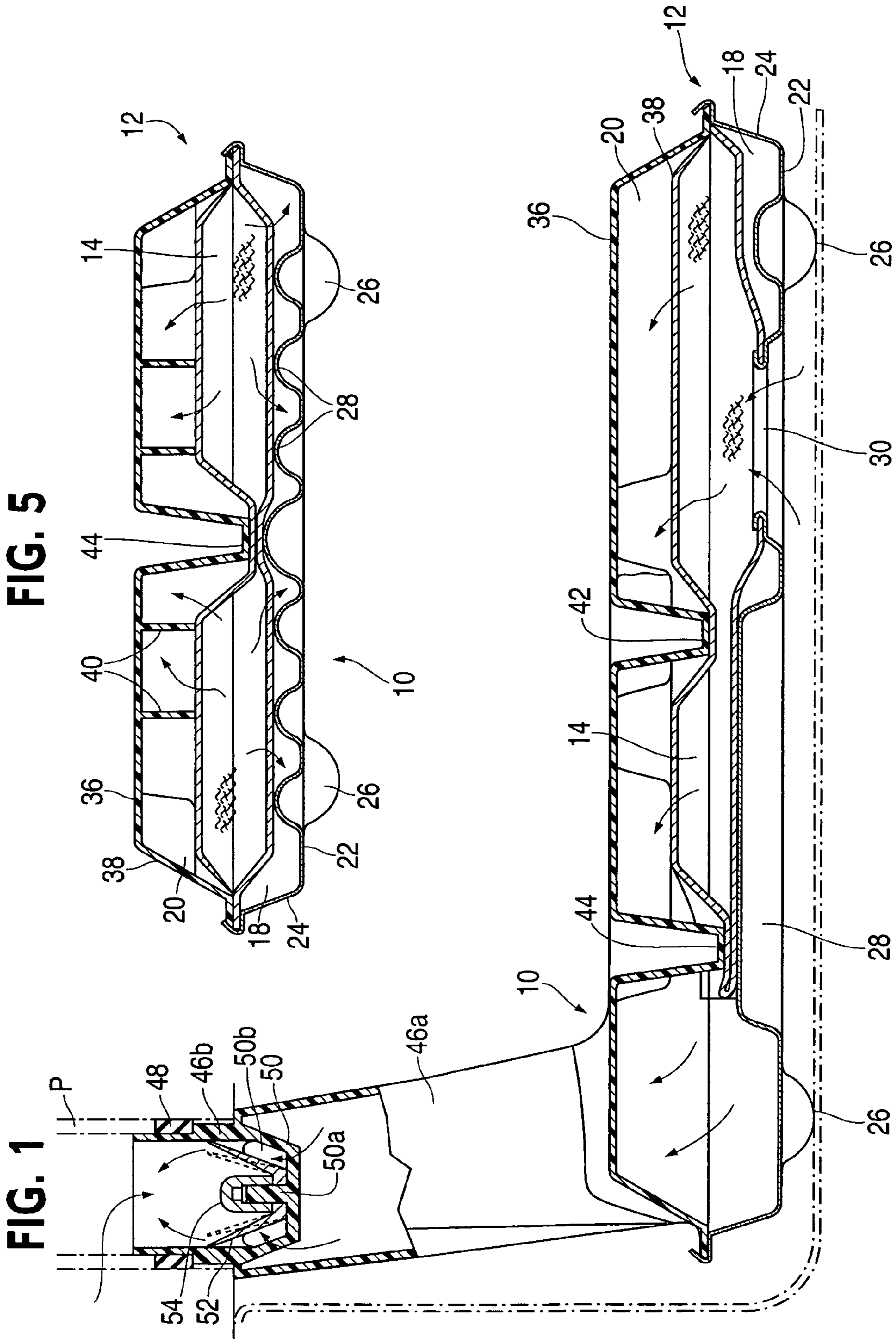

FIG. 5

FIG. 1

FIG. 2

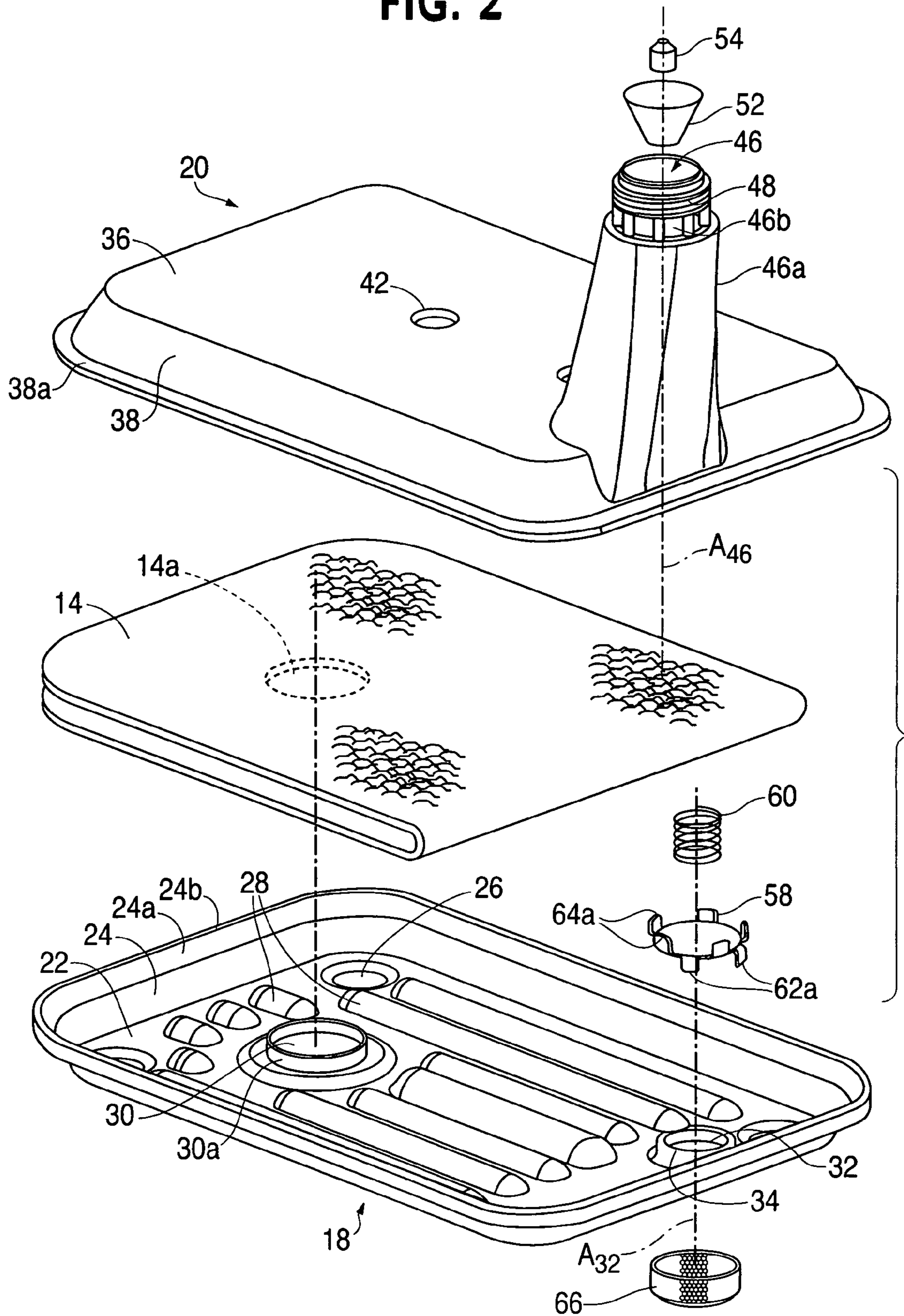



FIG. 3

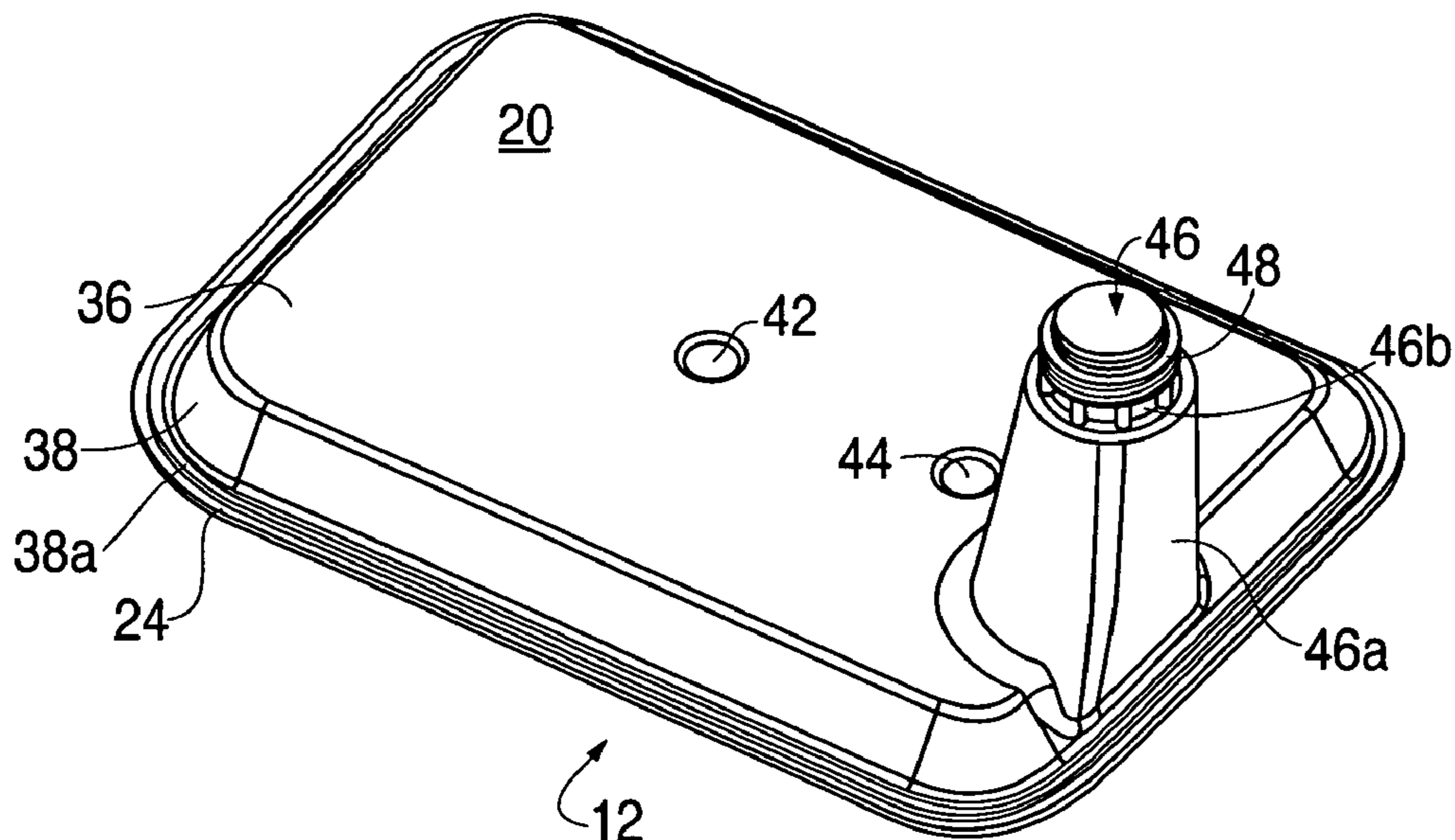

FIG. 4

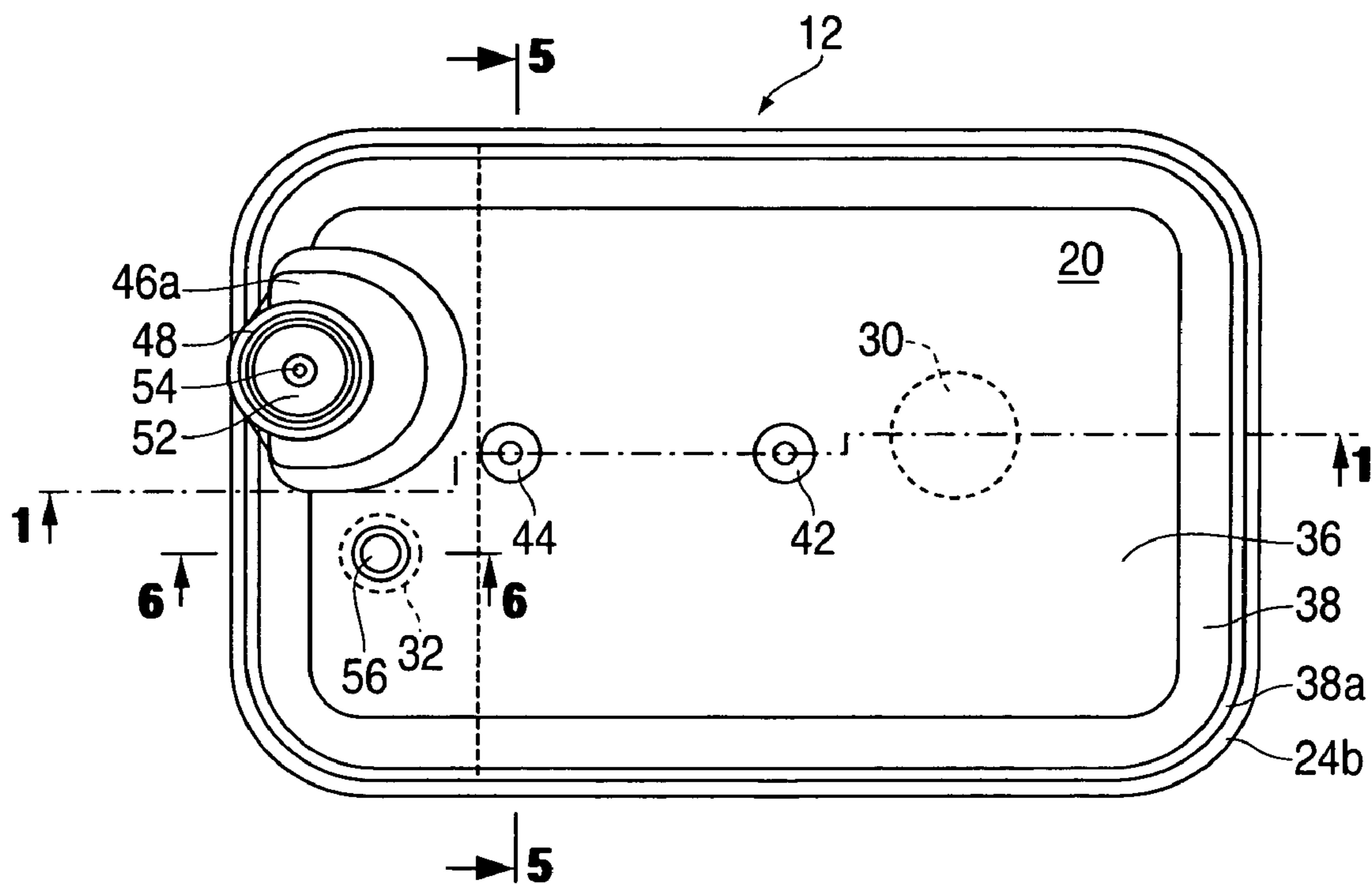

FIG. 6

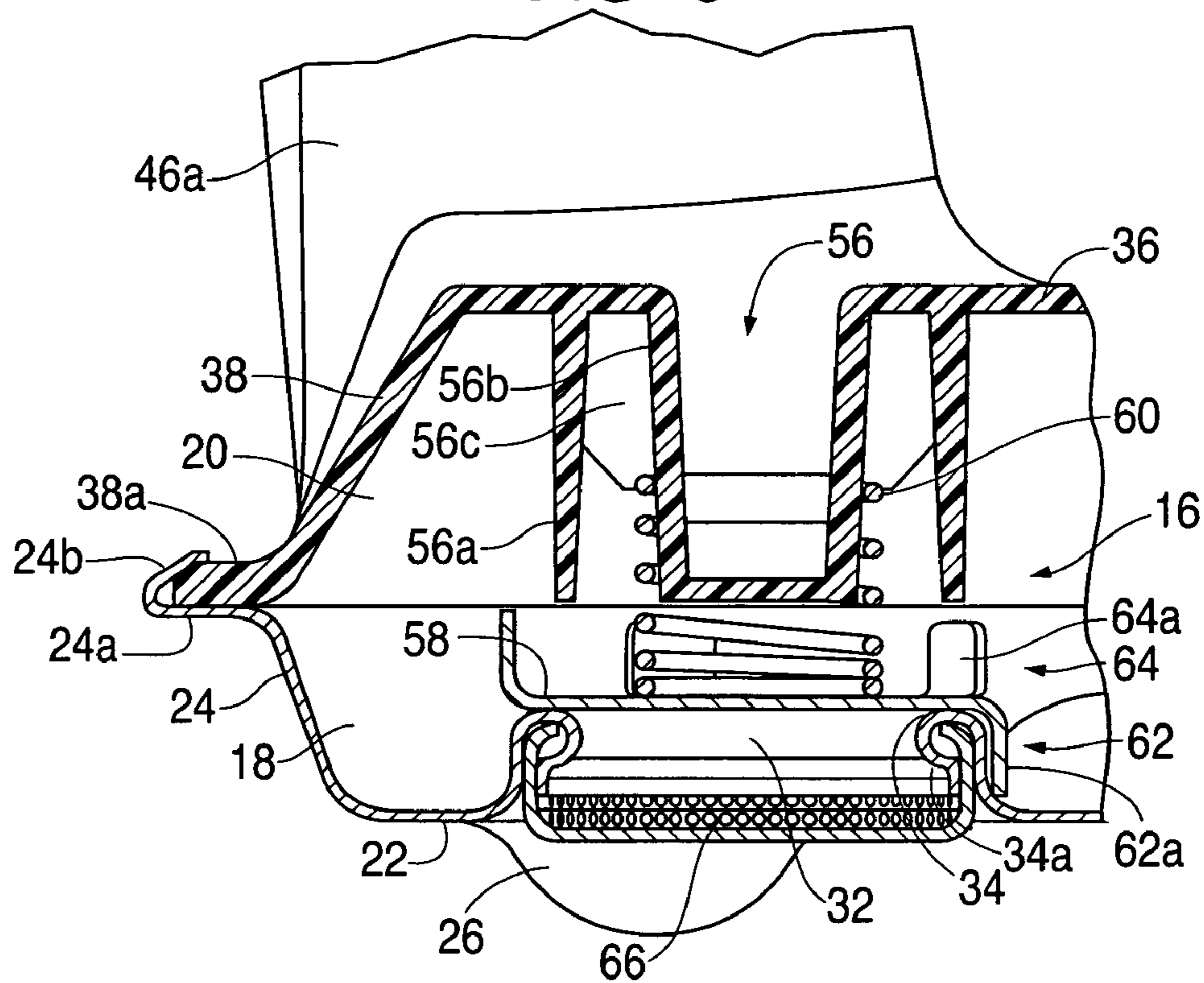
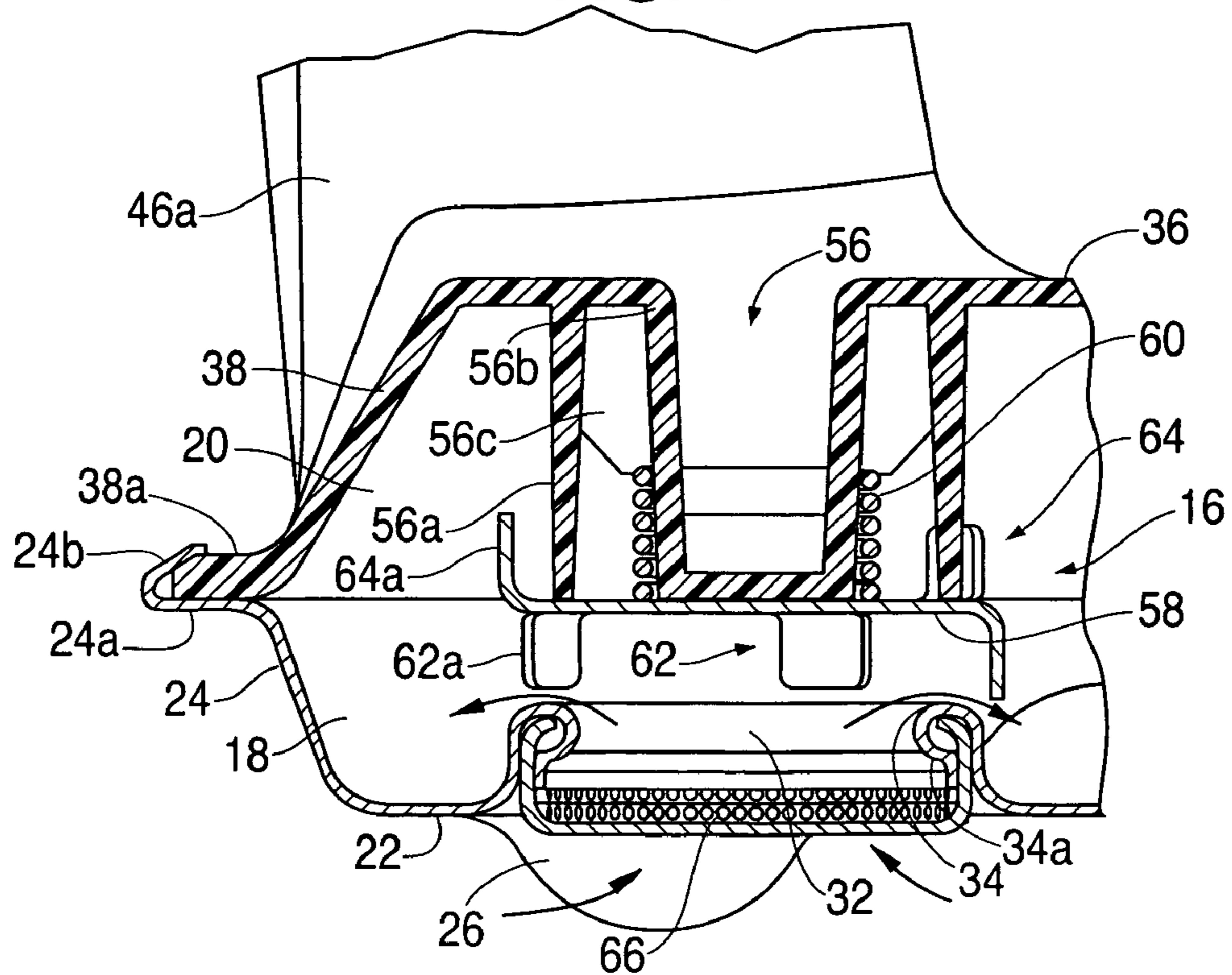

FIG. 7





1

## TRANSMISSION SUMP FILTER WITH BYPASS VALVE

This application is a continuation of U.S. patent applica-  
tion Ser. No. 09/870,172, filed May 30, 2001, now U.S. Pat. 5  
No. 6,582,593, which is incorporated herein by reference.

### BACKGROUND OF THE INVENTION

#### 1. Field of the Invention

The present invention relates generally to transmission  
sump filters for powered vehicles. More specifically, the  
present invention concerns a transmission fluid filter having  
a uniquely configured bypass valve that operates to effi-  
ciently and effectively direct fluid to a transmission pump  
without passing it through a filter media in conditions when  
bypass is desirable (e.g., cold and start-up conditions).

#### 2. Discussion of Prior Art

In a powered vehicle having a lubricated transmission, it  
is desirable to filter debris (e.g., solid particles, impurities,  
etc.) out of the fluid in the transmission sump prior to the  
fluid entering the transmission pump. Known prior art filters  
utilize a porous filter media fluidly interposed between the  
sump and the pump to filter the fluid. Unfortunately, these  
prior art filters are problematic because in certain conditions  
(e.g., cold and start-up conditions), the fluid is not-ade-  
quately sucked through the filter media (e.g., the fluid is too  
viscous) and thus fluid is not sufficiently provided to the  
pump.

Some prior art filters utilize a bypass valve to bypass the  
filter media during these conditions when bypass is desired.  
These prior art filter bypass valves; however, are problem-  
atic in that they are costly to construct, unreliable, and  
ineffective and inefficient in providing sufficient fluid to the  
pump during bypass conditions.

### SUMMARY OF THE INVENTION

The present invention provides an improved filter that  
does not suffer from the problems and limitations of prior art  
filters set forth above. The inventive filter provides a bypass  
valve that reliably operates when bypass is desired, reliably  
closes when bypass is not desired, and effectively and  
efficiently provides fluid to the pump when in operation. The  
inventive filter further provides a bypass valve that is simple  
and inexpensive to construct.

A first aspect of the present invention concerns a filter  
broadly including a filter housing presenting a filter inlet, a  
bypass inlet, and an outlet; filter media in the housing such  
that fluid flowing from the filter inlet to the outlet passes  
through the media and fluid flows from the bypass inlet to  
the outlet without passing through the media; and a bypass  
valve assembly shiftable into and out of a closed position in  
which fluid flow through the bypass inlet is prevented. The  
bypass inlet is defined about a bypass inlet axis and the  
outlet is defined about an outlet axis, wherein the axes are at  
least substantially parallel and at least in close proximity to  
one another.

A second aspect of the invention concerns a filter wherein  
the bypass valve assembly includes a projecting valve seat  
and a valve body shiftable in a first direction into and out of  
sealing engagement with the valve seat. The valve body  
includes a first positioning element extending toward the  
valve seat and cooperating therewith to restrict movement of  
the valve body in a second direction, wherein the first and  
second directions are at least generally unparallel to one  
another.

2

A third aspect of the present invention concerns a filter  
wherein the bypass valve assembly further includes a lug  
operable to limit the range of movement of the valve body  
in the first direction to a path and the valve body is  
configured to cooperate with the lug and the valve seat to  
restrict, along the entire path, movement of the valve body  
in the second direction.

A fourth aspect of the present invention concerns a filter  
wherein the bypass valve assembly broadly includes a  
biasing mechanism yieldably biasing the assembly into the  
closed position. The mechanism is configured so that the  
yieldable biasing force provided thereby varies depending  
on temperature.

Other aspects and advantages of the present invention will  
be apparent from the following detailed description of the  
preferred embodiment and the accompanying drawing fig-  
ures.

### BRIEF DESCRIPTION OF THE DRAWING FIGURES

A preferred embodiment of the invention is described in  
detail below with reference to the attached drawing figures,  
wherein:

FIG. 1 is a cross-sectional view, taken substantially along  
line 1—1 of FIG. 4, of a filter constructed in accordance with  
a preferred embodiment of the present invention and shown  
in combination with a transmission sump and pump;

FIG. 2 is an exploded side perspective view of the filter;

FIG. 3 is a top perspective view of the filter;

FIG. 4 is a top plan view of the filter;

FIG. 5 is a cross-sectional view of the filter taken sub-  
stantially along line 5—5 of FIG. 4 illustrating the general  
direction of fluid flow;

FIG. 6 is a fragmentary cross-sectional view of the filter  
taken substantially along line 6—6 of FIG. 4 illustrating the  
valve assembly in the closed position with the valve body in  
sealing engagement with the valve seat; and

FIG. 7 is a fragmentary cross-sectional view similar to  
FIG. 6 illustrating the valve assembly fully open with the  
valve body engaging the lug.

### DETAILED DESCRIPTION OF THE PREFERRED EMBODIMENT

FIG. 1 illustrates a filter 10 constructed in accordance  
with a preferred embodiment of the present invention, at  
least partially submerged in a fluid-filled transmission sump  
S and fluidly interposed between the sump S and a trans-  
mission pump P (having a pump inlet) of a lubricated  
transmission system of a powered vehicle. The filter 10 is  
configured for filtering debris (e.g., solid particles, impuri-  
ties, etc.) out of the fluid before it enters the pump inlet of  
the pump P. The inventive filter is particularly suited for use  
in the transmission system of an automobile; however, the  
inventive filter could be utilized in virtually any lubricated  
transmission system utilizing a sump and a pump (e.g., a  
powered machine), as well as any type of powered vehicle  
(e.g., airplane, boat, motorcycle, tractor, etc.). The illustrated  
filter 10 broadly includes a filter housing 12, a filter media  
14 disposed within the housing 12, and a bypass valve  
assembly 16 associated with the housing 12 and spaced from  
the media 14 (see FIGS. 1 and 2).

Turning to FIG. 2, the filter housing 12 is a dual-body  
housing including a stamped metal tray section 18 and a  
molded plastic hood section 20 (see FIG. 2) that coopera-  
tively define a filter chamber therebetween. The tray section



18 has a unitary construction with a generally rectangular shape having a bottom wall 22 and a contiguous side wall 24 angularly extending from the bottom wall 22. Formed in the bottom wall 22 at the four corners are sump legs 26 extending opposite the open face of tray section 18. The sump legs 26 are configured to support the filter 10 on the inside surface of the sump S and provide adequate clearance therefrom so the filter 10 remains at least partially submerged in fluid but allows the fluid to be drawn into the filter 10 as shown in FIG. 1. Formed in the bottom wall 22 along the surface are tray baffles 28 extending toward the open face of the tray section 18. The baffles 28 are spaced from one another to provide fluid channels therebetween (see FIG. 2) with the center baffle projecting further into the filter chamber than the other baffles (see FIG. 5). For purposes that will subsequently be described, the baffles 28 span a length of the bottom wall 22 proportionate to the length of the filter media 14; however, the proportionate length is less than the entire length of the bottom wall 22. The baffles 28 support the filter media 14 so that the media 14 remains out of the fluid channels and fluid is free to flow through the fluid channels after exiting the media 14.

Formed in the bottom wall 22 generally at the distal end (relative to the pump inlet of the pump P) is a filter inlet 30. The filter inlet 30 is a circular aperture having a crimpable collar 30a that extends into the filter chamber. Spaced from the filter inlet 30 and formed in the bottom wall 22 generally at the proximal end (relative to the pump inlet of the pump P) is a bypass inlet 32. The bypass inlet 32 is a circular aperture and for purposes that will subsequently be described includes a projecting valve seat 34 extending into the filter chamber and a crimpable collar 34a concentric to the projecting valve seat 34 (see FIG. 7). The location of the bypass inlet 32 relative to the filter inlet 30 could be variously designed; however, it is important that the filter inlet 30 is laterally spaced from the bypass inlet 32 and located in the portion of the bottom wall 22 having the baffles 28 (and therefore contiguous with the media 14) and the bypass inlet 32 is located in the portion without the baffles 28 (and therefore non-contiguous with the media 14).

The side wall 24 extends from the bottom wall 22 toward the open face of the tray section 18 and includes a rib-receiving lipped portion 24a and a crimpable rib-securing flanged portion 24b formed in the side wall 24 (see FIGS. 1 and 2). The lipped portion 24a is generally parallel to the bottom wall 22 and extends outward from the filter chamber. The flanged portion 24b is generally perpendicular to the lipped portion 24a extending away from the bottom wall 22 prior to assembly of the filter 10 (see FIG. 2).

The hood section 20 has a unitary construction with a generally rectangular shape complementary to the shape of the tray section 18 (generally a mirror image thereto) having a top wall 36 and a contiguous side wall 38 angularly extending from the top wall 36 (see FIG. 3). Formed in the top wall 36 along the surface are hood baffles 40 extending toward the open base of the hood section 20. The baffles 40 are spaced from one another to provide fluid channels therebetween (see FIG. 5). For purposes that will subsequently be described, the baffles 40 span a length of the top wall 36 proportionate to the length of the filter media 14; however, the proportionate length is less than the entire length of the top wall 36. The baffles 40 detain the filter media 14 so that the media 14 remains out of the fluid channels and fluid is free to flow through the fluid channels after passing through the media 14.

Formed in the top wall 36 are distal and proximate frustoconical projections 42,44, respectively (see FIG. 1).

The projections 42,44 are disposed generally along the longitudinal center axis of the hood section 20 (see FIG. 4) and configured to prevent the filter 10 from deforming or collapsing (e.g., during start-up conditions where the suction forces exerted by the pump P are relatively high and the flow of fluid through the media 14 is relatively low). The distal projection 42 is generally located near the geometric center of the top wall 36. The proximate projection 44 is located at or near the demarcation between the baffled portion and the non-baffled portion of the top wall 36. As will subsequently be described in detail, the proximate projection 44 is configured so that it also cooperates with the center tray baffle 28 to serve as a pinch-point that prevents the media 14 from being undesirably suctioned into any of the relevant channels of fluid flow (see FIG. 5).

Formed in the non-baffled portion of the top wall 36 (generally at the proximal end relative to the pump inlet of the pump P) is a filter outlet 46. The filter outlet 46 includes a circular aperture in the top wall 36 and a neck portion 46a thereabove and extending outward from the top wall 36 away from the filter chamber. The neck 46a is configured to be fluidly connected to the pump inlet of the pump P (see FIGS. 1 and 2). In this regard, the terminal end of the neck 46a includes a recessed, ribbed collar 46b with an O ring-type gasket 48 coupled thereto (see FIG. 2). The filter 10 is configured to prime the pump P and in this regard, integrally formed inside the terminal end of the neck 46a is a well housing 50 having a receiver stem 50a and a plurality of fluid inlets 50b (see FIG. 1). A flexible cone-shaped primer valve 52 is configured to fit over the receiver stem 50a and be received in the well housing 50 (see FIGS. 1 and 2). The primer valve 52 is held in place by a cap 54 coupled to the receiver stem 50a (e.g., ultrasonically welded thereto). When the filter 10 is in operation, suction force from the pump P opens the flexible primer valve 52 (as shown in phantom lines in FIG. 1) allowing fluid to exit the filter 10 through the fluid inlets 50b into the pump inlet of the pump P (see FIG. 1). When the filter 10 is not in operation (and the suction force provided by the pump P is terminated) the flexible primer valve 52 closes (as shown in solid lines in FIG. 1) and fluid is retained in the pump P so that the pump P remains primed. The primer valve 52 is formed of a suitable material that provides the valve 52 with its flexible capabilities, with one suitable material being a polymer available from Dupont, P.O. Box 80026, Wilmington, Del. 19880-0026, under the registered mark VAMAC.

The filter outlet 46 and the bypass inlet 32 are each defined about a respective axis  $A_{46}, A_{32}$  (see FIG. 2) that is generally perpendicular to the bottom and top walls 22,36. The axes  $A_{46}$  and  $A_{32}$  are substantially parallel to each other. The filter outlet 46 is positioned so that the axes  $A_{46}$  and  $A_{32}$  are at least in close proximity to one another so that fluid flowing from the bypass inlet 32 to the filter outlet 46 travels in a substantially straight linear path. Ideally, the filter outlet 46 and the bypass inlet 32 would be coaxial; however, tooling constraints have limited the illustrated filter 10 to the close proximity axial arrangement shown in the drawing figures.

Formed in the non-baffled portion of the top wall 36 and complementally opposed to the valve seat 34 and extending theretowards is a lug 56 (see FIG. 6). For purposes that will subsequently be described, the lug 56 includes an outer cylindrical sheath section 56a and an inner stepped frustoconical lug section 56b having ribbing 56c.

The side wall 38 extends from the top wall 36 toward the open base of the hood section 20 and includes a crimping rib 38a (see FIGS. 1 and 2). The rib 38a is generally parallel to



the top wall **36** and extends outward from the filter chamber. The rib **38a** is configured to be received in the rib-receiving lipped portion **24a** of the tray section **18** and secured in place by crimping the flanged portion **24b** thereto (see FIG. 5).

The filter housing could utilize various alternative designs, constructions and materials. For example, the housing could be variously shaped to correspond to the particular application to fit between a specific sump and pump. The housing need not utilize a dual-body construction, nor utilize any particular materials or methods of joining the same. It is important; however, that the filter and bypass inlets and the filter outlet are configured such that fluid flowing from the bypass inlet to the filter outlet flows along a generally linear path that does not pass through the filter media and that the filter inlet be spaced from the bypass inlet and that fluid flowing from the filter inlet to the filter outlet passes through the filter media.

The filter media **14** is disposed in the filter chamber within the filter housing **12** and filters debris out of the fluid flowing from the filter inlet **30** to the filter outlet **46**. The filter media **14** is formed of a suitable material having filtering qualities and is configured to cooperate with the filter housing **12** to form a filter bag around the filter inlet **30**. In this regard, the media **14** is preferably in the form of a flexible material sheet having an aperture **14a** positioned to receive the filter inlet collar **30a** (see FIG. 2). The filter sheet is placed in the tray section **18** with the aperture **14a** positioned over the collar **30a** and the collar **30a** is crimped over the sheet to hold the media **14** in place (see FIG. 1). The sheet is then doubled over (forming the bag) so that the fold-line is located at or near the demarcation between the baffled portion and the non-baffled portion of the filter housing **12** (see FIGS. 1 and 2). The distal end (relative to the fold-line) and the sides of the of the filter bag are formed by pinching the folded sheet between the crimping rib **38a** and the flange **24b** of the side walls of the filter housing **12** (see FIGS. 1 and 5). The filter media **14** is further secured by the pinch point provided by the cooperation of the projection **44** with the center tray baffle **28** (see FIG. 5), and retained out of the fluid channels by the projections **42,44** (see FIG. 1).

Fluid flowing from the sump **S** through the filter inlet **30** passes through the filter media **14**, where debris is filtered out of the fluid, then into the fluid channels and out through the filter outlet **46** into the pump inlet of the pump **P** (see FIGS. 1 and 5). Fluid flowing from the sump **S** through the bypass inlet **32**; however, does not pass through the filter media **14** but rather flows directly to the filter outlet **46** (see FIG. 7). The fluid is drawn into the filter **10** by the suction force created by the pump **P**.

The filter media could be formed of various materials and utilize any workable design and configuration so long as fluid flowing from the filter inlet is filtered by the media before exiting the filter outlet and fluid flowing from the bypass inlet does not pass through the media before exiting the filter outlet.

Under normal conditions (e.g., ambient temperatures above  $-18$  degrees Celsius) the viscosity of the fluid is such that the fluid is adequately drawn through the filter media and into the pump. During conditions other than normal (e.g., cold conditions where the ambient temperature is below  $-40$  degrees Celsius) the viscosity of the fluid is such that the fluid is not adequately drawn through the filter media (e.g., the viscosity of the fluid resembles toothpaste) and therefore sufficient fluid is not provided to the pump. It is therefore desirable to bypass the filter media during condi-

tions other than normal. Accordingly, the filter **10** includes means for bypassing the filter media **14** when bypass is desired.

In the illustrated filter **10**, this desired bypass is provided by the bypass valve assembly **16**. The valve assembly **16** broadly includes a valve body **58** and a spring **60** coupled between the coaxially aligned projecting valve seat **34** and opposing lug **56** (see FIGS. 2 and 6). The valve body **58** is a circular shaped flat disk having a first positioning element **62** and a second positioning element **64**. The element **62** comprises a plurality of circumferentially spaced seat tabs **62a** extending from the edge of the body **58** toward the valve seat **34**. The valve body **58** and the valve seat **34** are configured to provide engagement therebetween when the valve **16** is in a closed position as shown in FIG. 6. Particularly, the spring **60** presses the disk against the seat **34** with enough force that during normal operating conditions, the flow path of least resistance is through the filter media **14**. The valve assembly **16** is shiftable along a first direction into and out of the closed position, wherein the first direction is generally parallel to the axis common to both the seat **34** and the lug **56** so that the body **58** is aligned therebetween. The first positioning element **62** is configured to allow the sealing engagement of the body **58** with the seat **34** and cooperate with the seat **34** to restrict movement of the body **58** in a second direction. The first and second directions are at least generally unparallel to one another and movement of the body **58** in the second direction results in misalignment of the body **58** with the seat **34**. Movement of the body **58** in the second direction is restricted by circumscribed engagement of the seat tabs **62a** with the circumferential surface of the projecting seat **34**.

The second positioning element **64** comprises a plurality of circumferentially spaced lug tabs **64a** extending from the edge of the body **58** toward the lug **56**. The valve body **58** and the lug **56** are configured to provide aligned engagement therebetween when the valve **16** is in a fully open position as shown in FIG. 7. The lug **56** serves as a stop to limit the range of movement of the body **58** along the first direction to thereby define a path. In operation, the body **58** oscillates along this path, shifting to and from the fully open and closed positions. The second positioning element **64** is configured to allow the aligned engagement of the body **58** with the lug **56** and cooperate with the lug **56** to restrict movement of the body **58** in the second direction. Movement of the body **58** in the second direction is restricted by circumscribed engagement of the lug tabs **64a** with the outer circumferential surface of the sheath section **56a** of the lug **56**.

The seat and lug tabs **62a,64a** are dimensioned so that movement of the body **58** in the second direction is restricted along the entire path of movement. Although the tabs **62a,64a** that restrict movement in the second direction will change as the body **58** shifts from the closed position to the fully open position and back, either the seat tabs **62a** or the lug tabs **64a** will be in engagement with the respective seat **34** or lug **56** at all times as the body **58** oscillates along the path. To facilitate manufacturing, the tabs **62a,64a** are offset along the circumference of the disk and unitary therewith (e.g., the tabbed disk is stamped out of metal and the tabs are then folded into position).

Once bypass conditions no longer exist during operation (e.g., after start-up or after the fluid achieves a temperature that adequately reduces the viscosity), it is desirable to prevent bypass so that fluid flows through the media **14** and is thoroughly filtered. In this regard, the bypass valve assembly **16** of the illustrated filter **10** is yieldably biased



into the closed position by the spring **60** (see FIG. 6). The yieldable biasing force provided by the spring **60** is such that in cold conditions (e.g., -40 degrees Celsius or below) the suction force of the pump P (and corresponding differential pressure across the valve **16**) overcomes the biasing force of the spring **60** (thereby opening the bypass valve **16**), but in normal conditions (e.g., -18 degrees Celsius or above) the biasing force of the spring **60** overcomes the suction force of the pump P (thereby closing the valve **16**). The spring **60** can be formed from any suitable material that provides the desired yieldable biasing capabilities, with a preferred material being cold rolled steel. However, the spring could alternatively utilize a bimetallic configuration so that the yieldable biasing force provided thereby is a variable spring rate that varies depending on temperature. Preferred materials for a bimetallic spring include the following metal alloys: nickel-titanium, copper-zinc-aluminum, or copper-aluminum-nickel.

As shown in FIGS. 6 and 7, the spring **60** is configured to couple to the stepped frustoconical lug section **56b** and extend therefrom to maintain pressure against the surface of the valve body **58** along its entire path of movement. In this regard, the steps of the lug section **56b** include an upper step configured to cooperate with the spring **60** to secure (i.e., frictionally engage) the spring **60** to the lug section **56b**, and a lower step configured to allow the spring **60** to be fully received on the lug section **56b** but not secured thereto (e.g., when the valve **16** is in the fully open position as shown in FIG. 7). The ribs **56c** of the lug **56** cooperate with the upper step to maintain the spring **60** in place on the stepped portion of the inner lug **56b**.

The valve **16** is normally in the closed position as shown in FIG. 6 and fluid flows from the filter inlet **30** through the filter media **14** out the filter outlet **46** and into the pump inlet of the pump P. When the suction force provided by the pump P creates a sufficient differential pressure across the valve **16** (e.g., at temperatures of -40 degrees Celsius and below the fluid is too viscous to be drawn through the media **14**), the biasing force of the spring **60** is overcome and the valve **16** opens. With the valve **16** open, fluid flows from the bypass inlet **32** (without passing through the media **14**) out the filter outlet **46** and into the pump inlet of the pump P (see FIG. 7). When the differential pressure across the valve **16** is sufficiently reduced (e.g., at temperatures of -18 degrees Celsius and above where the viscosity of the fluid is such that the fluid is adequately drawn through the media **14**), the biasing force of the spring **60** overcomes the suction force of the pump P and the valve **16** closes. The linear flow of fluid from the bypass inlet **32** to the filter outlet **46** combined with the qualities of the spring **60** optimize the opening and closing of the valve **16** in the desired conditions.

Because fluid flowing from the bypass inlet **32** to the filter outlet **46** does not pass through the filter media **14**, the bypass valve assembly preferably includes a bypass inlet filter **66** for filtering debris out of the fluid flowing from the bypass inlet **32** to the filter outlet **46** (see FIGS. 2 and 7). The bypass filter **66** is formed of any suitable material (e.g., metal screen) and configured to be engagingly received within the bypass inlet **32** so that fluid flowing through the inlet **32** passes through the filter **66**. The illustrated bypass filter **66** is in the form of a screen secured in place by crimping the collar **34a** of the projecting valve seat **34** over the circumferential edge of the filter **66** (see FIGS. 6 and 7).

The bypass valve assembly could utilize various alternative designs, constructions and materials. For example, the valve body could utilize a single positioning element cooperating with either the lug or the seat to restrict movement

in the second direction along the entire length of the path of movement. The assembly could utilize a biasing mechanism other than a spring. It is important; however, that the assembly provide the desired bypass capabilities (e.g., open in cold and/or start-up conditions and closed during normal operating conditions).

To initially assemble the illustrated filter **10**, the filter media **14** (unfolded) is placed in the tray section **18** so that the aperture **14a** aligns with filter inlet collar **30a** and the collar **30a** is crimped over the media **14** (see FIG. 1). The filter media **14** is folded in half so that the media **14** fills the baffled filter chamber and the fold-line aligns with the demarcation between the baffled portion and the non-baffled portion of the filter housing **12** (see FIGS. 1 and 2). The bypass inlet filter **66** is placed in the bypass inlet **32** under the collar **34a** and the collar **34a** is crimped over the open circumferential edge of the filter **66**. The valve body **58** is placed over the projecting valve seat **34** so that the seat lugs **62a** circumscribe the circumferential surface of the seat **34** (see FIG. 6). The spring **60** is coupled onto the inner lug section **56b** of the lug **56** on the hood section **20**. The hood section **20** is then placed into the tray section **18** so that distal and side edges of the filter media **14** are interposed between the lipped portion **24a** of the side wall **24** and the ribbed portion **38a** of the side wall **38** (see FIG. 1). The flanged portion **24b** of the side wall **24** is then crimped over the rib **38a** to secure the filter housing **12** together (see FIG. 5). The filter **10** is then placed into the transmission sump S and the neck **46a** is coupled to the pump inlet of the transmission pump P (see FIG. 1).

#### Operation

During initial start-up (e.g., the vehicle's engine is not currently running), when the transmission pump P is first activated, fluid stored above the primer valve **52** (this fluid was deposited in the valve **52** when the pump P was previously deactivated and the valve **52** closed—as shown in solid lines in FIG. 1—capturing fluid that would otherwise drain from the pump P back into the filter **10**) primes the pump P. Once the pump P is activated and primed, the primer valve **52** opens (as shown in phantom lines in FIG. 1) so that fluid flowing from the filter **10** can pass through the fluid inlets **50b** and into the pump inlet of the pump P.

Once the transmission pump P is activated, the suction force provided thereby draws fluid from the transmission sump S into the filter **10**, through the filter **10** where debris is filtered out of the fluid, and out of the filter **10** through the filter outlet **46** into the pump inlet of the pump P. Fluid is drawn into the filter **10** either through the filter inlet **30** or the bypass inlet **32** depending on the conditions. Under normal conditions (e.g., ambient temperatures of -18 degrees Celsius or above) the viscosity of the fluid is such that the fluid is adequately pulled into the filter inlet **30** and through the filter media **14** so that the differential pressure across the bypass valve assembly **16** does not overcome the biasing force exerted on the valve body **58** by the spring **60** and the valve **16** remains in the closed position as shown in FIG. 6. When the valve **16** is closed, the spring **60** retains the body **58** in sealing engagement with the projecting valve seat **34** and fluid is thereby prevented from flowing through the bypass inlet **32**. Fluid drawn through the filter media **14** enters the bag at the aperture **14a** and is pulled through the media **14** into the fluid channels defined by the baffles **28,40** where it is carried to the filter outlet **46** (see FIGS. 1 and 5). The media **14** is prevented from being sucked into the filter outlet **46** by the pinch point provided by the cooperation of



the projection **44** and the center tray baffle **28**. The media **14** is prevented from being sucked into the fluid channels by the projection **42** (see FIG. 1).

Under bypass conditions (e.g., ambient temperatures of  $-40$  degrees Celsius or below) the viscosity of the fluid is such that the fluid is not sufficiently pulled through the media **14** so that the differential pressure across the valve **16** overcomes the biasing force of the spring **60** to fully open the valve **16** as shown in FIG. 7. The suction force provided by the pump P, the axial alignment of the bypass inlet **32** and the filter outlet **46**, and the qualities of the spring **60** cooperate to determine what bypass conditions cause the valve to open and close. It is desirable to bypass the filter media in cold and/or start-up conditions where fluid is not sufficiently provided to the pump P. In the illustrated filter **10**, bypass occurs at approximately  $-40$  degrees Celsius and below and continues until the ambient temperature in and around the fluid is about  $-18$  degrees Celsius or above. When the valve **16** is fully open, the valve body **58** is held against the lug **56** so that fluid flows into the bypass inlet **32**, through the bypass filter inlet **66** where debris is filtered out of the fluid, and out of the filter outlet **46** into the pump inlet of the pump P (see FIG. 7). The valve **16** remains open until bypass conditions are no longer present (e.g., ambient fluid temperature has reached  $-18$  degrees Celsius) wherein the biasing force of the spring **60** overcomes the suction force of the pump P and closes the valve **16** by shifting the valve body **58** back into sealing engagement with the valve seat **34** (see FIG. 6).

When the valve **16** is shifting into and out of the closed position, the valve body **58** moves in the first direction along the defined path and thereby remains in continual alignment with both the valve seat **34** and the lug **56**. The valve body **58** is restricted from moving in the second direction (i.e., the direction of misalignment) by the cooperation of the first and second positioning elements **62,64** and the respective valve seat **34** and lug **56**. In particular, when the valve **16** is in the closed position the seat tabs **62a** circumscribably engage the circumferential surface of the seat **34** and continue this engagement as the valve body **58** shifts out of the closed position until the body **58** has moved sufficiently toward the fully open position that the lug tabs **64a** circumscribably engage the outer circumferential surface of the sheath section **56a** of the lug **56**. The lug tabs **64a** continue this engagement while the body **58** shifts into—and while the body **58** is in—the fully open position. This sequence is reversed as the body **58** shifts from the fully open position back into the closed position. In this manner, the body **58** is restricted from moving in the second direction along its entire path of movement.

It is noted that the bypass valve is configured to remain closed during normal operating conditions, which have been described herein as ambient temperatures of  $-18$  degrees Celsius or above. However, those skilled in the art will appreciate that conditions other than operating temperature may cause opening of the bypass valve **16** (e.g., clogging of the filter inlet **30**).

The preferred form of the invention described above is to be used as illustration only, and should not be utilized in a limiting sense in interpreting the scope of the present invention. Obvious modifications to the exemplary embodiment, as hereinabove set forth, could be readily made by those skilled in the art without departing from the spirit of the present invention.

The inventors hereby state their intent to rely on the Doctrine of Equivalents to determine and assess the reasonably fair scope of the present invention as pertains to any

apparatus not materially departing from but outside the literal scope of the invention as set forth in the following claims.

What is claimed is:

1. A transmission fluid filter comprising:
  - a filter housing having a proximal end and a distal end, the filter housing comprising:
    - a filter inlet, the filter inlet being disposed toward the distal end;
    - a bypass inlet spaced from the filter inlet, the bypass inlet being disposed toward the proximal end; and
    - an outlet spaced from the inlets, the outlet being disposed toward the proximal end;
  - filter media in the housing such that fluid flowing from the filter inlet to the outlet passes through the media and fluid flows from the bypass inlet to the outlet without passing through the media; and
  - a bypass valve associated with the bypass inlet, wherein there is disposed a valve body including a positioning element placed over a valve seat disposed on the filter housing wherein, said positioning element comprises a plurality of circumferentially spaced seat tabs for aligning the valve body with the valve seat, said bypass valve being shiftable into and out of a closed position in which fluid flow through the bypass inlet is prevented, said bypass inlet being defined about a bypass inlet axis and the outlet being defined about an outlet axis, said bypass inlet axis and said outlet axis being at least substantially parallel and at least in close proximity to one another.
2. The filter as claimed in claim 1, said filter housing including a top wall, a bottom wall spaced from the top wall, and at least one projection extending therebetween operable to substantially maintain the spacing.
3. The filter as claimed in claim 2, said at least one projection being configured so that a portion of the filter media is pinched between the projection and one of said walls so that the filter media is maintained such that fluid flowing from the filter inlet to the outlet passes through the media and fluid flows from the bypass inlet to the outlet without passing through the media.
4. The filter as claimed in claim 2, said bypass inlet axis and outlet axis being generally perpendicular to the top and bottom walls.
5. The filter as claimed in claim 1, said bypass valve being yieldably biased into the closed position.
6. A transmission fluid filter comprising:
  - a filter housing having a proximal end and a distal end, the filter housing comprising:
    - a filter inlet, the filter inlet being disposed toward the distal end;
    - a bypass inlet spaced from the filter inlet, the bypass inlet being disposed toward the proximal end; and
    - an outlet spaced from the inlets, the outlet being disposed toward the proximal end;
  - a filter media in the filter housing such that fluid flowing from the filter inlet to the outlet passes through the filter media and fluid flows from the bypass inlet to the outlet without passing through the media; and
  - a bypass valve assembly shiftable into and out of a closed position in which fluid flow through the bypass inlet is prevented, said bypass valve assembly including a projecting valve seat and a valve body disposed over the projecting valve seat, shiftable in a first direction into and out of sealing engagement with the projecting valve seat, said



## 11

valve body including a positioning element extending toward the projecting valve seat wherein, said positioning element comprises a plurality of circumferentially spaced seat tabs extending toward the projecting valve seat and cooperating therewith to restrict movement of the valve body in a second direction, wherein the first and the second directions are at least generally unparallel to one another.

7. The filter as claimed in claim 6, said bypass valve assembly including a lug in an opposed relationship with the valve seat, said valve body including a second positioning element projecting oppositely relative to the first positioning element, said second positioning element extending toward the lug and cooperating therewith to restrict movement of the valve body in the second direction.

8. The filter as claimed in claim 7, said positioning elements being configured so that the elements cooperate to maintain a circumscribing relationship with either the lug or the seat so that movement of the valve body in the second direction is constantly restricted.

9. The filter as claimed in claim 7, said valve assembly including a spring associated with the lug and operable to yieldably bias the valve assembly into the closed position.

10. The filter as claimed in claim 9, said lug having at least a portion thereof having a generally frustoconical shape and being operable to receive the spring.

11. The filter as claimed in claim 10, said at least a portion of the lug having a stepped configuration wherein at least one step is operable to couple the spring to the lug and at least one additional step is operable to receive the spring without coupling the spring to the lug.

12. The filter as claimed in claim 6, said valve assembly being yieldably biased toward the closed position.

13. The filter as claimed in claim 6, said bypass valve assembly including a bypass inlet filter operable to filter debris out of fluid flowing from the bypass inlet to the outlet.

14. A transmission fluid filter comprising:

a filter housing having a proximal end and a distal end, the filter housing comprising:

a filter inlet, the filter inlet being disposed toward the distal end;

a bypass inlet spaced from the filter inlet, the bypass inlet being disposed toward the proximal end; and an outlet spaced from the inlets, the outlet being disposed toward the proximal end;

filter media in the housing such that fluid flowing from the filter inlet to the outlet passes through the media and fluid flows from the bypass inlet to the outlet without passing through the media; and

a bypass valve assembly shiftable into and out of a closed position in which fluid flow through the bypass inlet is prevented,

said bypass valve assembly including a projecting valve seat, a valve body disposed over the projecting valve seat shiftable in a first direction into and out of sealing engagement with the projecting valve seat, and a lug operable to limit the range of movement of the valve body in the first direction to a path, wherein said valve body comprises a positioning element having a plurality of circumferentially spaced seat tabs configured to cooperate with the lug and the projecting valve seat to restrict, along the entire path, movement of the valve body in a second direction,

said first and the second directions being at least generally unparallel to one another.

## 12

15. A transmission fluid filter comprising:

a filter housing having a proximal end and a distal end, the filter housing comprising:

a filter inlet, the filter inlet being disposed toward the distal end;

a bypass inlet spaced from the filter inlet, the bypass inlet being disposed toward the proximal end; and an outlet spaced from the inlets, the outlet being disposed toward the proximal end wherein the outlet and the bypass inlet allow for fluid flow from the bypass inlet to the outlet to travel in a substantially linear path;

filter media in the housing such that fluid flowing from the filter inlet to the outlet passes through the media and fluid flows from the bypass inlet to the outlet without passing through the media; and

a bypass valve assembly shiftable into and out of a closed position in which fluid flow through the bypass inlet is prevented, wherein the bypass valve assembly comprises a valve body having a positioning element wherein said positioning element comprises a plurality of circumferentially spaced seat tabs, wherein the seat tabs align the valve body with the valve seat,

said bypass valve assembly including a biasing mechanism yieldably biasing the assembly into the closed position, and

said mechanism being configured so that the yieldable biasing force provided thereby varies depending on temperature.

16. The filter as claimed in claim 15, said biasing mechanism comprising a bimetallic spring.

17. The filter as claimed in claim 16, said first positioning element extending toward the valve seat and cooperating therewith to restrict movement of the valve body in a second direction, wherein the first and second directions are at least generally unparallel to one another.

18. The filter as claimed in claim 17, said bypass valve assembly including a lug in an opposed relationship with the valve seat, said valve body including a second positioning element projecting oppositely relative to the first positioning element, said second positioning element extending toward the lug and cooperating therewith to restrict movement of the valve body in the second direction.

19. The filter as claimed in claim 18, said positioning elements configured so that the elements cooperate to maintain a circumscribing relationship with either the lug or the seat so that movement of the valve body in the second direction is constantly restricted.

20. The filter as claimed in claim 19, said lug having at least a portion thereof having a generally frustoconical shape and being operable to receive the spring.

21. The filter as claimed in claim 20, said at least a portion of the lug having a stepped configuration wherein at least one step is operable to couple the spring to the lug and at least one additional step is operable to receive the spring without coupling the spring to the lug.

22. The filter as claimed in claim 21, said bypass valve assembly including a bypass inlet filter operable to filter debris out of fluid flowing from the bypass inlet to the outlet.

23. In a powered vehicle including a lubricated transmission having a transmission sump and a transmission pump, a fluid filter fluidly interposed between the sump and the pump, the filter comprising:

a filter housing having a proximal end and a distal end, the filter housing comprising:

a filter inlet, the filter inlet being disposed toward the distal end;



## 13

a bypass inlet spaced from the filter inlet, the bypass inlet being disposed toward the proximal end; and an outlet spaced from the inlets, the outlet being disposed toward the proximal end;

filter media in the housing such that fluid flowing from the filter inlet to the outlet passes through the media and fluid flows from the bypass inlet to the outlet without passing through the media; and

a bypass valve associated with the bypass inlet, said bypass valve being shiftable into and out of a closed position in which fluid flow through the bypass inlet is prevented, said bypass valve comprises a positioning element having a plurality of circumferentially spaced seat tabs,

said bypass valve disposed over a projecting valve seat, wherein the seat tabs align the valve body with the valve seat,

said bypass inlet being defined about a bypass inlet axis and said outlet being defined about an outlet axis, and said axis being at least substantially parallel and at least in close proximity to one another.

**24.** In a powered vehicle as claimed in claim **23**, said filter housing including a top wall, a bottom wall spaced from the top wall, and at least one projection extending therebetween operable to substantially maintain the spacing.

**25.** In a powered vehicle as claimed in claim **24**, said at least one projection being configured so that a portion of the filter media is pinched between the projection and one of said walls so that the filter media is maintained such that fluid flowing from the filter inlet to the outlet passes through the media and fluid flows from the bypass inlet to the outlet without passing through the media.

**26.** In a powered vehicle including a lubricated transmission having a transmission sump and a transmission pump, a fluid filter fluidly interposed between the sump and the pump, the filter comprising:

a filter housing having a proximal end and a distal end, the filter housing comprising:

a filter inlet, the filter inlet being disposed toward the distal end;

a bypass inlet spaced from the filter inlet, the bypass inlet being disposed toward the proximal end; and an outlet spaced from the inlets, the outlet being disposed toward the proximal end;

filter media in the housing such that fluid flowing from the filter inlet to the outlet passes through the media and fluid flows from the bypass inlet to the outlet without passing through the media; and

a bypass valve assembly shiftable into and out of a closed position in which fluid flow through the bypass inlet is prevented, said bypass valve assembly including a projecting valve seat and a valve body shiftable in a first direction into and out of sealing engagement with the projecting valve seat,

said valve body including a positioning element extending toward the projecting valve seat and cooperating therewith to restrict movement of the valve body in a second direction, wherein the first and the second directions are at least generally unparallel to one another; and

said positioning element comprises a plurality of circumferentially spaced seat tabs for restricting movement of the valve body in the second direction.

**27.** In a powered vehicle including a lubricated transmission having a transmission sump and a transmission pump, a fluid filter fluidly interposed between the sump and the pump, the filter comprising:

## 14

a filter housing having a proximal end and a distal end, the filter housing comprising:

a filter inlet, the filter inlet being disposed toward the distal end;

a bypass inlet spaced from the filter inlet, the bypass inlet being disposed toward the proximal end; and an outlet spaced from the inlets, the outlet being disposed toward the proximal end;

filter media in the housing such that fluid flowing from the filter inlet to the outlet passes through the media and fluid flows from the bypass inlet to the outlet without passing through the media; and

a bypass valve assembly shiftable into and out of a closed position in which fluid flow through the bypass inlet is prevented, said bypass valve assembly including a projecting valve seat, a valve body shiftable in a first direction into and out of sealing engagement with the projecting valve seat, and a lug operable to limit the range of movement of the body in the first direction to a path,

said valve body being configured to cooperate with the lug and valve seat to restrict, along the entire path, movement of the valve body in a second direction, said first and second directions being at least generally unparallel to one another; and

said valve body comprising a positioning element extending toward the projecting valve seat wherein, said positioning element comprises a plurality of circumferentially spaced seat tabs for restricting movement of the valve body in the second direction.

**28.** In a powered vehicle as claimed in claim **27**, said bypass valve assembly including a bypass inlet filter operable to filter debris out of fluid flowing from the bypass inlet to the outlet.

**29.** In a powered vehicle including a lubricated transmission having a transmission sump and a transmission pump, a fluid filter fluidly interposed between the sump and the pump, the filter comprising:

a filter housing having a proximal end and a distal end, the filter housing comprising:

a filter inlet, the filter inlet being disposed toward the distal end;

a bypass inlet spaced from the filter inlet, the bypass inlet being disposed toward the proximal end; and an outlet spaced from the inlets, the outlet being disposed toward the proximal end wherein the outlet and the bypass inlet allow for fluid flow from the bypass inlet to the outlet to travel in a substantially linear path;

filter media in the housing such that fluid flowing from the filter inlet to the outlet passes through the media and fluid flows from the bypass inlet to the outlet without passing through the media; and a bypass valve assembly shiftable into and out of a closed position in which fluid flow through the bypass inlet is prevented,

said bypass valve assembly including a biasing mechanism yieldably biasing the assembly into the closed position, said mechanism being configured so that the yieldable biasing force provided thereby varies depending on temperature;

said bypass valve assembly comprising a valve body disposed over a projecting valve seat, wherein the valve body comprises a positioning element extending toward the projecting valve seat wherein, said positioning element comprises a plurality of circumferentially spaced seat tabs for aligning the valve body with the valve seat.



15

**30.** In a powered vehicle as claimed in claim **29**, said biasing mechanism being a bimetallic spring.

**31.** In a powered vehicle as claimed in claim **30**, said bypass valve assembly further including a lug having at least a portion thereof having a generally frustoconical shape and being operable to receive the spring.

**32.** In a powered vehicle as claimed in claim **31**, said at least a portion of the lug having a stepped configuration wherein at least one step is operable to couple the spring to the lug and at least one additional step is operable to receive the spring without coupling the spring to the lug.

**33.** A transmission filter for filtering a fluid from a sump to a transmission pump inlet, the transmission filter comprising:

a filter housing having a proximal end relative to the transmission pump inlet and a distal end relative to the transmission pump inlet;

filter media having a length and attached to the filter housing;

a filter inlet being disposed toward the distal end;

a filter outlet defined about an outlet axis and disposed generally at the proximal end; and

a filter bypass valve assembly disposed at the proximal end, the filter bypass valve assembly comprising a bypass inlet and a bypass valve, the bypass inlet being defined about a filter bypass inlet axis and the bypass valve being shiftable into and out of a closed position in which fluid flow through the bypass inlet is prevented, wherein said outlet axis and the filter bypass inlet axis being at least substantially parallel and at least in close proximity to one another,

wherein the filter inlet is positioned in the transmission filter such that fluid flowing through the filter inlet to the outlet passes through the filter media, the filter bypass inlet is positioned such that fluid flows directly into the filter bypass inlet without first flowing through the filter inlet and such that fluid flowing through the bypass inlet is directed to the outlet without passing through the filter media, and wherein the bypass inlet axis and the outlet axis are positioned in relation to one another such that fluid flowing from the bypass inlet to the filter outlet flows along a path that is more direct relative to fluid flowing from the filter inlet to the filter outlet,

wherein the bypass valve is disposed over a projecting valve seat and the bypass valve comprises a positioning element having a plurality of circumferentially spaced seat tabs for aligning the valve body with the valve seat.

**34.** A transmission filter according to claim **33**, wherein the filter housing comprises a tray section and a hood section cooperatively defining a filter chamber therebetween, the

16

filter media is disposed within the filter housing, and the bypass valve assembly is spaced from the media.

**35.** A transmission filter according to claim **34**, wherein the tray portion includes a bottom wall, a side wall, and at least one baffle formed in the bottom wall and extending into the filter chamber.

**36.** A transmission filter according to claim **35**, wherein the at least one baffle does not extend the entire length of the bottom wall.

**37.** A transmission filter according to claim **36**, wherein the at least one baffle spans a length of the bottom wall proportionate to the length of the filter media.

**38.** A transmission filter according to claim **37**, wherein the bypass inlet is formed in the tray section toward the proximal end of the transmission filter in a region in which the at least one baffle does not extend and the filter inlet is spaced apart from the bypass inlet toward the distal end of the transmission filter in a region in which the at least one baffle does extend.

**39.** A transmission filter according to claim **34**, wherein the hood section has a top wall, a side wall, and at least one baffle and at least one baffle formed in the top wall and extending into the filter chamber.

**40.** A transmission filter according to claim **39**, wherein the at least one baffle does not extend the entire length of the top wall such that the hood section has a baffled portion and a non-baffled portion.

**41.** A transmission filter according to claim **40**, wherein the at least one baffle spans a length of the top wall proportionate to the length of the filter media.

**42.** A transmission filter according to claim **41**, wherein the transmission filter further comprises a distal and a proximal frustoconical projection formed in the top wall of the hood section.

**43.** A transmission filter according to claim **42**, wherein the distal frustoconical projection is generally located near the geometric center of the top wall and the proximal frustoconical projection is generally located at or near a demarcation between the baffled portion and the non-baffled portion of the hood section.

**44.** A transmission filter according to claim **42**, wherein the proximal frustoconical projection cooperates with the tray section to form a pinch-point for the filter media.

**45.** A transmission filter according to claim **40**, wherein the filter outlet is formed in the non-baffled portion of the hood section.

**46.** A transmission filter according to claim **34**, wherein the filter media cooperates with the filter housing to form a filter bag around the filter inlet.

\* \* \* \* \*