



US006957976B2

(12) **United States Patent**  
**Zhang**

(10) **Patent No.:** **US 6,957,976 B2**  
(45) **Date of Patent:** **Oct. 25, 2005**

(54) **I/O CONNECTOR WITH LOCK-RELEASE MECHANISM**

(75) Inventor: **Hongbo Zhang**, Kunsan (CN)

(73) Assignee: **Hon Hai Precision Ind. Co., LTD**,  
Taipei Hsien (TW)

(\*) Notice: Subject to any disclaimer, the term of this patent is extended or adjusted under 35 U.S.C. 154(b) by 0 days.

(21) Appl. No.: **10/951,484**

(22) Filed: **Sep. 27, 2004**

(65) **Prior Publication Data**

US 2005/0070148 A1 Mar. 31, 2005

(30) **Foreign Application Priority Data**

Sep. 26, 2003 (TW) ..... 92217370 U

(51) **Int. Cl.**<sup>7</sup> ..... **H10R 13/627**

(52) **U.S. Cl.** ..... **439/358**

(58) **Field of Search** ..... 439/358, 327,  
439/353, 357, 350, 540.1

(56) **References Cited**

**U.S. PATENT DOCUMENTS**

5,975,957 A 11/1999 Noda et al.  
6,099,339 A 8/2000 Yanagida et al.  
6,132,231 A 10/2000 Suzuki  
6,152,754 A \* 11/2000 Gerhardt et al. .... 439/325  
6,165,006 A \* 12/2000 Yeh et al. .... 439/490

6,254,417 B1 7/2001 Pan  
6,454,589 B1 \* 9/2002 Yeh ..... 439/352  
6,457,987 B1 \* 10/2002 Yeh ..... 439/352  
6,558,183 B1 \* 5/2003 Ji et al. .... 439/358  
6,705,899 B1 \* 3/2004 Ji ..... 439/660  
6,863,546 B2 \* 3/2005 Yang et al. .... 439/79  
6,865,369 B2 \* 3/2005 Semmeling et al. .... 434/357  
2004/0137779 A1 \* 7/2004 Wei ..... 439/358  
2005/0026492 A1 \* 2/2005 Zhang et al. .... 439/358  
2005/0048830 A1 \* 3/2005 Li et al. .... 439/358  
2005/0064758 A1 \* 3/2005 Li et al. .... 439/358

\* cited by examiner

*Primary Examiner*—Gary Paumen

*Assistant Examiner*—Phuongchi Nguyen

(74) *Attorney, Agent, or Firm*—Wei Te Chung

(57) **ABSTRACT**

A connector (100) includes a cover defining a receiving space for receiving a terminal module (3). A notch (15) is defined through a side wall of the cover. A concaved stop portion (151) is defined in the side wall of the cover and communicating with the notch. The terminal module has a number of terminals (33) held therein and includes a forwardly projecting mating portion (32) beyond the cover. A lock member (34) is received in the housing for mating with a mating connector. A lock-release button (24) is received in the notch for urging the lock member into a release position and includes a fixing end fixed to the cover and a free operating base (240) swinging about the fixing end. A stop plate (241) projects from the free operating base to engage with the stop portion of the cover for preventing the lock-release button disengaging the notch.

**3 Claims, 5 Drawing Sheets**

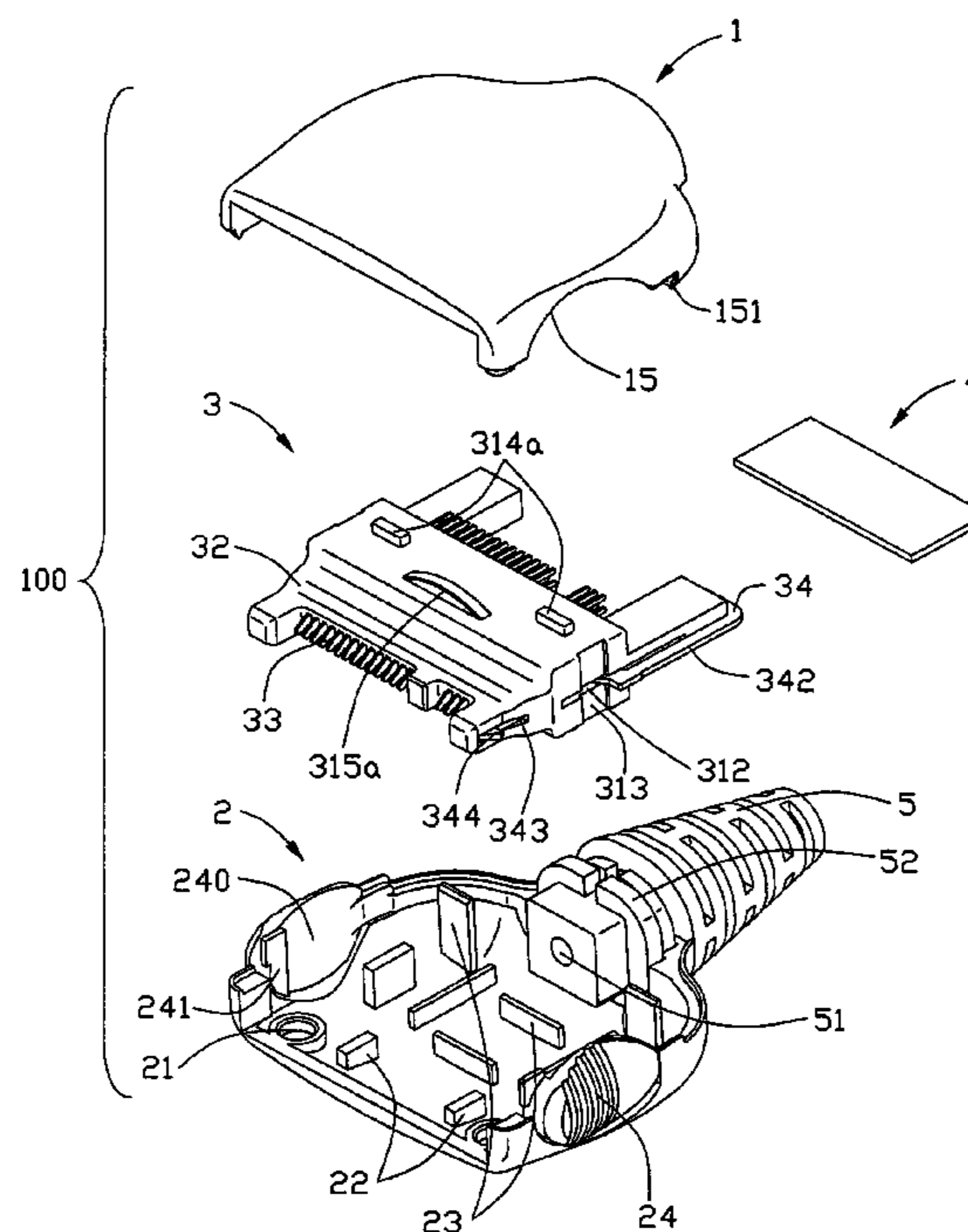

100  
~

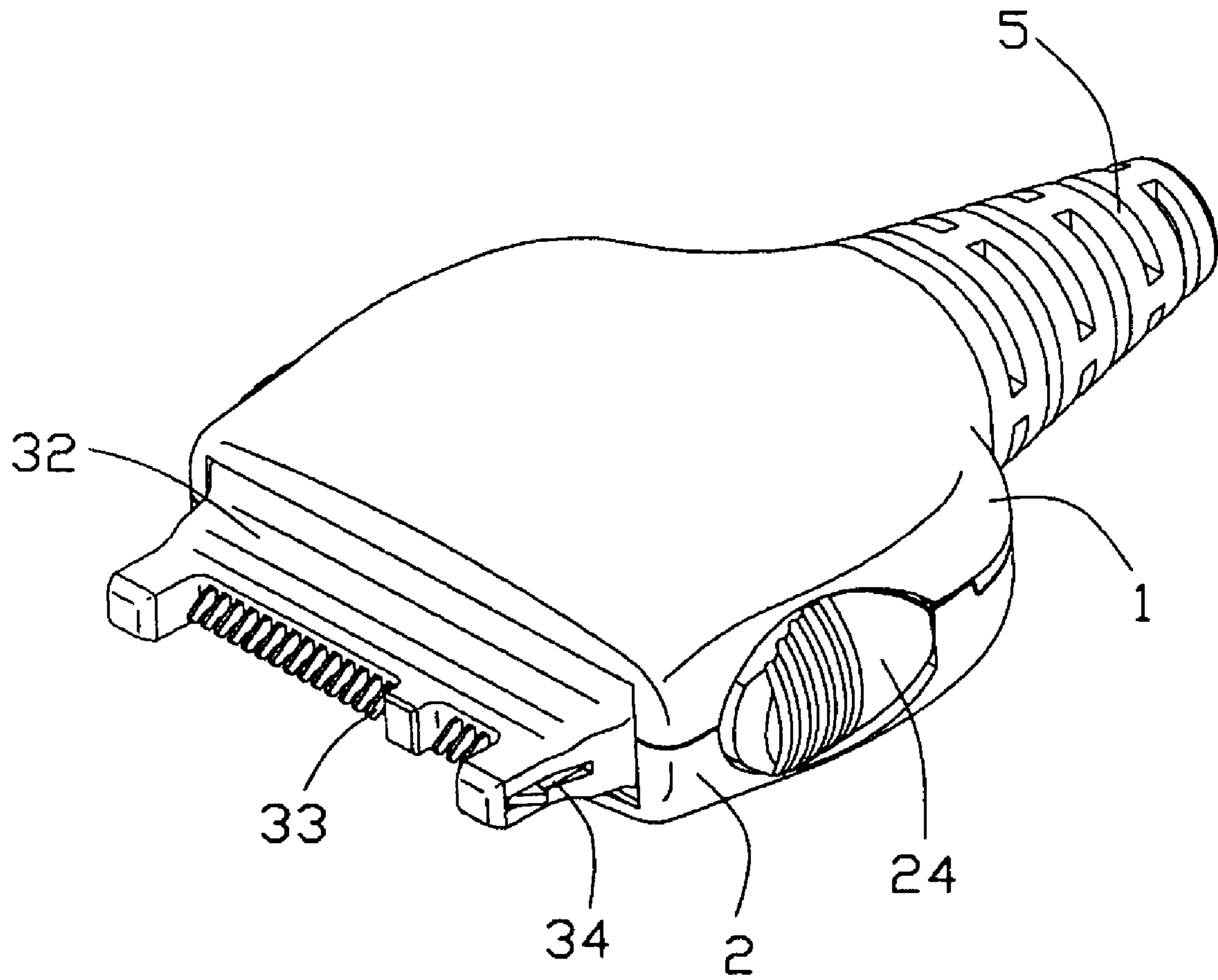

FIG. 1

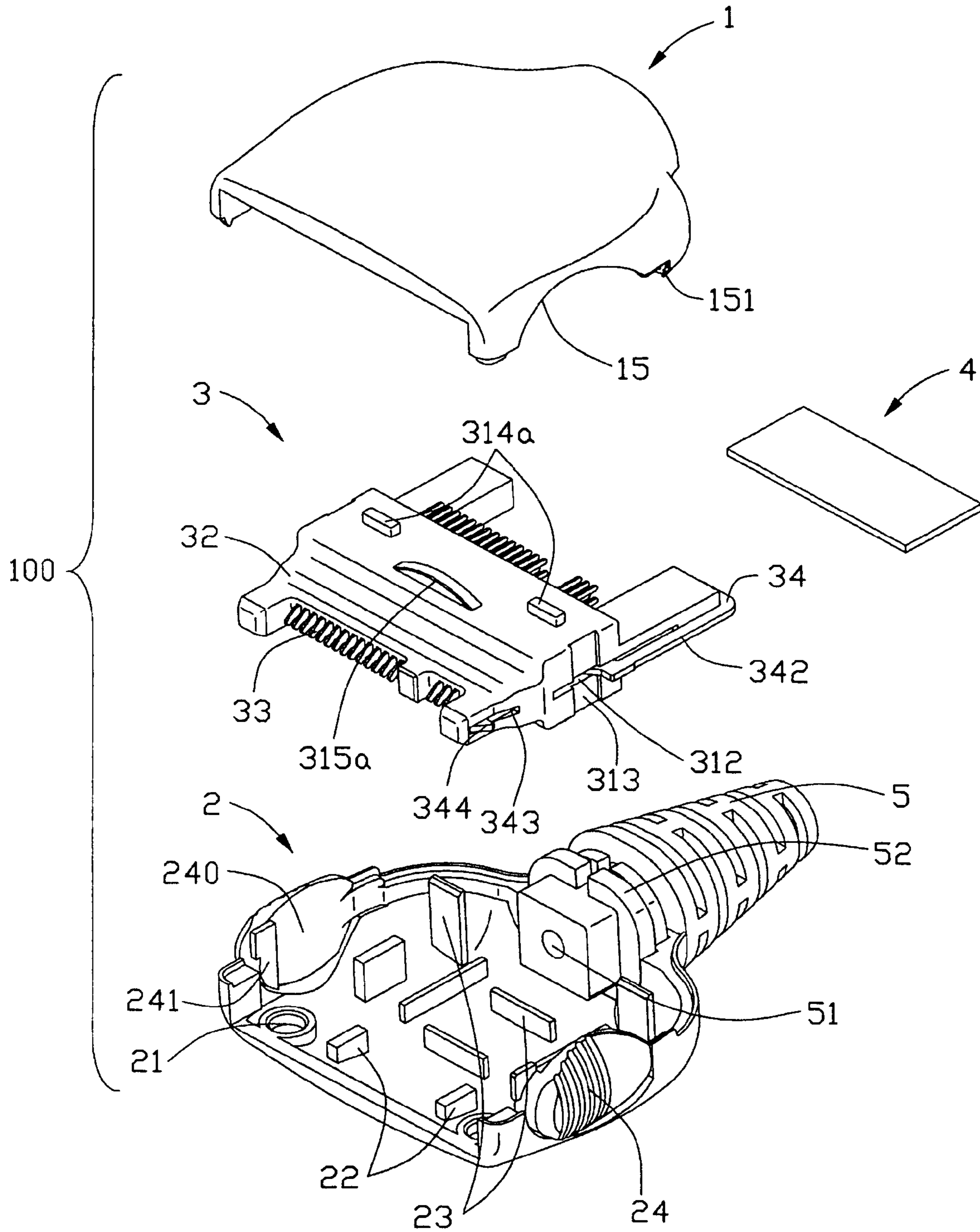

FIG. 2



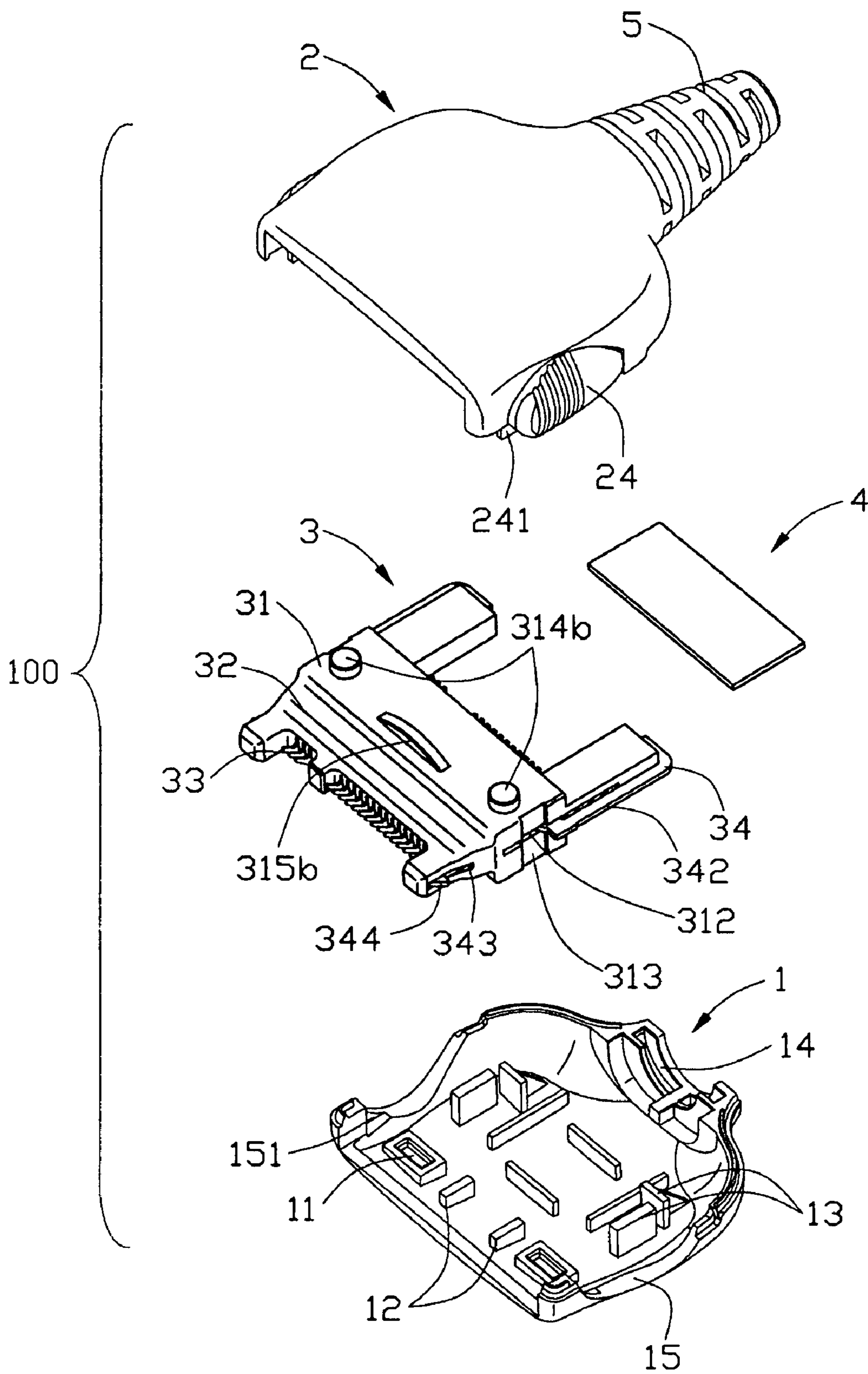

FIG. 3

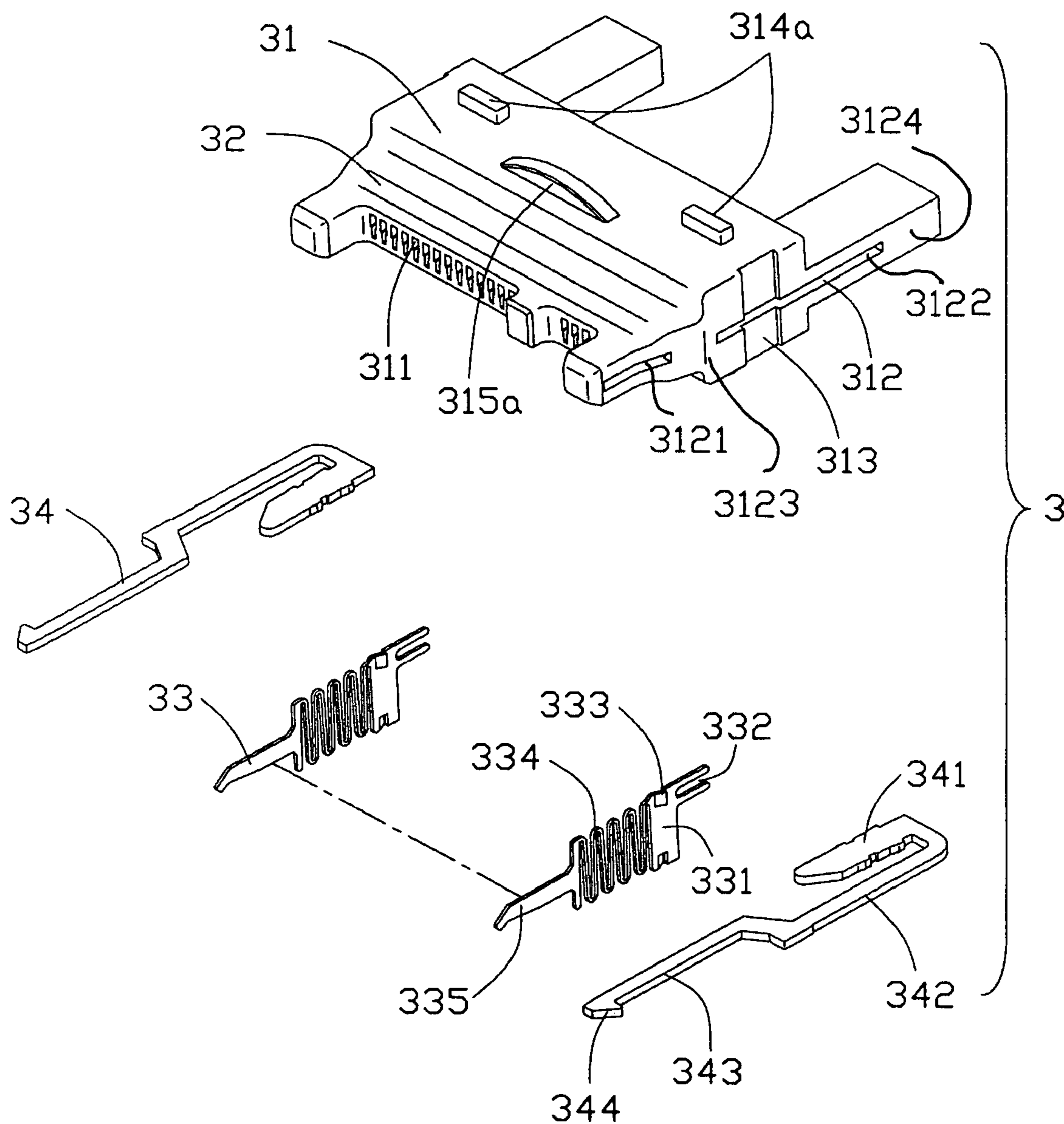

FIG. 4

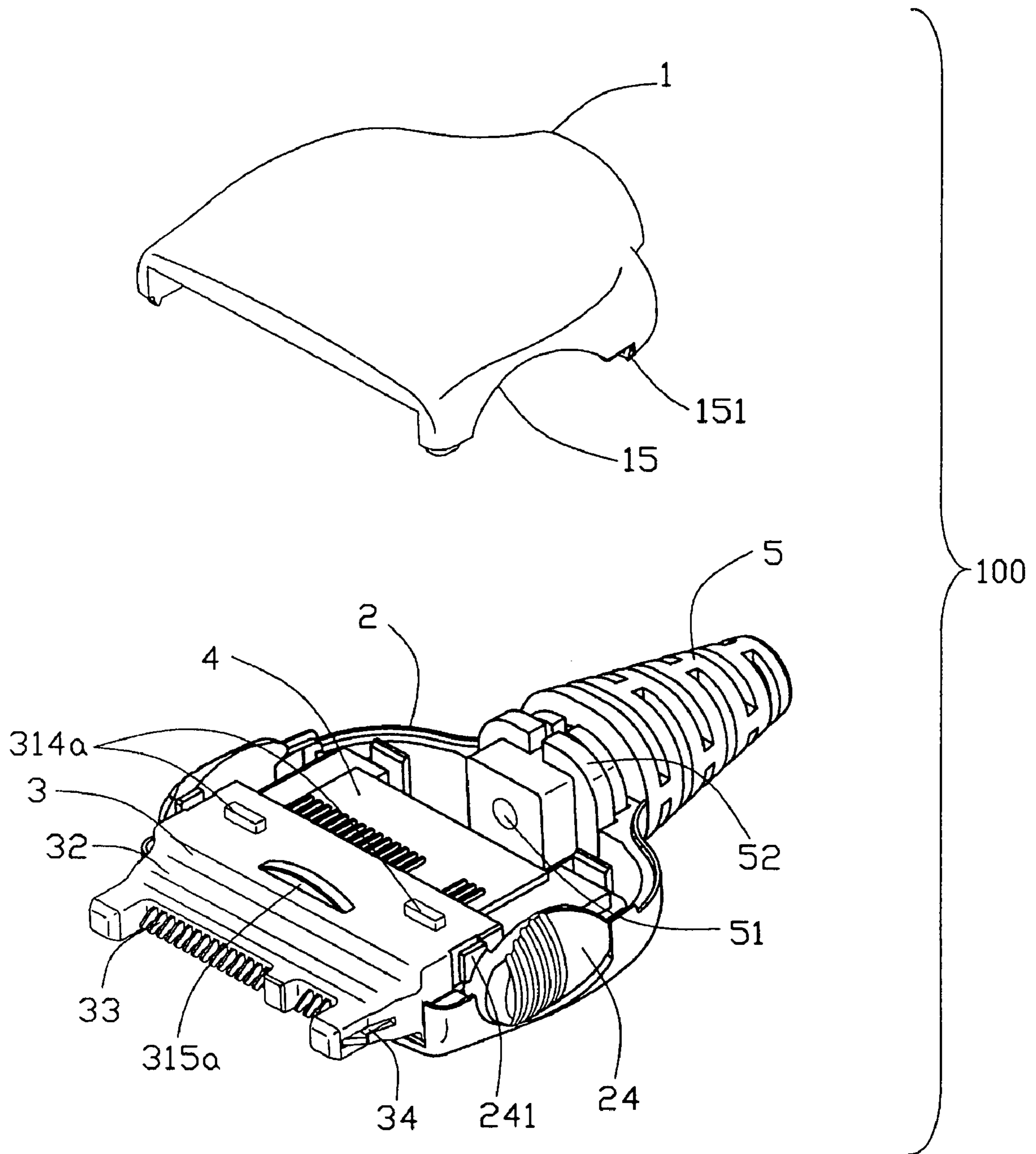

FIG. 5



1

## I/O CONNECTOR WITH LOCK-RELEASE MECHANISM

### BACKGROUND OF THE INVENTION

#### 1. Field of the Invention

The present invention generally relates to an input/output (I/O) connector, and more particularly, to an I/O connector having an improved lock-release mechanism.

#### 2. Description of the Prior Art

Portable communications devices, such as cellular telephones, pagers, personal data assistants (PDA) etc., have been widely used in everyday life in recent years. Such devices frequently need to be charged, or connected to another device, such as a personal computer (PC) to upload or download information. As is known, an input/output (I/O) connector is employed to establish electrical connection between electronic devices. Such an I/O connector generally includes a housing body and a plurality of contacts extending outside the housing for mating with the electrical device. The housing has a pair of lock members in opposite side walls thereof and a pair of cantilevered release buttons corresponding to the lock members. Each lock member has a resilient arm and a hook portion projects upwardly on the free end of the resilient arm. A cam section is provided on the release button. A cam follower is provided on the resilient arm for exerting an inward squeezed force on the resilient arm. To connect the connector to the electrical device, the hook portions of the lock members are pressed inwardly and the contacts electrically connect with the electrical device. The resilient arms spring back so that the hook portions engage the engaging portions of the electrical device. To disengage the connector from the electrical device, the release buttons are squeezed toward the housing body, the cam sections press inwardly corresponding cam followers of the resilient arms. The hook portions of the resilient arms are released from the engagement with the mating connector.

However, such the I/O connector of prior art involves such problems as the release button is of a cantilevered configuration with a base locking with the housing body. The release button is inclined to project outwardly and cannot return to its normal position after a period of use. The outwardly projecting release buttons are easily damaged by unexpected external force. In addition, the engagement between the cam section of the release unite and the cam follower of the resilient arm is of a line-to-line fashion, likely to result an unreliable connection therebetween.

Hence, an improved I/O connector is required to overcome the disadvantages of the prior art.

### BRIEF SUMMARY OF THE INVENTION

A primary object of the present invention is to provide an I/O connector with improved lock-release buttons which are compact and are able to provide stable lock and release operation.

To fulfill the above-mentioned objects, according to a preferred embodiment of the present invention, an I/O connector includes a top cover and a bottom cover interlocked with the top cover defining a receiving space therebetween. The top cover defines a pair of notches at side walls thereof and each has a concaved stop portion communicating with the notch. A terminal module is received in the receiving space. The terminal module is adapted for receiving a plurality of terminals and includes a forwardly projecting mating portion beyond the cover. A pair of lock

2

members are received in the housing for mating with a mating connector. A pair of lock-release buttons are received in the notches for urging the lock members into a release position and each include a fixing end fixed to the bottom cover and a free operating base swinging about the fixing end. A stop plate projects from each free operating base to engage with the stop portion of the cover for preventing the lock-release button from disengaging the notch.

Other objects, advantages and novel features of the invention will become more apparent from the following detailed description when taken in conjunction with the accompanying drawings.

### BRIEF DESCRIPTION OF THE DRAWINGS

The foregoing summary, as well as the following detailed description of the embodiments of the present invention, will be better understood when read in conjunction with the appended drawings. For the purpose of illustrating the invention, there are shown in the drawings embodiments which are presently preferred. As should be understood, however, the invention is not limited to the precise arrangements and instrumentalities shown. In the drawings:

FIG. 1 is a perspective view of an I/O connector according to the present invention.

FIG. 2 is an exploded view of FIG. 1.

FIG. 3 is an exploded view similar to FIG. 2, but taken from another perspective.

FIG. 4 is an exploded view of a terminal module of the I/O connector.

FIG. 5 is an assembled view of FIG. 2, wherein an upper cover is upwardly lifted for clarity.

### DETAILED DESCRIPTION OF THE PREFERRED EMBODIMENT

Referring to the drawings in greater detail, and first to FIGS. 1-4, an input/output (I/O) connector **100** according to the present invention has a two-part construction including a top cover **1** and a bottom cover **2**. The top cover **1** interlocks with the bottom cover **2** thus defining a receiving space (not labeled) therebetween for receiving a terminal module **3**. An internal printed circuit board (PCB) **4** is assembled to the terminal module **3**. A strain relief **5** is assembled at rear ends of the assembled covers **1, 2**.

The top cover **1** defines a pair of downwardly projecting brackets **11** and forms a pair of downwardly projecting first embossments **12** at a front portion of an inner surface thereof. The first embossments **12** position between the brackets **11**. A plurality of first supporting frames **13** are downwardly formed at a middle inner surface of the top cover **1**. A pair of mounting slots **14** are defined at a rear end of the top cover **1**. A pair of notches **15** are symmetrically formed on opposite downwardly extending side walls of the top cover **1**. A concaved stop portion **151** is defined in an inner surface of each side wall and communicate with a front end of each notch **15**.

The bottom cover **2** defines a pair of low holes **21** and forms a pair of upwardly projecting second embossments **22** at a front portion of an inner surface thereof. The second embossments **22** position between the low holes **21**. A plurality of second supporting frames **23** are upwardly formed at middle inner surface of the bottom cover **2**. A pair of lock-release buttons **24** are provided respectively at opposite side walls of the bottom cover **2**. Each lock-release button **24** has a rear fixing end fixed with an inner surface of the bottom cover **2** and a front free operating base **240** swing



about the fixing end for being squeezed to take the I/O connector **100** into a released position. In this embodiment, the lock-release buttons **24** are integrally molded with the cover. The operating base **240** is substantially quarter-cartouche shaped. A plurality of raised serrated bosses (not labeled) is provided on outer surfaces of operating base **240** for engagement by an operator's thumb or finger. A stop plate **241** projects upwardly and forwardly from the operating base **240**. The stop plate **241** engages with the stop portion **151** of the top cover **1** for preventing an outward movement of the lock release button **24**.

The terminal module **3** is one-piece structure unitarily molded of dielectric material such as plastic or the like and includes a generally U-shaped dielectric housing body **31** and a forwardly projecting mating portion **32** for engaging with a mating portion of a mating connector. The housing body **31** defines a plurality of passageways **311** and forwardly extending through a middle of the mating portion **32** for receiving a plurality of terminals **33**. A pair of grooves **312** horizontally extend front-to-rear at opposite sides of the housing body **31** and the mating portion **32** for retaining and confining a pair of retractably lock members **34** wherein most portions of the groove **312** are outwardly exposed to the exterior in a lateral direction except portions blocked by the partition walls **3123**, **3124** so as to form only the portions **3121** and **3122** of the groove **312** are outwardly exposed to the exterior in the lateral direction. The housing body **31** has a pair of concaved cutouts **313** at each side for engaging with stop plates **241** of the lock-release buttons **24** when the lock-release buttons **24** are pressed. Corresponding to the brackets **11** and the first embossments **12** of the top cover **1**, a pair of bosses **314a** and a first rib **315a** are formed on a lower surface of the housing body **31**. Corresponding to the low holes **21** and the second embossments **22** of the bottom cover **2**, a pair of poles **314b** and a second rib **315b** are formed on an upper surface of the housing body **31**.

Referring to FIG. 4, the terminal **33** includes a base portion **331** and a solder portion **332** extending rearwardly from a rear end of the base portion **331**. A concave **333** is formed at the base portion **331** for securely engaging with the passageways **311** and the solder portion **332**. A contact portion **335** extends forwardly from a front end of the base portion **331** and connects to the base portion **331** via a spring portion **334** which can cushion the force from the contact portion **335** received from a mating connector.

The pair of lock members **34** are accommodated in the grooves **312** of the housing body **31**. Each lock members **34** comprises a retention portion **341**, a press portion **342** with the retention portion **341** forming a generally U-shaped structure, a resilient arm **343** extending from the press portion **342** and a hook portion **344** on a free end of the resilient arm **343** being exposed to an outside.

Referring to FIG. 2, the strain relief **5** has a hole **51** therethrough in a front-to-rear direction for receiving an end of a mating cable and a pair of mounting flanges **52** at front portion thereof. The mounting flanges **52** are provided for cooperating with the mounting slots **14** of the top cover **1**.

Referring to FIGS. 1-5, in assembly, the terminals **33** are received in the passageways **311** of the terminal module **3** with the solder portions **332** rearwardly extending out of the middle housing body **31** and the contact portions **335** forwardly extending out of the front edge of the mating portion **32**. The lock members **34** are horizontally installed into the grooves **312** of housing body **31**, with the press portions **342** and the hook portions **344** exposed out of the side walls of the housing body **31** wherein the resilient arm **343** with the hook portion **344** is first inwardly and laterally

inserted into the portion **3122**, and successively the whole lock member **34** is moved along a lengthwise direction of the groove **312** until the U-shaped retention portion **341** and pressing portion **341** engaged with the partition wall **3124**. The PCB **4** is soldered to the solder portions **332** of the terminals **33** and a free edge of the PCB **4** blocked in the terminal module **3**. The assembled terminal module **3** is mounted onto the bottom cover **2** (referring to FIG. 5) with the PCB **4** being supported by the second supporting frames **23**, and with the posts **314b** and the second rib **315b** of the terminal module **3** respectively engaging with the lower holes **21** and the second embossments **22** of the bottom cover **2**. The mating portion **32** extends beyond a front edge of the bottom cover **2** for mating with the mating connector.

The top cover **1** is interlocked with the bottom cover **2** thereafter. The bosses **314a** and the first rib **315a** of the terminal module **3** respectively engage with the brackets **11** and the first embossments **12** of the top cover **1**, thereby securing holding the terminal module **3** between the top cover **1** and the bottom cover **2**. The mounting slots **14** mount with the mounting flanges **52** of the strain relief **5**. The notches **15** of the top cover **1** retain the lock-release buttons **24** with the stop portions **151** engaging with corresponding stop plates **241**, thereby securing holding the lock-release buttons **24** between the top cover **1** and the bottom cover **2**.

When mating with the mating connector is desired, the lock-release buttons **24** of the I/O connector **100** are inwardly pressed. The operating bases **240** of the lock-release buttons **24** inwardly depress corresponding pressing portions **342** of the lock members **34**. The pressing portions **342** urge the resilient arms **343** and the hook portions **344** move inwardly, the stop plates **241** of the lock-release buttons **24** bias against corresponding cutouts **313** of the terminal module **3**, thereby rendering the lock members **34** received in the grooves **312** completely and allowing the mating occurs. When the mating completed, the lock-release buttons **24** are released. The press portions **342** and the resilient arms **343** move outwardly, whereby the hook portions **344** of the I/O connector **100** respectively engage with counterpart locking portions of the mating connector. A locking state between the I/O connector **100** and the mating connector is established.

Similarly, to disengage the I/O connector **100** from the mating connector, the lock-release buttons **24** are inwardly depressed, the pressing portions **342** of the lock members **34** inwardly deflect resilient arms **343** and the hook portions **344**, thereby disengaging the hook portions **344** from the counterpart lock portions of the mating connector and releasing the locking between the I/O connector **100** and the mating connector.

It is to be understood, however, that even though numerous, characteristics and advantages of the present invention have been set forth in the foregoing description, together with details of the structure and function of the invention, the disclosed is illustrative only, and changes may be made in detail, especially in matters of shape, size, and arrangement of parts within the principles of the invention to the full extent indicated by the broad general meaning of the terms in which the appended claims are expressed.

What is claimed is:

1. An I/O connector, comprising:

a cover defining a receiving space, a notch communicating with the receiving space and a stop portion adjacent to the notch;



**5**

a terminal module received in the receiving space, the terminal module including a dielectric housing and a plurality of terminals held in the housing;  
 a lock member assembled in the housing; and  
 a lock-release button received in the notch for urging the lock member into a released position, the button including a fixing end fixed to the cover and a free operating base swinging about the fixing end, a stop plate projecting from the free operating base for preventing the lock-release button from disengaging the notch;  
 wherein the cover includes a top cover and a bottom cover interlocked with the top cover, the receiving space being defined between the top and the bottom covers; wherein the top cover comprises a side wall, the notch being defined through the side wall of the top cover; wherein the stop portion is recessed from an inner surface of the side wall of the top cover and communicating with the notch, the stop portion engaging with the stop plate of the lock-release button;  
 wherein the lock member includes a retention portion, a press portion bent from the retention portion, a resilient arm flexibly extending from the press portion and a hook portion projecting outwardly from a distal end of the resilient arm;  
 wherein the terminal module defines a groove receiving the lock member, the press portion projecting beyond the groove for being depressed by the lock-release button, the hook portion being exposed to an outside;  
 wherein the terminal module has an internal printed circuit board electrically connecting with the terminals.

**6**

**2.** An I/O connector, comprising:  
 a cover;  
 a terminal module received in the receiving space, the terminal module including a dielectric housing and a plurality of terminals held in the housing for mating with a complementary connector along a lengthwise direction, said housing defining a groove with at least a rear partition walls aside for being not directly outwardly exposed to an exterior in a lateral direction perpendicular to said lengthwise direction; and  
 a lock member including a retention and pressing portion commonly defining a U-shaped structure, a resilient arm extending from the pressing portion with a hook at a free end; wherein  
 the resilient arm of the lock member is initially inserted into the groove in another lateral direction opposite to said lateral direction, and successively the whole lock member is moved forwardly in the lengthwise direction until the U-shaped structure engaged with the rear partition;  
 wherein the pressing portion projects beyond the groove for being depressed by a lock-release button, the hook being exposed to an outside.  
**3.** The I/O connector according to claim **2**, further including a front partition wall for blocking the resilient arm from the exterior in said lateral direction.

\* \* \* \* \*