



US006940392B2

(12) **United States Patent**
Chan et al.

(10) **Patent No.:** **US 6,940,392 B2**
(45) **Date of Patent:** **Sep. 6, 2005**

(54) **METHOD AND APPARATUS FOR VARYING SIGNALS TRANSMITTED BY A TAG**
(75) Inventors: **Joseph S. Chan**, Milpitas, CA (US);
Nikola Cargonja, San Carlos, CA (US)

4,627,248 A 12/1986 Haworth
4,683,461 A 7/1987 Torre 340/551
4,688,244 A 8/1987 Hannon et al.
4,750,197 A 6/1988 Denekamp et al.
4,768,816 A 9/1988 Bakula

(73) Assignee: **Savi Technology, Inc.**, Sunnyvale, CA (US)

(Continued)

(*) Notice: Subject to any disclaimer, the term of this patent is extended or adjusted under 35 U.S.C. 154(b) by 872 days.

FOREIGN PATENT DOCUMENTS

EP 0 467 036 A2 1/1992 G01S/13/74
EP 0 825 554 A1 2/1998 G06K/19/077
EP 0 984 400 A2 3/2000 G07C/5/08
WO WO 01/08116 A2 2/2001
WO WO 01/27891 A1 4/2001
WO WO 01/44831 A1 6/2001

(21) Appl. No.: **09/841,774**

(22) Filed: **Apr. 24, 2001**

(65) **Prior Publication Data**

US 2002/0153996 A1 Oct. 24, 2002

(51) **Int. Cl.**⁷ **H04Q 5/22**

(52) **U.S. Cl.** **340/10.4; 364/467; 375/146; 340/10.1**

(58) **Field of Search** 340/10.4, 10.1, 340/505, 572.1, 10.3, 10.41; 364/467; 375/146; 455/127.1, 115.1, 115.3, 522

OTHER PUBLICATIONS

“Electromagnetic Radiation and How it Affects Your Instruments”, OSHA Field Service Memo, OSHA Cincinnati Laboratory, Cincinnati, Ohio, pp. 1, 8, 9 and 10, May 20, 1990.

(Continued)

Primary Examiner—Michael Horabik
Assistant Examiner—Matsuichiro Shimizu
(74) *Attorney, Agent, or Firm*—Haynes and Boone, LLP

(56) **References Cited**

U.S. PATENT DOCUMENTS

3,639,897 A 2/1972 Teich
3,656,100 A 4/1972 Beltrami
3,665,449 A 5/1972 Elder et al.
3,688,256 A 8/1972 D’Ausilio et al.
3,697,941 A 10/1972 Christ
3,735,335 A 5/1973 Kaplan et al.
3,757,290 A 9/1973 Ross et al.
3,772,669 A 11/1973 Johnston et al.
3,848,243 A 11/1974 Schirmer
3,961,323 A 6/1976 Hartkorn
4,095,872 A 6/1978 Stieff et al.
4,209,787 A 6/1980 Freeny, Jr.
4,262,284 A 4/1981 Stieff et al.
4,529,982 A 7/1985 Karlstrom et al.
4,536,754 A 8/1985 Holce et al.

(57) **ABSTRACT**

An apparatus (10, 240, 300) includes a signpost (11, 241–256, 322, 612, 623, 626–628, 652, 661, 682, 686, 703) which transmits signpost signals (24) that are received by a tag (12, 271–275, 301–316, 395–397, 616–618, 641–643, 653, 656–657, 662–664, 679, 708, 711). The tag in turn transmits radio frequency beacon signals (72) which are received by a reader (13, 261, 319, 521–530). The tag can vary the duration of the beacon signals, for example in dependence on whether it is currently receiving a signpost signal. Further, the tag can dynamically vary the transmission rate and/or transmission power of the beacon signals, for example following receipt of a signpost signal. Varying these parameters can facilitate compliance with governmental regulations.

20 Claims, 10 Drawing Sheets

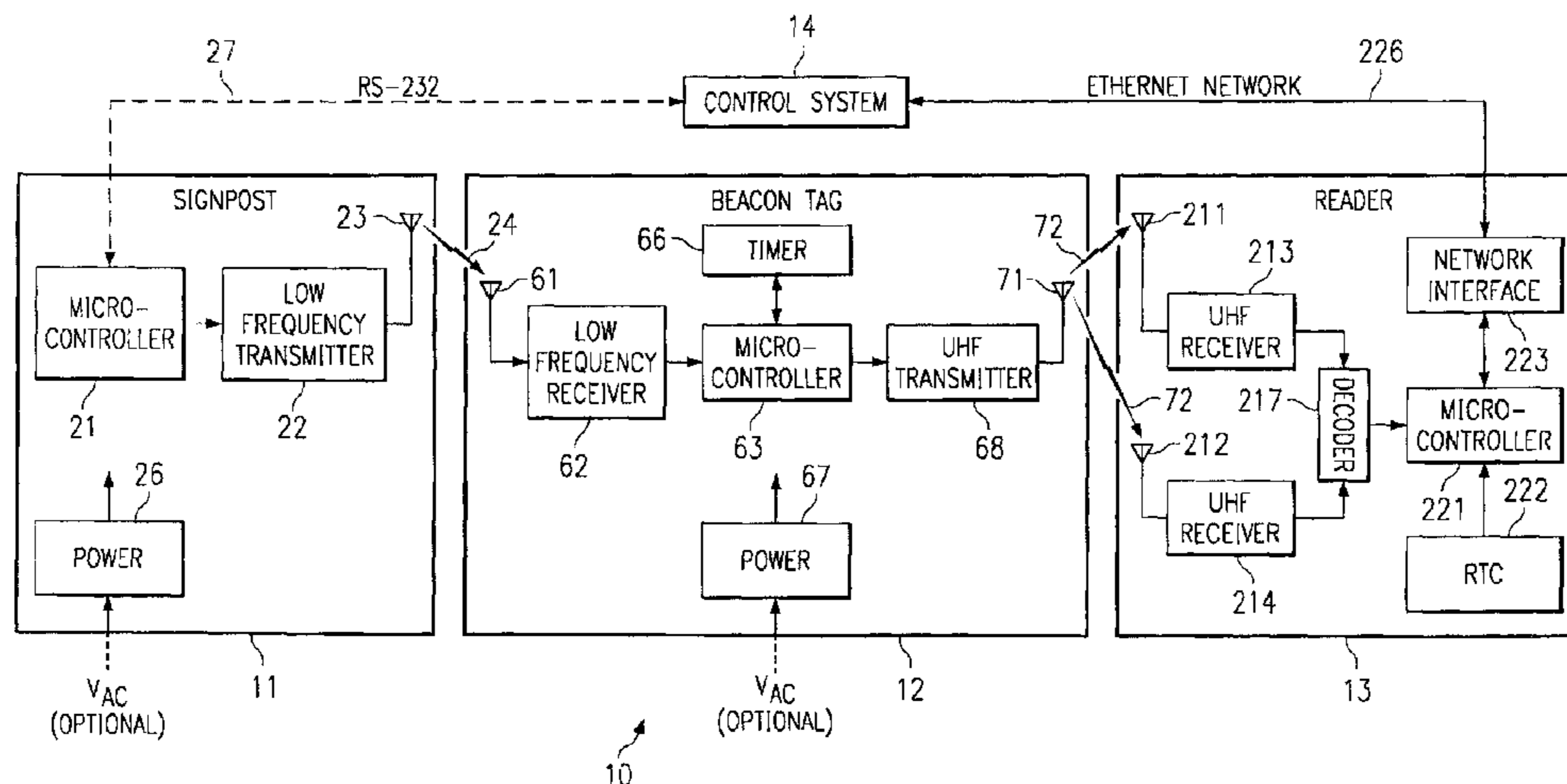

U.S. PATENT DOCUMENTS

4,811,578 A 3/1989 Masoncup et al.
 4,811,977 A 3/1989 Swift et al.
 4,816,803 A 3/1989 Brown
 4,853,692 A 8/1989 Wolk et al.
 4,877,276 A 10/1989 Pastva
 4,883,295 A 11/1989 Kesselman
 4,920,334 A 4/1990 DeVolpi
 4,946,210 A 8/1990 Fuehrer
 4,990,890 A 2/1991 Newby
 4,996,909 A 3/1991 Vache et al.
 5,005,883 A 4/1991 Guiler
 5,025,253 A 6/1991 DiLullo et al.
 5,050,794 A 9/1991 Wischusen, III
 5,056,837 A 10/1991 Fuehrer
 5,097,253 A 3/1992 Eschbach et al.
 5,120,097 A 6/1992 Fattori et al.
 5,125,700 A 6/1992 Fattori et al.
 5,127,687 A 7/1992 Guiler
 5,189,396 A 2/1993 Stobbe
 5,247,564 A 9/1993 Zicker
 5,284,036 A 2/1994 Rosenbaum
 5,347,274 A 9/1994 Hassett
 5,422,627 A 6/1995 Tap et al. 340/542
 5,443,190 A 8/1995 Cucheran et al.
 5,490,079 A * 2/1996 Sharpe et al. 705/418
 5,572,191 A 11/1996 Lundberg 340/572
 5,594,738 A 1/1997 Crisler et al.
 5,627,517 A 5/1997 Theimer et al.
 5,631,642 A 5/1997 Brockelsby et al.
 5,656,996 A 8/1997 Houser
 5,686,902 A 11/1997 Reis et al.
 5,774,876 A 6/1998 Woolley et al.
 5,793,290 A 8/1998 Eagleson et al.
 5,804,810 A 9/1998 Woolley et al.
 5,892,441 A 4/1999 Woolley et al.
 5,959,568 A 9/1999 Woolley
 5,977,913 A 11/1999 Christ
 6,034,603 A 3/2000 Steeves 340/572.1
 6,067,476 A 5/2000 Siler
 6,069,563 A 5/2000 Kadner et al.
 6,094,164 A 7/2000 Murphy
 6,140,956 A 10/2000 Hillman et al.

6,243,005 B1 6/2001 Haimovich et al.
 6,281,793 B1 8/2001 Haimovich et al.
 6,294,953 B1 9/2001 Steeves 329/341
 6,298,306 B1 10/2001 Suarez et al.
 6,339,745 B1 1/2002 Novik
 6,539,050 B1 * 3/2003 Lee et al. 375/146
 6,765,484 B2 * 7/2004 Eagleson et al. 340/505

OTHER PUBLICATIONS

Straw, R. Dean, editor, "The ARRI, Antenna Book", The American Radio Relay League, Inc., Newington, Connecticut, title page, copyright page and pp. 2-6 and 2-7.
 Kraus, John D., "Antennas", Second Edition, McGraw-Hill, Inc., New York, New York, title page, copyright page, and pp. 60-61, 1988.
 Lancaster, Don, "Tech Musings", Synergetics, Thatcher, Arizona, pp. 138.1-138.6, Jul. 1999.
 Roderick E. Thorne, Philip J. Keieshian, Timothy R. Redler, Joseph S. Chan, and Nikola (nmi) Cargonja, U.S. Appl. No. 60/332,480 filed Nov. 9, 2001.
 Roderick E. Thorne, Philip J. Keieshian, Timothy R. Redler, Joseph S. Chan, and Nikola (nmi) Cargonja, U.S. Appl. No. 10/133,270 filed Apr. 26, 2002.
 Arthur E. Anderson III, James G. Eagleson, and William E. Blasdell, U.S. Appl. No. 60/230,728 filed Sep. 7, 2000.
 James G. Eagleson, Arthur E. Anderson III, Timothy K. Brand, Nikola Cargonja, and Ravindra U. Rajapakse, U.S. Appl. No. 09/841,780, filed Apr. 24, 2001.
 James G. Eagleson, William E. Blasdell, Arthur E. Anderson III, and Nikola Cargonja, U.S. Appl. No. 09/841,782, filed Apr. 24, 2001.
 James G. Eagleson, Joseph S. Chan, and Nikola Cargonja, U.S. Appl. No. 09/841,776, filed Apr. 24, 2001.
 "KXU-LFTX1 Transceiver", Cover Sheet with Block Diagram (1 sheet) and Schematic (1 sheet), submitted to FCC on Jul. 29, 1999, by RF Technologies.
 "KXU-LUXP1 Transponder", Cover Sheet with Block Diagram (1 sheet) and Schematic (1 sheet), submitted to FCC on Jul. 28, 1999 by RF Technologies.

* cited by examiner

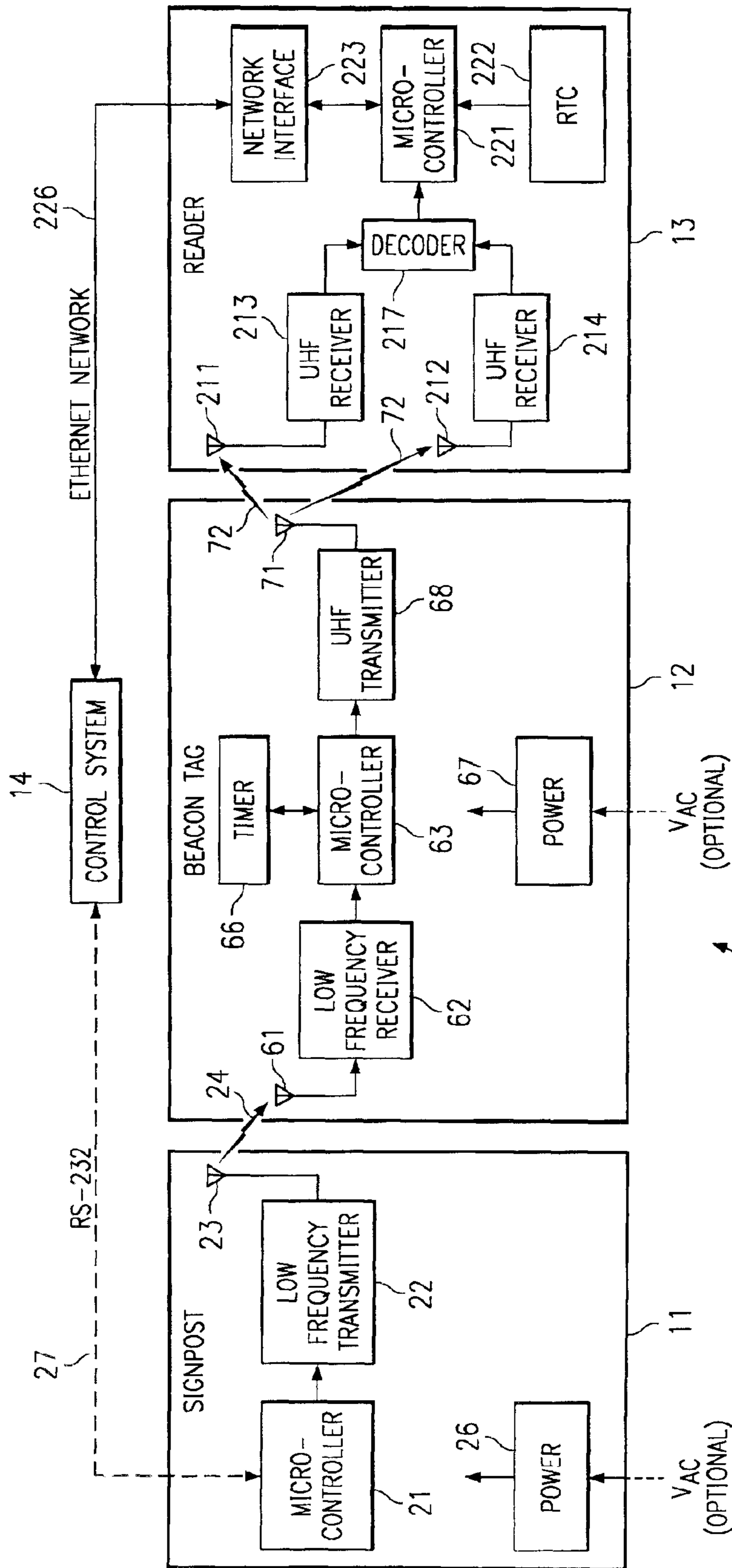

10 FIG. 1

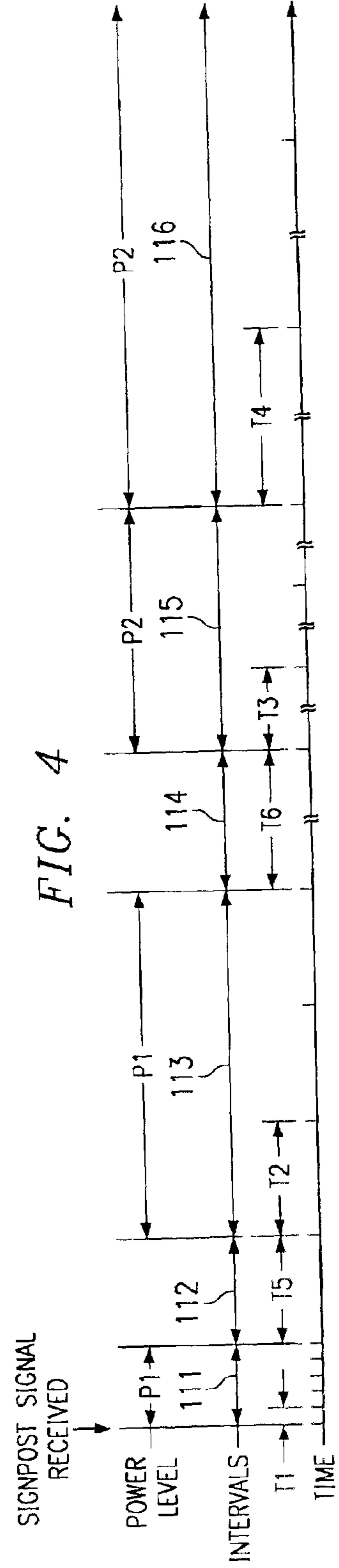
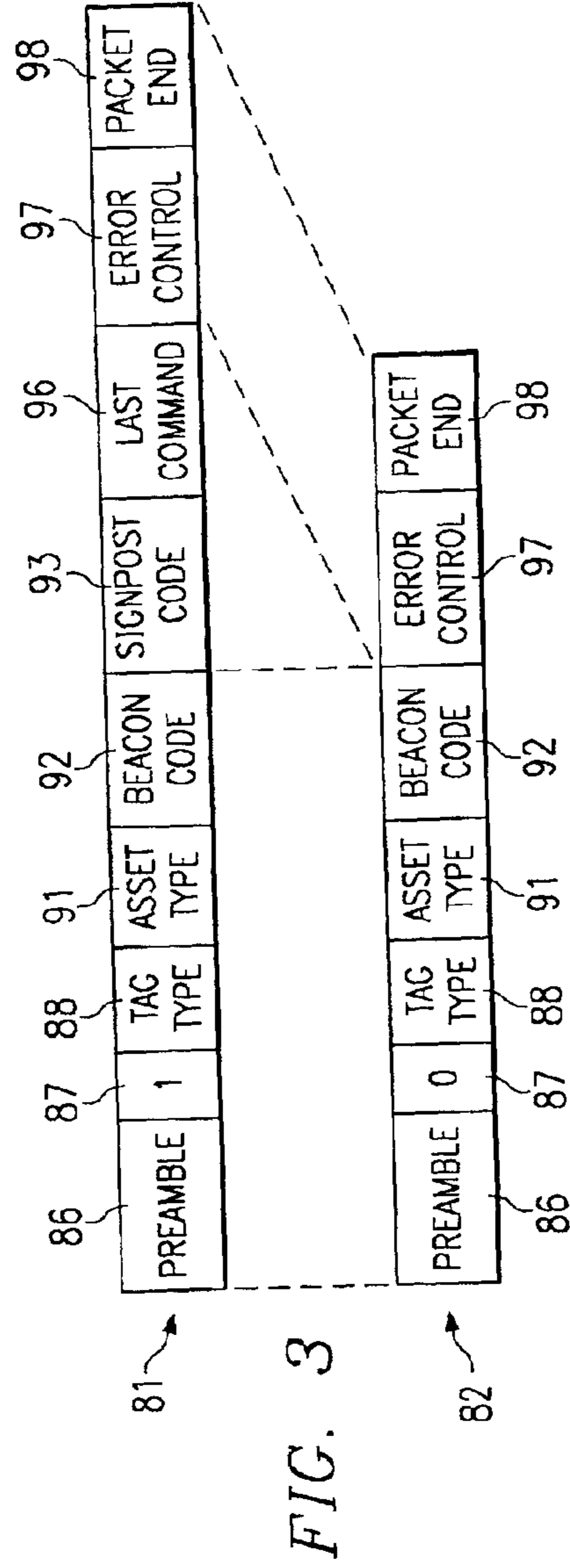
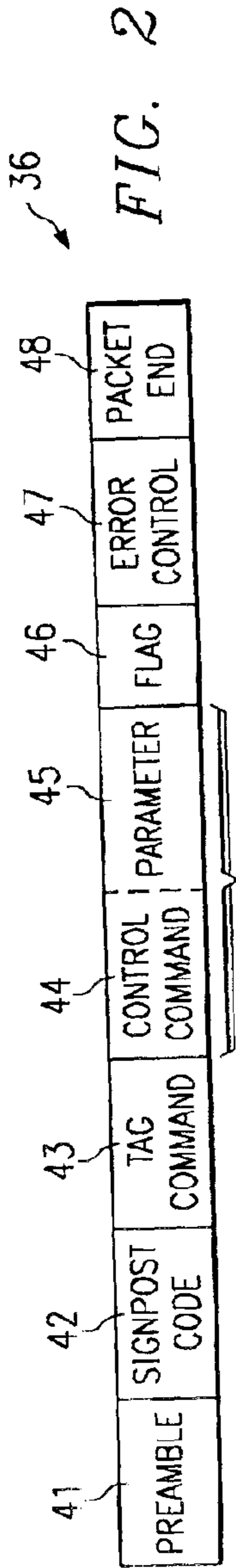

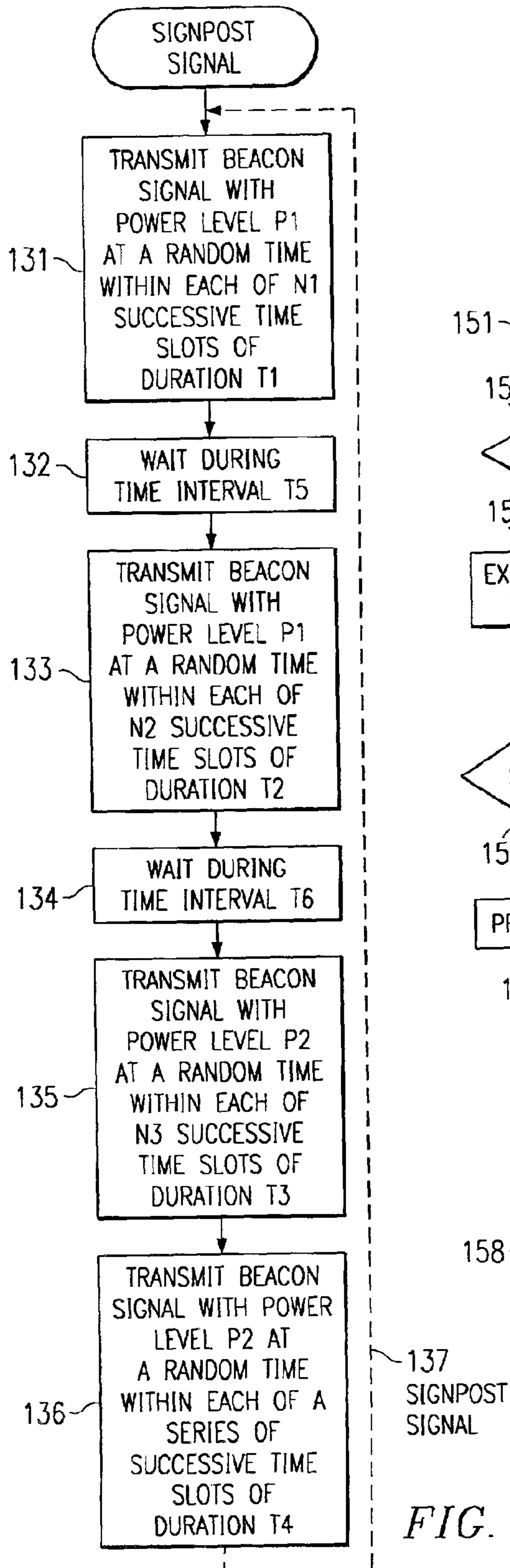

FIG. 5

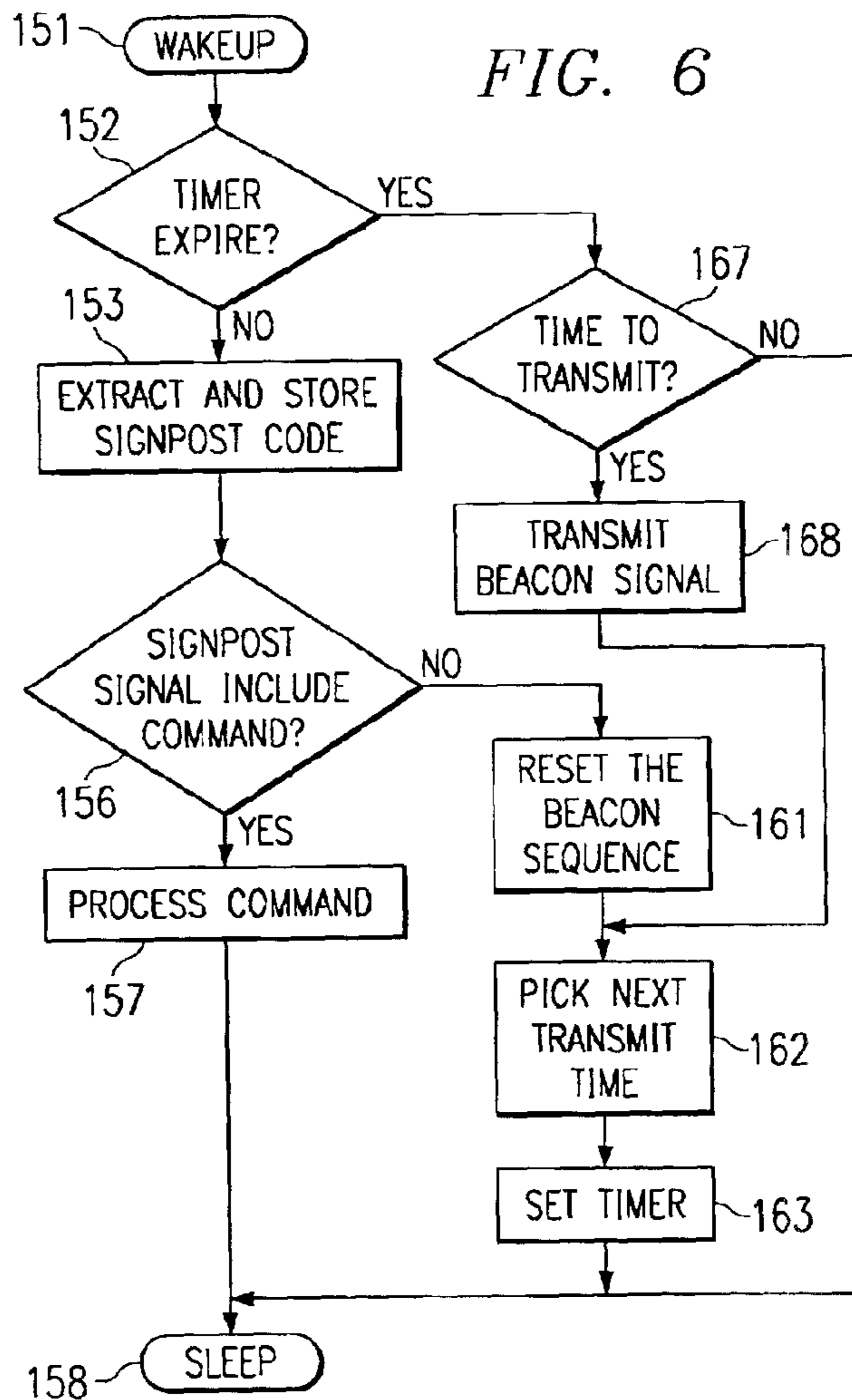

FIG. 6

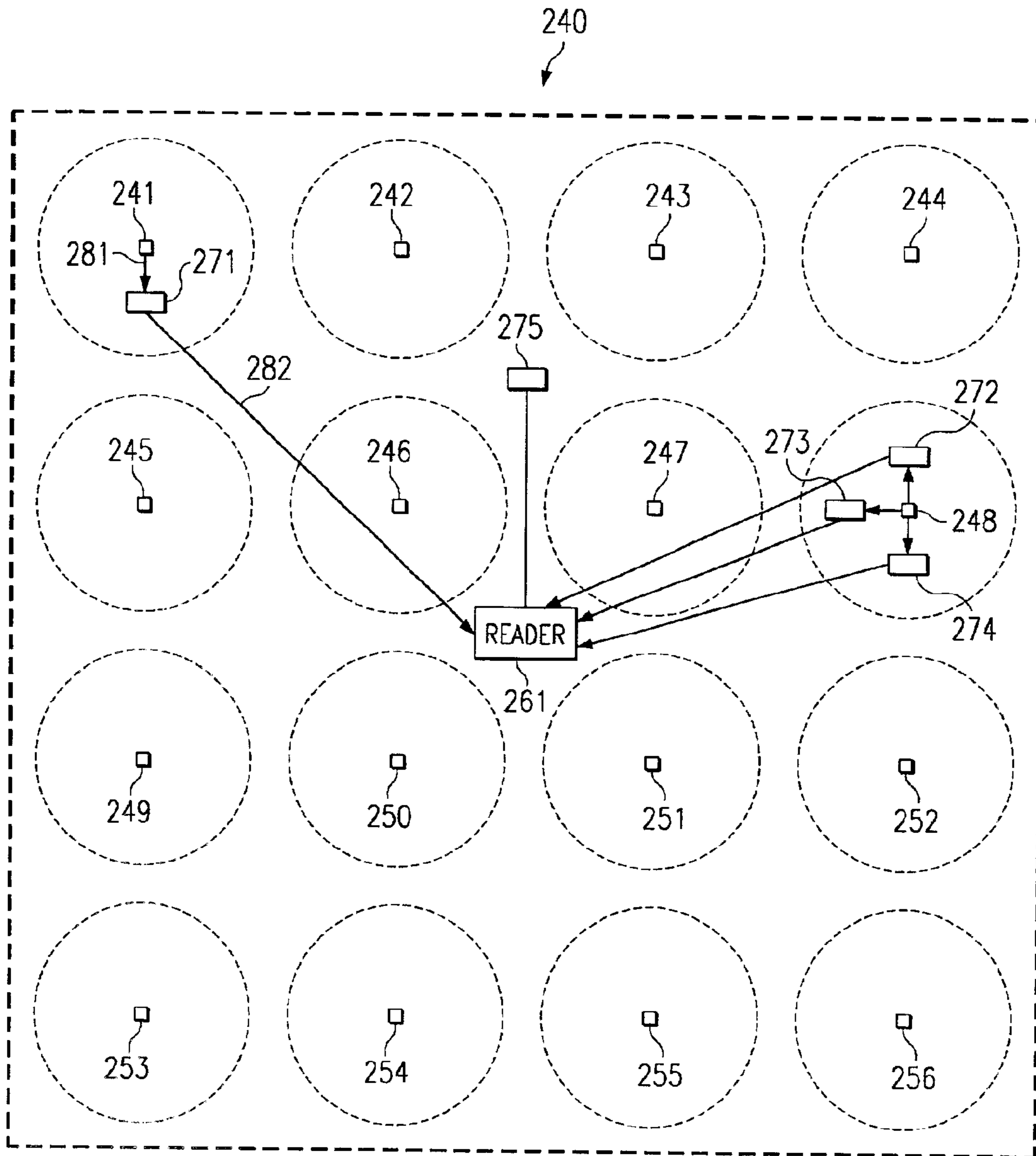

FIG. 7

FIG. 8

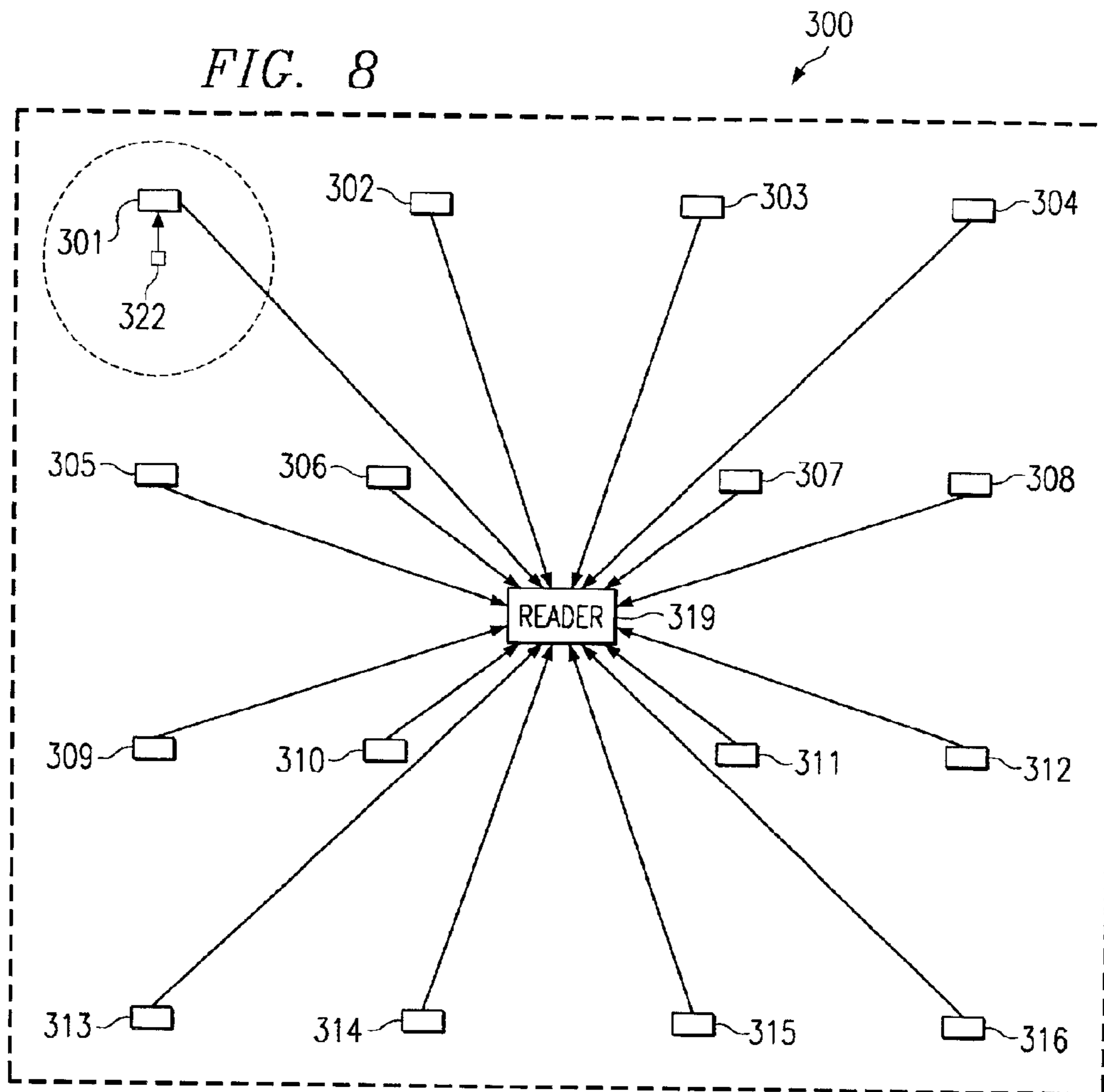
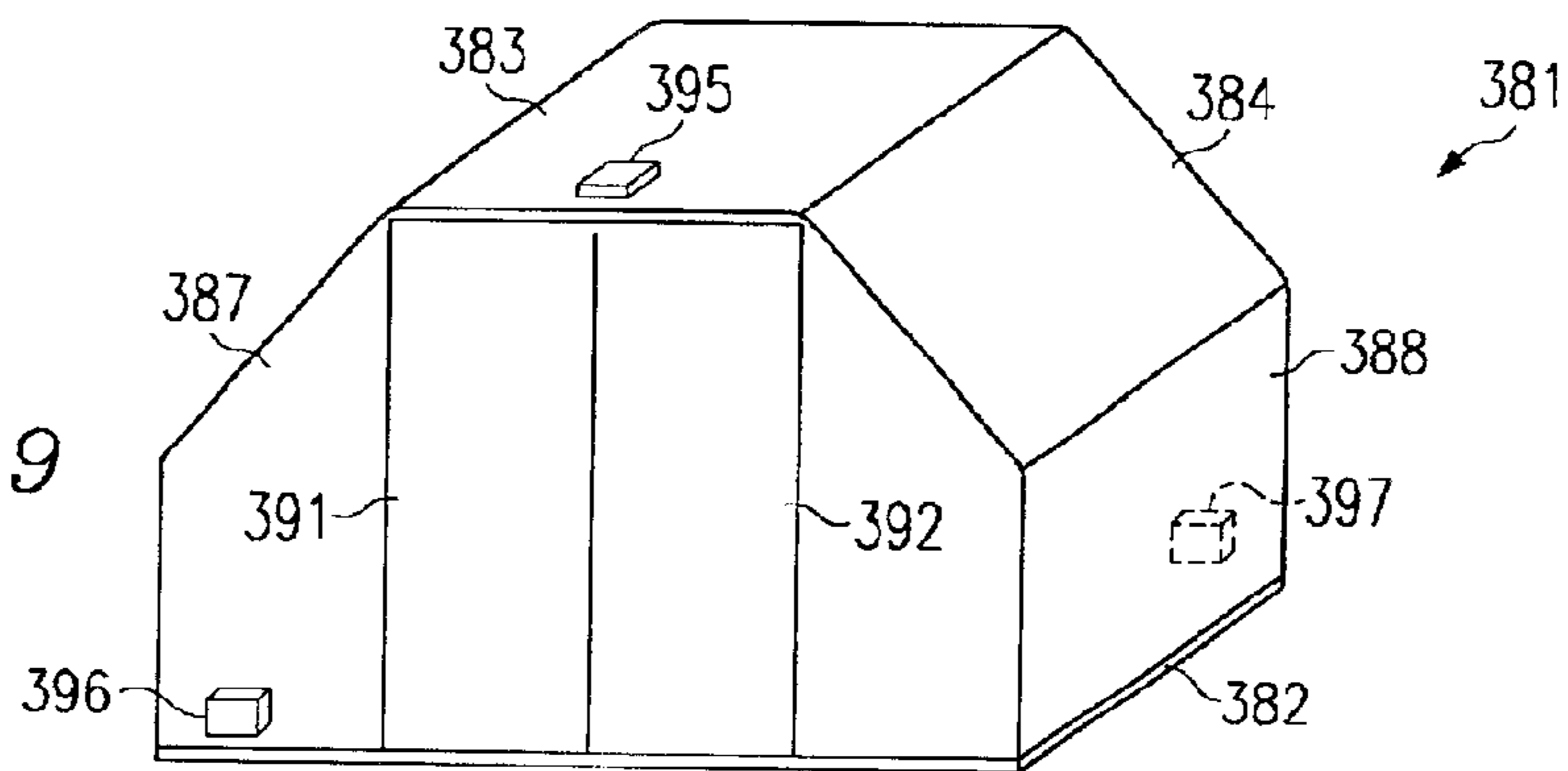
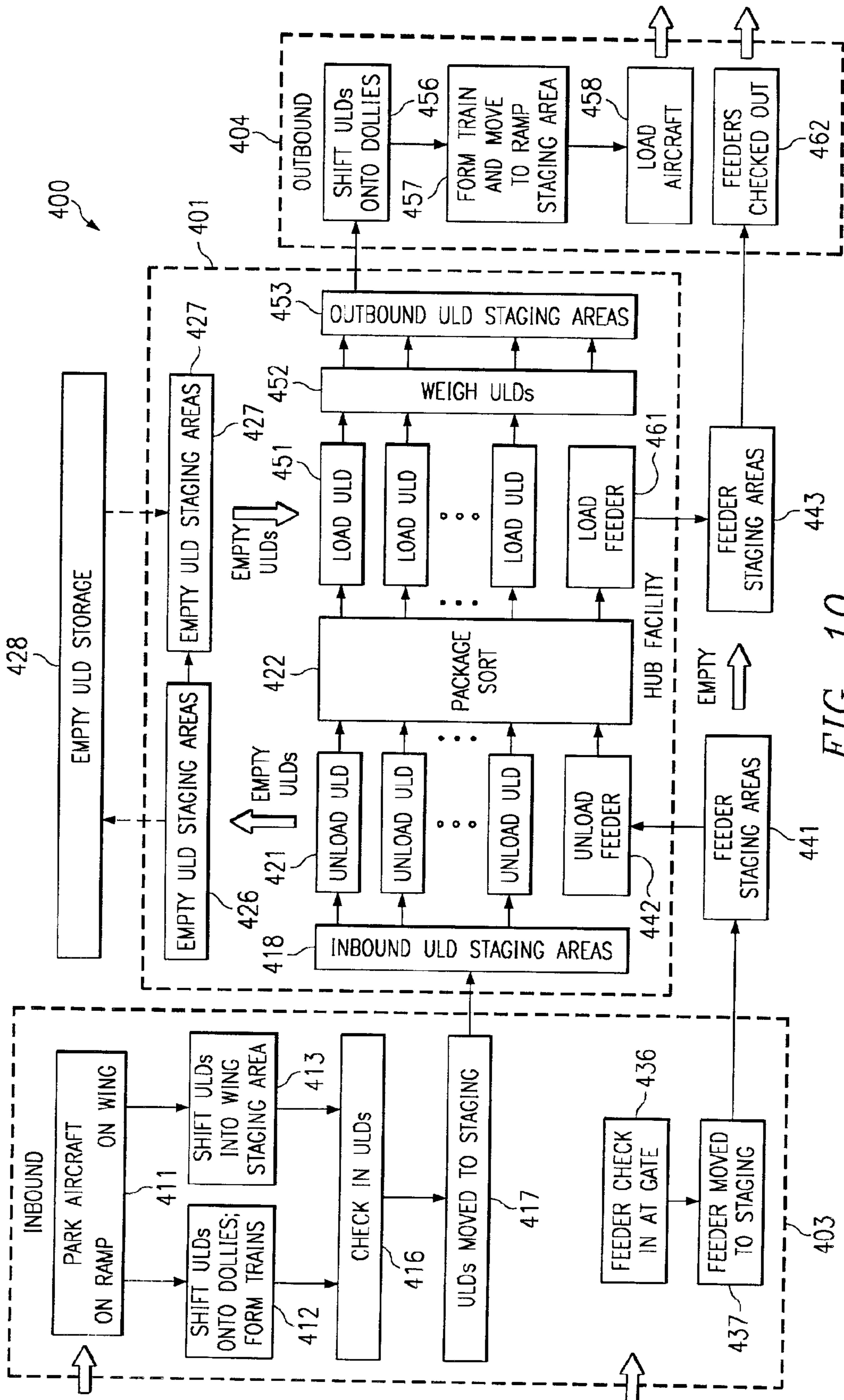

FIG. 9





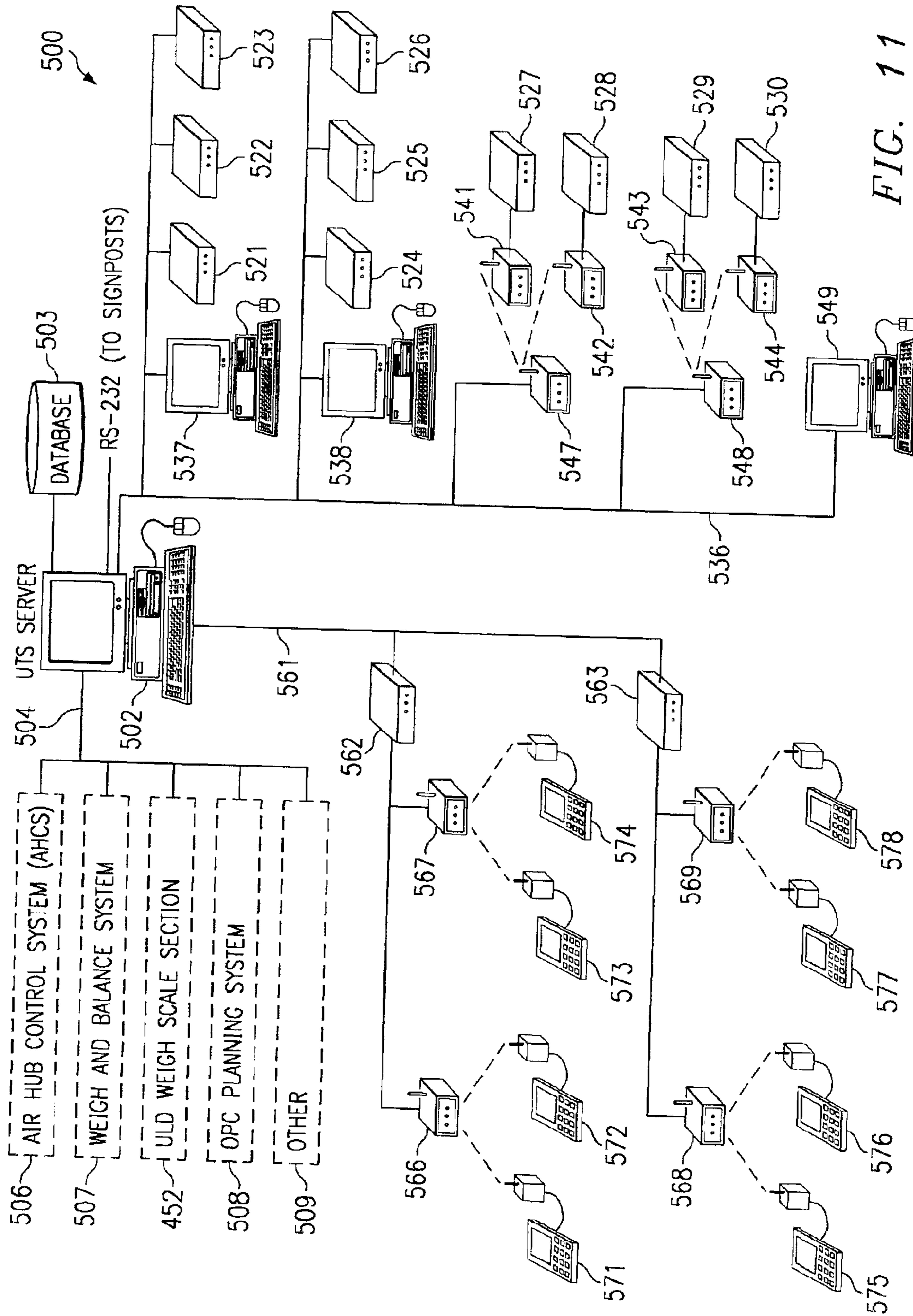

FIG. 11

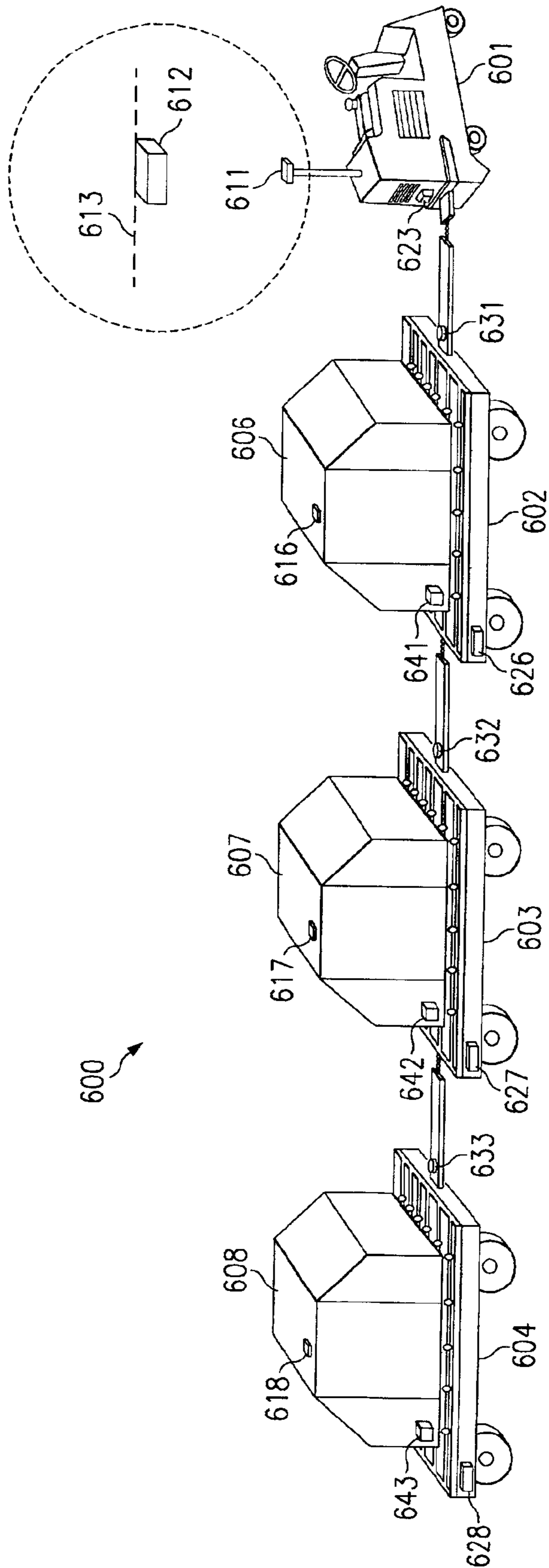

FIG. 12

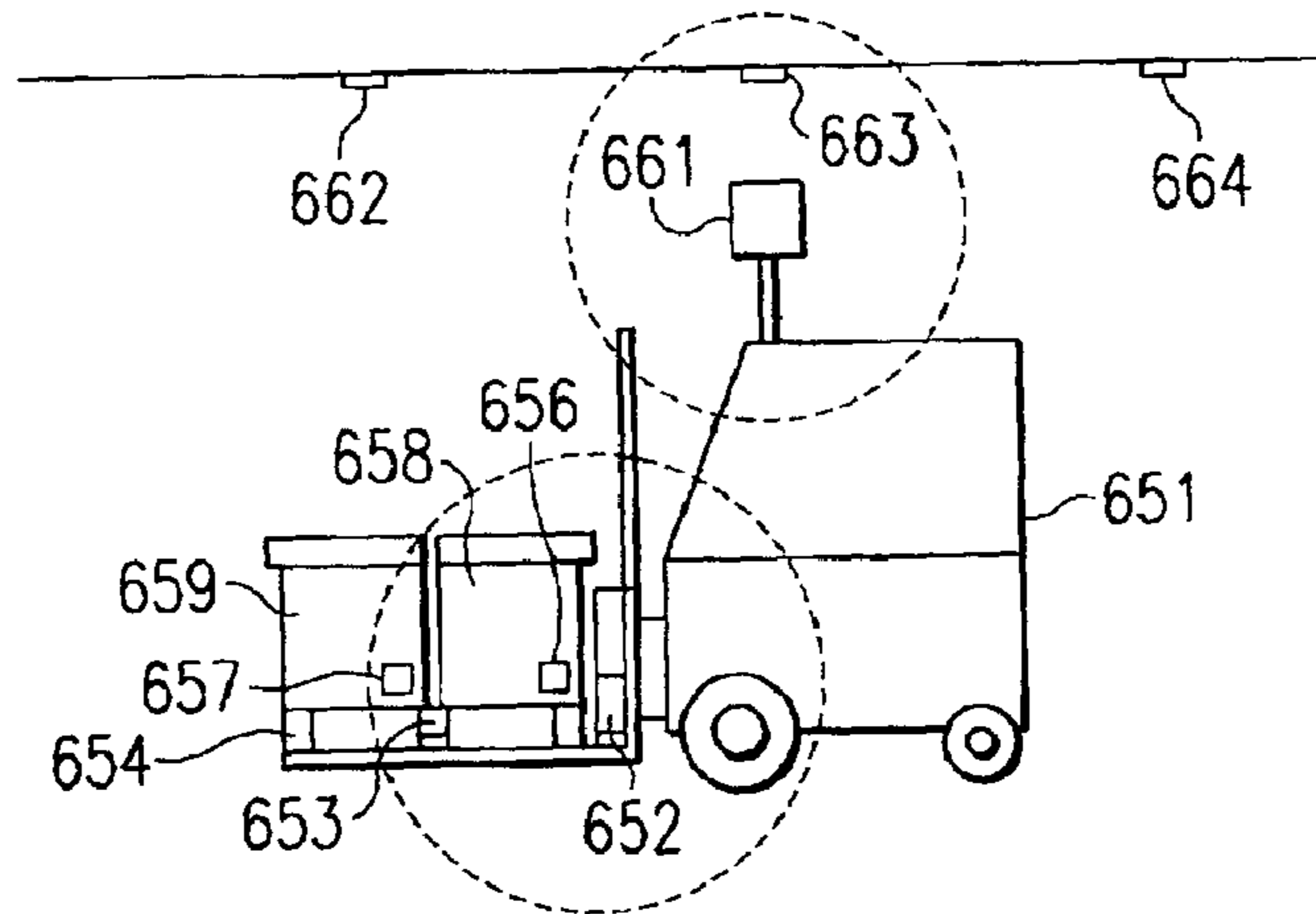

FIG. 13

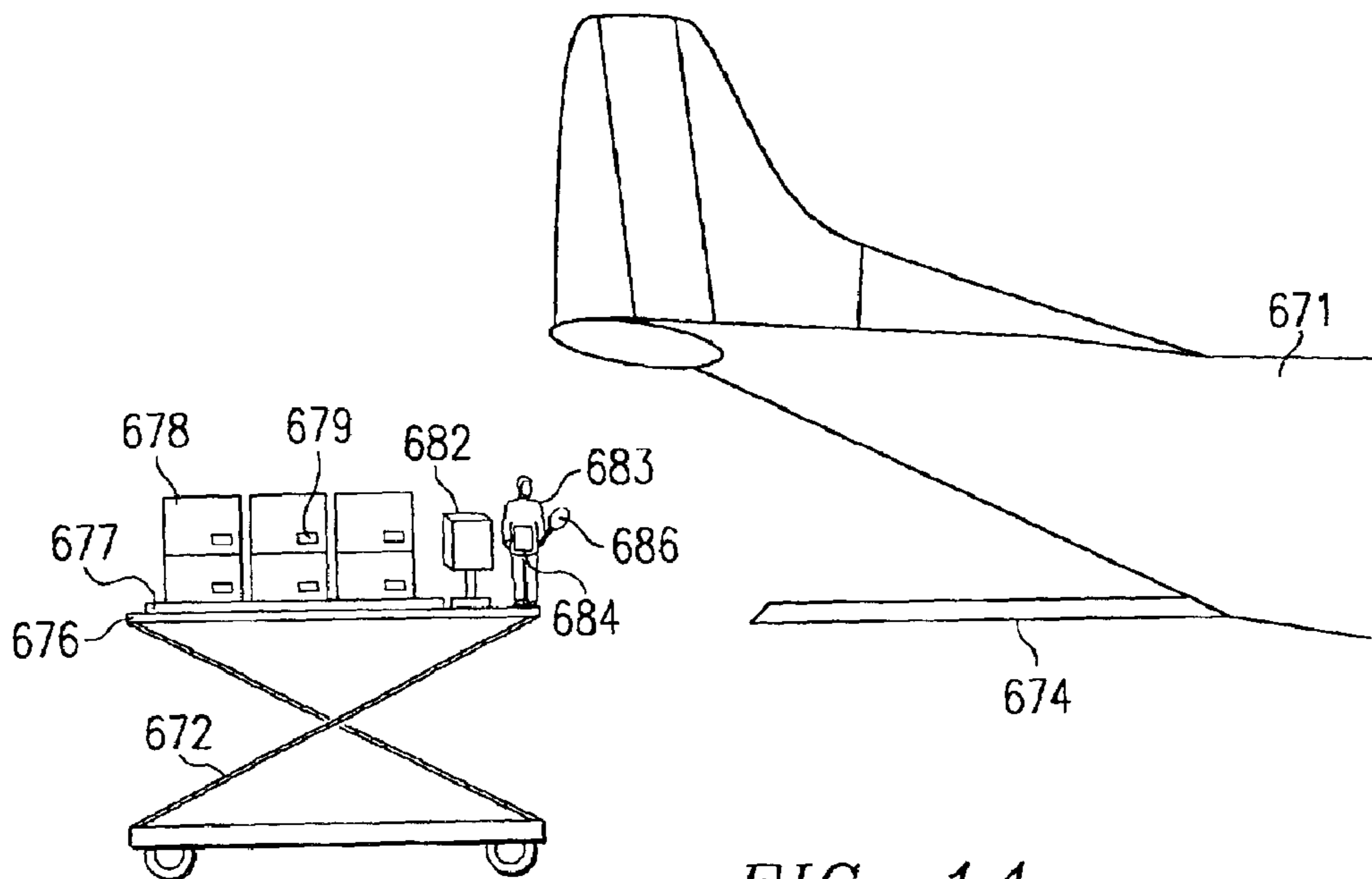

FIG. 14

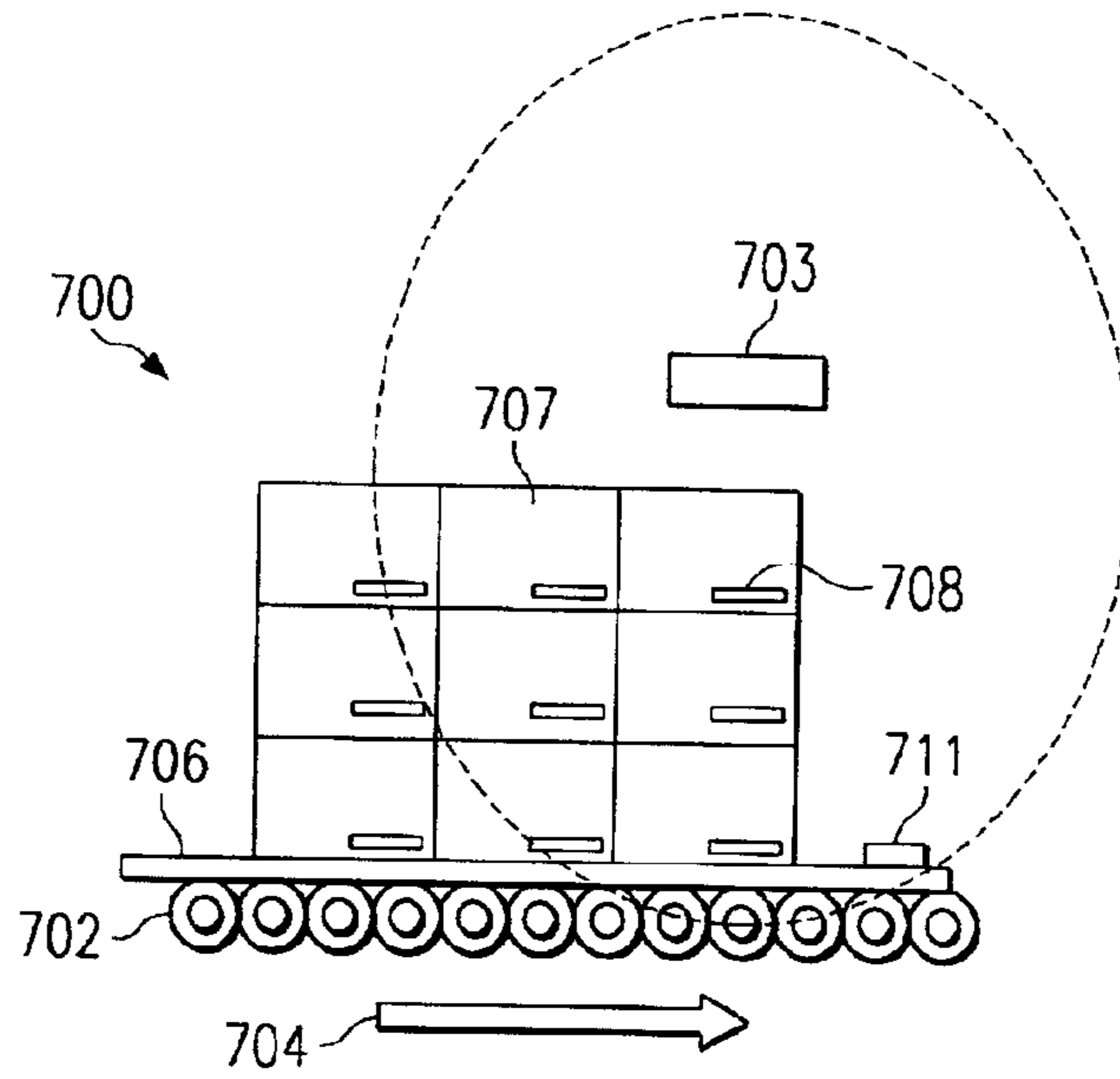

FIG. 15

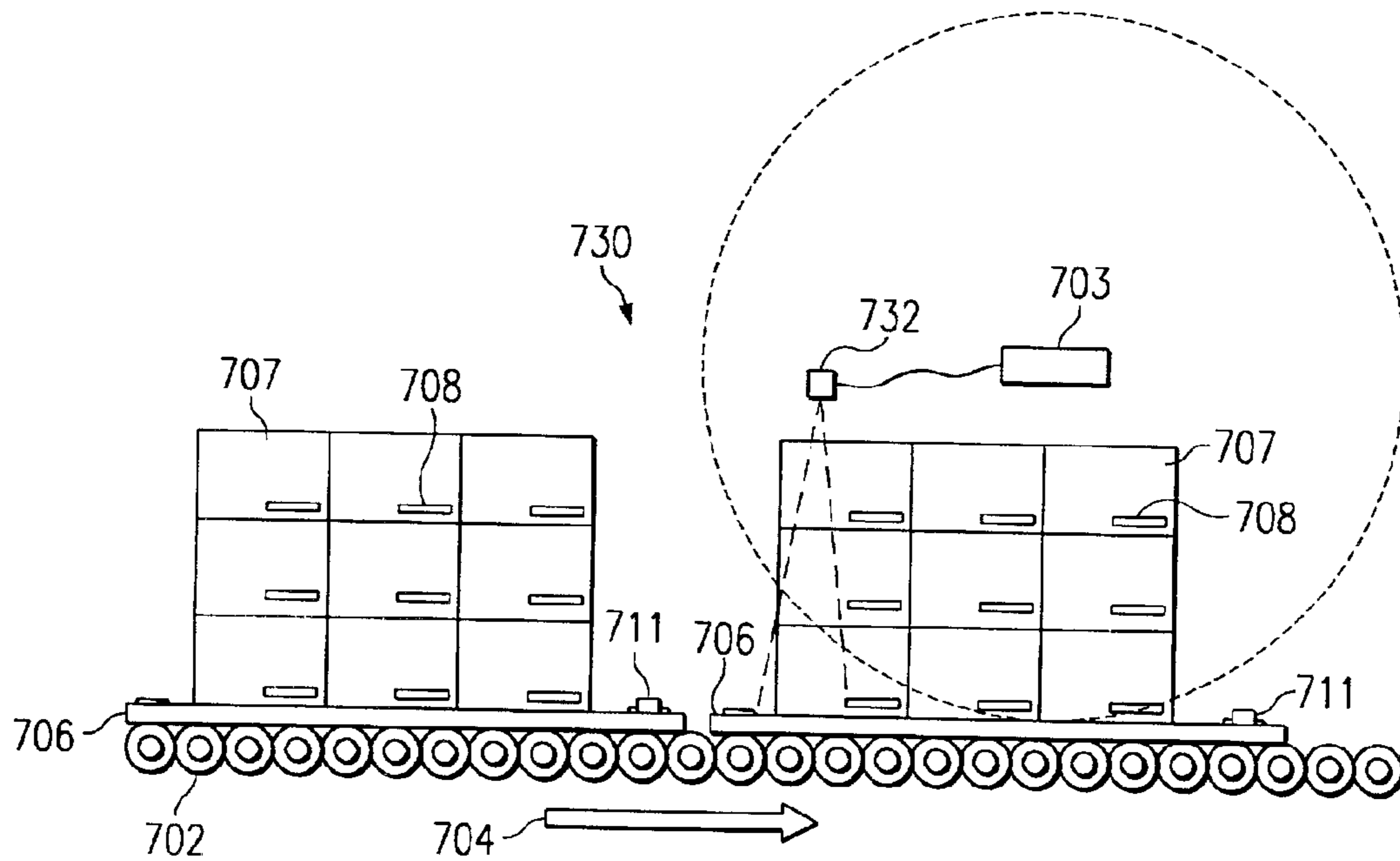

FIG. 16

METHOD AND APPARATUS FOR VARYING SIGNALS TRANSMITTED BY A TAG

STATEMENT REGARDING COPYRIGHT RIGHTS

A portion of this patent disclosure involves material which is subject to copyright protection. The copyright owner has no objection to the facsimile reproduction by anyone of the patent document or the patent disclosure, as it appears in the Patent and Trademark Office patent file or records, but otherwise reserves all copyright rights whatsoever.

TECHNICAL FIELD OF THE INVENTION

This invention relates in general to techniques for tracking mobile items, and more particularly, to a method and apparatus for tracking items using radio frequency identification tags.

BACKGROUND OF THE INVENTION

According to an existing technique for tracking mobile items, a device known as a tag is mounted on the item, and communicates by radio frequency signals with a central receiver, which is commonly known as a reader. Systems of this basic type have been generally adequate for their intended purposes, but have not been satisfactory in all respects.

In this regard, the manner in which a tag transmits radio frequency information can create issues relating to compliance with governmental regulations, because governmental regulations often effect a balancing between factors such as transmission length, transmission power and transmission rate. In existing tags, the tag design involves selection of a predetermined balance between transmission duration, transmission power, and transmission length, and then operation of the tag is carried out using this predetermined balance.

SUMMARY OF THE INVENTION

From the foregoing, it may be appreciated that a need has arisen for a method and apparatus for tracking items using radio frequency identification technology, in a manner which permits variation of certain characteristics of the transmitted signals. According to a first form of the present invention, a method and apparatus are provided to address this need and involve: receiving in a receiver section of a tag wireless signpost signals that each include a signpost code; and transmitting from a transmitter section of the tag wireless beacon signals which each include a beacon code associated with the tag. The transmitting activity includes: causing the transmitter section to be responsive to receipt by the receiver section of a respective signpost signal for including in at least one beacon signal the signpost code from the received signpost signal; and causing the transmitter section to transmit the beacon signals in a selected one of first and second formats which are different, the transmitter section using the first format in response to receipt of one of the signpost signals and using the second format in response to the absence of receipt of any of the signpost signals for a specified time interval, the first format including a signpost field containing the signpost code from the most recently received signpost signal, and the second format lacking the signpost field and being shorter in length than the first format.

A different form of the present invention involves: receiving in a receiver section of a tag wireless signpost signals that each include a signpost code; and transmitting from a transmitter section of the tag wireless beacon signals which each include a beacon code associated with the tag. The transmitting activity includes: causing the transmitter section to be responsive to receipt by the receiver section of a respective signpost signal for including in at least one beacon signal the signpost code from the received signpost signal; and causing the transmitter section to be responsive to receipt by the receiver section of one of the signpost signals for automatically effecting variation in a predetermined manner of at least one of a transmission power level and a transmission rate for the beacon signals.

BRIEF DESCRIPTION OF THE DRAWINGS

FIG. 1 is a block diagram of an apparatus which embodies features of the present invention, and which includes a signpost, a beacon tag, a reader, and a control system;

FIG. 2 is a diagrammatic view of a digital word which is transmitted by the signpost of FIG. 1;

FIG. 3 is a diagrammatic view of two different digital words, either of which can be transmitted by the beacon tag of FIG. 1;

FIG. 4 is a diagram showing a sequence and timing with which the beacon tag of FIG. 1 transmits beacon signals;

FIG. 5 is a flowchart showing in a different form the beacon signal sequence which is depicted in FIG. 4;

FIG. 6 is a high-level flowchart showing still other aspects of the operation of the beacon tag of FIG. 1;

FIG. 7 is a diagrammatic top view of a system which represents one practical application for an apparatus of the type shown in FIG. 1;

FIG. 8 is a diagrammatic top view similar to FIG. 7, but showing a system which represents another practical application for an apparatus of the type shown in FIG. 1;

FIG. 9 is a diagrammatic perspective view of one type of container which can be used in association with the invention, and which bears three beacon tags of the type shown in FIG. 1;

FIG. 10 is a diagrammatic top view of an installation which represents one example of a practical application of a system of the type shown in FIG. 1;

FIG. 11 is a diagrammatic view of selected portions of a system which embodies the invention and which is suitable for use in association with the installation of FIG. 10;

FIG. 12 is a diagrammatic view of a train which includes a tractor, three trailers, and a container on each trailer, and which embodies certain aspects of the present invention;

FIG. 13 is a diagrammatic side view of a forklift that carries two signposts of the type shown in FIG. 1, a ceiling bearing several beacon tags of the type shown in FIG. 1, and several items carried by the forklift which each bear a beacon tag of the type shown in FIG. 1;

FIG. 14 is a diagrammatic side view of the tail section of an airplane, and a loader which can be used to load or unload the airplane;

FIG. 15 is a diagrammatic side view of an apparatus which includes a conveyor, a signpost of the type shown in FIG. 1 that is mounted above the conveyor, and several items that are traveling along the conveyor on a palette, and that each have thereon a beacon tag of the type shown in FIG. 1; and

FIG. 16 is a diagrammatic sectional side view of an apparatus which is an alternative embodiment of the appa-

ratus shown in FIG. 7, in that it includes the addition of a sensor which can affect the operation of the signpost

DETAILED DESCRIPTION OF THE INVENTION

FIG. 1 is a block diagram of an apparatus 10 which embodies features of the present invention. The apparatus 10 includes a signpost 11, a beacon tag 12, a reader 13, and a control system 14. The apparatus 10 actually includes many signposts of the type shown at 11, many tags of the type shown at 12, and several readers of the type shown at 13. However, for clarity in explaining certain fundamental aspects of the present invention, FIG. 1 shows only one signpost 11, one tag 12, and one reader 13.

Focusing first on the signpost 11, the signpost 11 includes a microcontroller 21. Persons skilled in the art are familiar with the fact that a microcontroller is an integrated circuit which includes a microprocessor, a read only memory (ROM) containing a computer program and static data for the microprocessor, and a random access memory (RAM) in which the microprocessor can store dynamic data during system operation. The signpost 11 also includes a low frequency transmitter 22 which is controlled by the microcontroller 21, and which transmits a low frequency signpost signal 24 through an antenna 23. The transmitter 22 is of a type known to those skilled in the art, and is therefore not illustrated and described here in detail. The antenna 23 of the signpost 11 can be a ferrite core and/or planar coil antenna of a known type. The antenna 23 is configured to transmit an omni-directional signal, but it will be recognized that the antenna could alternatively be configured so as to transmit a signal which is to some extent directional.

In the embodiment of FIG. 1, the transmitter 22 generates the signpost signal 24 by effecting amplitude modulation of a carrier signal, which can have a frequency within a range of approximately 30 KHz to 30 MHz. In the embodiment of FIG. 1, and with due regard to compliance with governmental regulations of various countries regarding electromagnetic emissions, the carrier frequency is selected to be 132 KHz, but could alternatively be some other frequency, such as 125 KHz or 13.56 MHz. A further consideration in the selection of the indicated frequency range is that the signpost signals 24 will exhibit near field characteristics. The localized nature of signals in this frequency range helps to facilitate compliance with governmental regulations in the specific context of the present invention, and also helps to minimize reception of these signals by other tags of the type shown at 12, which are in the general vicinity of the signpost 11 but are beyond an intended transmission range of the signpost signals 24. As known by persons skilled in the art, a signal with near field characteristics has a roll-off which is roughly three times higher than the roll-off for a signal with far field characteristics. Consequently, the signpost signals 24 intentionally have a relatively short transmission range, which in the disclosed embodiment is adjustable but is typically about four to twelve feet. Due to the fact that the signpost signals 24 exhibit near field characteristics, the transmission and reception of the signpost signals 24 may be viewed as more of a magnetic coupling between two antennas, rather than a radio frequency coupling.

The signpost 11 also includes a power source 26, which would typically be a battery that is capable of powering the signpost for several years. However, in situations where the signpost 11 is stationary rather than mobile, it is alternatively possible to power the signpost 11 from a standard source of 120 VAC power, as indicated diagrammatically in FIG. 1 by a broken line.

As shown diagrammatically by a broken line 27 in FIG. 1, the microcontroller 21 of the signpost 11 can optionally be coupled to the control system 14 by a standard RS-232 serial interface. The RS-232 interface would typically be present only where the signpost 11 is fixedly mounted in a stationary location, as opposed to a situation where the signpost 11 is mounted on some form of mobile device. Alternatively, the RS-232 interface could couple the signpost 11 to the reader 13, because the reader 13 would typically be closer to the signpost 11 than the control system 14. In that case, when the control system 14 wished to communicate with the signpost 11, it would do so through the reader 13. Although the interface 27 in FIG. 1 is an RS-232 interface, it will be recognized that it could alternatively be some other suitable interface, such as an Ethernet interface, an RS-485 interface, or a wireless interface.

The signpost 11 transmits the signpost signal 24 at periodic intervals. The time interval between successive transmissions may be configured to be relatively small, such as 100 msec, or relative large, such as 24 hours, depending on the particular circumstances of a given signpost 11 relative to the rest of the system. Each signpost signal 24 transmitted by the signpost 11 includes several different elements of information, which will now be discussed in association with FIG. 2.

More specifically, FIG. 2 is a diagrammatic view of a digital word 36 having several different fields of information which are discussed below. The bits of the digital word 36 are transmitted in the signpost signal 24 by serially modulating the bits of the word 36 onto the 132 Kz carrier using amplitude modulation, as mentioned above. The bits of the words 36 are transmitted serially from left to right in FIG. 2. The first field is a preamble 41, which is a predefined pattern of bits that will allow a device receiving the signal to recognize that the signpost signal is beginning, and to synchronize itself to the signpost signal. In the disclosed embodiment, the preamble is approximately 8 bits, but the specific number of bits can vary in dependence on characteristics of the particular receiver which is expected to be used to receive the signpost signal.

The next field 42 in the word 36 is a signpost code, which in the disclosed embodiment is a 12-bit integer value that uniquely identifies the particular signpost 11 which is transmitting the word 36. As mentioned above, the system 14 may have a number of signposts 11, and the use of different signpost codes 42 by different signposts permits the system to distinguish signpost signals transmitted by one signpost from those transmitted by another, in a manner discussed in more detail later.

This does not mean that this system could never have two signposts with exactly the same signpost code. For example, two signposts might be stationarily mounted in close proximity to each other and configured to independently transmit effectively identical signpost signals 24, not in synchronism, in order to increase the likelihood that a receiver will pick up the signpost signal from at least one of the two signposts. In effect, this represents a level of redundancy, in order to increase reliability and accuracy. A different possible scenario is that two signposts 11, which are fixedly mounted at respective locations remote from each other, could conceivably use exactly the same signpost code 42. For example, if they each communicated with the control system 14 through a respective different reader 13, the control system 14 would have the capability to distinguish them from each other.

The next field in the word 36 of FIG. 2 is a tag command 43, which is a command to the beacon tag 12 that can affect

the operation of the beacon tag **12**. The tag command field **43** is a 2-bit field. Since the purpose of the tag command field **43** is to affect the operation of the beacon tag **12**, a discussion of specific examples of these commands will be deferred until after the beacon tag **12** has been described in more detail. The next two fields in the word **36** are a control command **44** and a parameter **45**, which are related. In the disclosed embodiment, the control command **44** is a 4-bit field, and a parameter **45** is an 8-bit field. The control command **44** is similar to the tag command **43**, to the extent that they each instruct the tag **12** to do something. The difference is that the control commands **44** generally requires an accompanying parameter **45**, whereas the tag commands **43** do not use parameters. A discussion of the control commands **44** is deferred until later, after the tag **12** has been discussed in more detail.

The next field in the word **36** is an extension flag **46**, which is a 1-bit field. In the disclosed embodiment, this field is always a binary "0" for the word format **36** of FIG. 2. It is provided for the purpose of facilitating future compatibility. For example, if it was necessary at some future time to modify the format of the word **36**, the flag **46** would be set to a binary "1" in each word having the new format, so that a device receiving the signpost signal **24** could determine whether the word **36** received in that signal had the original format shown at **36** in FIG. 2, or the new format.

The next field in word **36** is an error control field **47**. Since communications between the signpost **11** and other devices are essentially one-way transmissions, and since many applications for the apparatus **10** of FIG. 1 involve environments that have relatively high noise levels, it is important for a receiving device to be able to evaluate whether the word **36** it received in a signpost signal is correct, or whether it has errors. Consequently, the error control field **47** is included to provide a degree of forward error correction (FEC). In the disclosed embodiment, the error control field **47** contains eight parity bits, but the number of parity bits may be different if the total number of bits in the word **36** is changed, or if a different one of several well-known parity schemes is selected for use. In addition to use of the error control field **47**, the overall level of reliability and accuracy can also be increased by causing a device which receives the signpost signal **24** to save and compare two successive transmissions of a given signpost signal **24**, in order to verify that they are completely identical.

The last field in the word **36** is a packet end field **48**. This field signals to a receiving device that the transmission is ending. In the embodiment of FIG. 2, the packet end field **48** has eight bits which are all set to a binary "0".

As mentioned above, the signpost signal **24** is typically transmitted in a relatively noisy environment. In order to ensure reliable signal detection, known techniques may be employed to improve the signal to noise ratio (SNR). In the disclosed embodiment of FIG. 1, the amplitude modulation of the 132 KHz carrier is effected using the well-known technique of amplitude shift keying (ASK), in order to improve the SNR. Alternatively, frequency shift keying (FSK) or phase shift keying (PSK) could be used to achieve an even higher SNR. However, FSK or PSK would typically require additional front-end analog circuitry in each tag **12**. Therefore, and since an object of the present invention is to implement both the signpost **11** and the tag **12** at a low cost, ASK is used in the embodiment of FIG. 1.

As noted above, communications between the signpost **11** and the beacon tag **12** are one-way communications involving the signpost signals **24**. With this in mind, it is desirable

to provide a degree of security that ensures the beacon tag **12** will react only to valid signpost signals **24**, especially with respect to the commands in fields **43–45**. Therefore, the fields **42–47** in the word **36** can be subjected to security protection using well-known encryption and/or password techniques.

As discussed above, the signpost **11** in the embodiment of FIG. 1 transmits the signpost signal **24** at a frequency of 132 Kz, in order to provide those signals with an effective range which does not exceed about twelve feet. In some applications, however, there may be a need for a somewhat longer range for the signpost signals. In that case, the signpost signals **24** could be transmitted using a different carrier, for example a high frequency microwave carrier of approximately 2.4 GHz, which would be effective in providing a range of about twenty-five feet. Of course, use of signals at this microwave frequency means that the signpost **11** should generally have a line-of-sight relationship to each tag **12** to which it is transmitting.

Turning to the beacon tag **12**, the tag **12** includes a receiving antenna **61** which receives the signpost signals **24** transmitted by the signpost **11**. The antenna **61** is coupled to a low frequency receiver **62** of a known type, which is designed to receive the signpost signals **24**, extract from them the information shown in word **36** of FIG. 2, and then supply this information to a microcontroller **63** of the tag **12**. The tag **12** also includes a timer **66** which can be used by the microcontroller **63** to measure time intervals that are discussed later. The tag **12** further includes a power source **67**, which is typically a battery. However, in a situation where the tag **12** is stationarily mounted, the power source **67** could alternatively be an AC/DC adapter which is powered by an external source of 120 VAC power, as indicated diagrammatically by a broken line in FIG. 1.

The microcontroller **63** controls an ultra high frequency (UHF) transmitter **68** of a known type, which in turn is coupled to a transmitting antenna **71** of a known type. In the disclosed embodiment, the antenna **71** is omni-directional, but it will be recognized that the antenna **71** could alternatively be configured to be directional. Using the transmitter **68** and the antenna **71**, the microcontroller **63** of the tag **12** can transmit beacon signals **72** to the reader **13**. In the embodiment of FIG. 1, the beacon signals **72** are generated by FSK modulation of certain beacon information onto a carrier signal having a frequency of 433.92 MHz. A suitable alternative frequency is 915 MHz, but the frequency of 433.92 MHz is used in the disclosed embodiment because it is available for use in a wider number of countries than 915 MHz under prevailing governmental regulations for transmission of electromagnetic signals. The transmission range for the beacon signals **72** is substantially longer than that for the signpost signals, and in the disclosed embodiment can be up to about 300 feet. The beacon signals **72** are transmitted using a technique known in the art as a slotted aloha protocol, to reduce interference between beacon signals transmitted by different beacon tags.

In the disclosed embodiment, the beacon information transmitted in the beacon signals **72** may take one of two different forms, both of which are shown in FIG. 3. More specifically, if the beacon tag **12** has received a valid signpost signal **24** through the antenna **61** and the receiver **62**, the beacon information transmitted in the beacon signal **72** will have the word format shown at **81** in FIG. 3. In contrast, during periods of time when the beacon tag **12** is outside the transmission range of the signpost signals **24** from any signpost **11**, the beacon information transmitted in the signal **72** will have the word format shown at **82** in FIG.

3. In the disclosed embodiment, fields **87–88**, **91–92** and **97** (and fields **93** and **96** in the case of the word **81**) are all transmitted using Manchester encoded FSK modulation at 27.7 Kbps.

The word format **81** will be discussed first. It begins with a preamble **86**, which is functionally comparable to the preamble **41** of the word **36** shown in FIG. 2. In the disclosed embodiment, the preamble **86** lasts 1.296 microseconds, and includes 20 cycles which each include a 30 microsecond logic high and a 30 microsecond logic low, followed by one cycle which includes a 42 microsecond logic high and then a 54 microsecond logic low. The next field in the word **81** is a 1-bit format field **87**, which is provided to indicate to a receiving device which of the two formats **81** and **82** in FIG. 3 is the format used for the instant beacon signal. Thus, the field **87** is always a “1” bit in word **81**, and a “0” bit in word **82**.

The next field in the word **81** is a 4-bit tag type field **88**, which is a code that provides some information about how the particular tag **12** is being used in the system. In this regard, the code may indicate that the tag is stationarily mounted, for example on a ceiling, or may indicate that the tag is mounted on some form of mobile device. Further, where the tag is mounted on a mobile device, the tag type code **88** can provide some information about that mobile device, such as whether that mobile device has a standard height, or has a taller, high profile height.

The next field in the word **81** is a 3-bit asset type field **91**. Where the tag **12** is attached to some type of mobile device, the asset type field **91** can identify the specific type of mobile device to which the tag is attached. For example, the field **91** may indicate that the asset is attached to some form of container, to a trailer or dolly on which a container can be transported, or to a tractor capable of pulling trailers having containers thereon.

The next field in the word **81** is a signpost code **93**. This is identically the signpost code extracted at **42** from the signpost word **36** that was most recently received by the beacon tag **12**. In the disclosed embodiment, the word **81** has only one signpost code field **93**. Consequently, a system according to the disclosed embodiment should be configured so that each beacon tag **12** is within the transmission range of only one signpost at any given point in time. However, it will be recognized that additional fields could be provided for additional signpost codes in the word **81**, so that the tag **12** could be within the transmission range of multiple signposts at the same time, while receiving and reporting signpost codes for all of those signposts.

The next field in word **81** is a last command field **96**, which is identically the last command that was received in either of the fields **43** or **44** of the signpost word **36** provided by the signpost having the signpost code which is present in the field **93**. This provides confirmation to the control system **14** that the tag **12** received this particular command from the signpost **11**.

The next field in the word **81** is an error control field **97**. In the disclosed embodiment, this is a 16-bit field containing a cyclic redundancy code (CRC) of a known type, which is calculated using the information in fields **87–88**, **91–93** and **96**. The beacon signals **72** transmitted by the tag **12** to the reader **13** are essentially one-way signals, and the error control field **97** is therefore provided to give the reader **13** a degree of capability to detect and correct some errors in a received word **81**. The reader **13** can also increase accuracy and reliability by receiving and comparing two successive beacon signals **72** and verifying that they are identical.

The last field in the word **81** is a packet end field **98**, which in the disclosed embodiment is a logic low of 36

microseconds. The packet end field **98** indicates to a receiving device that the field **98** is the end of the word **81** which is currently being received.

Turning to the alternative format **82** of the beacon word, the basic difference from the word **81** is that the fields **93** and **96** of the word **81** are omitted from the word **82**. This is because the fields **93** and **96** contain information extracted from the last received signpost word **36**. In contrast, as mentioned above, the beacon word **82** is used in situations where the beacon tag **12** is not currently receiving any signpost signals, and thus has no current information to put into the fields **93** and **96**. Therefore, the fields **93** and **96** are omitted in word format **82**.

In theory, it would be possible to use the word format **81** even when the tag **12** is not currently receiving information from any signpost, and to simply put a “dummy” code such as all zeros into each of the fields **93** and **96**. However, governmental regulations regarding radio transmissions tend to involve a balancing between factors such as the power level at which a beacon signal **72** is transmitted, the time interval between successive transmissions of beacon signals **72**, and the amount of information present in each beacon signal. By using the beacon word format **82** when the fields **93** and **96** are not needed, the duration of the transmission of the beacon signal **72** is reduced, which in turn facilitates compliance with governmental regulations.

There are two other differences between the beacon word format **82** and the beacon word format **81**. First, the field **87** is always a binary “1” in word **81**, and a binary “0” in the word **82**, as discussed above. Second, the CRC value used in error control field **97** is calculated using fields **87–88** and **91–92** in beacon word **82**, because the fields **93** and **96** are not present, and thus cannot be taken into account.

Each transmission of the beacon signal **72** is similar to the transmission of a signpost signal **24**, in that it is a short burst at the carrier frequency which includes one occurrence of either the word **81** or the word **82** (FIG. 3). The beacon tag **12** uses one technique for sequencing the beacon transmissions **72** when the tag **12** is not currently receiving any valid signpost signals **24**, and uses a different technique for sequencing the beacon signals **72** in response to the receipt of a valid signpost signal **24**.

In this regard, during any given time interval, a number of different beacon tags **12** may all be trying to transmit respective different beacon signals **72** to a given reader **13**, and it is inevitable that two or more of these tags will attempt to transmit beacon signals **72** at the same time, such that the signals interfere or “collide” with each other at the reader **13**. The two different techniques used for transmitting the beacon signals **72** each seek to reduce the likelihood that any two tags **12** will transmit beacon signals **72** in a synchronized manner that causes successive beacon transmissions **72** from each of these two tags to repeatedly collide. Consequently, each technique is intended to ensure that, even if two tags each happen to transmit a beacon signal **72** at approximately the same point in time, the next successive beacon signals from these two tags will not occur at the same point in time.

In more detail, and beginning with the situation where the tag **12** is not currently receiving any valid beacon signals **24**, the tag **12** operates in a normal transmission mode in which it divides ongoing time into a succession of time slots having equal lengths, for example 60 second time slots, and in which it effects transmission of one beacon signal **72** within each time slot, at a randomly selected time within that time slot. In the disclosed embodiment, the random selection is actually done with a pseudo-random calculation of a known

type, which closely approximates a truly random determination. References herein to random determinations are intended to include techniques such as pseudo-random determinations.

When the tag **12** receives a valid signpost signal **24**, it immediately interrupts the normal mode of transmission and switches to a special mode of transmission. At the end of the special mode of transmission, it reverts back to the normal mode. The special mode is discussed in association with FIG. 4, in which the horizontal axis at the bottom represents the progression of time from left to right. The vertical line at the left side of FIG. 4 represents the point in time at which a valid signpost signal is received, and represents the point in time at which the tag **12** responds by switching from the normal mode to the special mode. The special mode involves five successive time intervals **111–115**, which are each discussed separately below. After the last time interval **115** of the special mode, the tag **12** reverts from the special mode to the normal mode, where operation in the normal mode is represented by the time interval **116**.

Time interval **111** involves N_1 successive time slots which each have a duration of T_1 . In the disclosed embodiment, N_1 is 5, and T_1 is 0.1 seconds. The tag **12** transmits the beacon signal **22** once during each of these five time slots, at a randomly selected point within that time slot. These five time slots are represented diagrammatically in FIG. 4 by the spaces between the short vertical lines within time interval **111** along the horizontal axis at the bottom of FIG. 4.

It will be noted that the operation of the tag during interval **111** is somewhat similar to the operation of the tag during its normal mode, but there are two basic differences. First, the time slots in the normal mode are each about 600 times longer than the time slots in time interval **111**, and thus the beacon signal **72** is being transmitted an average of 600 times more often than in the normal mode.

Second, during the time interval **111**, the tag **12** transmits each beacon signal **72** at a power level P_1 , which is 24 dB lower than a power level P_2 used during normal operation. As mentioned above, governmental regulation of UHF transmissions can involve a degree of balancing between the duration of each transmission, the time interval between successive transmissions, and the power level of the transmissions. Consequently, since the transmissions in time interval **111** have a longer duration than transmissions in the normal mode (because they involve beacon word **81** of FIG. 3 rather than beacon word **82**), and since they are sent an average of 600 times as often, the reduced power level P_1 is used for these transmissions in order to facilitate compliance with government regulations. The power level which is being used at any given point in time is set forth along the top of FIG. 4.

Time interval **111** is followed by time interval **112**, which is a delay or wait state having a duration T_5 , where T_5 is 1 second in the disclosed embodiment. During the time interval **112**, the tag **12** does not transmit any beacon signals **72**.

Time interval **112** is followed by time interval **113**, which is handled in a manner similar to time interval **111**, except that some parameters are different. In particular, time interval **113** includes N_2 successive time slots which each have a duration of T_2 . In the disclosed embodiment, N_2 is 3, and P_2 is 1 second. A single beacon signal **72** is transmitted during each T_2 time slot, at a randomly-selected time within that time slot. Beacon signals **72** that are transmitted during the time interval **113** are transmitted at the reduced power level P_1 which was used in time interval **111**.

Time interval **113** is followed by time interval **114**, which is a delay or wait state similar to time interval **112**. In

particular, no beacon signals **72** are transmitted, and the time interval has a duration of T_6 , which in the disclosed embodiment is 10 seconds.

Time interval **114** is followed by the time interval **115**, which involves activity similar to the time intervals **111** and **113**. In particular, time interval **115** includes N_3 time slots which each have a duration of T_3 . In the disclosed embodiment, N_3 is 3, and P_3 is 10 seconds. A single beacon signal **72** is transmitted during each of these time slots, at a randomly-selected point within the time slot. In the time interval **115**, the tag **12** reverts to the higher power level of P_2 . In this regard, it will be noted that the average rate of transmission of beacon signals in time interval **115** is about one-tenth of the average rate of transmission of beacon signals in time interval **113**, and is about one one-hundredth of the average rate of transmission in time interval **111**. Thus, and with reference to the above-discussed balancing between the duration of transmissions, the time interval between transmissions, and the power level, the tag **12** can revert to the higher power level P_2 as a result of the significant decrease in the average rate of transmissions, while still complying with government regulations.

Time interval **115** is followed by time interval **116** which, as mentioned above, represents a reversion to the normal mode of operation. In particular, the tag **12** continuously divides ongoing time into successive time slots that each have a duration T_4 , where T_4 is 60 seconds. These beacon signals are each transmitted at the higher power level P_2 , using the shorter format of the beacon word which is shown at **82** in FIG. 3. The time interval **116** does not have a specified duration, and will continue until the tag **12** receives a further valid signpost signal which causes it to again switch to the special mode and carry out the beacon sequence shown in FIG. 4.

The foregoing discussion mentions various parameters, including $N_1–N_3$, $T_1–T_6$, and $P_1–P_2$, and gives specific values for some of these parameters. The specific values given for these parameters are those used in the disclosed embodiment, but it is within the scope of the present invention to vary these parameters.

FIG. 5 is a flowchart showing in a different form the beacon sequence discussed above in association with FIG. 4. In FIG. 5, the microcontroller **63** of the beacon tag **12** enters block **131** in response to receipt of a valid signpost signal **24**. Block **131** corresponds to time interval **111** in FIG. 4. In block **131**, the beacon tag transmits a beacon signal with the power level P_1 at a random time within each of N_1 successive time slots that each have a duration T_1 .

The system then progresses to block **132** in FIG. 5 which corresponds to time interval **112** in FIG. 4. In particular, the beacon tag waits for a time interval T_5 , without transmitting any beacon signals. The system then progresses to block **133**, which corresponds to time interval **113** in FIG. 4. In block **133**, the beacon tag transmits a beacon signal with power level P_1 at a random time within each of N_2 successive time slots that each have a duration T_2 .

The system then progresses to block **134**, which corresponds to time interval **114**. In block **134**, the system waits for a time interval T_6 without transmitting any beacon signals, and then progresses to block **135**. Block **135** corresponds to time interval **115** in FIG. 4. In block **135**, the system transmits a beacon signal with power level P_2 at a random time within each of N_3 successive time slots that each have a duration P_3 .

From block **135**, the system progresses to block **136**, which corresponds to time interval **116** in FIG. 4. The system stays in block **136** indefinitely, until a further valid

11

signpost signal is received. While in block 136, the beacon tag transmits a beacon signal with the power level P2 at a random time within each of a series of successive time slots that each have a duration of T4. If a further valid signpost signal is received, then the beacon tag immediately inter-

rupts its activity in block 136 and returns to block 131, as indicated diagrammatically by the broken line 137, in order to again carry out the beacon sequence which is represented by blocks 131–135.

FIG. 6 is a high-level flowchart depicting the operation of the beacon tag 12. With reference to FIG. 1, the beacon tag 12 has a reduced power mode in which the transmitter 68 is off, the timer 66 is active, the receiver 62 is active, and the microcontroller 63 is in a reduced power or “sleep” mode, from which it can be awakened by either the receiver 62 or expiration of the timer 66. The flowchart of FIG. 6 begins at a point in time when the beacon tag 12 wakes up from the reduced power mode, either because the receiver 62 has received a signpost signal, or because the timer 66 has expired.

The microcontroller 63 of the tag 12 proceeds from block 151 to block 152, where it checks to see if the timer 66 has just expired. If not, then it knows that the receiver 62 has received a signpost signal, and it proceeds to block 153, where it extracts and stores the signpost code (42 in FIG. 2) from the received signpost signal. Then, control proceeds to block 156, where the beacon tag checks to see whether the received signpost signal also includes a command in either of fields 43 and 44 (FIG. 2). If so, then the tag proceeds to block 157, where it executes the command. Then the tag proceeds to block 158, where it returns to its reduced power “sleep” mode.

Looking again at block 156, if the beacon tag were to determine that the signpost signal did not include a command, then the beacon tag would have proceeded to block 161, where it resets the beacon sequence. This corresponds to the broken line 137 in FIG. 5, where the tag leaves the normal mode of operation represented by block 136, and returns to block 131 in order to carry out the special beacon sequence which is represented by blocks 131–135 in FIG. 5 and by time intervals 111–115 in FIG. 4.

Then, at block 162, the beacon tag determines the next point in time at which it needs to transmit its beacon signal according to the beacon sequence. Since the beacon sequence has just been restarted in block 161, this will be a determination of the point in time to transmit the beacon signal within the first time slot of the time interval 111 in FIG. 4. As discussed above, this will involve a random determination of a point in time within the time slot, for example using a pseudo-random technique of a known type. Once this point in time has been selected, the beacon tag 12 sets the timer 66 (FIG. 1) in block 163 of FIG. 6, so that the timer will expire at the proper point in time to allow transmission of the next beacon signal, and then the beacon tag 12 returns to the sleep mode at block 158.

Returning to block 152 in FIG. 6, if it had been determined that the microcontroller 63 was awakened from the sleep mode because the timer 66 expired, the microcontroller 63 would have proceeded from block 152 to block 167. In block 167, a determination is made of whether the timer expired because it is time to transmit the next beacon signal. If not, then the beacon tag proceeds directly to block 158, where it returns to the sleep mode. Otherwise, it proceeds from block 167 to 168, where it effects transmission of its beacon signal 72 (FIG. 1) It then proceeds to block 162, where it picks the transmit time for its next successive beacon signal. Then, at block 163, it sets the timer to expire

12

at the point in time that it determined. Then, at block 158, it returns to the reduced power sleep mode.

At an earlier point in this discussion, in association with the discussion of FIG. 2, it was indicated that the command fields 43–45 would be described in due course. The following is a discussion of those fields.

The tag command field 43 is a 2-bit field which can be used to instruct a beacon tag 12 (1) to turn itself off (which is actually a low power sleep mode in which no beacon signals are transmitted), (2) to turn itself on (which is a mode in which beacon signals are transmitted in the manner described above in association with FIGS. 4–6), (3) to operate at a fast beacon rate, or (4) to operate at a slow beacon rate (where the slow rate uses a duration for each time slot T4 of FIG. 4 that is longer than the duration used for the fast rate).

Turning to the control command field 44 and the parameter field 45, it was mentioned above that the parameter field 45 contains a parameter needed to implement a command specified by the control command field 44. One command which can be specified in the control command field 44 is an instruction to the beacon tag 12 to set the beacon code that it puts into field 92 (FIG. 3), and in that case the parameter field 45 would contain the new beacon code. Another command which can be specified by the control command field 44 is an instruction to the beacon tag 12 to set a password or an encryption key used for security, as discussed above, and the parameter field 45 would contain the new password or encryption key. Yet another command which can be specified by the control command field 44 is an instruction to the beacon tag 12 to set the tag type code that it puts into field 88 (FIG. 3), or the asset type code that it puts into field 91, and the parameter field 45 would contain the new tag type code or asset type code. Still other commands in the control command field 44 could instruct the beacon tag to change any one of the various parameters discussed above in association with FIGS. 4 and 5, including P1, P2, N1, N2, N3, T1, T2, T3, T4, T5, and T6, and the parameter field 45 would contain the new value for the specified parameter. It will be recognized that there are still other commands which could be sent to the tag 12 using the control command field 44 and, where needed, the parameter field 45.

Referring again to FIG. 1, the reader 13 will now be described in greater detail. The reader 13 includes two antennas 211 and 212 which are of a known type, and which are each suitable for receiving UHF wireless signals. The reader 13 also includes two UHF receivers 213 and 214, which each have an input coupled to a respective one of the antennas 211 and 212. The reason that the reader 13 has two UHF antennas 211–212 and two UHF receivers 213–214 is that the antennas 211–212 are arranged to extend perpendicular to each other. The reader 13 is capable of determining which of the two antennas 211–212 is producing the strongest output in response to a given beacon signal 72. The reader 13 then selects the stronger output for use as the received version of that particular beacon signal.

The reader 13 also includes a decoder 217 of a known type, which has two inputs that are each coupled to an output of a respective one of the receivers 213–214. The decoder 217 processes the signals received by each of the receivers 213–214, in order to extract usable information therefrom, which can then be passed to a microcontroller 221 of the reader 13. A real time clock (RTC) circuit 222 is coupled to the microcontroller 221. Further, the reader 13 includes a network interface 223. A network 226 is of a type known in the industry as an Ethernet network, and couples the network

interface **223** of the reader **13** to the control system **14**, in order to facilitate communication between the reader **13** and the control system **14**. The basic function of the reader **13** is to receive beacon signals **72** from various beacon tags (such as the tag **12**), verify that each received beacon signal is valid, perform error detection and correction where needed, extract information such as one or more of the fields shown at **87–88**, **91–93** and **96** in FIG. **3**, and then pass this extracted information on to the control system **14**.

FIG. **7** is a diagrammatic top view of a system **240** which represents one practical application of an apparatus of the type shown at **10** in FIG. **1**. The system **240** of FIG. **7** includes a plurality of signposts, sixteen of which are shown at **241–256** in FIG. **7**. Each of the signposts **241–256** is identical to the signpost shown at **11** in FIG. **1**, except that they each use a respective unique signpost code **42** (FIG. **2**). The signposts **241–256** have been given different reference numerals in FIG. **7** in order to facilitate a discussion of how the system **240** operates.

The signposts **241–256** are each stationarily mounted, for example on the ceiling of a warehouse or other industrial facility. The sixteen signposts **241–256** are arranged in a regular 4×4 array. The broken line circle which extends around each signpost in FIG. **7** is a diagrammatic representation of the effective outer limit of the transmission range of the signpost signals emitted by that signpost. As discussed above, each signpost has a limited transmission range of only about 12 feet or less, and the spacing between the signposts **241–256** has thus been intentionally selected so that no two signposts have overlapping transmission ranges. Although sixteen signposts **241–256** are shown in FIG. **7**, this 4×4 array is just a portion of a much larger array that covers a much larger area. However, the array shown in FIG. **7** is sufficient for purposes of explaining certain principles of the present invention.

A reader **261** is stationarily mounted within the array of signposts **241–256**, for example on the same ceiling that supports the signposts. The reader **261** is identical to the reader shown at **13** in FIG. **1**, but is given a separate reference numeral here for clarity. The system **240** would actually include a number of other equivalent readers at spaced locations, but only one reader **261** is illustrated in FIG. **7** in order to facilitate a clear explanation of certain features of the invention.

Five beacon tags **271–275** are also depicted in FIG. **7**. The beacon tags **271–275** are each effectively identical to the beacon tag shown at **12** in FIG. **1**, but have been given separate reference numerals for clarity in the discussion which follows. For purposes of the following explanation, it is assumed that the beacon tags **271–275** are each mounted on a different mobile device, such as a container, a pallet, a forklift, a trailer which can support a container, a tractor which can pull a trailer, or some other type of mobile device.

Focusing first on the beacon tag **271**, it will be noted from FIG. **7** that this tag is currently within the transmission range of the signpost **241**. Consequently, the beacon tag **271** will be receiving signpost signals **281** from the signpost **241**, and will be transmitting beacon signals **282** to the reader **261**. The beacon signals **282** will include the beacon code unique to the beacon tag **271**, as well as the signpost code unique to the signpost **241**. Consequently, since this signpost code and this beacon code are received in combination with each other in the beacon signal **282**, the control system associated with the reader **261** can determine that the beacon tag **271** is presently within the transmission range of the signpost **241**. This in turn means that the mobile device which carries the beacon tag **271** is currently very close to the signpost **241**.

Since the control system knows the physical location of the signpost **241**, the system can make a relatively accurate determination of the current location of the mobile device which carries the beacon tag **271**, localized to the transmission range of the signpost **241**. In particular, the system can determine the current location of the beacon tag **271** and its associated mobile device to an accuracy of about 12 feet, which is the radius of the transmission range of the signpost **241**. It will be recognized that this capability is due in part to the fact that the signpost signals have a relatively local transmission range, whereas the beacon signals have a transmission range which is about 30 times farther than the transmission range of the signpost signals.

For purposes of comparison, assume for a moment that the signposts **241–256** were all omitted from the system **240** of FIG. **7**. In that case, the beacon signals **282** from the beacon tag **271** would each include the unique beacon code of the tag **271**, but would not include any signpost code. By analyzing the strength of the beacon signal **282**, as received at the reader **261**, the control system associated with the reader **261** could make a very rough estimate of the distance between the tag **271** and reader **261**. However, it would be difficult for the control system to accurately determine which direction the beacon signal **282** came from. In this regard, even though the reader **261** has two orthogonal antennas (equivalent to those shown at **311–312** in FIG. **1**), the reader **261** would not know whether the beacon signal **282** arrived from one direction, or from a diametrically opposite direction.

Still assuming that no signposts are present in the system, but that a second reader is provided in a manner so that both readers receive the beacon signals **282**, the control system could estimate the distances from the beacon tag **271** to each of the two readers. With this information, it would be possible to carry out a standard triangulation calculation in order to attempt to estimate the location of the beacon tag **271**. But due to rather wide tolerances in the ability to estimate distances from the beacon tag to each reader based on beacon signal strength, even triangulation produces only a very coarse estimate of location, which is not particularly accurate and reliable. It will thus be recognized that, through use of the signposts **241–256** in FIG. **7**, a significantly more accurate and reliable determination can be made of the current location of the beacon tag **271**.

In FIG. **7**, the mobile device associated with the beacon tag **275** is currently in a location where the beacon tag **275** is not within the transmission range of any of the signposts **241–256**. Thus, the reader **261** is receiving a beacon signal from the beacon tag **275**, but the beacon signal includes only the beacon code of the tag **275**, and does not include a signpost code from any of the signposts **241–256**. Therefore, the tag **275** is temporarily situated where the system cannot determine its location as accurately as if it were currently within the transmission range of any of the signposts. Nevertheless, the system **240** may still have a relatively accurate idea of the current location of the tag **275**, by tracking it over time.

For example, the system may know that the tag **275** reached its current location by moving through the transmission range of signpost **243** and then through the transmission range of signpost **242**, and the system may thus predict that the tag **275** will soon enter the transmission range of signpost **245**. Therefore, even though tag **275** is not currently within the transmission range of any signpost, the system still has a better idea of the current location of the tag **275** than would be the case if there were no signposts at all.

A further consideration in this regard is that, within a warehouse or other industrial facility, there are often defined paths that mobile devices tend to follow through the facility. Accordingly, the system may be well aware that there is a defined path which extends successively past signpost **243**, signpost **242**, and signpost **245**. This will provide the system with an even better ability to accurately estimate the current location of tag **275**, even when it is not currently within the transmission range of any of the signposts **251–256**.

It is possible for two or more beacon tags to be simultaneously within the transmission range of a single signpost, such that all of those beacon tags are simultaneously receiving the same signpost signal emitted by that signpost. This is the case with beacon tags **272–274** in FIG. **7**, which are all within the transmission range of the signpost **248**. The reader **261** receives a separate beacon signal from each of the tags **271–274**, and each of these beacon signals includes the unique beacon code of the corresponding beacon tag, in combination with the signpost code of the signpost **248**. Thus, the control system associated with reader **261** can distinguish the beacon tags **272–274** from each other, due to their unique beacon codes, and can also determine that all of these beacon tags are currently at locations within the transmission range of the signpost **248**.

Although FIG. **7** shows an array of signposts **241–256** which are stationary, and several beacon tags **271–275** which are mobile, the stationary and mobile characteristics of the signposts and beacon tags can be reversed. In this regard, FIG. **8** is a diagrammatic top view of a system **300** which has sixteen stationary beacon tags **301–316**, each of which is equivalent to the beacon tag **12** of FIG. **1**. These beacon tags are arranged in a 4×4 array, with spacing equivalent to that used for the signposts **241–256** in FIG. **7**. A reader **319** is provided at a central location within the array, and is also stationary. A signpost **322** is mounted on a mobile device, which can move within the facility, and thus can move with respect to the stationary beacon tags **301–316**. At the point in time depicted in FIG. **8**, the mobile device carrying signpost **322** is at a location near the beacon tag **301**, such that the beacon tag **301** is within the transmission range of the signpost **322**.

The signpost **322** is transmitting a signpost signal, but the only beacon tag which can currently receive that signal is the beacon tag **301**. Thus, the beacon tags **301–316** are each transmitting a respective beacon signal to the reader **319**, and each of these beacon signals includes a unique beacon code, but only the beacon signal from the tag **301** also includes the unique signpost code that it is receiving in the signpost signal from the signpost **322**. The control system associated with the reader **319** will know the physical location of each of the stationary beacon tags **301–316**. Thus, the location of the mobile device associated with the signpost **322** can be determined with the same degree of accuracy achieved in the system of FIG. **7**, because the control system for the embodiment of FIG. **8** knows that the distance between the signpost **322** and the beacon tag **301** must be less than the radius of transmission of the signpost signals from signpost **322**, or in other words approximately 12 feet. If the signpost **322** moves until it is close to the beacon tag **302**, then the beacon tag **301** will no longer be within the transmission range of the signpost signals from signpost **322**, but the beacon tag **302** will be within that transmission range. Consequently, the beacon tag **301** will stop transmitting the signpost code from signpost **322** in its beacon signal, and the beacon tag **302** will start transmitting this signpost code in its beacon signal. As a result, the control system associated with reader **19** can track the movement of the mobile device associated with signpost **322**.

One difference between the systems of FIGS. **7** and **8** is that, since the beacon signal from any beacon tag is configured to include only one signpost code, each beacon tag should never be within the transmission range of more than one signpost at any given point in time. In the system of FIG. **7**, this is assured by the stationary mounting of the signposts **241–256**, with appropriate spacing provided between them. In contrast, since the signposts can move in the system of FIG. **8**, care must be taken to ensure that two or more signposts do not come into proximity with the same beacon tag at the same point in time. This is not to suggest that the approach of FIG. **7** is more advantageous than the approach of FIG. **8**. One of these approaches may be better for some applications, and the other may be better for other applications. In fact, it should be evident from the discussion which follows that, in some applications, it would be possible to use a combination of the two approaches.

Certain additional aspects of the present invention will be discussed below. It is believed that these additional aspects will be more clearly understood if presented in the context of an example of a specific application. Therefore, the discussion which follows will focus on a private company which is in the business of overnight package delivery. As is well known, companies of this type provide a service in which they pick up a package from a sender on one day, and then deliver it to a recipient on the following day, typically before noon. The sender may be in one city, such as Boston, and the recipient may be a different city, such as Tucson.

On the day that a package is picked up in Boston, the company will also typically pick up a number of other packages in Boston, which will be going to a variety of other cities throughout the country. The following day, the company will have a number of packages to deliver in Tucson, which were picked up the preceding day in a number of different cities across the country. In order to efficiently handle the routing of all these packages, existing companies typically provide some form of hub facility at a major airport. During the night, a container will arrive from a city such as Boston, containing a number of packages that need to be delivered in many different cities. The container will be unloaded at the hub facility, and then the packages will be sorted, in order to group the sorted packages by destination city. Thus, for example as to Tucson, the sorting process will yield a group of packages destined for delivery in Tucson, which arrived at the hub facility in a variety of different containers from a variety of different cities of origin. The group of packages destined for Tucson will be packed into a container, and that container will be transported to Tucson, where the packages will be delivered locally.

With respect to a hub facility of the type discussed above, the majority of containers will typically arrive in one of two different ways. First, containers from cities that are not too far from the hub facility will typically arrive by highway, in various types of trucks. These trucks are commonly referred to as feeders. The containers from more remote cities will typically arrive by airplane. The shapes and sizes of the containers which arrive by airplane and by truck can vary widely. FIG. **9** is a diagrammatic perspective view of one type of container **381** which is particularly suitable for use in airplanes, because it has a shape which facilitates packing of a number of such containers into the somewhat rounded shape of an airplane body.

The container **381** of FIG. **9** has an approximately square bottom wall **382**, and a top wall defined by a horizontal central portion **383**, and two angled portions which extend downwardly at an incline from opposite sides of the portion **383**, one of the angled portions being visible at **384**. The

container **381** has four side walls which each extend vertically upwardly from an edge of the bottom wall to an edge of the top wall, and two of these side walls are visible at **387** and **388** in FIG. **9**. The container **381** also has two doors **391** and **392**, which can each pivot between an open position and a closed position. A not-illustrated latch is provided for securing the doors **391–392** in a closed position, and is configured in a known manner to permit the doors to be locked or sealed in their closed positions, so that packages cannot be removed by unauthorized individuals as the containers are being transported to or from the hub facility.

The container **381** is itself a known device. According to the invention, three beacon tags **395–397** are fixedly secured to the container **381** at spaced locations thereon. Each of the tags **395–397** is equivalent to the tag **12** of FIG. **1**. The tag **395** is provided on the central portion **383** of the top wall of the container. The tags **396** and **397** are provided on respective opposite sidewalls of the container **381**, closely adjacent diagonally opposite corners of the bottom wall **382**. The various types of containers which travel to and from the hub facility by truck and plane can each be referred to as a unit load device (ULD). The container **381** of FIG. **9** is one example of a ULD.

FIG. **10** is a diagrammatic top view of an installation **400** which includes a hub facility **401** of the type discussed above. In the hub facility **401**, packages being transported by an overnight delivery service are received from many cities of origin, unpacked, sorted, repacked, and then transmitted to many destination cities. That is, the hub facility **401** in FIG. **10** is essentially a building where packages are unloaded from containers, sorted, and then reloaded into other containers. The overall installation **400** includes an inbound section **403** and an outbound section **404**, which are both external to the physical building of the hub facility **401**. The inbound section **403** relates to receipt and initial processing of incoming containers, and the outbound section **404** deals with the processing of outgoing containers.

A tracking system of the general type discussed above in association with FIG. **7** is used for the installation **400**, but for clarity is not shown in FIG. **10**. This tracking system includes a plurality of spaced signposts mounted on the ceiling of the hub facility **401**, and at selected other locations throughout the installation **400**, as discussed below. Further, a plurality of readers are provided throughout the installation **400**. In the hub facility **401**, the readers are mounted on the ceiling. In the inbound and outbound sections, there are readers mounted at entrance and exit gates, on or near unloading equipment, on light poles, on buildings, on fences, on special supports, or on other suitable structure which may be present. In general, the signposts are provided in areas where very accurate estimates of tag location are needed, using techniques of the type discussed above in association with FIG. **7**. In contrast, in areas where a coarser estimate of tag location is sufficient, signposts can be omitted so that beacon signals do not include signpost codes, and estimates of location can be based on the strength of beacon signals as received at the readers.

Turning in more detail to the flow of materials through the installation **400**, an arriving airplane taxis to the inbound section **403**, where it is parked at **411**. The airplane may be parked at one of two different types of locations. One is commonly referred to as an “on wing” location. This means that the aircraft is parked closely adjacent a building, which typically has a built-in loader or unloader that can be extended to a door of the plane in order to facilitate loading and unloading. The other type of location is known as an “on ramp” location. This means that the airplane is parked on the

tarmac at a location spaced from any building. Loading and unloading of such a plane are carried out using known types of mobile loaders and unloaders that can travel out to the airplane and then back to a building.

It is a governmental requirement that most electronic devices which are traveling on airplanes must be disabled during the flight, so that they do not produce any type of wireless electromagnetic signal which might interfere with the operation of the plane. Thus, to the extent that any signpost or beacon tags of the type shown at **11–12** in FIG. **1** are traveling by airplane, they must be turned off during the flight, or at least must be in an operational mode where they do not transmit electromagnetic signals. As discussed above, beacon tags **395–397** are provided on ULDs of the type shown at **381** in FIG. **9**. Consequently, when these ULDs are unloaded from an airplane, the beacon tags need to be turned on. As discussed above, the tag command field **43** (FIG. **2**) of a signpost signal can turn a beacon tag on or off. Consequently, stationary signposts can be provided on or near each unloading device, or in the region of the airplane unloading operation, in order to turn on all of the beacon tags which are present on the ULDs that are being unloaded. Alternatively, a handheld signpost could be manually used by an operator to turn on all of the beacon tags which are on the equipment being unloaded. The beacon tags on the unloaded ULDs thus begin transmitting their beacon signals.

As noted above, the inbound section **403** has a plurality of readers of the type shown at **13** in FIG. **1**, at appropriately selected locations throughout the inbound section **403**. These readers are provided on or near the airplane unloading equipment, on light poles, on buildings, on fences, on special supports, or on other structure. The beacon signals generated by the tags on each ULD will be received by one or more of these readers, which each will forward the received information to a central control system of the type shown at **14** in FIG. **1**. Since the control system knows which beacon tags are mounted on which ULDs, the control system can determine which ULDs have arrived by airplane. The control system can then begin planning how to route each ULD through the installation **400**.

In this regard, there are occasional situations in which a ULD comes from an origin city which has so many packages going to a single destination city that all of these packages have been packed into a single ULD. In that case, the control system can arrange for the ULD to be transferred directly from the inbound section **403** to the outbound section **404**, because there is no need to do any unpacking, sorting or repacking. However, the vast majority of ULDs will need to be unpacked and sorted, and thus will need to be routed to the hub facility **401**.

As to all arriving ULDs, the control system will have electronically received from each origin city an identification of the ULDs being sent, and a list of the specific packages in each such ULD. Thus, depending on the departure schedules for planes traveling to destination cities, the control system can prioritize the order of handling arriving ULDs, so that the ULDs containing packages that need to be on the earliest departing flights can be handled before ULDs which do not contain packages that need to be on the earliest departing flights. Based on the electronic information received from origin cities, the control system knows which ULDs should be on each arriving plane, and can determine whether one of the expected ULDs is missing, or whether an extra and unexpected ULD is present. The arrival time of each ULD can also be recorded.

When the plane is parked on ramp, ULDs can be transported to the hub facility using a train which includes several

releasably coupled trailers or “dollies”, and a tractor or tug which can pull the trailers. Each ULD can be transferred to a respective trailer of the train. A train of this type is described in more detail later. In FIG. 10, block 142 reflects this transfer of ULDs onto trailers. The train then transports the ULDs to the hub facility 401. In contrast, if the plane is parked on wing, the ULDs may or may not be transferred to a train of this type. They may instead be transported by conveyor, by a device such as a cart which can be manually pushed, or by some other transport apparatus. Block 413 in FIG. 10 represents the transfer of ULDs from the plane to some form of appropriate device that will facilitate transport of the ULDs.

At block 416 in 403, each arriving ULD is manually checked against the manifest for the arriving flight. Then, at block 417, the ULDs destined for the hub facility are moved to the hub facility. As mentioned above, readers are provided at selected locations throughout the installation 400, including the inbound section 403, the hub facility 401, and the outbound section 404. Further, signposts of the type shown at 11 in FIG. 1 are provided at a variety of selected locations throughout the installation 400, especially at locations which the ULDs must travel past as they are routed through the installation 400. Thus, for example, signposts are provided along typical paths of travel, at doorways, and at various stations where ULDs can temporarily wait for attention, which are referred to as “staging” areas. Using the basic approach discussed above in association with FIG. 7, the control system can accurately track each ULD throughout the entire installation 400.

The ULDs from the staging area 418 are each eventually transported to one of several unloading stations 421. At each unloading station, an operator opens the ULD, and also presses a push button on an adjacent control panel, in order to indicate to the control system that the unloading process has started. The operator then unloads all of the packages from the ULD, by placing them on conveyors which carry them to a package sort section 422. When the operator finishes unloading a ULD, the operator presses a further button on the control panel, to indicate to the control system that the manual unloading process has been completed. In the disclosed embodiment, the control panel at each unloading station is a physical part of the unloading station. However, it can alternatively be provided in the form of a portable wireless device carried by the operator. The empty ULDs are each taken to a staging area 426, and are eventually moved to a staging area 427, either directly or through a further staging area 428, which is outside the physical building of the hub facility 401.

Referring again to the inbound section 403, and as discussed above, packages can arrive not only by airplane, but also by truck. As noted above, the trucks are referred to as feeders. The feeders can contain ULDs, in which case the ULDs can be unloaded and handled in a manner very similar to that discussed above in association with an arriving airplane which is parked on ramp. More typically, however, the feeders include packages which are not packed in ULDs. In that case, the feeder itself is treated as the container for the packages, and the lower portion of FIG. 10 addresses how this type of feeder is handled.

In particular, at block 436 the feeder is checked in at the gate of the inbound section 403. A temporary beacon tag similar to that shown at 12 in FIG. 1 is attached to the feeder, for example using some special mounting bracket. At the same time, the person attending the gate makes an entry in a computer, which advises the central control system of the arrival of the feeder, and also advises the control system of

the particular beacon tag which has been attached to that feeder, in order to permit the control system to associate the electronic manifest for that feeder with the actual physical feeder as it moves through the installation 400.

If the feeder is a truck in the form of a cab pulling a trailer, commonly known as a tractor-trailer combination, the trailer may be separated from the cab and moved through the installation 400 using small local tractors of a type commonly referred to as yardbirds. On the other hand, if the cab is an integral part of the feeder, the entire track may move through the installation 400.

In any event, at block 437 the feeder is moved from the inbound section 403 to a staging area 441 that is adjacent to but outside of the building that serves as the hub facility 401. The control system schedules these feeders for movement to feeder unloading stations, one of which is shown at 442. Each feeder is unloaded, in a manner similar to that described above for the ULD unloading stations 421. The packages removed from the feeders travel to the package sort section 422, for example by conveyor, while the empty feeders are routed to an empty feeder staging area 443.

In the package sort section 422, all packages that are intended for a given destination city are routed to a selected one of several loading stations 451. An empty ULD is taken from the staging area 427, and is loaded with packages headed for that destination city, either until the ULD is full or until it contains all of the packages bound for that destination city. Then, that ULD is transferred to a ULD weigh scale section 452, where each ULD is weighed. The weigh scale 452 is coupled to the central control system, so that the control system will know the weight of each loaded ULD, and thus can carry out appropriate planning with respect to how much total weight is being loaded on each departing airplane.

After each ULD has been weighed at 452, it is moved to an outbound staging area 453. From there, it is in due course moved out of the building through a door having a signpost nearby, and the control system is notified of its exit from the hub facility 401 by virtue of beacon signals which are from a tag on the ULD and which include the signpost code of the signpost. Then, as represented diagrammatically by blocks 456, 457 and 458, these ULDs are transported by trains of the type discussed earlier to the outbound section 404, where each is loaded on an airplane traveling to the destination city for all of the packages within that ULD.

As mentioned above, government regulations prohibit devices such as beacon tags from emitting wireless electromagnetic signals during airplane flight. Accordingly, as each ULD is loaded on a plane, all of the beacon tags associated with it are turned off, or at least placed into a mode in which they do not emit any beacon signals. This can be effected using a stationary signpost in the region of the loader for the airplane, or using some form of portable signpost operated by a person involved with the loading process. As noted above, one of the commands which can be present in the tag command field 43 (FIG. 2) of a signpost signal is a command which turns off any beacon tag that receives the signal. When an airplane has been loaded with all of the ULDs it is scheduled to carry, the airplane taxis out of the outbound section 404, and then takes off for its destination city.

Some of the packages sorted in the sort section 422 are scheduled to depart by truck rather than airplane, for example where they are to be delivered to destinations that are not far from the installation 400. The sorting process routes these packages to feeder load stations, one of which is shown at 461. An empty feeder from the feeder staging area 443 is moved to one of the feeder load stations 461,

where it is loaded with sorted packages that it is carry to one or more relatively local delivery centers. The loaded feeder is then moved from the hub facility **401** to the outbound section **404**, where the temporary beacon tag on that feeder is removed, and an appropriate entry is made in a terminal coupled to the control system. The feeder then leaves the outbound section **404**. In this regard, if the feeder is a trailer being moved by a yardbird, it is detached from the yardbird and coupled to an available cab, and the cab then pulls it to its destination.

As mentioned above, the system which tracks ULDs and feeders through the installation **400** is not shown in FIG. **10**. This system is referred to as a ULD Tracking System (UTS), and FIG. **11** is a diagrammatic view of selected portions of this UTS system, which is designated generally in FIG. **11** with reference numeral **500**. In more detail, the UTS system **500** includes a UTS server **502**, the hardware of which is a suitable computer system of a commercially available type. The server **502** is associated with a database **503**, which may be stored on a hard disk of the server **502** itself, or in some type of physically separate storage device that is operatively coupled to the server **502**. The system **500**, including the server **502**, is fault tolerant in the disclosed embodiment, including the provision of a degree of redundancy, in order to permit the system to automatically reconfigure itself in a known manner so as to work around localized faults that may occur. In this regard, it will be recognized that, since all of the packages being handled in the installation **400** absolutely have to be delivered the following day, it is simply unacceptable for a failure within the system **500** to bring the operation of the installation **400** to a halt. The techniques used to obtain fault tolerant capability are of a known type, and are therefore not disclosed here in detail.

The server **502** is interfaced at **504** to several other systems, which technically are not part of the UTS system **500** itself, and they are therefore shown in broken lines in FIG. **11**. One is the ULD weigh scale section **452**, which was mentioned above in association with FIG. **10**. Another is an air hub control system (AHCS) **506**, which is a separate computer system that provides overall control for the installation **400** of FIG. **10**, including functions other than tracking of feeders and ULDs within the installation **400**. The server **502** is also coupled to a weigh and balance system **507**, and an operation planning and control (OPC) system **508**. The server **502** could also be optionally coupled to some other type of computer system **509** used at the facility **400**.

Turning in more detail to the UTS system **500**, and as mentioned above, there are a plurality of readers which are each equivalent to the reader shown at **13** in FIG. **1**. Ten of these readers are shown at **521–530** in FIG. **11**, but this is merely a representative sample of the total number of readers provided throughout the entire installation **400**. Six readers **521–526** from this group are each coupled to the server **502** through wires of a network **536**. In the disclosed embodiment, the network **536** is of a type commonly known in the art as an Ethernet network. Two reader controllers **537–538** are also coupled to the network, to facilitate communications between the server **502** and the readers. The structure and operation of the reader controllers **537–538** are known to those skilled in the art, and therefore not described here in detail.

The remaining readers **527–530** in FIG. **11** are not coupled directly to the network **536**. Instead, each is coupled to a respective wireless receiver/transmitter **541–544**, each of which communicates through wireless signals with a respective one of two additional wireless receiver transmit-

ters **547–548**, which serve as access points to the network **536**. These wireless links conform to a known standard which was propagated by the Institute of Electrical and Electronic Engineers, and which is commonly known as the IEEE 802.11 standard. Since persons skilled in the art are already familiar with this standard, a detailed discussion of it is unnecessary here.

The readers **521–526** which are coupled directly to wires of the network **536** are likely to be readers provided within the physical building of the hub facility **401**, whereas the readers **527–530** which are coupled to the network **536** by wireless links **541–544** and **547–548** are more likely to be the readers which are in the inbound section **403** and the outbound section **404**. This is because the additional expense of the wireless equipment is more likely to be cost effective in exterior locations, where some significant cost would be involved in running wires to isolated locations. However, the present invention does not preclude the use of wireless links within the building of the hub facility **401**, or the use of direct network connections at locations outside the hub facility **401**.

In FIG. **11**, a choke point reader system **549** is coupled to the network **536**. It can cooperate with at least some of the readers **521–530**, in order to provide an immediate and accurate log of the specific time and location when a beacon tag passed a certain spot referred to as a “choke point”. A choke point is a location which many or all of the beacon tags must pass, one example being a doorway through which all ULDs must pass in order to enter the hub facility **401**. The reader system **549** ensures that an accurate log of the time and location is immediately recorded, because the server **502** will sometimes be too busy with other tasks to respond sufficiently quickly to accurately record the time and location. To the extent that the choke point reader system **549** collects information, it passes the information on to the server **502** in due course.

Server **502** is also coupled through a further network **561** and two network controllers **562–563** to several wireless base stations, four of which are shown at **566–569**. Base stations of the type shown at **566–569** are provided throughout the installation **400**, and permit the server **502** to communicate in a wireless manner with several wireless handheld devices **571–578**. The handheld devices **571–578** each include a keypad and a display, and are used for various purposes.

One such purpose is to permit persons throughout the facility to obtain information about a ULD, a mobile device or some other item associated with a given tag. The control system **14** maintains information in an electronic form about the items associated with each tag, and can thus easily provide pertinent portions of this information on request to any of the handheld devices **571–578**. Similarly, the control system could be configured to provide this information through the Internet to a standard “web browser” program. Another purpose of the handheld devices **571–578** is to permit the server **502** to issue instructions to persons who are working within the installation **400**. For example, a person operating a mobile device such as a forklift transporting a ULD may need to be given instructions regarding what he or she should do with the ULD. In this regard, if the ULD is to be taken to one of the unloading stations **421** (FIG. **10**), the operator needs to know which specific unloading station the ULD should be delivered to. Similarly, if a ULD is waiting in a staging area, and the operator is to pick it up, the operator needs to know which specific ULD to pick up. The server **502** can convey this information to the operator through one of the handheld devices **571–578** carried by that operator.

The handheld devices **571–578** also have the capability to function as beacon tag readers. This permits an operator, with or without help from the server **502**, to identify whether a particular ULD near the operator is a ULD which the system wants the operator to do something with.

The handheld units **571–578** can also be used by an operator to notify the server **502** of equipment which the operator is currently using. For example, if the operator takes control of a yardbird in order to move feeders around the installation **400**, identification codes for the operator and the yardbird can be entered manually on the keypad, or can be scanned in an appropriate manner such as by scanning bar codes on the yardbird and on the operator's badge with a bar code scanner in the handheld device, so that server **502** knows which equipment that particular operator is currently using. The server **502** can then use that handheld device to give the operator specific instructions regarding what the operator should do with that piece of equipment.

FIG. **12** is a diagrammatic view of a train **600**, which is of a type that has been mentioned above, and which can be used to transport ULDs within the installation **400** of FIG. **10**. The train **600** of FIG. **12** includes a tractor or tug **601** which pulls the train, and three trailers or dollies **602–604**. The tractor **601** and trailers **602–604** are each a type of mobile device.

The trailers **602–604** are all identical. The trailer **602** has at its forward end a tongue, which is releasably coupled to a hitch at the rear of the tractor **601**. The trailer **603** has at its forward end a tongue which is releasably coupled to a hitch at the rear of the trailer **602**, and the trailer **604** has at its forward end a tongue which is releasably coupled to a hitch at the rear of the trailer **603**. Although the train **600** of FIG. **12** has three trailers, it will be recognized that the number of trailers could be larger or smaller. Each of the trailers **602–604** has a respective ULD **606–608** removably supported thereon. The ULDs **606–608** are each identical to the ULD **381** discussed above in association with FIG. **9**.

The tractor **601** has thereon a beacon tag **611**, which is provided at the top of a post in order to elevate the beacon tag **611** so that is relatively close to the signposts provided on the ceiling, one of which is shown at **612** on a ceiling shown diagrammatically as a broken line **613**. The broken line circle around the signpost **612** represents the transmission range of the signpost **612**. It should be noted that the transmission range of the signpost **612** is specifically configured so that the trailers **602–604** will pass below the lower portion of the transmission range of the signpost **612**. Three beacon tags **616–618** are each provided on top of a respective one of the ULDs **606–608**.

As the tractor **601** moves through the installation **400**, the beacon tag **611** thereon will move into and out of the transmission ranges of various signposts throughout the facility, thereby permitting the location of the tractor **601** to be accurately tracked in the manner described above in association with FIG. **7**. The beacon tags **616–618** provided on top of the respective ULDs **606–608** will also pass through the transmission ranges of various signposts, thereby facilitating direct and accurate tracking of the location of each of the ULDs **606–608**.

The tractor **601** has a signpost **623** located near the hitch on its rear. The trailers **602–603** each have a respective signpost **626–628** on a right rear corner thereof. The trailers **602–604** also each have a respective beacon tag **631–633** supported on the tongue thereof. As discussed above, the signposts on the ceiling, such as the signpost **612**, each have a transmission range which ends at a height vertically above the trailers. Thus, the beacon tags **631–633** on the tongues of

the trailers do not pass through the transmission ranges of the signposts on the ceiling.

The beacon tag **631** on the tongue of the trailer **602** is within the transmission range of the signpost **623** on the rear of the tractor **601**, but is outside the transmission range of the signpost **626** disposed on the same trailer **602**, because the beacon tag **631** and the signpost **626** are near opposite ends of the trailer **602**. Similarly, the beacon tag **632** on the trailer **603** is within the transmission range of the signpost **626** at the rear of the trailer **602**, but is outside the transmission range of the signpost **627** at the rear end of the trailer **603**. Further, the beacon tag **633** on the trailer **604** is within the transmission range of the signpost **627** at the rear of the trailer **603**, but is outside the transmission range of the signpost **628** which is at the rear of the trailer **604**.

With this in mind, it will be recognized that, while the tractor **601** and the trailer **602** are releasably coupled to each other, the beacon tag **631** on the trailer will periodically transmit a beacon signal which includes its own unique beacon code and which also includes the unique signpost code of the signpost **623** on the tractor **601**. Thus, based on beacon signals from the tag **631**, the server **502** (FIG. **11**) will know that the trailer **602** is currently coupled directly to the tractor **601**.

Similarly, the beacon signals from tag **632** advise the system that the trailer **603** is currently coupled directly to the trailer **602**. Also, the beacon signals from the tag **633** advise the system that the trailer **604** is currently coupled directly to the trailer **603**. With all of this information, the control system knows not only that the tractor **601** and the trailers **602–604** are all currently coupled together to form the train **600**, but also knows the precise order in which they respectively appear in the train from the front to the rear. That is, the control system knows that the tractor **601** precedes the trailer **602**, which in turn precedes the trailer **603**, which in turn precedes the trailer **604**. As trains are assembled and disassembled, in order to meet the varying needs of the facility, the control system always has direct immediate knowledge of exactly which tractor and trailers are combined to form any particular train.

As discussed above in association with the ULD **381** of FIG. **9**, the ULDs **606–608** each have two additional beacon tags attached to a lower portion thereof, on opposite side-walls near diagonally opposite corners of the bottom wall. One such beacon tag is visible in FIG. **12** on each of the ULDs **606–608**, and these tags are respectively identified with reference numerals **641–643**.

The beacon tag **641** on the ULD **606** is within the transmission range of the signpost **626** on the trailer **602** which carries that ULD. The tag **641** thus transmits a beacon signal which includes its own unique beacon code, and also the unique signpost code for the signpost **626**. Thus, the control system knows that the ULD **606** is currently supported on the trailer **602**. In a similar manner, the beacon tags **642** and **643** transmit respective beacon signals which include respective signpost codes from the signposts **627** and **628**, and which respectively advise the control system that the ULDs **607** and **608** are respectively supported on the trailers **603** and **604**. The beacon tags **641–643** are sufficiently low on the ULDs **606–608** that they pass below the transmission ranges of the signposts which are on the ceiling **613**, such as the signpost **612**.

If the ULD **606** had been placed on the trailer **602** with an orientation rotated 180° about a vertical axis from the orientation shown in FIG. **12**, then the beacon tag **641** would be near the front left corner of the trailer **602**, and the third beacon tag on the ULD **606** (which is not visible in FIG. **12**)

would be near the signpost 626 on the right rear corner of the trailer 602. That third beacon tag would thus carry out the function of transmitting beacon signals which contain the signpost code of signpost 626 and which advise the control system that the ULD 606 is currently supported on the trailer 602. With the ULD 606 in this alternate position, the beacon tag 641 would be outside the transmission ranges of the signposts 623 and 626, and thus would not include any signpost code in its beacon signal. Consequently, by providing two beacon tags at diagonally opposite locations on the lower portion of each ULD, each ULD can be placed on a trailer with either of two different orientations, and it is thus not necessary for employees of the facility to be concerned about ensuring a particular orientation of each ULD when it is placed on a trailer.

The control system knows the location of the tractor 601 by virtue of the beacon signals issued by the beacon tag 611 on the tractor 601, which typically include the signpost code of one of the signposts on the ceiling, such as the signpost 612. Further, since the control system also knows which trailers are currently coupled to the tractor 601, and in what order, the system also knows the location of each of the trailers 602–604 which are coupled to the tractor 601 as the tractor 601 moves through the installation shown in FIG. 10. Further, the system knows the location of each of the ULDs 606–608 being transported by the train 600, not only based on the beacon signals transmitted by the tags 616–618 on top of the ULDs, but also based on beacon signals transmitted by the beacon tags 641–643 on the lower portions of the ULDs, because the latter associate the ULDs with the train 600, and the control system knows the location of the train.

FIG. 13 is a diagrammatic side view which shows a forklift 651 that has a signpost 652 provided on its vertically movable lift. A pallet 654 is removably supported on the lift, and has a beacon tag 653 provided on it. The transmission range of the signpost 652 is indicated by a broken line circle in FIG. 13, and it will be noted that the tag 653 on the pallet 654 is within this transmission range when the pallet is supported on the lift. Consequently, the tag 653 will transmit beacon signals which include its own unique beacon code and also the signpost code of the signpost 652. Thus, the control system will know from these beacon signals that the pallet 654 is presently being transported by the forklift 651. If the control system knows the items which are currently supported on the pallet, the system will also know where those items are.

It would also be possible to provide beacon tags 656 and 657 on each of the items 658 and 659 on the pallet 654. If the transmission range of the signpost 652 is configured so that tags 656 and 657 are within that transmission range, the tags 656–657 will transmit respective beacon signals which directly advise the system that the items 658–659 are being transported by the forklift 651. Alternatively, the signpost 652 could be provided on the pallet 654, and the beacon tag 653 could be omitted from the pallet 654. In that case, beacon signals from the tags 656–657 would advise the control system of the fact that the items 658–659 are currently on a mobile device which is the pallet 654.

The forklift 651 has a signpost 661 mounted on a post which extends upwardly from the top of the cab. The signpost 661 transmits signpost signals that have a transmission range which does not reach the items 658–659 supported on the lift of the forklift 651. However, beacon tags 662–664 are provided at spaced locations on the ceiling, and each will be within the transmission range of the signpost 661 when the forklift 651 is disposed approximately below it. Thus, based on beacon signals from the tags

662–664, the control system can track movement of the forklift 651 through the facility using a technique of the type described above in association with FIG. 8. As an alternative, it will be recognized that the signpost 661 can be replaced with a beacon tag, and the beacon tags 662–664 can be replaced with signposts, in which case the control system would track the forklift 651 using a technique of the type described above in association with FIG. 7.

FIG. 14 is a diagrammatic side view showing the tail section of an airplane 671, and also a device 672 which is commonly known as a loader, and which can be used to load or unload an airplane. The airplane has a gate or door 674 which has pivoted down to create an approximately horizontal platform. The loader has a horizontal platform 676, and has a powered scissors support for the platform which is capable of vertically raising and lowering the platform, so that it can be vertically aligned with the gate 674 of the airplane.

The platform 676 of the loader 672 supports a pallet 677, and the pallet in turn supports several items, one of which is designed by reference numeral 678. Each of the items on the pallet has a beacon tag on it, one of the beacon tags being indicated by reference numeral 679. The platform supports a signpost 682. In response to signpost signals from the signpost 682, the tags 679 on the items 678 transmit respective beacon signals which advise the control system that these items are all currently on the loader 672 that has the signpost 682. An operator 683 carries a handheld unit 684, which is equivalent to the handheld units 571–574 discussed above in association with FIG. 11. Further, the operator carries a portable signpost 686, which can be used to turn off all of the tags 679 as the items 678 are loaded onto the airplane. The control system can verify whether or not all tags have in fact been turned off by evaluating whether any of the tags are still transmitting beacon signals, and can provide feedback through the handheld unit 684 as to whether any tags that should be off are still on. Conversely, of course, if the airplane was being unloaded, the portable signpost could be used to turn on the tags 679, and the tags 679 would then begin transmitting respective beacon signals containing the signpost code of signpost 682, in order to notify the control system that the associated items are all on the loader 672.

FIG. 15 is a diagrammatic side view of an apparatus 700 which includes a conveyor 702 and a signpost 703 that is stationarily mounted above the conveyor 702 on some not-illustrated support, such as a ceiling. The signpost 703 is equivalent to the signpost shown at 11 in FIG. 1. The effective transmission range of the signpost signals transmitted by the signpost 703 is indicated by a broken line in FIG. 15.

A pallet 706 is supported on the conveyor 702, and is being moved in a direction 704 by the conveyor. The pallet 706 has several items on it, one of which is designated by reference numeral 707. Each of the items 707 is a container for packages that are subject to overnight delivery. Each of the items 707 has on it a respective beacon tag, one of which is indicated by reference numeral 708. Each of the beacon tags is equivalent to the beacon tag shown at 12 in FIG. 1.

As the pallet 706 is moved in the direction 704 by the conveyor 702, each of the items 707 on the pallet will pass through the transmission range of the signpost signals from the signpost 703. Thus, each of the beacon tags 708 will transmit to a not-illustrated reader a beacon signal which includes the unique beacon code for that particular beacon tag, and also the signpost code of the signpost 703. Thus, the control system coupled to the reader will be able to

determine, based on the receipt of all these beacon signals within a certain window of time, which items 707 are presently disposed on the pallet 706. The control system will also know that these items 707 and the pallet 706 are currently in a location where they are passing the stationary signpost 703.

It would also be possible to provide a further beacon tag 711 on the pallet 706 itself. As the pallet 706 passes the signpost 703, the tag 711 will transmit a beacon signal which includes its own unique beacon code, as well as the signpost code from the signpost 703, so that the control system knows precisely which pallet is currently passing the signpost 703 with the items 707 supported thereon.

In some circumstances, a problem can be encountered with the arrangement shown in FIG. 15, where successive palettes are moving along the conveyor 702 with relatively little spacing between them. In this regard, after the beacon tags 708 on the items 707 move out of the transmission range of the signpost 703, they will still continue to transmit beacon signals that include the signpost code of the signpost 703, for the period of time required to complete the beacon sequence which was discussed above in association with FIGS. 4 and 5. If another pallet is moving along the conveyor 702 a short distance behind the illustrated palette 706, the items on that next pallet may move into the transmission range of the signpost 703 and begin transmitting beacon signals with its signpost code while the beacon tags on the illustrated pallet 706 are still winding up their beacon sequences. In that case, the control system would find it difficult to distinguish which items are on which of the two pallets. FIG. 16 is a diagrammatic sectional side view of an apparatus 730 which is intended to avoid this problem.

More specifically, the apparatus 730 is an alternative embodiment of the apparatus 700 shown in FIG. 15. The apparatus 730 includes all of the elements discussed above in association with apparatus 700. In addition, it includes a sensor 732 which is stationarily mounted, for example on the same ceiling or support as the signpost 703. The sensor 732 is positioned upstream of the signpost 703 with respect to the direction 704 in which materials move along the conveyor 702. In fact, the sensor 732 is positioned so that it can detect a new pallet 706 and the items thereon, just about the time that they first begin to move into the transmission range of the signpost 703. The sensor 732 may be any of several different types of known sensors, such as a sensor which detects the motion of the pallet 706, or a proximity sensor which senses the distance to the nearest item below it.

The sensor 732 is coupled by wires to the signpost 703. When the sensor 732 detects that a new pallet 706 with items 707 thereon is about to move into the transmission range of the signpost 703, the sensor 732 sends a signal to the signpost 703, and the signpost 703 responds by altering its signpost code. The signpost 703 could, for example, increment its signpost code. The signpost 703 could thus be assigned several unique and successive signpost codes which the control system knew were all associated with a single signpost, and could successively cycle through those codes. Alternatively, it would be possible to simply toggle the most significant bit of the signpost code.

As the tags 708 on the new pallet move into the transmission range of the signpost 703, they will begin receiving signpost signals from the signpost 703 that contain the modified signpost code, and they will begin transmitting beacon signals that include their own unique beacon codes, and also the modified signpost code from the signpost 703. It will be recognized that, if the tags 708 on the preceding pallet have all moved out of the transmission range of the

signpost 703 before the signpost 703 modifies its signpost code, it will be very easy for the control system to distinguish the items 707 on one pallet from the items 707 on the next successive pallet. However, even if the pallets are closer than this, as illustrated in FIG. 16, such that some of the tags 708 on each of the two adjacent pallets are all within the transmission range of the signpost 703 at the point in time when the signpost 703 changes its signpost code, the control system can still accurately distinguish the items on one pallet from the items on another pallet.

In more detail, and as noted above, the control system will be aware of all of the possible signpost codes associated with the signpost 703. Further, the beacon tags on the first pallet will each have transmitted beacon signals that contain the prior signpost code. If those beacon tags suddenly begin transmitting beacon signals with the modified signpost code, the control system can detect this and ignore those beacon signals. In contrast, the beacon tags on the next palette will have been sending beacon signals which do not contain any signpost code, and will suddenly begin transmitting beacon signals which include the modified signpost code. The control system can detect this and thus distinguish the beacon tags on items disposed on one palette from the beacon tags on items disposed on the other palette.

The present invention provides a number of technical advantages. One such technical advantage results from the capability to dynamically vary the duration of the signals transmitted by the tag. For example, the amount of information transmitted and thus the duration may be shorter when the tag is not currently receiving a signal from any signpost, whereas the duration may be longer when the tag is receiving a signpost signal and needs to include a signpost code in the transmitted signals. This helps reduce the cumulative amount of time during which the tag is actively transmitting, which in turn can facilitate compliance with governmental regulations.

Another advantage results from the capability for the tag to vary at least one of its transmission rate and transmission power in a dynamic manner, based on operating conditions such as whether the tag is currently receiving signals from a signpost. This also helps to facilitate compliance with governmental regulations. Further, these types of variations can help to reduce the likelihood of collisions with signals transmitted by other tags, while ensuring that the reader reliably receives at least one transmission from each tag within a reasonably short period of time.

Although several selected embodiments have been illustrated and described in detail, it will be understood that other substitutions and alterations are possible without departing from the spirit and scope of the present invention, as defined by the following claims.

What is claimed is:

1. An apparatus comprising a tag having circuitry which includes:

- a receiver section operable to receive wireless signpost signals that each include a signpost code; and
- a transmitter section operable to transmit wireless beacon signals which each include a beacon code associated with said tag, said transmitter section being responsive to receipt by said receiver section of a respective said signpost signal for including in at least one said beacon signal the signpost code from the received signpost signal;

wherein said transmitter section is operable to transmit said beacon signals in a selected one of first and second formats which are different, said transmitter section using said first format in response to receipt of one of

said signpost signals and using said second format in response to the absence of receipt of any of said signpost signals for a specified time interval, said first format including a signpost field containing the signpost code from the most recently received signpost signal, and said second format lacking said signpost field and being shorter in length than said first format.

2. A method comprising the steps of:

receiving in a receiver section of a tag wireless signpost signals that each include a signpost code; and

transmitting from a transmitter section of said tag wireless beacon signals which each include a beacon code associated with said tag, said transmitting step including the steps of:

causing said transmitter section to be responsive to receipt by said receiver section of a respective said signpost signal for including in at least one said beacon signal the signpost code from the received signpost signal; and

causing said transmitter section to transmit said beacon signals in a selected one of first and second formats which are different, said transmitter section using said first format in response to receipt of one of said signpost signals and using said second format in response to the absence of receipt of any of said signpost signals for a specified time interval, said first format including a signpost field containing the signpost code from the most recently received signpost signal, and said second format lacking said signpost field and being shorter in length than said first format.

3. An apparatus comprising a tag having circuitry which includes:

a receiver section operable to receive wireless signpost signals that each include a signpost code; and

a transmitter section operable to transmit wireless beacon signals which each include a beacon code associated with said tag, said transmitter section being responsive to receipt by said receiver section of a respective said signpost signal for including in at least one said beacon signal the signpost code from the received signpost signal;

wherein said transmitter section is responsive to receipt by said receiver section of one of said signpost signals for automatically effecting variation in a predetermined manner of at least one of a transmission power level and a transmission rate for said beacon signals.

4. An apparatus according to claim **3**, wherein said transmitter section is operative to carry out said variation by:

transmitting a first series of said beacon signals containing the signpost code at a first transmission power level; and

thereafter transmitting a second series of said beacon signals containing the signpost code at a second transmission power level which is higher than said first transmission power level, said first series being transmitted at a effective first rate which is substantially higher than an effective second rate at which said second series is transmitted.

5. An apparatus according to claim **4**,

wherein said transmission of said first series is carried out by defining a plurality of successive first time slots and transmitting each of said beacon signals of said first series at a substantially randomly selected time within a respective said first time slot; and

wherein said transmission of said second series is carried out by defining a plurality of successive second time

slots and transmitting each of said beacon signals of said second series at a substantially randomly selected time within a respective said second time slot, said second time slots being substantially longer than said first time slots.

6. An apparatus according to claim **4**, wherein said first rate is at least ten times said second rate.

7. An apparatus according to claim **4**, wherein said transmitter section is further operative to carry out said variation by inhibiting transmission of said beacon signals during a time interval which occurs between transmission of said first and second series.

8. An apparatus according to claim **4**, wherein said transmitter section is further operative to carry out said variation by transmitting, after said first series and before said second series, a third series of said beacon signals containing the signpost code at said first transmission power level and at an effective third rate which is less than said first rate and greater than said second rate.

9. An apparatus according to claim **8**, wherein said transmission of said third series is carried out by defining a plurality of successive third time slots and transmitting each of said beacon signals of said third series at a substantially randomly selected time within a respective said third time slot, said third time slots being substantially longer than said first time slots and substantially shorter than said second time slots.

10. An apparatus according to claim **8**, wherein said first rate is approximately ten times said third rate, and said third rate is approximately ten times said second transmission rate.

11. An apparatus according to claim **8**, wherein said transmitter section is further operative to carry out said variation by inhibiting transmission of said beacon signals during each of first and second time intervals, said first time interval occurring between said first and third series, and said second time interval occurring between said third and second series.

12. A method, comprising the steps of:

receiving in a receiver section of a tag wireless signpost signals that each include a signpost code; and

transmitting from a transmitter section of said tag wireless beacon signals which each include a beacon code associated with said tag, said transmitting step including the steps of:

causing said transmitter section to be responsive to receipt by said receiver section of a respective said signpost signal for including in at least one said beacon signal the signpost code from the received signpost signal; and

causing said transmitter section to be responsive to receipt by said receiver section of one of said signpost signals for automatically effecting variation in a predetermined manner of at least one of a transmission power level and a transmission rate for said beacon signals.

13. A method according to claim **12**, wherein said step of automatically effecting variation includes the steps of:

transmitting a first series of said beacon signals containing the signpost code at a first transmission power level; and

thereafter transmitting a second series of said beacon signals containing the signpost code at a second transmission power level which is higher than said first transmission power level, said first series being transmitted at a effective first rate which is substantially higher than an effective second rate at which said second series is transmitted.

31

- 14.** A method according to claim **13**, wherein said step of transmitting said first series is carried out by defining a plurality of successive first time slots and transmitting each of said beacon signals of said first series at a substantially randomly selected time within a respective said first time slot; and
- wherein said step of transmitting said second series is carried out by defining a plurality of successive second time slots and transmitting each of said beacon signals of said second series at a substantially randomly selected time within a respective said second time slot, said second time slots being substantially longer than said first time slots.
- 15.** A method according to claim **13**, including the step of selecting said first rate to be at least ten times said second rate.
- 16.** A method according to claim **13**, wherein said step of automatically effecting variation further includes the step of inhibiting transmission of said beacon signals during a time interval which occurs between transmission of said first and second series.
- 17.** A method according to claim **13**, wherein said step of automatically effecting variation further includes the step of transmitting, after said first series and before said second

32

series, a third series of said beacon signals containing the signpost code at said first transmission power level and at an effective third rate which is less than said first rate and greater than said second rate.

18. A method according to claim **17**, wherein said step of transmitting said third series is carried out by defining a plurality of successive third time slots and transmitting each of said beacon signals of said third series at a substantially randomly selected time within a respective said third time slot, said third time slots being substantially longer than said first time slots and substantially shorter than said second time slots.

19. A method according to claim **17**, including the steps of selecting said first rate to be approximately ten times said third rate, and selecting said third rate to be approximately ten times said second transmission rate.

20. A method according to claim **17**, wherein said step of automatically effecting variation further includes the step of inhibiting transmission of said beacon signals during each of first and second time intervals, said first time interval occurring between said first and third series, and said second time interval occurring between said third and second series.

* * * * *