



US006917405B2

(12) **United States Patent**
Kim

(10) **Patent No.:** **US 6,917,405 B2**
(45) **Date of Patent:** **Jul. 12, 2005**

(54) **TRANSFLECTIVE LIQUID CRYSTAL DISPLAY DEVICE HAVING A REFLECTIVE LAYER AT THE SAME LAYER AS SOURCE AND DRAIN ELECTRODES**

6,697,138 B2 * 2/2004 Ha et al. 349/114
6,819,379 B2 * 11/2004 Kubo et al. 349/114
2001/0024257 A1 * 9/2001 Kubo et al. 349/138
2002/0105604 A1 * 8/2002 Ha et al. 349/43
2002/0109797 A1 8/2002 Chung et al.

(75) Inventor: **Hong-Jin Kim**, Gumi-si (KR)

FOREIGN PATENT DOCUMENTS

(73) Assignee: **LG.Philips LCD Co., Ltd.**, Seoul (KR)

KR 2001-0087657 A 9/2001
KR 10 20000080501 6/2002

(*) Notice: Subject to any disclaimer, the term of this patent is extended or adjusted under 35 U.S.C. 154(b) by 0 days.

* cited by examiner

(21) Appl. No.: **10/918,456**

Primary Examiner—Tarifur R. Chowdhury

(22) Filed: **Aug. 16, 2004**

(74) *Attorney, Agent, or Firm*—McKenna Long & Aldridge LLP

(65) **Prior Publication Data**

US 2005/0012110 A1 Jan. 20, 2005

Related U.S. Application Data

(62) Division of application No. 10/607,203, filed on Jun. 27, 2003, now Pat. No. 6,794,228.

(30) **Foreign Application Priority Data**

Jul. 15, 2002 (KR) 10-2002-0041289

(51) **Int. Cl.**⁷ **G02F 1/1335**; G02F 1/1343

(52) **U.S. Cl.** **349/114**; 349/113; 349/139; 349/147

(58) **Field of Search** 349/43, 113, 114, 349/139, 147

(56) **References Cited**

U.S. PATENT DOCUMENTS

6,532,045 B2 * 3/2003 Chung et al. 349/43

(57) **ABSTRACT**

An array substrate for a transflective liquid crystal display device includes: a gate line on a substrate; a data line crossing the gate line, the gate line and the data line defining a pixel region having a transmissive portion and a reflective portion; a gate electrode connected to the gate line; source and drain electrode spaced apart from each other over the gate electrode, the source and drain electrode being spaced apart from each other, the source electrode being connected to the data line; a reflective layer having the same layer as the source and drain electrodes, the reflective layer being disposed in the pixel region and having a transmissive hole corresponding to the transmissive portion; and a pixel electrode connected to the drain electrode, the pixel electrode being disposed in the pixel region, wherein the source and drain electrodes and the reflective layer have multiple layers of metal, wherein a top layer of the multiple layers includes a reflective metallic material.

7 Claims, 12 Drawing Sheets

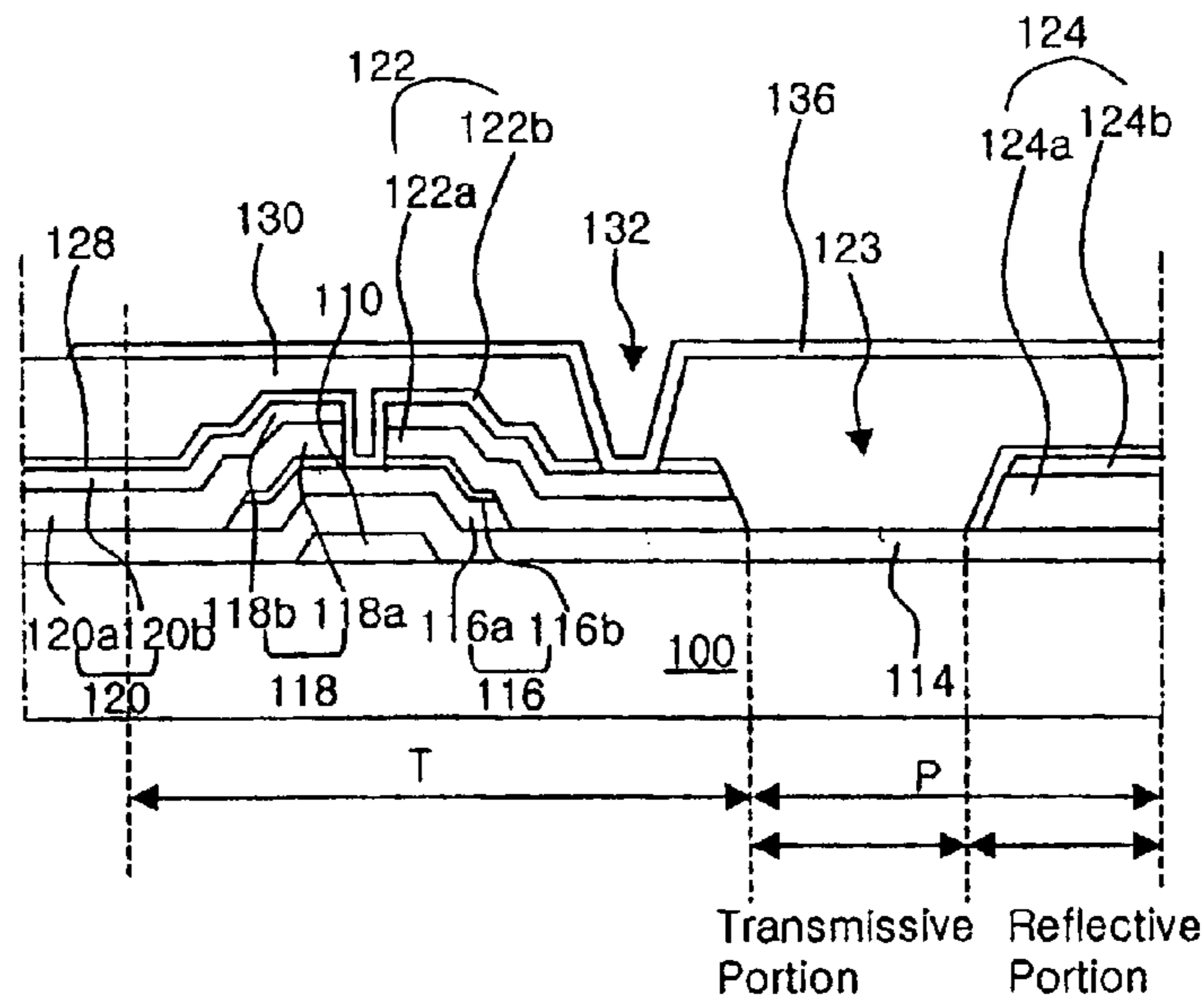

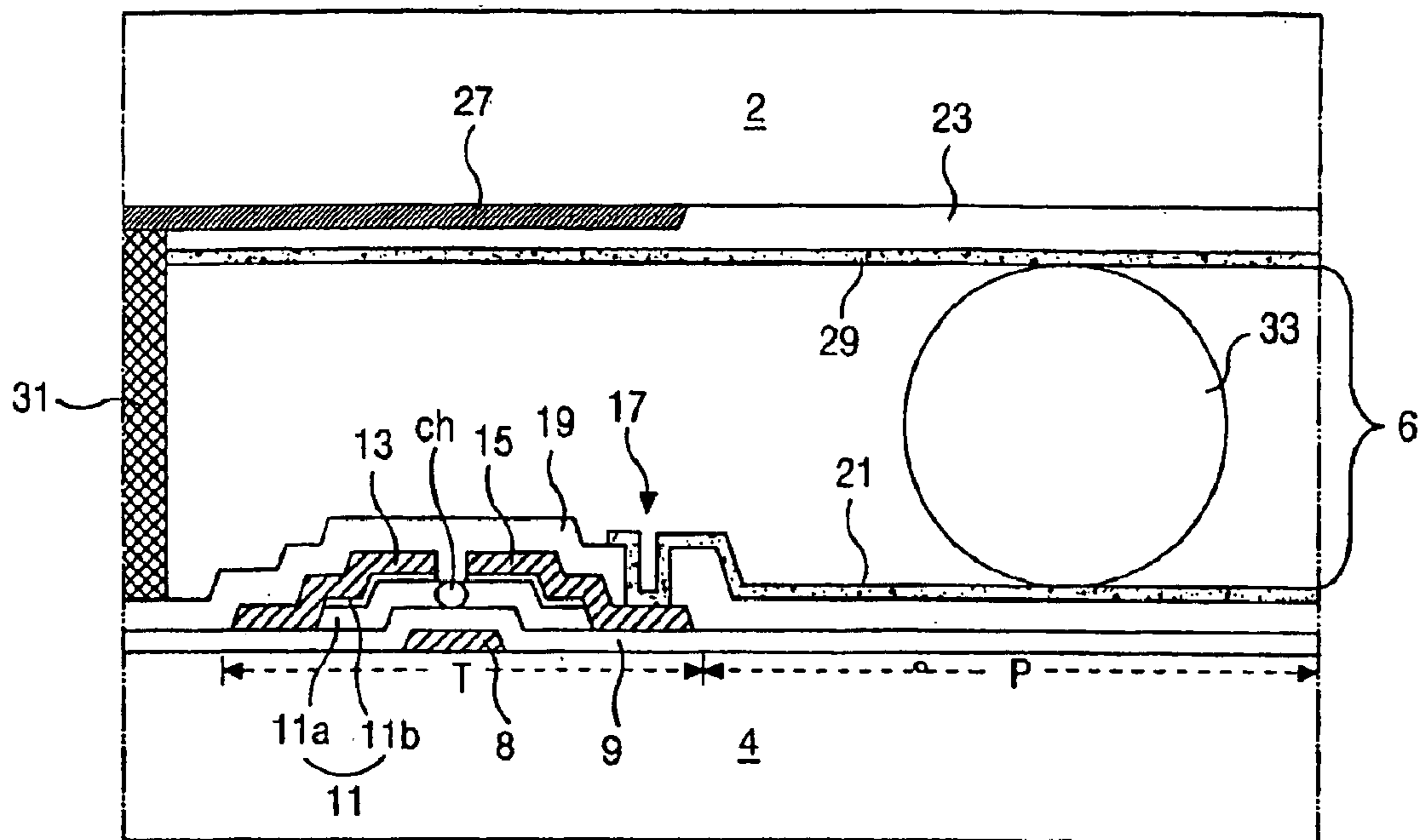

(related art)
FIG. 1

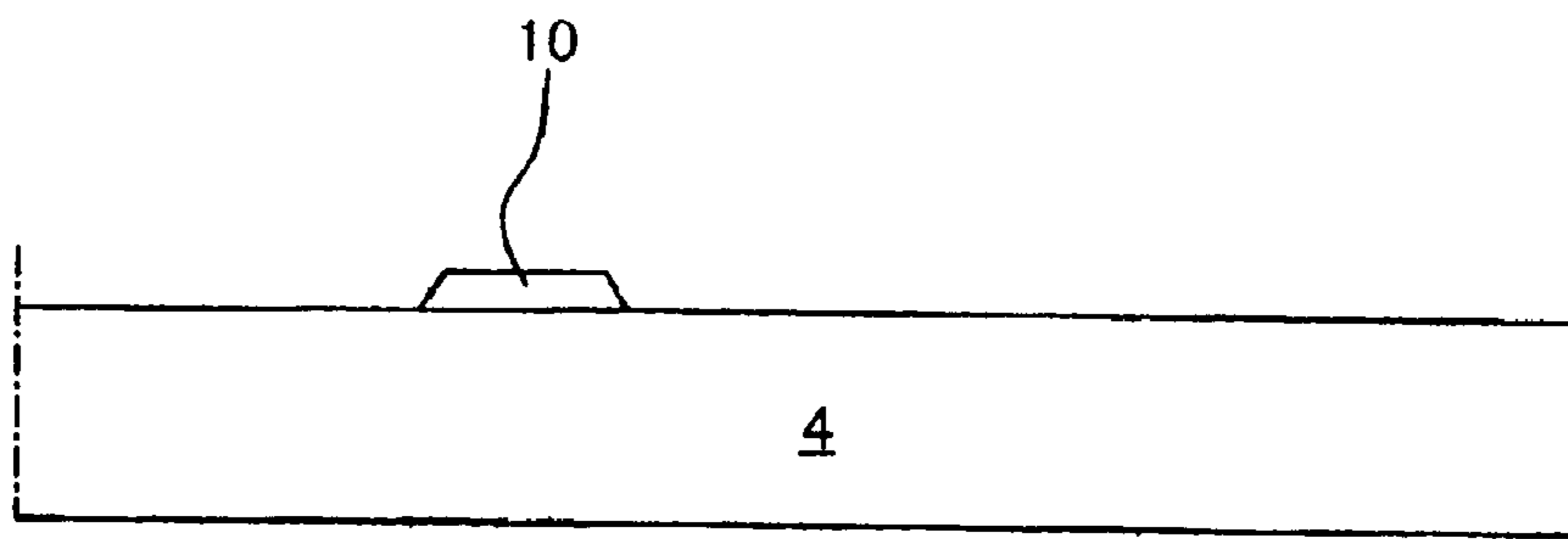

(related art)
FIG. 2A

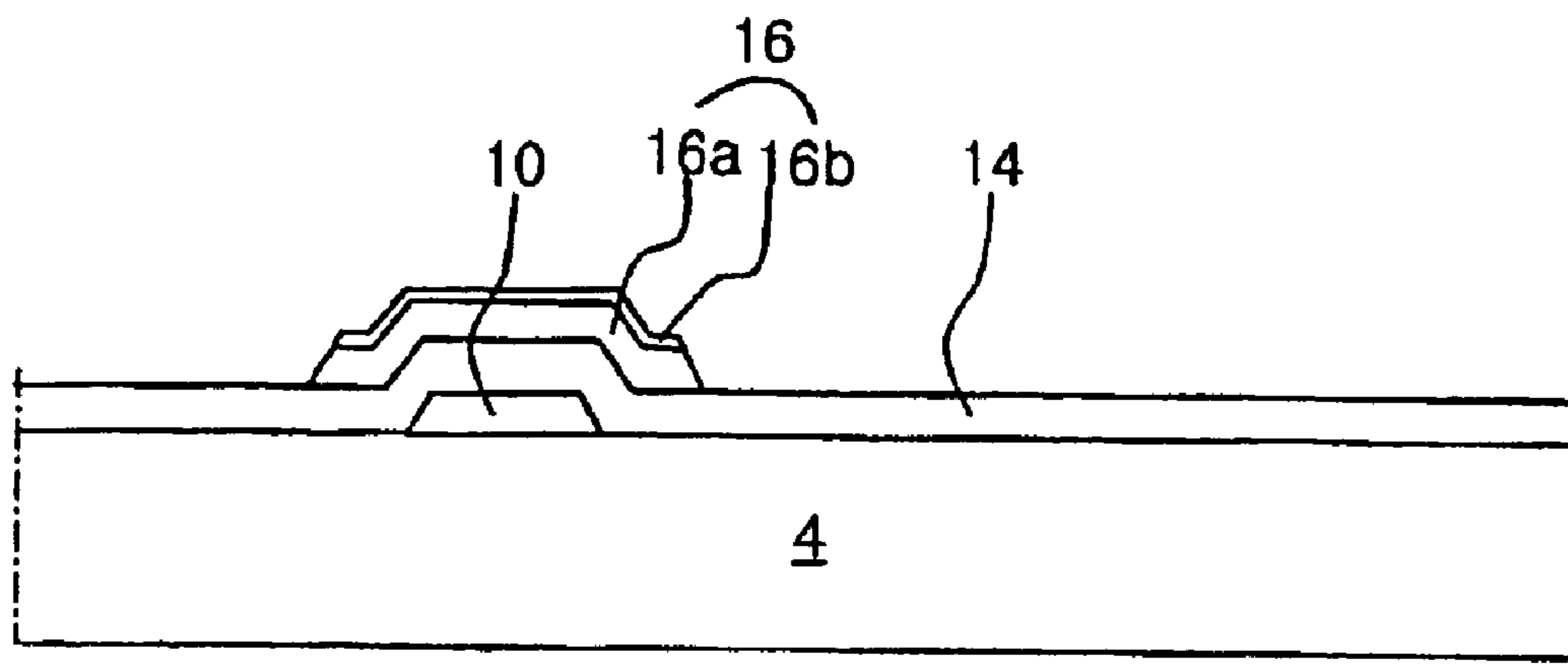

(related art)
FIG. 2B

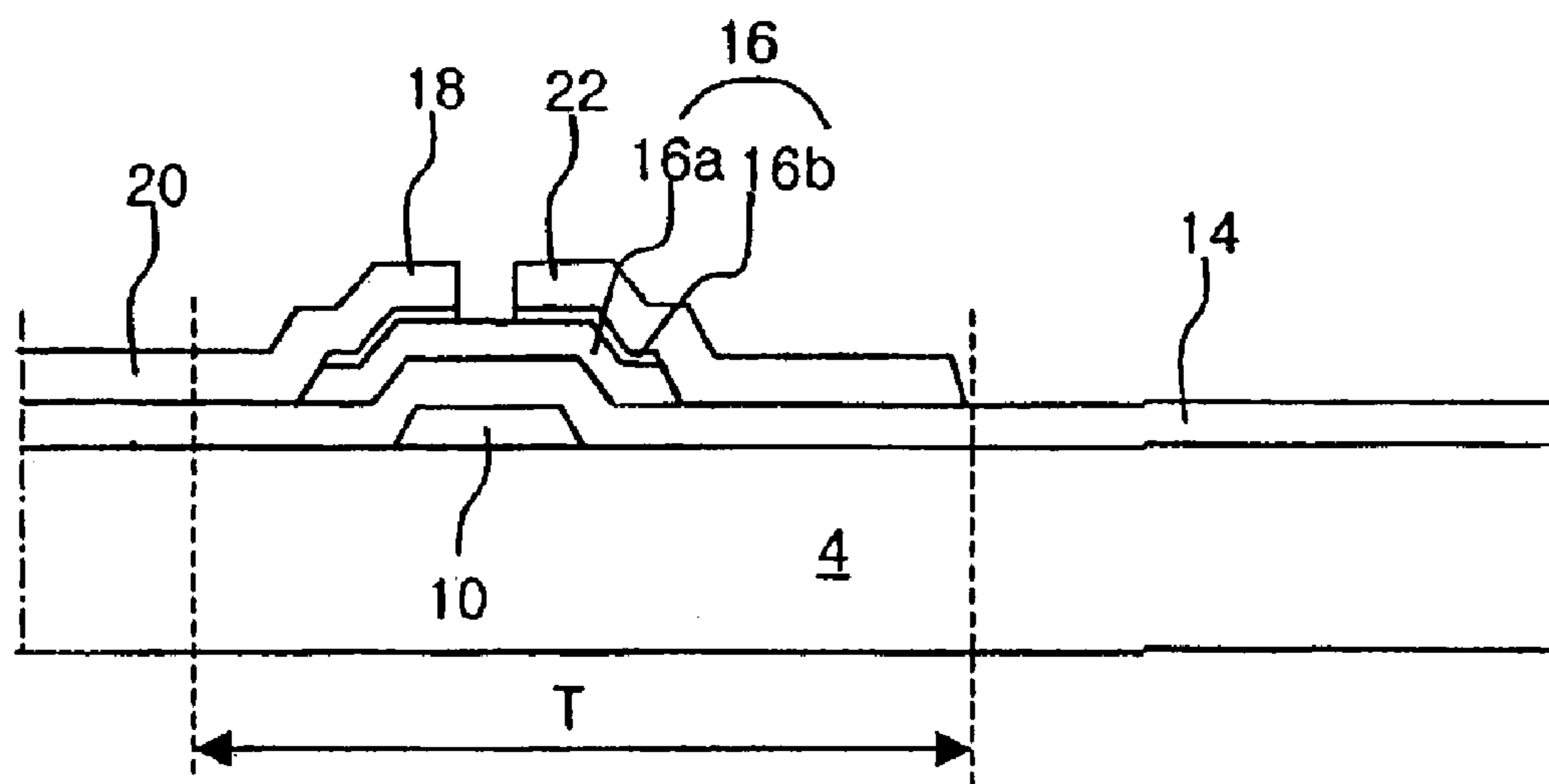

(related art)
FIG. 2C

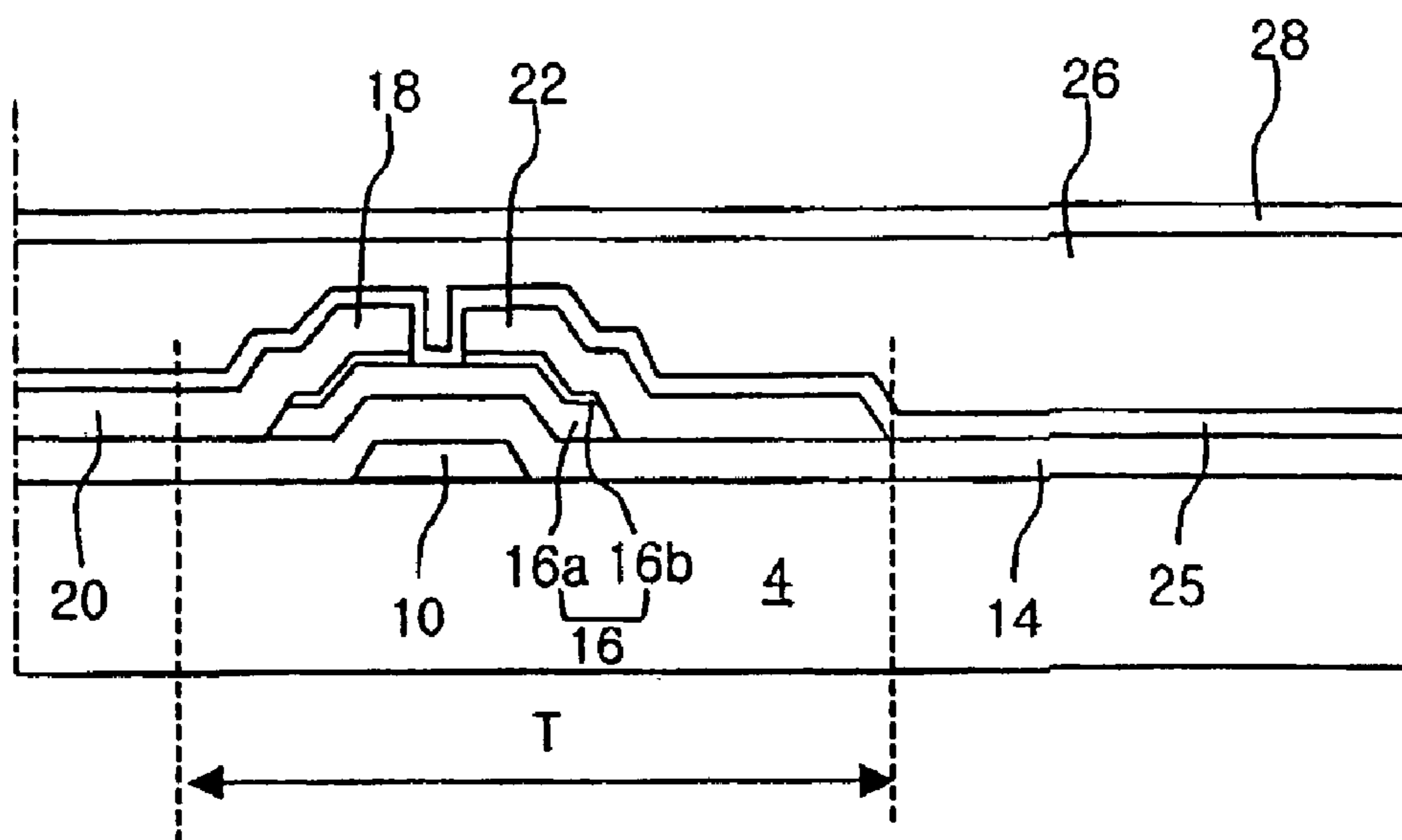

(related art)
FIG. 2D

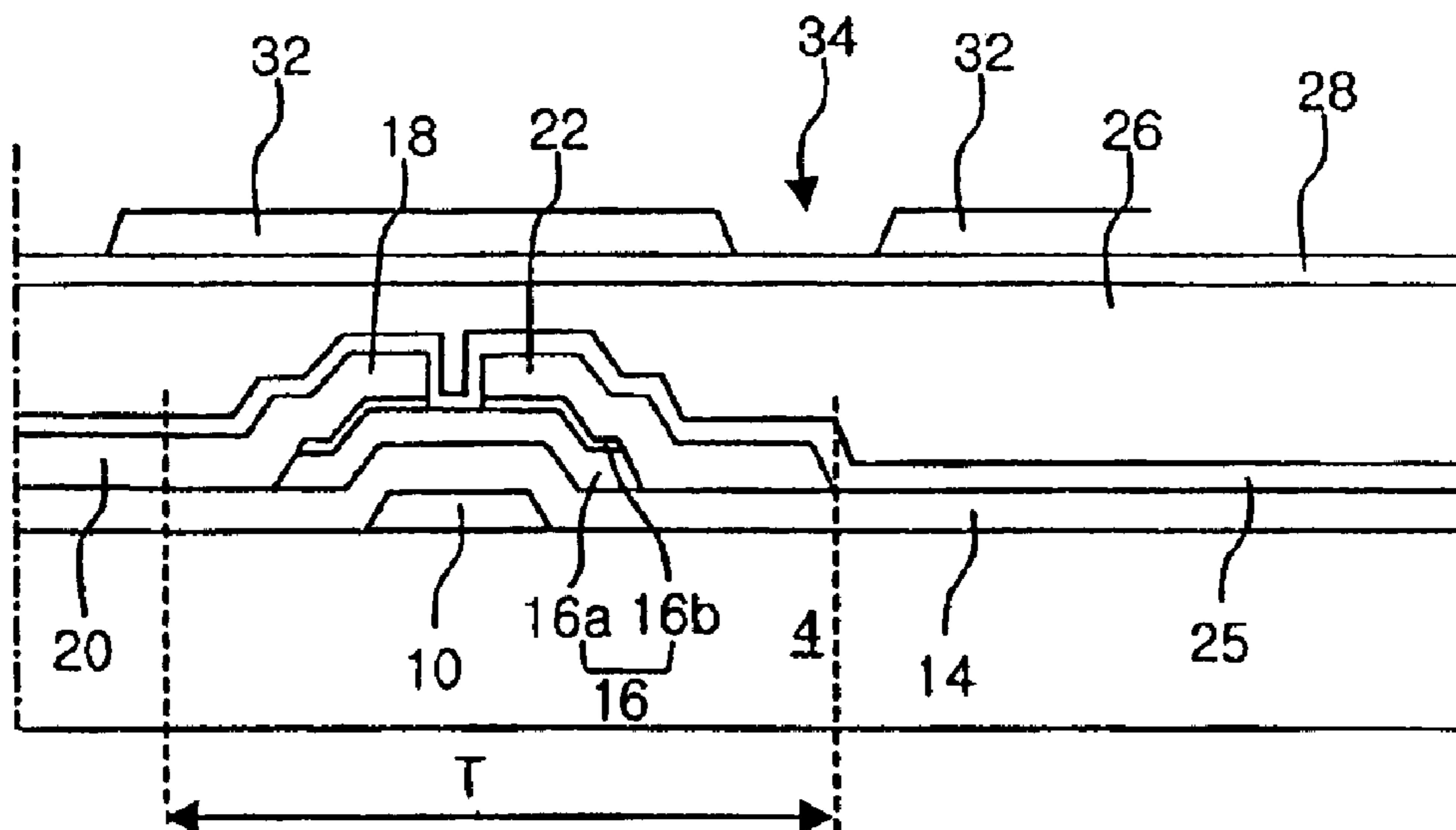

(related art)
FIG. 2E

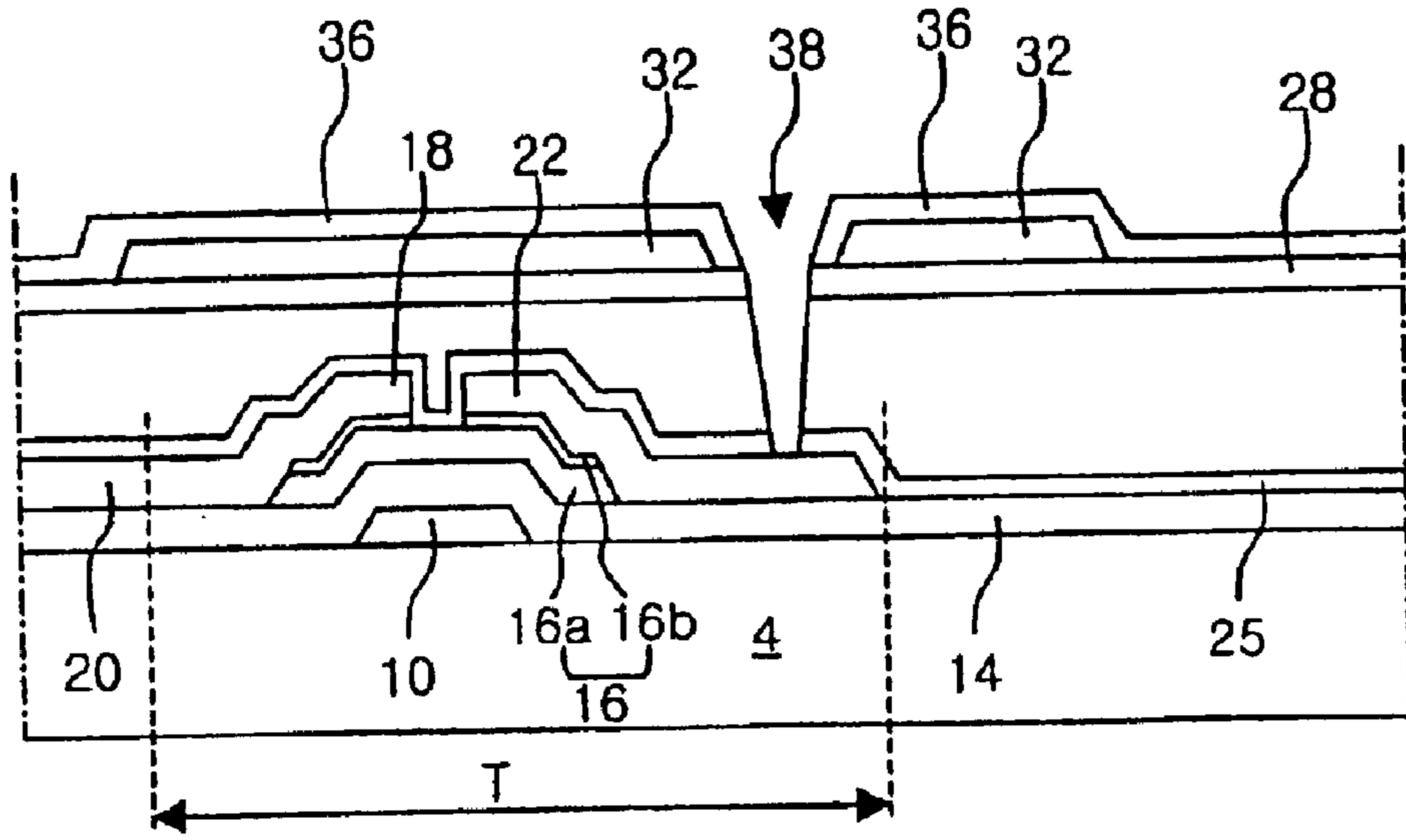

(related art)
FIG. 2F

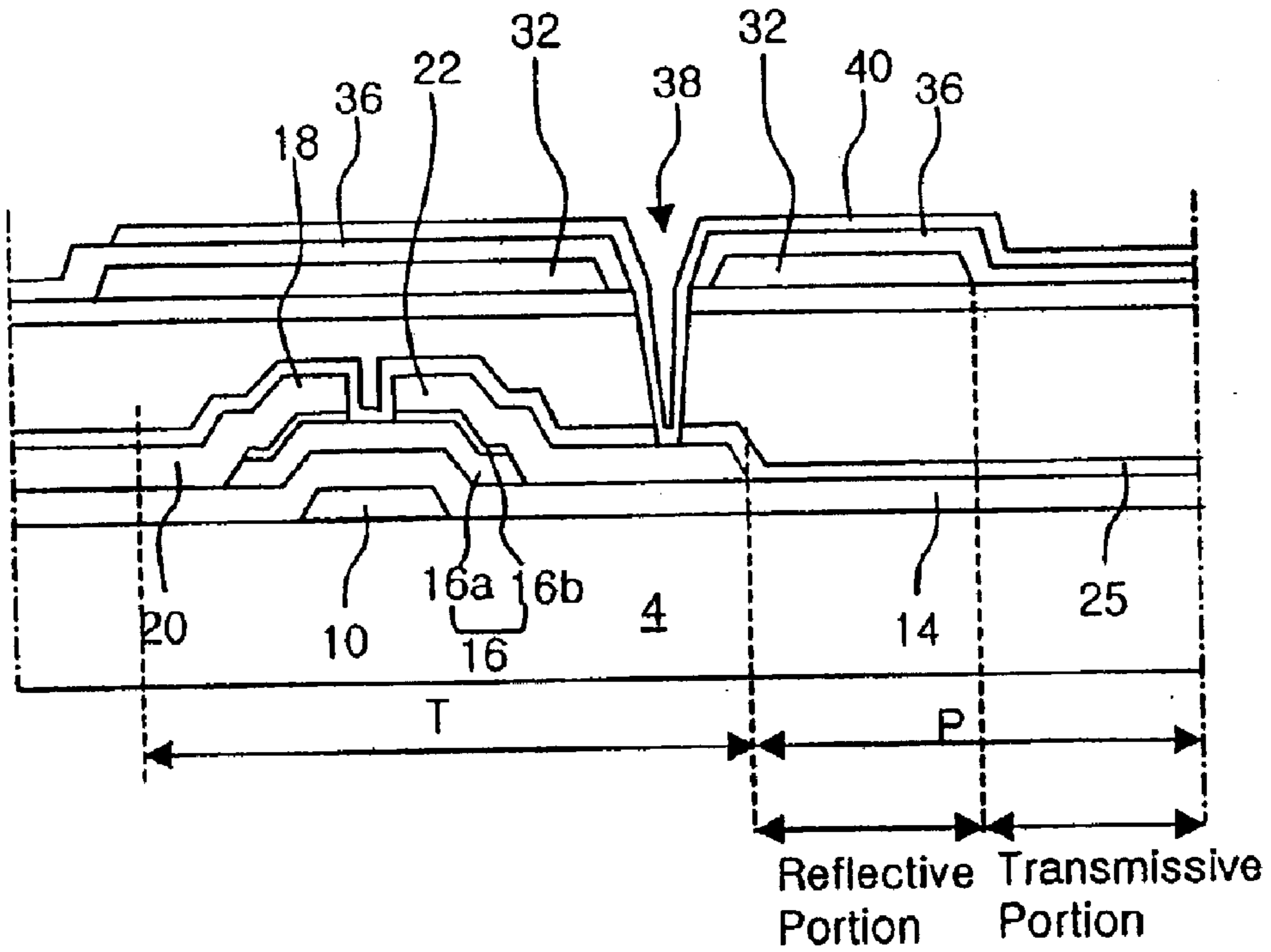

(related art)
FIG. 2G

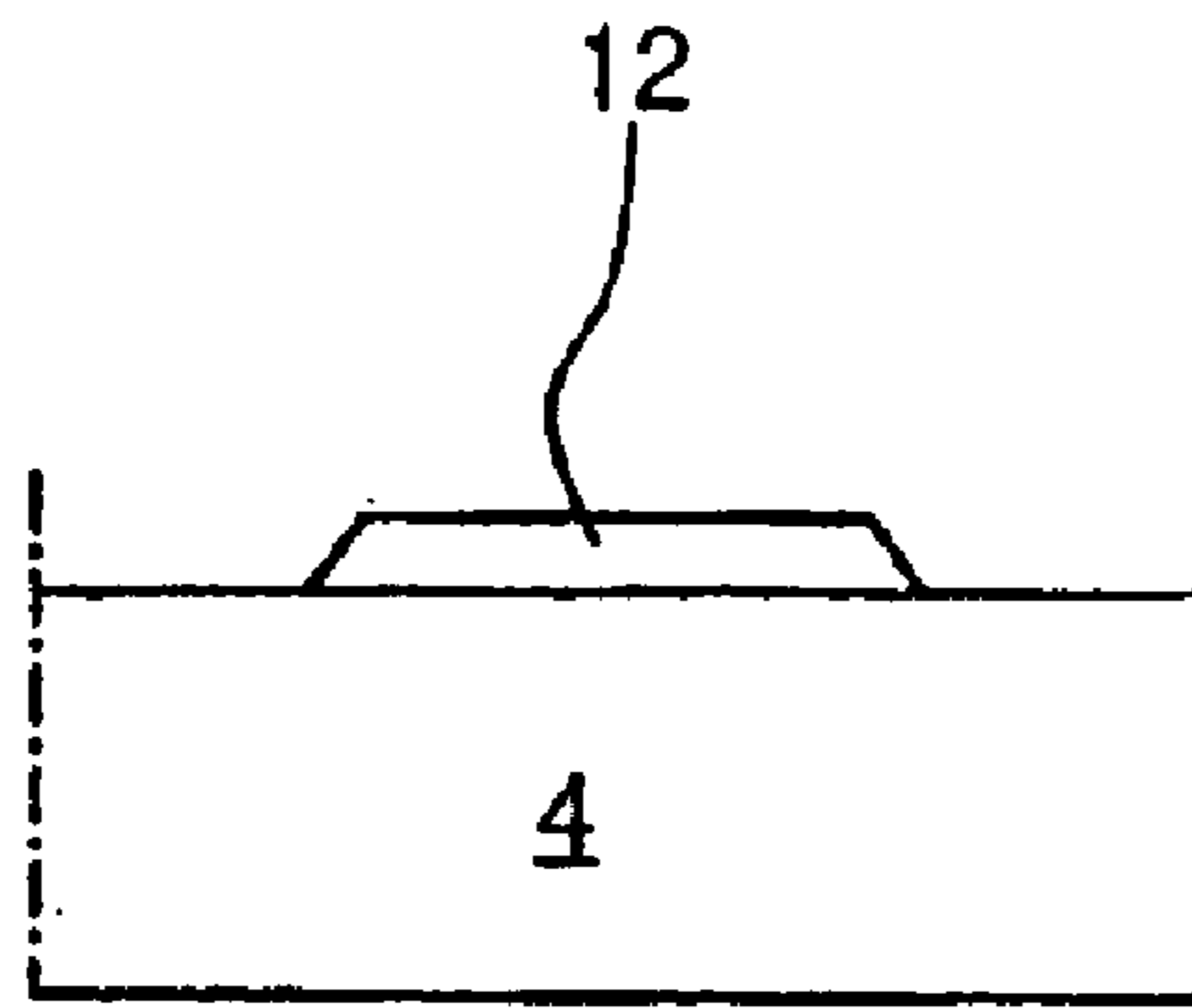

(related art)
FIG. 3A

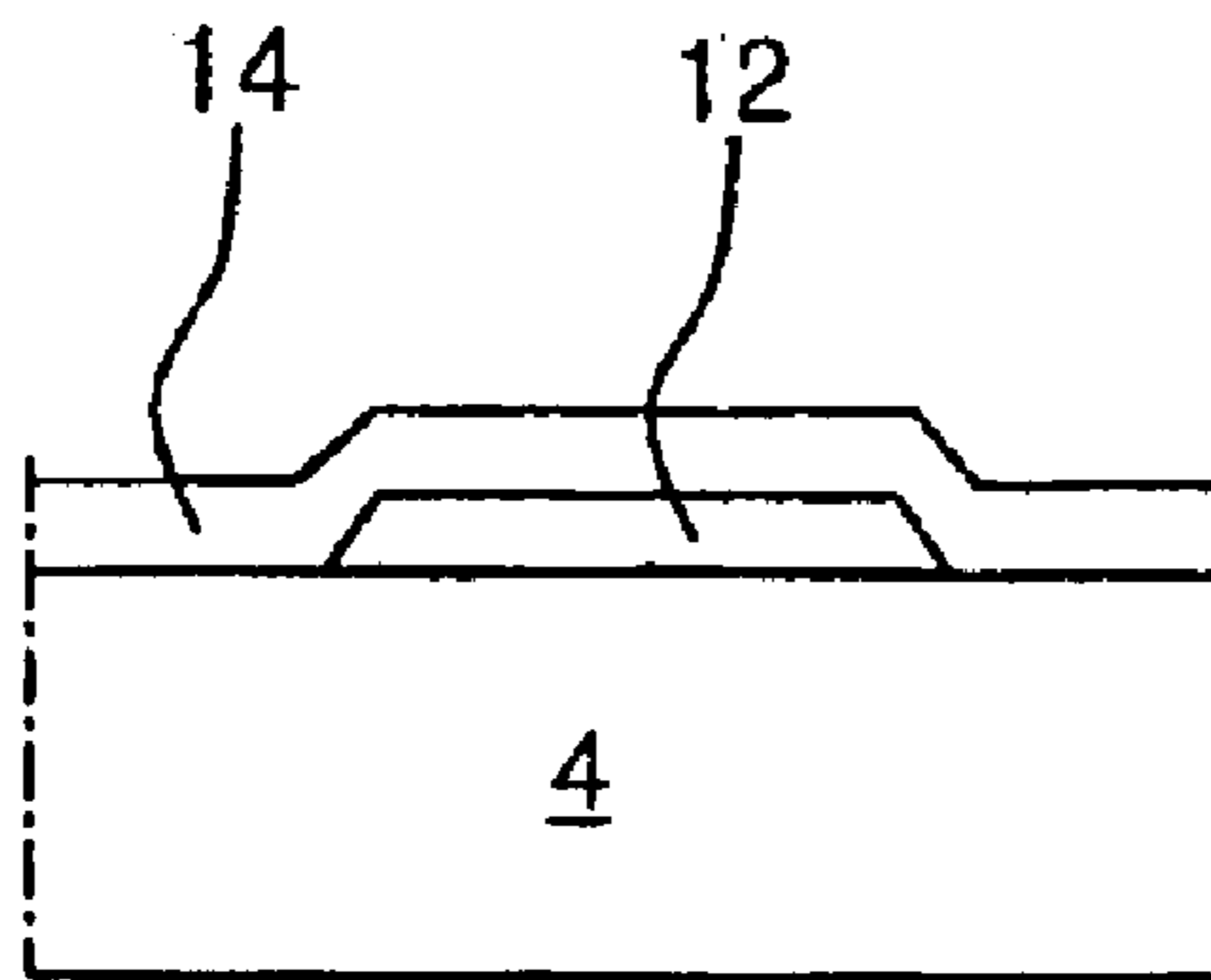

(related art)
FIG. 3B

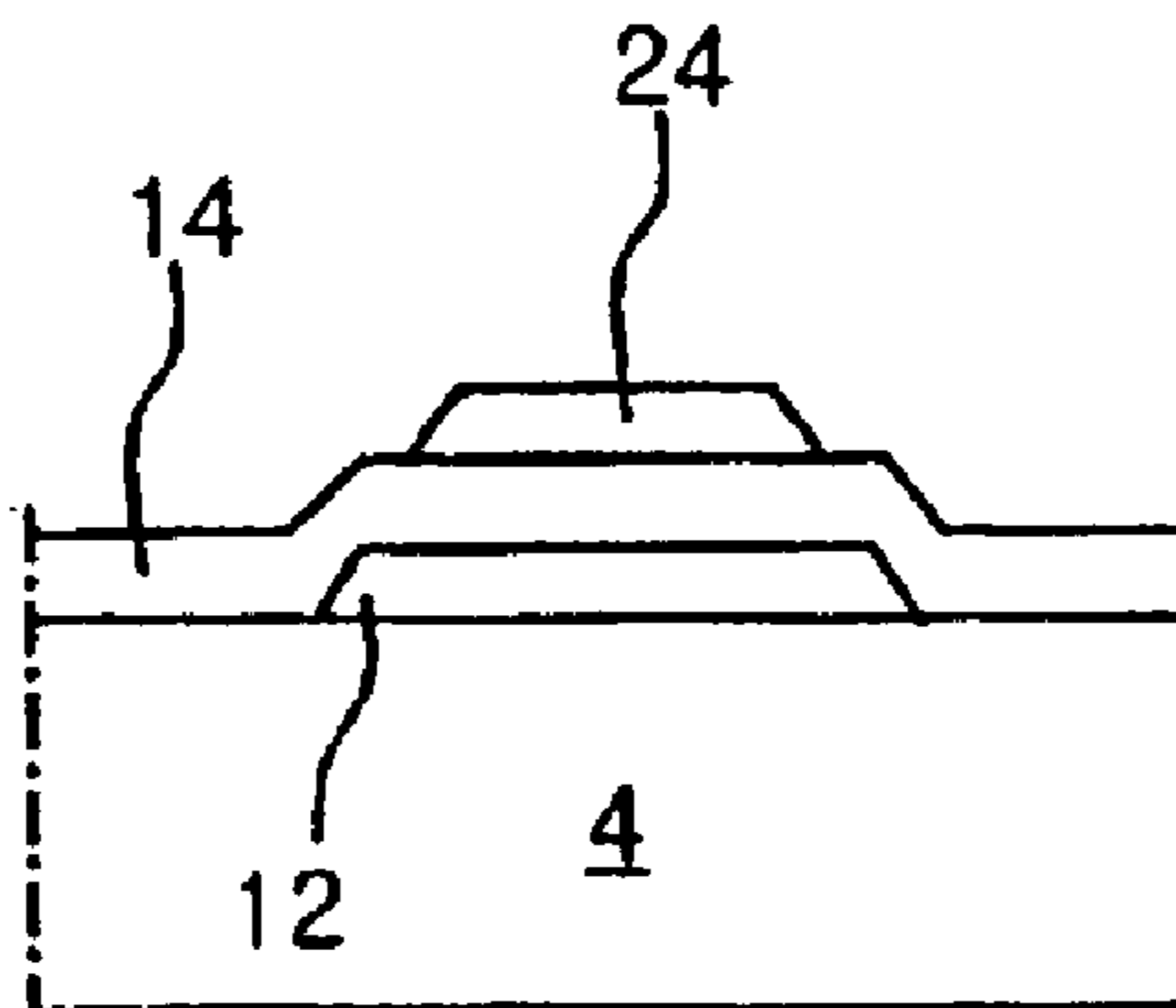

(related art)
FIG. 3C

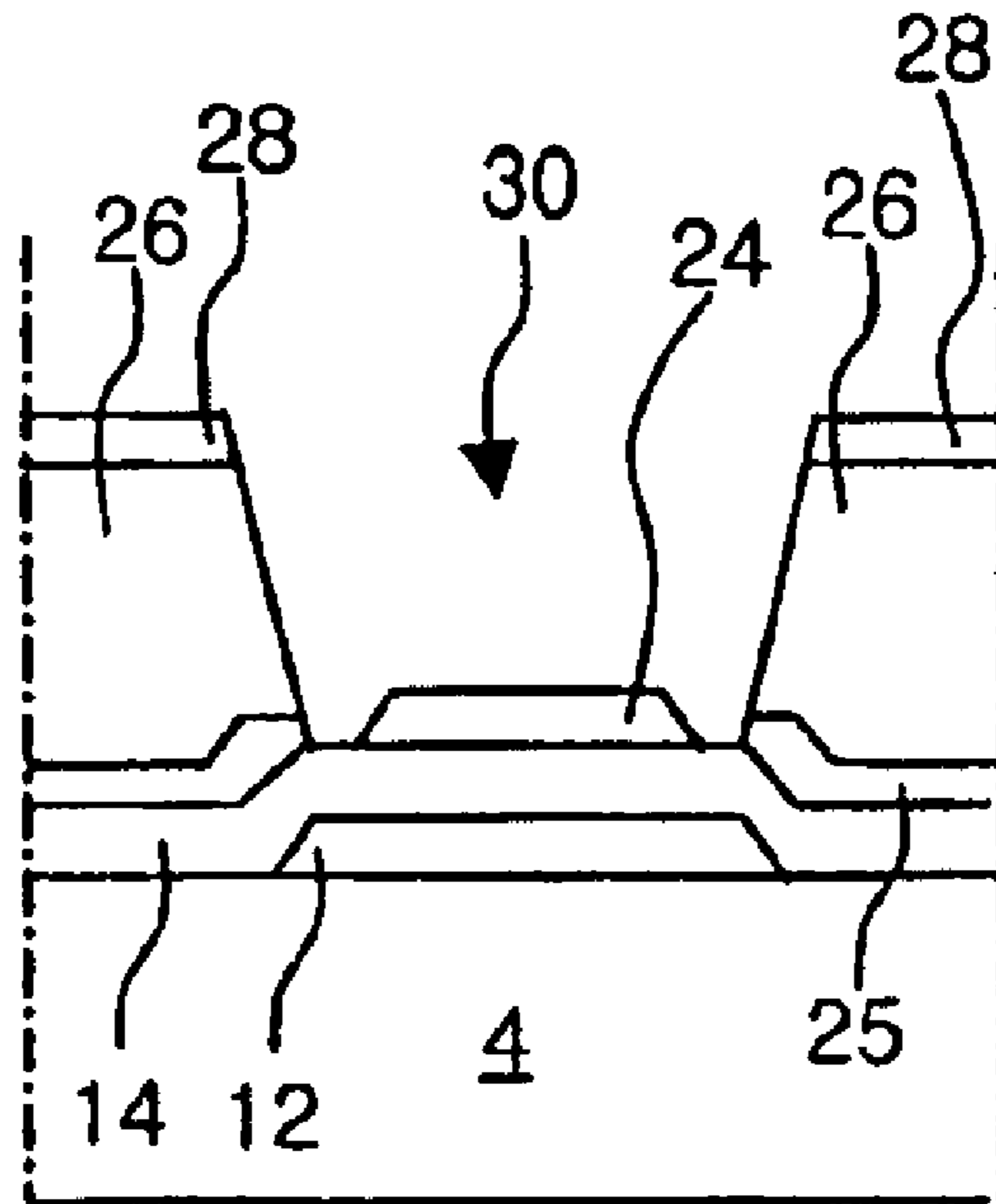

(related art)
FIG. 3D

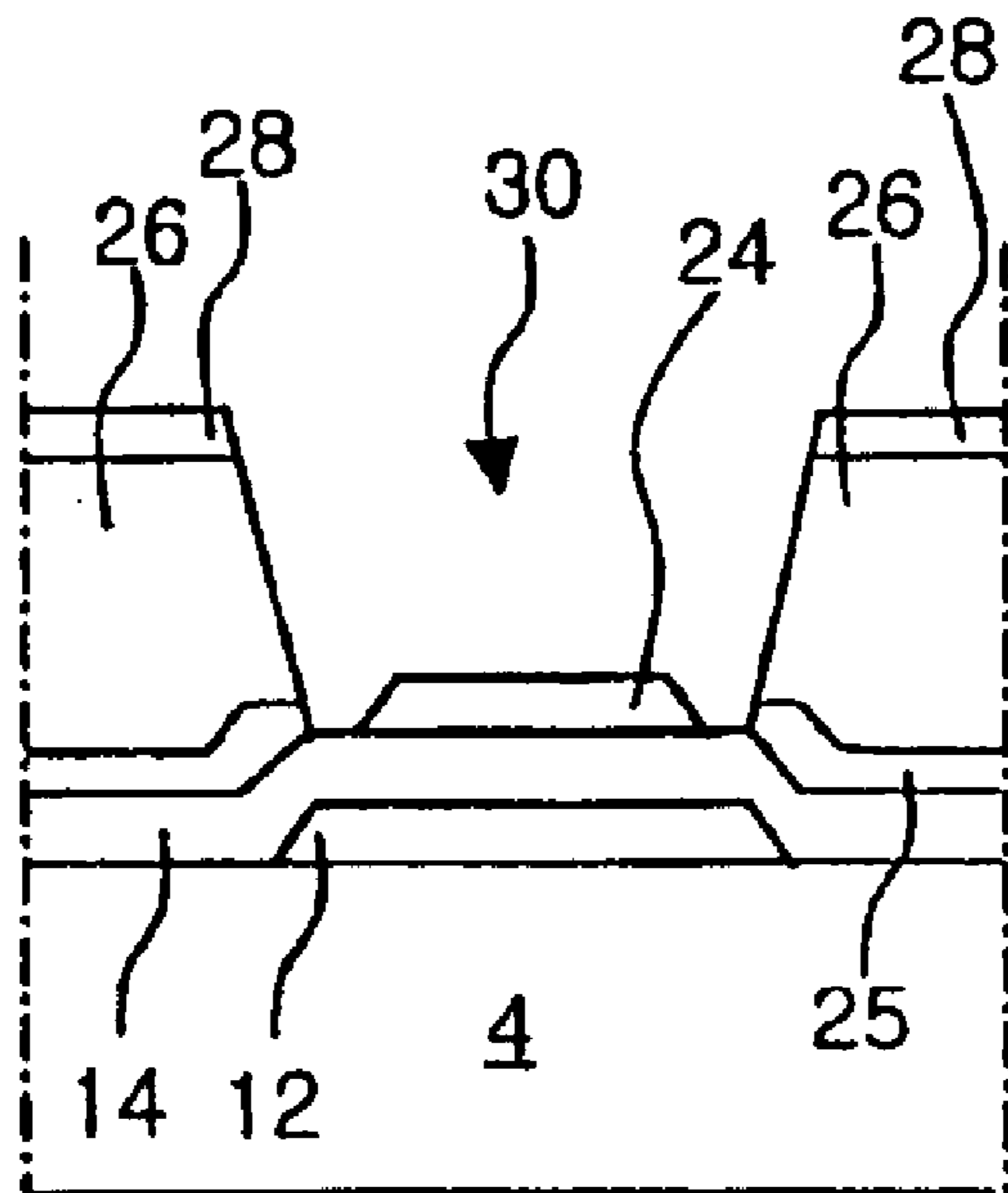

(related art)
FIG. 3E

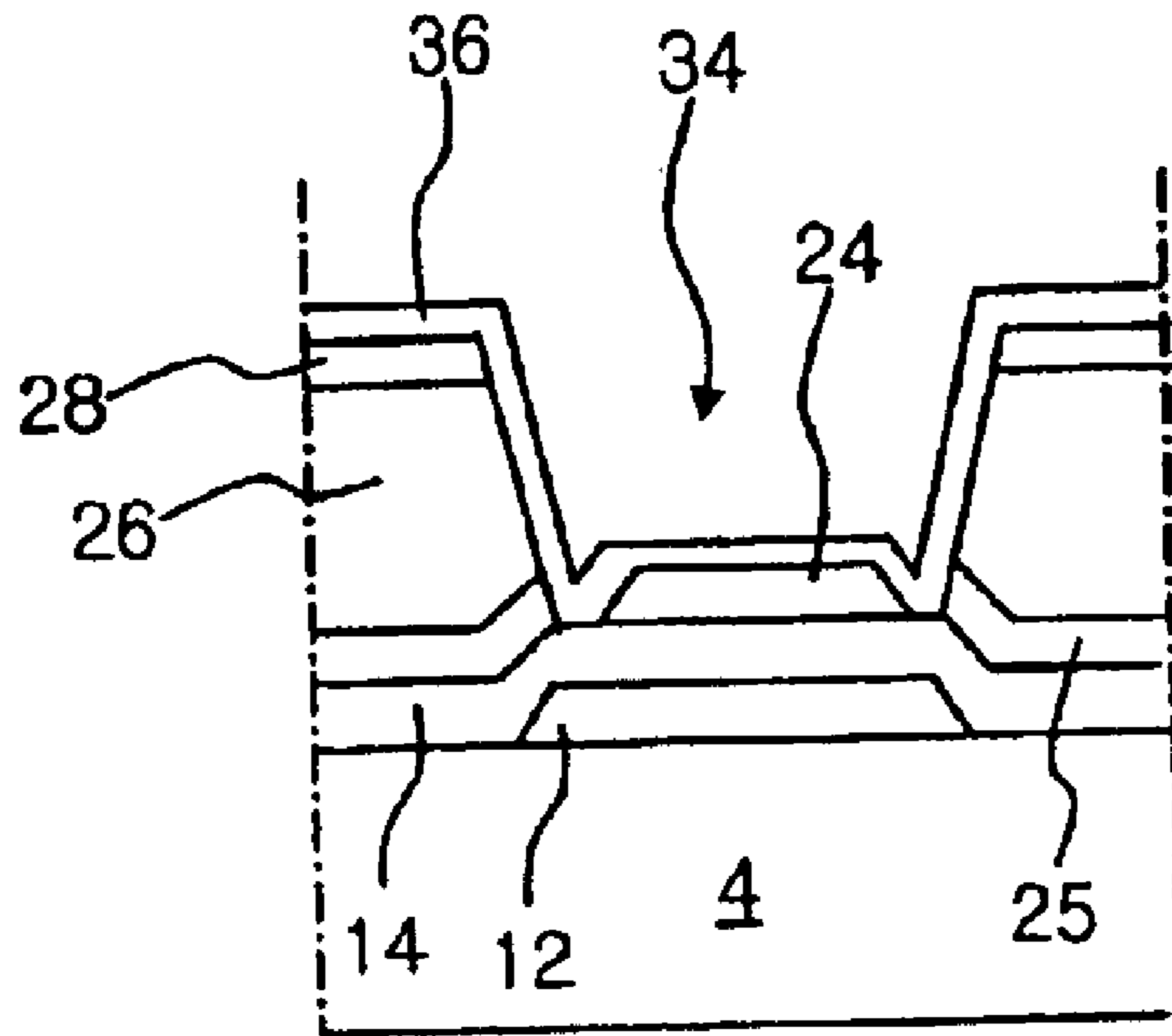

(related art)
FIG. 3F

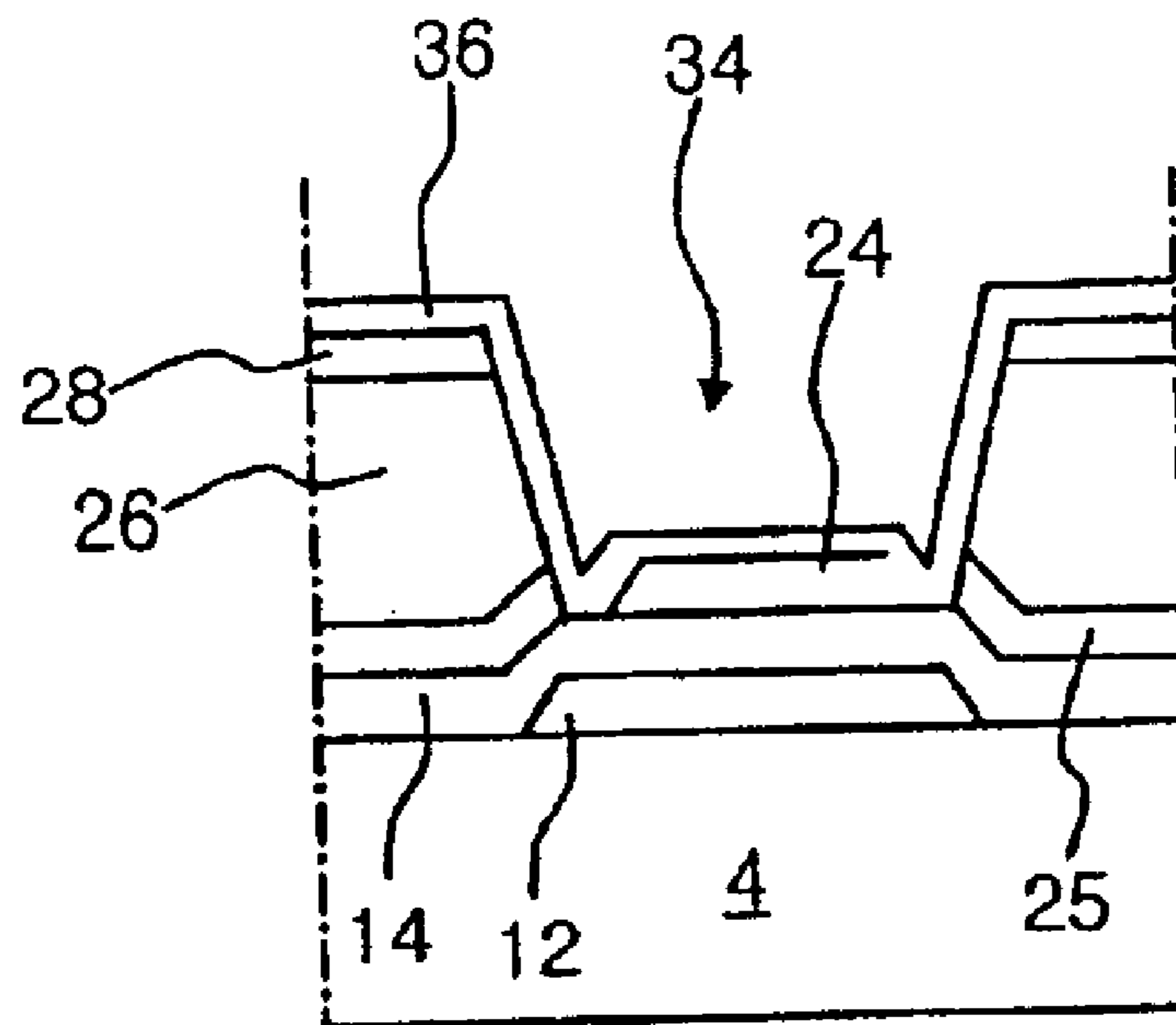

(related art)
FIG. 3G

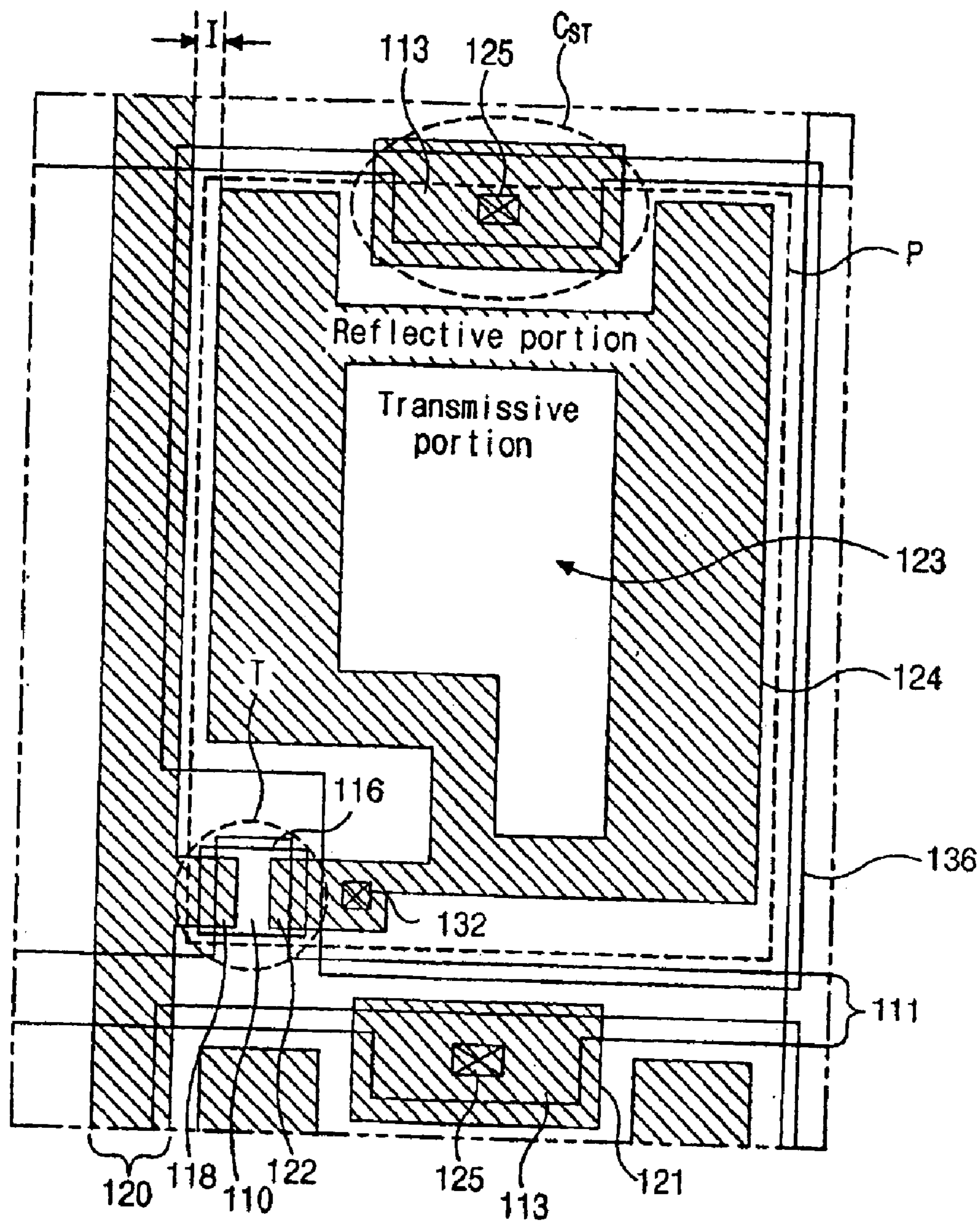

FIG. 4

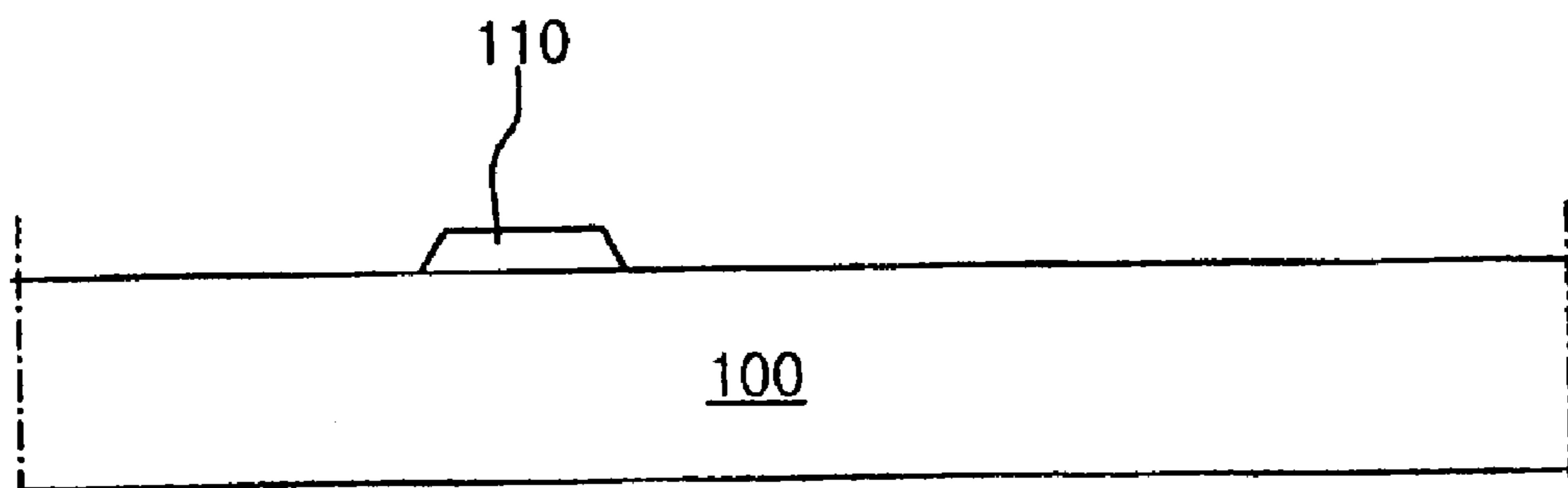

FIG. 5A

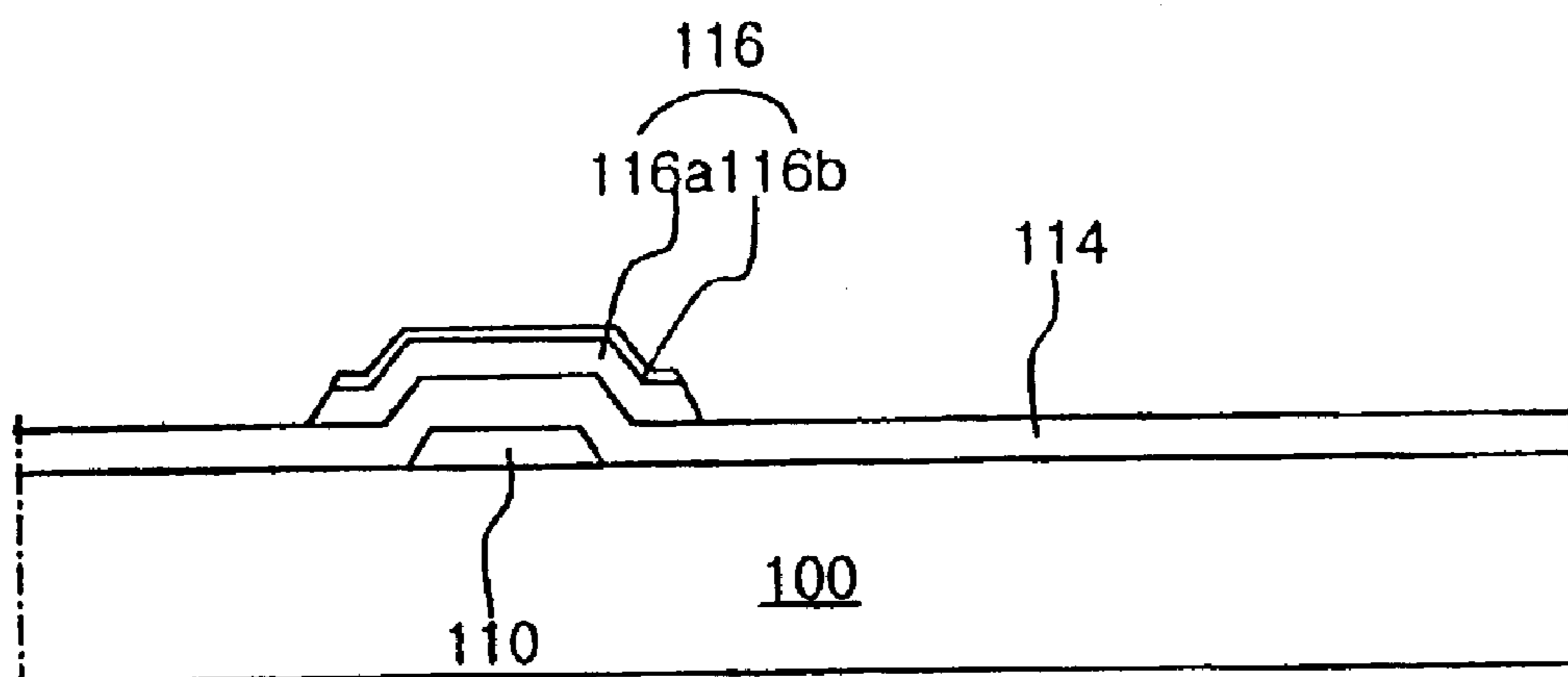

FIG. 5B

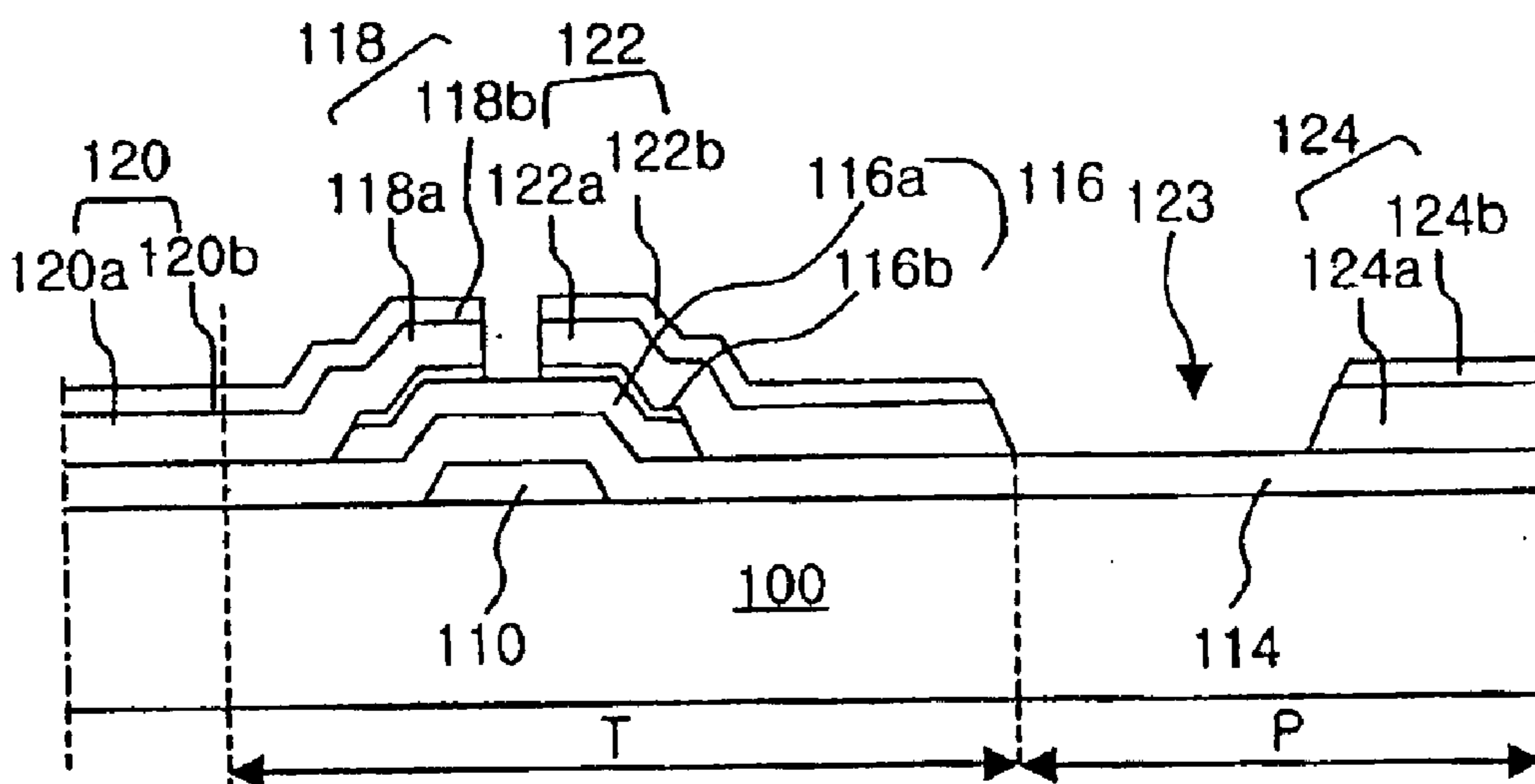

FIG. 5C

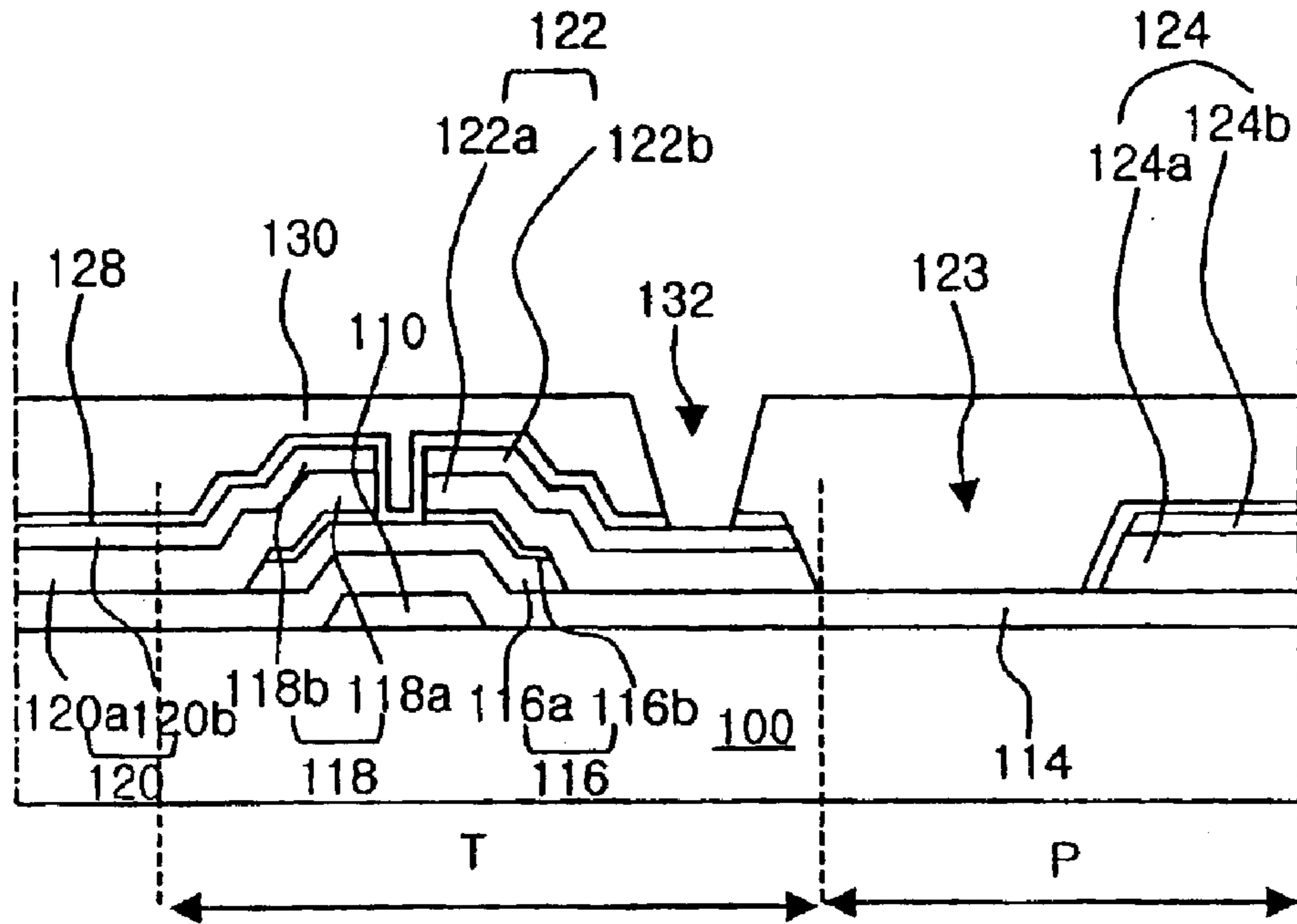

FIG. 5D

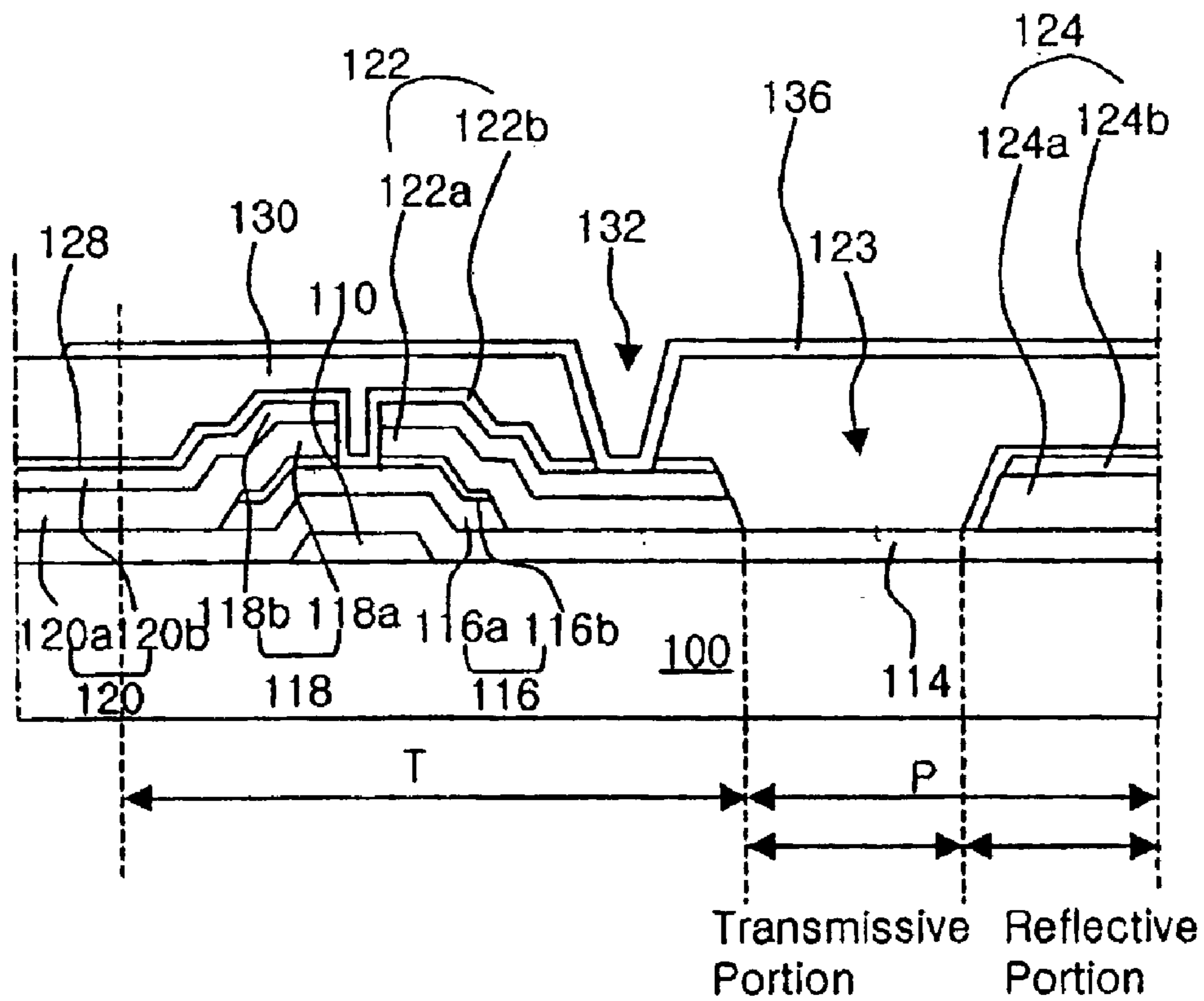

FIG. 5E

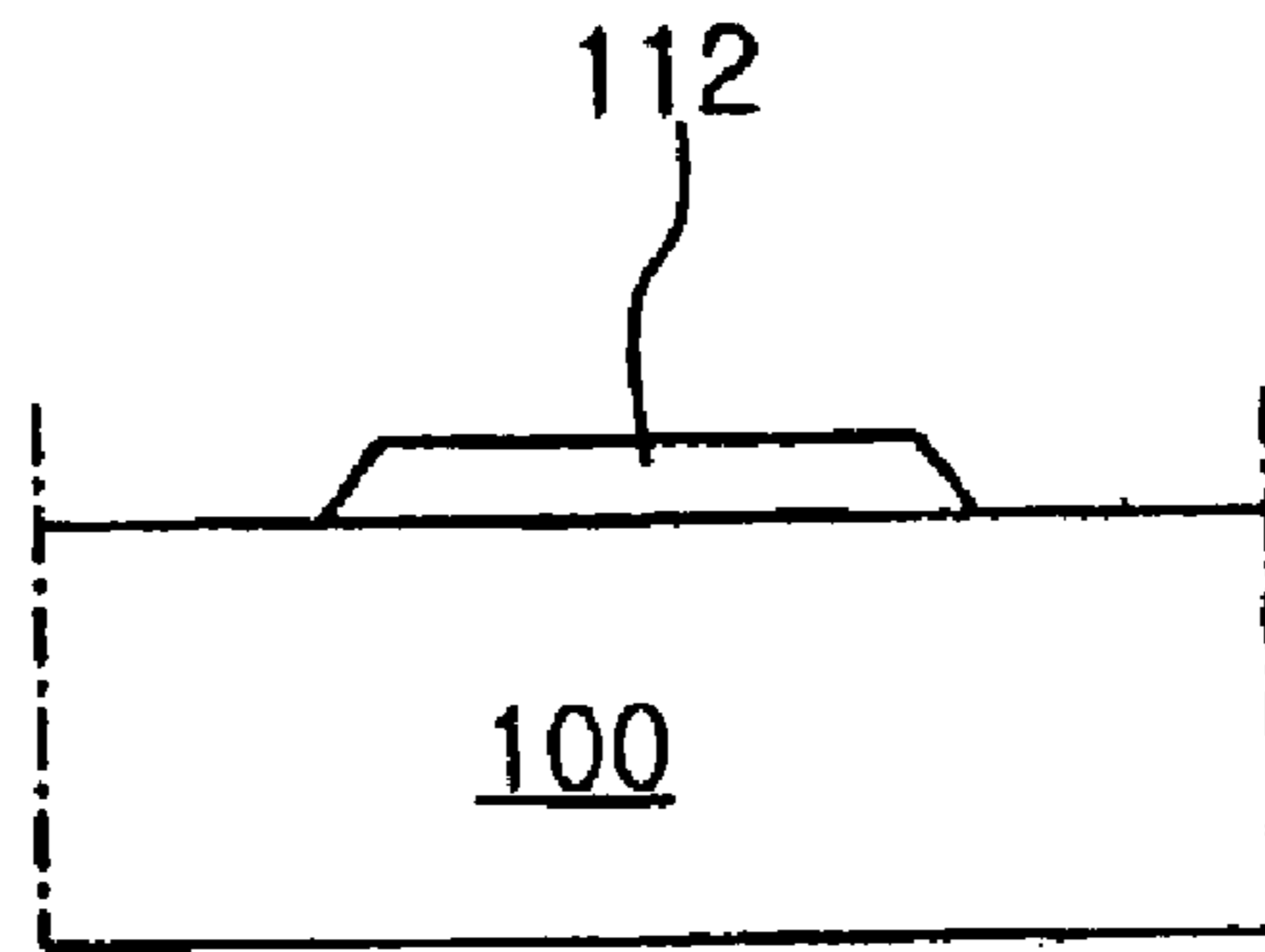

FIG. 6A

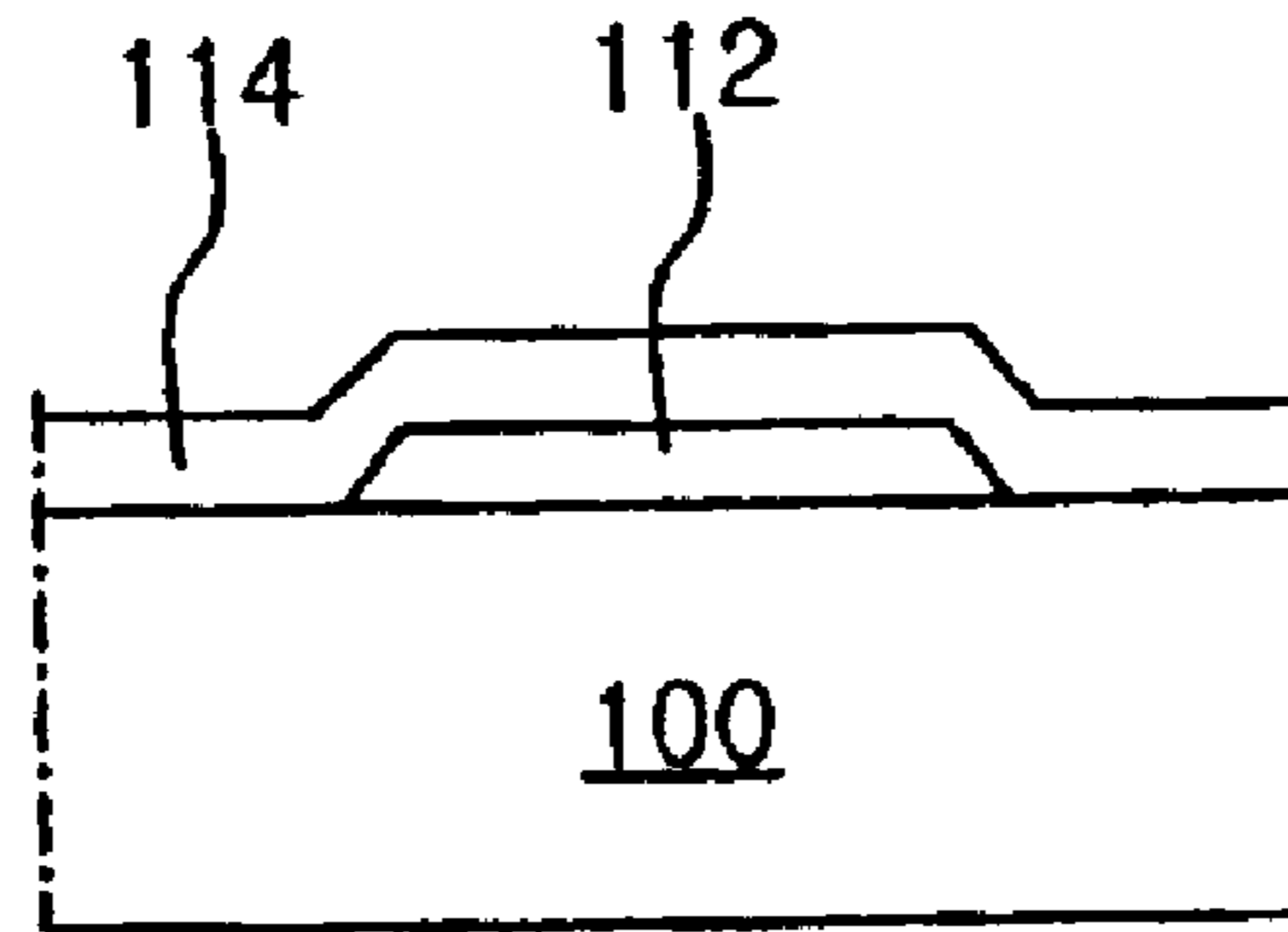

FIG. 6B

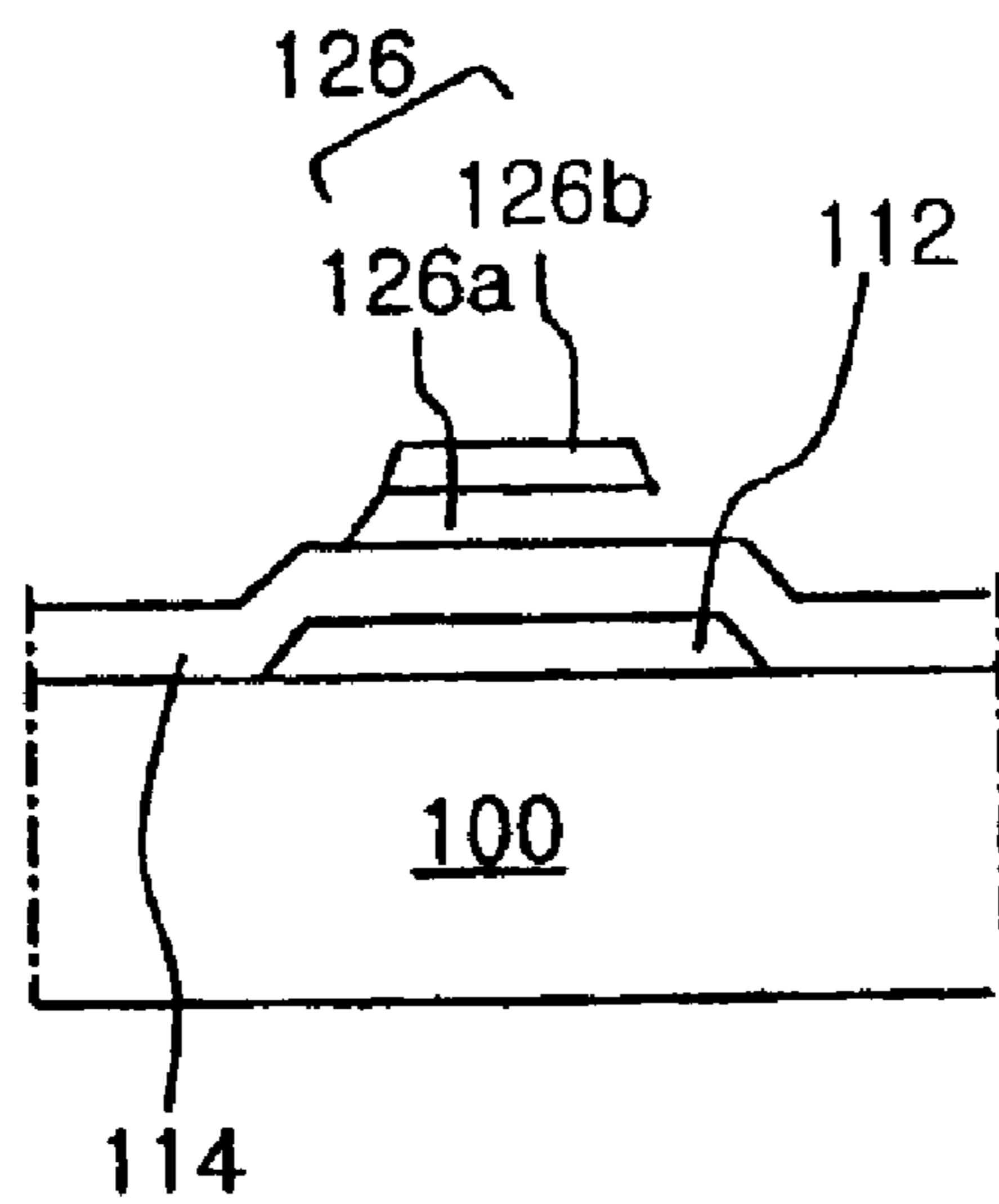

FIG. 6C

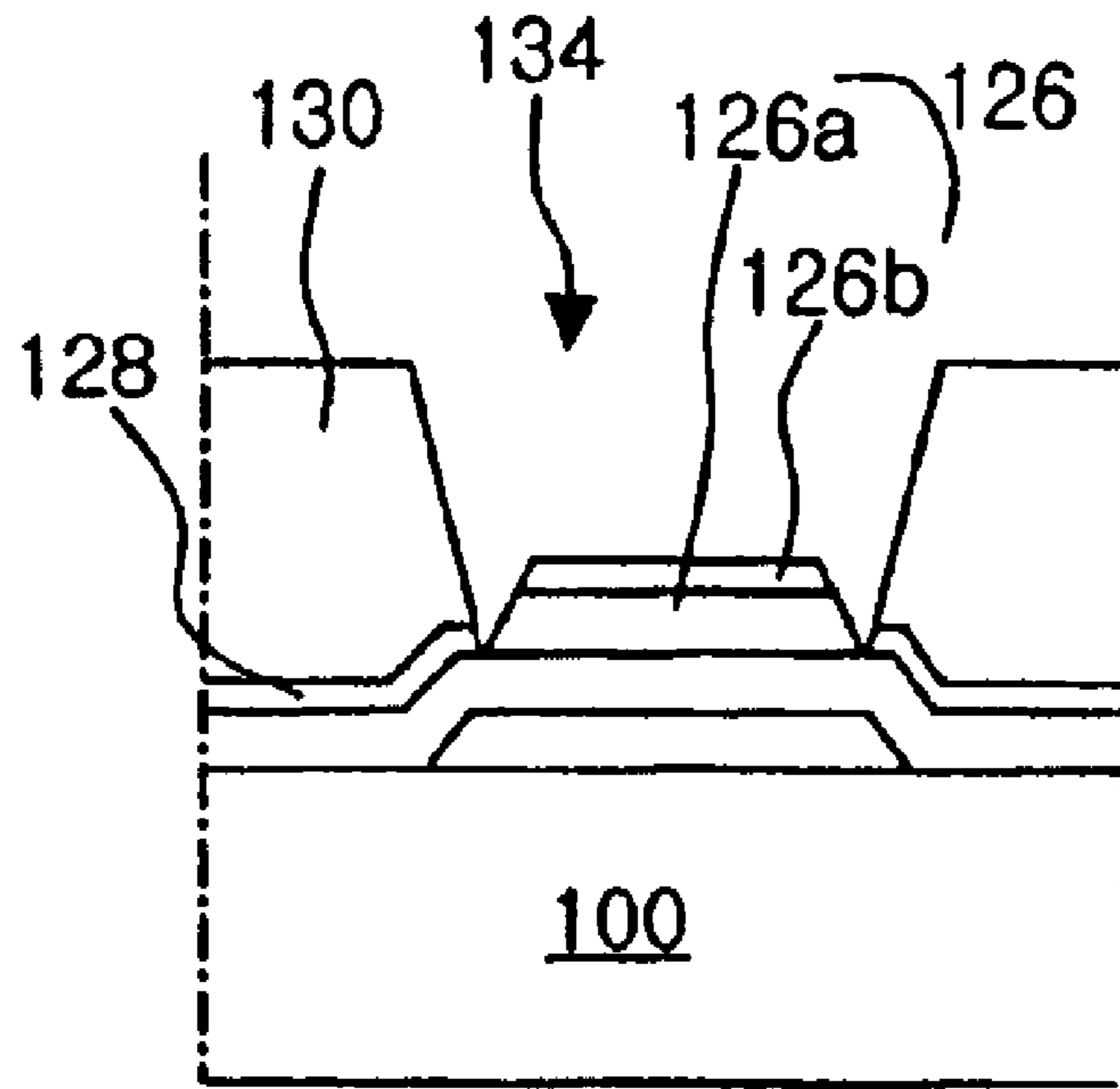

FIG. 6D

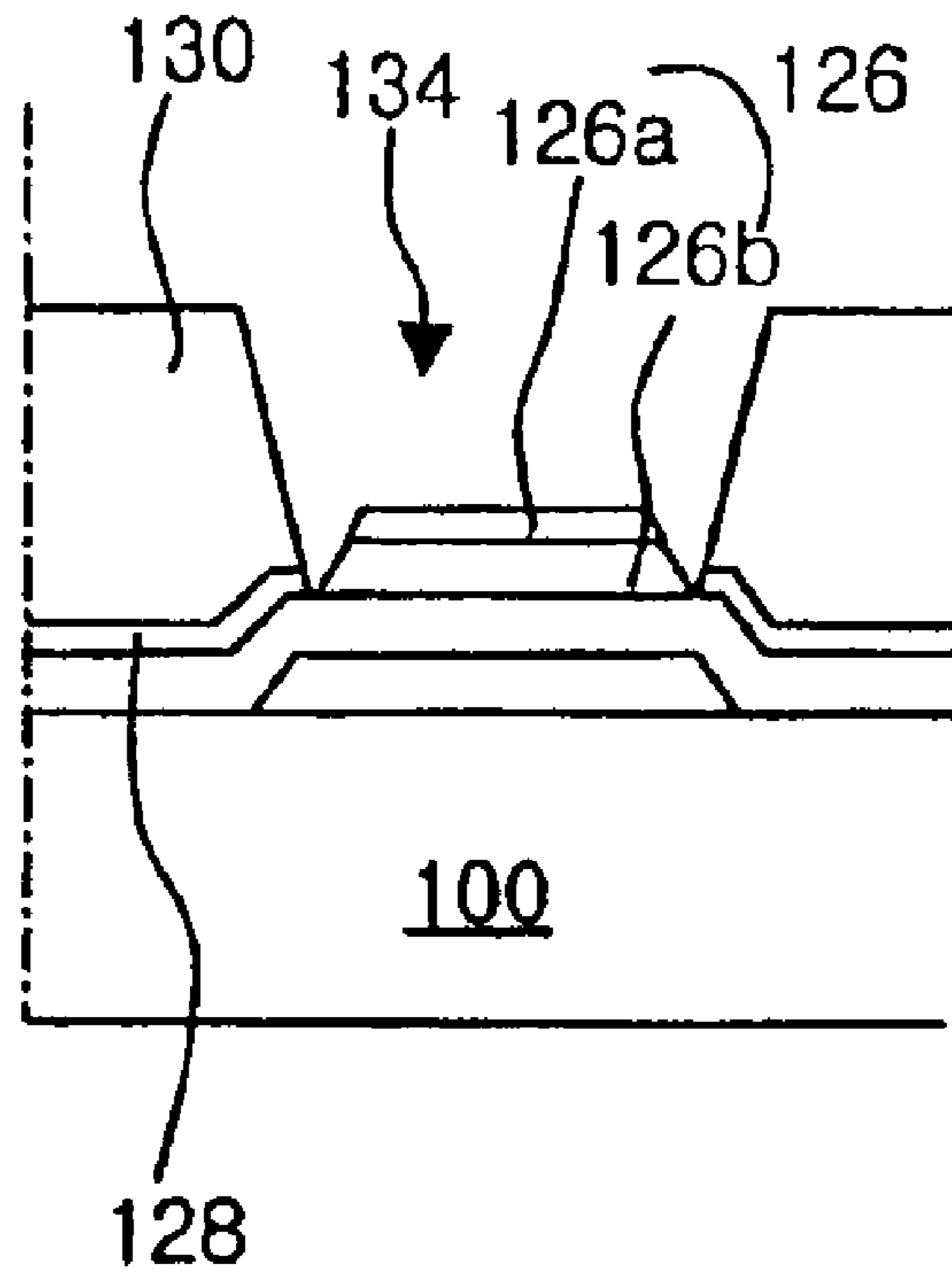

FIG. 6E

**TRANSFLECTIVE LIQUID CRYSTAL
DISPLAY DEVICE HAVING A REFLECTIVE
LAYER AT THE SAME LAYER AS SOURCE
AND DRAIN ELECTRODES**

This application is a divisional of prior application Ser. No. 10/607,203, filed Jun. 27, 2003 now U.S. Pat. No. 6,794,228.

BACKGROUND OF THE INVENTION

1. Field of the Invention

The present invention relates to a liquid crystal display device, and more particularly to a transfective liquid crystal display device and a fabricating method thereof by using a reduced number of masks.

2. Discussion of the Related Art

Liquid crystal display (LCD) devices are developed as next generation display devices because of their characteristics of light weight, thin profile, and low power consumption.

In general, an LCD device is a non-emissive display device that displays images utilizing optical anisotropy properties of liquid crystal materials that are interposed between a thin film transistor (TFT) array substrate and a color filter (C/F) substrate. Presently, among the various type of LCD devices commonly used, active matrix LCD (AM-LCD) devices in which thin film transistors (TFTs) are disposed in a matrix for each pixel region have been developed because of their high resolution and superiority in displaying moving images.

FIG. 1 is a schematic cross-sectional view of a liquid crystal display device according to the related art.

In FIG. 1, first and second substrates **2** and **4** are spaced apart and facing each other, and a liquid crystal layer **6** is interposed therebetween. A gate electrode **8** is formed on an inner surface of the second substrate **4** and a gate insulating layer **9** is formed on the gate electrode **8**. A semiconductor layer **11** including an active layer **11a** and an ohmic contact layer **11b** is formed on the gate insulating layer **9** over the gate electrode **8**. Source and drain electrodes **13** and **15** are formed on the semiconductor layer **11**. The source and drain electrodes **13** and **15** are spaced apart from each other, and the active layer **11a** corresponding to a space between the source and drain electrodes **13** and **15** functions as a channel "ch." The gate electrode **8**, the semiconductor layer **11**, and the source and drain electrodes **13** and **15** constitute a thin film transistor (TFT) "T." Even though not shown in FIG. 1, a gate line connected to the gate electrode **8** is formed along a first direction and a data line connected to the source electrode **13** is disposed along a second direction crossing the first direction. A pixel region "P" is defined by a cross of the gate line and the data line. A passivation layer **19** including a drain contact hole **17** is formed on the TFT "T" and a pixel electrode **21** connected to the drain electrode **15** through the drain contact hole **17** is formed in the pixel region "P."

A color filter layer **23** corresponding to the pixel electrode **21** is formed on an inner surface of the first substrate **2**. The color filter layer transmits only light of a specific wavelength. A black matrix **27** is formed at a border between the adjacent color filter layers **23** to prevent a light leakage and an inflow of ambient light into the TFT "T." A common electrode **29** is formed on the color filter layer **23** and the black matrix **27** to apply a voltage to the liquid crystal layer **6**. To prevent a leakage of the liquid crystal layer **6**, a

peripheral portion of the first and second substrates **2** and **4** is sealed with a seal pattern **31**. A spacer **33** is disposed between the first and second substrates **2** and **4** to keep a uniform cell gap with the seal pattern **31**. A first orientation film (not shown) can be formed between the common electrode **29** and the liquid crystal layer **6**, and a second orientation film (not shown) can be formed between the liquid crystal layer **6** and the pixel electrode **21** to induce an alignment of the liquid crystal layer **6**.

Even though not shown in FIG. 1, the LCD device includes a backlight unit under the second substrate **4** as a light source. However, the incident light from the backlight unit is attenuated during the transmission so that the actual transmittance is only about 7%. Accordingly, the backlight unit of the LCD device requires high brightness, thereby increasing power consumption by the backlight unit. Thus, a relatively heavy battery is required to supply a sufficient power to the backlight unit of such a device, and the battery cannot be used outdoors for a long period of time because of the increased power requirements.

In order to overcome the problems described above, a reflective LCD device and a transfective LCD device have been developed. The reflective LCD device uses the ambient light instead of light from the backlight unit, and thus it is light weight and easy to carry. In addition, power consumption of the reflective LCD device is reduced so that the reflective LCD device can be used for a portable display device such as an electronic diary or a personal digital assistant (PDA). In the reflective and transfective LCD devices, a reflective layer of a metallic material having a high reflectance is formed in a pixel region. The reflective layer can be formed in the pixel region over or under a transmissive electrode. More recently, the transmissive electrode is formed over the reflective layer to induce an alignment of the liquid crystal layer easily. Even with this structure, a transfective LCD having a multiple-layered insulating layer is suggested for protection of the reflective layer and to prevent an electrical short between the transmissive electrode and the reflective layer.

FIGS. 2A to 2G are schematic cross-sectional views showing a fabricating process of a display region of an array substrate for a transfective liquid crystal display device including a multiple-layered insulating layer according to the related art, and FIGS. 3A to 3G are schematic cross-sectional views showing a fabricating process of a non-display region of an array substrate for a transfective liquid crystal display device including a multiple-layered insulating layer according to the related art. Patterns on the array substrate are formed through a mask process including a deposition, a coating, a photolithography and an etching, and figures are shown according to a number of the mask process.

In FIGS. 2A and 3A, a gate electrode **10** and a first align key **12** of a first metallic material are formed on a substrate **4** through a first mask process.

In FIGS. 2B and 3B, after a gate insulating layer **14** of a first insulating material is formed on the gate electrode **10** and the first align key **12**, a semiconductor layer **16** including an active layer **16a** of amorphous silicon (a-Si) and an ohmic contact layer **16b** of impurity-doped amorphous silicon (n+ a-Si) is formed on the gate insulating layer **14** over the gate electrode **10** through a second mask process.

In FIGS. 2C and 3C, source and drain electrodes **18** and **22** of a second metallic material are formed on the semiconductor layer **16** through a third mask process. The source and drain electrodes **18** and **22** are spaced apart from each

other. At the same time, a data line **20** connected to the source electrode **18** is formed on the gate insulating layer **14**, and a second align key **24** is formed on the gate insulating layer **14** over the first align key **12**. The gate electrode **10**, the semiconductor layer **16**, and source and drain electrodes **18** and **22** constitute a thin film transistor (TFT) "T."

In FIGS. **2D** and **3D**, after first, second and third passivation layers **25**, **26** and **28** are sequentially formed on the TFT "T" and the second align key **24**, a first open portion **30** exposing the second align key **24** is formed in the first, second and third passivation layers **25**, **26** and **28** through a fourth mask process. The first open portion **30** is for preventing the second align key **24** from being screened by the relatively thick second passivation layer **26**. Thus, a mask for the fourth mask process can have a simpler structure than that of the previous first to third mask processes.

In FIGS. **2E** and **3E**, a reflective layer **32** of a third metallic material having a high reflectance is formed on the third passivation layer **28** over the TFT "T" through a fifth mask process. The reflective layer **32** has a second open portion **34** exposing the third passivation layer **28**. In this step of forming the reflective layer **32**, the second align key **24** is used for the fifth mask process. The first and third passivation layers **25** and **28** are made of silicon nitride (SiNx), and the second passivation layer **26** is made of benzocyclobutene (BCB). The first passivation layer **25** is formed to improve an electrical property of the TFT "T." The second passivation layer **26** is formed to reduce an electrical interference between the reflective layer **32** and a transmissive electrode (not shown). The third passivation layer **28** is formed to improve a contact property between the second passivation layer **26** and the reflective layer **32**.

In FIGS. **2F** and **3F**, after a fourth passivation layer **36** is formed on the reflective layer **32** and the second align key **24**, a drain contact hole **38** exposing the drain electrode **22** is formed in the first to fourth passivation layers **25**, **26**, **28** and **36** corresponding to the second open portion **34** through a sixth mask process. The fourth passivation layer **36** is made of the same material as the first and second passivation layers **25** and **28**. The fourth passivation layer **36** is formed to prevent the Galvanic phenomenon (a corrosion phenomenon) between the reflective layer **32** and the transmissive electrode (not shown).

In FIGS. **2G** and **3G**, a transmissive electrode **40** of a transparent conductive material is formed on the fourth passivation layer **36** in a pixel region "P" through a seventh mask process. The transmissive electrode **40** is connected to the drain electrode **22** through the drain contact hole **38**. The pixel region "P" includes a reflective portion corresponding to the reflective layer **32** and a transmissive portion. Images are displayed by using an ambient light in the reflective portion, while images are displayed by using light from the backlight unit (not shown) in the transmissive portion.

As shown in FIGS. **2A** to **2G** and FIGS. **3A** to **3G**, an array substrate for a transfective LCD device is formed through seven mask processes including a gate process, a semiconductor layer process, a data process, a reflective layer process, an align key open process, a contact hole process and a transmissive electrode process. Thus, the process of an array substrate for a transfective LCD device has more fabrication steps than that for a transmissive LCD device, and chemical and/or physical processes are repeated in the mask process. Therefore, as the fabrication steps increase, a fabrication cost and a possibility of damages to the device also increase.

SUMMARY OF THE INVENTION

Accordingly, the present invention is directed to a liquid crystal display device that substantially obviates one or more of the problems due to limitations and disadvantages of the related art.

An advantage of the present invention is to provide a transfective liquid crystal display device whose production yield is improved by reducing the number of mask processes.

An advantage of the present invention is to provide an array substrate for a transfective liquid crystal display device where source and drain electrodes has multiple layers of metallic material and an additional reflective layer is omitted.

Additional features and advantages of the invention will be set forth in the description which follows, and in part will be apparent from the description, or may be learned by practice of the invention. These and other advantages of the invention will be realized and attained by the structure particularly pointed out in the written description and claims hereof as well as the appended drawings.

To achieve these and other advantages and in accordance with the purpose of the present invention, as embodied and broadly described, an array substrate for a transfective liquid crystal display device may, for example, include a gate line on a substrate; a data line crossing the gate line, the gate line and the data line defining a pixel region having a transmissive portion and a reflective portion; a gate electrode connected to the gate line; source and drain electrode spaced apart from each other over the gate electrode, the source electrode being connected to the data line; a reflective layer having the same layer as the source and drain electrodes, the reflective layer being disposed in the pixel region and having a transmissive hole corresponding to the transmissive portion; and a pixel electrode connected to the drain electrode, the pixel electrode being disposed in the pixel region, wherein the source and drain electrodes and the reflective layer have multiple layers of metal, wherein a top layer of the multiple layers includes a reflective metallic material.

In another aspect of the present invention, a method of fabricating an array substrate for a transfective liquid crystal display device may, for example, include forming a gate electrode and a gate line on a substrate through a first mask process; forming a first insulating layer on the gate electrode and the gate line; forming a semiconductor layer on the first insulating layer over the gate electrode through a second mask process; forming source and drain electrodes on the semiconductor layer, a data line crossing the gate line, and a reflective layer on the first insulating layer through a third mask process, the source and drain electrodes being spaced apart from each other, the source electrode being connected to the data line, the gate line and the data line defining a pixel region having a transmissive portion and a reflective portion, the reflective layer being disposed in the pixel region and having a transmissive hole corresponding to the transmissive portion, the source and drain electrodes, the data line and the reflective layer having multiple layers of metal, a top layer of the multiple layers including a reflective metallic material; forming second insulating layer on the source and drain electrodes, the data line and the reflective layer through a fourth mask process, the second insulating layer having a drain contact hole exposing the drain electrode; and forming a pixel electrode on the third insulating layer through a fifth mask process, the pixel electrode including a transparent conductive material, the pixel electrode being connected to the drain electrode through the drain contact hole.

In yet another aspect of the present invention, a method of fabricating an array substrate for a transfective liquid crystal display device may, for example, include forming a gate electrode and a gate line on a substrate; forming a first

insulating layer on the gate electrode and the gate line; forming a semiconductor layer on the first insulating layer, the semiconductor layer having an active layer and an ohmic contact layer; forming source and drain electrodes, a data line and a reflective layer having multiple layers on the first insulating layer at the same time, wherein the gate line and the data line defines a pixel region having a transmissive portion and a reflective portion, forming a pixel electrode of a transparent conductive material electrically connected to the drain electrode.

It is to be understood that both the foregoing general description and the following detailed description are exemplary and explanatory and are intended to provide further explanation of the invention as claimed.

BRIEF DESCRIPTION OF THE DRAWINGS

The accompanying drawings, which are included to provide a further understanding of the invention and are incorporated in and constitute a part of this specification, illustrate embodiments of the invention and together with the description serve to explain the principles of the invention.

In the drawings:

FIG. 1 is a schematic cross-sectional view of a liquid crystal display device according to the related art;

FIGS. 2A to 2G are schematic cross-sectional views showing a fabricating process of a display region of an array substrate for a transmissive liquid crystal display device including a multiple-layered insulating layer according to the related art;

FIGS. 3A to 3G are schematic cross-sectional views showing a fabricating process of a non-display region of an array substrate for a transmissive liquid crystal display device including a multiple-layered insulating layer according to the related art;

FIG. 4 is a schematic plane view of a liquid crystal display device according to an embodiment of the present invention;

FIGS. 5A to 5E are schematic cross-sectional views showing a fabricating process of a display region of an array substrate for a transmissive liquid crystal display device according to an embodiment of the present invention; and

FIGS. 6A to 6E are schematic cross-sectional views showing a fabricating process of a non-display region of an array substrate for a transmissive liquid crystal display device according to an embodiment of the present invention.

DETAILED DESCRIPTION OF THE ILLUSTRATED EMBODIMENTS

Reference will now be made in detail to embodiments of the present invention, example of which is illustrated in the accompanying drawings. Wherever possible, similar reference numbers will be used throughout the drawings to refer to the same or like parts.

FIG. 4 is a schematic plane view of a liquid crystal display device according to an embodiment of the present invention.

In FIG. 4, a gate line 111 and a data line 120 are formed to cross each other and define a pixel region "P." A gate electrode 110 extends from the gate line 111. A semiconductor layer 116 is formed over the gate electrode 110. Source and drain electrodes 118 and 122 are spaced apart from each other and overlap the gate electrode 110 and the semiconductor layer 116. The source electrode 118 extends from the data line 120. The gate electrode 110, the semiconductor layer 116 and the source and drain electrodes 118 and 122 constitute a thin film transistor (TFT) "T." A

reflective layer 124 having a transmissive hole 123 is formed in the pixel region "P" at the same layer as the data line 120. A pixel electrode 136 connected to the drain electrode 122 through a drain contact hole 132 is formed in the pixel region "P." The pixel region "P" includes a transmissive portion corresponding to the transmissive hole 123 and a reflective portion corresponding to the reflective layer 124. The data line 120, and the source and drain electrodes 118 and 122 have multiple layers whose top layer is made of a metallic material having a high reflectance. Accordingly, the reflective layer 124 can be simultaneously formed with the data line 120, and the source and drain electrodes 118 and 122, which results in a reduced number of the mask processes.

Since the data line 120 has the same layer as the reflective layer 124, the data line 120 and the reflective layer 124 are spaced apart from each other by a distance of about 5 μm to about 7 μm to prevent an electrical short therebetween. Moreover, a first capacitor electrode 113 extends from the gate line 111 and a second capacitor electrode 121 is formed over the first capacitor electrode 113. The second capacitor electrode 121 may be formed at the same layer as the data line 120, and a first insulating layer (not shown) is interposed between the first and second capacitor electrodes 113 and 121. The pixel electrode 136 is connected to the second capacitor electrode through a capacitor contact hole 125 in a second insulating layer (not shown). Accordingly, the first and second capacitor electrodes 113 and 121, and the first insulating layer constitute a storage capacitor "C_{ST}" connected to the TFT "T."

FIGS. 5A to 5G are schematic cross-sectional views showing a fabricating process of a display region of an array substrate for a transmissive liquid crystal display device according to an embodiment of the present invention, and FIGS. 6A to 6G are schematic cross-sectional views showing a fabricating process of a non-display region of an array substrate for a transmissive liquid crystal display device according to an embodiment of the present invention.

In FIGS. 5A and 6A, a gate electrode 110 and a first align key 112 of a first metallic material are formed on a substrate 100 through a first mask process.

In FIGS. 5B and 6B, after a gate insulating layer 114 of a first insulating material is formed on the gate electrode 110 and the first align key 112, a semiconductor layer 116 including an active layer 116a of amorphous silicon (a-Si) and an ohmic contact layer 116b of impurity-doped amorphous silicon (n+a-Si) is formed on the gate insulating layer 114 over the gate electrode 110 through a second mask process. The first insulating material can be made of a silicon insulating material such as silicon nitride (SiN_x).

In FIGS. 5C and 6C, source and drain electrodes 118 and 122 of a second metallic material are formed on the semiconductor layer 116 through a third mask process. The source and drain electrodes 118 and 122 are spaced apart from each other. At the same time, a data line 120 connected to the source electrode 118, a reflective layer 124 and a second align key 126 are formed on the gate insulating layer 114. Thus, the data line 120, the reflective layer 124 and the second align key 126 have the same layer as the source and drain electrodes 118 and 122. The reflective layer 124 is disposed in the pixel region "P" and the second align key 126 corresponds to the first align key 112. The gate electrode 110, the semiconductor layer 116, and source and drain electrodes 118 and 122 constitute a thin film transistor (TFT) "T."

The data line 120 can have multiple layers in which a top layer includes a metallic material having a high reflectance,

and a bottom layer includes a metallic material having a high chemical corrosion resistance. For example, the top layer can include one of aluminum (Al) and aluminum (Al) alloy such as aluminum neodymium (AlNd) and the bottom layer can include one of molybdenum (Mo), tungsten (W), nickel (Ni) and titanium (Ti). Therefore, the source electrode **118** includes first and second sub-source electrodes **118a** and **118b**. Similarly, the drain electrode **122** includes first and second sub-drain electrodes **122a** and **122b**, the data line **120** includes first and second sub-data lines **120a** and **120b**, the reflective layer **124** includes first and second sub-reflective layers **124a** and **124b**, and the second align key **126** includes first and second sub-second align keys **126a** and **126b**. Since the second sub-reflective layer **124b** is made of a metallic material having a high reflectance, the reflective layer **124** can be simultaneously formed with the source and drain electrodes **118** and **122** and the data line **120** through the third mask process.

In FIGS. **5D** and **6D**, after first and second passivation layers **128** and **130** are sequentially formed on the TFT “T” and the second align key **126**, a drain contact hole **132** exposing the drain electrode **122** and an open portion **134** exposing the second align key **126** are formed in the first and second passivation layers **128** and **130** through a fourth mask process. The first passivation layer **128** includes one of an inorganic insulating material group and the second passivation layer **130** includes one of an organic insulating material group having a low dielectric constant. For example, the first and second passivation layers **128** and **130** can be made of a silicon insulating material and benzocyclobutene (BCB), respectively. The open portion is formed through an additional mask process in the related art. In this embodiment, however, since the reflective layer **124** is simultaneously formed with the source and drain electrodes **118** and **122** through the third mask process, the open portion **134** can be formed through the fourth mask process of forming the drain contact hole **132**. Accordingly, the additional mask process of forming the open portion can be omitted.

In FIGS. **5E** and **6E**, a pixel electrode **136** of a transparent conductive material is formed on the second passivation layer **130** in a pixel region “P” through a fifth mask process. The pixel electrode **136** is connected to the drain electrode **122** through the drain contact hole **132**. The pixel region “P” includes a reflective portion corresponding to the reflective layer **124** and a transmissive portion corresponding to the transmissive hole **123**. Images are displayed by using an ambient light in the reflective portion, while images are displayed by using light from the backlight unit (not shown) in the transmissive portion.

Consequently, since a reflective layer, a data line, source and drain electrodes and an align key are simultaneously formed to have multiple layers whose top layer includes a metallic material having a high reflectance, an additional mask process for the align key can be eliminated. Therefore, a high production yield and a low production cost can be obtained.

It will be apparent to those skilled in the art that various modifications and variations can be made in the present

invention without departing from the spirit or scope of the invention. Thus, it is intended that the present invention cover the modifications and variations of this invention provided they come within the scope of the appended claims and their equivalents.

What is claimed is:

1. An array substrate for a transfective liquid crystal display device, comprising:

a gate line on a substrate;

a data line crossing the gate line, the gate line and the data line defining a pixel region having a transmissive portion and a reflective portion;

a gate electrode connected to the gate line;

source and drain electrode spaced apart from each other over the gate electrode, the source electrode being connected to the data line;

a reflective layer at the same layer as the source and drain electrodes, the reflective layer being disposed in the pixel region and having a transmissive hole corresponding to the transmissive portion; and

a pixel electrode connected to the drain electrode, the pixel electrode being disposed in the pixel region,

wherein the source and drain electrodes and the reflective layer have multiple layers of metal,

wherein a top layer of the multiple layers includes a reflective metallic material.

2. The array substrate according to claim **1**, wherein the reflective metallic material is a metal including aluminum (Al).

3. The array substrate according to claim **2**, wherein the metal is aluminum-neodymium (AlNd).

4. The array substrate according to claim **1**, wherein the data line and the reflective layer are spaced apart from each other by a distance of about $5\ \mu\text{m}$ to about $7\ \mu\text{m}$.

5. The array substrate according to claim **1**, further comprising first to third insulating layers and a semiconductor layer, wherein the first insulating layer is formed on the gate electrode and the gate line, wherein the semiconductor layer is formed on the first insulating layer, wherein the second and third insulating layers are sequentially formed on the source and drain electrodes and the reflective layer, and wherein the second and third insulating layers have a drain contact hole exposing the drain electrode.

6. The array substrate according to claim **5**, further comprising first and second capacitor electrodes, wherein the first capacitor electrode has the same layer as the gate line, wherein the second capacitor electrode has the same layer as the data line, wherein the second capacitor electrode overlaps the first capacitor electrode.

7. The array substrate according to claim **6**, wherein the first insulating layer is interposed between the first and second capacitor electrodes, wherein the second capacitor electrode is connected to the pixel electrode through a capacitor contact hole in the second and third insulating layers.

* * * * *