



US006904668B2

(12) **United States Patent**
Dallmeyer et al.

(10) **Patent No.:** **US 6,904,668 B2**
(45) **Date of Patent:** **Jun. 14, 2005**

(54) **METHOD OF MANUFACTURING A
MODULAR FUEL INJECTOR**

5,038,738 A 8/1991 Hafner et al. 123/470
5,054,691 A 10/1991 Huang et al. 239/585
5,058,554 A 10/1991 Takeda et al. 123/456

(75) Inventors: **Michael P. Dallmeyer**, Newport News,
VA (US); **Robert MacFarland**,
Newport News, VA (US); **Michael J.
Hornby**, Williamsburg, VA (US)

(Continued)

(73) Assignee: **Siemens VDO Automotive Corp.**,
Auburn Hills, MI (US)

FOREIGN PATENT DOCUMENTS

DE 197 24 075 12/1998
EP 0 781 917 7/1997
EP 1 219 815 7/2002
EP 1 219 820 7/2002
WO WO 98/05861 2/1998

(*) Notice: Subject to any disclaimer, the term of this
patent is extended or adjusted under 35
U.S.C. 154(b) by 378 days.

(Continued)

OTHER PUBLICATIONS

(21) Appl. No.: **09/820,672**

EP Application No. 02 07 6275; European Search Report;
Aug. 2, 2002.

(22) Filed: **Mar. 30, 2001**

(Continued)

(65) **Prior Publication Data**

US 2002/0138983 A1 Oct. 3, 2002

Primary Examiner—Paul D Kim

(51) **Int. Cl.**⁷ **H01F 7/06**

(57) **ABSTRACT**

(52) **U.S. Cl.** **29/602.1; 29/592.1; 29/890.01;**
29/890.1; 29/890.124; 123/319; 219/121.64;
239/533.2; 239/585.5; 239/600; 239/585.1

A method of fabricating a modular fuel injector permits the
fabrication of the electrical group subassembly outside a
clean room while a fuel group subassembly is fabricated
inside a clean room. The fuel injector comprises a valve
group subassembly and a coil group subassembly. The valve
group subassembly includes a tube assembly having a
longitudinal axis that extends between a first end and a
second end; a seat that is secured at the second end of the
tube assembly and that defines an opening; an armature
assembly that is disposed within the tube assembly; a
member that biases the armature assembly toward the seat;
an adjusting tube that is disposed in the tube assembly and
that engages the member for adjusting a biasing force of the
member; a filter that is located at least within the tube
assembly; and a first attachment portion. The coil group
subassembly includes a solenoid coil that is operable to
displace the armature assembly with respect to the seat; and
a second attachment portion that is fixedly connected to the
first attachment portion.

(58) **Field of Search** **29/592.1, 602.1,**
29/809.01, 809.02, 890.124; 239/533.2,
585.1, 585.5, 600; 219/121.64; 123/319

(56) **References Cited**

U.S. PATENT DOCUMENTS

3,567,135 A 3/1971 Gebert 239/585
4,342,427 A 8/1982 Gray 239/585
4,520,962 A 6/1985 Momono et al. 239/585
4,552,312 A 11/1985 Ohno et al. 239/585
4,597,558 A 7/1986 Hafner et al. 251/129.15
4,662,567 A 5/1987 Knapp 239/585
4,875,658 A 10/1989 Asai
4,915,350 A 4/1990 Babitzka et al. 251/129.15
4,944,486 A 7/1990 Babitzka 251/129.21
4,946,107 A 8/1990 Hunt 239/585
4,984,744 A 1/1991 Babitzka et al. 239/585
4,991,557 A 2/1991 DeGrace et al. 123/470

25 Claims, 16 Drawing Sheets

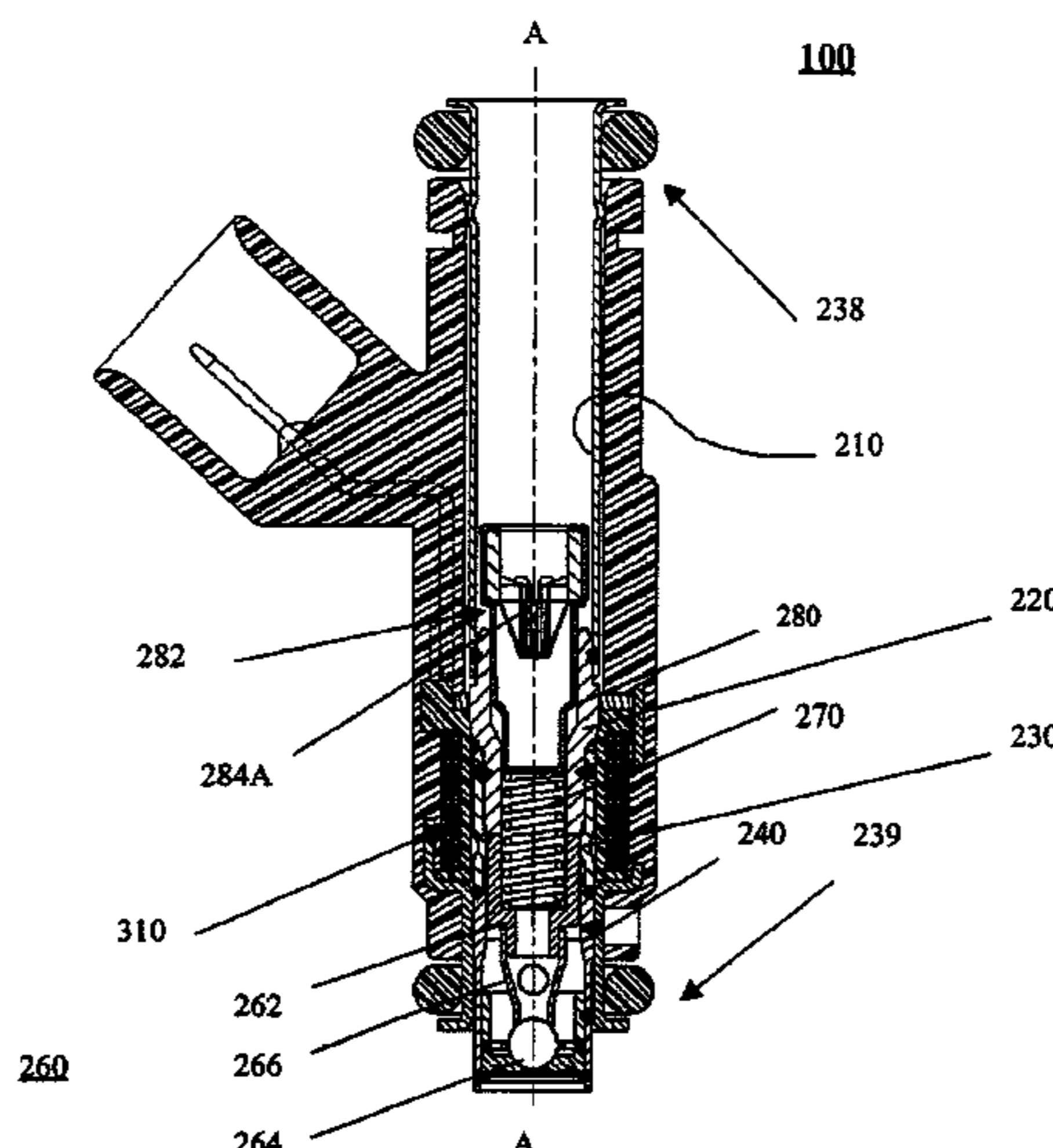

U.S. PATENT DOCUMENTS

5,076,499 A 12/1991 Cranford 239/585
 5,127,585 A 7/1992 Mesenich 239/585.5
 5,167,213 A 12/1992 Bassler et al. 123/470
 5,190,221 A 3/1993 Reiter 239/463
 5,211,341 A 5/1993 Wieczorek 239/585.3
 5,236,174 A 8/1993 Vogt et al. 251/129.21
 5,263,648 A 11/1993 Vogt et al. 239/585.4
 5,275,341 A 1/1994 Romann et al. 239/585.4
 5,340,032 A 8/1994 Stegmaier et al. 239/575
 5,462,231 A 10/1995 Hall 239/585.4
 5,494,224 A 2/1996 Hall et al. 239/585.5
 5,494,225 A 2/1996 Nally et al. 239/585.5
 5,520,151 A 5/1996 Gras et al. 123/470
 5,544,816 A 8/1996 Nally et al. 239/585.5
 5,566,920 A 10/1996 Romann et al. 251/129.21
 5,580,001 A 12/1996 Romann et al. 239/585.4
 5,678,767 A * 10/1997 Rahbar 239/533.2
 5,692,723 A 12/1997 Baxter et al. 251/129.21
 5,718,387 A 2/1998 Awarzamani et al. 239/585.1
 5,732,888 A 3/1998 Maier et al. 239/585.1
 5,755,386 A 5/1998 Lavan et al. 239/585.4
 5,769,391 A 6/1998 Noller et al. 259/129.21
 5,769,965 A 6/1998 Liedtke et al. 148/121
 5,775,355 A 7/1998 Maier et al. 137/15
 5,775,600 A 7/1998 Wildeson et al. 239/585.4
 5,875,975 A 3/1999 Reiter et al. 239/585.1
 5,901,688 A 5/1999 Balsdon et al. 123/516
 5,915,626 A 6/1999 Awarzamani et al. 239/135
 5,927,613 A 7/1999 Koyanagi et al. 239/585.1
 5,937,887 A 8/1999 Baxter et al. 137/15
 5,944,262 A 8/1999 Akutagawa et al. 239/585.4
 5,975,436 A 11/1999 Reiter et al. 239/585.1
 5,979,411 A 11/1999 Ricco 123/469
 5,979,866 A 11/1999 Baxter et al. 251/129.21
 5,996,227 A 12/1999 Reiter et al. 29/888.45
 5,996,910 A 12/1999 Takeda et al. 239/585.1
 5,996,911 A 12/1999 Gesk et al. 239/585.1
 6,003,790 A 12/1999 Fly 239/533.9

6,012,655 A 1/2000 Maier et al. 239/585.4
 6,019,128 A 2/2000 Reiter 137/549
 6,027,049 A 2/2000 Stier 239/585.1
 6,039,271 A 3/2000 Reiter 239/585.4
 6,039,272 A 3/2000 Ren et al. 239/597
 6,045,116 A 4/2000 Willke et al. 251/129.21
 6,047,907 A 4/2000 Hornby 239/585.1
 6,076,802 A 6/2000 Maier 251/129.21
 6,079,642 A 6/2000 Maier 239/585.1
 6,089,467 A 7/2000 Fochtman et al. 239/5
 6,089,475 A 7/2000 Reiter et al. 239/585.1
 6,168,098 B1 * 1/2001 Brinn, Jr. 239/585.4
 6,186,421 B1 * 2/2001 Wahba et al. 239/585.1
 6,186,472 B1 2/2001 Reiter 251/129.21
 6,201,461 B1 3/2001 Eichendorf et al. 335/256
 6,264,112 B1 * 7/2001 Landschoot et al. 239/5
 6,328,232 B1 12/2001 Haltiner, Jr. et al. 239/585.1
 6,454,192 B2 * 9/2002 Perry 239/585.1
 6,499,668 B2 * 12/2002 Dallmeyer et al. 239/5
 6,550,690 B2 * 4/2003 Dallmeyer et al. 239/5
 2001/0017327 A1 8/2001 Fochtman 239/585.4
 2001/0048091 A1 12/2001 Enomoto et al. 251/129.15

FOREIGN PATENT DOCUMENTS

WO WO 98/15733 4/1998
 WO WO 99/66196 12/1999
 WO WO 00/06893 2/2000 F02M/5/06
 WO WO 00/43666 7/2000

OTHER PUBLICATIONS

EP Application No. 02 07 6273; European Search Report; Aug. 1, 2002.
 EP Application No. 02 07 6274; European Search Report; Jul. 31, 2002.
 EP Application No. 02 07 5284; European Search Report; Jul. 25, 2002.

* cited by examiner

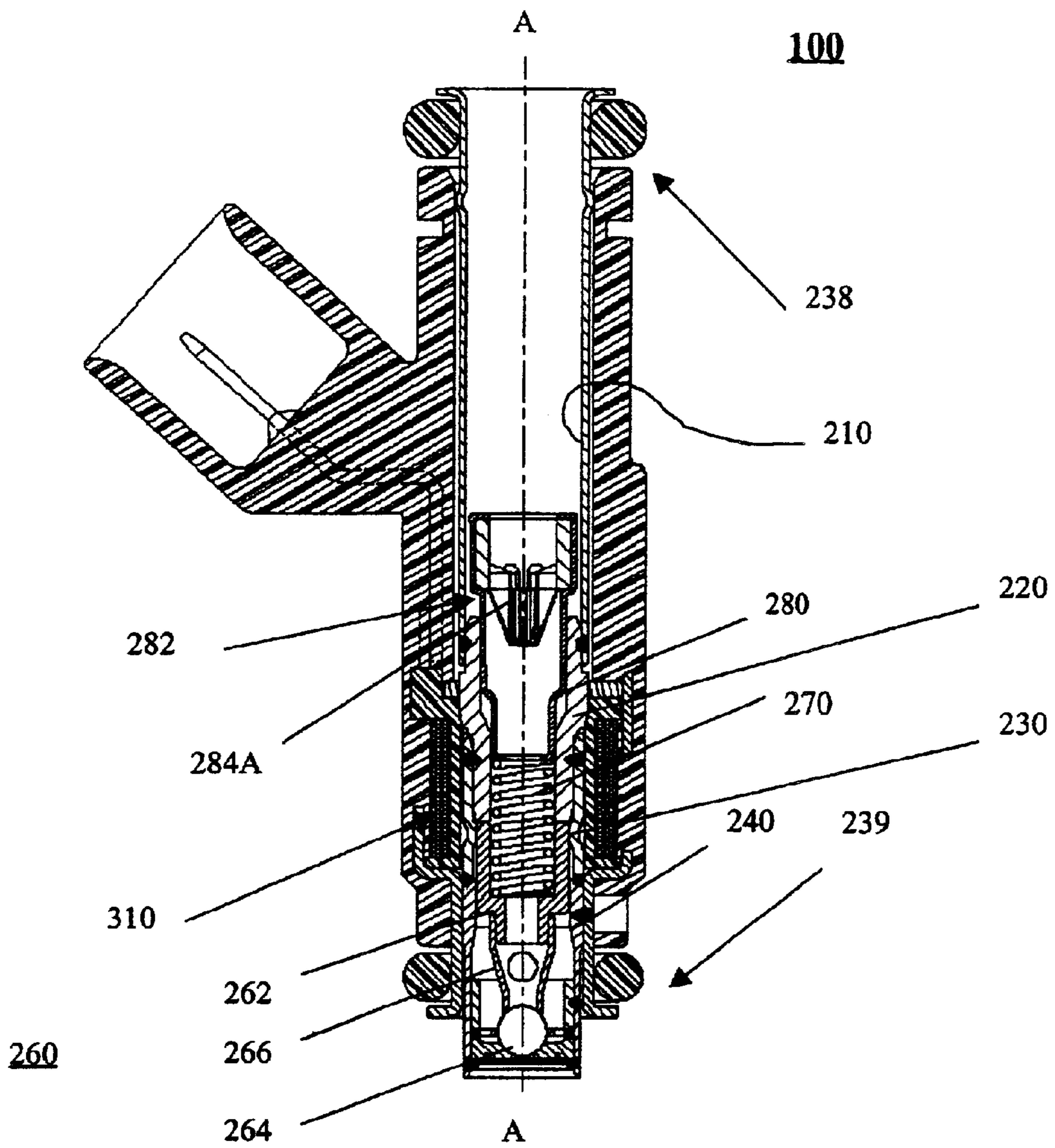

FIG. 1

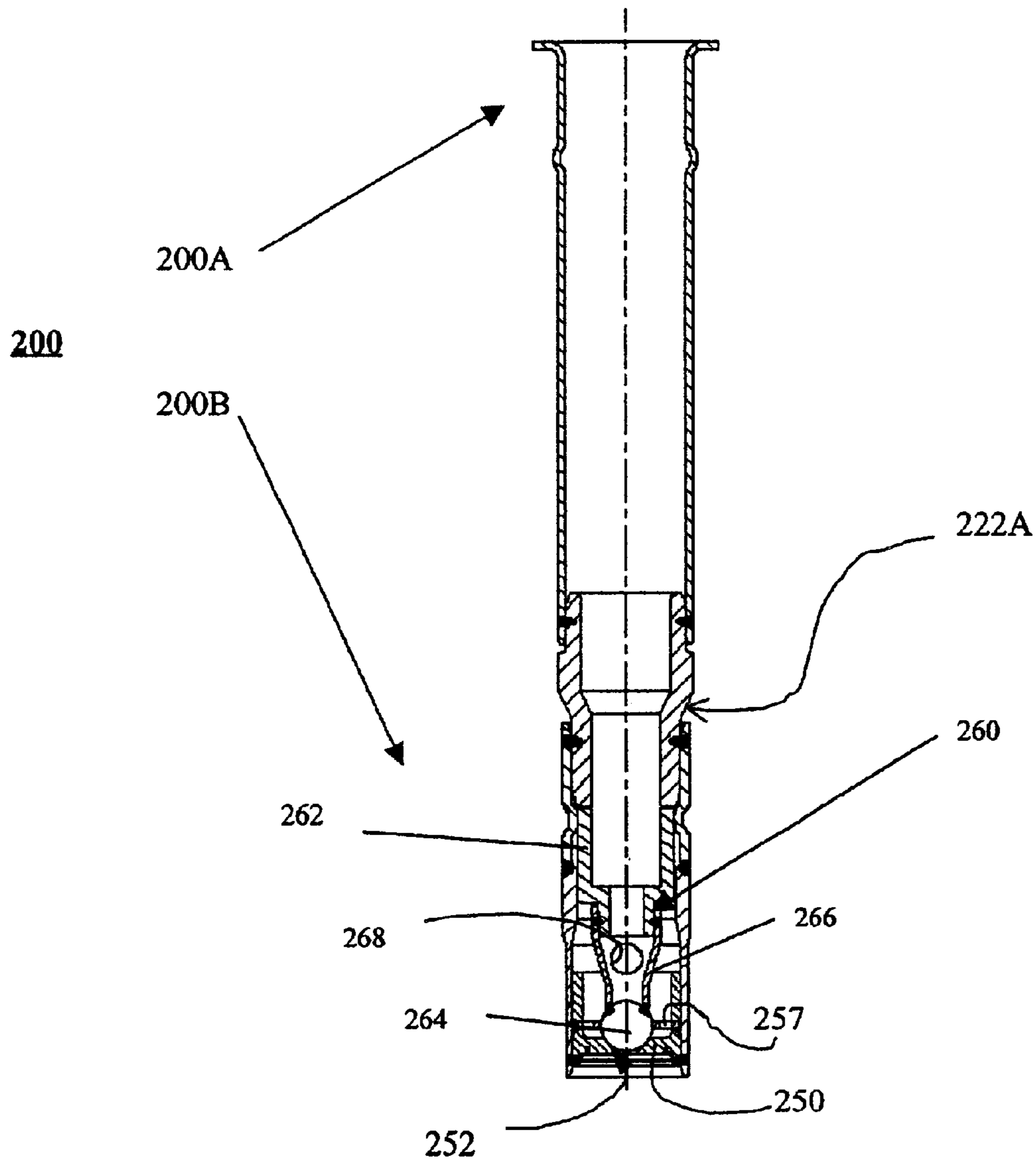

FIG. 2

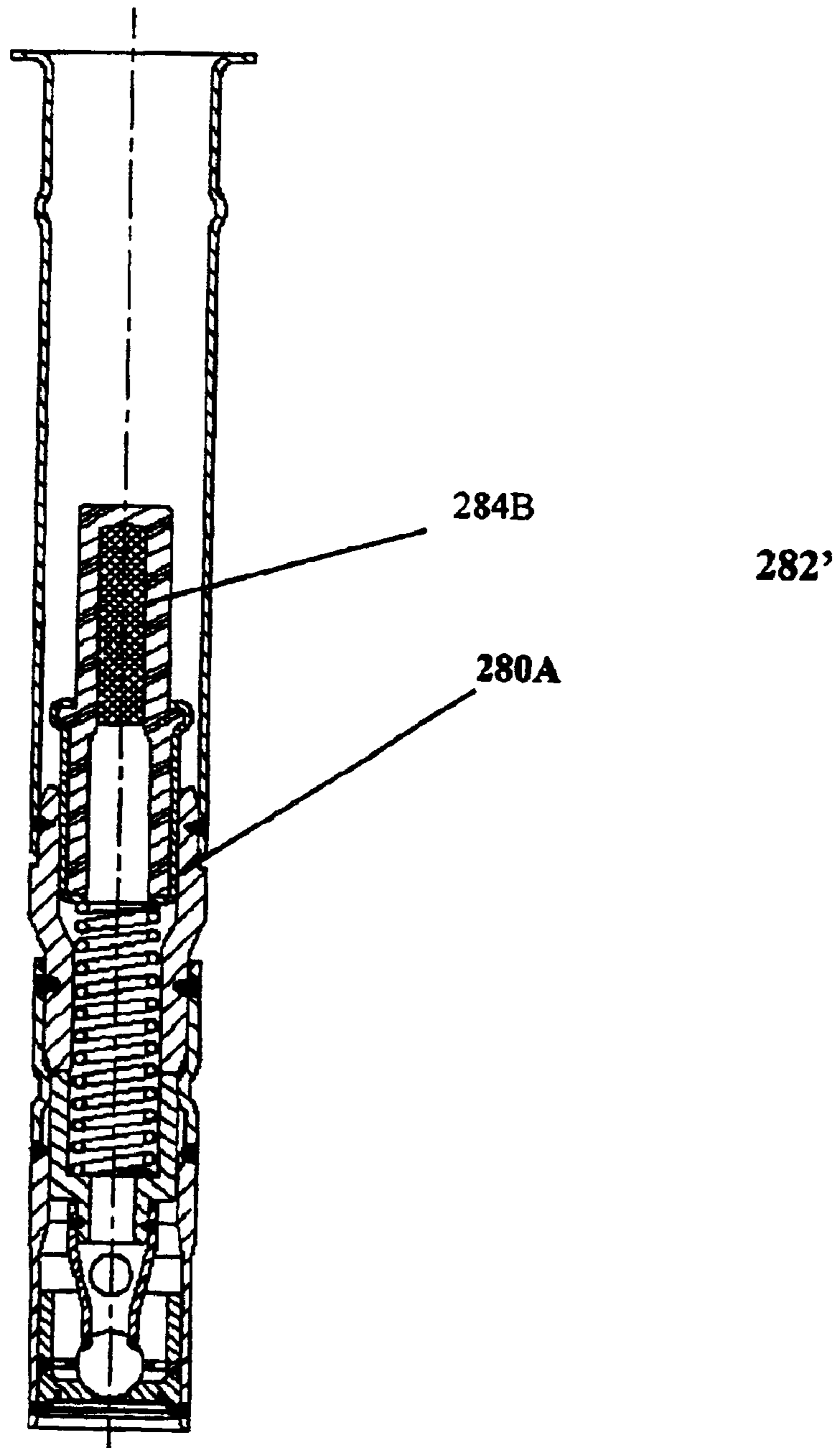
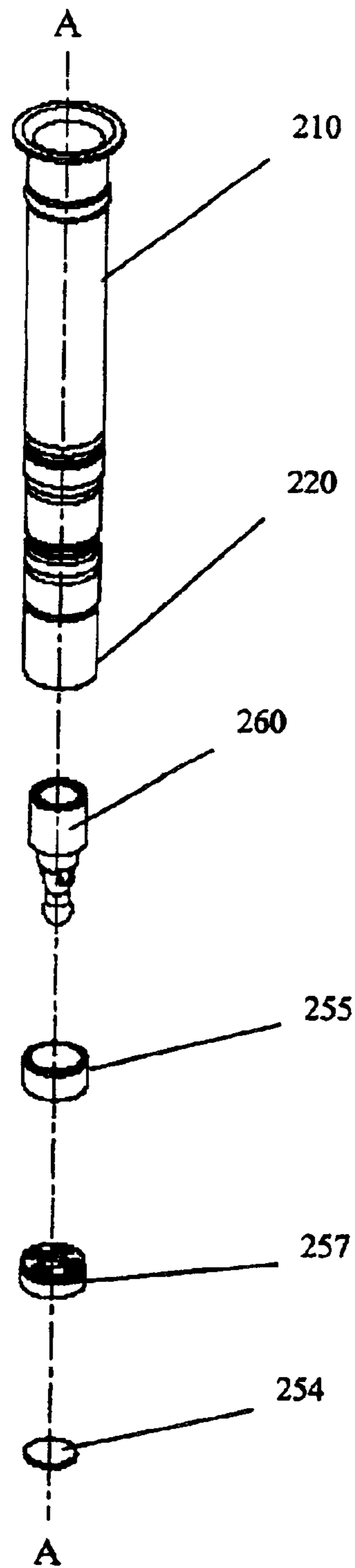

FIG. 2A



200

FIG. 2B

200

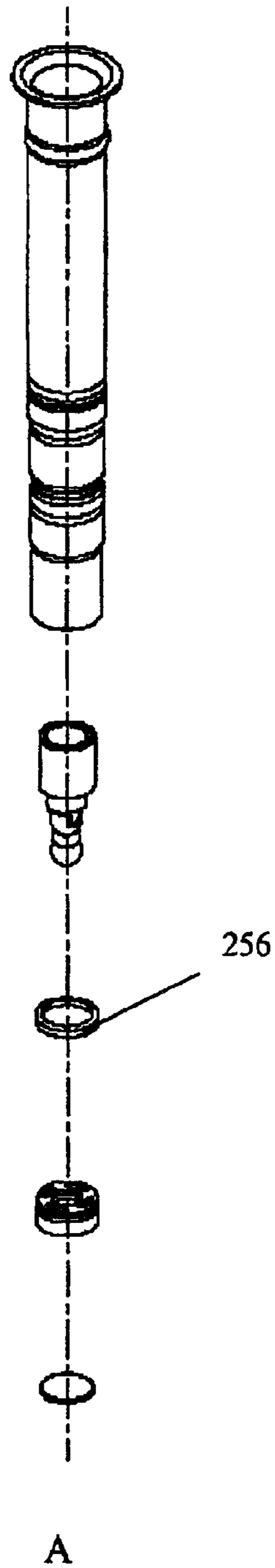

FIG. 2C

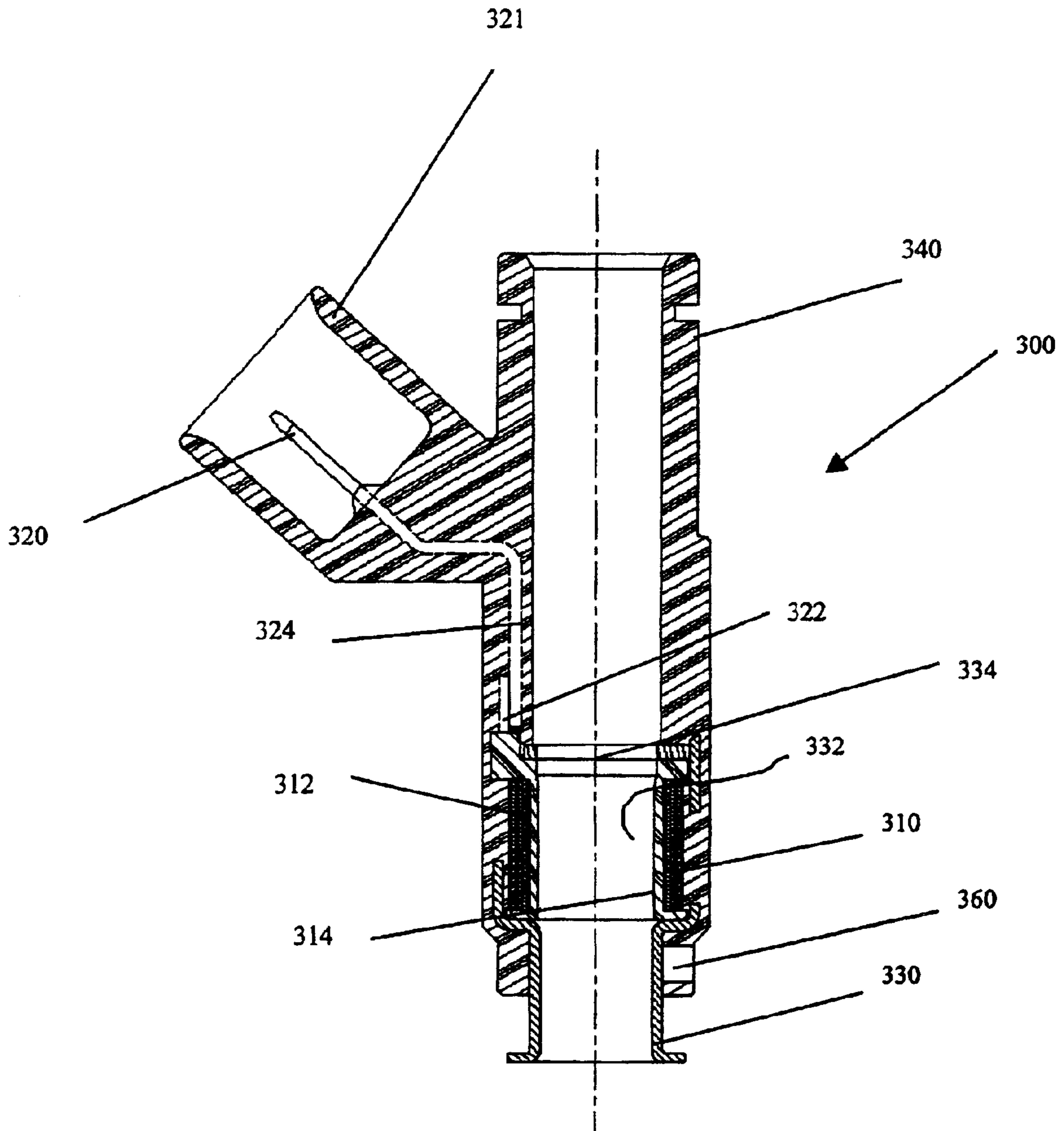

FIG. 3

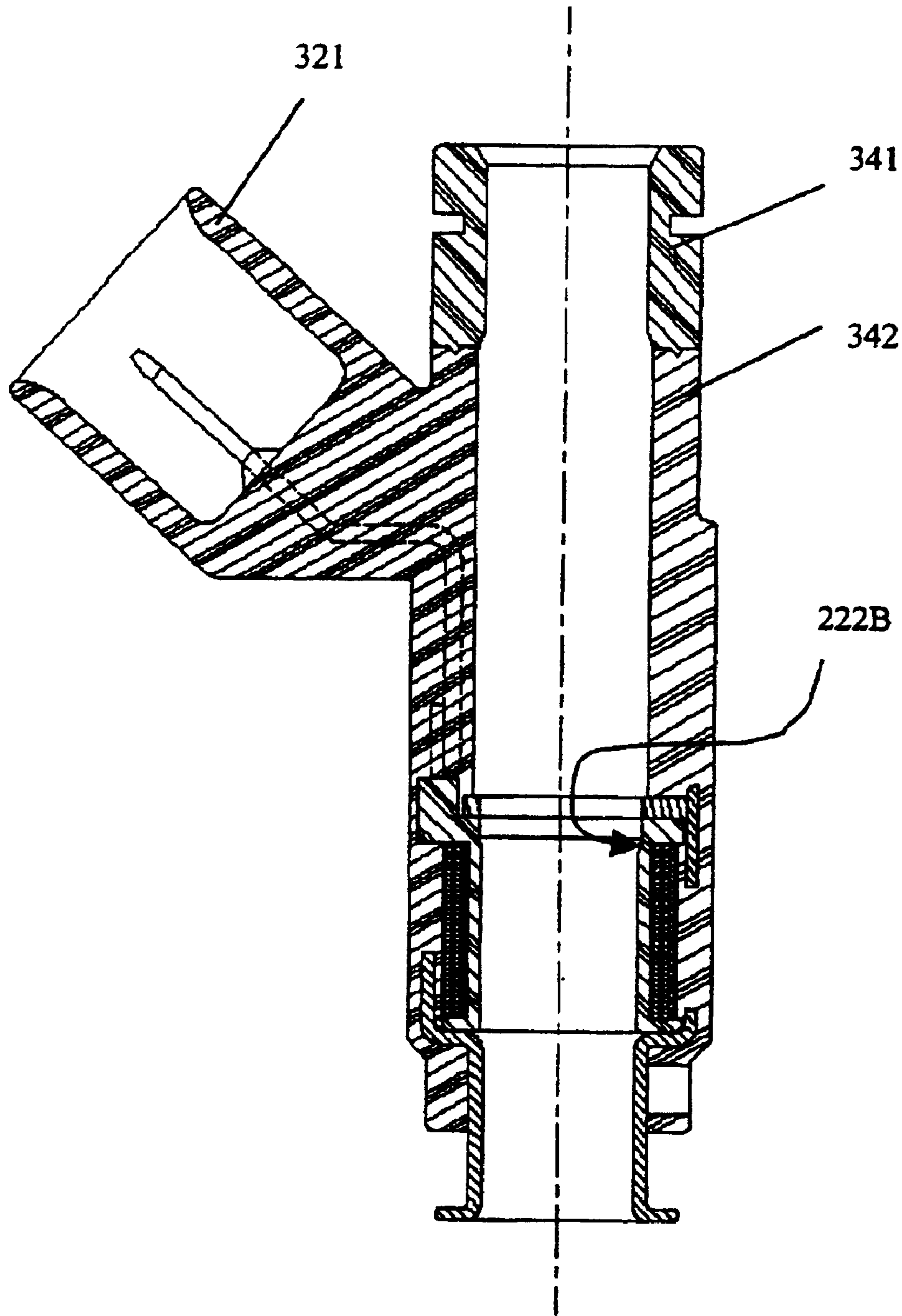

FIG. 3A

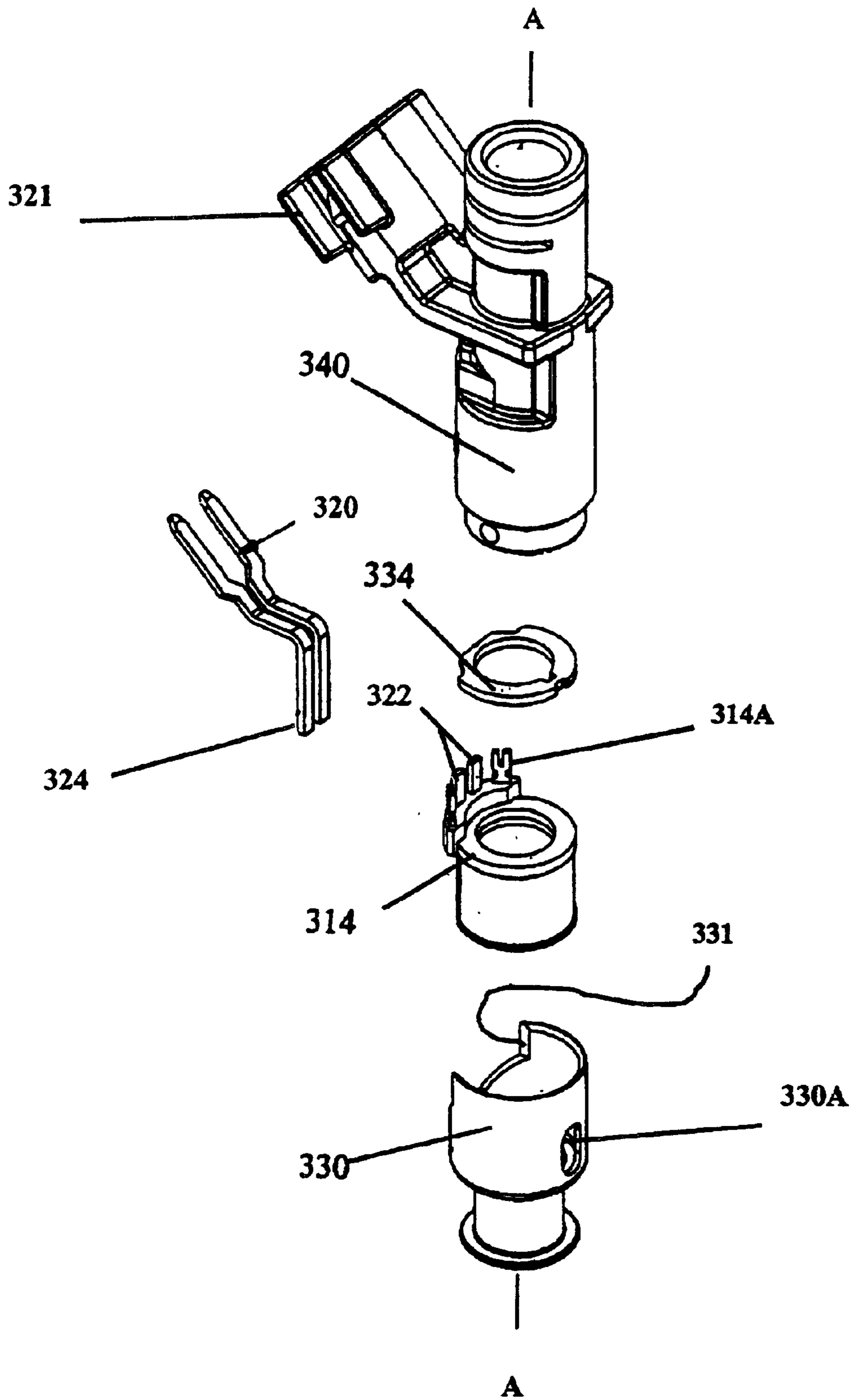

FIG. 3B

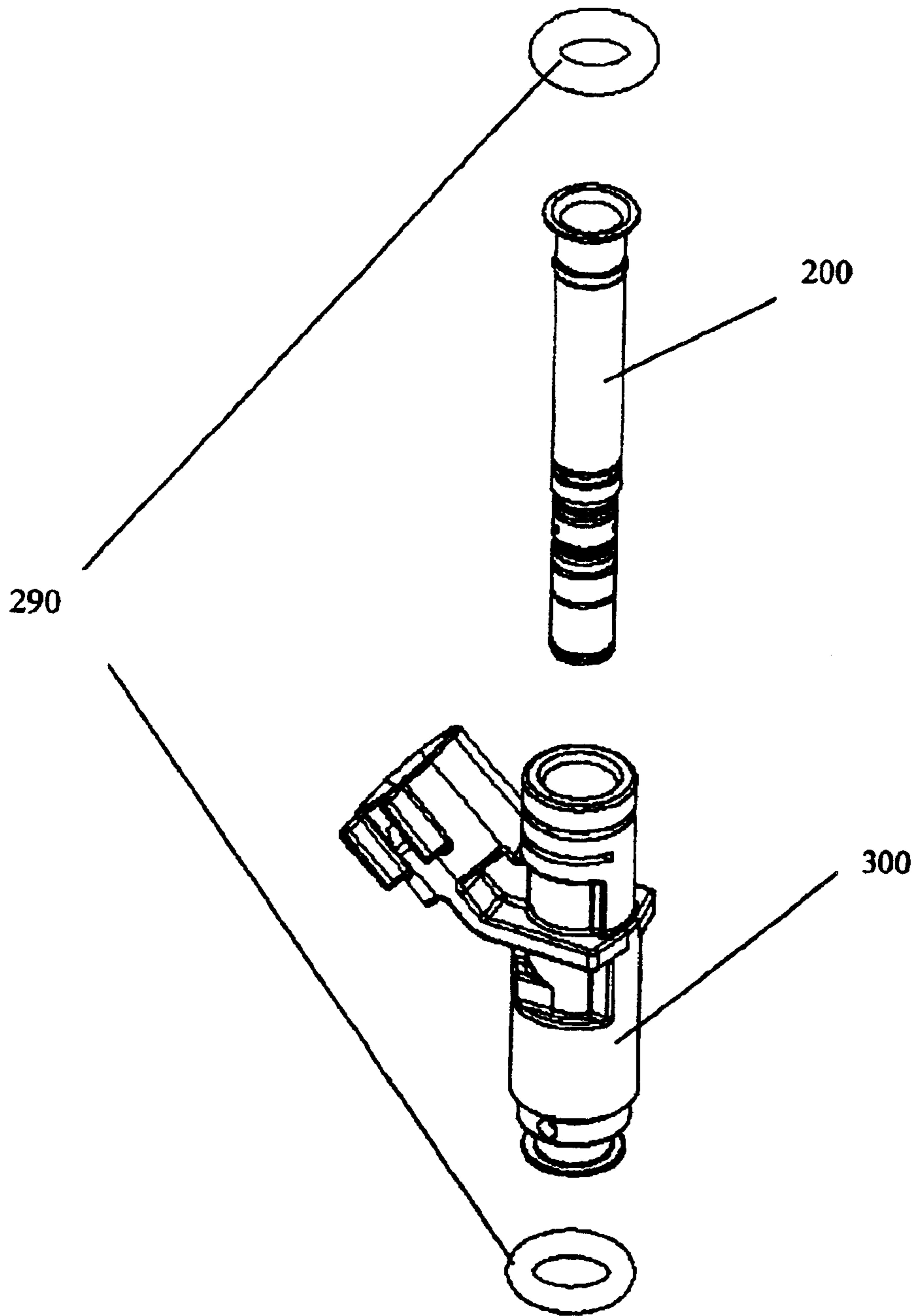

FIG. 4

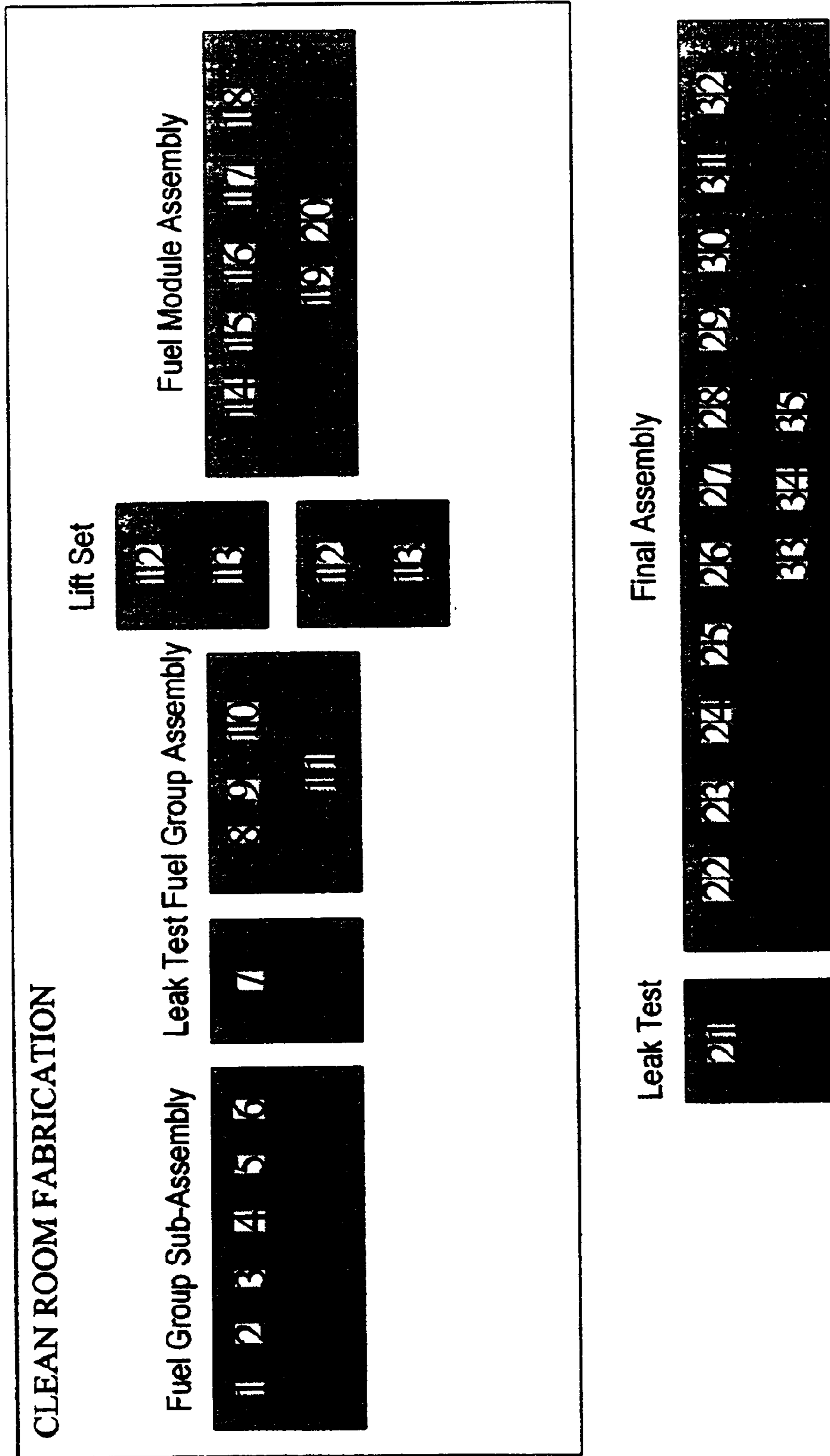

FIG. 5

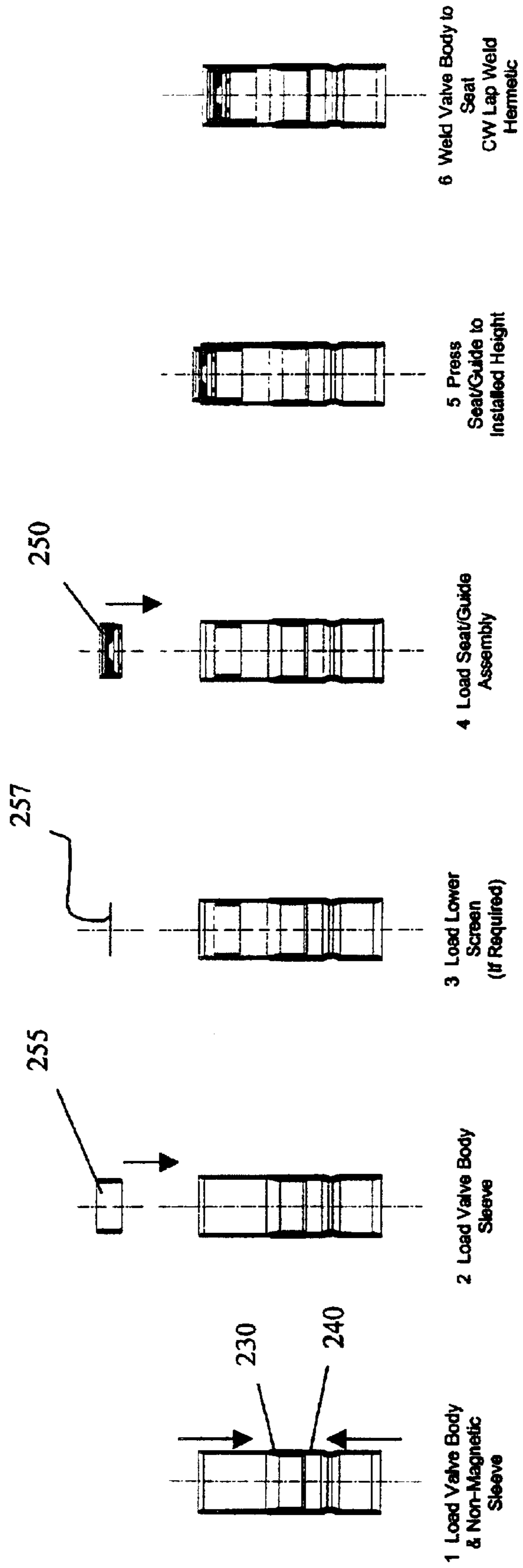

FIG. 5A

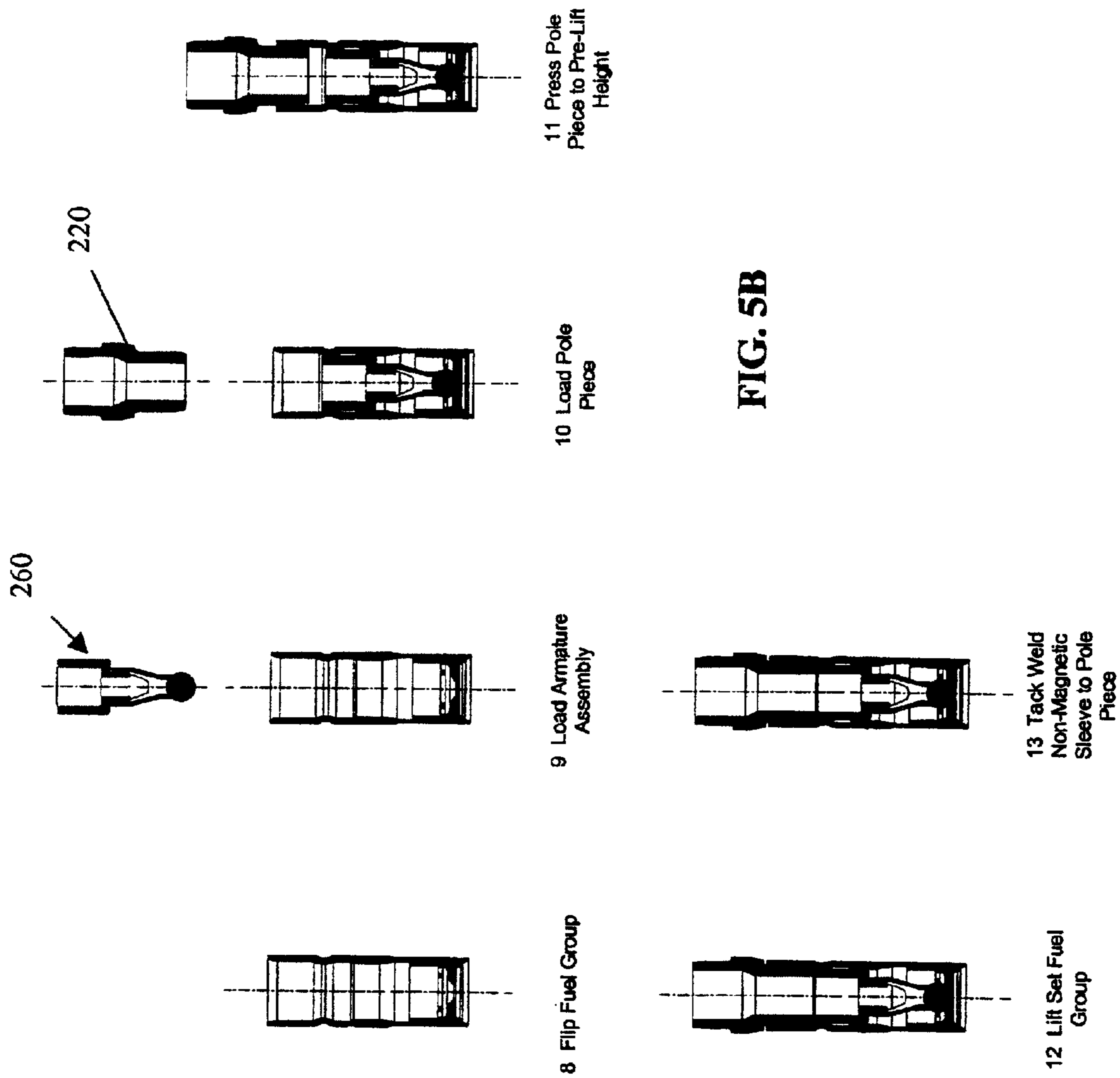
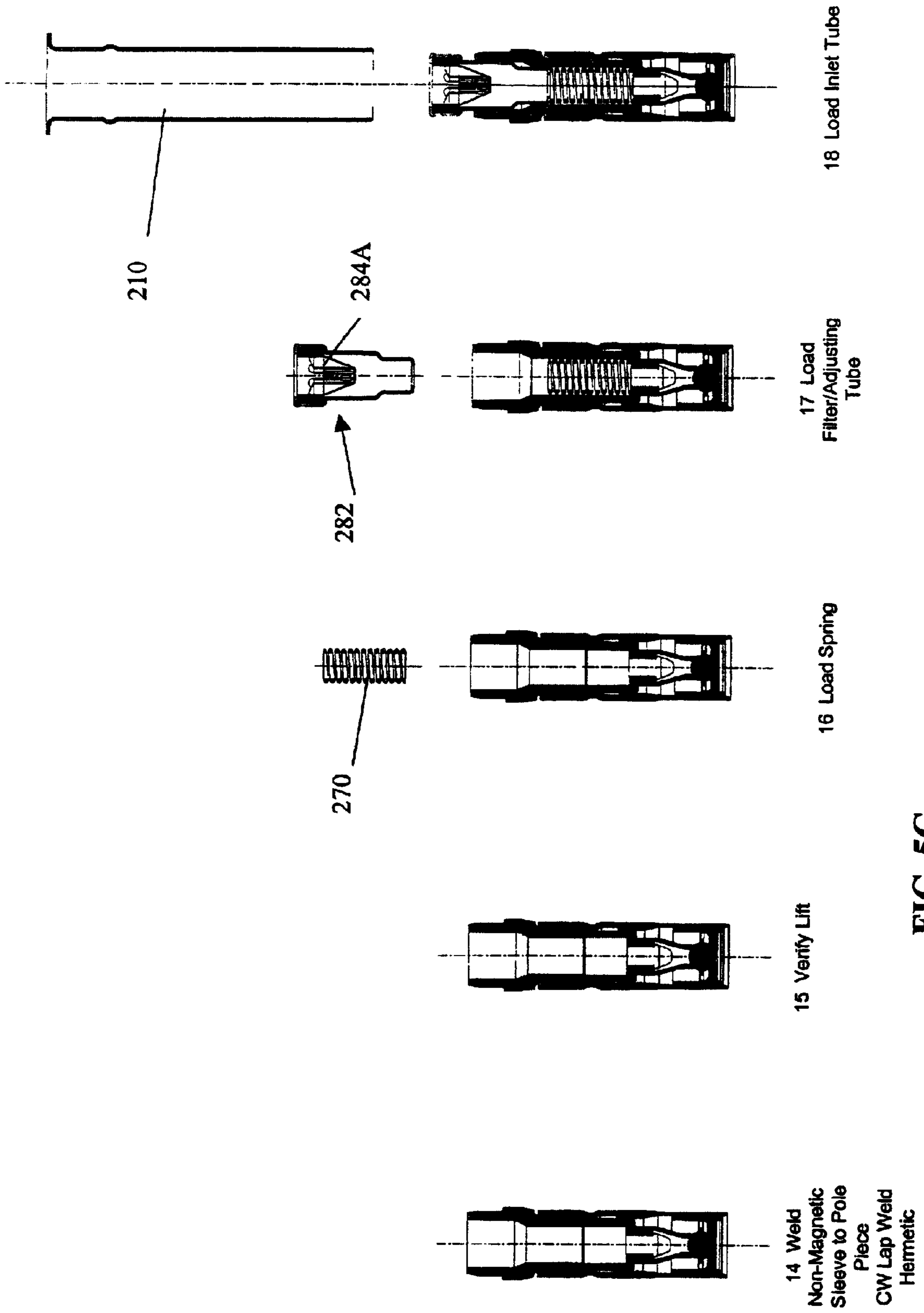

FIG. 5B



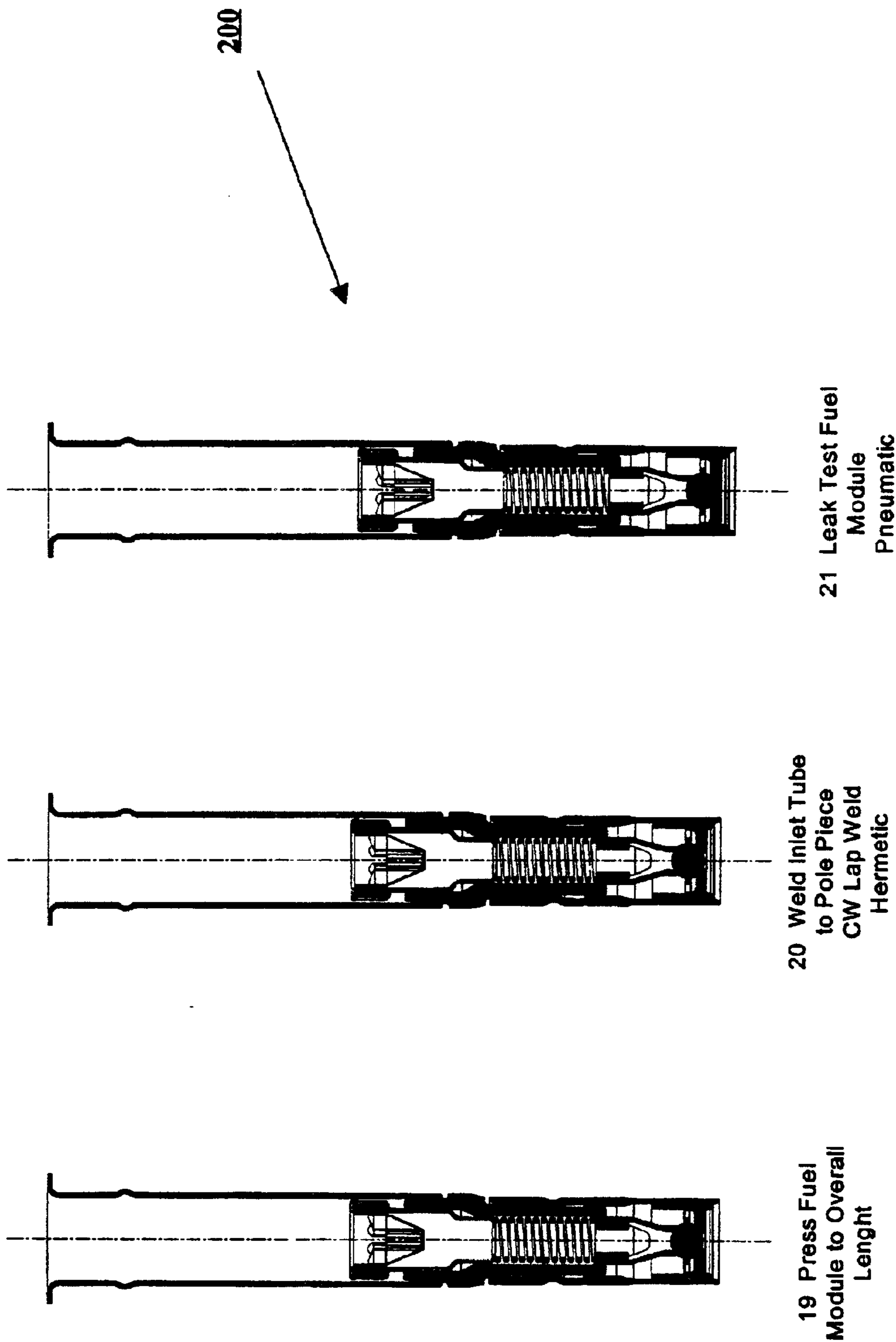
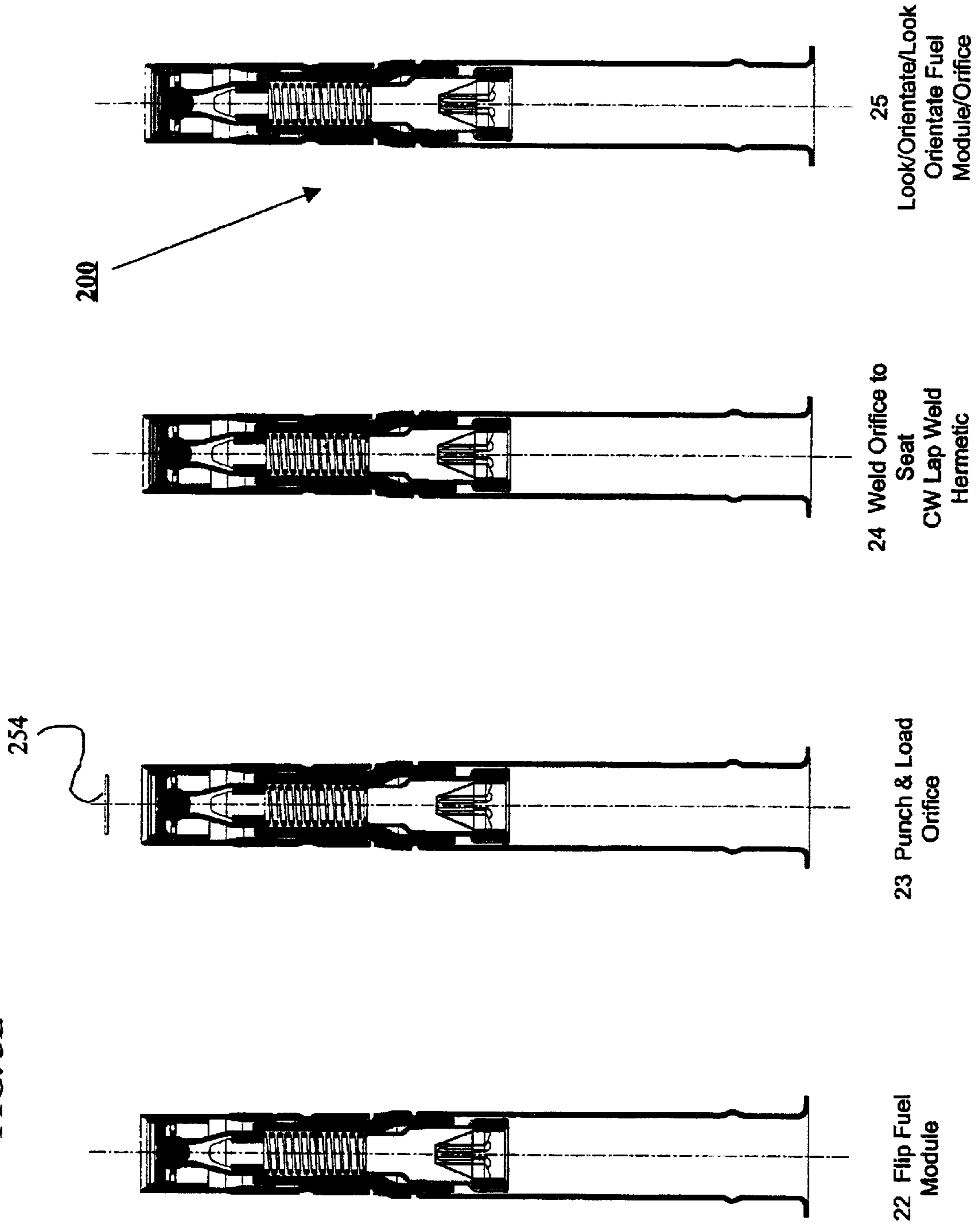
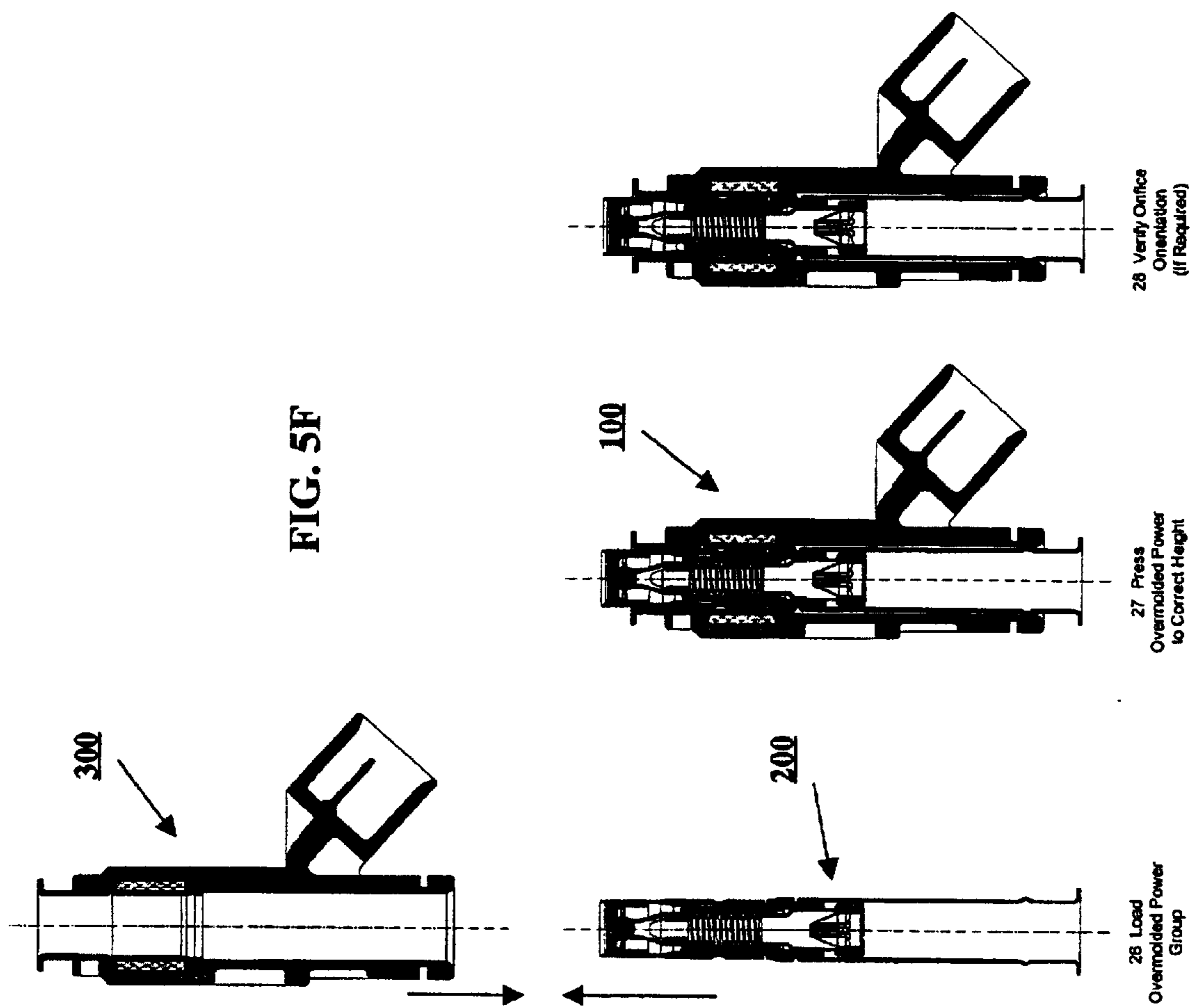

FIG. 5D

FIG. 5E





1

METHOD OF MANUFACTURING A MODULAR FUEL INJECTOR

BACKGROUND OF THE INVENTION

It is believed that examples of known fuel injection systems use an injector to dispense a quantity of fuel that is to be combusted in an internal combustion engine. It is also believed that the quantity of fuel that is dispensed is varied in accordance with a number of engine parameters such as engine speed, engine load, engine emissions, etc.

It is believed that examples of known electronic fuel injection systems monitor at least one of the engine parameters and electrically operate the injector to dispense the fuel. It is believed that examples of known injectors use electromagnetic coils, piezoelectric elements, or magnetostrictive materials to actuate a valve.

It is believed that examples of known valves for injectors include a closure member that is movable with respect to a seat. Fuel flow through the injector is believed to be prohibited when the closure member sealingly contacts the seat, and fuel flow through the injector is believed to be permitted when the closure member is separated from the seat.

It is believed that examples of known injectors include a spring providing a force biasing the closure member toward the seat. It is also believed that this biasing force is adjustable in order to set the dynamic properties of the closure member movement with respect to the seat.

It is further believed that examples of known injectors include a filter for separating particles from the fuel flow, and include a seal at a connection of the injector to a fuel source.

It is believed that such examples of the known injectors have a number of disadvantages.

It is believed that examples of known injectors must be assembled entirely in an environment that is substantially free of contaminants. It is also believed that examples of known injectors can only be tested after final assembly has been completed.

SUMMARY OF THE INVENTION

According to the present invention, a fuel injector can comprise a plurality of modules, each of which can be independently assembled and tested. According to one embodiment of the present invention, the modules can comprise a fluid handling subassembly and an electrical subassembly. These subassemblies can be subsequently assembled to provide a fuel injector according to the present invention.

The present invention provides method of manufacturing a fuel injector by providing a clean room, fabricating a fuel tube assembly, an armature assembly and fabricating a seat assembly in the clean room, assembling a fuel group by inserting an adjusting tube into the fuel tube assembly; inserting a biasing element into the fuel tube assembly; inserting the armature assembly into the fuel tube assembly; connecting the seat assembly to the fuel tube assembly; and inserting the fuel group into a power group outside the clean room.

The present invention further provides a method of assembling a fuel injector by providing a clean room, fabricating a fuel tube assembly, an armature assembly and a seat assembly in the clean room; assembling the fuel group by inserting an adjusting tube into the fuel tube assembly; inserting a biasing element into the fuel tube assembly;

2

inserting the armature assembly into the fuel tube assembly; and connecting the seat assembly to the fuel tube assembly.

BRIEF DESCRIPTION OF THE DRAWINGS

The accompanying drawings, which are incorporated herein and constitute part of this specification, illustrate an embodiment of the invention, and, together with the general description given above and the detailed description given below, serve to explain features of the invention.

FIG. 1 is a cross-sectional view of a fuel injector according to the present invention.

FIG. 2 is a cross-sectional view of a fluid handling subassembly of the fuel injector shown in FIG. 1.

FIG. 2A is a cross-sectional view of a variation on the fluid handling subassembly of FIG. 2.

FIGS. 2B and 2C are exploded views of the components of lift setting feature of the present invention.

FIG. 3 is a cross-sectional view of an electrical subassembly of the fuel injector shown in FIG. 1.

FIG. 3A is a cross-sectional view of the two overmolds for the electrical subassembly of FIG. 1.

FIG. 3B is an exploded view of the electrical subassembly of the fuel injector of FIG. 1.

FIG. 4 is an isometric view that illustrates assembling the fluid handling and electrical subassemblies that are shown in FIGS. 2 and 3, respectively.

FIG. 5 is a chart of the method of assembling the modular fuel injector of the present invention.

FIGS. 5A–5F are graphical illustrations of the method summarized in FIG. 5.

DETAILED DESCRIPTION OF THE PREFERRED EMBODIMENT

Referring to FIGS. 1–4, a solenoid actuated fuel injector **100** dispenses a quantity of fuel that is to be combusted in an internal combustion engine (not shown). The fuel injector **100** extends along a longitudinal axis A—A between a first injector end **238** and a second injector end **239**, and includes a valve group subassembly **200** and a power group subassembly **300**. The valve group subassembly **200** performs fluid handling functions, e.g., defining a fuel flow path and prohibiting fuel flow through the injector **100**. The power group subassembly **300** performs electrical functions, e.g., converting electrical signals to a driving force for permitting fuel flow through the injector **100**.

Referring to FIGS. 1 and 2, the valve group subassembly **200** comprises a tube assembly extending along the longitudinal axis A—A between a first tube assembly end **200A** and a second tube assembly end **200B**. The tube assembly includes at least an inlet tube, a non-magnetic shell **230**, and a valve body **240**. The inlet tube **210** has a first inlet tube end proximate to the first tube assembly end **200A**. A second end of the inlet tube **210** is connected to a first shell end of the non-magnetic shell **230**. A second shell end of the non-magnetic shell **230** is connected to a first valve body end of the valve body **240**. And a second valve body end of the valve body **240** is proximate to the second tube assembly end **200B**. The inlet tube **210** can be formed by a deep drawing process or by a rolling operation. A pole piece can be integrally formed at the second inlet tube end of the inlet tube **210** or, as shown, a separate pole piece **220** can be connected to a partial inlet tube **210** and connected to the first shell end of the nonmagnetic shell **230**. The non-magnetic shell **230** can comprise diamagnetic stainless steel

430FR, or any other suitable material demonstrating substantially equivalent structural and magnetic properties.

An armature assembly **260** is disposed in the tube assembly. The armature assembly **260** includes a first armature assembly end having a ferro-magnetic or armature portion **262** and a second armature assembly end having a sealing portion. The armature assembly **260** is disposed in the tube assembly such that the magnetic portion, or “armature,” **262** confronts the pole piece **220**. The sealing portion can include a closure member **264**, e.g., a spherical valve element, that is moveable with respect to the seat **250** and its sealing surface **252**. The closure member **264** is movable between a closed configuration, as shown in FIGS. **1** and **2**, and an open configuration (not shown). In the closed configuration, the closure member **264** contiguously engages the sealing surface **252** to prevent fluid flow through the opening. In the open configuration, the closure member **264** is spaced from the seat **250** to permit fluid flow through the opening. The armature assembly **260** may also include a separate intermediate portion **266** connecting the ferro-magnetic or armature portion **262** to the closure member **264**. The intermediate portion or armature tube **266** can be fabricated by various techniques, for example, a plate can be rolled and its seams welded or a blank can be deep-drawn to form a seamless tube. The intermediate portion **266** is preferable due to its ability to reduce magnetic flux leakage from the magnetic circuit of the fuel injector **100**. This ability arises from the fact that the intermediate portion or armature tube **266** can be non-magnetic, thereby magnetically decoupling the magnetic portion or armature **262** from the ferro-magnetic closure member **264**. Because the ferro-magnetic closure member **264** is decoupled from the ferro-magnetic or armature **262**, flux leakage is reduced, thereby improving the efficiency of the magnetic circuit. To reduce flux leakage, a nonmagnetic closure member **264** is can be used in conjunction with the non-magnetic armature tube **266**.

A seat **250** is secured at the second end of the tube assembly. The seat **250** defines an opening centered on the fuel injector’s longitudinal axis A—A and through which fuel can flow into the internal combustion engine (not shown). The seat **250** includes a sealing surface surrounding the opening. The sealing surface, which faces the interior of the valve body **240**, can be frustoconical or concave in shape, and can have a finished surface. An orifice plate **254** can be used in connection with the, seat **250** to provide at least one precisely sized and oriented orifice in order to obtain a particular fuel spray pattern.

With reference to FIG. **2B**, a lift sleeve **255** is telescopically mounted in the valve body **240** to set the seat **250** at a predetermined axial distance from the inlet tube **210** or the armature in the tube assembly. This feature can be seen in the exploded view of FIG. **2B** wherein the separation distance between the seat **250** and the armature can be set by inserting the lift sleeve **255** in a telescopic fashion into the valve body **240**. The use of lift sleeve **255** allows the injector lift to be set and, optionally, tested prior to final assembly of the injector. Furthermore, adjustment to the lift can be done by moving the lift sleeve **255** in either axial direction as opposed to scrapping the whole injector. Once the injector lift is determined to be correct, the lift sleeve **255** is affixed to the housing **330** by a laser weld.

Alternatively, a crush ring **256** can be used in lieu of a lift sleeve **255** to set the injector lift height, as shown in FIG. **2C**. The use of a crush ring **256** allows for quicker injector assembly when the dimensions of the inlet tube, non-magnetic shell **230**, valve body **240** and armature are fixed for a large production run.

An armature assembly **260** is disposed in the tube assembly. The armature assembly **260** includes a first armature assembly end having a ferro-magnetic or armature portion **262** and a second armature assembly end having a sealing portion. The armature assembly **260** is disposed in the tube assembly such that the magnetic portion, or “armature,” **262** confronts the pole piece **220**. The sealing portion can include a closure member **264**, e.g., a spherical valve element, that is moveable with respect to the seat **250** and its sealing surface **252**. The closure member **264** is movable between a closed configuration, as shown in FIGS. **1** and **2**, and an open configuration (not shown). In the closed configuration, the closure member **264** contiguously engages the sealing surface **252** to prevent fluid flow through the opening. In the open configuration, the closure member **264** is spaced from the seat **250** to permit fluid flow through the opening. The armature assembly **260** may also include a separate intermediate portion or armature tube **266** connecting the ferro-magnetic or armature portion **262** to the closure member **264**.

At least one axially extending through-bore **267** and at least one aperture **268** through a wall of the armature assembly **260** can provide fuel flow through the armature assembly **260**. The apertures **268**, which can be of any shape, preferably are axially elongated to facilitate the passage of gas bubbles. For example, in the case of a separate intermediate portion **266** that is formed by rolling a sheet substantially into a tube, the apertures **268** can be an axially extending slit defined between non-abutting edges of the rolled sheet. The apertures **268** provide fluid communication between the at least one through-bore **267** and the interior of the valve body **240**. Thus, in the open configuration, fuel can be communicated from the through-bore **267**, through the apertures **268** and the interior of the valve body **240**, around the closure member **264**, and through the opening into the engine (not shown).

In the case of a spherical valve element providing the closure member **264**, the spherical valve element can be connected to the armature assembly **260** at a diameter that is less than the diameter of the spherical valve element. Such a connection would be on side of the spherical valve element that is opposite contiguous contact with the seat. A lower armature guide **257** can be disposed in the tube assembly, proximate the seat, and would slidingly engage the diameter of the spherical valve element. The lower armature guide **257** can facilitate alignment of the armature assembly **260** along the axis A—A, and while the armature tube **266** can magnetically decouple the closure member **264** from the ferro-magnetic or armature portion **262** of the armature assembly **260**.

A resilient member **270** is disposed in the tube assembly and biases the armature assembly **260** toward the seat. A filter assembly **282** comprising a filter **284A** and an adjusting tube **280** is also disposed in the tube assembly. The filter assembly **282** includes a first end and a second end. The filter **284A** is disposed at one end of the filter assembly **282** and also located proximate to the first end of the tube assembly and apart from the resilient member **270** while the adjusting tube **280** is disposed generally proximate to the second end of the tube assembly. The adjusting tube **280** engages the resilient member **270** and adjusts the biasing force of the member with respect to the tube assembly. In particular, the adjusting tube **280** provides a reaction member against which the resilient member **270** reacts in order to close the injector valve **100** when the power group subassembly **300** is de-energized. The position of the adjusting tube **280** can be retained with respect to the inlet tube **210** by an inter-

ference fit between an outer surface of the adjusting tube **280** and an inner surface of the tube assembly. Thus, the position of the adjusting tube **280** with respect to the inlet tube **210** can be used to set a predetermined dynamic characteristic of the armature assembly **260**. Alternatively, as shown in FIG. **2A**, a filter assembly **282'** comprising adjusting tube **280A** and inverted cup-shaped filtering element **284B** can be utilized in place of the cone type filter assembly **282**.

The valve group subassembly **200** can be assembled as follows. The non-magnetic shell **230** is connected to the inlet tube **210** and to the valve body **240**. The filter assembly **282** or **282'** is inserted along the axis A—A from the first inlet tube end **200A** of the inlet tube **210**. Next, the resilient member **270** and the armature assembly **260** (which was previously assembled) are inserted along the axis A—A from the second valve body end of the valve body **240**. The filter assembly **282** or **282'** can be inserted into the inlet tube **210** to a predetermined distance so as to abut the resilient member. The position of the filter assembly **282** or **282'** with respect to the inlet tube **210** can be used to adjust the dynamic properties of the resilient member, e.g., so as to ensure that the armature assembly **260** does not float or bounce during injection pulses. The seat **250** and orifice plate **254** are then inserted along the axis A—A from the second valve body end of the valve body **240**. At this time, a probe can be inserted from either the inlet end or the orifice to check for the lift of the injector. If the injector lift is correct, the lift sleeve **255** and the seat **250** are fixedly attached to the valve body **240**. It should be noted here that both the seat **250** and the lift sleeve **255** are fixedly attached to the valve body **240** by known conventional attachment techniques, including, for example, laser welding, crimping, and friction welding or conventional welding, and preferably laser welding. The seat **250** and orifice plate **254** can be fixedly attached to one another or to the valve body **240** by known attachment techniques such as laser welding, crimping, friction welding, conventional welding, etc.

Referring to FIGS. **1** and **3**, the power group subassembly **300** comprises an electromagnetic coil **310**, at least one terminal **320** (there are two according to a preferred embodiment), a housing **330**, and an overmold **340**. The electromagnetic coil **310** comprises a wire that can be wound on a bobbin **314** and electrically connected to electrical contact **322** supported on the bobbin **314**. When energized, the coil generates magnetic flux that moves the armature assembly **260** toward the open configuration, thereby allowing the fuel to flow through the opening. De-energizing the electromagnetic coil **310** allows the resilient member **270** to return the armature assembly **260** to the closed configuration, thereby shutting off the fuel flow. Each electrical terminal **320** is in electrical communication via an axially extending contact portion **324** with a respective electrical contact **322** of the coil **310**. The housing **330**, which provides a return path for the magnetic flux, generally comprises a ferromagnetic cylinder **332** surrounding the electromagnetic coil **310** and a flux washer **334** extending from the cylinder toward the axis A—A. The flux washer **334** can be integrally formed with or separately attached to the cylinder. The housing **330** can include holes and slots **330A**, or other features to break-up eddy currents that can occur when the coil is energized. Additionally, the housing **330** is provided with scalloped circumferential edge **331** to provide a mounting relief for the bobbin **314**. The overmold **340** maintains the relative orientation and position of the electromagnetic coil **310**, the at least one electrical terminal **320**, and the housing **330**. The overmold **340** can also form an electrical harness connector portion **321** in which a

portion of the terminals **320** are exposed. The terminals **320** and the electrical harness connector portion **321** can engage a mating connector, e.g., part of a vehicle wiring harness (not shown), to facilitate connecting the injector **100** to a supply of electrical power (not shown) for energizing the electromagnetic coil **310**.

According to a preferred embodiment, the magnetic flux generated by the electromagnetic coil **310** flows in a circuit that comprises the pole piece **220**, a working air gap between the pole piece **220** and the magnetic armature portion **262**, a parasitic air gap between the magnetic armature portion **262** and the valve body **240**, the housing **330**, and the flux washer **334**.

The coil group subassembly **300** can be constructed as follows. As shown in FIG. **3B**, a plastic bobbin **314** can be molded with the electrical contacts **322**. The wire **312** for the electromagnetic coil **310** is wound around the plastic bobbin **314** and connected to the electrical contact **322**. The housing **330** is then placed over the electromagnetic coil **310** and bobbin **314** unit. The bobbin **314** can be formed with at least one retaining prongs **314A** which, in combination with an overmold **340**, are utilized to fix the bobbin **314** to the overmold **340** once the overmold is formed. The terminals **320** are pre-bent to a proper configuration such that the pre-aligned terminals **320** are in alignment with the to-be-formed harness connector **321** when a polymer is poured or injected into a mold (not shown) for the electrical subassembly. The terminals **320** are then electrically connected via the axially extending portion **324** to respective electrical contacts **322**. The completed bobbin **314** is then placed into the housing **330** at a proper orientation by virtue of the scalloped-edge **331**. An overmold **340** is then formed to maintain the relative assembly of the coil/bobbin unit, housing **330**, and terminals **320**. The overmold **340** also provides a structural case for the injector and provides predetermined electrical and thermal insulating properties. A separate collar (not shown) can be connected, e.g., by bonding, and can provide an application specific characteristic such as orientation identification features for the injector **100**. Thus, the overmold **340** provides a universal arrangement that can be modified with the addition of a suitable collar. To reduce manufacturing and inventory costs, the coil/bobbin unit can be the same for different applications. As such, the terminals **320** and overmold **340** (or collar, if used) can be varied in size and shape to suit particular tube assembly lengths, mounting configurations, electrical connectors, etc.

Alternatively, as shown in FIG. **3A**, a two-piece overmold allows for a first overmold **341** that is application specific while the second overmold **342** can be for all applications. The first overmold **341** is bonded to a second overmold **342**, allowing both to act as electrical and thermal insulators for the injector. Additionally, a portion of the housing **330** can project beyond the over-mold to allow the injector to accommodate different injector tip lengths.

As is particularly shown in FIGS. **1** and **4**, the valve group subassembly **200** can be inserted into the coil group subassembly **300**. Thus, the injector **100** is made of two modular subassemblies that can be assembled and tested separately, and then connected together to form the injector **100**. The valve group subassembly **200** and the coil group subassembly **300** can be fixedly attached by adhesive, welding, or another equivalent attachment process. According to a preferred embodiment, a hole **360** through the overmold **340** exposes the housing **330** and provides access for laser welding the housing **330** to the valve body **240**. The O-rings **290** can be mounted at the respective first and second injector ends **238** and **239**.

The first injector end **238** can be coupled to the fuel supply of an internal combustion engine (not shown). The O-ring **290** can be used to seal the first injector end **238** to the fuel supply so that fuel from a fuel rail (not shown) is supplied to the tube assembly, with the O-ring **290** making a fluid tight seal, at the connection between the injector **100** and the fuel rail (not shown).

In operation, the electromagnetic coil **310** is energized, thereby generating magnetic flux in the magnetic circuit. The magnetic flux moves armature assembly **260** (along the axis A—A, according to a preferred embodiment) towards the integral pole piece **220**, i.e., closing the working air gap. This movement of the armature assembly **260** separates the closure member **264** from the seat **250** and allows fuel to flow from the fuel rail (not shown), through the inlet tube **210**, the through-bore **267**, the apertures **268** and the valve body **240**, between the seat **250** and the closure member **264**, through the opening, and finally through the orifice disk **254** into the internal combustion engine (not shown). When the electromagnetic coil **310** is de-energized, the armature assembly **260** is moved by the bias of the resilient member **270** to contiguously engage the closure member **264** with the seat **250**, and thereby prevent fuel flow through the injector **100**.

Referring to FIGS. 5, 5A–5F, a preferred assembly process can be as follows:

1. A pre-assembled valve body and non-magnetic sleeve is located with the valve body oriented up in a clean room.
2. A screen retainer, e.g., a lift sleeve, is loaded into the valve body/nonmagnetic sleeve assembly.
3. A lower screen can be loaded into the valve body/non-magnetic sleeve assembly.
4. A pre-assembled seat and guide assembly is loaded into the valve body/non-magnetic sleeve assembly.
5. The seat/guide assembly is pressed to a desired position within the valve body/non-magnetic sleeve assembly.
6. The valve body is welded, e.g., by a continuous wave laser forming a hermetic lap seal, to the seat.
7. A first leak test is performed on the valve body/non-magnetic sleeve assembly. This test can be performed pneumatically.
8. The valve body/non-magnetic sleeve assembly is inverted so that the non-magnetic sleeve is oriented up.
9. An armature assembly is loaded into the valve body/non-magnetic sleeve assembly.
10. A pole piece is loaded into the valve body/non-magnetic sleeve assembly and pressed to a pre-lift position.
11. Dynamically, e.g., pneumatically, purge valve body/non-magnetic sleeve assembly.
12. Set lift.
13. The non-magnetic sleeve is welded, e.g., with a tack weld, to the pole piece.
14. The non-magnetic sleeve is welded, e.g., by a continuous wave laser forming a hermetic lap seal, to the pole piece.
15. Verify lift
16. A spring is loaded into the valve body/non-magnetic sleeve assembly.
17. A filter/adjusting tube is loaded into the valve body/non-magnetic sleeve assembly and pressed to a pre-cal position.
18. An inlet tube is connected to the valve body/non-magnetic sleeve assembly to generally establish the fuel group subassembly.

19. Axially press the fuel group subassembly to the desired over-all length.
20. The inlet tube is welded, e.g., by a continuous wave laser forming a hermetic lap seal, to the pole piece.
21. A second leak test is performed on the fuel group subassembly. This test can be performed pneumatically.
22. The fuel group subassembly can be moved outside the clean room and inverted so that the seat is oriented up.
23. An orifice is punched and loaded on the seat.
24. The orifice is welded, e.g., by a continuous wave laser forming a hermetic lap seal, to the seat.
25. The rotational orientation of the fuel group subassembly/orifice can be established with a “look/orient/look” procedure.
26. The fuel group subassembly is inserted into the (pre-assembled) power group subassembly.
27. The power group subassembly is pressed to a desired axial position with respect to the fuel group subassembly.
28. The rotational orientation of the fuel group subassembly/orifice/power group subassembly can be verified.
29. The power group subassembly can be laser marked with information such as part number, serial number, performance data, a logo, etc.
30. Perform a high-potential electrical test.
31. The housing of the power group subassembly is tack welded to the valve body.
32. A lower O-ring can be installed. Alternatively, this lower O-ring can be installed as a post test operation.
33. An upper O-ring is installed.
34. Invert the fully assembled fuel injector.
35. Transfer the injector to a test rig.

To ensure that particulates from the manufacturing environment will not contaminate the fuel group subassembly, the process of fabricating the fuel group subassembly is preferably performed within a “clean room.” “Clean room” here means that the manufacturing environment is provided with an air filtration system that will ensure that the particulates and environmental contaminants will be removed from the clean room.

Despite the use of a clean room, however, particulates such as polymer flashing and metal burrs may still be present in the partially assembled fuel group. Such particulates, if not removed from the fuel injector, may cause the completed injector to jam open, the effects, which may include engine inefficiency or even a hydraulic lock of the engine. To prevent such a scenario, the process can utilize at least a washing process after a first leak test and a prior to a final flush process during break-in (or bum-in) of the injector.

To set the lift, i.e., ensure the proper injector lift distance, there are at least four different techniques that can be utilized. According to a first technique, a crush ring that is inserted into the valve body **240** between the lower guide **257** and the valve body **240** can be deformed. According to a second technique, the relative axial position of the valve body **240** and the nonmagnetic shell **230** can be adjusted before the two parts are affixed together. According to a third technique, the relative axial position of the non-magnetic shell **230** and the pole piece **220** can be adjusted before the two parts are affixed together. And according to a fourth technique, a lift sleeve **255** can be displaced axially within the valve body **240**. If the lift sleeve technique is used, the position of the lift sleeve can be adjusted by moving the lift

sleeve axially. The lift distance can be measured with a test probe. Once the lift is correct, the sleeve is welded to the valve body **240**, e.g., by laser welding. Next, the valve body **240** is attached to the inlet tube **210** assembly by a weld, preferably a laser weld. The assembled fuel group sub-assembly **200** is then tested, e.g., for leakage.

As is shown in FIGS. **5**, **5B** and **5C**, the lift set procedure may not be able to progress at the same rate as the other procedures. Thus, a single production line can be split into a plurality (two are shown) of parallel lift setting stations, which can thereafter be recombined back into a single production line.

The preparation of the power group sub-assembly, which can include (a) the housing **330**, (b) the bobbin assembly including the terminals **320**, (c) the flux washer **334**, and (d) the overmold **340**, can be performed separately from the fuel group subassembly.

According to a preferred embodiment, wire **312** is wound onto a pre-formed bobbin **314** with at least one electrical contact **322** molded thereon. The bobbin assembly is inserted into a preformed housing **330**. To provide a return path for the magnetic flux between the pole piece **220** and the housing **330**, flux washer **334** is mounted on the bobbin assembly. A pre-bent terminal **320** having axially extending connector portions **324** are coupled to the electrical contact portions **322** and brazed, soldered welded, or preferably resistance welded. The partially assembled power group assembly is now placed into a mold (not shown). By virtue of its pre-bent shape, the terminals **320** will be positioned in the proper orientation with the harness connector **321** when a polymer is poured or injected into the mold. Alternatively, two separate molds (not shown) can be used to form a two-piece overmold as described with respect to FIG. **3A**. The assembled power group subassembly **300** can be mounted on a test stand to determine the solenoid's pull force, coil resistance and the drop in voltage as the solenoid **310** is saturated.

The inserting of the fuel group subassembly **200** into the power group subassembly **300** operation, shown in FIG. **5E**, can involve setting the relative rotational orientation of fuel group subassembly **200** with respect to the power group subassembly **300**. According to the preferred embodiments, the fuel group can be rotated such that the included angle between a reference point on the orifice plate **254** and a reference point on the injector harness connector **321** is within a predetermined angle. The relative orientation can be set using robotic cameras or computerized imaging devices to look at respective predetermined reference points on the subassemblies, calculating the amount of rotation required as a function of the difference in the angle between the reference points, orientating the subassemblies and then checking with another look and so on until the subassemblies are properly orientated. Once the desired orientation is achieved, the subassemblies are then inserted together.

The inserting operation can be accomplished by one of two methods: "top-down" or "bottom-up." According to the former, the power group subassembly **300** is slid downward from the top of the fuel group subassembly **200**, and according to the latter, the power group subassembly **300** is slid upward from the bottom of the fuel group subassembly **200**. In situations where the inlet tube **210** assembly includes a flared first end, bottom-up method is required. Also in these situations, the O-ring **290** that is retained by the flared first end can be positioned around the power group subassembly **300** prior to sliding the fuel group subassembly **200** into the power group subassembly **300**. After inserting the fuel group subassembly **200** into the power group sub-

assembly **300**, these two subassemblies are affixed together, e.g., by welding, such as laser welding. According to a preferred embodiment, the overmold **340** includes an opening **360** that exposes a portion of the housing **330**. This opening **360** provides access for a welding implement to weld the housing **330** with respect to the valve body **240**. Of course, other methods or affixing the subassemblies with respect to one another can be used. Finally, the O-ring **290** at either end of the fuel injector can be installed.

The method of assembly of the preferred embodiments, and the preferred embodiments themselves, are believed to provide manufacturing advantages and benefits. For example, because of the modular arrangement only the valve group subassembly is required to be assembled in a "clean" room environment. The power group subassembly **300** can be separately assembled outside such an environment, thereby reducing manufacturing costs. Also, the modularity of the subassemblies permits separate pre-assembly testing of the valve and the coil assemblies. Since only those individual subassemblies that test unacceptable are discarded, as opposed to discarding fully assembled injectors, manufacturing costs are reduced. Further, the use of universal components (e.g., the coil/bobbin unit, non-magnetic shell **230**, seat **250**, closure member **264**, filter/retainer assembly **282**, etc.) enables inventory costs to be reduced and permits a "just-in-time" assembly of application specific injectors. Only those components that need to vary for a particular application, e.g., the terminal **320** and inlet tube **210** need to be separately stocked. Another advantage is that by locating the working air gap, i.e., between the armature assembly **260** and the pole piece **220**, within the electromagnetic coil, the number of windings can be reduced. In addition to cost savings in the amount of wire **312** that is used, less energy is required to produce the required magnetic flux and less heat builds-up in the coil (this heat must be dissipated to ensure consistent operation of the injector). Yet another advantage is that the modular construction enables the orifice disk **254** to be attached at a later stage in the assembly process, even as the final step of the assembly process. This just-in-time assembly of the orifice disk **254** allows the selection of extended valve bodies depending on the operating requirement. Further advantages of the modular assembly include out-sourcing construction of the power group subassembly **300**, which does not need to occur in a clean room environment. And even if the power group subassembly **300** is not out-sourced, the cost of providing additional clean room space is reduced.

While the present invention has been disclosed with reference to certain embodiments, numerous modifications, alterations, and changes to the described embodiments are possible without departing from the sphere and scope of the present invention, as defined in the appended claims. Accordingly, it is intended that the present invention not be limited to the described embodiments, but that it have the full scope defined by the language of the following claims, and equivalents thereof

What is claimed is:

1. A method of manufacturing a fuel injector comprising:
 - providing a clean room;
 - fabricating a fuel tube assembly in the clean room;
 - fabricating an armature assembly in the clean room;
 - fabricating a seat assembly in the clean room;
 - assembling a fuel group by performing the following processes:
 - inserting an adjusting tube into the fuel tube assembly;
 - inserting a biasing element into the fuel tube assembly;

11

inserting the armature assembly into the fuel tube assembly; and
connecting the seat assembly to the fuel tube assembly;
and
washing the fuel group; and
inserting the fuel group into a power group outside the clean room.

2. The method according to claim 1, wherein fabricating the fuel tube assembly comprises fixedly connecting an inlet tube to a magnetic pole piece.

3. The method according to claim 1, wherein fabricating the fuel tube assembly comprises fixedly connecting a magnetic pole piece to a non-magnetic shell.

4. The method according to claim 1, wherein fabricating the fuel tube assembly comprises fixedly connecting a non-magnetic shell to a valve body.

5. The method according to claim 1, wherein fabricating the armature assembly comprises fixedly connecting a magnetic armature to a preferably non-magnetic sealing element.

6. The method according to claim 5, further comprising fixedly connecting an armature tube between the magnetic armature and the sealing element.

7. The method according to claim 1, wherein fabricating the seat assembly comprises fixedly connecting a sealing element guide to a valve seat.

8. The method according to claim 1, further comprising installing a filter into the fuel tube assembly.

9. The method according to claim 8, wherein the filter is fixedly connected to the adjusting tube.

10. The method according to claim 1, wherein the connecting of the seat assembly comprises forming hermetic seal between an orifice disc and a surface of the seat assembly outside of the clean room.

11. The method according to claim 10, wherein the connecting of the seat assembly comprises welding through outer and inner surfaces of a valve body to the circumferential surface of the seat assembly so that a hermetic seal is formed between the inner surface of the valve body and the circumferential surface of the seat assembly.

12. The method according to claim 1, wherein the inserting comprises rotating the fuel group relative to the power group to at least one reference point provided on either of the fuel group or power group.

13. A method of assembling a fuel group comprising:
providing a clean room;
fabricating a fuel tube assembly in the clean room;
fabricating an armature assembly in the clean room;
fabricating a seat assembly in the clean room;

12

assembling the fuel group by performing the following processes:
inserting an adjusting tube into the fuel tube assembly;
inserting a biasing element into the fuel tube assembly;
inserting the armature assembly into the fuel tube assembly; and
connecting the seat assembly to the fuel tube assembly;
and
washing the fuel group.

14. The method according to claim 13, wherein the fabricating of an armature assembly further comprises setting an injector lift height.

15. The method according to claim 13, wherein fabricating the fuel tube assembly comprises fixedly connecting an inlet tube to a magnetic pole piece.

16. The method according to claim 13, wherein fabricating the fuel tube assembly comprises fixedly connecting a magnetic pole piece to a non-magnetic shell.

17. The method according to claim 13, wherein fabricating the fuel tube assembly comprises fixedly connecting a non-magnetic shell to a valve body.

18. The method according to claim 13, wherein fabricating the armature assembly comprises fixedly connecting a magnetic armature to a preferably non-magnetic sealing element.

19. The method according to claim 18, further comprising fixedly connecting an armature tube between the magnetic armature and the sealing element.

20. The method according to claim 19, wherein the armature tube is non-magnetic.

21. The method according to claim 13, wherein fabricating the seat assembly comprises fixedly connecting a sealing element guide to a valve seat.

22. The method according to claim 13, further comprising installing a filter into the fuel tube assembly.

23. The method according to claim 22, wherein the filter is fixedly connected to the adjusting tube.

24. The method according to claim 13, wherein the assembling of the fuel group comprises forming hermetic seal between an orifice disc and a surface of the seat assembly outside of the clean room.

25. The method according to claim 24, wherein the connecting of the seat assembly comprises welding through outer and inner surfaces of a valve body to the circumferential surface of the seat assembly so that a hermetic seal is formed between the inner surface of the valve body and the circumferential surface of the seat assembly.

* * * * *