



US006881223B2

(12) **United States Patent**  
**Penn et al.**

(10) **Patent No.:** **US 6,881,223 B2**  
(45) **Date of Patent:** **Apr. 19, 2005**

(54) **EXPANDABLE STENT AND METHOD FOR DELIVERY OF SAME**

(75) Inventors: **Ian M. Penn**, Vancouver (CA); **Donald R. Ricci**, Vancouver (CA)

(73) Assignee: **Evysio Medical Devices ULC** (CA)

(\*) Notice: Subject to any disclaimer, the term of this patent is extended or adjusted under 35 U.S.C. 154(b) by 12 days.

(21) Appl. No.: **10/190,818**

(22) Filed: **Jul. 9, 2002**

(65) **Prior Publication Data**

US 2002/0169501 A1 Nov. 14, 2002

**Related U.S. Application Data**

(63) Continuation of application No. 10/073,277, filed on Feb. 13, 2002, which is a continuation of application No. 09/672,767, filed on Sep. 29, 2000, now Pat. No. 6,375,677, which is a continuation of application No. 09/142,508, filed on Feb. 16, 1999, now Pat. No. 6,217,608.

(30) **Foreign Application Priority Data**

Mar. 6, 1996 (CA) ..... 2171047  
May 3, 1996 (CA) ..... 2175722  
Sep. 17, 1996 (CA) ..... 2185740  
Dec. 10, 1996 (CA) ..... 2192520

(51) **Int. Cl.**<sup>7</sup> ..... **A61M 29/00**

(52) **U.S. Cl.** ..... **623/1.15**

(58) **Field of Search** ..... 606/108, 191,  
606/192, 194, 195, 198; 623/1.1-1.2, 23.64-23.7;  
600/1-3

(56) **References Cited**

**U.S. PATENT DOCUMENTS**

3,657,774 A 4/1972 Reynolds ..... 24/73 CF  
3,993,078 A 11/1976 Bergentz et al. .... 128/1 R  
4,503,569 A 3/1985 Dotter ..... 3/1.4  
4,553,545 A 11/1985 Maass et al. .... 128/341

4,580,568 A 4/1986 Gianturco ..... 128/345  
4,655,771 A 4/1987 Wallsten ..... 623/1  
4,681,110 A 7/1987 Wiktor ..... 128/343  
4,733,665 A 3/1988 Palmaz  
4,739,762 A 4/1988 Palmaz  
4,762,128 A 8/1988 Rosenbluth ..... 128/343  
4,768,507 A 9/1988 Fischell et al. .... 128/303 R

(Continued)

**FOREIGN PATENT DOCUMENTS**

CA 1239755 8/1988 ..... A61F/2/00  
CA 1245527 11/1988 ..... A61M/29/00  
CA 2134997 5/1996 ..... A61F/2/04

(Continued)

**OTHER PUBLICATIONS**

Lawrence et al., "Percutaneous Endovascular Graft: Experimental Evaluation," 1987 RSNA Annual Meeting, RADIOLOGY, vol. 163, pp. 357-360 (May 1987).

(Continued)

*Primary Examiner*—Vy Bui

(74) *Attorney, Agent, or Firm*—Katten Muchin Zavis Rosenman

(57) **ABSTRACT**

An expandable stent comprising a proximal end and a distal end in communication with one another and a tubular wall disposed between the proximal end and the distal end. The tubular wall has a longitudinal axis and a porous surface defined by a plurality of intersecting members comprising a series of longitudinal struts disposed substantially parallel to the longitudinal axis of the stent. Each longitudinal strut in the series comprises flexure means for substantially complementary extension and compression of a diametrically opposed pair of the longitudinal struts upon flexure of the stent. The stent is expandable from a first, contracted position to a second, expanded position upon the application of a radially outward force on the stent. The provision of such flexure means in the series of struts leads to a very desirable balance of lateral flexibility of the unexpanded stent and radial rigidity of the expanded stent.

**63 Claims, 13 Drawing Sheets**

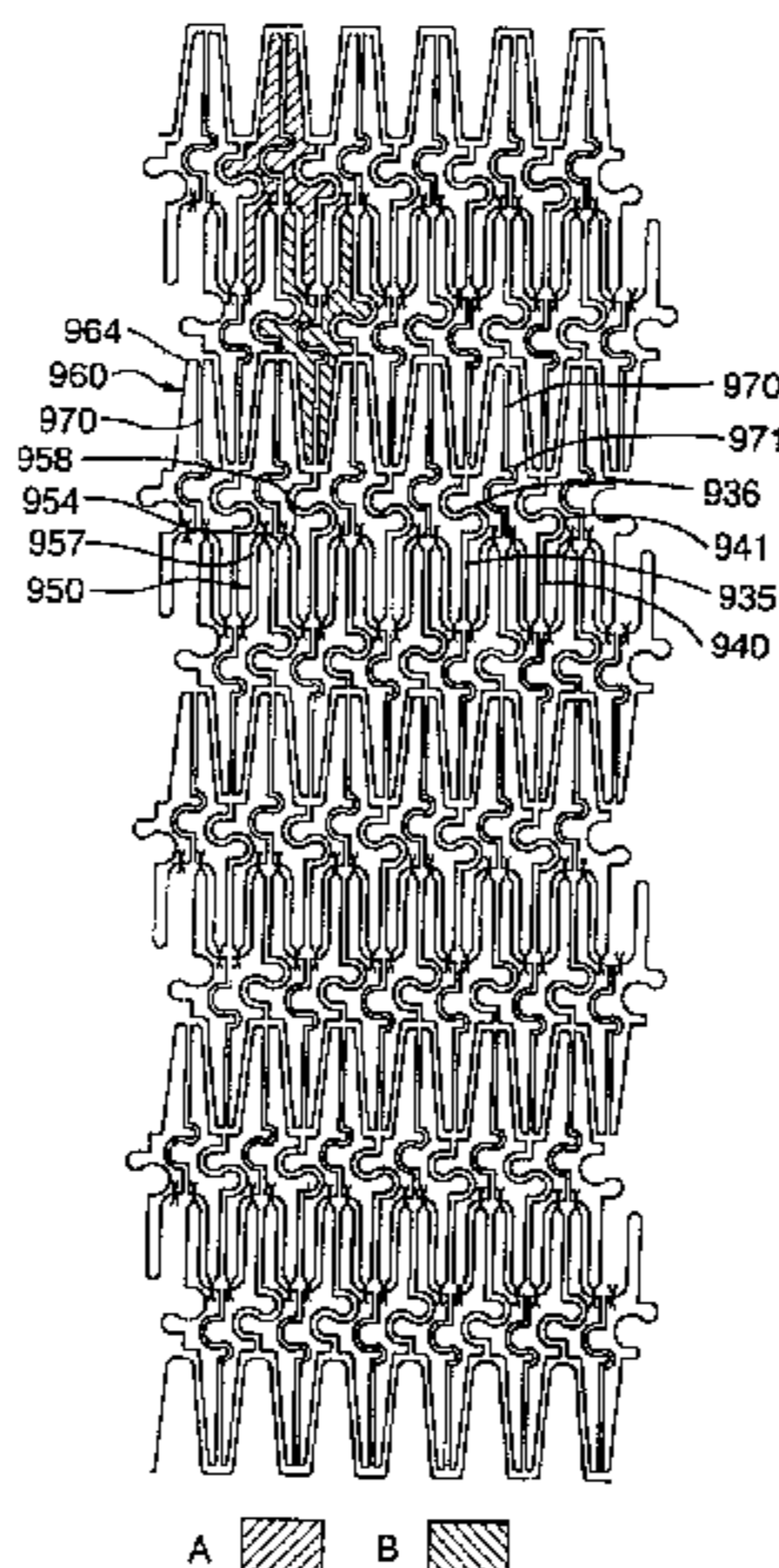



U.S. PATENT DOCUMENTS

4,795,458 A	1/1989	Regan .....	623/1	5,733,303 A	3/1998	Israel et al. ....	606/198
4,800,882 A	1/1989	Gianturco		5,755,734 A	5/1998	Richter et al. ....	606/194
4,830,003 A	5/1989	Wolff et al. ....	128/343	5,755,735 A	5/1998	Richter et al. ....	606/194
4,856,516 A	8/1989	Hillstead .....	128/343	5,755,771 A	5/1998	Penn et al. ....	623/1
4,878,906 A	11/1989	Lindemann et al. ....	623/1	5,776,161 A	7/1998	Globerman .....	606/194
4,886,062 A	12/1989	Wiktor .....	128/343	5,807,404 A	9/1998	Richter .....	623/1
4,907,336 A	3/1990	Gianturco .....	29/515	5,824,040 A	10/1998	Cox et al. ....	623/1
4,954,126 A	9/1990	Wallstén .....	600/36	5,827,320 A	10/1998	Richter et al. ....	606/194
4,969,458 A	11/1990	Wiktor .....	606/194	5,827,321 A	10/1998	Roubin et al. ....	606/195
4,994,071 A	2/1991	MacGregor .....	623/1	5,836,964 A	11/1998	Richter et al. ....	606/194
5,019,085 A	5/1991	Hillstead .....	606/108	5,836,966 A	11/1998	St. Germain .....	606/198
5,035,706 A	7/1991	Giantureo et al. ....	606/198	5,843,120 A	12/1998	Israel et al. ....	606/198
5,037,392 A	8/1991	Hillstead .....	604/96	5,868,783 A	2/1999	Tower .....	623/1
5,041,126 A	8/1991	Gianturco .....	606/195	5,879,370 A	3/1999	Fischell et al. ....	606/198
5,061,275 A	10/1991	Wallstén et al. ....	623/1	5,902,332 A	5/1999	Schatz .....	623/1
5,102,417 A	4/1992	Palmaz .....	606/195	5,906,640 A	5/1999	Penn et al. ....	623/1
5,104,404 A	4/1992	Wolff .....	623/1	5,906,759 A	5/1999	Richter .....	219/121.63
5,108,417 A	4/1992	Sawyer .....	606/198	5,911,754 A	6/1999	Kanesaka .....	623/1
5,116,365 A	5/1992	Hillstead .....	623/1	5,913,895 A	6/1999	Burpee et al. ....	623/1
5,133,732 A	7/1992	Wiktor .....	606/195	5,922,005 A	7/1999	Richter et al. ....	606/192
5,135,536 A	8/1992	Hillstead .....	606/195	5,931,866 A	8/1999	Frantzen .....	623/1
5,139,480 A	8/1992	Hickle .....	623/12	5,964,770 A	10/1999	Flomenblit et al. ....	606/78
5,147,385 A	9/1992	Beck et al. ....	623/1	5,964,798 A	10/1999	Imran .....	623/12
5,161,547 A	11/1992	Tower .....	128/898	5,980,552 A	11/1999	Pinchasik et al. ....	606/198
5,192,307 A	3/1993	Wall .....	623/1	5,997,703 A	12/1999	Richter .....	204/297
5,195,984 A	3/1993	Schatz .....	606/195	6,017,362 A	1/2000	Lau .....	623/1
5,197,978 A	3/1993	Hess .....	623/1	6,017,365 A	1/2000	Von Oepen .....	623/1
5,201,901 A	4/1993	Harada et al. ....	606/198	6,033,433 A	3/2000	Ehr .....	623/1
5,266,073 A	11/1993	Wall .....	623/1	6,042,597 A	3/2000	Kveen .....	623/1
5,269,802 A	12/1993	Garber .....	606/191	6,053,940 A	4/2000	Wijay .....	623/1
5,282,823 A	2/1994	Schwartz et al. ....	606/198	6,059,811 A	5/2000	Pinchasik et al. ....	606/198
5,282,824 A	2/1994	Gianturco .....	606/198	6,066,169 A	5/2000	McGuinness .....	623/1.16
5,290,305 A	3/1994	Inoue .....	606/191	6,068,656 A	5/2000	Von Oepen .....	623/1
5,292,331 A	3/1994	Boneau .....	606/198	6,083,259 A	7/2000	Franzen .....	623/1
5,314,472 A	5/1994	Fontaine .....	623/12	6,086,604 A	7/2000	Fischell et al. ....	606/198
5,316,023 A	5/1994	Palmaz et al. ....	128/898	6,090,127 A	7/2000	Globerman .....	606/194
5,342,387 A	8/1994	Summers .....	606/198	6,090,133 A	7/2000	Richter et al. ....	623/1
5,383,892 A	1/1995	Cardon et al. ....	606/198	6,099,455 A	8/2000	Columbo et al. ....	600/3
5,395,390 A	3/1995	Simon et al. ....	606/198	6,106,548 A	8/2000	Roubin et al. ....	623/1.15
5,405,377 A	4/1995	Cragg .....	623/1	6,114,049 A	9/2000	Richter .....	428/571
5,421,955 A	6/1995	Lau et al. ....	216/48	6,117,156 A	9/2000	Richter et al. ....	606/194
5,443,498 A	8/1995	Fontaine .....	623/1	6,117,165 A	9/2000	Becker .....	623/1
5,443,500 A	8/1995	Sigwart .....	623/1	6,123,721 A	9/2000	Jang .....	623/1
5,449,373 A *	9/1995	Pinchasik et al. ....	606/198	6,129,754 A	10/2000	Kanesaka et al. ....	623/1
5,458,615 A	10/1995	Klemm et al. ....	606/198	6,156,052 A	12/2000	Richter et al. ....	606/191
5,496,365 A	3/1996	Sgro .....	623/1	6,159,237 A	12/2000	Alt et al. ....	623/1.11
5,507,767 A	4/1996	Maeda et al. ....	606/198	6,171,334 B1	1/2001	Cox .....	623/1.15
5,507,771 A	4/1996	Gianturco .....	606/198	6,179,867 B1	1/2001	Cox .....	623/1.15
5,514,154 A	5/1996	Lau et al. ....	606/195	6,179,868 B1	1/2001	Burpee et al. ....	623/1.17
5,522,880 A	6/1996	Barone et al. ....	623/1	6,190,403 B1	2/2001	Fischell et al. ....	623/1
5,527,354 A	6/1996	Fontaine et al. ....	623/1	6,190,405 B1	2/2001	Culombo et al. ....	623/1.15
5,540,712 A	7/1996	Kleshinski .....	623/1	6,190,406 B1	2/2001	Duerig et al. ....	623/1.2
5,569,295 A	10/1996	Lam .....	606/198	6,193,744 B1	2/2001	Ehr et al. ....	623/1
5,575,817 A	11/1996	Martin .....	623/1	6,193,747 B1	2/2001	Von Oepen .....	623/1.15
5,591,197 A	1/1997	Orth et al. ....	606/198	6,197,048 B1	3/2001	Richter .....	623/1.15
5,603,721 A	2/1997	Lau et al. ....	606/195	6,200,334 B1	3/2001	Jang .....	623/1.1
5,607,442 A	3/1997	Fischell et al. ....	606/191	6,203,569 B1	3/2001	Wijay .....	623/1
5,623,771 A	4/1997	Winheim .....	34/585	6,231,598 B1	5/2001	Berry et al. ....	623/1.15
5,628,787 A	5/1997	Mayer .....	623/1	6,238,401 B1	5/2001	Richter .....	606/108
5,634,941 A	6/1997	Winston .....	623/12	6,251,133 B1	6/2001	Richter et al. ....	623/1.16
5,639,278 A	6/1997	Dereume .....	623/1	6,273,911 B1	8/2001	Cox et al. ....	623/1.15
5,643,312 A	7/1997	Fischell et al. ....	606/198	6,287,336 B1	9/2001	Globerman et al. ....	623/1.3
5,643,340 A	7/1997	Nunokawa .....	623/1	6,299,755 B1	10/2001	Richter .....	205/651
5,653,743 A	8/1997	Martin .....	623/1	6,315,794 B1	11/2001	Richter .....	623/1.34
5,674,278 A	10/1997	Boneau .....	623/1	6,355,059 B1	3/2002	Richter et al. ....	623/1.17
5,676,696 A	10/1997	Marcade .....	623/1	6,375,677 B1	4/2002	Penn et al. ....	623/1.16
5,676,697 A	10/1997	McDonald .....	623/1	6,547,817 B1	4/2003	Fischell et al. ....	623/1.16
5,693,086 A	12/1997	Goicoechea .....	623/1	2001/0000043 A1	3/2001	Israel et al. ....	606/198
5,697,971 A	12/1997	Fischell et al. ....	623/1	2001/0001317 A1	5/2001	Duerig et al. ....	623/1.15
5,709,713 A	1/1998	Evans et al. ....	623/1	2002/0052646 A1	5/2002	Fischell et al. ....	623/1.15
				2003/0114868 A1	6/2003	Fischell et al. ....	606/159



FOREIGN PATENT DOCUMENTS

CA	2171047	9/1997	.....	A61F/2/06
CA	2175722	11/1997	.....	A61F/2/04
CA	2185740	3/1998	.....	A61F/2/06
DE	295 16712 U1	8/1996	.....	F16S/3/08
EP	0 045 627	10/1982	.....	F16L/13/00
EP	0 505 686 A1	9/1992	.....	A61F/2/06
EP	0566807	10/1993		
EP	0 669 114 A1	8/1995		
EP	0 709 067 A2	5/1996		
FR	2678508	7/1991		
JP	6-41745	6/1994	.....	A61M/29/02
WO	WO94/12136	6/1994		
WO	WO95/09584	4/1995		
WO	WO95/31945	2/1996		
WO	WO 96/02295 A1	2/1996	.....	A61M/29/02
WO	WO96/03092	2/1996		
WO	WO 9603092 A1	2/1996		
WO	WO 96/14028	5/1996	.....	A61F/2/06
WO	WO97/04721	2/1997		
WO	WO 97/32543	9/1997	.....	A61F/2/06
WO	WO 97/32544	9/1997	.....	A61F/2/06
WO	WO 97/33532	9/1997		
WO	WO 98/22159 A3	5/1998	.....	A61F/2/03
WO	WO 98/33546	8/1998		
WO	WO 00/28922	5/2000		
WO	WO 00/49971	8/2000		
WO	WO 00/53122	9/2000		
WO	WO 01/00112 A1	1/2001		
WO	WO 01/15632 A1	3/2001		

OTHER PUBLICATIONS

Mirich et al., "Percutaneously Placed Endovascular Grafts for Aortic Aneurysms: Feasibility Study," *RADIOLOGY*, vol. 170, pp. 1033-1037 (1989).

Fallone et al., "Elastic Characteristics of the Self-Expanding Metallic Stents," *Investigative Radiology*, vol. 23, pp. 370-376 (May 1988).

Charnsangavej et al., "Stenosis of the Vena Cava: Preliminary Assessment of Treatment with Expandable Metallic Stents," *RADIOLOGY*, 1986 161:295-98.

Rösch et al., "Gianturco Expandable Stents in Experimental and Clinical Use," Mar. 24, 1987, pp. 121-124.

Wallace et al., "Tracheobronchial Tree: Expandable Metallic Stents Used in Experimental and Clinical Applications—Work in Progress," *RADIOLOGY* 158:309-12 (1986).

Rösch et al., "Experimental Intrahepatic Protacaval Anastomosis: Use of Expandable Gianturco Stents," *RADIOLOGY*, 162:481-85 (1987).

Rösch et al., "Modified Gianturco Expandable Wire Stents in Experimental and Clinical Use," *Ann Radiol.*, 31:100-03 (1988).

Charnsangavej et al., "A New Expandable Metallic Stent for Dilatation of Stenotic Tubular Structures: Experimental and Clinical Evaluation," *Houston Medical Journal*, vol. 3, Jun. 1987, pp. 41-51.

Rösch et al., "Gianturco Expandable Wire Stents in the Treatment of Superior Vena Cava Syndrome Recurring After Maximum-Tolerance Radiation," *CANCER*, 60:1243-46 (1987).

Yoshioka et al., "Self-Expanding Endovascular Graft: An Experimental Study in Dogs," *AJR*, 151:673-76 (1988).

Simonds et al., "Use of Expandable Metal Stents in the Treatment of Bronchial Obstruction," *THORAX*, 44:680-81 (1989).

Duprat et al., "Flexible Balloon-Expanded Stent for Small Vessels—Work in Progress," *RADIOLOGY*, 162:276-78 (1987).

\* cited by examiner

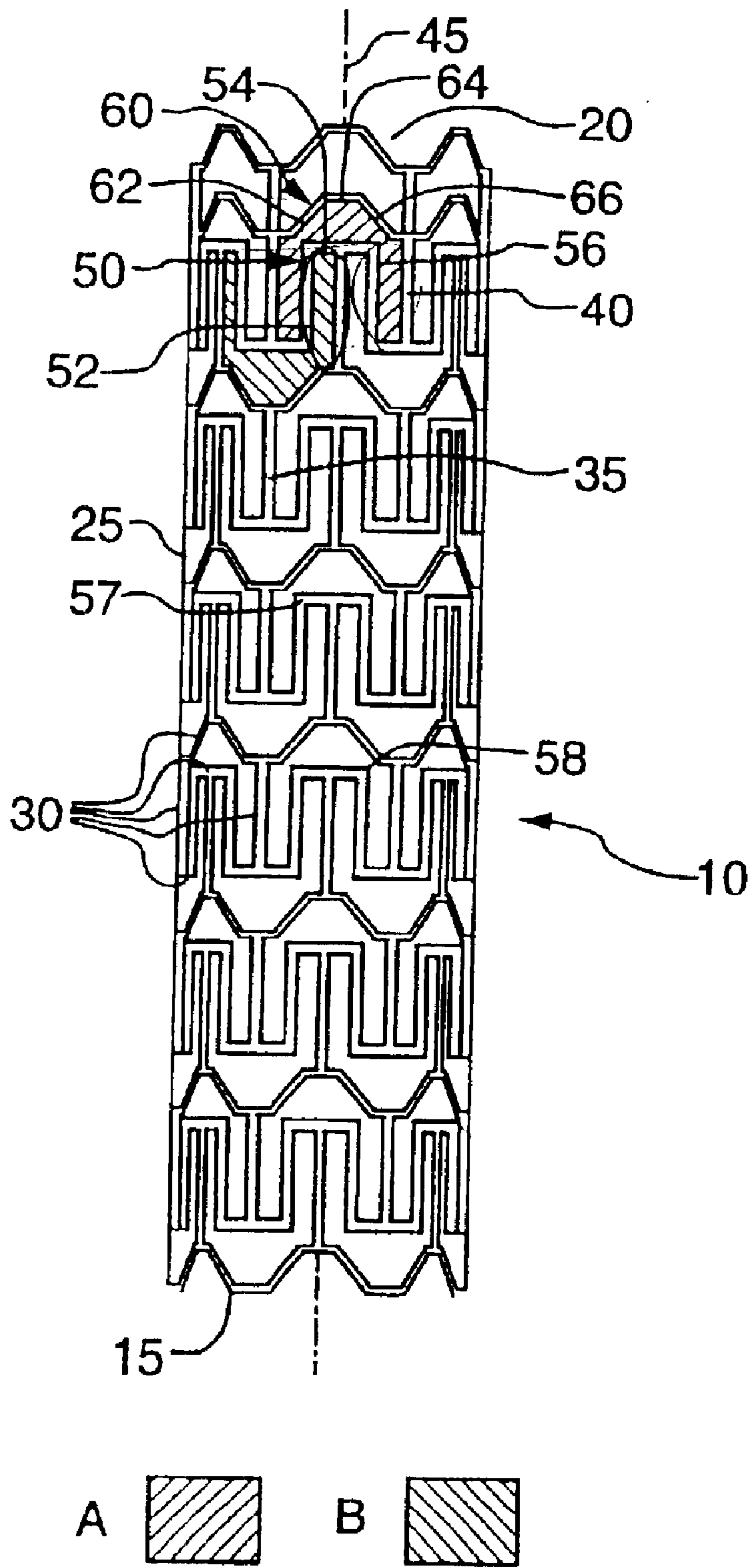

FIG.1

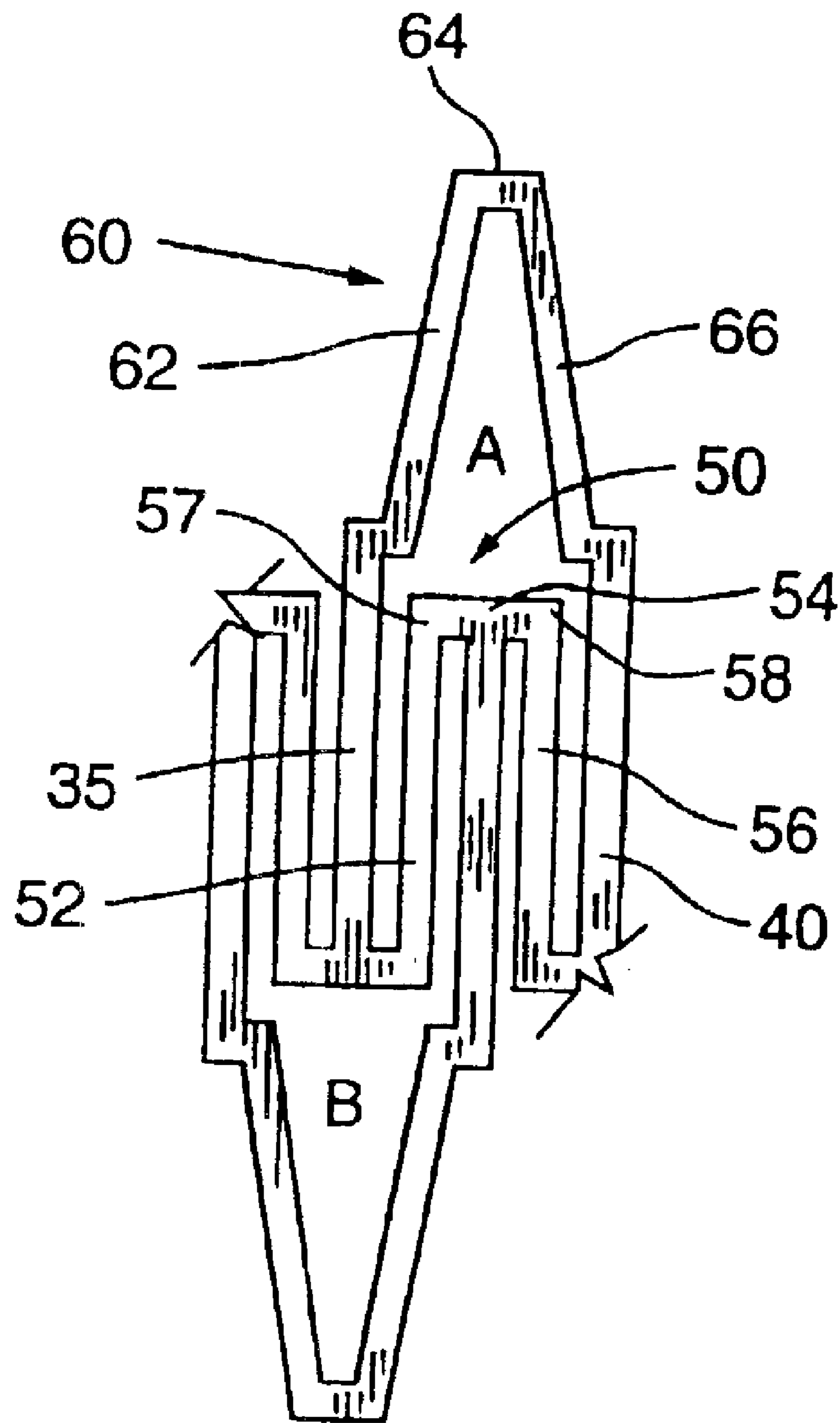

FIG. 1A

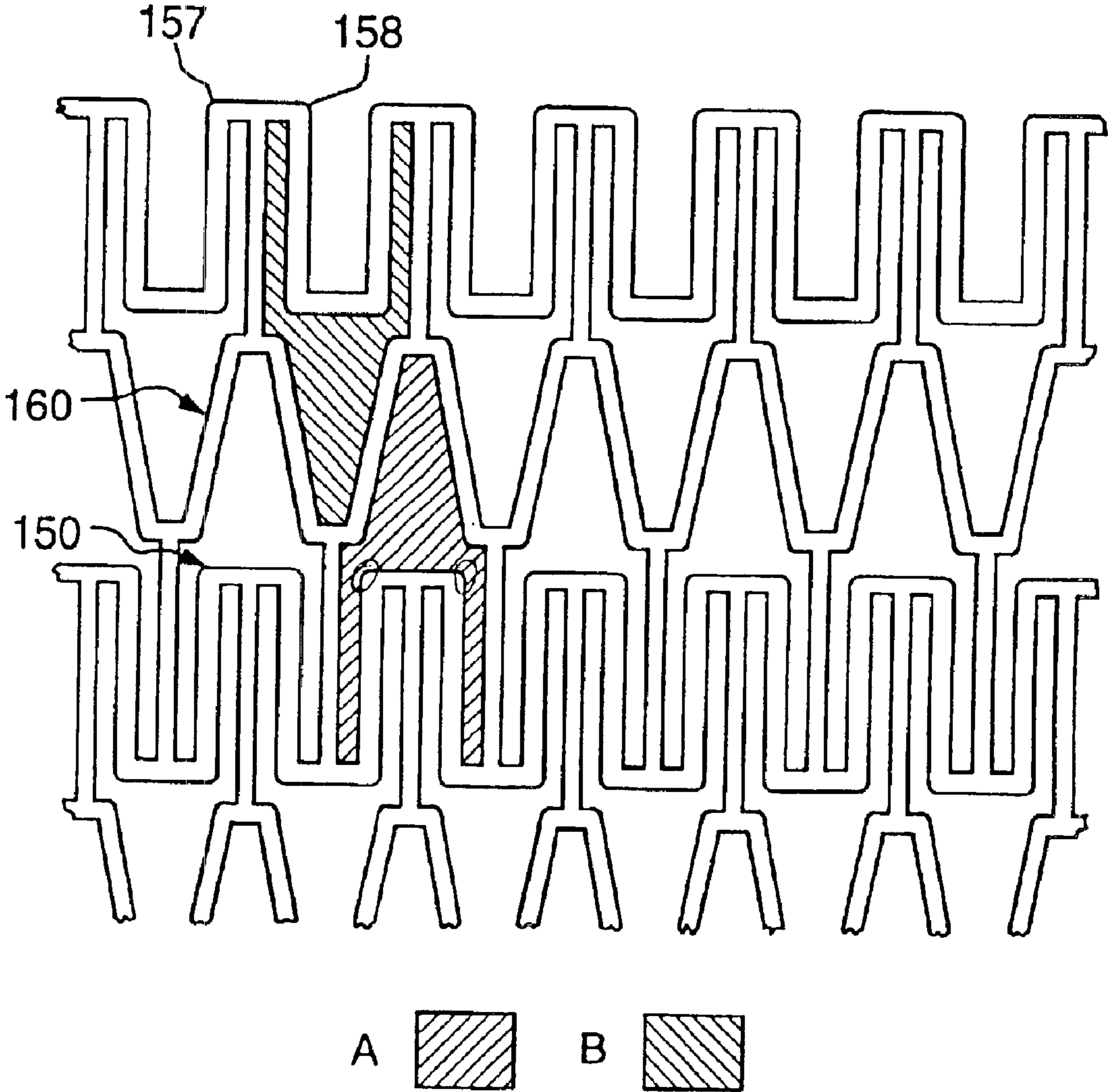

FIG.2

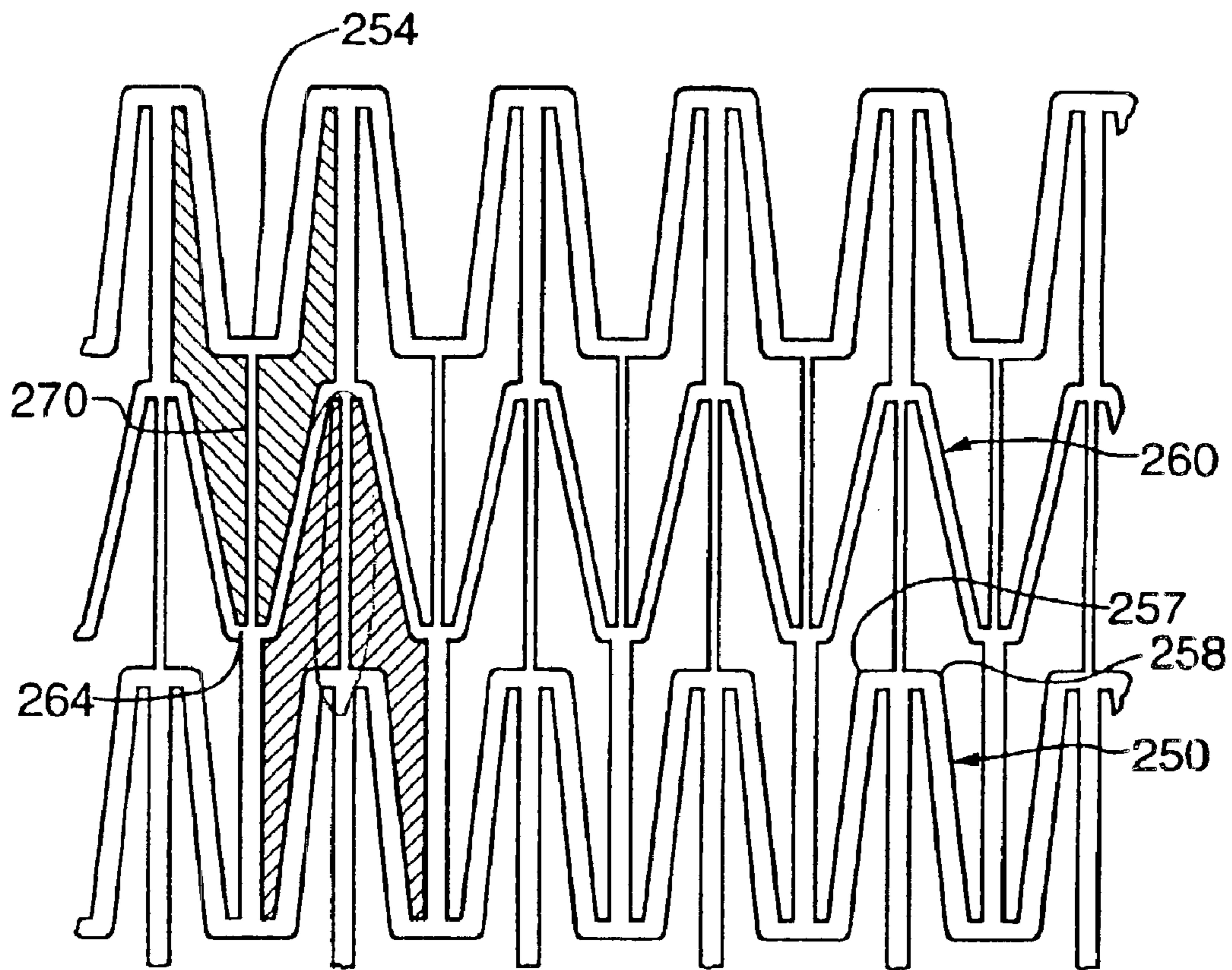

FIG.3



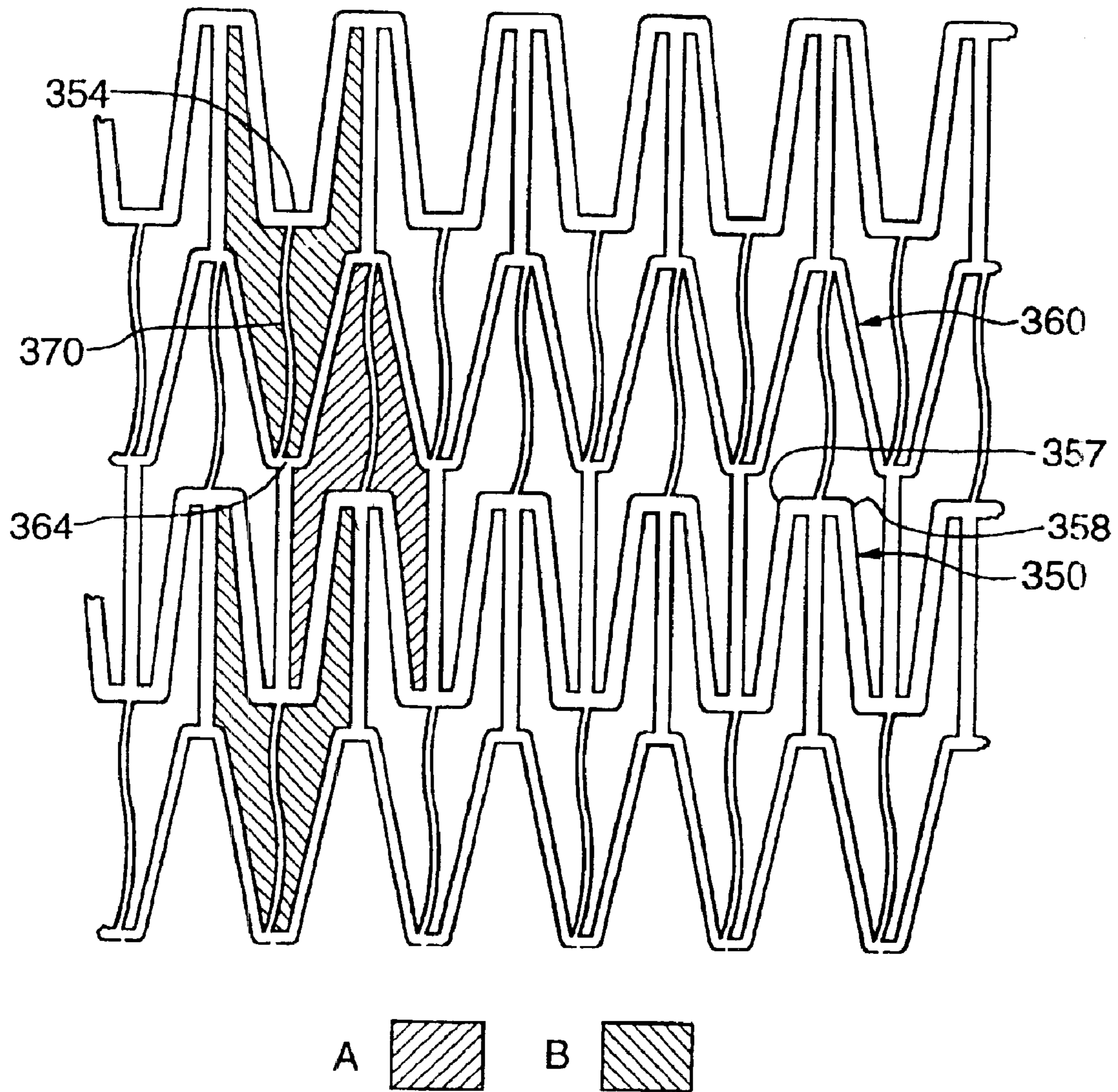

FIG.4



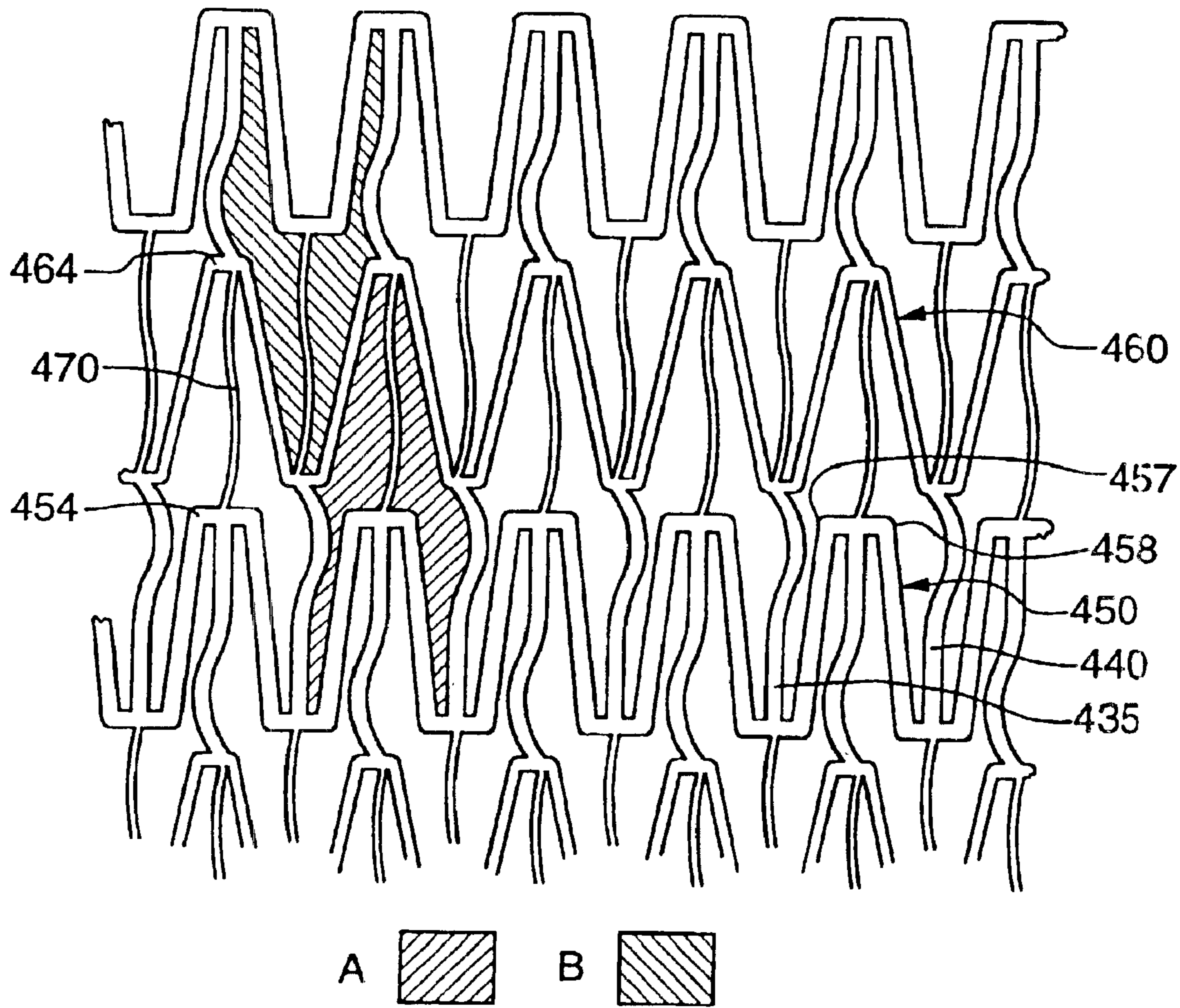

FIG.5

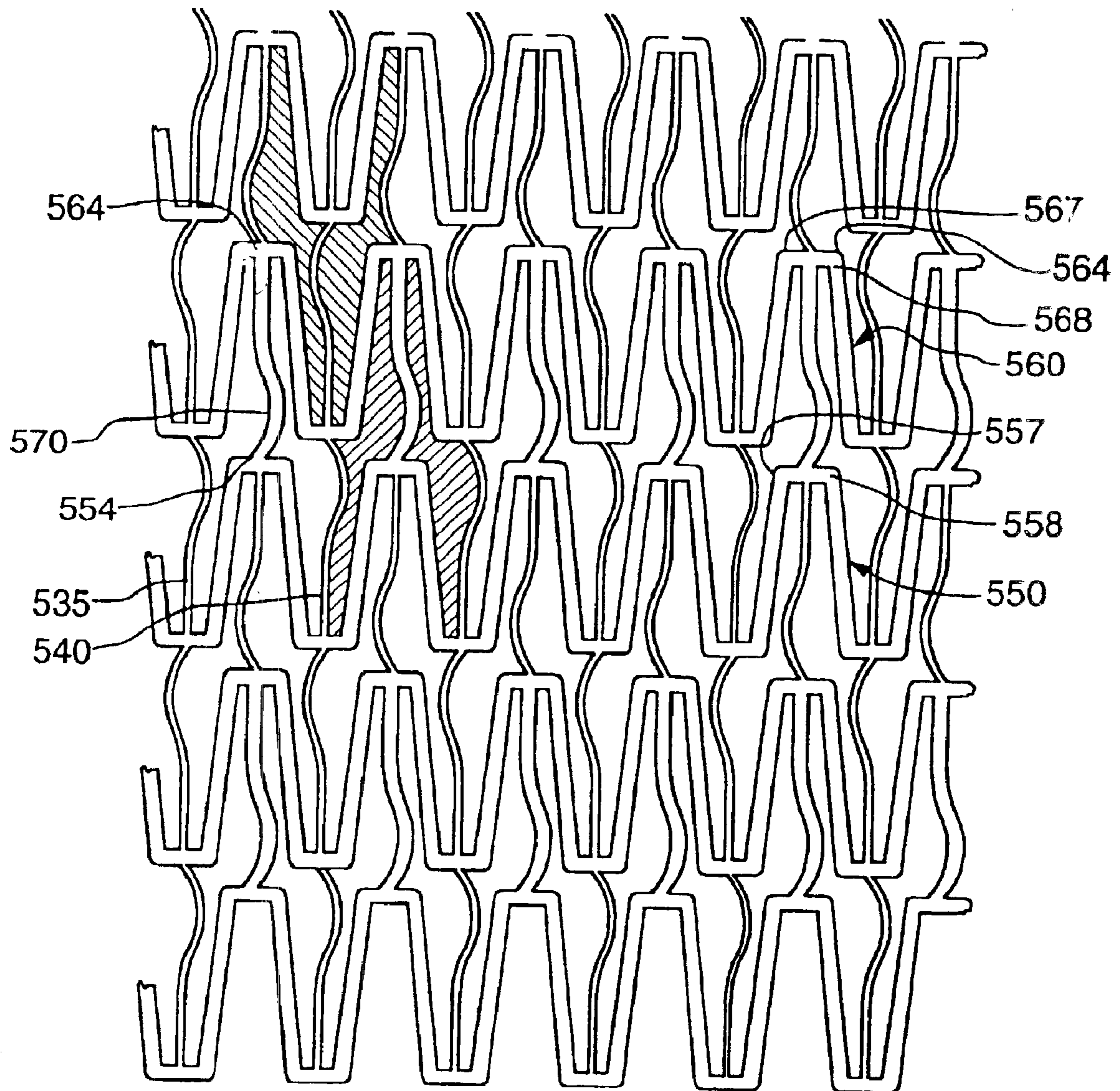

FIG.6

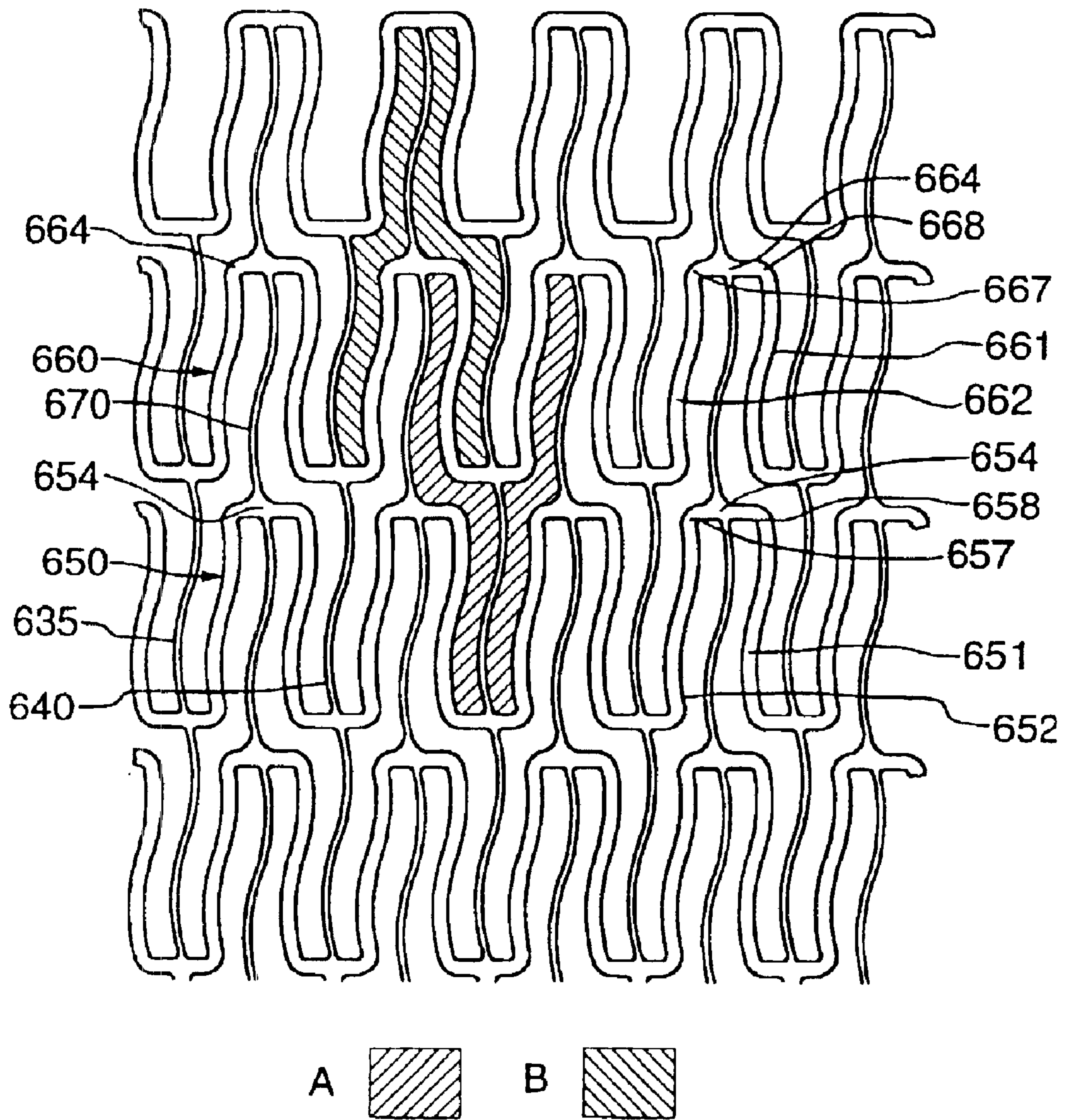

FIG.7



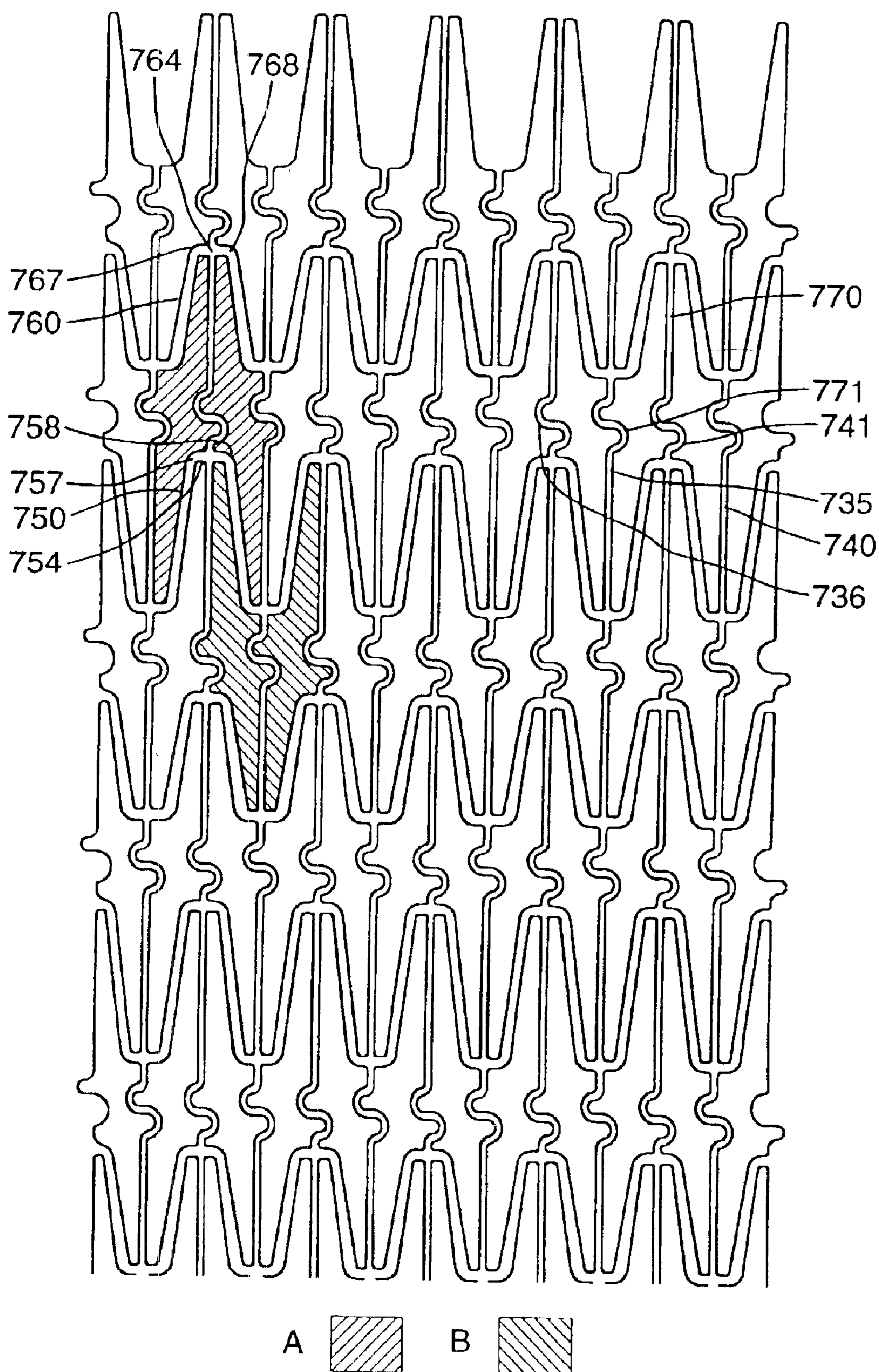

FIG.8

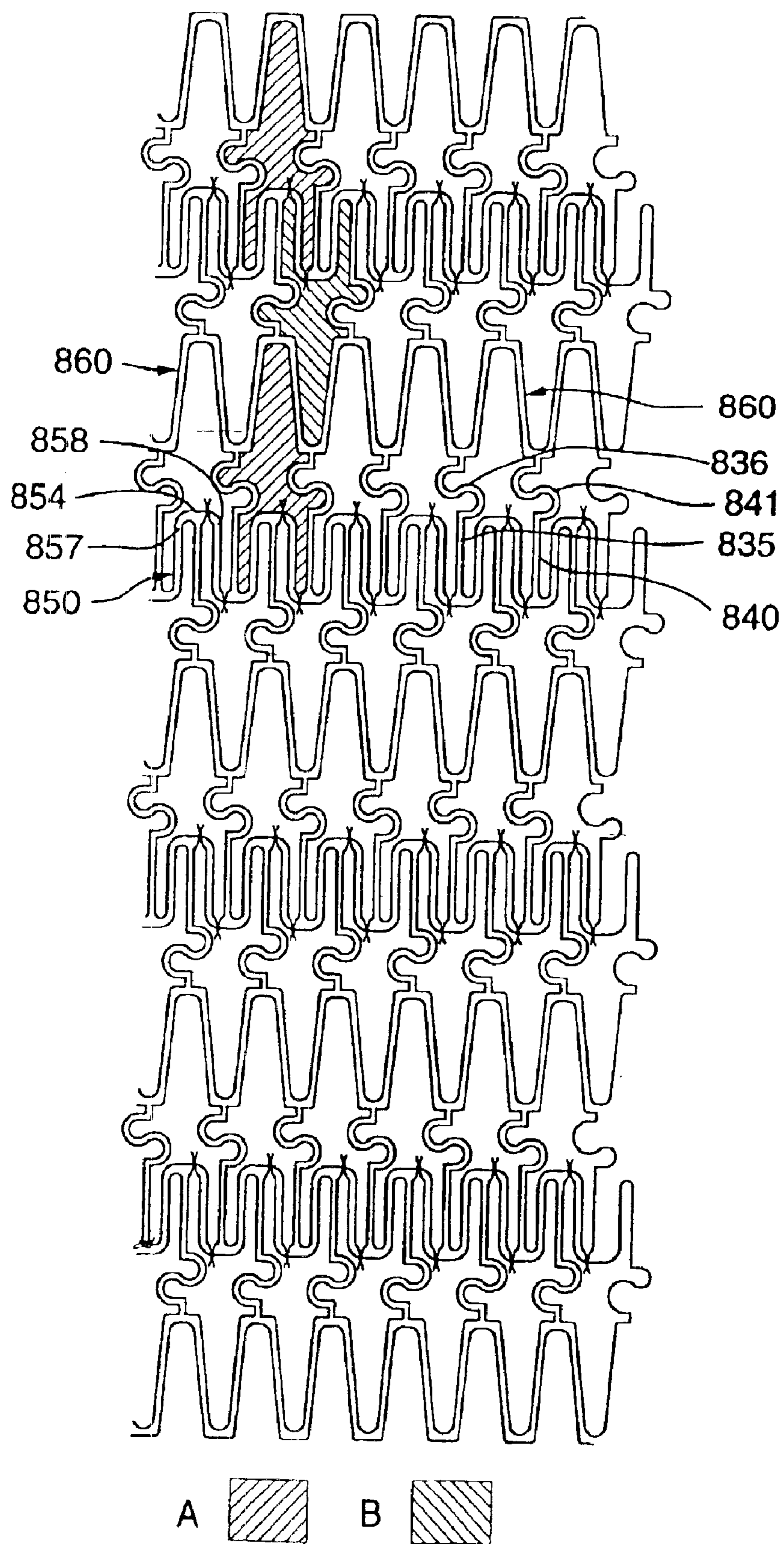

FIG.9

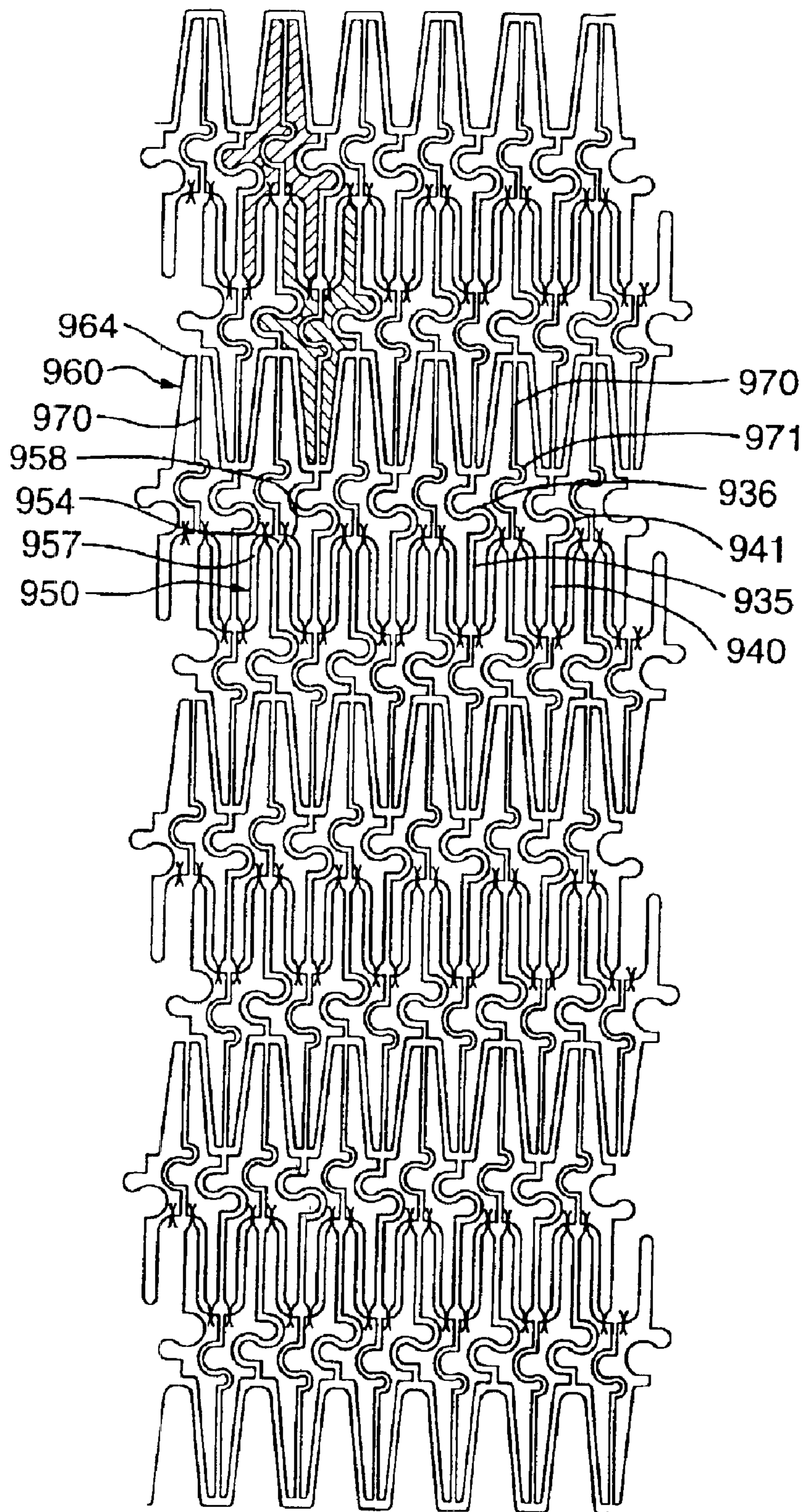

FIG. 10



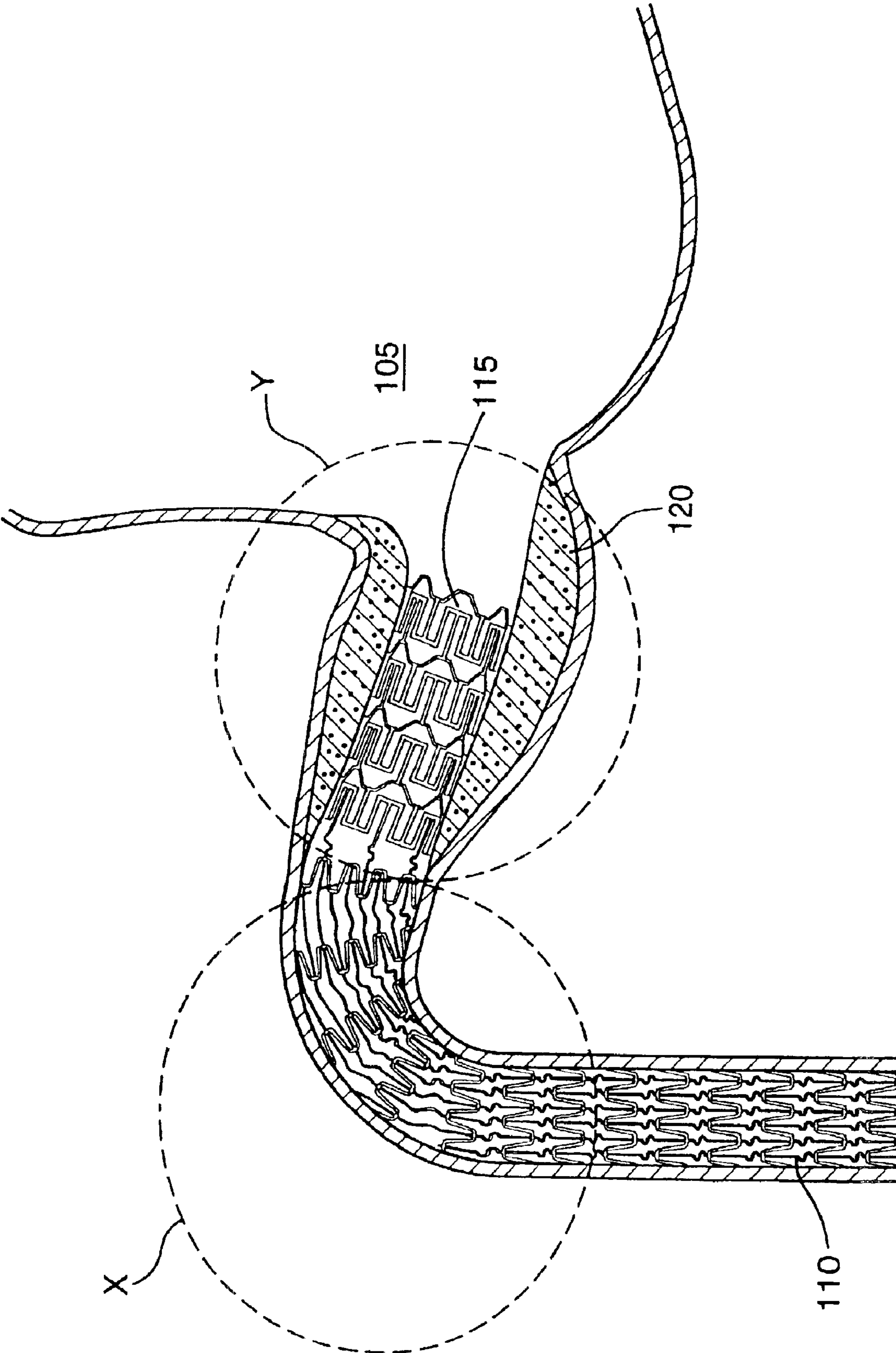

FIG.11

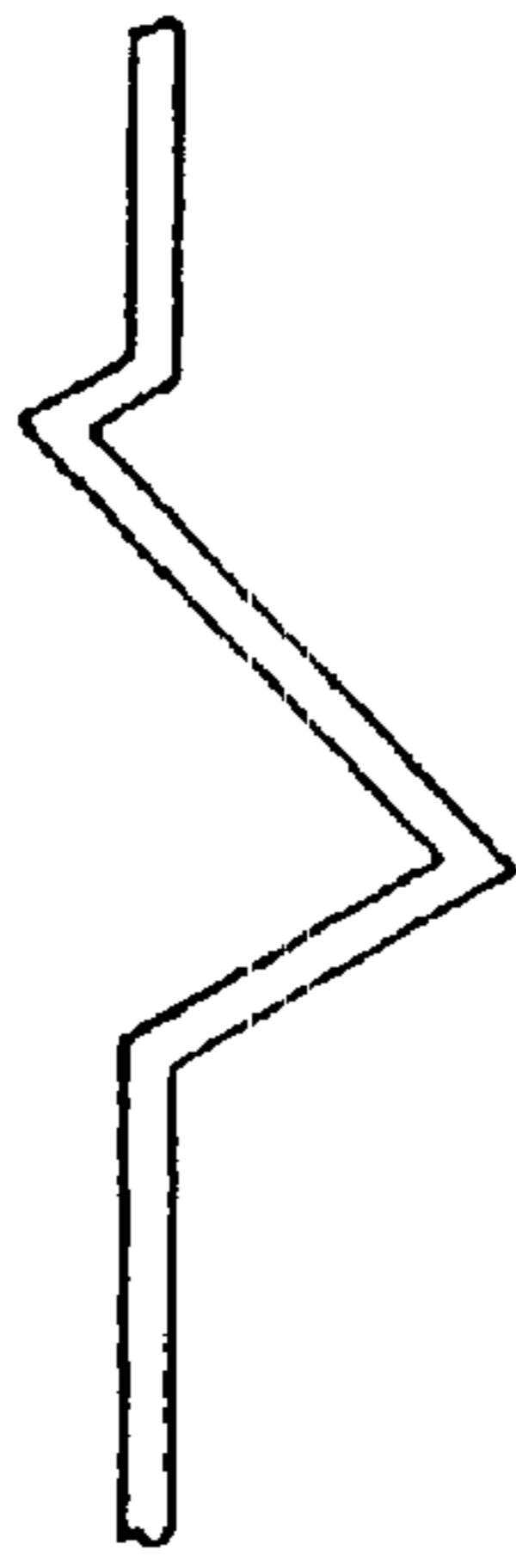

FIG. 12a.

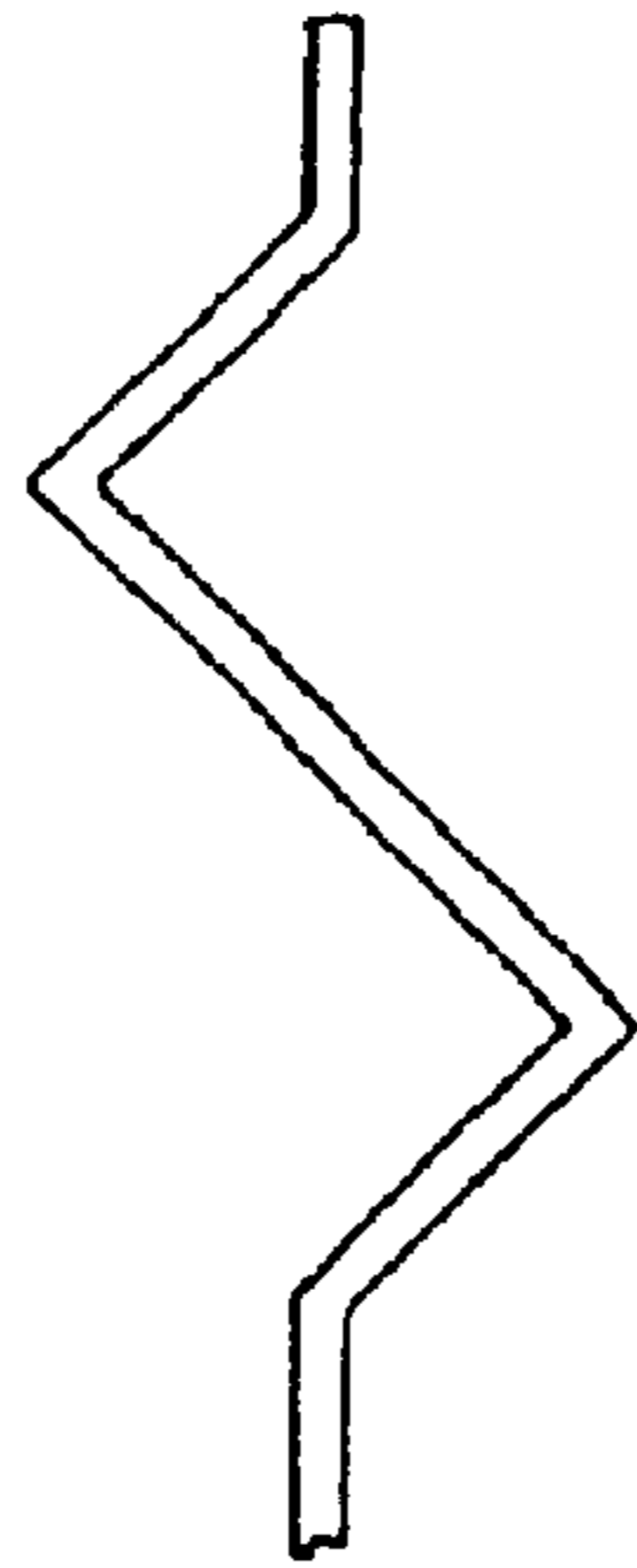

FIG. 12b.

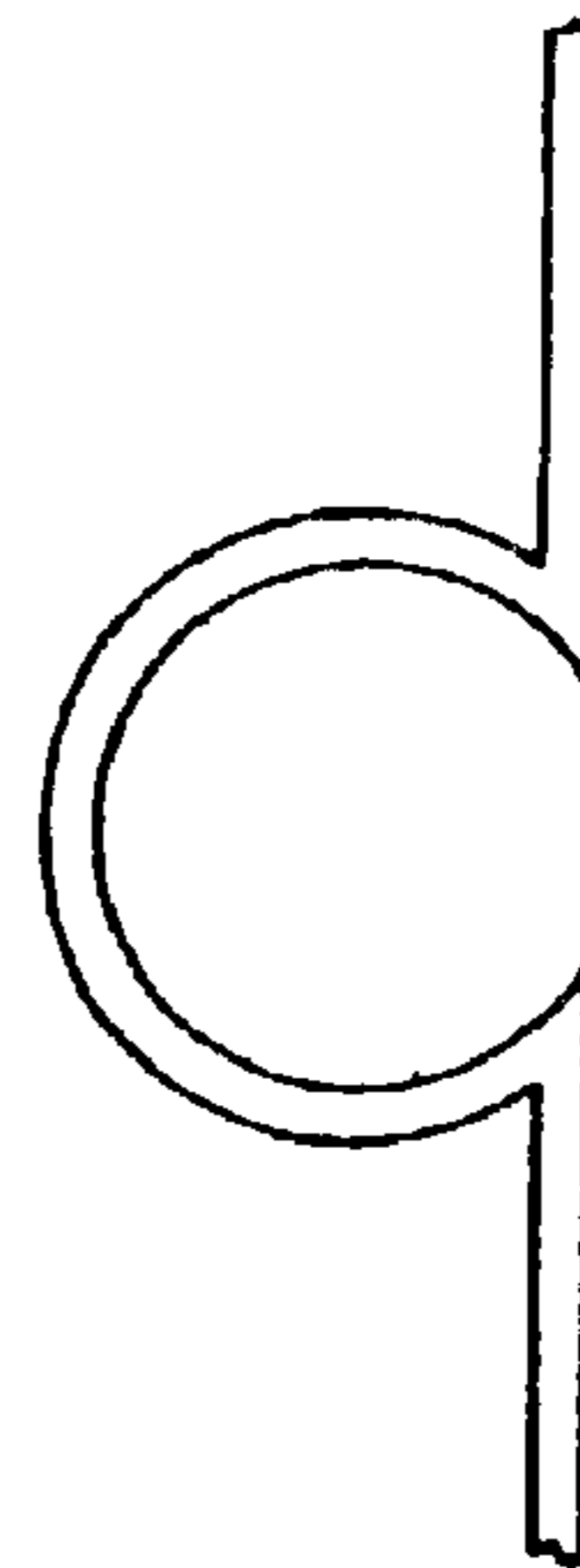

FIG. 12d.

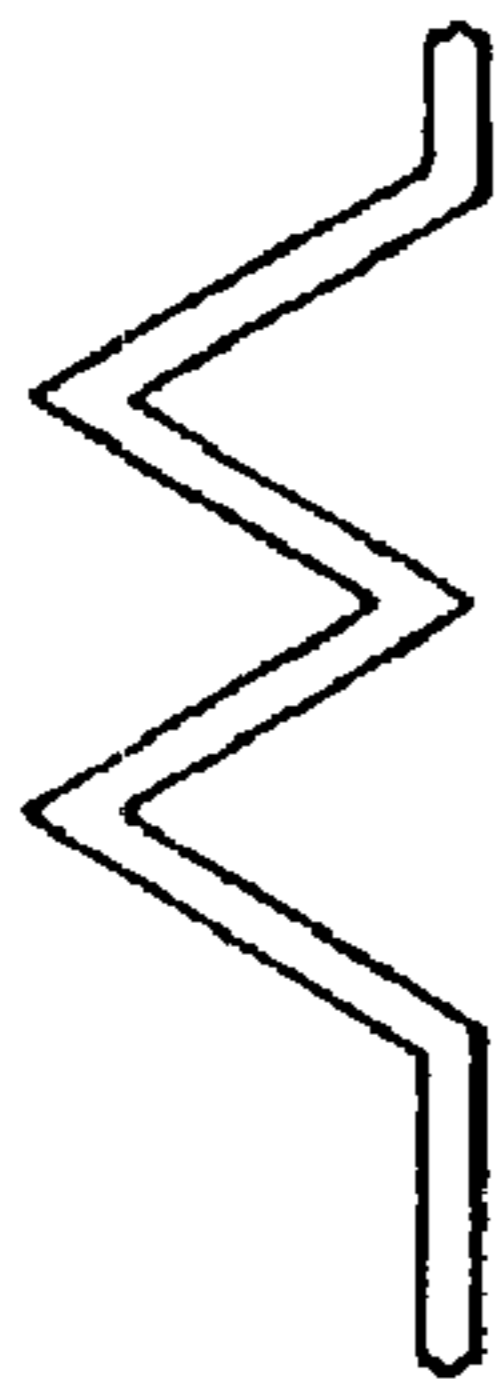

FIG. 12c.

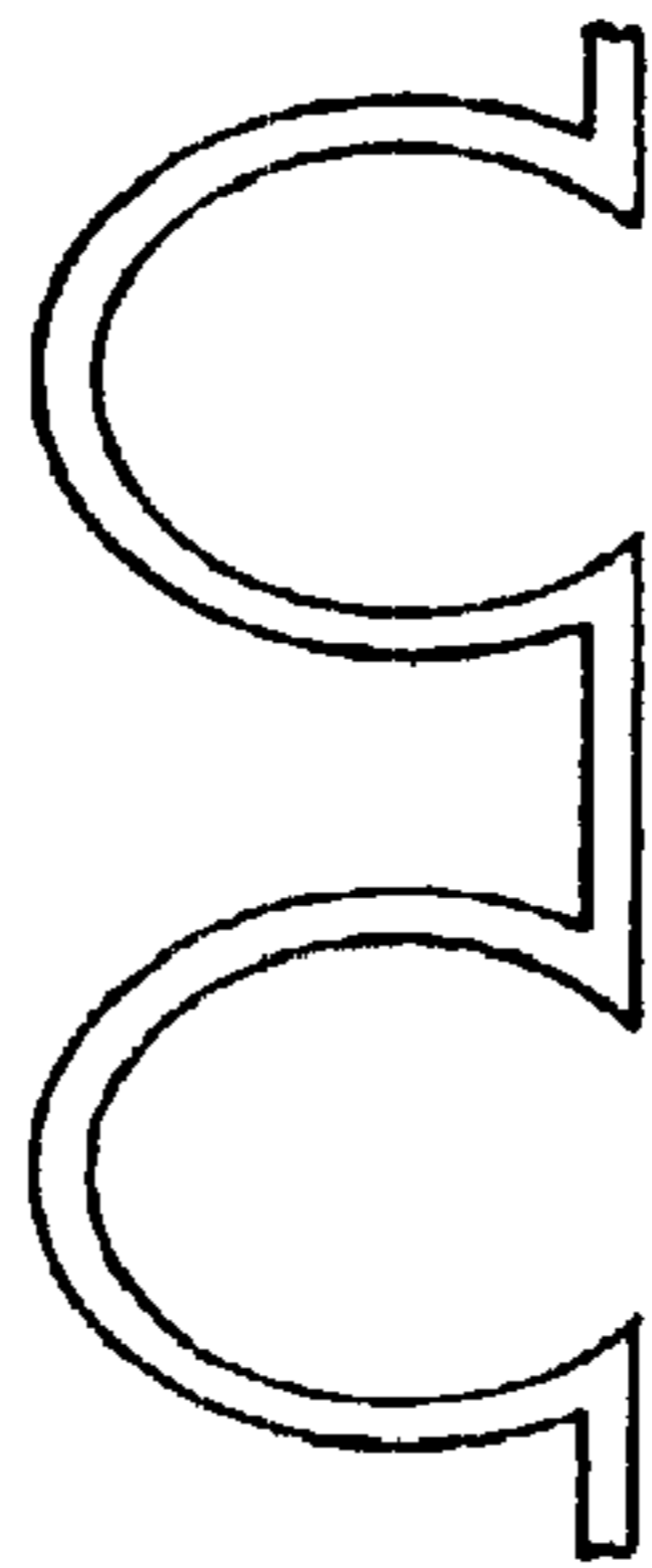

FIG. 12e.

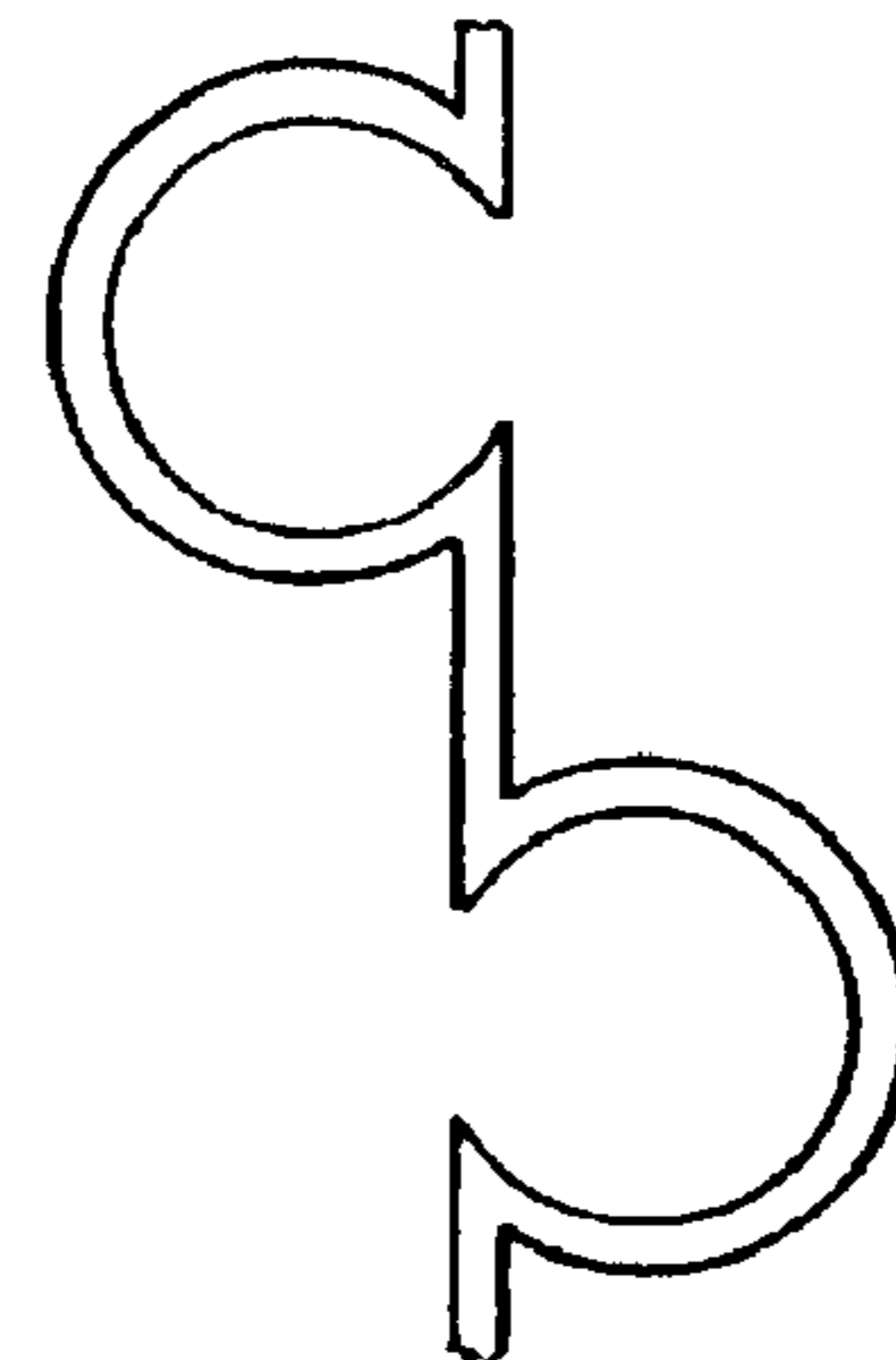

FIG. 12f.

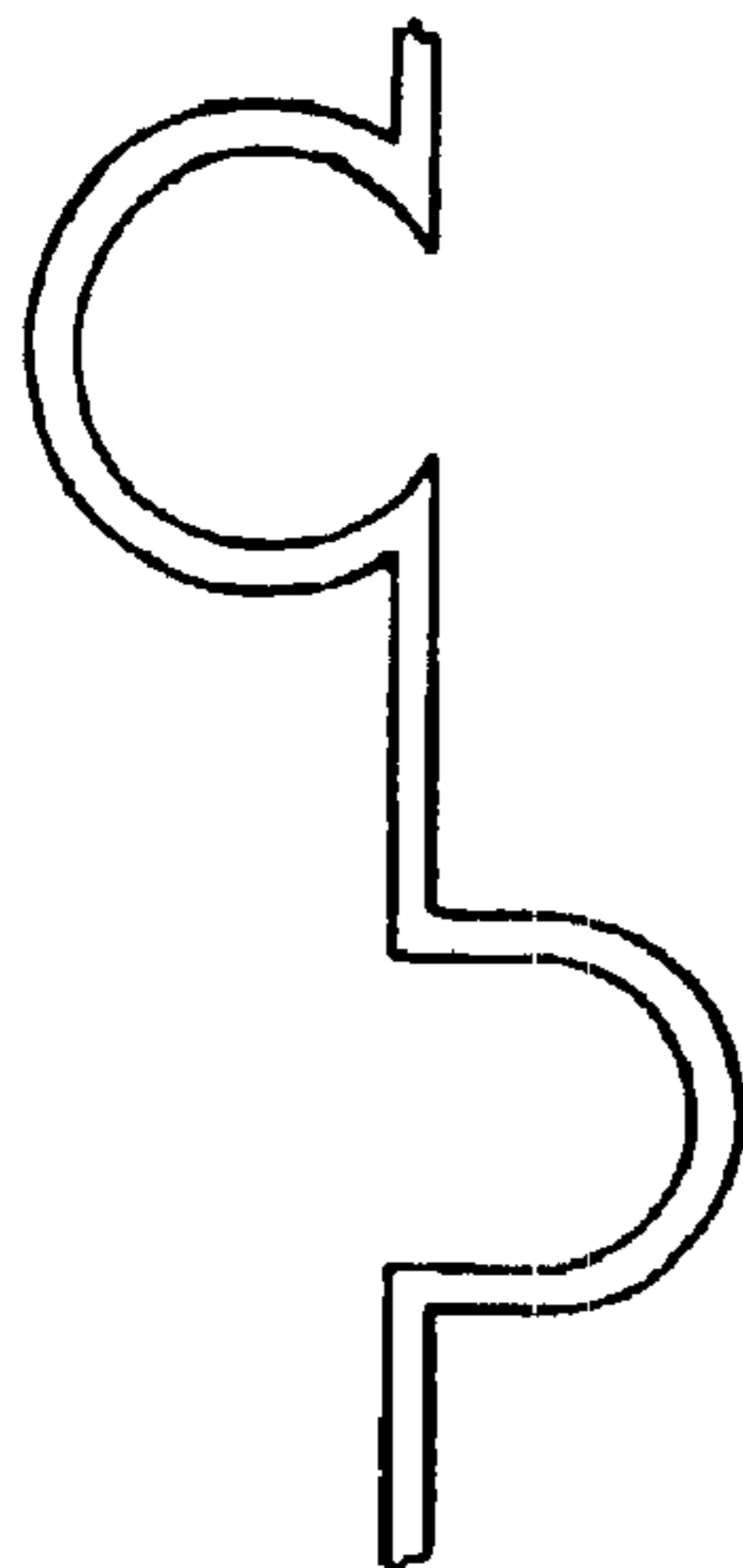

FIG. 12g.

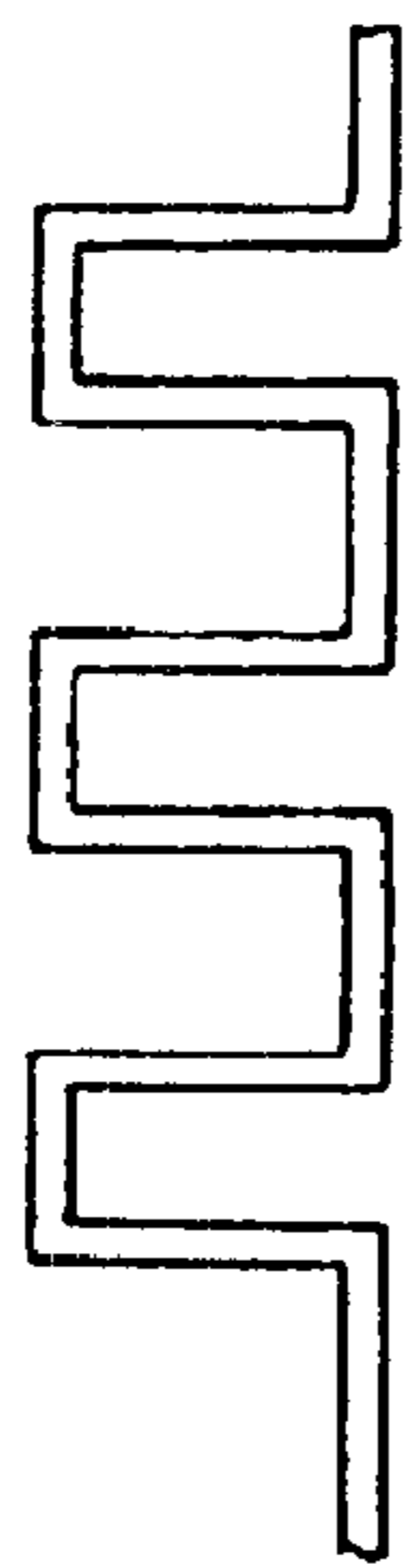

FIG. 12h.

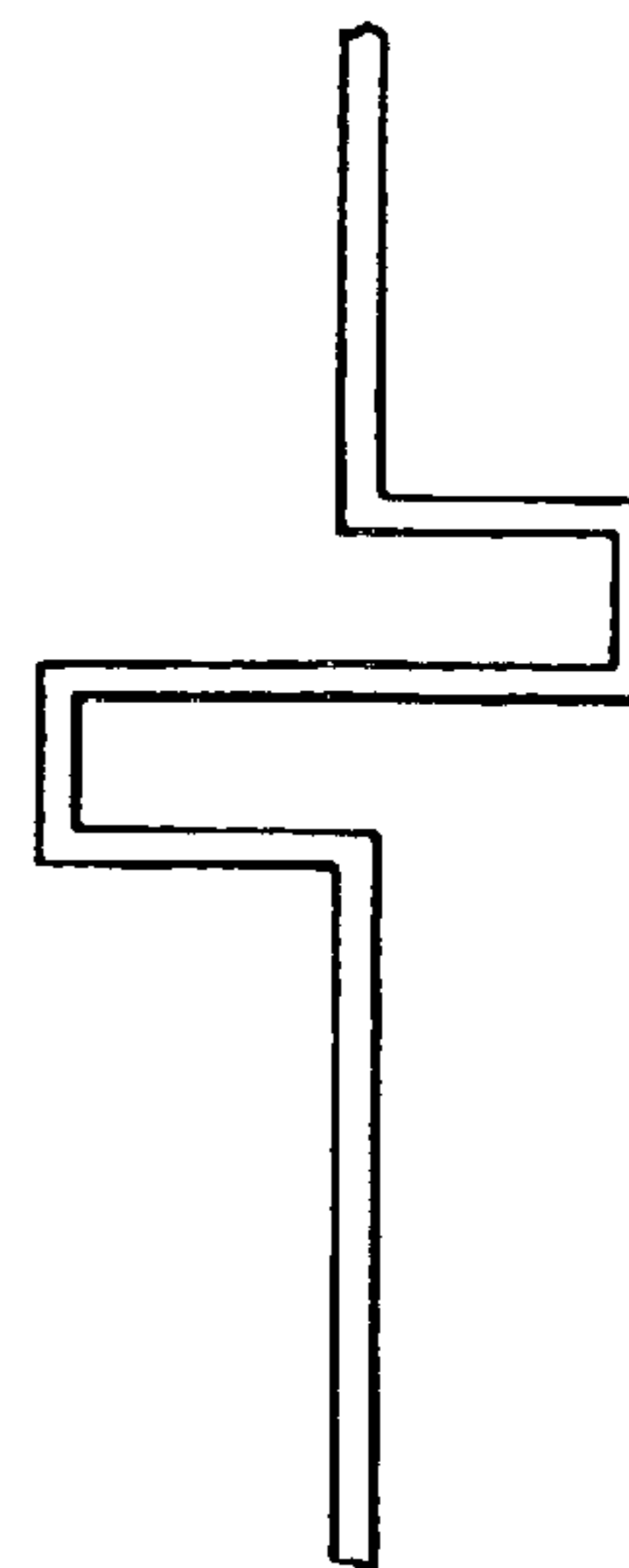

FIG. 12i.



## EXPANDABLE STENT AND METHOD FOR DELIVERY OF SAME

### TECHNICAL FIELD

This application is a continuation of U.S. patent application Ser. No. 10/073,277, filed Feb. 13, 2002, which is a continuation of U.S. patent application Ser. No. 09/672,767, filed Sep. 29, 2000, now U.S. Pat. No. 6,375,677, issued Apr. 23, 2002, which is a continuation of U.S. patent application Ser. No. 09/142,508, filed Feb. 16, 1999, now U.S. Pat. No. 6,217,608, issued Apr. 17, 2001, which is a U.S. National Phase under 35 U.S.C. §371 of PCT/CA97/00151, filed Mar. 5, 1997 (designating the U.S.; and which published in English in WO 97/32543 on Sep. 12, 1997), which claims the benefit of Canadian Patent No. 2,171,047, filed Mar. 5, 1996, Canadian Patent No. 2,175,722, filed May 3, 1996, Canadian Patent No. 2,185,740, filed Sep. 17, 1996, and Canadian Patent No. 2,192,520, filed Dec. 10, 1996. The contents of all of the U.S. Patent Applications are incorporated herein by reference in their entirety.

### BACKGROUND ART

Stents are generally known. Indeed, the term "stent" has been used interchangeably with terms such as "intraluminal vascular graft" and "expandable prosthesis". As used throughout this specification the term "stent" is intended to have a broad meaning and encompasses any expandable prosthetic device for implantation in a body passageway (e.g. a lumen or artery).

In the past six to eight years, the use of stents has attracted an increasing amount of attention due the potential of these devices to be used, in certain cases, as an alternative to surgery. Generally, a stent is used to obtain and maintain the patency of the body passageway while maintaining the integrity of the passageway. As used in this specification, the term "body passageway" is intended to have a broad meaning and encompasses any duct (e.g. natural or iatrogenic) within the human body and can include a member selected from the group comprising: blood vessels, respiratory ducts, gastrointestinal ducts and the like.

Initial stents were self-expanding, spring-like devices which were inserted in the body passageway in a contracted state. When released, the stent would automatically expand and increase to a final diameter dependent on the size of the stent and the elasticity of the body passageway. An example of such a stent is known in the art as the Wallstent™.

The self-expanding stents were found by some investigators to be deficient since, when deployed, they could place undue, permanent stress on the walls of the body passageway. Further, upon expansion, the stent would shorten in length in an unpredictable fashion thereby reducing the reliability of the stent. This led to the development of various stents which were controllably expandable at the target body passageway so that only sufficient force to maintain the patency of the body passageway was applied in expanding the stent

Generally, in these later systems, a stent, in association with a balloon, is delivered to the target area of the body passageway by a catheter system. Once the stent has been properly located (for example, for intravascular implantation the target area of the vessel can be filled with a contrast medium to facilitate visualization during fluoroscopy), the balloon is expanded thereby expanding the stent by plastic deformation so that the latter is urged in place against the body passageway. As indicated above, the amount of force applied is at least that necessary to maintain the patency of

the body passageway. At this point, the balloon is deflated and withdrawn within the catheter, and subsequently removed. Ideally, the stent will remain in place and maintain the target area of the body passageway substantially free of blockage (or narrowing).

A stent which has gained some notoriety in the art is known as the Palmaz-Schatz™ Balloon Expandable Stent (hereinafter referred to as "the Palmaz-Schatz stent"). This stent is discussed in a number of patents including U.S. Pat. Nos. 4,733,665, 4,739,762, 5,102,417 and 5,316,023, the contents of each of which are hereby incorporated by reference.

Another stent which has gained some notoriety in the art is known as the Gianturco-Roubin Flex-Stent™ (hereinafter referred to as "the Gianturco-Roubin stent"). This stent is discussed in a number of patents, including U.S. Pat. Nos. 4,800,882, 4,907,336 and 5,041,126, the contents of each of which are hereby incorporated by reference.

Other types of stents are disclosed in the following patents:

U.S. Pat. No. 5,035,706 (Gianturco et al.),

U.S. Pat. No. 5,037,392 (Hillstead),

U.S. Pat. No. 5,147,385 (Beck et al.),

U.S. Pat. No. 5,282,824 (Gianturco),

Canadian patent 1,239,755 (Wallsten), and

Canadian patent 1,245,527 (Gianturco et al.),

the contents of each of which are hereby incorporated by reference.

While these prior art stents have achieved a varying degree of success, the art is constantly in need of new stents having improved flexibility and stability while being able to be readily implanted with little or no trauma to the target lumen.

In our Canadian patent application number 2,134,997 (Penn et al.), the contents of which are hereby incorporated by reference, there is described an improved expandable stent. The stent comprises a tubular wall disposed between the proximal end and the distal end. The tubular wall has a longitudinal axis and a porous surface defined by a plurality intersecting members arranged to define a first repeating pattern. The first repeating pattern comprises a polygon having a pair of side walls substantially parallel to the longitudinal axis. A first concave-shaped wall and a second convex-shaped wall connect the side walls. The first wall and the second wall are equidistant along an axis which is parallel to the longitudinal axis. The stent is expandable from a first, contracted position to a second, expanded position upon the application of a radially outward force exerted on the stent.

As disclosed in the '997 application, the first repeating pattern can be implemented in, inter alia, a mono-tubular expandable stent and a bifurcated expandable stent.

While the stent disclosed in the '997 application is an advance in the art, in certain cases, a significant force is required to achieve expansion in the target body passageway. Further, implantation of the stent disclosed in the '997 application can be difficult in certain situations where the unexpanded stent must travel through a significantly curved pathway to the target body passageway.

Accordingly, it would be desirable to have an improved stent which overcomes these disadvantages. It would be further desirable if the improved stent could be readily adapted, inter alia, to mono-tubular expandable stents and bifurcated expandable stents. The latter type of stents would be useful in treating aneurysms, blockages and other ailments. It would also be desirable if such a stent was



relatively easy to implant. It would be further desirable if such a stent were capable of being uniformly expanded at relatively low pressure while obviating or mitigating longitudinal shrinkage thereof. It would be further desirable if such a stent were not susceptible to asymmetric internal coverage of the body passageway, a problem associated with “coil”-type stents—see, for example, U.S. Pat. No. 5,282,824 (Gianturco). It would be further desirable if such a stent was not susceptible to movement along the longitudinal axis of the body passageway during or after implantation. It would be further desirable if such a stent was characterized by a desirable balance of lateral flexibility in the unexpanded state and radial rigidity in the expanded state.

#### DISCLOSURE OF THE INVENTION

It is an object of the present invention to provide a novel expandable stent which obviates or mitigates at least one of the above-mentioned disadvantages of the prior art.

Accordingly, in one of its aspects, the present invention provides an expandable stent comprising a proximal end and a distal end in communication with one another, a tubular wall disposed between the proximal end and the distal end, the tubular wall having a longitudinal axis and a porous surface defined by a plurality of intersecting members comprising a series of longitudinal struts disposed substantially parallel to the longitudinal axis of the stent, each of the longitudinal struts comprising flexure means for substantially complementary extension and compression of a diametrically opposed pair of the longitudinal struts upon flexure of the stent, the stent being expandable from a first, contracted position to a second, expanded position upon the application of a radially outward force on the stent.

Thus, in this aspect of the present invention, we have now discovered that the use of flexure means in the series of longitudinal struts leads to a very desirable balance of lateral flexibility of the unexpanded stent and radial rigidity of the expanded stent. Practically, the flexure means confers lateral flexibility to the unexpanded stent by allowing diametrically opposed pairs of the longitudinal struts to undergo substantially complementary extension and compression. If one considers a stent in a flexed state, a first longitudinal strut disposed at the tangent of the bend (i.e. in two dimensions) will expand in response to the bending moment. In contrast, a second longitudinal strut disposed diametrically opposite (this can mean above, below or in the same radial plane as) the first longitudinal strut will compress in response to the bending moment. Generally, the degree of extension and compression will be substantially complementary. In other words, in most cases, the first longitudinal strut will expand and lengthen a first distance and the second longitudinal strut will compress and shorten a second distance. Preferably, the first distance is greater than the second distance and most preferably, the sum of the first distance and the second distance is substantially equal to the sum of the original lengths of the first longitudinal strut and the second longitudinal strut.

The specific shape of the flexure means disposed in the longitudinal strut is not particularly restricted provided that it confers lateral flexibility to the unexpanded stent by allowing diametrically opposed pairs of the longitudinal struts to undergo substantially complementary extension and compression. The term “diametrically opposed pairs of the longitudinal struts”, as used in this specification, is intended to have a broad meaning. Thus, the “pair” can include opposed struts in the same horizontal plane (i.e. the same ring of polygons) or in different horizontal planes (e.g. one

strut in a first ring of polygons and the other diametrically opposed strut in a second ring of polygons above or below the first ring). Preferably, the flexure means comprises at least one lateral section disposed in the longitudinal strut, more preferably at least a first lateral section and a second lateral section disposed in the longitudinal strut. By “lateral section” is meant a section of the longitudinal strut which is bowed in or out of (i.e. radially from) the strut. The apex of the lateral section may be pointed, rounded or substantially flat. When the flexure means comprises a first lateral section and a second lateral section, the two sections may be symmetric or asymmetric (in the case of asymmetric this includes two sections of the same shape but different size and two sections of different and size). Further, when the flexure means comprises a first lateral section and a section lateral section, the sections may be bowed in the same or opposite direction.

A particularly preferred embodiment of the flexure means comprises a sinusoidal or S-shaped section (various examples of such a section are illustrated herein and discussed below). Preferably, the sinusoidal or S-shaped section is adjacent the second apex of the polygon and the remaining portion of the strut is substantially straight. This feature improves the lateral flexibility of the stent thereby facilitating implantation thereof and may further mitigate longitudinal shortening of the stent upon expansion.

In another preferred embodiment, at least one, more preferably both, of the side walls (i.e. longitudinal struts) of the polygon comprises the sinusoidal or S-shaped section. Preferably, the sinusoidal or S-shaped section is disposed at an end of the side wall. This feature improves the lateral flexibility of the stent thereby facilitating implantation thereof and may further mitigate longitudinal shortening of the stent upon expansion.

When a sinusoidal or S-shaped portion is disposed in the side walls and/or the strut connecting the first apex and the second apex (if present), the precise shape of the portion is not particularly restricted and generally takes the form of an “S”. Thus, the sinusoidal or S-shaped portion may be comprised of a pair of joined curved sections wherein each curved section has an arc of about 180°—i.e. this is illustrated in FIG. 8 of the present application. The term “arc” denotes the angle from one end of the curved section to the other about the radical point of the curved section. Alternatively, the sinusoidal or S-shaped portion may be comprised of a pair of joined curved sections wherein each curved section has an arc of greater than 180°—this is illustrated in FIG. 9 of the present application. Further, the pair of joined curved sections can be of the same size (this is illustrated in FIGS. 8 and 9 of the present application) or of differing size (this is illustrated in FIG. 10 of the present application), the latter being the most preferred embodiment.

Preferably, the series of longitudinal struts containing the flexure means comprises all substantially longitudinal struts comprised in the plurality of intersecting members making up the porous surface of the stent.

Preferably, for this aspect of the present invention, the intersecting members are arranged to define a first repeating pattern comprised of a polygon having a pair of side walls substantially parallel to the longitudinal axis (i.e. a pair of the above-mentioned longitudinal struts comprising flexure means), a concave-shaped first wall having a first apex and a convex-shaped second wall having a second apex connecting the side walls. As used throughout this specification, the terms “concave-shaped” and “convex-shaped” are intended to have a broad meaning and a shape having apex.



5

Thus, the first wall has a first apex and the second wall has a second apex. Thus, the first apex (i.e. of the concave-shaped first wall) is directed into the polygon whereas the second apex (i.e. of the convex-shaped second wall) is directed away from the polygon

In another of its aspects, the present invention provides an expandable stent comprising a proximal end and a distal end in communication with one another, a tubular wall disposed between the proximal end and the distal end, the tubular wall having a longitudinal axis and a porous surface defined by a plurality intersecting members arranged to define a first repeating pattern comprised of a polygon having a pair of side walls substantially parallel to the longitudinal axis, a concave-shaped first wall having a first apex and a convex-shaped second wall having a second apex, the first wall and the second wall connecting the side walls, at least one of the first apex and the second apex being substantially flat, the stent being expandable from a first, contracted position to a second, expanded position upon the application of a radially outward force on the stent.

In this aspect of the invention, it has been discovered that the use of such a first repeating pattern (including at least one of the first apex and second apex being substantially flat), with or without the flexure means present in the side walls of the polygon in the first repeating pattern, results in an improved stent. The advantages associated with the use of such a first repeating pattern include the following:

1. the force required to expand the stent is substantially reduced;
2. the stent is subjected to less traumatic stress during expansion;
3. plastic deformation of the stent during expansion is facilitated;
4. construction of the stent is facilitated; and
5. upon expansion of the stent, warpage of the first apex and the second apex is obviated or mitigated.

The provision of at least one of the first apex and the second apex being substantially flat usually results in the apex of the concave-shaped first wall and/or the convex-shaped second wall having a pair of shoulders. Preferably, these shoulders are rounded. The provision of such round shoulders results in the following additional advantages:

6. mitigation of potential trauma to the target body passageway from: (i) endoluminal contents within the passageway, and (ii) the contours of the passageway;
7. the resulting expanded stent is more stream-lined and flow-directed which mitigates potential trauma to the target body passageway;
8. further reduction in the force required to expand the stent;
9. an improved stent expansion ratio is achieved (i.e. ratio of expanded stent diameter at maximum expansion to unexpanded stent diameter);
10. upon expansion of the stent, the concave-shaped first wall and the convex-shaped second wall are in a substantially orthogonal relationship to the longitudinal axis thereby improving the rigidity of the stent (this is very important to mitigate the occurrence of stent recoil); and
11. the pattern of the expanded stent improves the rheology of fluid flow in the body passageway.

When the stent of the present invention includes the above-mentioned first repeating pattern, it is preferred to provide a connecting strut between the first apex and the second apex. Generally, the connecting strut will be sub-

6

stantially longitudinal (i.e. it will be parallel to the longitudinal axis of the stent). This feature mitigates lifting of the shoulders referred to above as the stent is flexed, for example, when passing the stent through a curved body passageway. The result of this is that potential trauma to the body passageway is mitigated since scraping of the body passageway by the shoulders is mitigated.

In a preferred embodiment, the connecting strut is curved with respect to the longitudinal axis (this is described and illustrated hereinbelow). Preferably, the strut is sufficiently curved to have a length of up to about 35%, more preferably up to about 15%, even more preferably in the range of from about 2% to about 8%, most preferably in the range of from about 3% to about 7%, greater than the distance between the first apex and the second apex. This feature improves the lateral flexibility of the stent thereby facilitating implantation thereof. In some cases, the curvature may be designed to comprise the flexure means discussed above. In other words, the shape of the curvature may be designed substantially complementary extension and compression of the connecting strut upon flexure of the stent.

Yet another preferred feature of the stent of the present invention is the provision of one or both of the side walls of the polygon of the repeating pattern being curved. Preferably, both side walls are curved. More preferably the curvature serves as flexure means as described above. Ideally, the curved side wall has length of up to about 35%, more preferably up to about 15%, even more preferably in the range of from about 2% to about 8%, most preferably in the range of from about 3% to about 7%, greater than the distance between the termini of the concave-shaped first wall and the concave-shaped second wall. This feature improves the lateral flexibility of the strut thereby facilitating implantation thereof.

Preferably, both the strut and the side walls are curved. More preferably, each of the curved members are of substantially the same length.

Yet another preferred feature of the stent of the present invention is, in addition to the strut and side walls of the polygon being curved, the provision of all longitudinal walls of the polygon of the repeating pattern being curved. Thus, in this embodiment of the invention, the concave-shaped first wall comprises a pair of curved first apex walls connecting the first apex and the side walls of the polygon, and the convex-shaped second wall comprises a pair of curved second apex walls connecting the second apex and the side walls of the polygon. Again, in some cases, the curvature may be designed to comprise the flexure means discussed above. Ideally, the curved first apex walls and the curved second apex walls each have a length of up to about 35%, more preferably up to about 15%, even more preferably in the range of from about 2% to about 8%, most preferably in the range of from about 3% to about 7%, greater than the straight (i.e. non-curved) distance between the first apex and the side walls, and the second apex and the side walls, respectively. In this embodiment, it is further preferred to have substantially all adjacent curved walls in an annular section of the repeating pattern (i.e. of the struts, first apex wall, second apex wall and side walls) are substantially equidistant from one another. This preferred feature of the stent of the present invention even further enhances the lateral flexibility of the stent thereby further facilitating implantation thereof.

Yet another preferred feature of the stent of the present invention is provision of a porous surface comprising multiple designs. Specifically, in certain cases, it may be desirable to design the stent to varying degrees of relative



flexibility and rigidity along the length thereof. Thus, the relatively flexible portion(s) of such a stent would facilitate delivery of the stent to a target body passageway through a relatively tortuous route, while the relatively rigid portion(s) of the stent serves facilitate maintaining the patency of the body passageway. As will be discussed in more detail hereinbelow, this may be achieved by varying the repeating pattern design along the longitudinal length of the stent.

An aspect of the present invention relates to the provision of an expandable bifurcated stent. As used throughout this specification, the term "bifurcated stent" is intended to have a broad meaning and encompasses any stent having a primary passageway to which is connected at least two secondary passageways. Thus, trifurcated stents are encompassed herein. Further, one of the secondary passageways can be a continuation of the primary passageway with the result that the other secondary passageway is essentially a side branch to the primary passageway.

The stent of the present invention (bifurcated or mono-tubular) can further comprise coating material thereon. The coating material can be disposed continuously or discontinuously on the surface of the stent. Further, the coating may be disposed on the interior and/or the exterior surface(s) of the stent. The coating material can be one or more of a biologically inert material (e.g. to reduce the thrombogenicity of the stent), a medicinal composition which leaches into the wall of the body passageway after implantation (e.g. to provide anticoagulant action, to deliver a pharmaceutical to the body passageway and the like) and the like.

The stent is preferably provided with a biocompatible coating, in order of minimize adverse interaction with the walls of the body vessel and/or with the liquid, usually blood, flowing through the vessel. The coating is preferably a polymeric material, which is generally provided by applying to the stent a solution or dispersion of preformed polymer in a solvent and removing the solvent. Non-polymeric coating material may alternatively be used. Suitable coating materials, for instance polymers, may be polytetrafluoroethylene or silicone rubbers, or polyurethanes which are known to be biocompatible. Preferably however the polymer has zwitterionic pendant groups, generally ammonium phosphate ester groups, for instance phosphoryl choline groups or analogues thereof. Examples of suitable polymers are described in International application number WO-A-93/16479 and WO-A-93/15775. Polymers described in those specifications are hemo-compatible as well as generally biocompatible and, in addition, are lubricious. It is important to ensure that the surfaces of the stent are completely coated in order to minimize unfavourable interactions, for instance with blood, which might lead to thrombosis.

This good coating can be achieved by suitable selection of coating conditions, such as coating solution viscosity, coating technique and/or solvent removal step.

In another embodiment of the invention, the stent may be joined to a polymer material. Specifically, a polymer material may be extruded onto the stent in such a manner that it envelops at least a portion of the stent. This technique may be used to join two or more stents with a flexible polymeric tube. This technique may also be used to join a stent to another prosthetic device such as a tube, a graft and the like. Thus, in this embodiment of the invention, the stent is incorporated into an endoluminal prosthesis.

In yet another embodiment of the invention, the stent may be secured (e.g by suturing) to an existing endoluminal prosthesis such as Gortex™ material or to biological material such as basilic vein. In this regard, securing of the stent

to the existing endoluminal prosthesis or biological material may be facilitated by designing the stent such that an end of the stent comprises an annular row of the above-mentioned polygons is having a convex-shaped wall with a flat apex.

#### BRIEF DESCRIPTION OF THE DRAWINGS

Embodiments of the present invention will be described with reference to the accompanying drawings wherein like numerals designate like parts and in which:

FIG. 1 illustrates an exploded perspective view of a mono-tubular stent prior to expansion;

FIG. 1A illustrates an exploded view of a portion of the stent illustrated in FIG. 1;

FIGS. 2–10 each illustrate a two dimensional representation of various embodiments (not to relative scale) of a repeating pattern useful in the stent of the present invention;

FIG. 11 illustrates an ostial stenosis to which a preferred embodiment of the invention may be applied; and

FIGS. 12a–12i illustrate various embodiments of flexure means (in two dimensions) which may be disposed in the longitudinal struts of preferred embodiments of the present stent.

#### BEST MODE FOR CARRYING OUT THE INVENTION

With reference to FIG. 1, there is illustrated a stent 10. Stent 10 comprises a proximal end 15 and a distal end 20. Stent further comprises a tubular wall 25 disposed between proximal end 15 and distal end 20. As illustrated, tubular wall 25 is porous. The porosity of tubular wall 25 is defined by a plurality of intersecting members 30. Intersecting members 30 define a first repeating pattern designated A in FIG. 1.

As illustrated and with further reference to FIG. 1A, repeating pattern A is a polygon comprising a pair of side walls 35,40. Side walls 35,40 are substantially parallel to a longitudinal axis 45 of stent 10 and thus side walls 35,40 may be considered to be longitudinal struts (indeed with reference to each of the drawings, side walls may also be considered to be longitudinal struts). Side walls 35,40 are connected by a concave-shaped wall 50 and a convex-shaped wall 60.

As illustrated, concave-shaped wall 50 is made up of a trio of segments 52,54,56. In the illustrated embodiment, segment 54 is the apex of concave-shaped wall 54. As is evident, segment 54 is a flat apex and results in the provision of a pair of substantially square shoulder 57,58. Convex-shaped wall 60 is made up of a trio of segments 62,64,66. In the illustrated embodiment, segment 64 is the apex of convex-shaped wall 60.

It will be appreciated by those of skill in the art that the provision of first repeating pattern A, as illustrated, necessarily defines and provides for a second repeating pattern B. It will also be appreciated by those of skill in the art that second repeating pattern B is a mirror image of first repeating pattern A taken along an axis (not shown) substantially normal to longitudinal axis 45. Thus, in the illustrated embodiments, adjacent rows of repeating pattern A and repeating pattern B may be considered to be interlocking polygons or "arrowheads"

It will be further appreciated by those of skill in the art that the shape of concave-shaped wall 50 and/or convex-shaped wall 60 can be modified without departing from the function and performance of the stent provided that at least one of concave-shaped wall 50 and convex-shaped wall 60



retain a substantially flat apex. For example, the trio of segments can be replaced by a suitably curved or arcuate wall. Alternatively, more than three segments can be used to define concave-shaped wall **50** and/or convex-shaped wall **60**. Other modifications will be apparent to those of skill in the art.

It will be further appreciated by those of skill in the art that various walls of first repeating pattern A and second repeating pattern B may be omitted (and even desired) at selected points along the body of the stent without departing from the spirit and scope of the invention. For example, it is possible to omit one or both of side walls **35** and **40** at selected points along the body of the stent with a view to improving the longitudinal flexibility of the stent. Further, it is possible to omit one or more of segments **62,64,66** at selected points along the body of the stent with a view to improving the lateral flexibility of the stent.

Still further, the stent depicted in FIG. 1 can be modified to omit, on a selected basis, first repeating pattern A and/or second repeating B with a view to improve flexibility of the stent and to allow access to other structures (e.g. side branches/arteries) outside the bounds of the stent.

With reference to FIGS. 2–10, there are illustrated a number of preferred embodiments of repeating pattern A. For the sake of clarity, numerals in FIGS. 2–8 have the same final two digits as the corresponding numerals in FIG. 1. Thus, for example, the concave-shaped wall is depicted as element **50** in FIG. 1, element **150** in FIG. 2, element **250** in FIG. 3, etc.

Thus, as illustrated in FIG. 2, repeating pattern A is comprised of a concave-shaped wall **150** and a convex-shaped wall **160**, the former having a flat apex. Further, as illustrated, concave-shaped wall **150** and convex-shaped wall **160** are not equidistant along an axis orthogonal to the longitudinal axis of the stent (not shown). Thus, in this embodiment, the flat apex in concave-shaped wall **150** has been modified such that it comprises a pair of substantially rounded shoulders **157,158**.

With reference to FIG. 3, repeating pattern A is similar to the one illustrated in FIG. 1. In FIG. 3, the flat apex of concave-shaped wall **250** has been modified to provide a pair of rounded shoulders **257,258**. Further, a strut **270** has been added to connect segment **254** of concave-shaped wall **250** and segment **264** of convex-shaped wall **260**. As illustrated, strut **270** is thinner in dimension than any of the segments making up concave-shaped wall **250** and convex-shaped wall **260**. Thus, strut **270** may be considered as a relatively thin retention wire which reconciles the need for retaining flexibility in the strut with mitigating lifting of rounded shoulders **257,258** when the stent is delivered to the target body passageway through a relatively tortuous route.

With reference to FIG. 4, repeating pattern A is similar to the one illustrated in FIG. 1. In FIG. 4, the flat apex of concave-shaped wall **350** has been modified to provide a pair of rounded shoulders **357,358**. Further, a curved strut **370** has been added to connect segment **354** of concave-shaped wall **350** and segment **364** of convex-shaped wall **360**.

With reference to FIG. 5, repeating pattern A is similar to the one illustrated in FIG. 1. In FIG. 5, the flat apex of concave-shaped wall **450** has been modified to provide a pair of rounded shoulders **457,458**. Further, a curved strut **470** has been added to connect segment **454** of concave-shaped wall **450** and segment **464** of convex-shaped wall **460**. Further, side walls **435,440** are also curved. As discussed above, since side walls **435,440** are bowed in oppo-

site directions in adjacent rows of repeating pattern A and B, substantially diametric side walls in adjacent rows will function as the flexure means described above.

With reference to FIG. 6, repeating pattern A is similar to the one illustrated in FIG. 1. In FIG. 6, concave-shaped wall **550** has been modified to have a flat apex **554** having a pair of rounded shoulders **557,558** and convex-shaped wall **560** has been modified also to have a flat apex **564** having a pair of rounded shoulders **567,568**. Further, a curved strut **570** has been added to connect flat apex **554** of concave-shaped wall **550** and flat apex **564** of convex-shape wall **560**. Further, side walls **535,540** are also curved.

With reference to FIG. 7, repeating pattern A is similar to the one illustrated in FIG. 1. In FIG. 7, concave-shaped wall **650** has been modified to have a flat apex **654** having a pair of rounded shoulders **657,658** and convex-shape wall **660** has been modified also to have a flat apex **664** having a pair of rounded shoulders **667,668**. Further, a curved strut **670** has been added to connect flat apex **654** of concave-shaped wall **650** and flat apex **664** of convex-shape wall **660**. Further, side walls **635,640** are also curved. Still further, walls **661,662** which connect flat apex **664** to side walls **635,640**, respectively, and walls **651,652** which connect flat apex **654** to side walls **635,640**, respectively, are each curved. It is believed that this design even further enhances the lateral flexibility of the stent.

With reference to FIG. 8, repeating pattern A is similar to the one illustrated in FIG. 1. In FIG. 7, concave-shaped wall **750** has been modified to have a flat apex **754** having a pair of rounded shoulders **757,758** and convex-shape wall **760** has been modified also to have a flat apex **764** having a pair of rounded shoulders **767,768**. Further, a strut **770** has been added to connect flat apex **754** of concave-shaped wall **750** and flat apex **764** of convex-shaped wall **760**. Further, side walls **735,740** have been modified to include a sinusoidal (or S-shaped) portion **736,741**, respectively, adjacent convex-shaped wall **760**. Further, strut **770** has been modified to include a sinusoidal (or S-shaped) portion **771** adjacent flat apex of concave-shaped wall **750**. This design even further enhances the lateral flexibility of the stent.

With reference to FIG. 9, repeating pattern A is similar to the one illustrated in FIG. 1. In FIG. 9, concave-shaped wall **850** has been modified to have a flat apex **854** having a pair of rounded shoulders **857,858**. Further, side walls **835,840** have been modified to include a pair of sinusoidal (or S-shaped) portions **836,841**, respectively, adjacent convex-shaped wall **860**. This design further enhances the lateral flexibility of the stent illustrated in FIG. 2. It should be noted that each sinusoidal (or S-shaped) portion **836,841** in FIG. 9 comprises a pair of adjoined curved sections wherein each curved section has an arc of greater than 180°—another way to conceptualize this is a pair of link omega-shaped sections (cf. with the curved sections of sinusoidal (or S-shaped) portions **736,741,771** in FIG. 8).

With reference to FIG. 10, repeating pattern A is similar to the one illustrated in FIG. 1. In FIG. 10, concave-shaped wall **950** has been modified to have a flat apex **954** having a pair of rounded shoulders **957,958**. Further, a strut **970** has been added to connect flat-apex **954** of concave-shaped wall **950** and segment **964** of convex-shaped wall **960**. Further, side walls **935,940** have been modified to include a pair of sinusoidal (or S-shaped) portions **936,941**, respectively, adjacent convex-shaped wall **960**. Further, strut **970** has been modified to include sinusoidal (or S-shaped) portion **971** adjacent flat apex of concave-shaped wall **950**. It should be noted that each sinusoidal (or S-shaped) portion **936,941**,



## 11

971 in FIG. 10 comprises a pair of adjoined curved sections wherein each curved section has an arc of greater than 180°. Further, the curved sections in sinusoidal (or S-shaped) portions 936,941 are of the same size, whereas the curved sections in sinusoidal (or S-shaped) portion 971 are of different size. A distinct advantage of the interspersion of sinusoidal (or S-shaped) portions 936,941 and sinusoidal (or S-shaped) portion 971 is that substantially uniform radial expansion of all segments in this stent will occur without specific regard to the expansion forces generated by the balloon or other means used to deploy the stent. Further, this design minimizes the force (e.g. pressure from a balloon) required to expand the stent. Still further, this design enhances the lateral flexibility of the stent.

As will be apparent to those of skill in the art, sinusoidal (or S-shaped) portion 971 is offset with respect to sinusoidal (or S-shaped) portions 936,941 in a panel horizontal to the longitudinal axis of repeating pattern A. The offset nature of these sinusoidal (or S-shaped) portions serves to increase the bending points in the stent allowing the stent to bend while avoiding buckling thereof. Thus, the staged distribution of the sinusoidal (or S-shaped) portions over a large portion of the surface area of the stent serves to improve the flexibility of the stent.

The advantages of the various alternate embodiments illustrated in FIGS. 2–10 are discussed hereinabove.

As discussed above, the use of flexure means, such as the sinusoidal (or S-shaped) portions in the design of the stents illustrated in FIGS. 8–10, in the longitudinal struts in the stent design provides the added benefit of improved flexibility of the stent in the unexpanded state. Specifically, during flexure of the stent, provision of such a feature allows the inner stent surface adjacent the bend to compress while concurrently allowing the outer stent surface adjacent the bend to extend, all while maintain substantially intact the integral strength of stent and avoiding buckling of the stent.

Accordingly the provision of such flexure means in the longitudinal struts of an otherwise general stent design is another feature of invention. With reference to FIGS. 12a–12i there are illustrated various alternatives of bowed lateral sections which can be used in place of sinusoidal (or S-shaped) portions 736,741,771 in FIG. 8, sinusoidal (or S-shaped) portions 836,841 in FIG. 9 and sinusoidal (or S-shaped) portions 936,941,971 in FIG. 10. Thus, the flexure means illustrated in FIG. 12a may be considered to be an asymmetric zig-zag whereas that illustrated in FIG. 12b may be considered to be a symmetric zig-zag and that illustrated in FIG. 12c may be considered to be an in line symmetric double peak. The flexure means illustrated in FIG. 12d may be considered to be a single omega, whereas that illustrated in FIG. 12e may be considered to be an inline (and unlinked) double omega and that illustrated in FIG. 12f may be considered to be an opposed (and unlinked) double omega. The flexure means illustrated in FIG. 12g may be considered to be an opposed omega (facilitates extension)/U-joint (facilitates compression). Still further the flexure means illustrated in FIG. 12h may be considered to be a rail flex whereas that illustrated in FIG. 12i may be considered to be an opposed rail flex. Other specific designs which are with the spirit and scope of the present invention will be apparent to those of skill in the art

Those of skill in the art will recognize that it is possible to combine various of the alternate embodiments illustrated in FIGS. 2–10 and 12 to derive further designs which are still within the spirit and scope of the present invention. Specifically, a preferred embodiment of the present inven-

## 12

tion involves combining various of the repeating patterns illustrated in FIGS. 2–10 to achieve a stent with relatively flexible and rigid regions, for example, as follows:

F-R

F-R-F

R-F-R

wherein F is a relatively flexible region and R is a relatively rigid region. With reference to the embodiments illustrated in FIGS. 1–10, the trackability of the stent through a tortuous pathway is enhanced from the design illustrated in FIG. 1 progressively through to the design illustrated in FIG. 10. For example, an embodiment of the invention is a stent comprising a first section incorporating the design of FIG. 10 and a second section incorporating the design of FIG. 9. It is believed that such a multi-sectional design provides a very desirable combination of lateral flexibility (primarily from the design of FIG. 9) with post-expansion radial rigidity (primarily from the design of FIG. 10).

Another technique by which the relative flexibility/rigidity may be varied along the length of the stent involves varying the thickness of the segments making up the polygon discussed hereinabove. Specifically, the thickness of the segments may be varied in the range of from about 0.0015 to about 0.0045 inches, preferably from about 0.0020 to about 0.0040 inches. The lower the thickness in this range, the more flexible the resulting stent design. Conversely, the higher the thickness in this range, the less flexible the resulting stent design. Thus, by judicious selection of segment thickness, the relative flexibility/rigidity of the stent may be varied along its length.

The provision of a stent with a variable relative flexibility/rigidity along its length is believed to be novel, especially a stent comprising a single relatively flexible portion and a single relatively rigid portion (i.e. the F-R embodiment discussed above). Such a stent would find immediate use in a number of applications. For, example, such a stent would very desirable for implantation in an ostial stenosis (these typically occur in coronary arteries, vein grafts and renal arteries). In this regard, an ostial stenosis is illustrated in FIG. 11 thereof. Thus, there is illustrated a right coronary cusp 105, a right coronary artery 110 and an ostial segment 115 of right coronary artery 110. As further illustrated a stenosis 120 presents a narrowing of ostial segment 115. Ideally, a stent capable of implantation into such an ostial stenosis must be of sufficient rigidity after expansion to resist the elastic recoil of the ostial blockage (Region Y in FIG. 11). However, a stent of such sufficient rigidity will be deficient since it will either: (i) be retarded in its advance along the artery due to the sharp bend in the right coronary artery (Region X in FIG. 11); or (ii) traverse the sharp bend in the right coronary artery but subsequently straighten Region X of right coronary artery 110 thereby increasing the likelihood of tearing the artery. Conversely, a stent of sufficiently flexibility to traverse the sharp bend in the right coronary artery (Region X in FIG. 11) is susceptible to recoil in the ostial right coronary artery (Region Y in FIG. 11). Accordingly, to the knowledge of the Applicant, there is no known effective manner by which a stent may be used to treat an ostial stenosis of the type illustrated in FIG. 11. It is believed that a stent having variable relative rigidity/flexibility along its length as discussed above is a novel means by which an ostial stenosis may be treated. FIG. 11 also serves to illustrate the substantially complementary extension and compression of longitudinal members in Region X of the right coronary artery



The manner by which the present stent is manufactured is not particularly restricted. Preferably, the stent is produced by laser cutting techniques applied to a tubular starting material. Thus, the starting material could be a thin tube of a metal or alloy (non-limiting examples include stainless steel, titanium, tantalum, nitinol, Elgiloy, NP35N and mixtures thereof) which would then have sections thereof cut out to leave repeating pattern A discussed above. Thus, the preferred design of the present stent is one of a tubular wall which is distinct from prior art wire mesh designs wherein wire is conformed to the desired shape and welded in place. The preferred tubular wall design of the present stent facilitates production and improves quality control by avoiding the use of welds and, instead, utilizing specific cutting techniques.

Preferably, the stent is coated with a solution of 1:2 (mole) copolymer of (methacryloyloxy ethyl)-2-(trimethylammonium ethyl) phosphate inner salt with lauryl methacrylate in ethanol (as described in Example 2 of International patent application WO-A-93/01221) as follows. The non-expanded stent may be placed in a tube having a slightly larger diameter than the stent. The tube may then be filled with coating solution and the solution allowed to drain steadily from the tube to form a completely coated stent. Immediately thereafter a stream of warm air or nitrogen may be directed through the tube at a linear velocity of 0.1.5 m/s at room temperature to 50° C. for a period of 30 seconds to 5 minutes to dry the coating by evaporation of the ethanol solvent.

As an alternative or in addition (on top or underneath) to this coating, a cross-linkable coating may be used consisting of a polymer of 23 mole % (methacryloyloxy ethyl)-2-(trimethylammonium ethyl) phosphate inner salt, 47 mole % lauryl methacrylate, 5 mole %  $\gamma$ trimethoxysilylpropyl methacrylate and 25 mole % of  $\gamma$ hydroxypropyl methacrylate. This may be applied to the stent by the above described technique from a 5 mg/ml ethanoic solution. The solution may be dried as described above and then cured by heating at 70 to 75° C. for a period of at least about 1 hour, for instance overnight. This curing generally results in substantially complete reaction of the methoxy silyl groups, either with other methoxysilyl groups or with hydroxy groups derived from the hydroxypropyl methacrylate monomer, driving off methanol. In one preferred embodiment the crosslinkable coating is applied to the cleared stent, cured and then a further coating of the lauryl methacrylate copolymer described above is applied.

The coated stent may be sterilised by ethylene oxide, gamma radiation or electron beam and subsequently mounted onto a balloon catheter for delivery.

Stent **10** can be implanted using a conventional system wherein a guidewire, catheter and balloon can be used to position and expand the stent. Implantation of mono-tubular stents such as stent **10** is conventional and within the purview of a person skilled in the art. See, for example, any one of U.S. Pat. Nos. 4,733,665, 4,739,762, 5,035,706, 5,037,392, 5,102,417, 5,147,385, 5,282,824, 5,316,023 and any of the references cited therein or any of the references cited hereinabove. When the present stent is constructed as a bifurcated stent, it may be implanted using the procedure outlined in the '997 patent application incorporated herein by reference. Such a bifurcated stent may be manufactured, inter alia, by any of the methods disclosed in the Canadian patent application number 2,175,720 filed in Applicant's name on May 3, 1996, the contents of which are hereby incorporated by reference.

It will be apparent to those of skill in the art that implantation of stent **10** can be accomplished by various

other means. For example, it is contemplated that the stent can be made of a suitable material which will expand when a certain temperature is reached. In this embodiment, the material may be a metal alloy (e.g. nitinol) capable of self-expansion at a temperature of at least about 30° C., preferably in the range of from about 30° to about 40° C. In this embodiment, the stent could be implanted using a conventional catheter and the radially outward force exerted on the stent would be generated within the stent itself. Further, stent **10** can be designed to expand upon the application of mechanical forces other than those applied by a balloon/catheter. For example, it is possible to implant stent **10** using a catheter equipped with a resisting sleeve or retaining membrane which may then be removed with the catheter once the stent is in position thereby allowing the stent to expand. Thus, in this example, the stent would be resiliently compressed and would self-expanded once the compressive force (i.e. provided by the sleeve or membrane) is removed.

As will be appreciated by those of skill in the art, repeating pattern A has been described hereinabove and illustrated in FIG. 1 in respect of a monotubular stent. Repeating pattern A and all of the features relating thereto illustrated in and described with reference to FIGS. 1-10 (including modification to include the flexure means illustrated in FIGS. 12a-12i) is equally applicable to a bifurcated stent such as the one described and illustrated in the '997 application discussed hereinabove, the contents of which are hereby incorporated by reference.

While this invention has been described with reference to illustrative embodiments, this description is not intended to be construed in a limiting sense. Various modifications of the illustrative embodiments, as well as other embodiments of the invention, will be apparent to persons skilled in the art upon reference to this description. It is therefore contemplated that the appended claims will cover any such modifications or embodiments.

What is claimed is:

1. An expandable stent comprising:

a proximal end and a distal end in communication with one another,

a tubular wall disposed between the proximal end and the distal end, the tubular wall having a longitudinal axis and a porous surface defined by a plurality of intersecting members comprising (i) a series of longitudinal struts disposed substantially parallel to the longitudinal axis of the stent, and (ii) a series of circumferential struts undulating in a circumferential direction,

each of the longitudinal struts comprising arcuate flexure means for substantially complementary extension and compression of a diametrically opposed pair of the longitudinal struts upon flexure of the stent, the stent being expandable from a first, contracted position to a second, expanded position upon the application of a radially outward force on the stent, said flexure means being thinner than at least one adjacent circumferential strut when measured on the other surface of the tubular wall, said flexure means comprising a sinusoidal cycle disposed between a start point and an end point which are in substantial alignment with the longitudinal axis, the distance between the start point and the end point being less than a minimum distance between an adjacent pair of circumferential struts.

2. The stent defined in claim 1, wherein said circumferential struts are arranged to define alternating peaks and valleys.

3. The stent defined in claim 2, wherein the peaks in adjacent circumferential struts are in substantial alignment along the longitudinal axis.



## 15

4. The stent defined in claim 1, wherein the flexure means comprises at least a first lateral section and second lateral section disposed in each longitudinal strut in the stent.

5. The stent defined in claim 4, wherein the first lateral section and the second lateral section are symmetric.

6. The stent defined in claim 4, wherein the first lateral section and the second lateral section are asymmetric.

7. The stent defined in claim 6, wherein the first lateral section and the second lateral section have substantially the same shape and differing size.

8. The stent defined in claim 6, wherein the first lateral section and the second lateral section have differing size.

9. The stent defined in claim 4, wherein the first lateral section and the second lateral section have substantially the same shape and differing size.

10. An expandable stent comprising:

a proximal end and a distal end in communication with one another,

a tubular wall disposed between the proximal end and the distal end, the tubular wall having a longitudinal axis and a porous surface defined by a plurality of intersecting members comprising (i) a series of longitudinal struts disposed substantially parallel to the longitudinal axis of the stent, and (ii) a series of circumferential struts undulating in a circumferential direction,

each of the longitudinal struts comprising a curved flexure member for substantially complementary extension and compression of a diametrically opposed pair of the longitudinal struts upon flexure of the stent, the stent being expandable from a first, contracted position to a second, expanded position upon the application of a radially outward force on the stent, said flexure member being thinner than adjacent circumferential struts when measured on the outer surface of the tubular wall, said flexure member comprising a sinusoidal cycle disposed between a start point and an end point which are in substantial alignment with the longitudinal axis, the distance between the start point and the end point being less than a minimum distance between an adjacent pair of circumferential struts, wherein the plurality of intersecting members are arranged to define a first repeating pattern comprised of a polygon having a pair of side walls substantially parallel to the longitudinal axis and the flexure member is disposed in each of the side walls.

11. The stent defined in claim 10, wherein the flexure member comprises a pair of joined curved sections, wherein each curved section has an arc of substantially 180°.

12. The stent defined in claim 11, wherein the curved sections are of substantially the same size.

13. The stent defined in claim 11, wherein the curved sections are of different sizes.

14. The stent defined in claim 1, wherein the series of longitudinal struts comprising the flexure means includes all longitudinal struts in the porous surface.

15. The stent defined in claim 1, wherein the stent is constructed of stainless steel.

16. The stent defined in claim 1, wherein the stent is constructed of a self-expanding material.

17. The stent defined in claim 16, wherein the self-expanding material comprises nitinol.

18. The stent defined in claim 16, wherein the self-expanding material expands at a temperature of greater than about 30° C.

19. The stent defined in claim 16, wherein the self-expanding material expands at a temperature of in the range of from about 30° to about 40° C.

## 16

20. The stent defined in claim 1, wherein the stent has a medicinal coating thereon.

21. A balloon catheter comprising an expandable portion and the stent defined in claim 1 disposed in the expandable portion.

22. The stent defined in claim 10, wherein the stent has a medicinal coating thereon.

23. A balloon catheter comprising an expandable portion and the stent defined in claim 10 disposed on the expandable portion.

24. An unexpanded stent comprising:

a tubular wall having a porous surface defined by a plurality of intersecting members comprising (i) a series of longitudinally extending struts disposed substantially parallel to the longitudinal axis of the stent, and (ii) a series of nonlinear circumferential struts undulating in a circumferential direction,

a flexure member disposed in at least two of the longitudinally extending struts, each said flexure member comprising a curved undulating portion having a start point and an end point in substantial alignment with the longitudinal axis, said curved undulating portion being thinner than at least one adjacent circumferential strut when measured on the outer surface of the tubular wall, said flexure member comprising a sinusoidal cycle disposed between the start point and the end point, the distance between the start point and the end point being less than a minimum distance between an adjacent pair of circumferential struts.

25. The stent defined in claim 24, wherein the circumferential struts are undulating.

26. The stent defined in claim 24, wherein the tubular wall has a medicinal coating thereon.

27. A balloon catheter comprising an expandable portion and the stent defined in claim 24 disposed on the expandable portion.

28. The stent defined in claim 24, wherein the flexure member is isolated from two circumferential struts.

29. The stent defined in claim 24, wherein the flexure member comprises at least a first lateral section and a second lateral section disposed in each longitudinally extending strut in the stent.

30. The stent defined in claim 29, wherein the first lateral section and the second lateral section are symmetric.

31. The stent defined in claim 29, wherein the first lateral section and the second lateral section are asymmetric.

32. The stent defined in claim 29, wherein the first lateral section and the second lateral section have substantially the same shape and differing size.

33. The stent defined in claim 29, wherein the first lateral section and the second lateral section have differing size.

34. The stent defined in claim 29, wherein the first lateral section and the second lateral section have substantially the same shape and differing size.

35. The stent defined in claim 24, wherein the stent is constructed of stainless steel.

36. The stent defined in claim 24, wherein the stent is constructed of a self-expanding material.

37. The stent defined in claim 36, wherein the self-expanding material comprises nitinol.

38. The stent defined in claim 36, wherein the self-expanding material expands at a temperature of greater than about 30° C.

39. The stent defined in claim 36, wherein the self-expanding material expands at a temperature of in the range of from about 30° to about 40° C.

40. The stent defined in claim 24, wherein the series of nonlinear circumferential struts comprises a plurality of



circumferential rows of struts, each row of struts arranged to define alternating peaks and valleys.

41. The stent defined in claim 40, wherein peaks in adjacent circumferential rows of struts are in substantial alignment along the longitudinal axis.

42. The stent defined in claim 40, wherein valleys in adjacent circumferential rows of struts are in substantial alignment along the longitudinal axis.

43. The stent defined in claim 40, wherein peaks in a circumferential row of struts and valleys in an adjacent circumferential row are in substantial alignment along the longitudinal axis.

44. The stent defined in claim 40, wherein each peak in adjacent pairs of circumferential rows of struts is connected to a longitudinally extending strut.

45. The stent defined in claim 40, wherein each valley in adjacent pairs of circumferential rows of struts is connected to a longitudinally extending strut.

46. The stent defined in claim 40, wherein a longitudinally extending strut interconnects a valley and a peak in adjacent pairs of circumferential rows of struts.

47. The stent defined in claim 40, wherein the longitudinally extending struts interconnect adjacent pairs of circumferential rows of struts at a first connection point on a circumferential row of struts and a second connection point or an adjacent circumferential row of struts.

48. The stent defined in claim 47, wherein a line drawn through the first connection point and the second connection point is substantially parallel to the longitudinal axis.

49. The stent defined in claim 47, wherein a line drawn through the first connection point and the second connection point is substantially non-parallel to the longitudinal axis.

50. An unexpanded stent comprising:

a tubular wall having a porous surface defined by a plurality of intersecting members comprising (i) a series of longitudinally extending struts disposed substantially parallel to the longitudinal axis of the stent, and (ii) a plurality of circumferential rows of struts undulating in a circumferential direction, each row of struts arranged to define alternating peaks and valleys,

a flexure member disposed in at least two of the longitudinally extending struts, each said flexure member comprising a curved undulating portion having a start point and an end point in substantial alignment with the longitudinal axis, said curved undulating portion being thinner than at least one adjacent circumferential strut when measured on the outer surface of the tubular wall, said flexure member comprising a sinusoidal cycle disposed between the start point and the end point, the distance between the start point and the end point being less than a minimum distance between an adjacent pair of circumferential struts;

wherein the longitudinally extending struts interconnect adjacent pairs of circumferential rows of struts at a first connection point on a circumferential row of struts and a second connection point on an adjacent circumferential row of struts such that a line drawn through the first connection point and the second connection point is substantially non-parallel to the longitudinal axis.

51. The stent defined in claim 50, wherein the flexure member comprises at least one S-shaped portion disposed in each longitudinally extending strut in the stent.

52. The stent defined in claim 50, wherein the flexure member comprises a circumferentially extending first curved section and a circumferentially extending second curved section.

53. The stent defined in claim 52, wherein the first section and the second section each comprises a curved apex.

54. The stent defined in claim 53, wherein the curved apex of the first section and the curved apex of the second section are interconnected by a straight section oriented transverse to the longitudinal axis.

55. The stent defined in claim 50, wherein the tubular wall has a medicinal coating thereon.

56. A balloon catheter comprising an expandable portion and the stent defined in claim 55 disposed in the expandable portion.

57. The expandable stent defined in claim 1, wherein the longitudinal struts interconnect adjacent pairs of circumferential struts at a first connection point on a first circumferential strut and a second connection point on a second circumferential strut adjacent to the first circumferential strut such that a line drawn through the first connection point and the second connection point is substantially non-parallel to the longitudinal axis.

58. The expandable stent defined in claim 10, wherein the longitudinal struts interconnect adjacent pairs of circumferential struts at a first connection point on a first circumferential strut and a second connection point on a second circumferential strut adjacent to the first circumferential strut such that a line drawn through the first connection point and the second connection point is substantially non-parallel to the longitudinal axis.

59. The unexpanded stent defined in claim 24, wherein the longitudinally extending struts interconnect adjacent pairs of circumferential struts at a first connection point on a first circumferential strut and a second connection point on a second circumferential strut adjacent to the first circumferential strut such that a line drawn through the first connection point and the second connection point is substantially non-parallel to the longitudinal axis.

60. The expandable stent defined in claim 1, wherein the plurality of intersecting members are arranged to define a repeating pattern comprised of rows of polygons arranged circumferentially around the longitudinal axis, a longitudinally adjacent pair of polygons: (i) sharing a common circumferential strut, and (ii) being identically oriented.

61. The expandable stent defined in claim 10, wherein the repeating pattern is comprised of rows of the polygons arranged circumferentially around the longitudinal axis, a longitudinally adjacent pair of polygons: (i) sharing a common circumferential strut, and (ii) being identically oriented.

62. The unexpanded stent defined in claim 24, wherein the plurality of intersecting members are arranged to define a repeating pattern comprised of rows of polygons arranged circumferentially around the longitudinal axis, a longitudinally adjacent pair of polygons: (i) sharing a common circumferential strut, and (ii) being identically oriented.

63. The unexpanded stent defined in claim 50, wherein the plurality of intersecting members are arranged to define a repeating pattern comprised of rows of polygons arranged circumferentially around the longitudinal axis, a longitudinally adjacent pair of polygons: (i) sharing a common circumferential strut, and (ii) being identically oriented.



UNITED STATES PATENT AND TRADEMARK OFFICE  
**CERTIFICATE OF CORRECTION**

PATENT NO. : 6,881,223 B2  
APPLICATION NO. : 10/190818  
DATED : April 19, 2005  
INVENTOR(S) : Ian M. Penn and Donald R. Ricci

Page 1 of 1

It is certified that error appears in the above-identified patent and that said Letters Patent is hereby corrected as shown below:

On the Cover Page under (30) **Foreign Application Priority Data**, “Mar. 6 1996 (CA) ... 2171047” should read --Mar. 5, 1996 (CA)...2171047--.

Column 14, Line 55 “on the other surface” should read --on the outer surface--.

Column 18, Line 14 “disposed in the expandable portion” should read --disposed on the expandable portion--.

Claim 21, Column 16, line 4, “in the expandable portion” should read --on the expandable portion--.

Claim 47, Column 17, Line 26 “or an adjacent” should read --on an adjacent--.

Signed and Sealed this

Twenty-ninth Day of May, 2007

A handwritten signature in black ink on a light gray dotted background. The signature reads "Jon W. Dudas" in a cursive style.

JON W. DUDAS

*Director of the United States Patent and Trademark Office*

UNITED STATES PATENT AND TRADEMARK OFFICE  
**CERTIFICATE OF CORRECTION**

PATENT NO. : 6,881,223 B2  
APPLICATION NO. : 10/190818  
DATED : April 19, 2005  
INVENTOR(S) : Ian M. Penn et al.

Page 1 of 1

It is certified that error appears in the above-identified patent and that said Letters Patent is hereby corrected as shown below:

On the Cover Page under (30) **Foreign Application Priority Data**, “Mar. 6 1996 (CA) ... 2171047” should read --Mar. 5, 1996 (CA)...2171047--.

Column 14, Line 55 “on the other surface” should read --on the outer surface--.

Claim 21, Column 16, line 4, “in the expandable portion” should read --on the expandable portion--.

Claim 47, Column 17, Line 26 “or an adjacent” should read --on an adjacent--.

Column 18, Line 14 “disposed in the expandable portion” should read --disposed on the expandable portion--.

Signed and Sealed this

Twelfth Day of June, 2007

A handwritten signature in black ink on a light gray dotted background. The signature reads "Jon W. Dudas" in a cursive style.

JON W. DUDAS

*Director of the United States Patent and Trademark Office*



UNITED STATES PATENT AND TRADEMARK OFFICE  
**CERTIFICATE OF CORRECTION**

PATENT NO. : 6,881,223 B2  
APPLICATION NO. : 10/190818  
DATED : April 19, 2005  
INVENTOR(S) : Ian M. Penn et al.

Page 1 of 1

It is certified that error appears in the above-identified patent and that said Letters Patent is hereby corrected as shown below:

This certificate supersedes Certificate of Correction issued June 12, 2007. The certificate should be vacated since Certificate of Correction is a duplicate of Certificate of Correction issued May 29, 2007.

Signed and Sealed this

Thirty-first Day of July, 2007

A handwritten signature in black ink on a light gray dotted background. The signature reads "Jon W. Dudas" in a cursive style.

JON W. DUDAS

*Director of the United States Patent and Trademark Office*