



US006880370B2

(12) **United States Patent**
Yu

(10) **Patent No.:** **US 6,880,370 B2**
(45) **Date of Patent:** **Apr. 19, 2005**

(54) **NUMERAL LOCK HOUSING STRUCTURE**

(76) Inventor: **Chun-Te Yu**, No. 41-21, Kuan-Tsui St.,
Hsia-Nien Tsun, Fu-Hsing Hsiang,
Changhua County (TW)

(*) Notice: Subject to any disclaimer, the term of this
patent is extended or adjusted under 35
U.S.C. 154(b) by 4 days.

(21) Appl. No.: **10/679,425**

(22) Filed: **Oct. 7, 2003**

(65) **Prior Publication Data**

US 2005/0044900 A1 Mar. 3, 2005

(30) **Foreign Application Priority Data**

Aug. 28, 2003 (TW) 92215596 U

(51) **Int. Cl.**⁷ **E05B 37/06**

(52) **U.S. Cl.** **70/25; 70/26; 70/312**

(58) **Field of Search** **70/22-30, 312-316**

(56) **References Cited**

U.S. PATENT DOCUMENTS

494,541 A *	4/1893	Baron	70/26
859,614 A *	7/1907	Paddock	70/25
986,595 A *	3/1911	Sage	70/25
1,426,978 A *	8/1922	Gambino	70/25
1,545,666 A *	7/1925	Hornhaber et al.	70/26
1,643,752 A *	9/1927	Rosenhahn	70/25
3,386,271 A *	6/1968	Morin	70/25

4,803,856 A *	2/1989	Ling	70/28
5,396,785 A *	3/1995	Chen	70/25
5,868,012 A *	2/1999	Chun-Te et al.	70/30
5,918,489 A *	7/1999	Yang	70/28
6,029,481 A *	2/2000	Lai	70/25
6,363,758 B1 *	4/2002	Ling	70/30
6,449,992 B1 *	9/2002	Yu et al.	70/58
6,470,717 B1 *	10/2002	Yu	70/25
6,615,626 B1 *	9/2003	Yu et al.	70/301

* cited by examiner

Primary Examiner—Suzanne Dino Barrett

(74) *Attorney, Agent, or Firm*—Troxell Law Office PLLC

(57) **ABSTRACT**

A numeral lock housing structure including a lock housing composed of two halves mated with each other. Each of the halves is formed with at least one lateral face and a front face forward extending from the lateral face. Two edges of the front faces form two mating edges mated with each other. A corner section between the lateral face and the front face of at least one of the two halves is formed with at least one numeral wheel window. At least one numeral wheel is mounted in the numeral wheel window for controlling a lock bolt to lock/unlock the numeral lock. The numeral wheel window extends into the front face without crossing the mating edge thereof. Therefore, the mating edges of the two halves of the lock housing will not be slotted so that the structure of the front face of the lock housing is kept integrated. The numeral wheel is positioned between the lateral face and front face so that the numeral wheel has larger turning angle each time the numeral wheel is turned.

2 Claims, 3 Drawing Sheets

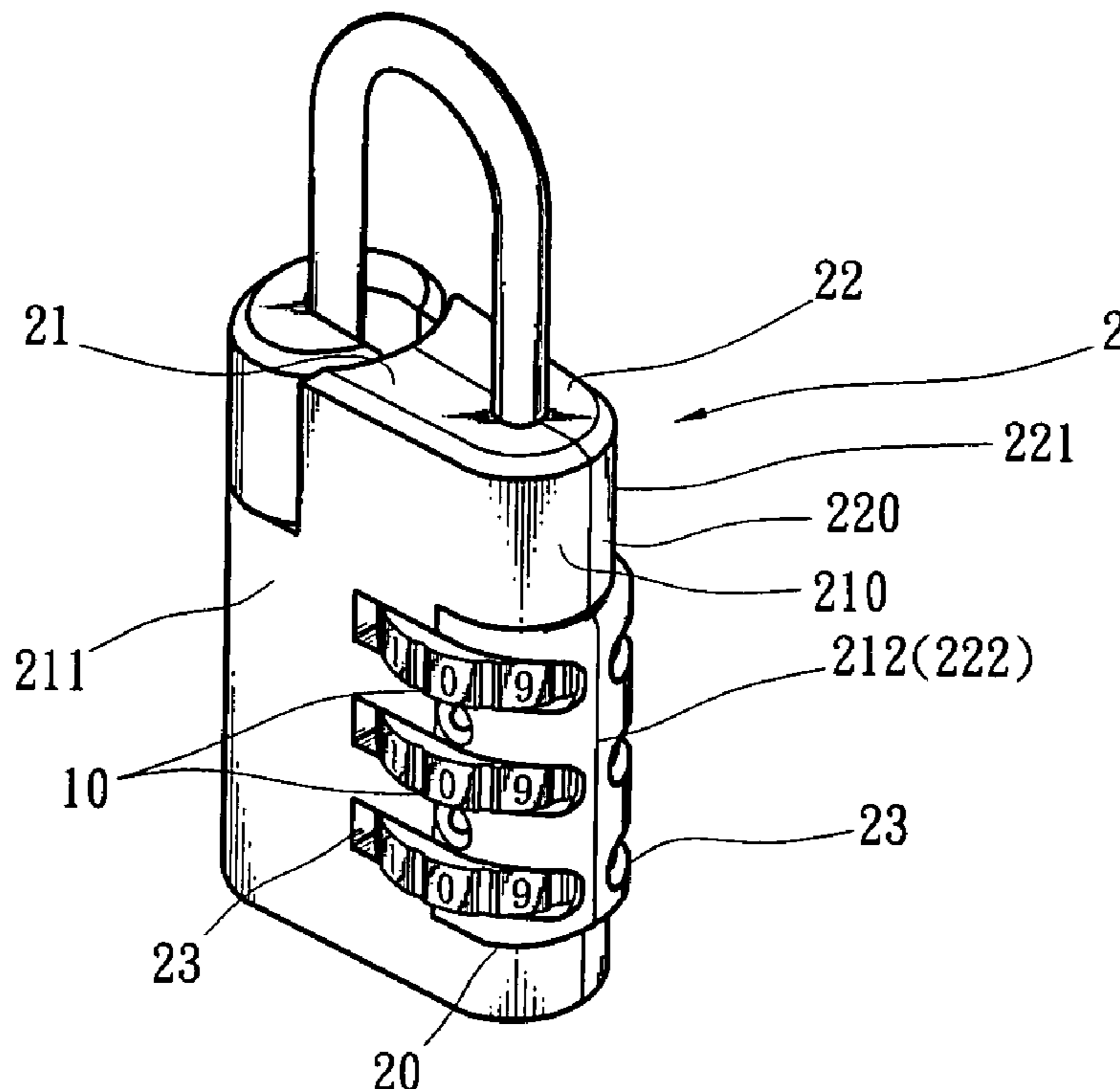

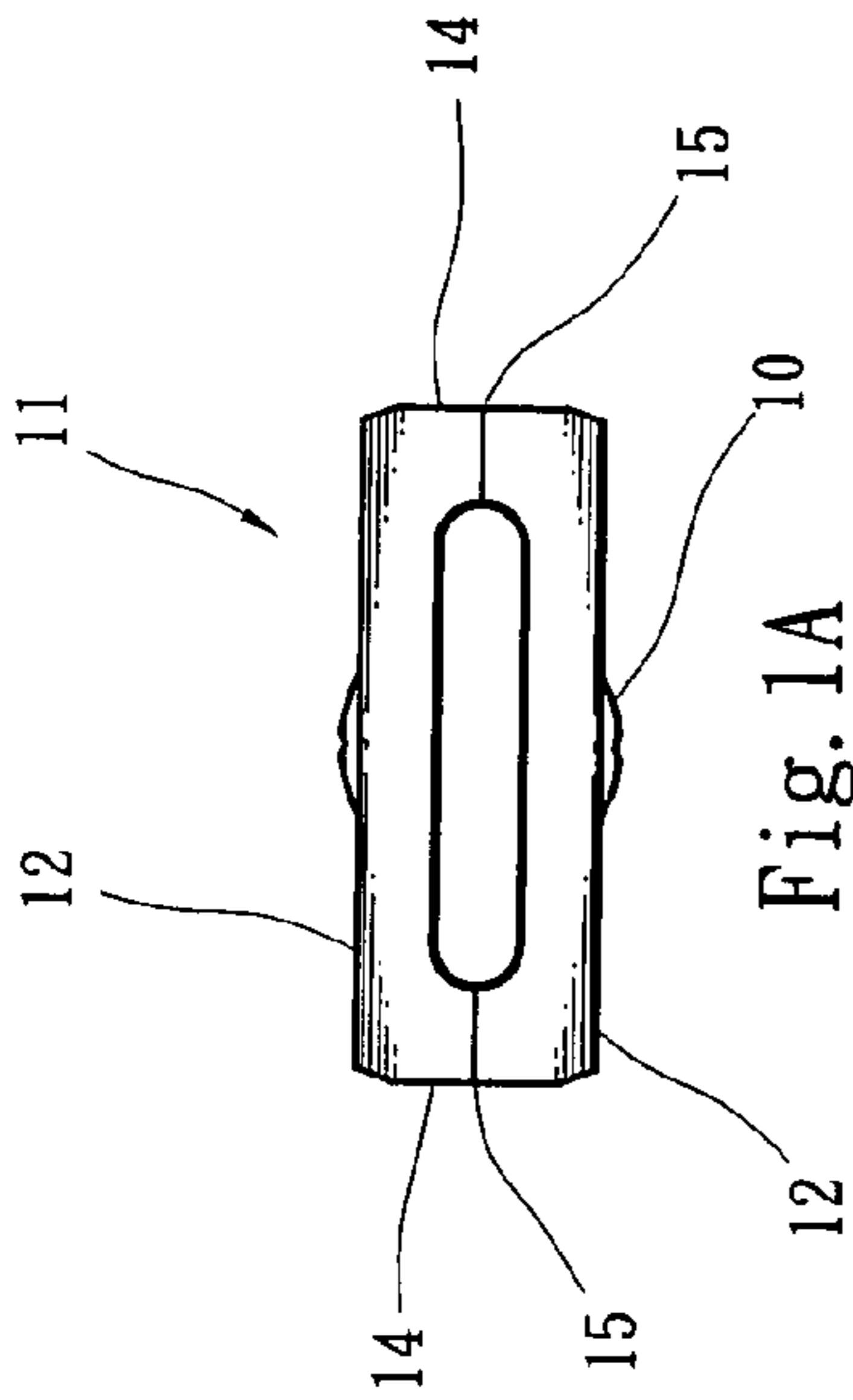

Fig. 1A
PRIOR ART

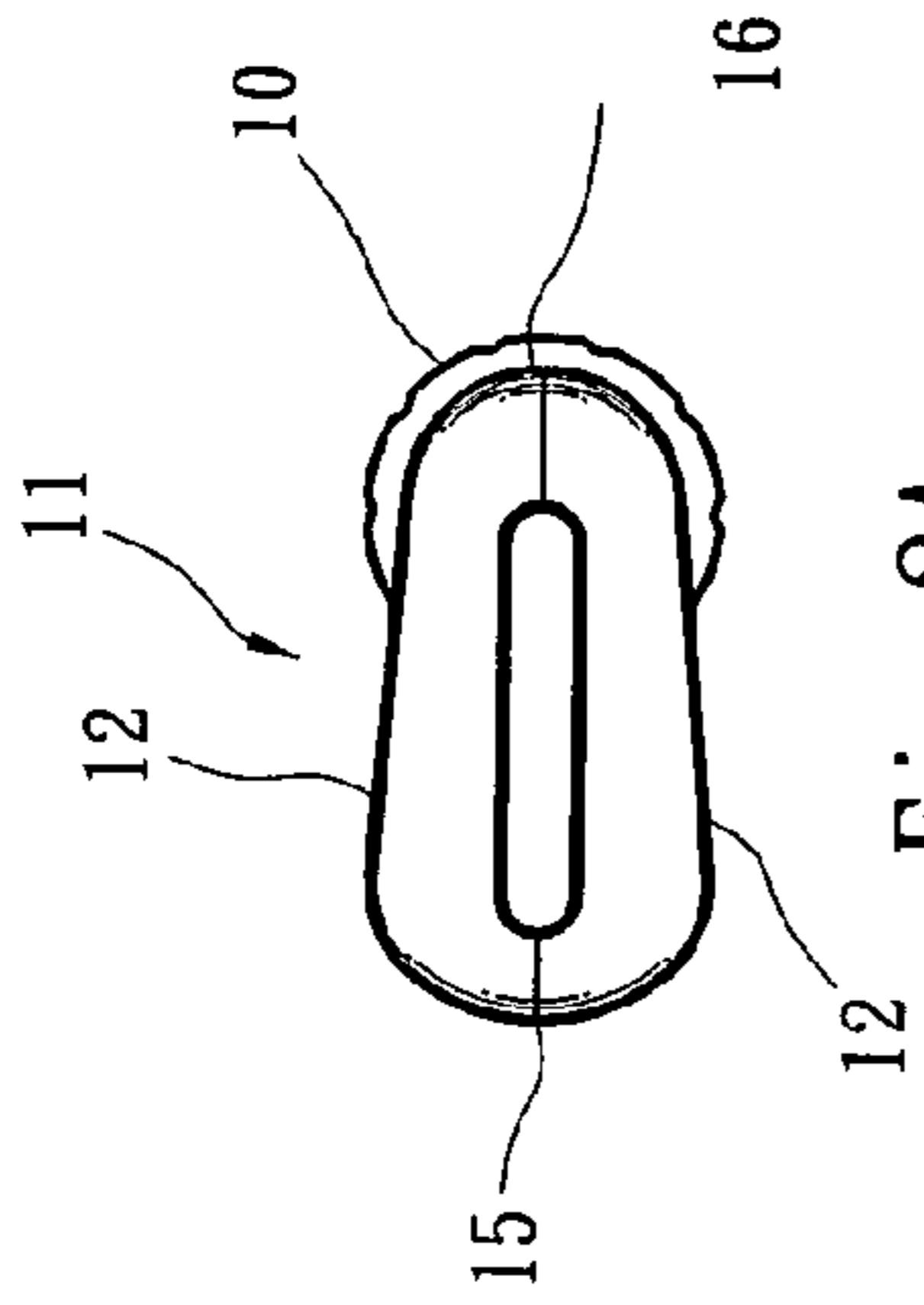

Fig. 2A
PRIOR ART

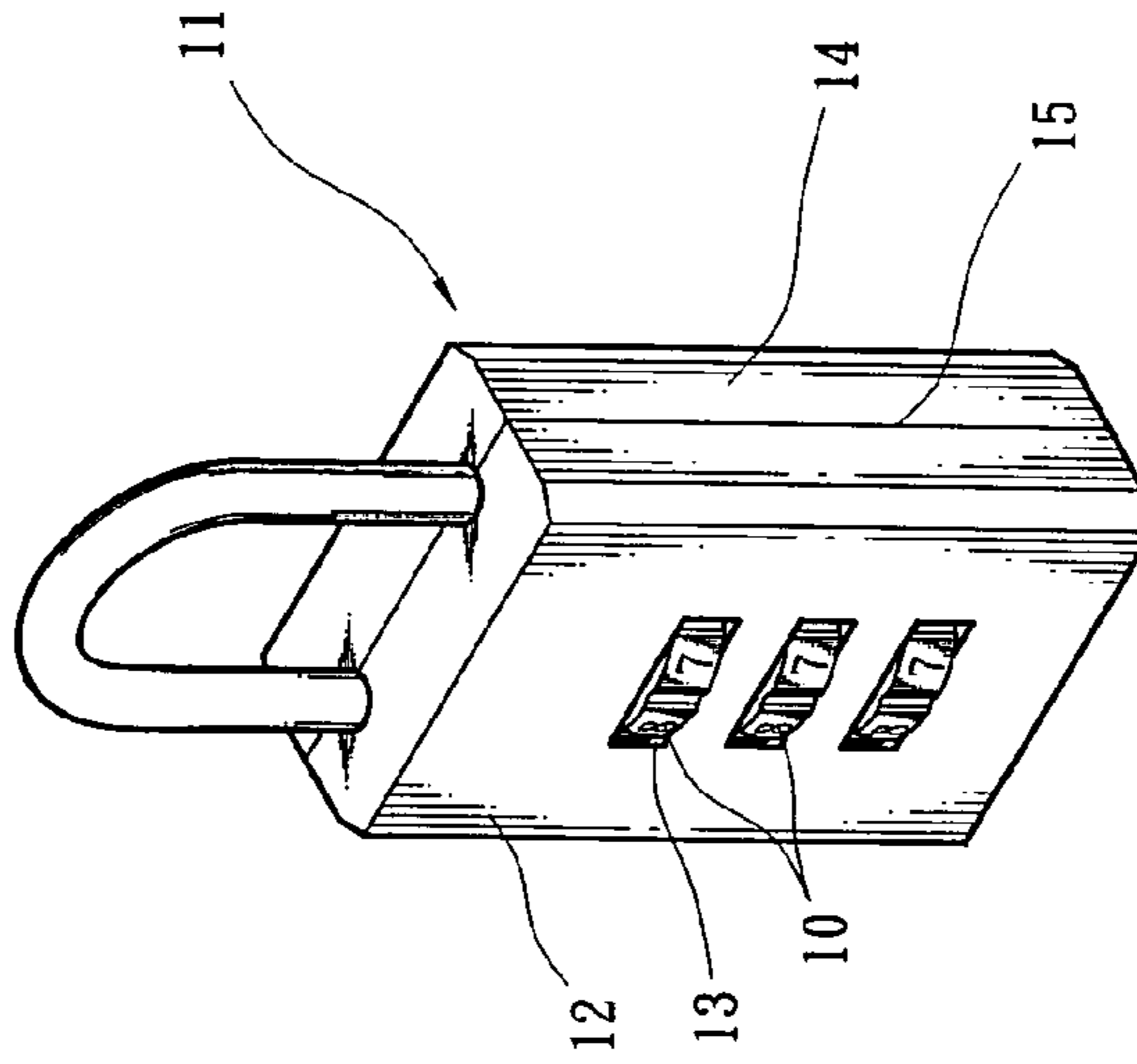

Fig. 1
PRIOR ART

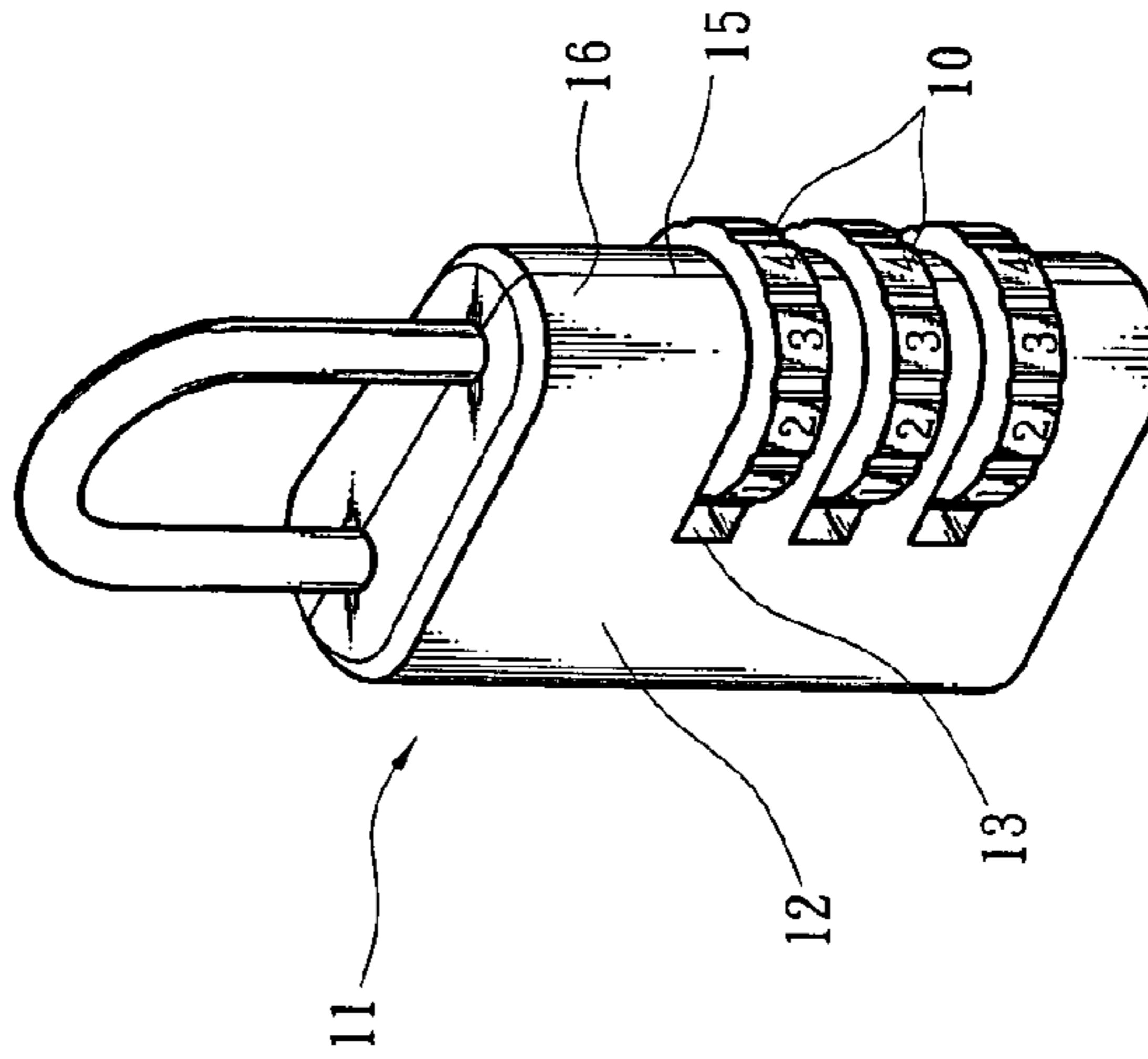
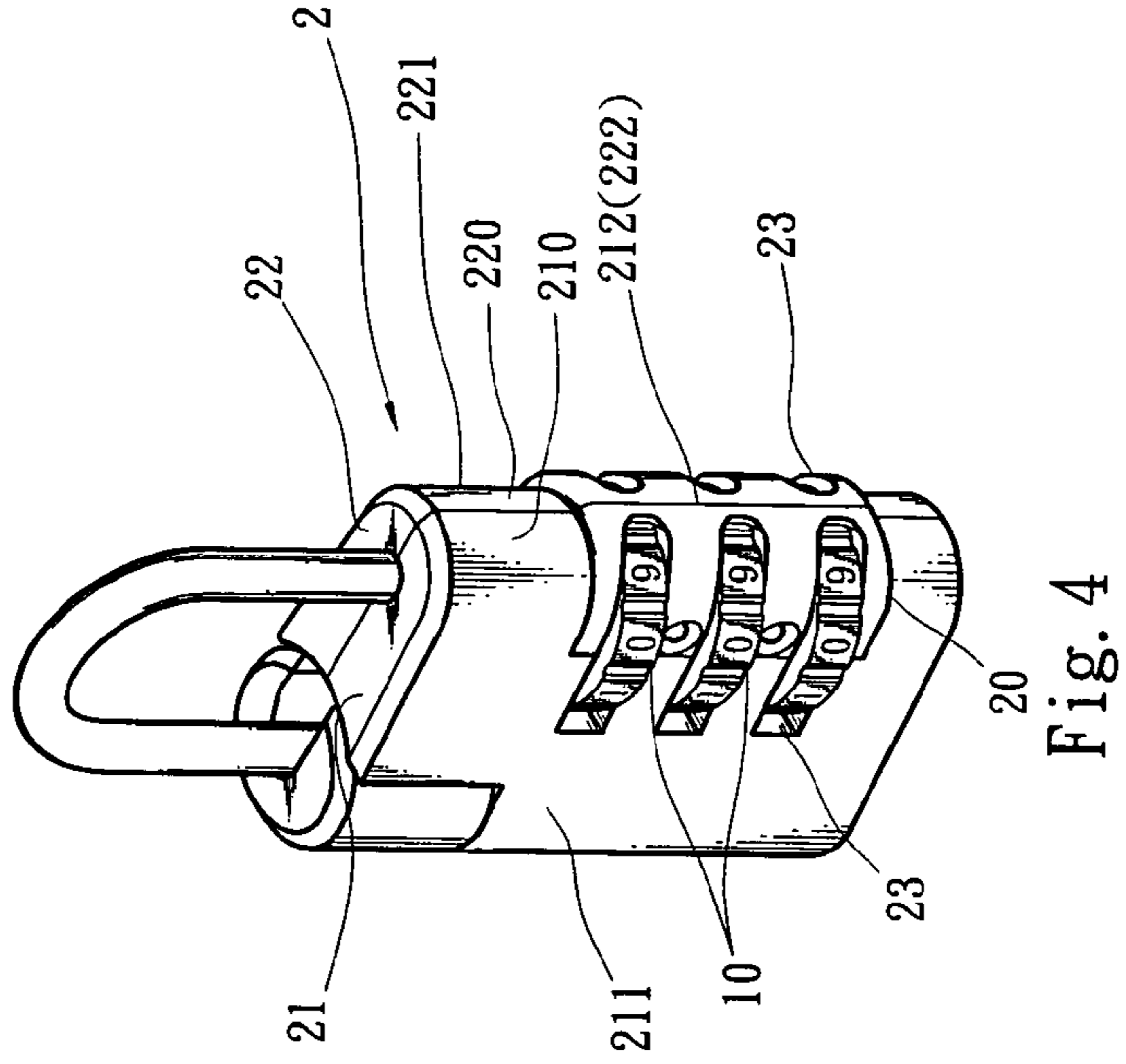
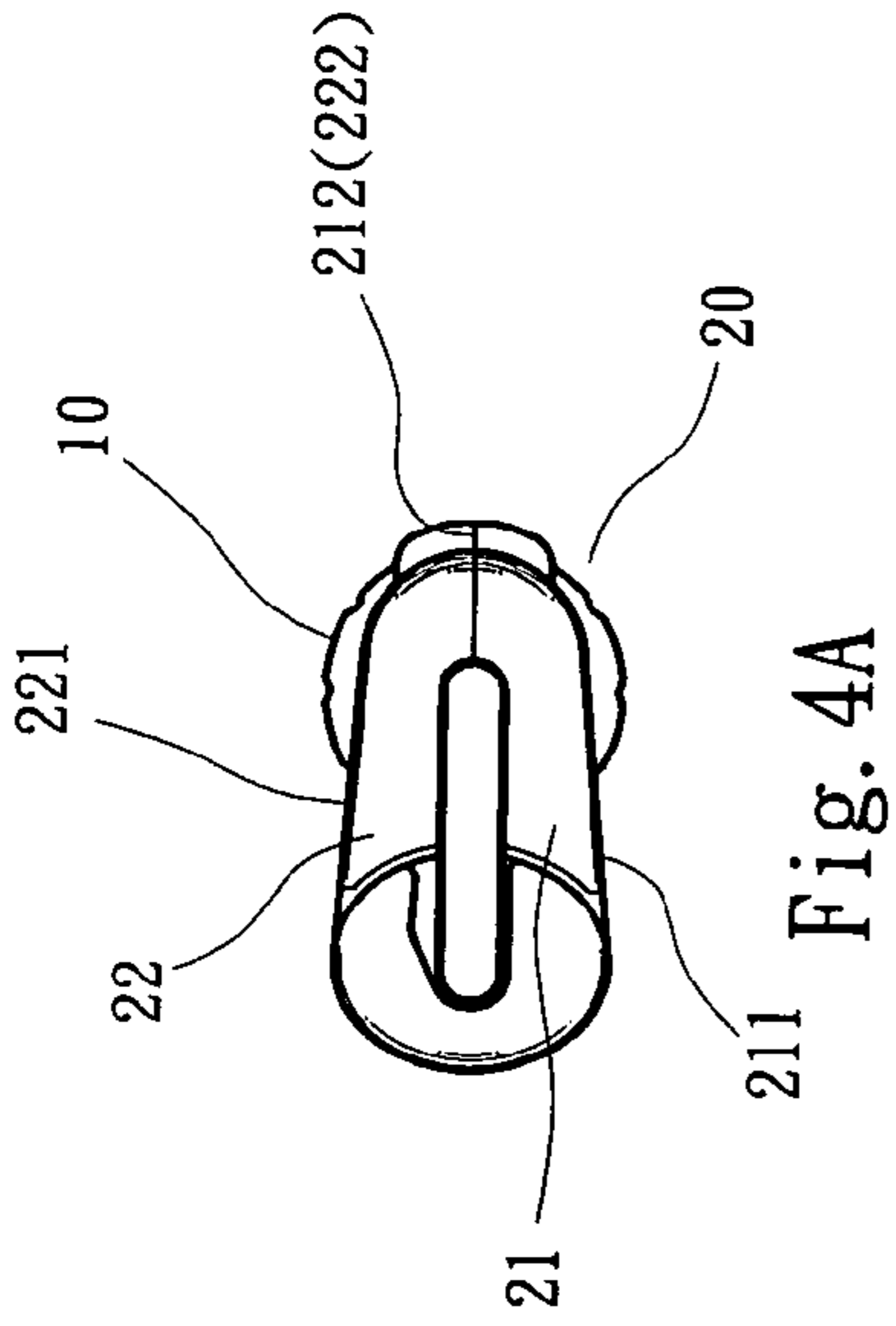
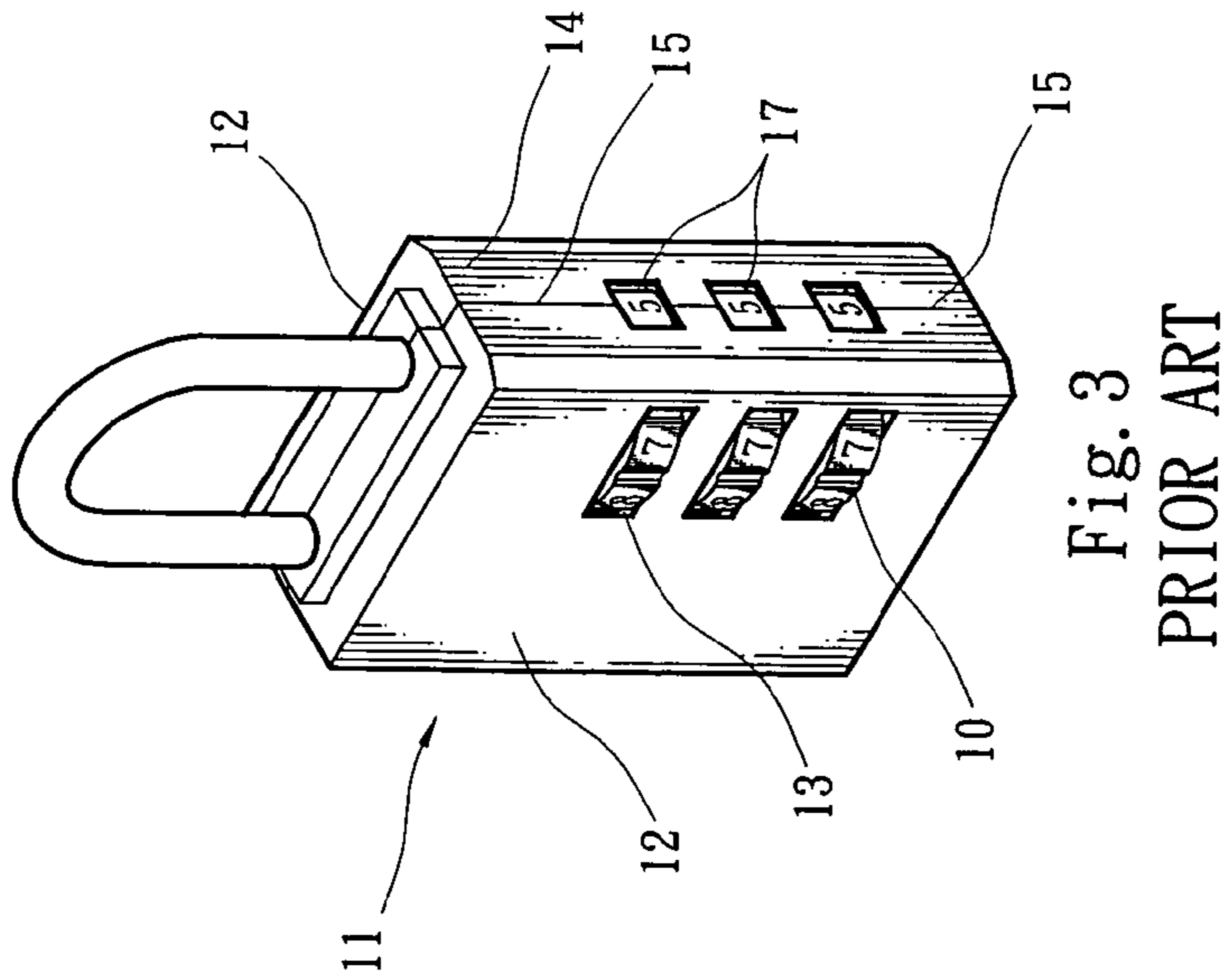
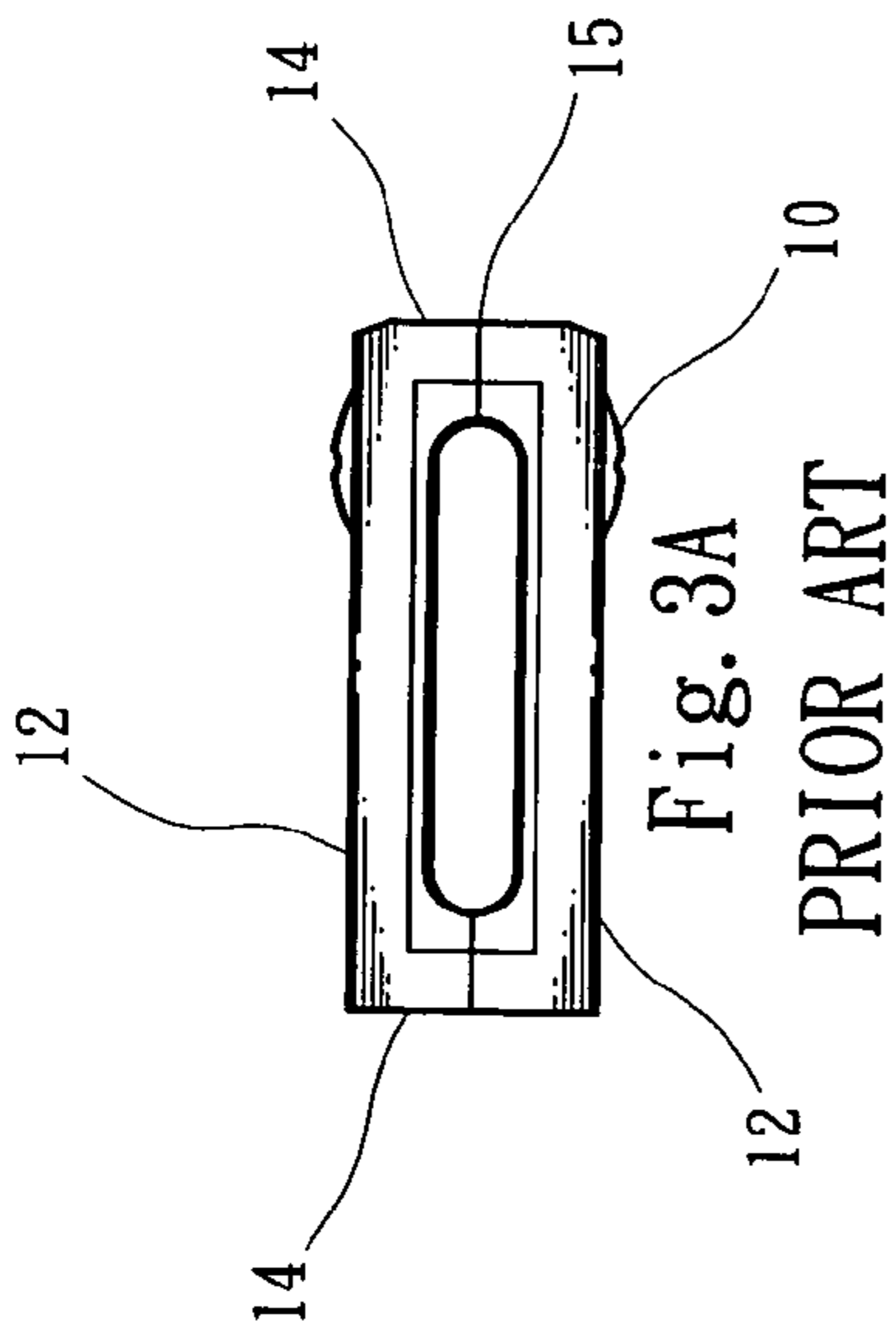

Fig. 2
PRIOR ART



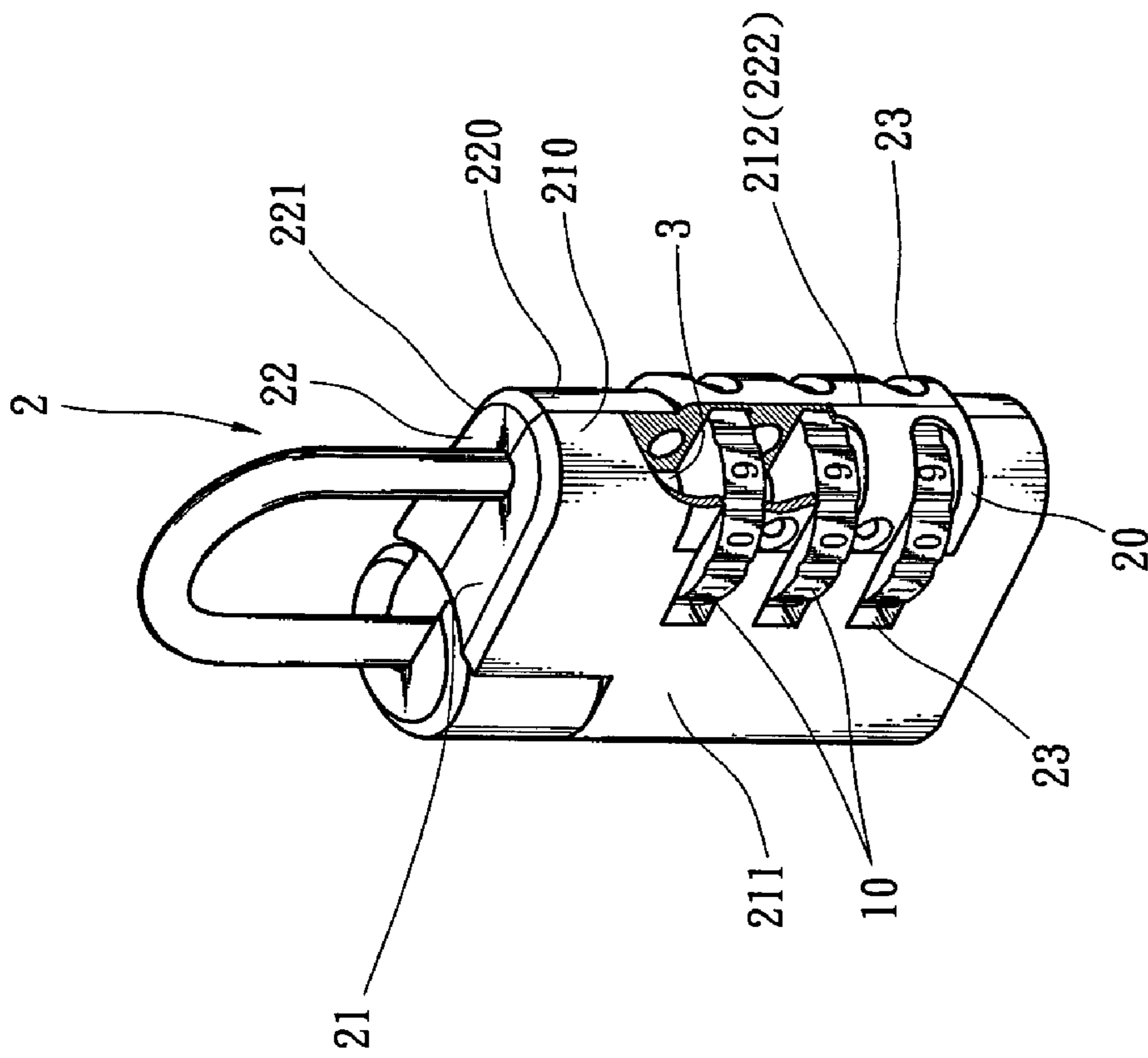

Fig. 5

NUMERAL LOCK HOUSING STRUCTURE

BACKGROUND OF THE INVENTION

The present invention is related to an improved numeral lock housing structure in which the numeral wheel window is re-designed and formed between the lateral face and front face of the lock housing. The numeral wheel window extends into the front face without crossing the mating edge thereof. Therefore, the mating edges of the two halves of the lock housing will not be slotted so that the structure of the front face of the lock housing is kept integrated. In addition, the numeral wheel is positioned in the corner between the lateral face and front face so that the numeral wheel has larger turning angle each time the numeral wheel is turned.

FIG. 1 shows a conventional numeral lock. Several numeral wheel windows **13** are formed on a lateral face **12** of the lock housing **11**. Several numeral wheels **10** are disposed in the windows **13**. The mating edges **15** of the front faces of the lock housing **11** are not interrupted by the windows **13**. Therefore, the front faces of the lock housing **11** is integrated and is not subject to damage of alien article or external force. However, the numeral wheels **10** are presented only on single lateral face of the lock housing **11**. Therefore, the numeral wheel has greatly limited turning angle each time the numeral wheel is turned. As a result, it is necessary to many times turn the numeral wheel for unlocking the numeral lock. This is quite inconvenient.

FIG. 2 shows another type of conventional numeral lock. The numeral wheels **10** are directly bridged over the front face **16** of the lock housing **11** between two lateral faces **12** thereof. Therefore, the mating edges **15** of the lock housing **11** are interrupted. Accordingly, the structural strength of the lock housing **11** is weakened. Also, an alien piece can be easily extended into the lock housing **11** to damage the same. In addition, the numeral wheels **10** are apt to be collided and damaged. As a result, the strength and reliability of the numeral lock as a whole are poor. However, the numeral wheel **10** has larger turning angle each time the numeral wheel **10** is turned so that the operation of the numeral lock is facilitated.

FIG. 3 shows still another type of conventional numeral lock. Several numeral wheel windows **17** are formed on the front face **14** of the lock housing **11** corresponding to the numeral wheels **10**. Such numeral wheel windows **17** facilitate identification of the unlocking number of the numeral wheels **10**. However, the mating edges **15** of the lock housing **11** are interrupted and the structural strength of the lock housing **11** is weakened. In addition, the numeral wheel **10** has small turning angle each time the numeral wheel **10** is turned.

SUMMARY OF THE INVENTION

It is therefore a primary object of the present invention to provide an improved numeral lock housing structure including a lock housing composed of two halves mated with each other. Each of the halves is formed with at least one lateral face and a front face forward extending from the lateral face. A corner section between the lateral face and the front face of at least one of the two halves is formed with at least one numeral wheel window. The numeral wheel window extends into the front face without crossing the mating edge thereof. Therefore, the mating edges of the two halves of the lock housing will not be interrupted so that the structure of the front face of the lock housing is kept integrated.

It is a further object of the present invention to provide the above numeral lock housing structure in which the numeral wheel window is bridged between the lateral face and the front face of the lock housing so that the numeral wheel is positioned between the lateral face and the front face. Therefore, the numeral wheel has larger turning angle each time the numeral wheel is turned so that the operation of the numeral lock is facilitated.

The present invention can be best understood through the following description and accompanying drawings wherein:

BRIEF DESCRIPTION OF THE DRAWINGS

FIG. 1 is a perspective view of a first type of conventional numeral lock;

FIG. 1A is a top view according to FIG. 1;

FIG. 2 is a perspective view of a second type of conventional numeral lock;

FIG. 2A is a top view according to FIG. 2;

FIG. 3 is a perspective view of a third type of conventional numeral lock;

FIG. 3A is a top view according to FIG. 3;

FIG. 4 is a perspective view of a preferred embodiment of the present invention;

FIG. 4A is a top view according to FIG. 4; and

FIG. 5 is a partially sectional perspective view of the preferred embodiment of the present invention.

DETAILED DESCRIPTION OF THE PREFERRED EMBODIMENT

Please refer to FIGS. 4, 4A and 5. The present invention includes a lock housing **2** composed of two halves **21**, **22** mated with each other. Each half **21**, **22** is formed with at least one lateral face **211**, **221** and a front face **210**, **220** forward extending from the lateral face. Two edges **212**, **222** of the front faces **210**, **220** form two mating edges **212**, **222** mated with each other.

A corner section **20** between the lateral face **211**, **221** and the front face **210**, **220** of at least one of the two halves **21**, **22** is formed with at least one numeral wheel window **23**. At least one numeral wheel **4** is mounted in the numeral wheel window **23** for driving a lock bolt **3** disposed in the lock housing **2**. The numeral wheel **4** can be turned from outer side of the lock housing **2** to drive the lock bolt **3**. The lock bolt **3** controls a locking/unlocking unit to lock or unlock the numeral lock.

The numeral wheel window **23** is bridged between the lateral face **211**, **221** and the front face **210**, **220**. In addition, the numeral wheel window **23** extends into the front face **210**, **220** without crossing the mating edges **212**, **222**. That is, the end of the numeral wheel window **23** will not cross and interrupt the mating edges **212**, **222** of the two halves **21**, **22**. Therefore, the strength of the entire lock housing **2** is integrated without being obstructed. Also, no gap is formed between the mating edges **212**, **222** so that it is hard for an unauthorized person to extend an alien piece into the seam to damage the lock housing **2**. Accordingly, the reliability of the numeral lock is enhanced.

Furthermore, the numeral wheel window **23** is positioned in the corner between the lateral face **211**, **221** and the front face **210**, **220**. Therefore, the numeral wheel **4** mounted in the numeral wheel window **23** has larger turning angle to outer side. Accordingly, each time the numeral wheel **4** is turned, the numeral wheel **4** can be turned by a larger angle. Therefore, the operation of the numeral lock is facilitated. In contrast, in the conventional numeral lock, the numeral

3

wheel 4 is presented only on single face and the turning angle of the numeral wheel 4 is apparently insufficient.

According to the above arrangement, the lock housing of the present invention has reliable strength and it is convenient to operate the numeral lock.

The above embodiment is only used to illustrate the present invention, not intended to limit the scope thereof. Many modifications of the above embodiment can be made without departing from the spirit of the present invention.

What is claimed is:

1. A numeral lock housing structure comprising a lock housing composed of two halves mated with each other, each of the halves being formed with at least one lateral face and a front face forward extending from the lateral face, two edges of the front faces forming two mating edges mated with each other, a corner section between the lateral face and the front face of each of the two halves being formed with at least one numeral wheel window, at least one numeral wheel being mounted in the numeral wheel window for driving a locking/unlocking unit disposed in the lock housing, the numeral wheel window extending into the front face

4

without crossing the mating edge thereof, wherein the numeral wheel windows are symmetrically respectively formed on the two halves of the lock housing.

2. A numeral lock housing structure comprising a lock housing composed of two halves mated with each other, each of the halves being formed with at least one lateral face and a front face forward extending from the lateral face, two edges of the front faces forming two mating edges mated with each other, a corner section between the lateral face and the front face of each of the two halves being formed with at least one numeral wheel window, at least one numeral wheel being mounted in the numeral wheel window for driving a locking/unlocking unit disposed in the lock housing, the numeral wheel window extending into the front face without crossing the mating edge thereof, wherein the locking/unlocking unit is controlled by a lock bolt drivingly connected with the numeral wheel, wherein the numeral wheel windows are symmetrically respectively formed on the two halves of the lock housing.

* * * * *