



US006875968B2

(12) **United States Patent**  
**Lee et al.**

(10) **Patent No.:** **US 6,875,968 B2**  
(45) **Date of Patent:** **\*Apr. 5, 2005**

(54) **METHOD OF CONTROLLING MICROWAVE OVEN**

4,791,263 A \* 12/1988 Groeschel, Jr. .... 219/707  
4,864,088 A \* 9/1989 Hiejima et al. .... 219/707  
6,279,464 B1 8/2001 Lo et al.

(75) Inventors: **Sung-Ho Lee**, Suwon (KR); **Chul Kim**, Seongnam (KR); **Young-Won Cho**, Suwon (KR); **Tae-Soo Kim**, Seoul (KR)

**FOREIGN PATENT DOCUMENTS**

GB 2 255 205 \* 10/1992 ..... 219/707  
JP 53-137446 \* 11/1978 ..... 219/707  
JP 3-110323 \* 5/1991 ..... 219/707

(73) Assignee: **Samsung Electronics Co., Ltd.**, Suwon-Si (KR)

**OTHER PUBLICATIONS**

(\*) Notice: Subject to any disclaimer, the term of this patent is extended or adjusted under 35 U.S.C. 154(b) by 0 days.

U.S. Appl. No. 10/189,588, filed Jul. 8, 2002, Sung-Ho Lee et al., Samsung Electronics Co., Ltd.

U.S. Appl. No. 10/189,590, filed Jul. 8, 2002, Sung-Ho Lee et al., Samsung Electronics Co., Ltd.

This patent is subject to a terminal disclaimer.

\* cited by examiner

(21) Appl. No.: **10/189,559**

*Primary Examiner*—Philip H. Leung

(22) Filed: **Jul. 8, 2002**

(74) *Attorney, Agent, or Firm*—Staas & Halsey

(65) **Prior Publication Data**

(57) **ABSTRACT**

US 2003/0146208 A1 Aug. 7, 2003

A method of controlling a microwave oven, in which the microwave oven includes a cooking chamber for containing food therein, a cooling fan which circulates air, a magnetron which generates microwaves and a humidity sensor which senses humidity of the cooking chamber. Cooking instruction(s) may be preset or set manually by a user. A first cooking operation is performed while preventing water from boiling off/to overflow by controlling an output power of the magnetron according to the set cooking instruction(s). A time required to perform a second cooking operation is set based on a time required to perform the first cooking operation. The second cooking operation is performed for the second cooking time while steam boiling the food.

(30) **Foreign Application Priority Data**

Feb. 6, 2002 (KR) ..... 2002-6694

(51) **Int. Cl.**<sup>7</sup> ..... **H05B 6/68**

(52) **U.S. Cl.** ..... **219/707; 219/719; 219/705; 99/325**

(58) **Field of Search** ..... 219/707, 719, 219/702, 704, 705, 757, 492; 99/325, 451

(56) **References Cited**

**U.S. PATENT DOCUMENTS**

4,692,597 A \* 9/1987 Tsuda et al. .... 219/719

**24 Claims, 7 Drawing Sheets**

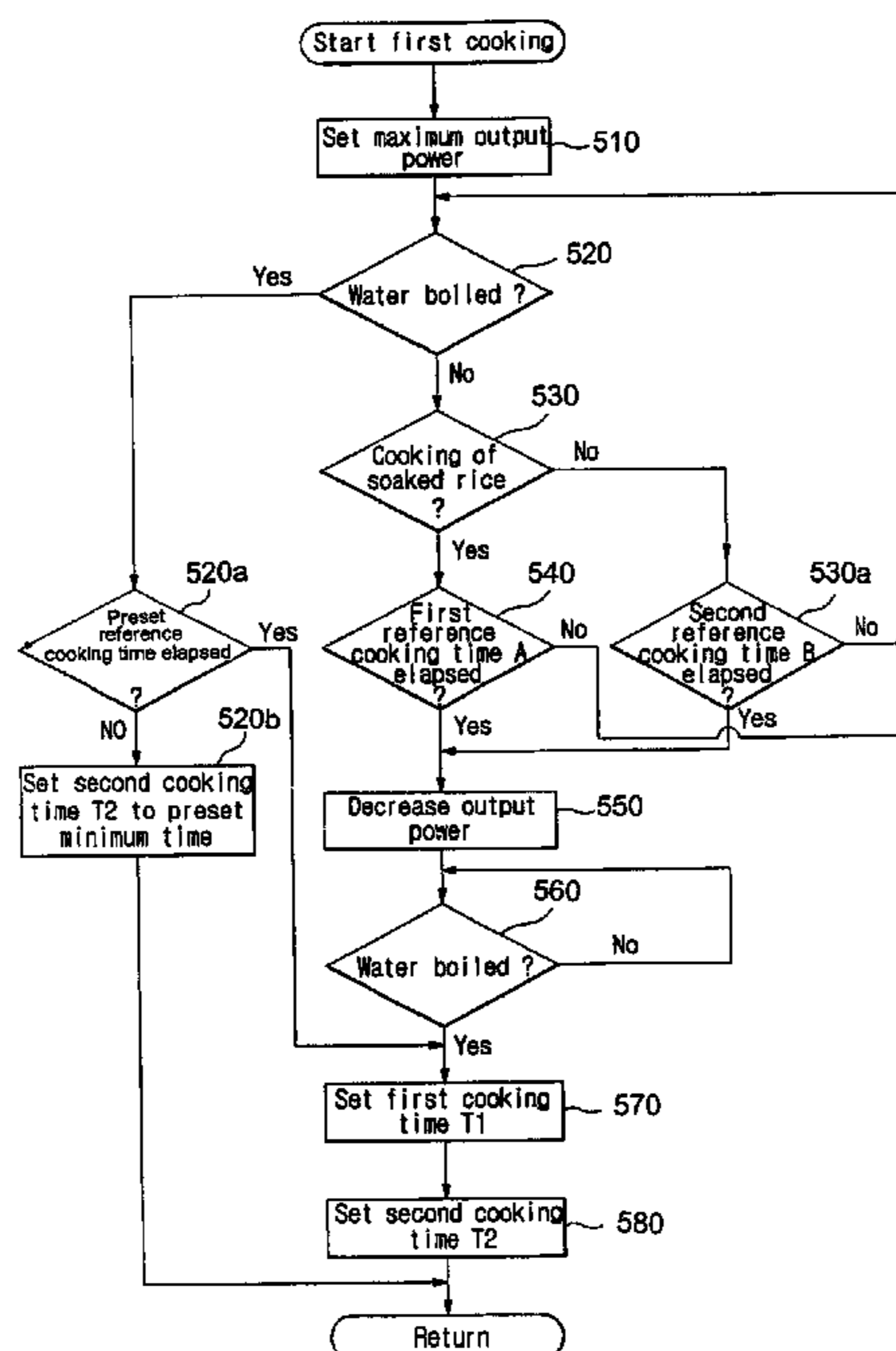

FIG. 1

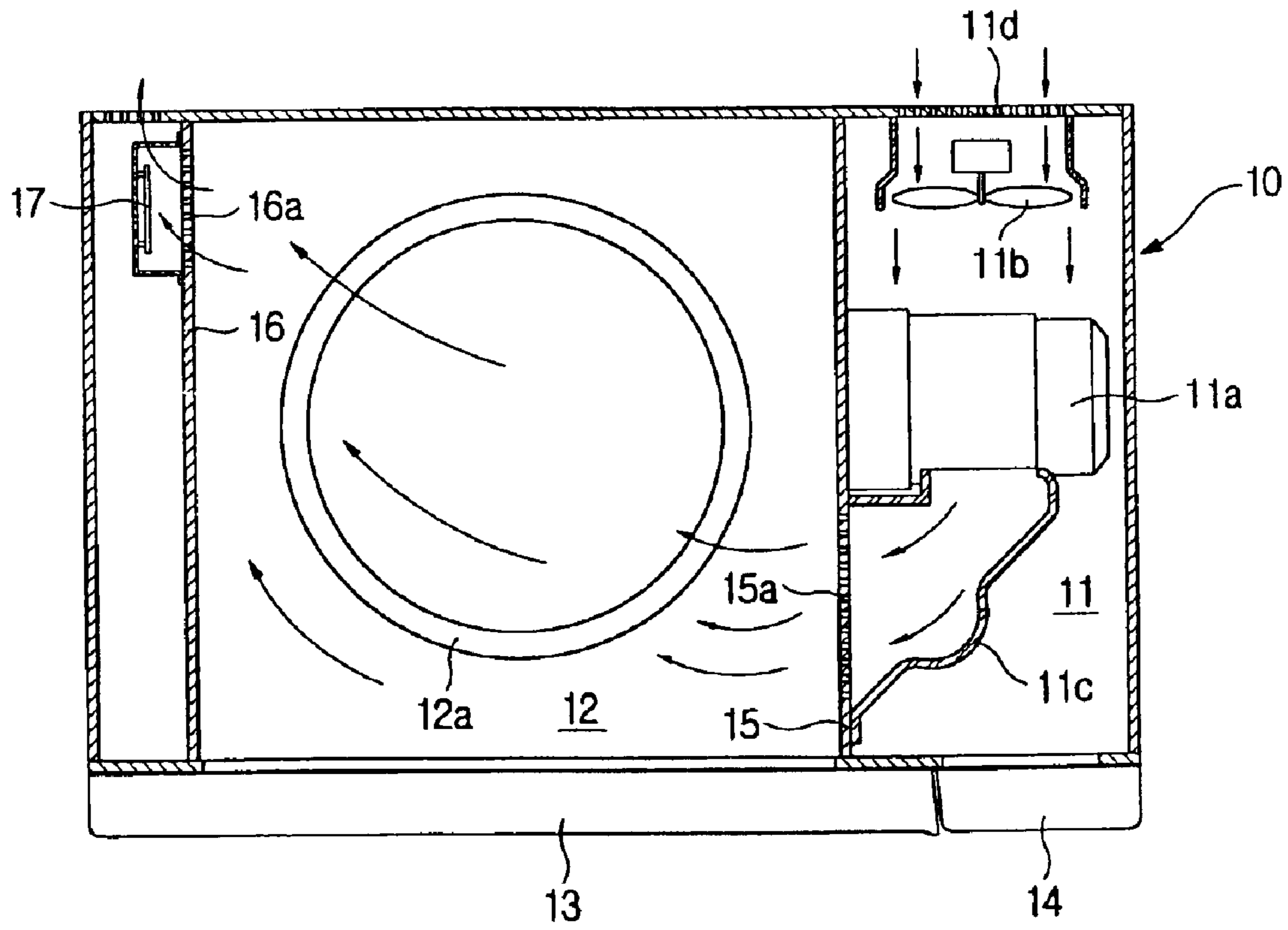

FIG. 2

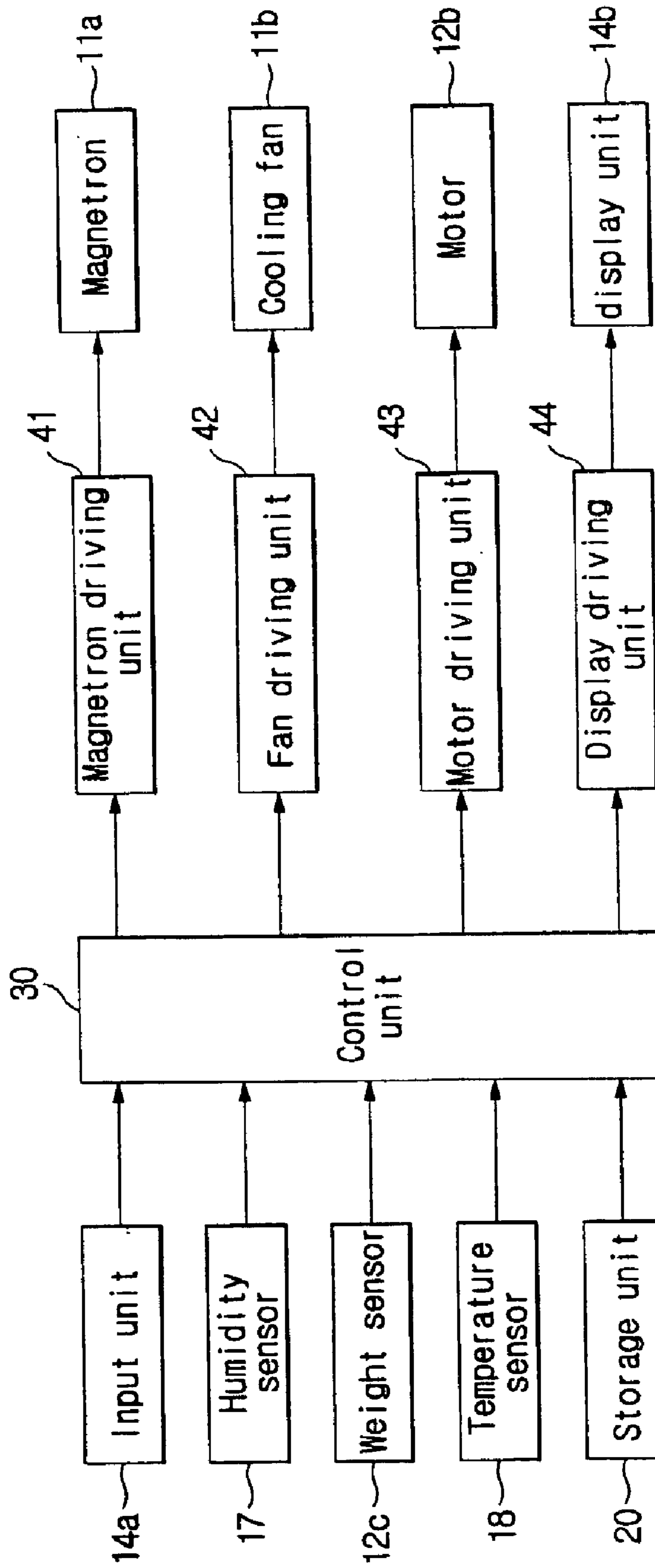

FIG. 3A

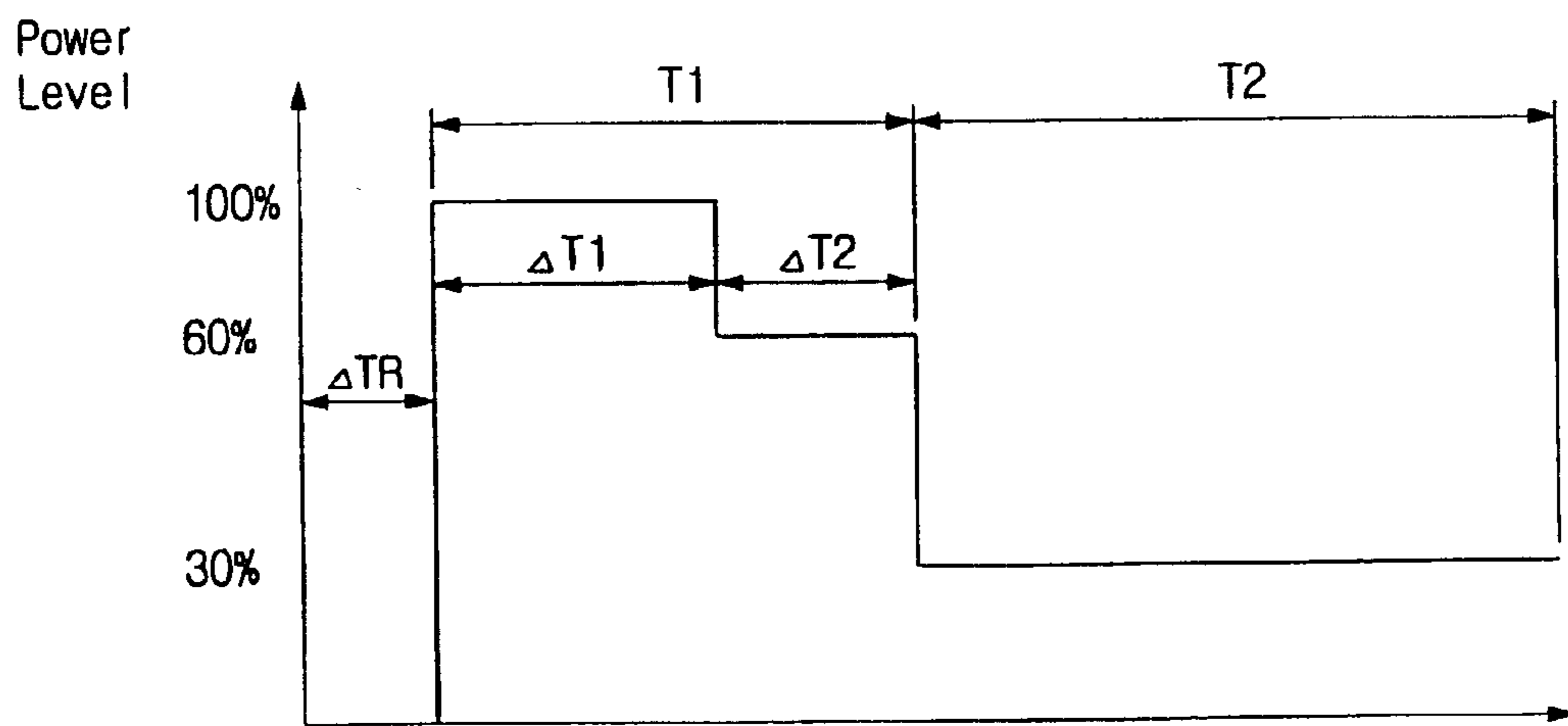

FIG. 3B

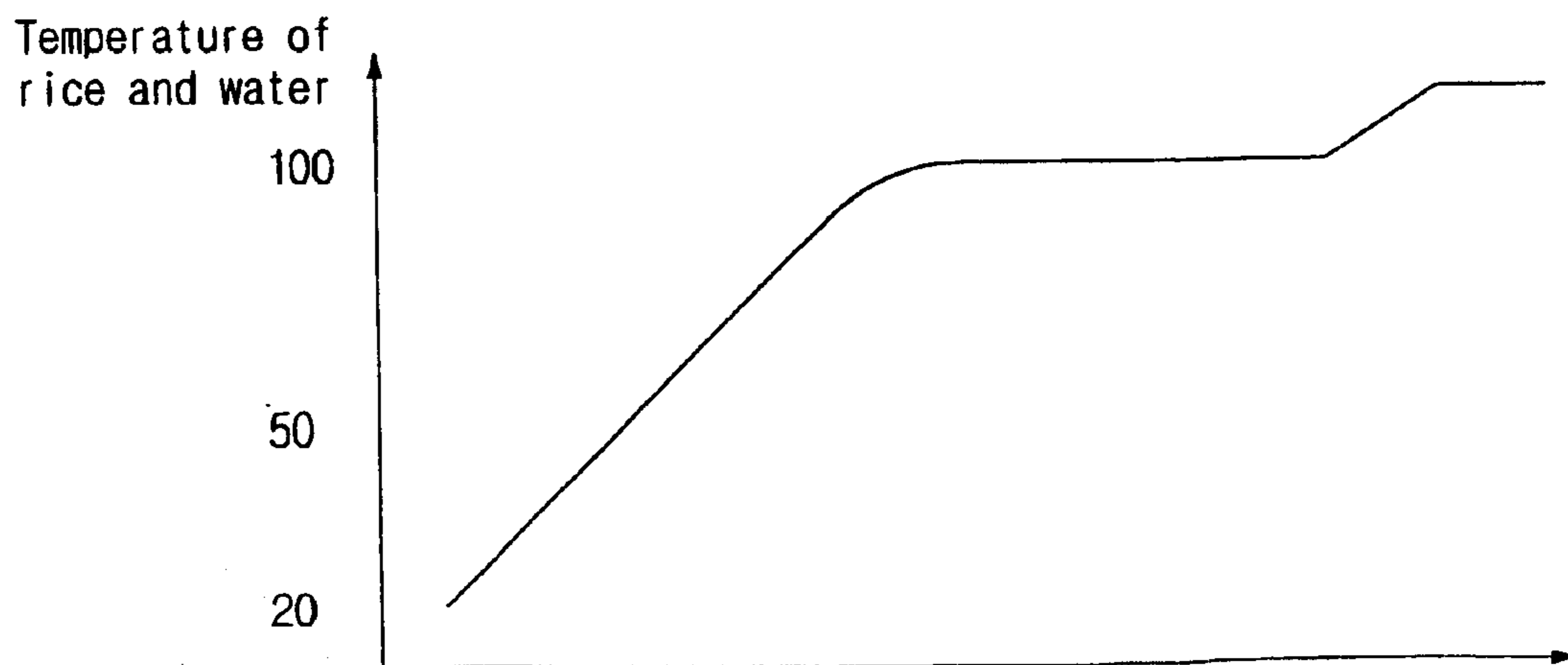

FIG. 4

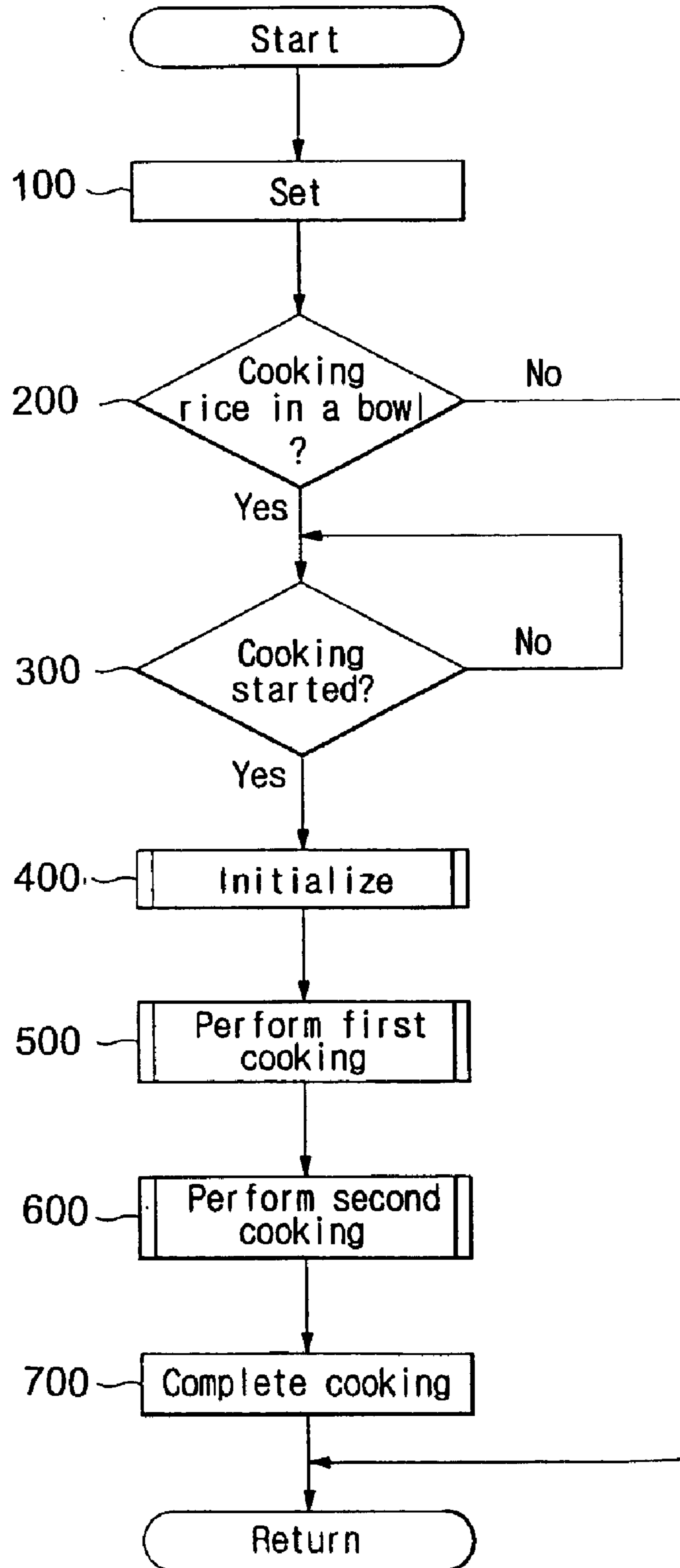

FIG. 5

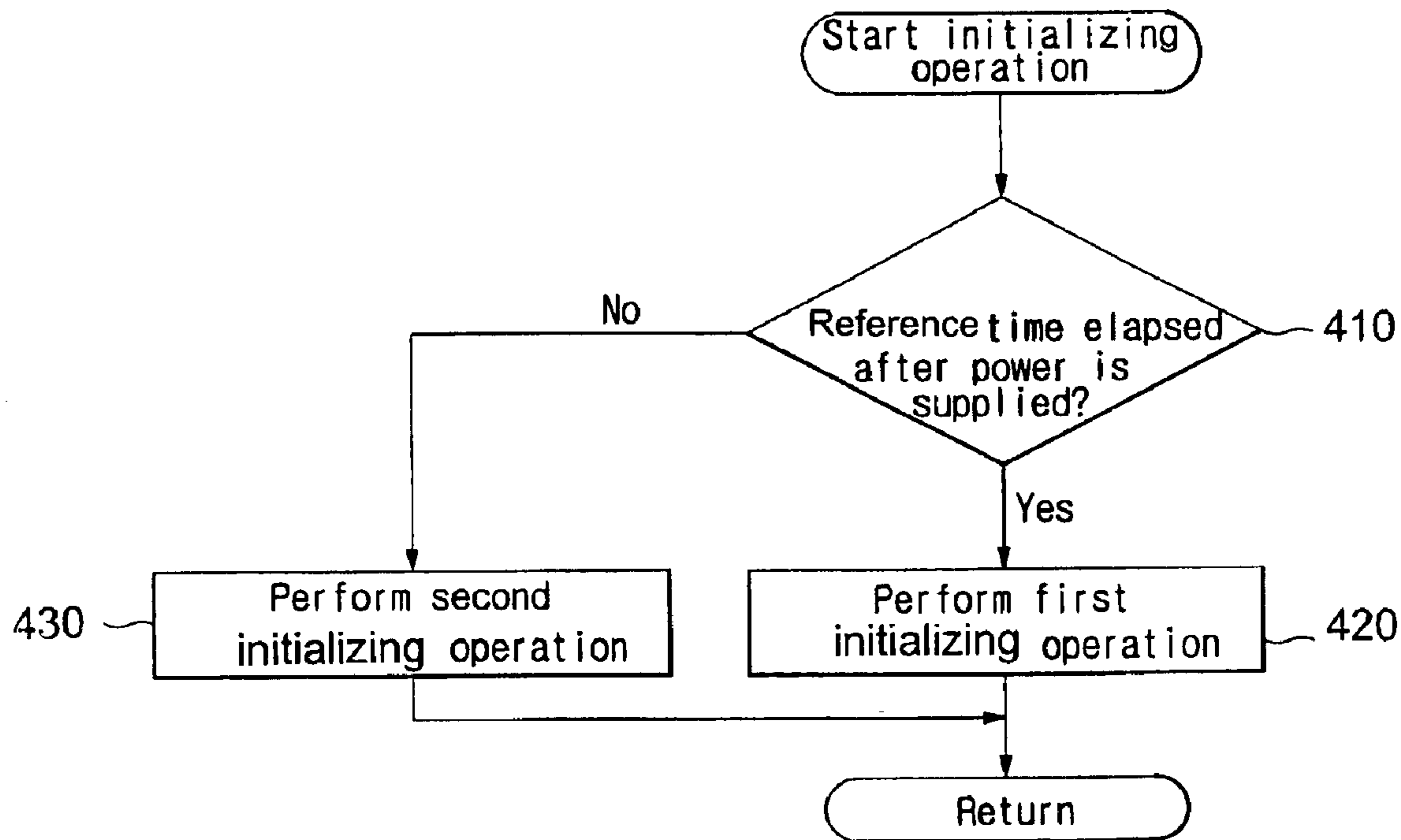

FIG. 6

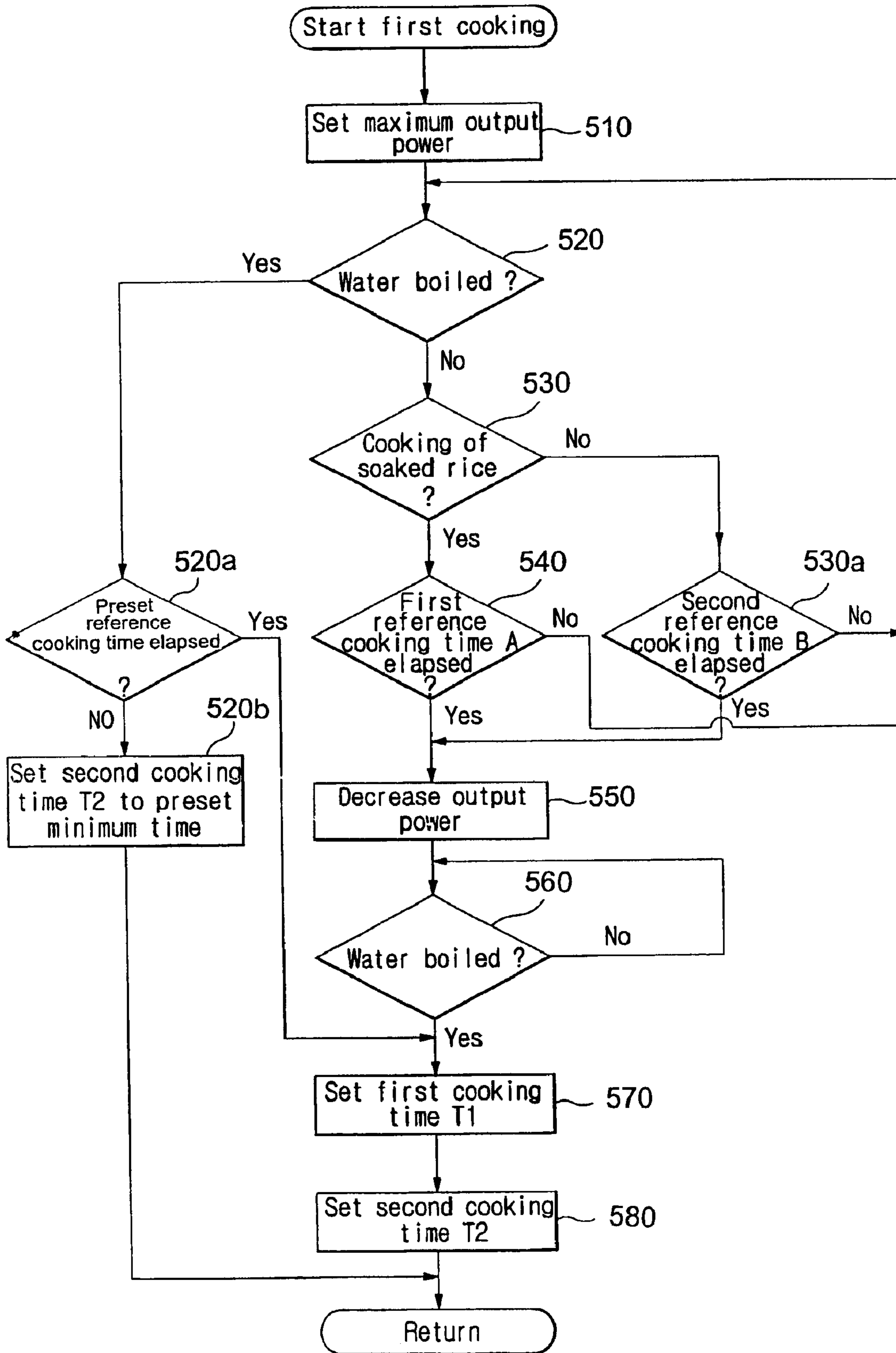
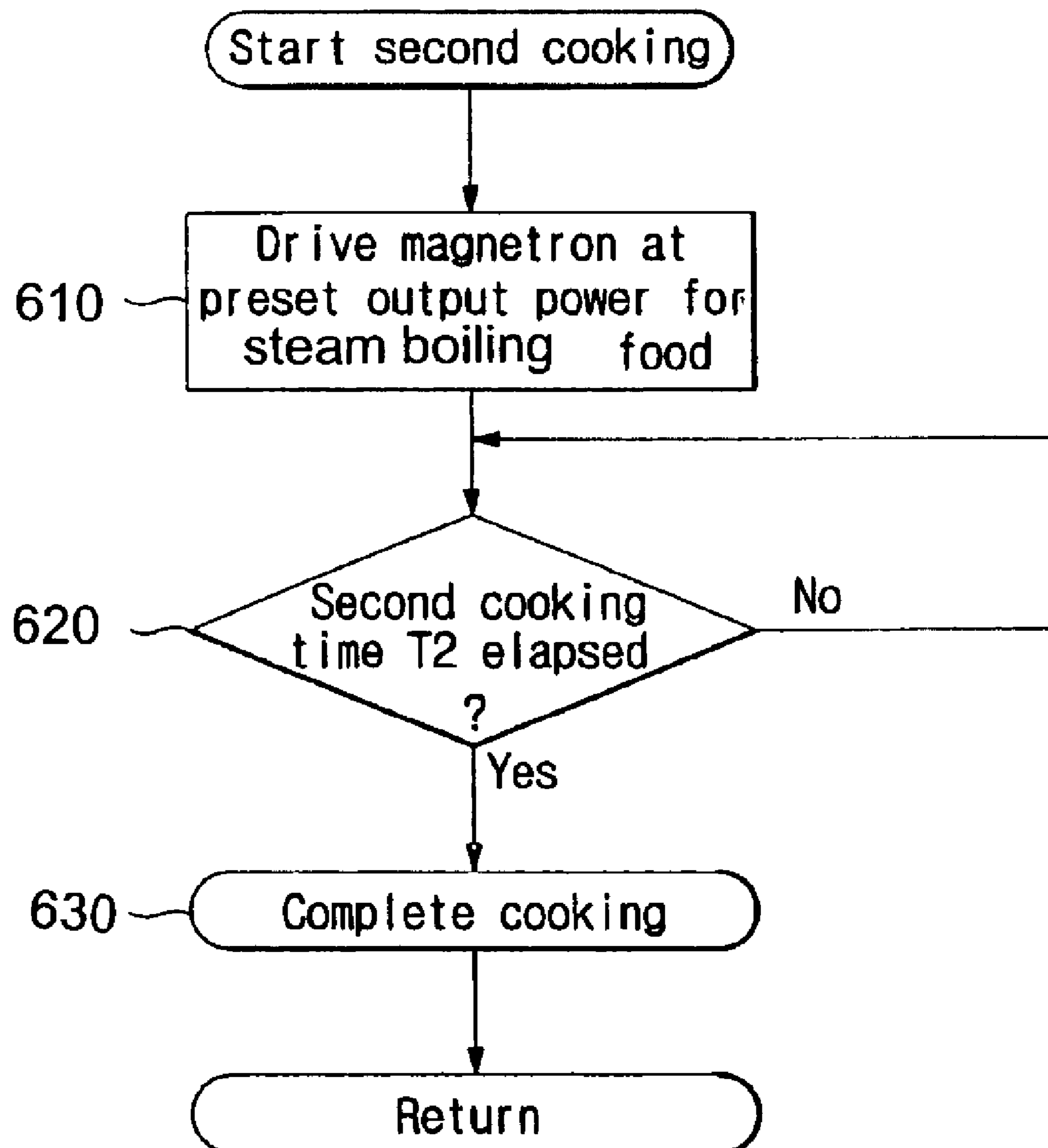

FIG. 7





# METHOD OF CONTROLLING MICROWAVE OVEN

## CROSS-REFERENCE TO RELATED APPLICATIONS

This application claims the benefit of Korean Patent Application No. 2002-6694 filed on Feb. 6, 2002, in the Korean Industrial Property Office, the disclosure of which is incorporated herein by reference.

## BACKGROUND OF THE INVENTION

### 1. Field of the Invention

The present invention relates to a method of controlling a microwave oven, which can cook rice in a bowl.

### 2. Description of the Related Art

Generally, a microwave oven is a machine which cooks foods by the frictional heat of water molecules in the foods. The microwave oven radiates microwaves of 2450 MHz to a cooking chamber using a magnetron to repeatedly change a molecular arrangement of the water contained in the foods. In order to satisfy various requirements of customers, some of the microwave ovens are equipped with a humidity sensor which allows the microwave ovens to automatically cook food by sensing a water vapor generated from the food.

A conventional microwave oven may also have cooking menus to cook rice. However, a rice cooking menu of the conventional microwave oven is a cooking program based on a general instruction to cook rice for more than two to four people. That is, the conventional microwave oven cannot control the output power of the magnetron to cook rice for one person. Therefore, if a user cooks rice for one person using the conventional microwave oven, water contained with the rice in a container overflows and boils over the container prior to steam boiling the rice. The result is an ineffective cooking operation and rice that is insufficiently cooked or steamed.

## SUMMARY OF THE INVENTION

Accordingly, it is an object of the present invention to provide a method of controlling a microwave oven, which can prevent water from boiling off/to overflow while cooking rice in a bowl.

Additional objects and advantages of the invention will be set forth in part in the description which follows and, in part, will be obvious from the description, or may be learned by practice of the invention.

To achieve the above and other objects of the present invention, there is provided a method of controlling a microwave oven having a cooking chamber for containing food therein, a cooling fan which circulates air, a magnetron which generates microwaves and a humidity sensor which senses humidity of the cooking chamber, the method comprising setting a cooking instruction, performing a first cooking while preventing water from boiling off/to overflow by controlling an output power of the magnetron according to the cooking instruction, setting a second cook time according to a time required to perform the first cooking, and performing a second cooking for the second cook time while steam boiling the food.

## BRIEF DESCRIPTION OF THE DRAWINGS

These and other objects and advantages of the present invention will become apparent and more readily appreci-

ated from the following description of the embodiments, taken in conjunction with the accompanying drawings of which:

FIG. 1 is a cross sectional view of a microwave oven according to an embodiment of the present invention;

FIG. 2 is a block diagram of the microwave oven shown in FIG. 1;

FIGS. 3A and 3B are graphs showing the output power control of the microwave oven of FIGS. 1 and 2 according to the present invention;

FIG. 4 is a flowchart of a method of controlling the microwave oven shown in FIGS. 1 and 2 according to another embodiment of the present invention;

FIG. 5 is a detailed flowchart illustrating an initializing operation of the method of FIG. 4;

FIG. 6 is a detailed flowchart illustrating a first cooking operation of the method of FIG. 4; and

FIG. 7 is a detailed flowchart illustrating a second cooking operation of the method of FIG. 4.

## DETAILED DESCRIPTION OF THE PREFERRED EMBODIMENTS

Reference will now be made in detail to the embodiments of the present invention, examples of which are illustrated in the accompanying drawings, wherein like reference numerals refer to the like elements throughout. The embodiments are described below in order to explain the present invention by referring to the figures.

FIG. 1 shows a microwave oven according to an embodiment of the present invention. The microwave oven comprises a body 10 which constitutes an external shape of the microwave oven and defines a cooking chamber 12 and a machine room 11 partitioned from the cooking chamber 12, a door 13 connected to the body 10 by a hinge (not shown) to selectively open and shut the cooking chamber 12, a control panel 14 installed on the front of the body 10 and provided with a plurality of functional buttons thereon (not shown), and a humidity sensor 17 which senses humidity of the cooking chamber 12.

The cooking chamber 12 is formed to be open at its front, wherein a cooking tray 12a in a form of a turntable is installed on the bottom of the cooking chamber 12 and a motor (not shown) is installed under the cooking tray 12a to rotate the cooking tray 12a. An inlet 15a which communicates with the machine room 11 to suck external air into the cooking chamber 12 is formed on a front portion of one sidewall 15 of the cooking chamber 12. An outlet 16a is formed on a back portion of the other sidewall 16 of the cooking chamber 12 to discharge air in the cooking chamber 12 to the outside.

The machine room 11 includes a magnetron 11a which oscillates microwaves, a cooling fan 11b which sucks external air to cool the machine room 11, and a guide duct 11c which guides air in the machine room 11 to the inlet 15a. The cooling fan 11b is disposed between the magnetron 11a and a back wall of the machine room 11. A plurality of suction holes 11d are formed in the back wall of the machine room 11 to suck the external air into the machine room 11.

The humidity sensor 17 is mounted on the other sidewall 16 of the cooking chamber 12 adjacent to the outlet 16a to be disposed in an air discharging path of the cooking chamber 12. Therefore, the humidity sensor 17 senses the humidity of the air being discharged from the cooking chamber 12 through the outlet 16a. The humidity sensor 17 is electrically connected to a control unit formed in the control panel 14, as will be described later.

FIG. 2 is a block diagram of the microwave oven shown in FIG. 1.

Referring to FIG. 2, the microwave oven further comprises a control unit 30 which controls the entire operations of the microwave oven. The control unit 30 is connected to an input unit 14a arranged in the control panel 14 and receives operation commands from a user. In addition, the control unit 30 is connected to the humidity sensor 17 which senses humidity, a weight sensor 12c installed under the cooking tray 12a which senses the weight of the food, and a temperature sensor 18 which detects a temperature of the food or the cooking chamber 12. A storage unit 20 is electrically connected to the control unit 30 and stores data. Furthermore, the control unit 30 is electrically connected to a magnetron driving unit 41 which drives the magnetron 11a, a fan driving unit 42 which drives the cooling fan 11b, a motor driving unit 43 which drives a motor 12b for rotating the cooking tray 12a, and a display driving unit 44 which drives a display unit 14b arranged in the control panel 14 to display information.

The storage unit 20 stores various factors preset according to the kind and the amount of food, and various data generated during a cooking operation.

The microwave oven of the present invention having the above construction cooks food by radiating the microwaves oscillated by the magnetron 11a to the cooking chamber 12. A user puts the food on the cooking tray 12a and manipulates the input unit 14a of the control panel 14 to operate the microwave oven.

An external air is sucked into the machine room 11 through the suction holes 11d to cool the machine room 11 using the cooling fan 11b during a cooking operation of the microwave oven. The external air is provided to the cooking chamber 12 through the guide duct 11c and the inlet 15a. Then, the air in the cooking chamber 12 is discharged to the outside through the outlet 16a, together with a water vapor generated from the food, as shown by arrows in FIG. 1. Accordingly, smell and the water vapor can be eliminated from the cooking chamber 12. In this case, the air in the cooking chamber 12 is discharged to the outside while being brought into contact with the humidity sensor 17. Accordingly, the humidity sensor 17 senses the water vapor contained in the discharged air and transmits sensing signals to the control unit 30.

The control unit 30 drives the magnetron 11a, the motor 12b and the cooling fan 11b to automatically cook the food based on the electrical signals (including output signals from the weight sensor 12c and the temperature sensor 18) received from the humidity sensor 17.

Hereinafter, a method of controlling an output power of the magnetron 11a of the microwave oven to cook rice in a bowl according to the present invention will be described.

FIGS. 3A and 3B are graphs illustrating an output power level as a function of time to describe the method of controlling the output power of the magnetron 11a to cook food.

At the start of a cooking operation, the microwave oven cooks food by maximizing the output power of the magnetron for a predetermined period of time. After the predetermined period of time elapses, the microwave oven cooks the food after decreasing the output power of the magnetron, until the water boils. At this time, a first cooking time T1 is set as an elapsed time prior to boiling of the water. A second cooking time T2 is calculated based on the first cooking time T1 and a preset condition. The second cooking time T2 denotes a period of time where the food is steam boiled. The

magnetron 11a operates at a preset output power required to steam boil the food for a determined period of time. After the second cooking time T2 elapses, the cooking is finished.

FIGS. 4 to 7 show flowcharts of the method of controlling the microwave oven to cook food according to the present invention. With reference to FIGS. 1-3A, the method of controlling the microwave oven will be described below.

A user puts food on the cooking tray 12a of the cooking chamber 12. Then, the user manipulates the functional buttons of the input unit 14a on the control panel 14 to set a cooking instruction, after the door 13 is shut, in operation 100.

Then, the control unit 30 determines whether a current set instruction is for cooking rice in a bowl, according to information input through the input unit 14a in operation 200. Where the current set instruction is for cooking rice in a bowl, the control unit 30 determines whether a cooking start instruction has been input through the input unit 14a in operation 300.

Where the cooking start instruction has been input in the operation 300, the control unit 30 performs an initializing operation in operation 400. In order to perform the initializing operation, the control unit 30 controls the fan driving unit 42 to operate the cooling fan 11b for an initialization time  $\Delta TR$ . In this case, the control unit 30 does not operate the magnetron 11a.

After the initializing operation for the initialization time  $\Delta TR$  in the operation 400, the control unit performs a first cooking operation in operation 500. After the first cooking operation, the control unit 30 sets the second cooking time T2 based on the time T1 required to perform the first cooking operation and a factor which is preset according to the kind of food and stored in the storage unit 20. Then, the control unit 30 performs the second cooking operation for the second cooking time T2 in operation 600. After the second cooking operation is completed, the control unit 30 controls the magnetron driving unit 41 to stop the operation of the magnetron 11a, and controls the fan driving unit 42 to stop the operation of the cooling fan 11b, thus completing the cooking operation in operation 700.

The initializing operation 400 of FIG. 4 is shown in FIG. 5 and is described in detail with reference to FIGS. 1-3A.

The control unit 30 determines whether a reference time has elapsed after power is supplied in operation 410. Where the reference time has elapsed, the control unit 30 executes a first initializing operation to drive only the cooling fan 11b for a preset first initializing time in operation 420. However, if the reference time did not elapse in the operation 410, the control unit 30 executes a second initializing operation to perform the initializing operation for a time which is longer than the first initializing time in operation 430.

The first cooking operation 500 of FIG. 4 is shown in FIG. 6 and is described in detail with reference to FIGS. 1-3A.

In order to perform the first cooking operation, the control unit 30 sets the output power of the magnetron 11a to a maximum output power in operation 510. Then, the control unit 30 controls the magnetron driving unit 41 to operate the magnetron 11a at the maximum output power.

The magnetron 11a radiates the microwaves to the cooking chamber 12, and the food irradiated by the microwaves is cooked by a frictional heat due to a rapid molecular motion of the water. As the cooling fan 11b is driven, the external air is sucked into the machine room 11 through the suction holes 11d, and is provided to the cooking chamber 12 through the guide duct 11c and the inlet 15a, while

5

cooling the magnetron **11a** and a high voltage transformer (not shown). Then, the air provided to the cooking chamber **12** is discharged to the outside through the outlet **16a** together with vapor generated during the cooking operation.

Referring back to FIG. 6, the control unit **30** determines whether the water has boiled through the humidity sensor **17** in operation **520**. Where the water does not boil at that point, the control unit **30** determines whether an instruction set at the setting operation **100** of FIG. 4 is for cooking of a soaked rice in operation **540**. Where the set instruction is for cooking of the soaked rice, the control unit **30** determines whether a preset first reference time A has elapsed in operation **540**. Where the preset first reference time A has elapsed in the operation **540**, the control unit **30** controls the magnetron driving unit **41** to decrease the output of the magnetron **11a** so as to prevent the water from overflowing in operation **550**.

On the other hand, if it is determined that the set instruction is not for cooking of the soaked rice in the operation **530**, the control unit **30** determines whether a preset second reference time B has elapsed in operation **530a**. Where the preset second reference time B has elapsed, the control unit **30** controls the magnetron driving unit **41** to decrease the output power of the magnetron **11a** so as to prevent the water from overflowing in the operation **550**.

After the operation **550**, the control unit **30** determines whether the water has boiled through the humidity sensor **17** in operation **560**. Where the water has boiled in the operation **560**, the control unit **30** sets an elapsed time before the water boils as the first cooking time **T1** in operation **570**. The control unit **30** sets the second cooking time **T2** based on the set first cooking time **T1** in operation **580**. That is, the control unit **30** sets the second cooking time **T2** by adding the first cooking time **T1** to a determined period of time, or by multiplying the first cooking time **T1** by the preset factor according to the kind of food being cooked.

On the other hand, where the water boils through the humidity sensor **17** in the operation **520**, the control unit **30** determines whether an elapsed time before the water boils exceeds a preset reference cooking time in operation **520a**. Where the elapsed time does not exceed the preset reference cooking time in the operation **520a**, the control unit **30** sets the second cooking time **T2** to a preset minimum time in operation **520b**, and returns to an initial operation of the second cooking operation **600** of FIG. 4. Where the elapsed time does exceed the preset reference cooking time in the operation **520a**, the control unit **30** controls to proceed to the operation **570**.

The second cooking operation **600** of FIG. 4 is shown in FIG. 7, and is described in detail with reference to FIGS. 1-3A.

The control unit **30** drives the magnetron **11a** at a preset output power for steam boiling the food in operation **610**. Then, the control unit **30** determines whether the second cooking time **T2** has elapsed in operation **620**. Where the second cooking time **T2** has elapsed in the operation **620**, the control unit **30** controls the magnetron driving unit **41** to stop the operation of the magnetron **11a** and controls the fan driving unit **42** to stop the operation of the cooling fan **11b**, thus completing the cooking operation in operation **630**, and returning to an initial operation of the complete cooking operation **700** of FIG. 4.

As described above, the present invention provides a method of controlling a microwave oven, which can prevent water from boiling off/to overflow by decreasing the output power of the microwave oven before the water boils while

6

cooking rice in a bowl. The present method allows rice, whether an amount for one person or for several people, to be evenly cooked throughout. That is, with the application of the present method, a single serving of rice in a container, submerged in water, can be steam boiled evenly as the cooking time and the output of the magnetron is controlled so as not to allow the water to boil to overflow off the container. It is understood that the present invention can be applied to cook a single or multiple servings of soup, coffee, and other food items with or without the container.

A system which uses the present invention also includes permanent or removable storage, such as magnetic and optical discs, RAM, ROM, etc., on which the process and data structures of the present invention can be stored and distributed. The operations can also be distributed via, for example, downloading over a network such as the Internet.

Although a few embodiments of the present invention have been shown and described, it will be appreciated by those skilled in the art that changes may be made in these embodiments without departing from the principles and spirit of the invention, the scope of which is defined in the appended claims and their equivalents.

What is claimed is:

1. A method of controlling a microwave oven having a cooking chamber for containing food therein, a cooling fan which circulates air, and a magnetron which generates microwaves, the method comprising:

setting a cooking instruction;

performing a first cooking for a first cook time while preventing water from boiling to overflow by controlling an output power of the magnetron according to the cooking instruction;

setting a second cook time according to the first cook time required to perform the first cooking; and

immediately after performing the first cooking, performing a second cooking for the second cook time while steam boiling the food, the output of the magnetron being at an output power level during the second cook time that is less than an output power level of the magnetron throughout the entire first cook time.

2. The method of claim 1, further comprising performing an initializing operation to operate only the cooling fan for an initialization time according to a power supply time prior to the first cooking.

3. The method of claim 1, wherein the performing of the second cooking comprises:

setting the output power of the magnetron to a preset output power for steam boiling of the food to cook the food;

determining whether the second cook time elapsed; and stopping operations of the magnetron and the cooling fan in response to an elapse of the second cook time.

4. A method of controlling a microwave oven having a cooking chamber for containing food therein, a cooling fan which circulates air, and a magnetron which generates microwaves, the method comprising:

setting a cooking instruction;

performing a first cooking for a first cook time while preventing water from boiling to overflow by controlling an output power of the magnetron according to the cooking instruction;

setting a second cook time according to the first cook time required to perform the first cooking;

performing a second cooking for the second cook time while steam boiling the food; and

7

performing an initializing operation to operate only the cooling fan for an initialization time according to a power supply time prior to the first cooking, wherein the performing of the initializing operation comprises: determining the power supply time,  
 performing a first initializing operation to operate only the cooling fan for a first initializing time in response to the power supply time being shorter than or equal to a reference time, and  
 performing a second initializing operation to operate only the cooling fan for a second initializing time in response to the power supply time being longer than the reference time, wherein the second initializing time is shorter than the first initializing time.

**5.** A method of controlling a microwave oven having a cooking chamber for containing food therein, a cooling fan which circulates air, a magnetron which generates microwaves and a humidity sensor which senses humidity of the cooking chamber, the method comprising:

setting a cooking instruction;  
 performing a first cooking for a first cook time while preventing water from boiling to overflow by controlling an output power of the magnetron according to the cooking instruction;  
 setting a second cook time according to the first cook time required to perform the first cooking; and  
 performing a second cooking for the second cook time while steam boiling the food, wherein the performing of the first cooking comprises:  
 operating the magnetron at a maximum output power, determining whether an operating time of the magnetron at the maximum output power exceeds a predetermined period of time,  
 controlling the output power of the magnetron to be lower than the maximum output power so as to prevent the water from boiling to overflow in response to the operating time exceeding the predetermined period of time,  
 sensing boiling of the water through the humidity sensor, and  
 determining the second cook time based on an elapsed time prior to the boiling of the water in response to the sensing of the boiling of the water by the humidity sensor.

**6.** The method of claim **5**, wherein the controlling of the output power to be lower comprises:

controlling the output power of the magnetron to be lower than the maximum output power in response to the operating time of the magnetron exceeding a first reference time and the setting of the cooking instruction being an instruction to cook rice soaked in the water, and  
 controlling the output power of the magnetron to be lower than the maximum output power in response to the operating time of the magnetron exceeding a second reference time, which is longer than the first reference time, and the setting of the cooking instruction being not for cooking of the rice soaked in the water.

**7.** The method of claim **5**, wherein the second cook time is a result of multiplying the first cook time required to perform the first cooking by a preset factor according to a kind of the food being cooked.

**8.** The method of claim **5**, wherein the second cook time is a result of adding the first cook time required to perform the first cooking to a determined period of time.

**9.** The method of claim **5**, wherein the determining of the second cook time comprises:

8

determining whether a preset reference time elapsed in response to the boiling of the water sensed through the humidity sensor after the operating of the magnetron at the maximum output power at the first cooking,

setting the second cook time as a preset minimum time in response to the preset reference time not being elapsed.

**10.** The method of claim **9**, wherein the setting of the second cook time is determined by one of the results of multiplying the first cook time required to perform the first cooking by a preset factor, and adding the first cook time required to perform the first cooking to a determined period of time, in response to an elapse of the preset reference time.

**11.** A computer readable medium encoded with operating instructions for implementing a method of controlling a microwave oven having a cooling fan, and a magnetron to cook food, performed by a computer, the method comprising:

setting a cooking instruction;  
 performing a first cooking for a first cook time while preventing water from boiling to overflow by controlling an output power of the magnetron according to the cooking instruction;  
 setting a second cook time according to the first cook time required to perform the first cooking; and  
 immediately after performing the first cooking, performing a second cooking for the second cook time while steam boiling the food, the output of the magnetron being at an output power level during the second cook time that is less than an output power level of the magnetron throughout the entire first cook time.

**12.** The computer readable medium of claim **11**, further comprising performing an initializing operation to operate only the cooling fan for an initialization time according to a power supply time prior to the first cooking.

**13.** The computer readable medium of claim **11**, wherein the performing of the second cooking comprises:

setting the output power of the magnetron to a preset output power for steam boiling of the food to cook the food;  
 determining whether the second cook time elapsed; and  
 stopping operations of the magnetron and the cooling fan in response to an elapse of the second cook time.

**14.** A computer readable medium encoded with operating instructions for implementing a method of controlling a microwave oven having a cooling fan, and a magnetron to cook food, performed by a computer, the method comprising:

setting a cooking instruction;  
 performing a first cooking for a first cook time while preventing water from boiling to overflow by controlling an output power of the magnetron according to the cooking instruction;  
 setting a second cook time according to the first cook time required to perform the first cooking;  
 performing a second cooking for the second cook time while steam boiling the food; and  
 performing an initializing operation to operate only the cooling fan for an initialization time according to a power supply time prior to the first cooking, wherein the performing of the initializing operation comprises:  
 determining the power supply time,  
 performing a first initializing operation to operate only the cooling fan for a first initializing time in response to the power supply time being shorter than or equal to a reference time, and

performing a second initializing operation to operate, only the cooling fan for a second initializing time in response to the power supply time being longer than the reference time, wherein the second initializing time is shorter than the first initializing time.

**15.** A computer readable medium encoded with operating instructions for implementing a method of controlling a microwave oven having a cooling fan, and a magnetron to cook food, performed by a computer, the method comprising:

setting a cooking instruction;

performing a first cooking for a first cook time while preventing water from boiling to overflow by controlling an output power of the magnetron according to the cooking instruction;

setting a second cook time according to the first cook time required to perform the first cooking; and

performing a second cooking for the second cook time while steam boiling the food, wherein the performing of the first cooking comprises:

operating the magnetron at a maximum output power, determining whether an operating time of the magnetron at the maximum output power exceeds a predetermined period of time,

controlling the output power of the magnetron to be lower than the maximum output power so as to prevent the water from boiling to overflow in response to the operating time exceeding the predetermined period of time,

sensing boiling of the water through the humidity sensor, and

determining the second cook time based on an elapsed time prior to the boiling of the water in response to the sensing of the boiling of the water by a humidity sensor which senses humidity of the cooking chamber.

**16.** The computer readable medium of claim **15**, wherein the controlling of the output power to be lower comprises:

controlling the output power of the magnetron to be lower than the maximum output power in response to the operating time of the magnetron exceeding a first reference time and the setting of the cooking instruction being an instruction to cook rice soaked in the water, and

controlling the output power of the magnetron to be lower than the maximum output power in response to the operating time of the magnetron exceeding a second reference time, which is longer than the first reference time, and the setting of the cooking instruction being not for cooking of the rice soaked in the water.

**17.** The computer readable medium of claim **15**, wherein the second cook time is a result of multiplying the first cook time required to perform the first cooking by a preset factor according to a kind of food being cooked.

**18.** The computer readable medium of claim **15**, wherein the second cook time is a result of adding the first cook time required to perform the first cooking to a determined period of time.

**19.** The computer readable medium of claim **15**, wherein the determining of the second cook time comprises:

determining whether a preset reference time elapsed in response to the boiling of the water sensed through the

humidity sensor after the operating of the magnetron at the maximum output power at the first cooking, and setting the second cook time as a preset minimum time in response to the preset reference time not being elapsed.

**20.** The computer readable medium of claim **19**, wherein the setting of the second cook time is determined by one of the results of multiplying the first cook time required to perform the first cooking by a preset factor, and adding the first cook time required to perform the first cooking to a determined period of time, in response to an elapse of the preset reference time.

**21.** A microwave oven comprising:

a cooking chamber for containing food therein;

a magnetron which generates microwaves to cook the food;

a humidity sensor which senses humidity in the cooking chamber; and

a controller which controls a cooking operation of the microwave oven, wherein the controller controls the microwave oven to perform a first cooking operation for a first cook time while preventing water from boiling to overflow by controlling an output power of the magnetron, and to perform a second cooking operation immediately after the first cooking operation to steam boil the food at a preset output power for a second cook time which is based on the first cook time and the humidity sensed by the humidity sensor, the output of the magnetron being at an output power level during the second cook time that is less than an output power level of the magnetron throughout the entire first cook time.

**22.** A method of controlling a microwave oven having a cooking chamber for containing food therein, a cooling fan which circulates air, a magnetron which generates microwaves and a humidity sensor which senses humidity of the cooking chamber, the method comprising:

setting a cooking instruction;

performing a first cooking for a first cook time comprises: operating the magnetron at a maximum output power for a predetermined period of time according to the cooking instruction, and

lowering an output power of the magnetron to a first output power so as to prevent water from boiling to overflow in response to an elapse of the predetermined time;

determining the first cook time in response to sensing boiling of the water through the humidity sensor, and performing a second cooking comprises:

lowering the output power of the magnetron to a second output power to steam boil the water, and

operating the magnetron at the second output power for a second cook time, wherein the second cook time is based the first cook time.

**23.** The method of claim **22**, wherein the determining of the first cook time comprises setting the first cook time as an elapsed time prior to the boiling of the water sensed by the humidity sensor.

**24.** The method of claim **23**, wherein the second output power is lower than the first output power.

UNITED STATES PATENT AND TRADEMARK OFFICE  
**CERTIFICATE OF CORRECTION**

PATENT NO. : 6,875,968 B2  
DATED : April 5, 2005  
INVENTOR(S) : Lee et al.

Page 1 of 1

It is certified that error appears in the above-identified patent and that said Letters Patent is hereby corrected as shown below:

Column 9,  
Line 1, delete “,” after “operate”.

Signed and Sealed this

Twenty-second Day of November, 2005

A handwritten signature in black ink on a light gray dotted background. The signature reads "Jon W. Dudas" in a cursive style.

JON W. DUDAS  
*Director of the United States Patent and Trademark Office*