



US006860544B2

(12) **United States Patent**
Malott

(10) **Patent No.:** **US 6,860,544 B2**
(45) **Date of Patent:** **Mar. 1, 2005**

(54) **RECREATIONAL VEHICLE SLIDE-OUT
AWNING WITH INTERMEDIATE SUPPORT**

(75) Inventor: **Dale G. Malott**, Middlebury, IN (US)

(73) Assignee: **Dometic Corporation**, Elkhart, IN (US)

(*) Notice: Subject to any disclaimer, the term of this patent is extended or adjusted under 35 U.S.C. 154(b) by 0 days.

(21) Appl. No.: **10/838,020**

(22) Filed: **May 3, 2004**

(65) **Prior Publication Data**

US 2004/0201248 A1 Oct. 14, 2004

Related U.S. Application Data

(62) Division of application No. 10/287,128, filed on Nov. 4, 2002, now Pat. No. 6,729,679.

(51) **Int. Cl.**⁷ **B60R 15/00**

(52) **U.S. Cl.** **296/175**; 296/171; 242/595.1; 135/88.1; 160/68; 160/67

(58) **Field of Search** 296/175, 163, 296/171, 26.13, 136; 160/67, 71, 22, 66, 70, 80, 79; 135/88.12, 88.1, 903, 88.11, 90; 52/67, 79.5

(56) **References Cited**

U.S. PATENT DOCUMENTS

827,483 A	7/1906	Voorhees	
1,377,784 A	5/1921	Nodland	242/595.1
2,220,311 A	11/1940	Anton	242/595.1
2,326,642 A	8/1943	Heiser	242/595.1
2,890,853 A	6/1959	D'Azzo	248/273
2,948,288 A	8/1960	Nelson	135/88.1
3,722,571 A	3/1973	Knight et al.	160/68
3,834,400 A	9/1974	Sattler	135/88.12
3,851,848 A	12/1974	Wiele	

3,918,511 A	11/1975	Upton	160/67
3,980,121 A	9/1976	McKee	160/71
4,077,419 A	3/1978	Lux	160/68
4,117,876 A	10/1978	Bennett	
4,188,964 A	2/1980	Greer	160/67
4,211,374 A	7/1980	Salvino	242/595.1
4,269,531 A	5/1981	Brolin	160/22
4,634,172 A	1/1987	Duda	
4,640,332 A	2/1987	Turner	160/71
4,727,897 A	3/1988	Watts	135/88.1
4,801,119 A	1/1989	Pelletier	135/88.12
5,044,416 A	9/1991	Murray	
5,171,056 A	12/1992	Faludy et al.	296/175
5,174,352 A	12/1992	Murray et al.	
5,280,687 A	1/1994	Boiteau	296/171
5,285,837 A	2/1994	Pozzi	160/66
5,365,989 A	11/1994	Eger et al.	160/70
5,423,506 A	6/1995	Spoon	
5,558,145 A	9/1996	Baka	160/67
5,560,412 A	10/1996	Murray	160/67
5,601,267 A	2/1997	Caine	160/67
5,636,675 A	6/1997	Baka et al.	160/67
5,752,536 A	5/1998	Becker	296/171
5,819,830 A	10/1998	Verelst	160/66
5,860,440 A	1/1999	Murray et al.	296/175
5,944,085 A	8/1999	Malott	160/57
6,123,136 A	9/2000	Williams	160/67
RE37,567 E	3/2002	Murray	296/175
2002/0092552 A1	7/2002	Jones	135/88.01

Primary Examiner—Kiran Patel

(74) *Attorney, Agent, or Firm*—Pearne & Gordon LLP

(57) **ABSTRACT**

An intermediate support for a retractable roll awning. The support is positioned between two end brackets and provides additional support. The support includes a two support surfaces for supporting the roll awning in two directions. Alternatively, the support may comprise a single curved support surface. The support surface or surfaces include an arrangement for reducing friction.

4 Claims, 5 Drawing Sheets

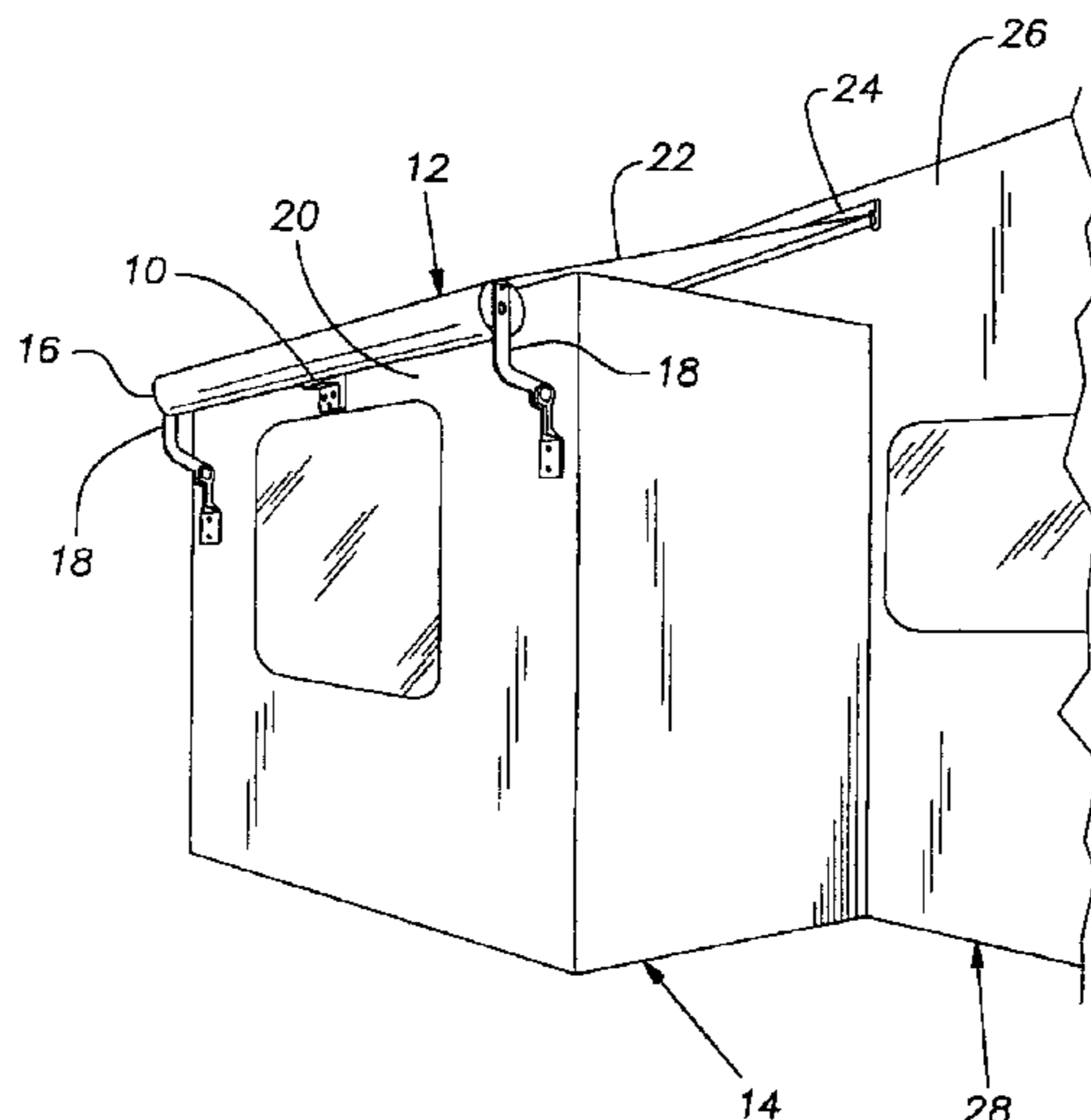

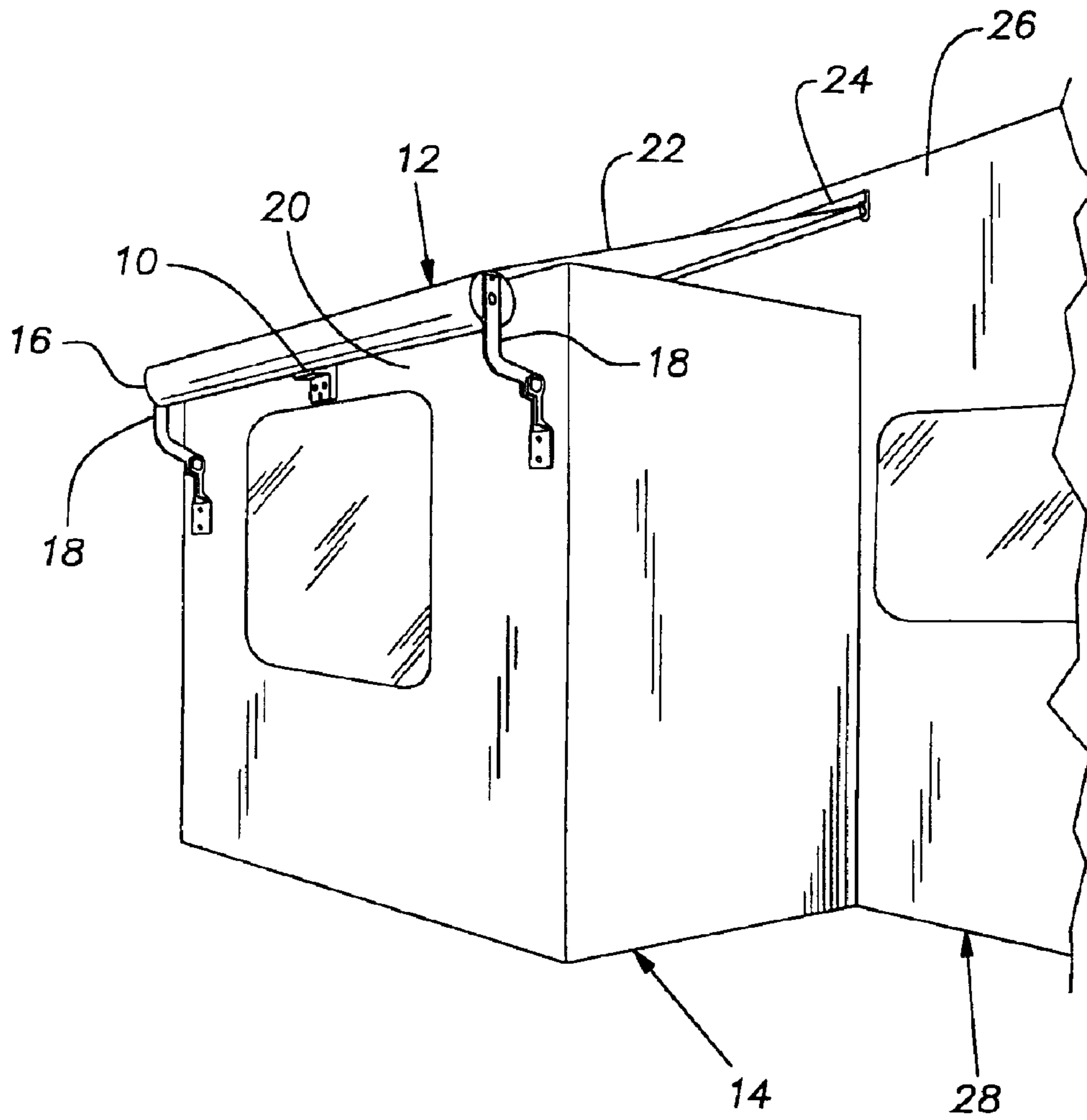

FIG. 1

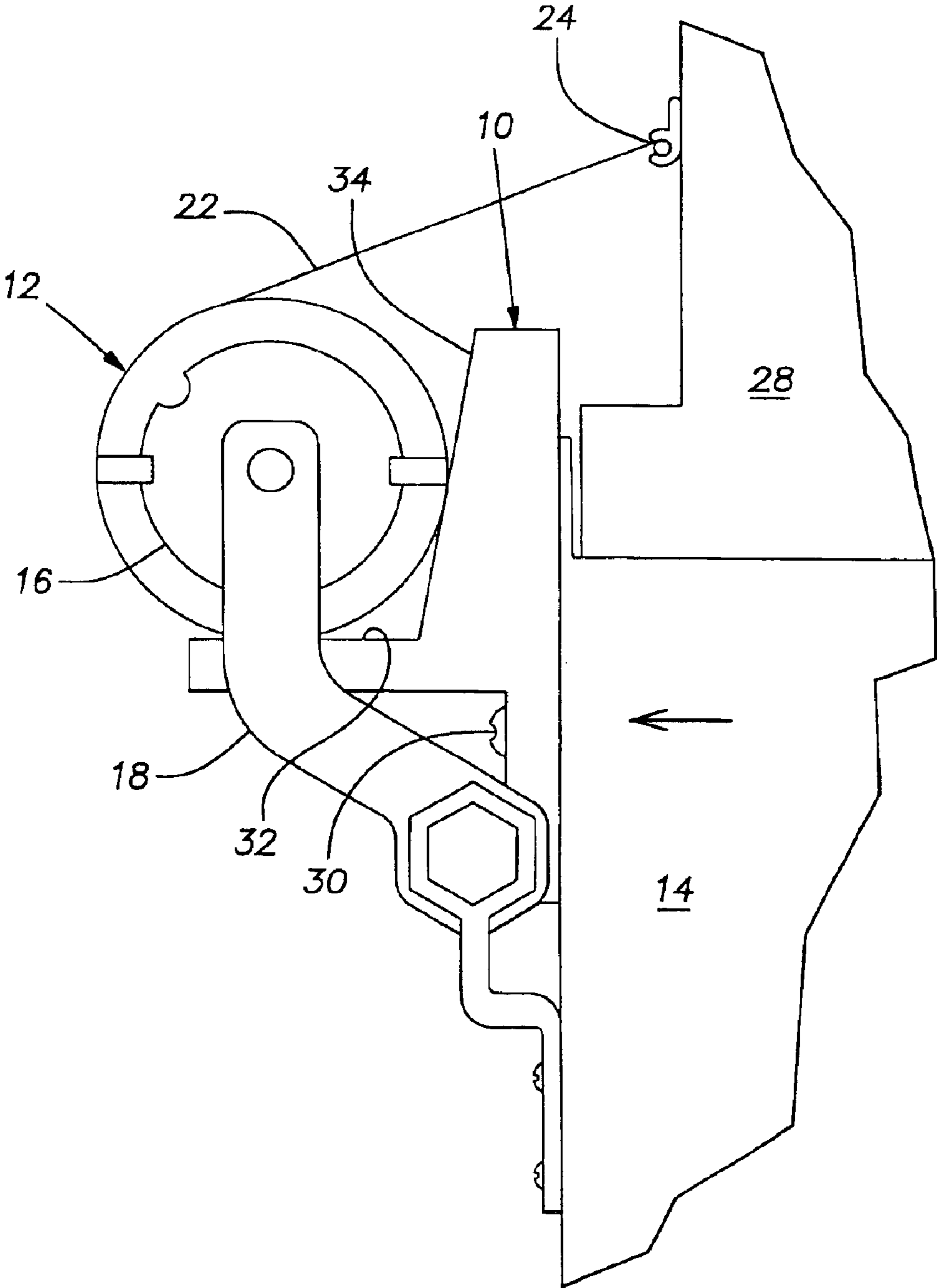

FIG. 2

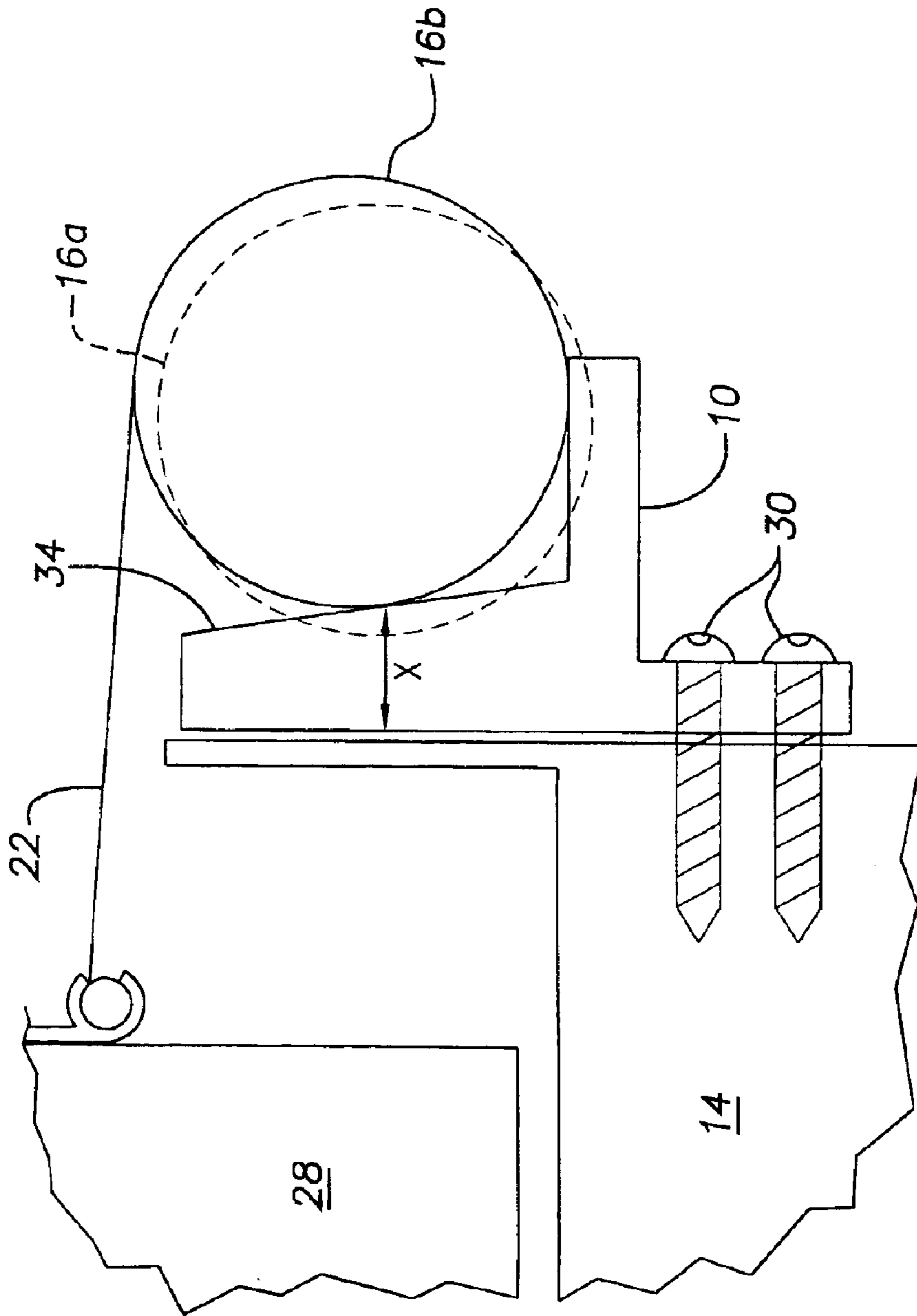

FIG. 3

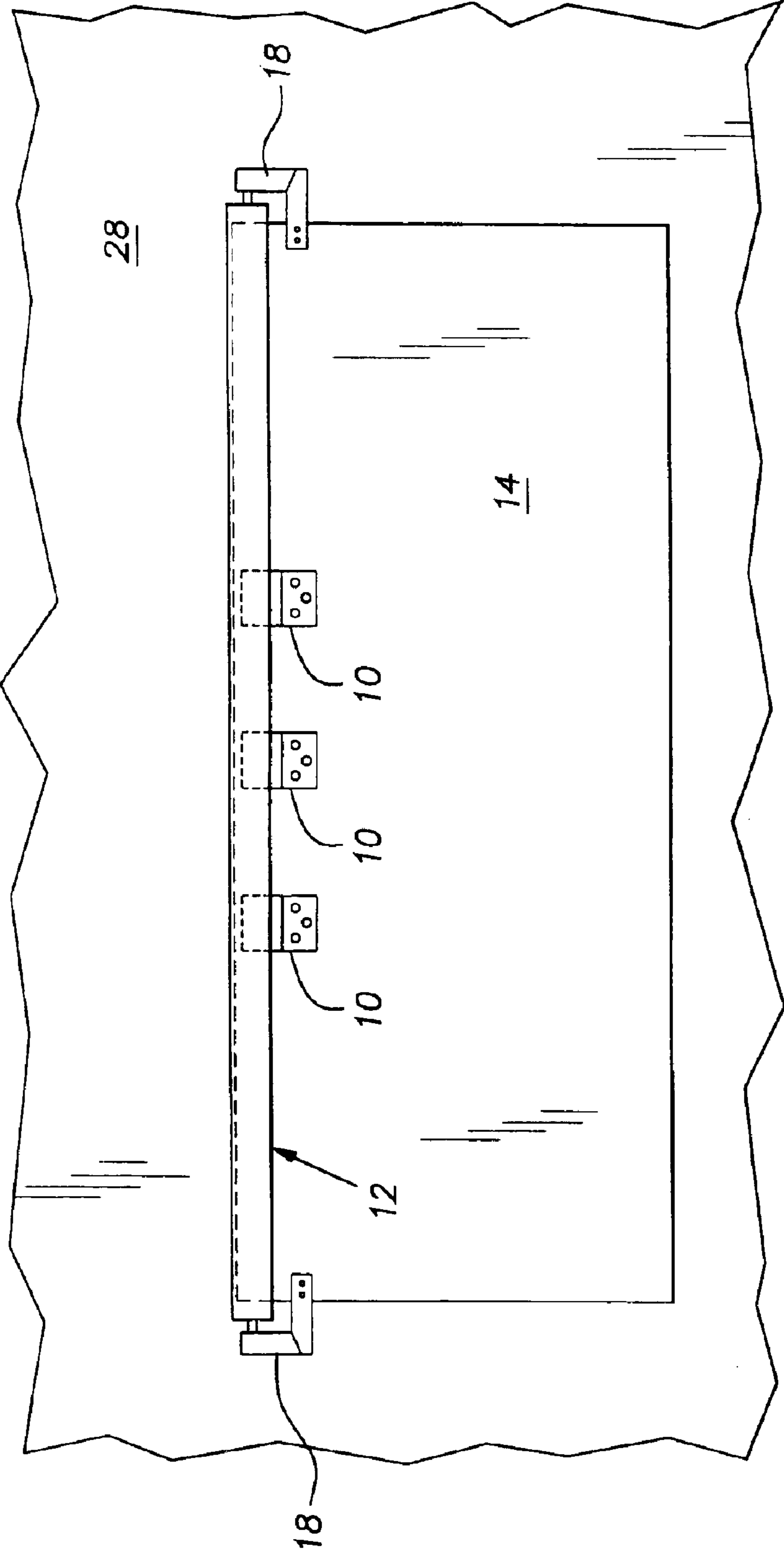

FIG. 4

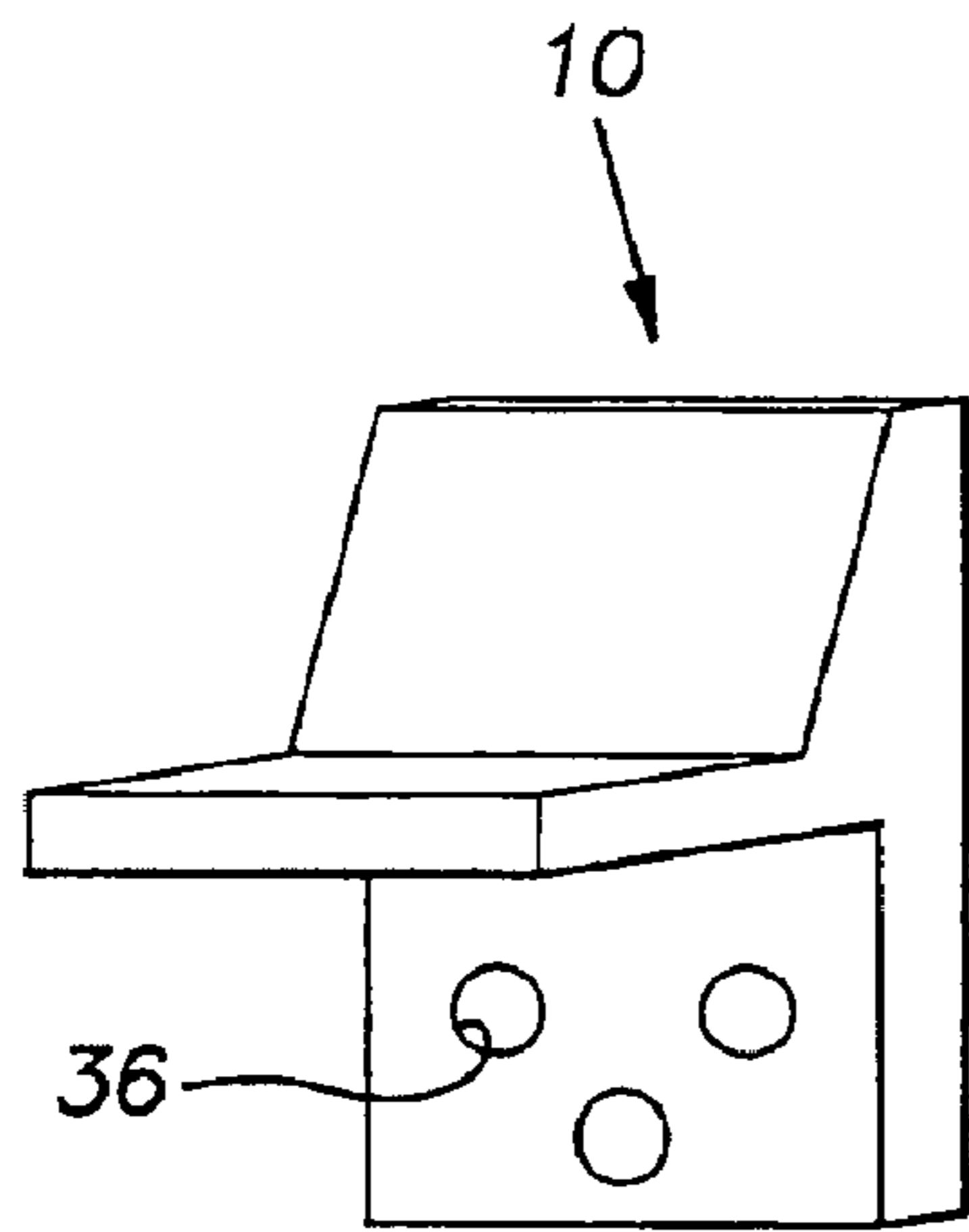

FIG. 5

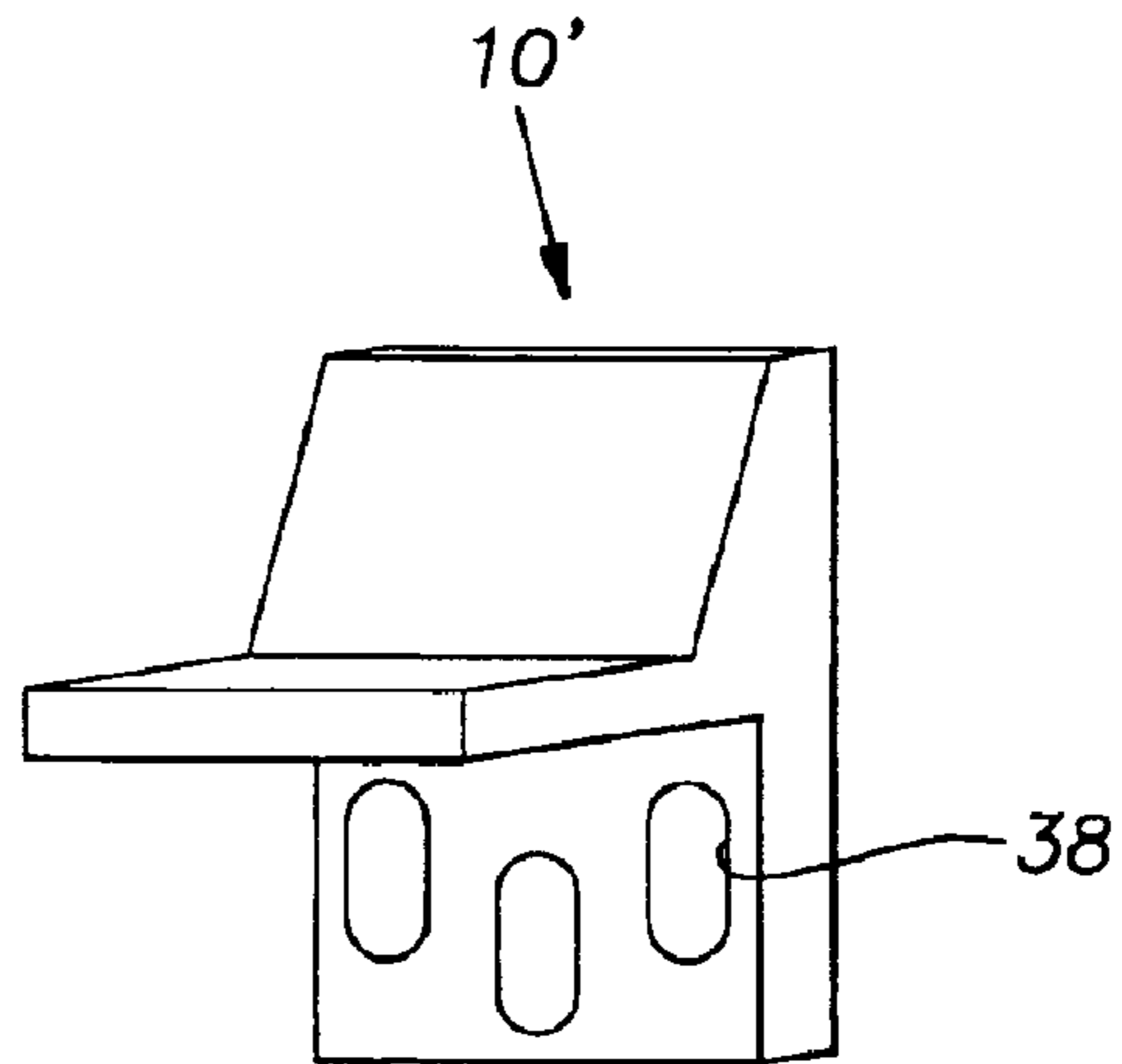

FIG. 6

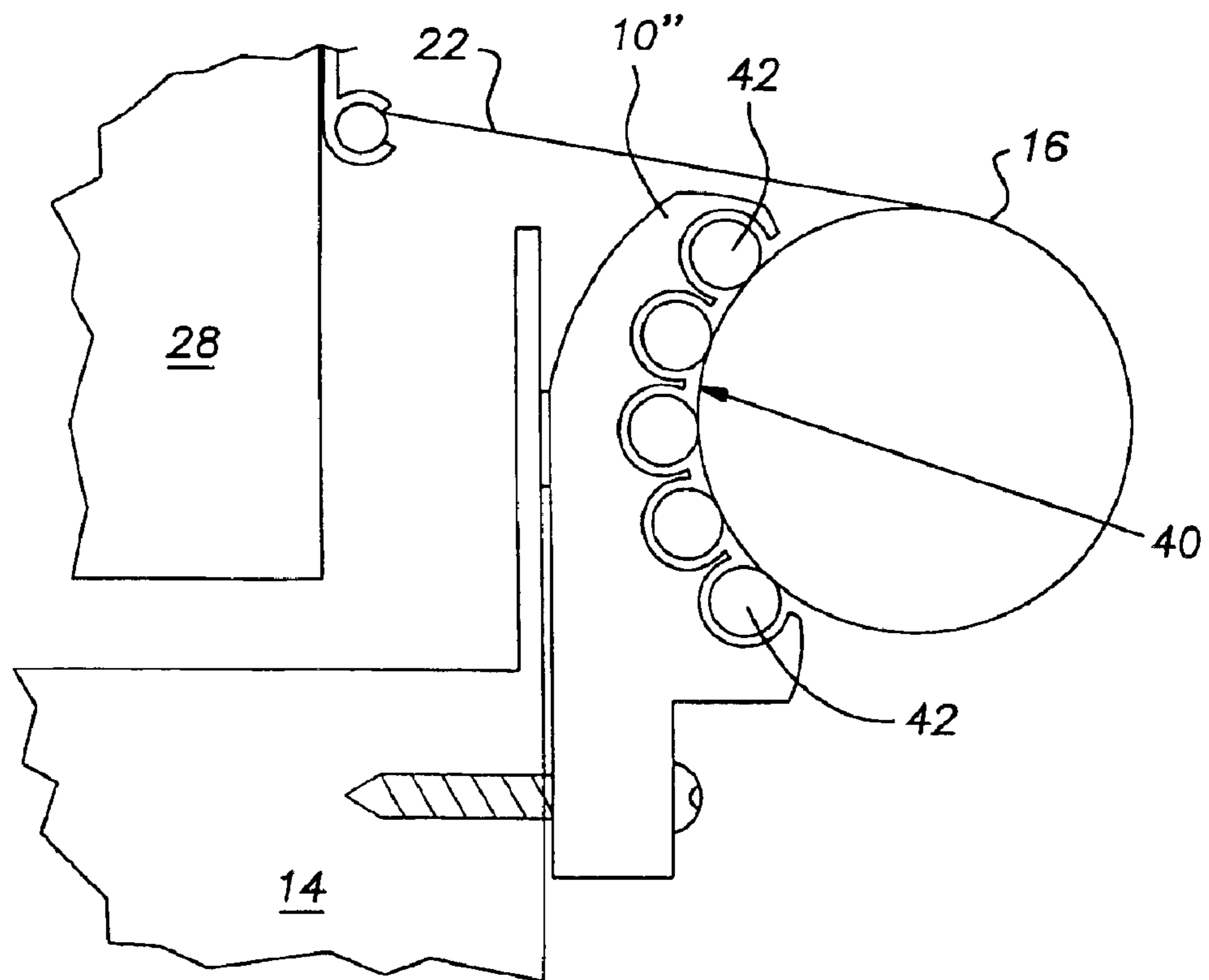

FIG. 7

1

RECREATIONAL VEHICLE SLIDE-OUT AWNING WITH INTERMEDIATE SUPPORT

BACKGROUND OF THE INVENTION

This invention relates generally to retractable awnings, and more particularly, to an intermediate support for a retractable awning for use with recreation vehicles having retractable slide-out portions.

Typical vehicles which must be transported over the roads, such as travel trailers and motor homes, are restricted in width to about eight feet. Any vehicle having a greater width usually requires a wide load permit. This width limitation severely limits the interior lay-out of the vehicle. Therefore, some recreational vehicles have been provided with retractable structures generally referred to as a "slide-outs" or slide-out rooms have been provided in many recreational vehicles. Such slide-outs are generally rectangular, and in some instances, extend lengthwise of the vehicle for substantial distance. Further, because of their size, such slide-outs are generally moved between the retracted and extended position by powered actuators. An example of a slide-out is illustrated in the U.S. Pat. No. 4,500,132.

It is customary to form the roof of the slide-out as a flat surface extending parallel to the roof of the vehicle. Such slide-out roofs, which are flat and extend horizontally, tend to collect leaves, snow, dirt and other debris. Although seals have been provided for slide-outs to resist the movement of such debris into the vehicle interior when the slide-out is retracted, difficulty is often encountered because such debris is carried past the seal and enters the interior of the vehicle when the slide-out is retracted for road travel.

In order to prevent the collection of debris on the roof of a slide-out, a retractable awning system has been provided in which a retractable awning was mounted so as to cover a substantial portion of the roof of the slide-out when the slide-out was extended. The intention of such awning was to cause any rain, snow, leaves or other debris to collect on the surface of the awning, and not on the roof, per se. The awning is structured so that as the slide-out is retracted, the awning rolls up on a roll journaled at the outer surface of the slide-out and drops the debris harmlessly on the ground. The roll is supported and journaled by a pair of brackets located at either end of the roll. Such a retractable awning is illustrated and described in the U.S. Pat. No. 5,280,687.

For especially long rolls, since they are only supported at their ends, the middle section of the roll may tend to sag or bow. The disadvantage of such sagging is an untidy appearance, as well as diminished shedding of water and debris.

SUMMARY OF THE INVENTION

The present invention provides a recreational vehicle comprising a side wall, a slide-out room extendable from the side wall of the vehicle, a roll awning journaled to the slide-out room by a pair of brackets at ends of the roll awning, the roll awning comprising a fabric having one edge secured to the side wall. The recreational vehicle further comprises an intermediate support attached to the slide-out room and comprising a supporting surface that supports the roll awning at a location between the pair of brackets as the slide-out room is being extended from the side wall.

BRIEF DESCRIPTION OF SEVERAL VIEWS OF THE DRAWING

FIG. 1 is a perspective view showing an intermediate support for a slide-out room of a vehicle according to the present invention;

2

FIG. 2 is a side view of the support of FIG. 1;

FIG. 3 is a schematic sectional view of an intermediate support according to the present invention;

FIG. 4 is a front elevation showing supports according to an alternative embodiment of the invention;

FIG. 5 is a perspective view showing the intermediate support of FIG. 1;

FIG. 6 is a perspective view showing an intermediate support for a slide-out room of a vehicle according to a first alternate embodiment of the present invention; and

FIG. 7 is a side view showing an intermediate support for a slide-out room of a vehicle according to a second alternate embodiment of the present invention.

DETAILED DESCRIPTION OF THE INVENTION

Referring to FIGS. 1-3, the present invention provides an intermediate support **10** for a slide-out awning or cover assembly **12** used for a vehicle slide-out room **14**. The awning assembly **12** comprises an awning roll **16** journaled to a pair of brackets **18** acting as end supports that are attached a wall **20** of the slide-out room **14**. An awning **22** comprising a sheet of fabric is wound around the roll **16** and secured at one edge **24** to a stationary wall **26** of the vehicle **28**. As the slide-out **14** is extended from the wall **26** of a vehicle **28**, the rolled awning **22** unwinds while the edge **24** of the awning **22** remains secured to the stationary vehicle wall **26**.

The support **10** of the present invention attaches to the wall **20** of the slide-out room **14** and supports the awning assembly **12** at a location intermediate to the brackets **18**. The support **10** is secured to the wall **20** by one or more screws **30**.

As best shown in FIGS. 2 and 3, the support **10** is generally L-shaped having a relatively flat bottom surface **32** and a sloped back or rear surface **34**, both of which contact the awning assembly **12** proximate to its midpoint as it unrolls or rolls up on the support **10**. The support **10** prevents bowing or sagging of the roll **16**. One or more of the support surfaces **32**, **34** may have a friction-reducing coating, such as polytetrafluoroethylene (PTFE), to facilitate rolling up or unwinding of the awning **22**. Alternatively, the support **10** itself may be made from a low friction material.

As shown in FIG. 3, the support **10** both lifts the roll **16** and spaces it from the wall **20**. The position of the middle of the roll **16** is schematically shown in broken lines **16a** as sagging without the support **10** and in solid lines **16b** as supported. The distance, x , from the wall **20** is set to hold the roll **16** straight or slightly bowed away from the wall **20** at the midpoint of its length. The height of the support **10** is set so the roll **16** is straight or slightly bowed up at the midpoint of its length. Since the roll **16** decreases in diameter as the awning **22** is unwound, the bowed support prevents the roll **16** from sagging due to this decrease in diameter.

Alternatively, as shown in FIG. 4, multiple supports **10** can be used, spaced apart along the length of the roll **16**. The number of supports **10** required to adequately support a particular roll depends upon the roll's length and girth.

As best shown in FIG. 5, three holes **36** are provided on the support **10** to accommodate the screws **30** for securing the support **10** to the wall **20**. As a first alternative embodiment, shown in FIG. 6, elongated holes **38** can be provided to allow for vertical adjustment of the support **10**. Further, it should be appreciated that any number of holes can be provided. Further, other means of fastening the

3

support **10**, **10'** to the wall **20** can be used, such as riveting, welding or gluing.

As a second alternative embodiment, shown in FIG. 7, a curved support **10''** has a single curved support surface **40**, as a substitute for the two support surfaces **32**, **34** of the support **10**, **10'** of FIGS. 1-6. The shape of the surface **40** provides the horizontal and vertical support of the previous embodiment and additionally provides support in the negative vertical direction to prevent the awning roll **16** from being lifted under the tension of being deployed. Further, roller or ball bearings **42**, as schematically shown, are provided to reduce the friction between the roll **16** and the surface **40**. Although five bearings **42** are shown, any number of rollers can be used according to the present invention. Further, the bearings **42** could be replaced by other means of reducing friction, such as balls bearings or a low friction surface such as PTFE, as in the previous embodiments. Moreover, it should be appreciated that the bearings **42** of the embodiment of FIG. 7 could be adapted for use in the embodiments of FIGS. 1-6.

It should be evident that this disclosure is by way of example and that various changes maybe made by adding, modifying or eliminating details without departing from the fair scope of the teaching contained in this disclosure. The invention is therefore not limited to particular details of this disclosure except to the extent that the following claims are necessarily so limited.

4

What is claimed is:

1. A recreational vehicle comprising:

a side wall;

a slide-out room extendable from the side wall of the vehicle;

a roll awning journaled to the slide-out room by a pair of brackets at ends of the roll awning, the roll awning comprising a fabric having one edge secured to the side wall; and

an intermediate support attached to the slide-out room and comprising a supporting surface that supports the roll awning at a location between the pair of brackets as the slide-out room is being extended from the side wall;

wherein the supporting surface comprises a friction-reducing arrangement;

wherein the friction-reducing arrangement comprises a bearing.

2. The recreational vehicle of claim 1, wherein the bearing comprises a roller bearing.

3. The recreational vehicle of claim 1, wherein the bearing comprises a ball bearing.

4. The recreational vehicle of claim 1, wherein the friction-reducing arrangement comprises a plurality of bearings.

* * * * *