



US006857697B2

(12) **United States Patent**  
**Brennan et al.**

(10) **Patent No.:** **US 6,857,697 B2**  
(45) **Date of Patent:** **Feb. 22, 2005**

(54) **AUTOMOTIVE VEHICLE SEATING COMFORT SYSTEM**

(75) Inventors: **Lindy Brennan**, Kingsville (CA);  
**Goran Bajic**, Windsor (CA); **Lucas Fernandez**, Windsor (CA); **Valerija Drobnajakovic**, LaSalle (CA)

(73) Assignee: **W.E.T. Automotive Systems AG**,  
Odelzhausen (DE)

(\*) Notice: Subject to any disclaimer, the term of this patent is extended or adjusted under 35 U.S.C. 154(b) by 94 days.

(21) Appl. No.: **10/463,052**

(22) Filed: **Jun. 17, 2003**

(65) **Prior Publication Data**

US 2003/0214160 A1 Nov. 20, 2003

**Related U.S. Application Data**

(60) Provisional application No. 60/407,198, filed on Aug. 29, 2002, and provisional application No. 60/428,003, filed on Nov. 21, 2002.

(51) **Int. Cl.**<sup>7</sup> ..... **A47C 31/00**

(52) **U.S. Cl.** ..... **297/180.13; 297/180.12**

(58) **Field of Search** ..... 297/180.1, 180.11, 297/180.12, 180.13, 180.14

(56) **References Cited**

**U.S. PATENT DOCUMENTS**

374,424 A	12/1887	Ober
390,154 A	9/1888	Beach
1,370,832 A	3/1921	Mollberg
1,439,681 A	12/1922	Alkire et al.
1,475,912 A	11/1923	Williams
1,514,329 A	11/1924	Metcalf
1,537,460 A	5/1925	Campbell et al.

1,541,213 A	6/1925	Harley
1,593,066 A	7/1926	Gaston
1,664,636 A	4/1928	Mayer
1,837,515 A	12/1931	Bachrach
1,936,960 A	11/1933	Bowman
2,022,959 A	12/1935	Gordon
2,103,553 A	12/1937	Reynolds
2,158,801 A	5/1939	Petterson
2,336,089 A	12/1943	Gould

(List continued on next page.)

**FOREIGN PATENT DOCUMENTS**

DE	3513909 A1 *	10/1986	.....	B60N/1/00
DE	37 05 756 A1	10/1988		
DE	197 36 951 A1	3/1999		

(List continued on next page.)

**OTHER PUBLICATIONS**

Automotive Seat Heating Systems, Bauerhin International, received by Assignee W.E.T. Automotive Systems on or about May 2002.

(List continued on next page.)

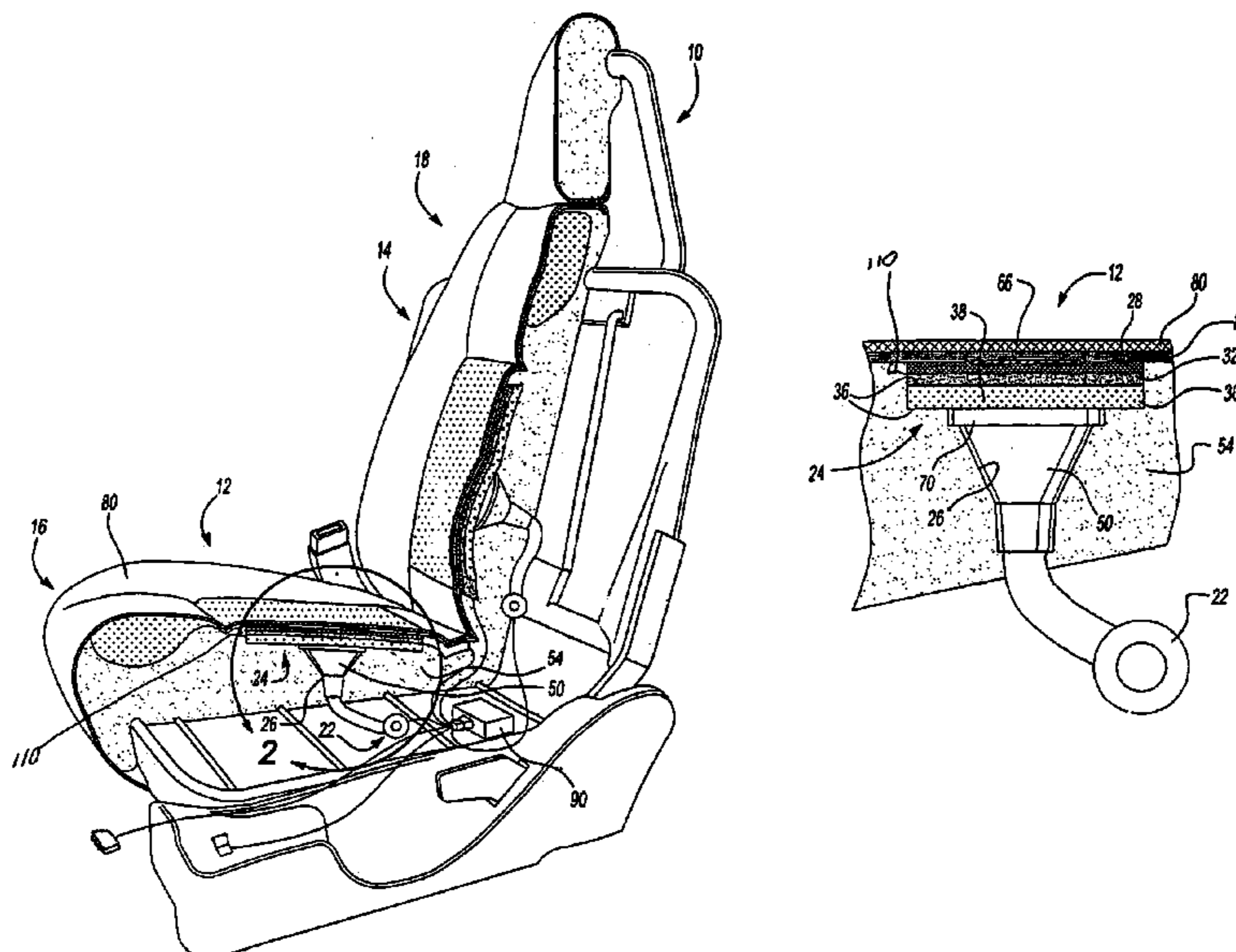
*Primary Examiner*—Peter M. Cuomo  
*Assistant Examiner*—Stephanie Harris

(74) *Attorney, Agent, or Firm*—Dobrusin & Thennisch, PC

(57) **ABSTRACT**

There is disclosed an automotive vehicle seating comfort system for providing heating, cooling, ventilation or a combination thereof to an individual in an automotive car seat. The system typically includes an insert, a blower and a tubular structure for providing fluid communication between the insert and blower for providing ventilation and/or cooling for the individual. Preferably, the insert includes a heater or heater layer for providing heat for the individual.

**18 Claims, 2 Drawing Sheets**



U.S. PATENT DOCUMENTS

2,493,303 A	1/1950	McCullough	5,016,302 A	5/1991	Yu
2,544,506 A	3/1951	Kronhaus	5,102,189 A	4/1992	Saito et al.
2,703,134 A	3/1955	Mossor	5,106,161 A	4/1992	Meiller
2,749,906 A	6/1956	O'Connor	5,117,638 A	6/1992	Feher
2,758,532 A	8/1956	Awe	5,160,517 A	11/1992	Hicks et al.
2,782,834 A	2/1957	Vigo	5,211,697 A	5/1993	Kienlein et al.
2,791,956 A	5/1957	Guest	5,226,188 A	7/1993	Liou
2,826,135 A	3/1958	Benzick	5,292,577 A	3/1994	Van Kerrebrouck et al.
2,912,832 A	11/1959	Clark	5,335,381 A	8/1994	Chang
2,931,286 A	4/1960	Fry, Sr. et al.	5,354,117 A	10/1994	Danielson et al.
2,976,700 A	3/1961	Jackson	5,356,205 A	10/1994	Calvert et al.
2,978,972 A	4/1961	Hake	5,370,439 A	* 12/1994	Lowe et al. .... 297/180.11
2,992,604 A	7/1961	Trotman et al.	5,372,402 A	12/1994	Kuo
2,992,605 A	7/1961	Trotman et al.	5,382,075 A	1/1995	Shih
3,030,145 A	4/1962	Kottermann	5,385,382 A	1/1995	Single, II et al.
3,101,037 A	8/1963	Taylor	5,403,065 A	4/1995	Callerio
3,101,660 A	8/1963	Taylor	5,408,711 A	4/1995	McClelland
3,127,931 A	4/1964	Johnson	5,411,318 A	5/1995	Law
3,131,967 A	5/1964	Spaulding	5,416,935 A	5/1995	Nieh
3,136,577 A	* 6/1964	Richard ..... 297/180.11	5,524,439 A	6/1996	Gallup et al.
3,137,523 A	6/1964	Karner	5,561,875 A	10/1996	Graebe
3,162,489 A	12/1964	Trotman	5,590,428 A	1/1997	Roter
3,209,380 A	10/1965	Watsky	5,597,200 A	1/1997	Gregory et al.
3,486,177 A	12/1969	Marshack	5,613,729 A	3/1997	Summer, Jr.
3,529,310 A	9/1970	Olmo	5,613,730 A	3/1997	Buie et al.
3,550,523 A	12/1970	Segal	5,626,021 A	5/1997	Karunasiri et al.
3,552,133 A	1/1971	Lukomsky	5,626,386 A	5/1997	Lush
3,628,829 A	12/1971	Hellig	5,626,387 A	5/1997	Yeh
3,653,589 A	4/1972	McGrath	5,645,314 A	7/1997	Liou
3,653,590 A	4/1972	Elsea	5,692,952 A	12/1997	Chih-Hung
3,681,797 A	8/1972	Messner	5,715,695 A	2/1998	Lord
3,684,170 A	8/1972	Roof	5,787,534 A	8/1998	Hargest et al.
3,732,944 A	5/1973	Kendall	5,833,309 A	11/1998	Schmitz
3,736,022 A	5/1973	Radke	5,833,321 A	11/1998	Kim et al.
3,738,702 A	6/1973	Jacobs	5,902,014 A	* 5/1999	Dinkel et al. .... 297/452.43
3,757,366 A	9/1973	Sacher	5,918,930 A	7/1999	Kawai et al.
3,778,851 A	12/1973	Howorth	5,921,314 A	7/1999	Schuller et al.
3,948,246 A	4/1976	Jenkins	5,921,858 A	7/1999	Kawai et al.
4,002,108 A	1/1977	Drori	5,924,766 A	* 7/1999	Esaki et al. .... 297/180.13
4,043,544 A	8/1977	Ismer	5,924,767 A	7/1999	Pietryga
4,060,276 A	11/1977	Lindsay	5,927,817 A	7/1999	Ekman et al.
4,065,936 A	1/1978	Fenton et al.	5,934,748 A	* 8/1999	Faust et al. .... 297/180.12
4,072,344 A	2/1978	Li	6,003,950 A	* 12/1999	Larsson ..... 297/452.42
4,141,585 A	2/1979	Blackman	6,019,420 A	2/2000	Faust et al.
4,175,297 A	11/1979	Robbins et al.	6,048,024 A	4/2000	Wallman
4,259,896 A	4/1981	Hayashi et al.	6,059,018 A	* 5/2000	Yoshinori et al. .... 165/42
4,379,352 A	4/1983	Hauslein et al.	6,062,641 A	5/2000	Suzuki et al.
4,391,009 A	7/1983	Schild et al.	6,064,037 A	* 5/2000	Weiss et al. .... 219/217
4,413,857 A	11/1983	Hayashi	6,068,332 A	* 5/2000	Faust et al. .... 297/180.13
4,509,792 A	4/1985	Wang	6,079,485 A	* 6/2000	Esaki et al. .... 165/43
4,563,387 A	1/1986	Takagi et al.	6,105,667 A	8/2000	Yoshinori et al.
4,572,430 A	2/1986	Takagi et al.	6,124,577 A	9/2000	Fristedt
4,589,656 A	5/1986	Baldwin	6,147,332 A	11/2000	Holmberg et al.
4,665,707 A	5/1987	Hamilton	6,164,719 A	* 12/2000	Rauh ..... 297/180.12
4,671,567 A	6/1987	Frobese	6,179,706 B1	* 1/2001	Yoshinori et al. .... 454/120
4,685,727 A	8/1987	Cremer et al.	6,186,592 B1	* 2/2001	Orizaris et al. .... 297/180.12
4,712,832 A	12/1987	Antolini et al.	6,189,966 B1	2/2001	Faust et al.
4,729,598 A	3/1988	Hess	6,224,150 B1	* 5/2001	Eksin et al. .... 297/180.1
4,777,802 A	10/1988	Feher	6,278,090 B1	8/2001	Fristedt et al.
4,847,933 A	7/1989	Bedford	6,291,803 B1	9/2001	Fourrey
4,853,992 A	8/1989	Yu	6,300,150 B1	10/2001	Venkatasubramanian
4,866,800 A	9/1989	Bedford	6,481,801 B1	11/2002	Schmale
4,905,475 A	3/1990	Tuomi	6,505,886 B2	1/2003	Gielda et al.
4,923,248 A	5/1990	Feher	6,511,125 B1	* 1/2003	Gendron ..... 297/180.11
4,946,220 A	8/1990	Wyon et al.	6,539,725 B2	4/2003	Bell
4,964,674 A	* 10/1990	Altmann et al. .... 297/180.12	6,541,737 B1	* 4/2003	Eksin et al. .... 219/217
4,981,324 A	1/1991	Law	RE38,128 E	6/2003	Gallup et al.
4,997,230 A	3/1991	Spitalnick	6,598,405 B2	7/2003	Bell
5,002,336 A	3/1991	Feher	6,619,736 B2	* 9/2003	Stowe et al. .... 297/180.14
5,004,294 A	4/1991	Lin	6,625,990 B2	9/2003	Bell
			6,629,724 B2	* 10/2003	Ekern et al. .... 297/180.11

2001/0035669	A1	11/2001	Andersson et al.	
2002/0017102	A1	2/2002	Bell	
2002/0067058	A1 *	6/2002	Pfahler .....	297/180.11
2002/0092308	A1	7/2002	Bell	
2002/0096915	A1	7/2002	Haupt et al.	
2002/0096931	A1 *	7/2002	White et al. ....	297/452.42
2002/0105213	A1	8/2002	Rauh et al.	
2002/0108381	A1	8/2002	Bell	
2002/0139123	A1	10/2002	Bell	
2002/0140258	A1	10/2002	Ekern et al.	
2002/0148234	A1	10/2002	Bell	
2002/0148235	A1	10/2002	Bell	
2002/0148236	A1	10/2002	Bell	
2002/0150478	A1 *	10/2002	Aoki .....	417/44.1
2003/0005706	A1	1/2003	Bell	
2003/0024924	A1	2/2003	Fristedt	
2003/0029173	A1	2/2003	Bell et al.	
2003/0079770	A1	5/2003	Bell	
2003/0084935	A1	5/2003	Bell	
2003/0102699	A1 *	6/2003	Aoki et al. ....	297/180.14
2003/0150229	A1	8/2003	Aoki et al.	
2004/0036326	A1 *	2/2004	Bajic et al. ....	297/180.14

FOREIGN PATENT DOCUMENTS

DE	199 20 451	A1	12/1999
DE	199 54 978	C1	1/2001
DE	100 01 314	A1	7/2001
DE	100 24 880	C1	9/2001
EP	0 517 615	A1	12/1992
EP	0 936 105	A1	8/1999
EP	1 075 984	A2	2/2001
EP	1 075 984	B1	5/2003
FR	1266925		9/1960
FR	2 630 056		10/1989
JP	5277020		10/1993
JP	5-277020		10/1993
JP	10044756		2/1998

JP	2002125801	2/2002
JP	2003042594	2/2003
WO	WO 02/06914	A1 1/2002
WO	WO 03/015583	A2 2/2003

OTHER PUBLICATIONS

Seat Heating Systems, Kongsberg Automotive, believed to be from website <http://www.kongsberg-automotive.no/>.

Automotive Heated Seats—Heated Steering Wheels, IGB Automotive Ltd., received by Assignee W.E.T. Automotive Systems on or about May 2003.

GMT 830 Heating & Ventilation System, IGB Automotive Ltd., received by Assignee W.E.T. Automotive Systems on or about Jun. 2003.

Komfortabel bei jeder Temperatur.

Excerpt from website <http://www.seatcomfort.com/semashow1.htm>, Specializing in Seat Ventilation and Heating Systems, Seat Comfort Systems Unveils 3 New Seat Heater Products.

Excerpt from website <http://www.seatcomfort.com/ventilation.htm>, Specializing in Seat Ventilation and Heating Systems, Ventilation.

Excerpt from website [http://www.i-car.com/html\\_pages/about\\_icar/current\\_events\\_news/advantage/advantage](http://www.i-car.com/html_pages/about_icar/current_events_news/advantage/advantage) I-Car Advantage Online.

International Search Report for Application Serial No. PCT/US03/19929 dated Oct. 10, 2003.

Copending U.S. Appl. No. 09/755,506 filed Jan. 5, 2001.

Copending U.S. Appl. No. 09/755,637 filed Jan. 5, 2001.

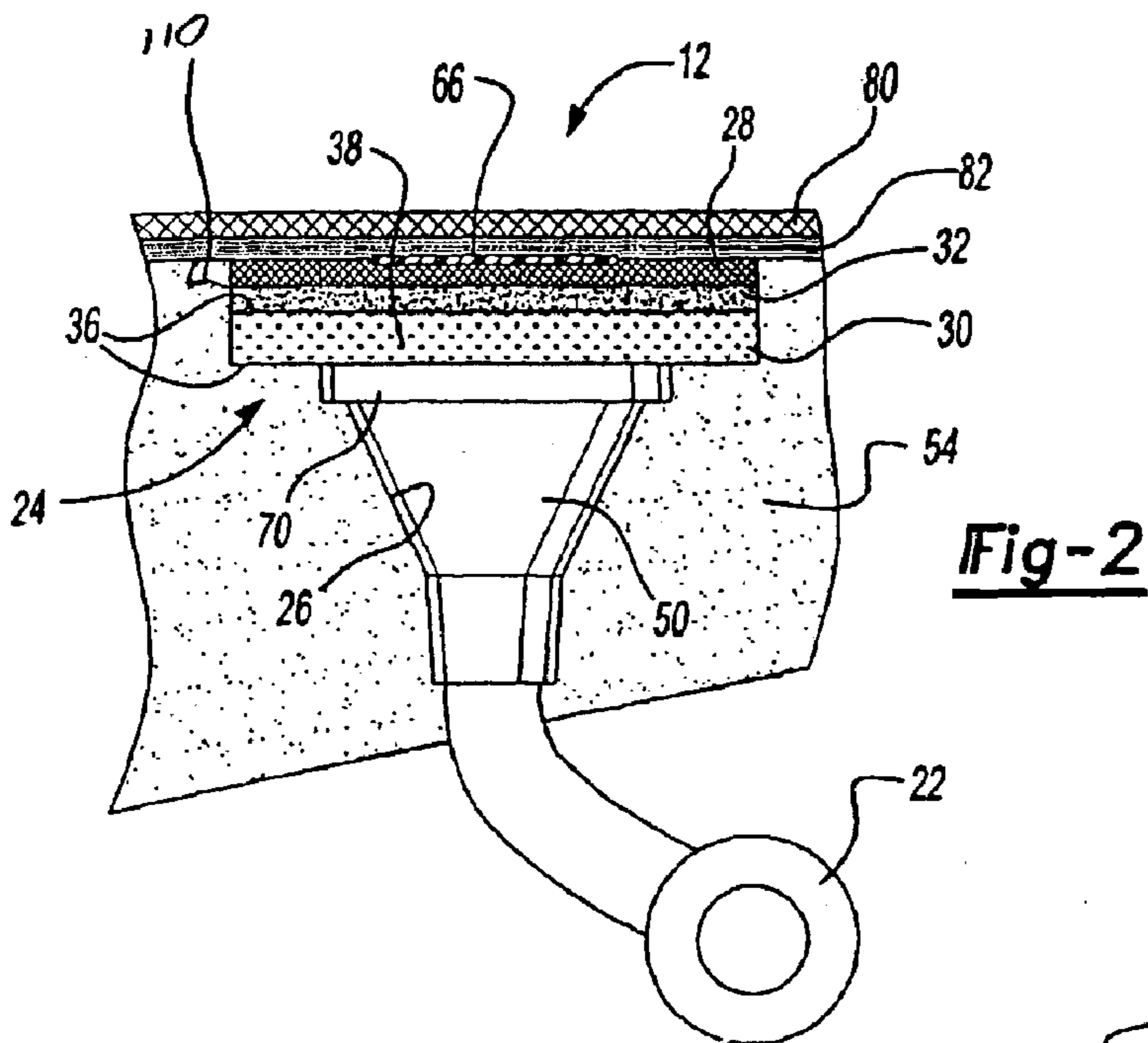
Copending U.S. Appl. No. 09/755,505 filed Jan. 5, 2001.

Copending U.S. Appl. No. 10/434,890 filed May 9, 2003.

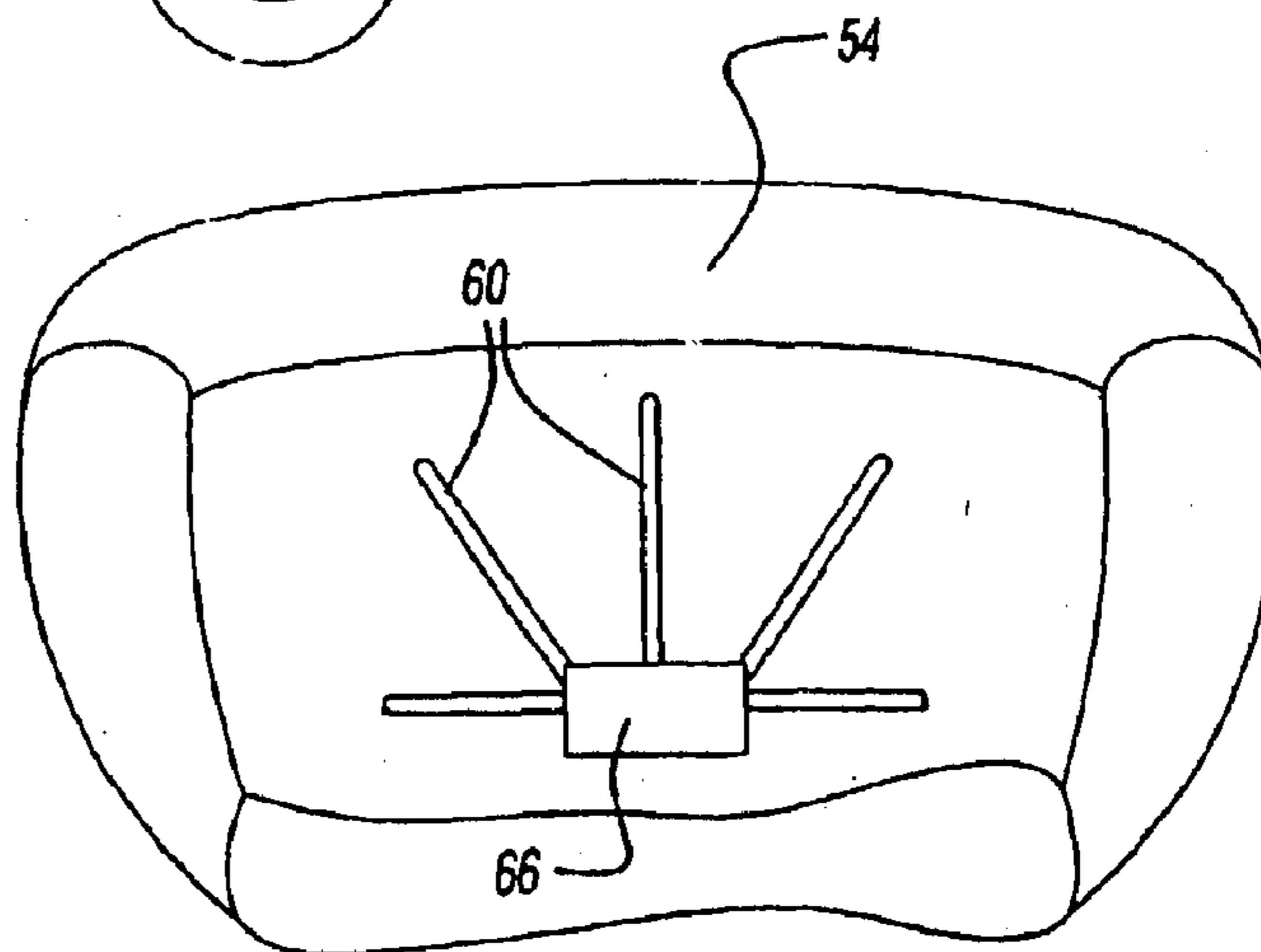
Copending U.S. Appl. No. 09/619,171 filed Jul. 19, 2000.

\* cited by examiner

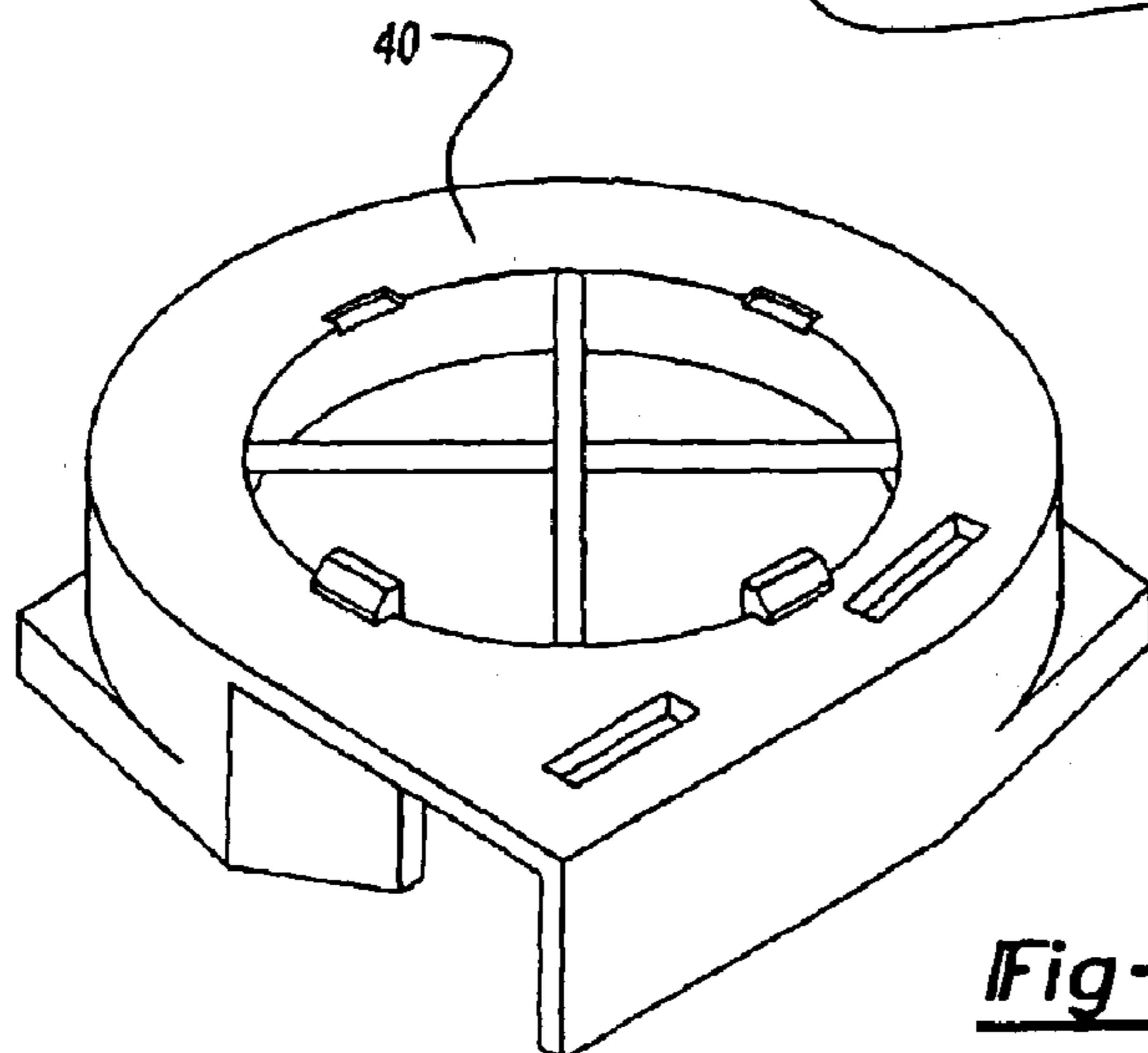




**Fig-2**



**Fig-3**



**Fig-4**

1

## AUTOMOTIVE VEHICLE SEATING COMFORT SYSTEM

### CLAIM OF PRIORITY

The present invention claims the benefit of the priority of U.S. Provisional Applications Ser. No. 60/407,198 filed Aug. 29, 2002 and Ser. No. 60/428,003 filed Nov. 21, 2002, the contents of which are incorporated by reference herein for all purposes.

### FIELD OF THE INVENTION

The present invention relates generally to automotive vehicle seats, and more particularly to seating comfort system for providing heating, cooling, ventilation or a combination thereof to an occupant of a seat of an automotive vehicle.

### BACKGROUND OF THE INVENTION

For many years the transportation industry has been concerned with designing seats for automotive vehicles that provide added comfort to occupants in the seats. Various innovations in providing seating comfort are discussed in U.S. Pat. Nos. 6,064,037; 5,921,314; 5,403,065; 6,048,024 and 6,003,950, all of which are expressly incorporated herein by reference for all purposes. In the interest of continuing such innovation, the present invention provides an improved seating system, insert for a seat or both, which are preferably suitable for employment within or as part of an automotive vehicle seat and which assist in providing comfort control to an occupant in the seat.

There is believed to be a need for an improved system for seating comfort pursuant to which an insert (which is not encapsulated or otherwise sealed along its edges) is provided for performing the seating comfort functions. There is also believed to be a need for a system in which a blower is employed for applying positive pressure to blow air with a comfort system.

### SUMMARY OF THE INVENTION

Accordingly, the present invention provides a ventilated seat having a seating comfort system. The vehicle seat includes a seat cushion component and a seat backrest component, at least one of which provides a seat cushion and an air-permeable trim surface at the occupant contact areas of the seat. The system includes an insert located beneath the trim surface of each ventilated component. The insert includes a first layer having a heater integrated therein and a second layer formed of spacer material wherein the second layer defines an open space. The system also includes a positive pressure blower in fluid communication with the insert for moving air through the open space and at least partially past an occupant in the seat. A tubular structure is preferably provided in the system for providing the fluid communication between the insert and the fluid mover.

### BRIEF DESCRIPTION OF THE DRAWINGS

The features and inventive aspects of the present invention will become more apparent upon reading the following detailed description, claims and drawings, of which the following is a brief description:

FIG. 1 is a cut-away perspective view of a vehicle seat having a comfort system in accordance with an exemplary aspect of the present invention;

FIG. 2 is a sectional view of a portion 2—2 of the vehicle seat of FIG. 1;

2

FIG. 3 is a perspective view of a seat cushion suitable for use in a comfort system in accordance with an exemplary aspect of the present invention; and

FIG. 4 is a perspective view of an exemplary blower housing suitable for application in the system of the present invention.

### DETAILED DESCRIPTION OF THE INVENTION

The present invention is predicated upon providing a seating system for an automotive vehicle wherein the system is configured to provide heating, cooling, ventilation or a combination thereof to an occupant in a seat. The system will typically include an insert having a heater and a fluid or air blower (preferably one in which fluids are displaced by blowing under a positive pressure). The system may also include a structure for facilitating fluid communication between the insert and the blower. The insert will typically include at least one layer, but more typically includes multiple (e.g., two or three or more) layers. One of the layers incorporates a heater and is therefore referred to herein as a heater layer. Preferably, one or more of the layers is a spacer layer for providing open space for fluid flow within and through the insert.

Referring to FIGS. 1 and 2, there is illustrated a vehicle seat 10 having a pair of exemplary seating comfort systems 12, 14 according to a preferred aspect of the present invention. As shown, one system 12 may be located in a seat cushion component 16 of the seat 10 while the other system 14 may be located in a seat backrest component 18 of the seat 10. Either of the systems may be omitted as well. The systems 12, 14 are substantially identical to each other, and therefore, the discussion shall focus on the system 12 in the seat cushion component 16 of the seat 10. It shall be understood, however, that multiple systems may be employed in one seat and the systems may be associated with or incorporated into the seat cushion component 16, the seat backrest component 18, other portions of the seat 10 or a combination thereof.

The system 12 includes a fluid mover shown as a blower 22 in fluid communication with an insert 24 via a duct (e.g., a tubular structure) 26. By "tubular" as used herein, the shape of the tube may vary and can be rounded, have edges, corners or the like. The insert 24 typically includes multiple layers laminated together and preferably includes a heater for providing warmth to a seat occupant and an open space for ventilation fluid flow. In the preferred embodiment, the insert 24 includes a heater layer 28 and a spacer layer 30, which are laminated and adhered together with an adhesive or adhesive layer 32. A preferred construction is one in which the insert is open at its sides and is not encapsulated.

Various different types of heaters are suitable for incorporation into a car seat and it is contemplated that any of such heaters may be incorporated into the insert 24 of the present invention. Such heaters typically incorporate flexible electrical substantially flat heating elements. As examples, a lay-wire heater, a carbon fiber heater or the like, which are typically supported with a backing (e.g., a cloth or fabric type backing) may be used within the insert. In a preferred embodiment, the heater layer 28 is a carbon fiber type heater with a backing (e.g., a non-woven layer). Preferably, the heater layer, the backing or both are breathable for allowing air to pass therethrough. One exemplary preferred heater is sold under the tradename CARBOTEX® and is commercially available from W.E.T. Automotive Systems, Inc. in Germany and/or FTG Fraser-Technik GmbH, Schleizer

Strasse 56-58, D-95028 Hot/Saale, Germany. An example of such a heater is disclosed in U.S. Pat. No. 6,064,037, issued May 16, 2000, herein expressly incorporated by reference for all purposes.

It is contemplated that a buffer layer may be incorporated into the insert **24** adjacent the heater layer **28**. Preferably, the buffer layer is a layer of gauze which is capable of protecting the heater layer **24** although various alternative protective materials may be used such as cloth, fleece or the like. Just like the other layers, it is preferable that the buffer layer is breathable or permeable for allowing fluid flow there-through.

The adhesive of the insert **24** may be supplied in layers, drops or in a variety of other configurations. In the preferred embodiment depicted, the adhesive layer **32** of the insert **24** is disposed between the heater layer **28** and the spacer layer **30** for adhering the layers **28**, **30** together. The adhesive layer **32** is preferably formed of a hot melt adhesive, although it is not necessarily required, and may be other adhesives as well. The adhesive may be provided as a web or otherwise and may be continuous or non continuous (e.g., may be applied in drops, dabs or the like). The adhesive layer **32** may include an adhesive selected from polyamides, polyesters, elastomers, vinyl acetates, acrylics, urethanes, olefin polymers or a combination thereof. Moreover, the adhesive may be formulated as desired for particular processing parameters or conditions. Preferably, the adhesive layer is substantially free of anti-blocking solutions, blowing additives, process contaminants or the like which might interfere with adhesive performance. As an example, one suitable hot melt adhesive is commercially available as a non-woven web under the tradename SPUNFAB® from Spunfab, Ltd. 175 Muffin Lane, Cuyahoga Falls, Ohio 44223.

The spacer layer **30** is preferably formed of a spacer material. The spacer material may be provided as a variety of synthetic materials such as plastic or polymeric materials, padding and stuffing materials, lining and carrier materials or the like. Preferably, the spacer material provides open space within the layer **30** while remaining at least partially pliable or flexible. As one example, the spacer layer may be provided as a plurality of rubber, foam plastic or other members or fibers. The members or fibers are preferably spaced apart from each other to provide open space therebetween while still being close enough together to provide cushion and support. As another example the spacer layer **30** may be formed of a 3-dimensional spacer fabric structure or material.

In the preferred embodiment depicted, the spacer layer **30** is formed of polymeric (e.g., polyester) strand material that is interwoven to provide opposing honeycomb structures **36** (e.g., fabric panels), which are interconnected by several additional polymeric strand materials to provide open space **38** between the structures **36** while still providing cushion and support. As an example, one preferred material is sold under the tradename 3MESH® and is commercially available from Müller Textil GmbH, Germany or Müller Textiles, Inc., Rhode Island, USA. In a particularly preferred embodiment, one or more of the honeycomb structures **36** include a finer filament polymeric strand material than the rest of spacer layer **30** for assisting adhesion of the spacer layer **30** to other materials.

The blower **22** of FIGS. 1 and 2, a housing **40** of which is shown in FIG. 4 (e.g., adapted for snap fit connection to a mounting surface), may be positioned in a variety of locations within or outside the seat **10**. Moreover, it is

contemplated that the blower **22** may be secured to the seat **10** or to other vehicle components with a variety of attachments (e.g., fasteners, sewing, mating threaded attachments, quick connects, snap fits or the like). Further, it is contemplated that the blower **22** may include fingerguards, deflectors or the like.

The tubular structure **26** may be supplied in a variety of configurations and may be integrated with or separate from a variety of components (e.g., the seat, the insert, the blower or the like) and preferably provides for fluid communication between the insert **24** and the blower **22**. As an example, it is contemplated that the tubular structure **26** may be integrated into portions of the seat **10** such as the foam cushions. As an alternative example, the tubular structure may be supplied as a separate component (e.g., a separate preferably flexible tube). As still another alternative example, the tubular structure may be integral with the insert **24**, the blower **22**, the seat **10** or a combination thereof. It is also contemplated that the tubular structure may be provided as a combination of any of the above examples.

In FIGS. 1 and 2, the tubular structure **26** is provided by a foam cushion **34** of the seat **10** and the structure **26** defines a passageway **50** (e.g., through-hole) extending through the foam cushion **54** for interconnecting the insert **24** and the blower **22** and providing fluid communication therebetween. As shown, particularly in FIG. 1, such a tubular structure **26**, (e.g., including an enlarged passageway **50**) may extend through the foam cushion in either the seat cushion component **16** or the seat backrest component **18** of the seat **10**. In the embodiment depicted, fluid communication between the tubular structure **26** and the blower **22** and fluid communication between the tubular structure **26** and the insert **24** are substantially direct, however, such is not necessarily required. In a highly preferred embodiment, a portion of a wall of the tubular structure **26** nearest the forward edge of the seat cushion component **16** is at an angle between about 20 degrees and about 60 degrees (e.g., about 45 degrees) relative to another portion of the wall of the tubular structure **26** that is nearest a rearward edge of the seat cushion component **16**.

Preferably, the tubular structure **26** provides a substantially fluid-tight (e.g., air tight) connection with the insert **24**. To aid in this, the enlarged portion **50** may be formed, in dense form or as a foam. The walls of the tubular structure **26** are preferably coated or lined with a densified layer, such as by providing the tubular structure **26** (e.g., foam walls) with a coating such as a silicon coating, or by providing the tubular structure **26** with a lining (e.g., a polymer lining, a tape lining or the like).

As an additional option, the system **10** of the present invention may include one or more additional sub-passageways or openings for assisting in guiding fluid flow between the blower **22** and the insert **24**. The sub-passageways may be defined by structures separate from the seat **10** or the insert **24** or may be integral therewith. In FIG. 3, a plurality of sub-passageways **60** are supplied as channels that are formed in the foam cushion **54**. Preferably, the sub-passageway **60** extends radially away from the passageway **50** through the cushion **54**. Also, as shown in FIG. 3, it is contemplated that a deflector **66** (e.g., a strip of tape) may be placed over the passageway **50** of the cushion **54** for assisting in directing fluid radially away from the passageway **50** and particularly through the sub-passageways **60**.

The insert **24** is preferably assembled to the seat **10** by placing the insert **24** in overlaying relation with the cushion **54** such that the insert **24** covers the passageway **50**, the

sub-passageways **60** or both. In the depicted embodiment, a support **70** (e.g., a plastic panel with through-holes extending therethrough) is placed over the passageway **50** for providing continuity of support along with the cushion **54**. The insert **24** is then placed within one or more cavities **74** in the cushion **54**.

The insert **24** may be positioned upon the cushion **54** in a pre-assembled condition or the components or layers (e.g., the spacer layer, the adhesive layer, the heater layer or combinations thereof) may be applied separately. In a preferred embodiment, the spacer layer **30** is laminated to the heater layer **28** with the adhesive layer **32** therebetween to adhere the spacer layer **30** to the heater layer **28**. It is contemplated that lamination may be effected by feeding the various layers **28, 30, 32** to a laminator (e.g., a belt and roller laminator, a stationary laminator or the like) or otherwise. If desired, the insert **24** may be adhered, fastened or otherwise attached to the cushion **54** of the seat **10**.

One or more trim layers **80, 82** are assembled to the seat **10** to cover the cushion **54**, the insert **24** or both. Preferably, the trim layers **80, 82** are fluid (e.g., air) permeable or breathable. In the preferred embodiment, the system **12** includes an outer trim layer **80** of permeable (e.g., perforated) leather or cloth and an inner trim layer **82** that is formed of a breathable padding material. As shown, the heater layer **28** is preferably closer to the trim layers **80, 82** than the spacer layer **30** although not required.

#### Operation

In operation, the system **10** of the present invention can preferably provide heating, cooling, ventilation or a combination thereof to an occupant of a seat having the system **10**. In particular, if heat is desired, electric current can be induced to travel through the heater layer **28** by a control unit **90** or otherwise such that the heater layer **28** can provide heat to the occupant.

Alternatively, if cooling or ventilation is desired, the blower **22** can be operated via the control unit **90** or otherwise to blow air through the passageway **50**, the sub-passageways **60** or both and through the open space **38** of the spacer layer **30** of the insert **24**. Such air preferably flows at least partially past the occupant of the seat before or after flowing through the trim layers **80, 82** thereby providing ventilation to the occupant and providing convective heat transfer away from the occupant via the flowing air.

Although, it may be preferable for only the heater layer **28** or the ventilation system (i.e., the blower **22**) to be running at one time, it is contemplated that both may be operated simultaneously. Moreover, it is contemplated that both the heater layer **28** and the ventilation system may be operated at various levels (e.g., 2, 3 or more levels of output) such as by having a blower that can operate at different levels or by having various levels of electricity flowing through the heater layer **28**. It is also contemplated that the blower **22** may pull air into the open space **38**, the passageway **50**, the sub-passageways **60** or a combination thereof as well as pushing air into the open space **38**, the passageway **50**, the sub-passageways **60** or a combination thereof.

It is also contemplated that one or more temperature sensors (e.g., a thermostat) may be included in the seating comfort system. Typically, any temperature sensors are near the trim layers **80, 82** for sensing a temperature closely related to (e.g., at or near) a temperature being experienced by an individual in the seat. In a preferred embodiment, one or more temperature sensors are positioned upon the heater layer **28** or upon the heater element of the heater layer. Also in the preferred embodiment, the one or more temperature

sensors are in signaling communication with the control unit **90** such that the control unit **90** can control the blower **22**, the heater layer **28** or both for attaining or maintaining a desired temperature at areas adjacent the individual and/or the temperature sensor.

In the preferred embodiment shown, the comfort control system **10** includes a temperature sensor **110** just below the trim layers **80, 82** and in signaling communication with the control unit **90**. Advantageously, the control unit **90** is programmed to instruct the system **10** to provide less heat and even cooling in situations where the sensor **110** senses a temperature above one or more predetermined threshold levels. In operation, the control unit **90** may be programmed to instruct the system to provide less cooling or even heating when the sensor **110** senses a temperature below one or more predetermined threshold levels. In a preferred operation mode, when the blower **22** is providing ventilation, the control unit **90** is programmed to instruct the heater layer **28** to turn on and provide heat while the blower **22** remains on if a first undesirably low predetermined temperature is sensed by the sensor **110**. Then, if a second predetermined temperature is sensed below the first predetermined temperature, the control unit **90** instructs the blower **22** to turn off while the heater layer **28** continues to provide heat. For each of these situations, the heater layer **28** will typically be instructed by the control unit **90** to continue to provide heat until the temperature sensed by the sensor **110** is at or above the first predetermined temperature and may provide heat until a third predetermined temperature above the first predetermined temperature is sensed.

In another preferred operation mode, when the heater layer **28** is providing heat, the control unit **90** is programmed to instruct the blower **22** to turn on and blow air while the heater layer **28** remains on if a first undesirably high predetermined temperature is sensed by the sensor **110**. Then, if a second predetermined temperature is sensed above the first predetermined temperature, the control unit **90** is programmed to instruct the heater layer **28** to turn off while the blower **22** continues to blow air. For each of these situations, the blower **22** will typically be instructed by the control unit **90** to continue to blow air until the temperature sensed by the sensor **110** is at or below the first predetermined temperature and may blow air until a third predetermined temperature below the first predetermined temperature is sensed.

The preferred embodiment of the present invention has been disclosed. A person of ordinary skill in the art would realize however, that certain modifications would come within the teachings of this invention. Therefore, the following claims should be studied to determine the true scope and content of the invention

What is claimed is:

1. A ventilated seat for a vehicle, comprising:
  - a vehicle seat having a ventilated component selected from a seat component and a backrest component, at least one of which provides a seat cushion and an air permeable trim surface at occupant contact areas;
  - an insert including a foam material and located beneath the trim surface;
  - a fluid mover in fluid communication with the insert for moving air through the foam material of the insert and the trim surface;
  - a duct for providing the fluid communication between the insert and the fluid mover, wherein the duct is at least partially provided by the seat cushion and defines a passageway through the cushion; and



7

a deflector disposed over the passageway defined by the duct that diverts the flow of fluid into a plurality of sub-passageways, wherein the sub-passageways are formed in the seat cushion and extends away from the passageway.

2. The ventilated seat of claim 1 wherein the seat cushion, the passageway, the sub-passageways, or combinations thereof include an air impermeable lining or coating.

3. The ventilated seat of claim 2 wherein the fluid mover is a blower configured to push air through the trim surface.

4. The ventilated seat of claim 3, further comprising a heater layer.

5. The ventilated seat of claim 4, wherein the insert is a multi-layer laminate.

6. The ventilated seat of claim 2, wherein the ventilated component further comprises at least one temperature sensor.

7. The ventilated seat of claim 6, further comprising a control unit in signaling communication with the temperature sensor, the fluid mover, the heater layer or combinations thereof.

8. The ventilated seat of claim 1, further comprising a spacer material located between the trim surface and the insert, the spacer material defining an open space.

9. The ventilated seat of claim 8, wherein the fluid mover is in fluid communication with the spacer material for moving air through the open space and the trim surface.

10. The ventilated seat of claim 8, wherein the spacer material includes a polymeric strand material.

11. The ventilated seat of claim 1 wherein the duct is a flexible duct.

12. A ventilated seat for a vehicle, comprising:

a vehicle seat having a ventilated component selected from a seat component and a backrest component, at least one of which provides a seat cushion and an air permeable trim surface at occupant contact areas;

an insert including a foam material and located beneath the trim surface;

a blower in fluid communication with the insert for moving air through the insert and the trim surface;

a duct for providing the fluid communication between the insert and the blower, wherein the duct is at least partially provided by the seat cushion and defines a passageway through the cushion; and

a deflector disposed over the passageway defined by the duct that diverts the flow of fluid into a plurality of sub-passageways that extends away from the passageway,

8

wherein the seat cushion, the duct, the sub-passageways, or combinations thereof include an air impermeable lining or coating.

13. The ventilated seat of claim 12, further comprising a spacer material located between the trim surface and the insert, the spacer material defining an open space.

14. The ventilated seat of claim 13, wherein the fluid mover is in fluid communication with the spacer material for moving air through the open space and the trim surface.

15. The ventilated seat of claim 13, wherein the spacer material includes a polymeric strand material.

16. The ventilated seat of claim 12, further comprising at least one temperature sensor.

17. The ventilated seat of claim 12, further comprising a control unit in signaling communication with the temperature sensor, the fluid mover, the heater layer or combinations thereof.

18. A ventilated seat for a vehicle, comprising:

a vehicle seat having a ventilated component selected from a seat component and a backrest component, at least one of which provides a seat cushion and an air permeable trim surface at occupant contact areas;

an insert including a foam material and located beneath the trim surface;

a spacer material located between the trim surface and the insert, the spacer material defining an open space;

a blower in fluid communication with the insert for moving air through the insert, the open space and the trim surface;

a duct for providing the fluid communication between the insert and the blower, wherein the duct is at least partially provided by the seat cushion and defines a passageway through the cushion; and

a deflector disposed over the passageway defined by the duct that diverts the flow of fluid into a plurality of sub-passageways that extends away from the passageway,

wherein the seat cushion, the duct, the sub-passageways, or combinations thereof include an air impermeable lining or coating.

\* \* \* \* \*

UNITED STATES PATENT AND TRADEMARK OFFICE  
**CERTIFICATE OF CORRECTION**

PATENT NO. : 6,857,697 B2  
DATED : February 22, 2005  
INVENTOR(S) : Brennan et al.

Page 1 of 1

It is certified that error appears in the above-identified patent and that said Letters Patent is hereby corrected as shown below:

Title page.

Item [75], Inventors, replace "**Drobnajakovic**" with -- **Drobnjakovic** --.

Signed and Sealed this

Twenty-eighth Day of June, 2005

A handwritten signature in black ink on a light gray dotted background. The signature reads "Jon W. Dudas" in a cursive style.

JON W. DUDAS

*Director of the United States Patent and Trademark Office*