



US006835022B2

(12) **United States Patent**
Hightower

(10) **Patent No.:** **US 6,835,022 B2**
(45) **Date of Patent:** **Dec. 28, 2004**

(54) **CONNECTOR FOR JOINING TOE KICK
PLATE OF CABINET**

(75) Inventor: **Robert C. Hightower**, High Point, NC
(US)

(73) Assignee: **Tenn-Tex Plastics, Inc.**, Colfax, NC
(US)

(*) Notice: Subject to any disclaimer, the term of this
patent is extended or adjusted under 35
U.S.C. 154(b) by 7 days.

5,746,490 A	5/1998	Domenig	312/334.5
5,823,648 A	10/1998	Domenig	312/334.5
5,833,337 A	11/1998	Kofstad	312/334.5
5,904,412 A	5/1999	Lammens	312/334.7
6,010,200 A	1/2000	Hays	312/334.7
6,070,957 A	6/2000	Zachrai	312/334.4
6,155,660 A	12/2000	Nicolai	312/223.1
6,270,281 B1	8/2001	Ruusuvuori	403/11
6,273,534 B1	8/2001	Bueley et al.	312/334.8
6,367,900 B1	4/2002	Woerner	312/334.5
6,402,276 B1	6/2002	King	312/334.7
6,422,399 B1	7/2002	Castillo et al.	211/26
6,494,550 B1	12/2002	Chen et al.	312/334.5

* cited by examiner

(21) Appl. No.: **10/195,110**

(22) Filed: **Jul. 12, 2002**

(65) **Prior Publication Data**

US 2004/0009035 A1 Jan. 15, 2004

(51) **Int. Cl.**⁷ **F16B 7/00**

(52) **U.S. Cl.** **403/403; 403/205; 403/345**

(58) **Field of Search** **403/403, 345-383,**
403/205; 312/228, 278

(56) **References Cited**

U.S. PATENT DOCUMENTS

3,119,643 A	1/1964	Levi et al.	312/343
4,381,876 A	* 5/1983	Fenwick	312/114
4,383,397 A	5/1983	Ward	52/254
4,724,561 A	* 2/1988	Falwell et al.	5/658
5,039,181 A	8/1991	Lautenschlager	312/343
5,310,255 A	5/1994	Ranallo	312/334.5
5,457,867 A	10/1995	Maberry et al.	29/525
5,597,220 A	1/1997	Domenig et al.	312/334.4
5,647,687 A	7/1997	Robinson et al.	403/403

Primary Examiner—Daniel P. Stodola
Assistant Examiner—Carlos Lugo

(74) *Attorney, Agent, or Firm*—Myers Bigel Sibley &
Sajovec

(57) **ABSTRACT**

A connector for an enclosure comprises: a main panel having inner and outer surfaces and a front end; a toe kick support panel extending generally perpendicularly from an intermediate portion of the inner surface of the main panel; a toe kick retaining flange extending generally perpendicularly from the front end of the inner surface of the main panel, the toe kick retaining flange, the toe kick support panel, and the main panel inner surface defining an open toe kick channel; and a side edge retaining flange extending generally perpendicularly from the front end of the outer surface of the main panel. In certain embodiments, the toe kick retaining flange and the side edge retaining flange are directly opposite each other across the main panel.

25 Claims, 1 Drawing Sheet

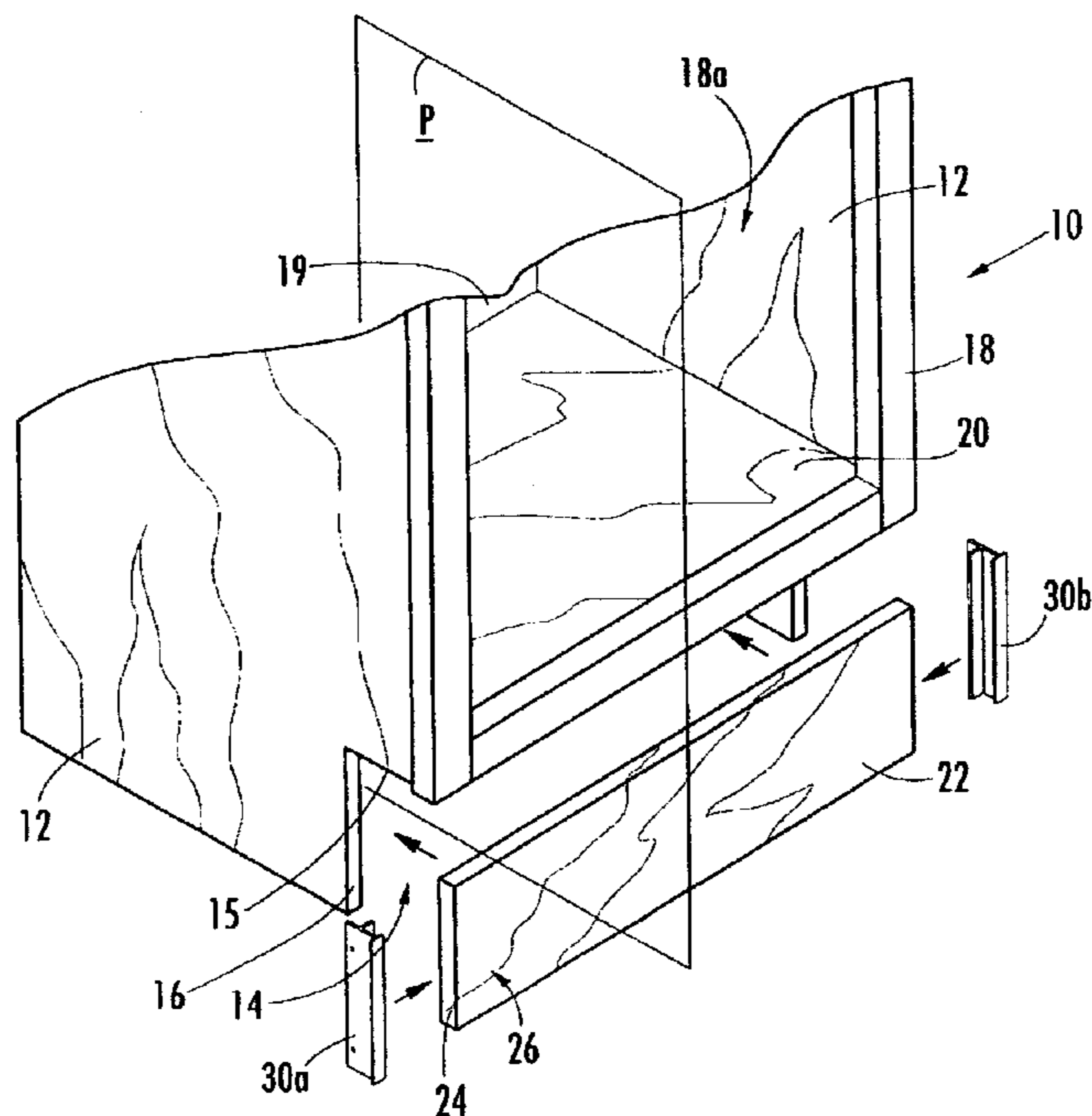

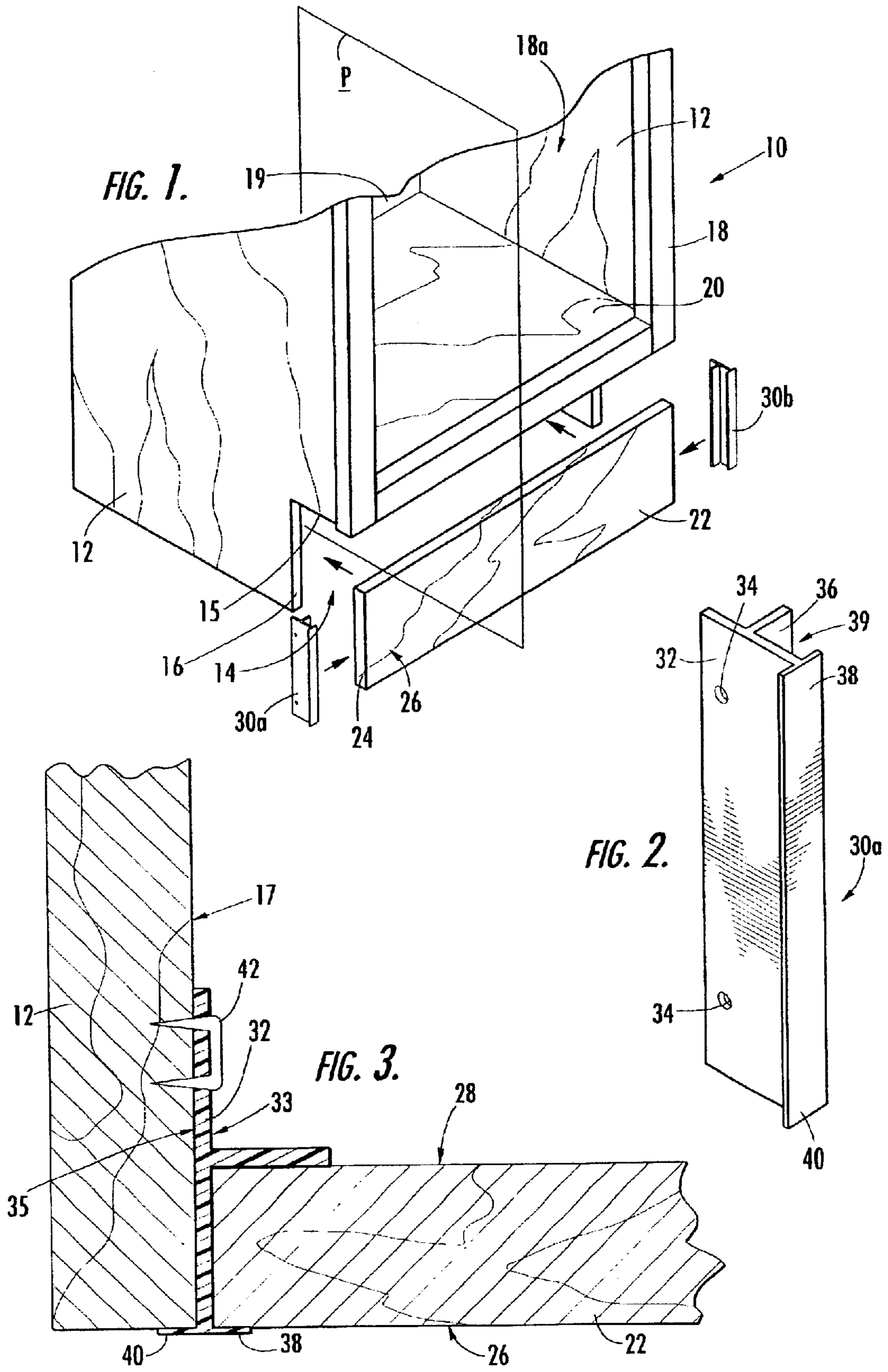

1

CONNECTOR FOR JOINING TOE KICK PLATE OF CABINET

FIELD OF THE INVENTION

The present invention is directed generally to furniture, and more particularly to cabinets.

BACKGROUND OF THE INVENTION

Many cabinets, particularly those found in kitchens and bathrooms, include a central storage cavity that is raised a few inches from the underlying surface. Such cabinets often include a floor that defines the bottom of the storage cavity, and are designed such that the front portion of the cabinet beneath the floor is recessed rearwardly from the front frame of the cabinet. This configuration enables a person to stand close to the front of the cabinet to, for example, use a sink or peer into a mirror; because the lower front portion of the cabinet is recessed, the person's feet can fit into the space, enabling the person to be positioned closer to the sink or mirror than would otherwise be the case.

Typically, such cabinets have a panel, called a "toe kick plate," that covers the recessed front lower portion of the cabinet. The toe kick plate is attached to the front edges of the side walls (usually to cutaway sections located on the lower front portions of the side walls). Traditionally, the toe kick plate and the side walls were joined with a wooden block that was nailed to the inner surfaces of the toe kick plate and the side walls. However, joints of this configuration can be prone to having gaps between the walls, which may enable pests to enter the cabinet. In addition, installation of the toe kick plate can be rather cumbersome with this joining technique.

To address this undesirable situation, plastic connectors for toe kick plates were developed; an exemplary connector is illustrated in U.S. Pat. No. 5,647,687 to Robinson et al. This connector includes perpendicular flanges that overlie the inner surfaces of the side walls and toe kick plate. A small retaining portion overlies the end of the outer surface of the toe kick plate, such that the toe kick plate is retained between the flange and the retaining portion. The flange that overlies the inner surface of the side wall is fastened thereto, usually with screws, nails, or staples. A hollow, generally rectangular body portion is positioned in front of the front edge of the side wall and outwardly from the outer edge of the toe kick plate and serves to fill the gap between these edges. The connector tends to fill the gaps between the toe kick plate and the side walls to prevent pest entry and is relatively easy to install, as the operator can simply position each end of the toe kick plate between the retaining portion and associated flange, place the other flange against the side walls of the cabinet, and quickly fasten them in place. This configuration may also facilitate replacement of the toe kick plate if necessary.

Although this connector has generally been popular, it has some shortcomings for some cabinets. For example, some customers may prefer the appearance of wood to that of the plastic connector, which covers the front edge of the side wall. As such, it would be desirable to provide a connector that can easily join a toe kick plate to the side walls of a cabinet but allows much of the front edge of the side wall to be visible.

SUMMARY OF THE INVENTION

The present invention is directed to an enclosure, such as a cabinet, that includes a connector that joins a front panel,

2

like a toe kick plate, to a side wall. The enclosure comprises: a pair of side walls, each of the side walls extending longitudinally and having a front edge and an inner surface; a front plate extending transversely and having a front surface, a rear surface, and a pair of opposed side edges; and a connector. The connector comprises: a main panel having inner and outer surfaces and a front end, the outer surface overlying the inner surface of a first one of the side walls; a first support panel extending generally perpendicularly from an intermediate portion of the inner surface of the main panel and overlying the rear surface of the front plate; a first retaining flange extending generally perpendicularly from the front end of the inner surface of the main panel and overlying the front surface of the front plate; and a second retaining flange extending generally perpendicularly from the front end of the outer surface of the main panel and overlying the side edge of the first side wall. The enclosure further comprises a fastener fixing the connector to the first side wall extending through the main panel and into the first side wall. In this configuration, the toe kick plate or other front panel can be easily connected to the side walls with the connector and can visually display the side edge of the side wall.

In one embodiment, a connector for such an enclosure comprises: a main panel having inner and outer surfaces and a front end; a toe kick support panel extending generally perpendicularly from an intermediate portion of the inner surface of the main panel; a toe kick retaining flange extending generally perpendicularly from the front end of the inner surface of the main panel, the toe kick retaining flange, the toe kick support panel, and the main panel inner surface defining an open toe kick channel; and a side edge retaining flange extending generally perpendicularly from the front end of the outer surface of the main panel. In certain embodiments, the toe kick retaining flange and the side edge retaining flange are directly opposite each other across the main panel.

BRIEF DESCRIPTION OF THE FIGURES

FIG. 1 is a front, exploded, perspective view of a cabinet of the present invention.

FIG. 2 is a perspective view of a connector forming a part of the cabinet of FIG. 1.

FIG. 3 is a top, cross-sectional view of the cabinet of FIG. 1.

DETAILED DESCRIPTION OF THE INVENTION

The present invention will now be described more fully hereinafter, in which preferred embodiments of the invention are shown. This invention may, however, be embodied in different forms and should not be construed as limited to the embodiments set forth herein. Rather, these embodiments are provided so that this disclosure will be thorough and complete, and will fully convey the scope of the invention to those skilled in the art. In the drawings, like numbers refer to like elements throughout. Thicknesses and dimensions of some components may be exaggerated for clarity.

The present invention relates to a cabinet having a horizontal floor and vertical side and rear walls that define a portion of an access opening for the cabinet. As used herein, the terms "forward", "front" and derivatives thereof refer to the direction defined by a vector extending from the rear wall toward the access opening parallel to the floor. Conversely, the terms "rearward" and derivatives thereof

refer to the direction directly opposite the forward direction; i.e., the rearward direction is defined by a vector that extends from the access opening toward the rear wall parallel to the floor. The forward and rearward directions together comprise the “longitudinal” directions relative to the cabinet. The term “outward” and derivatives thereof refer to the direction defined by a vector originating in the center of the floor and extending in the plane of the floor and perpendicular to the forward and rearward directions. The terms “inboard”, “inward” and derivatives thereof refer to the direction directly opposite to the lateral direction as defined hereinabove. The outward and inward directions together comprise the “lateral” directions relative to the cabinet.

Referring now to the figures, a cabinet, designated broadly at **10**, is shown in FIG. **1**. The cabinet **10** includes a pair of longitudinally-extending side walls **12**, a transversely-extending front frame **18**, a rear wall **19**, a horizontal floor **20**, and a transversely-extending toe kick plate **22**. Each side wall **12** includes a cutaway section **14** in its lower front corner. The front frame **18**, which is typically formed of multiple planks joined at their ends to form an open rectangle that serves as an access opening **18a**, extends transversely between and is attached to the front edges of the side walls **12**, with its lower edge essentially even with the upper edges **15** of the side wall cutaway section **14**. The floor **20** is mounted between the side walls **12** at approximately the level of the cutaway section upper edges **15**. The toe kick plate **22** is mounted vertically and extends transversely between the cutaway section front edges **16**.

Although the cabinet **10** is illustrated herein, those skilled in this art will appreciate that other enclosures, such as chests, bins, bureaus, vanities, and the like, that include a toe kick plate or similar front panel may also be suitable for the present invention. In some embodiments, the side walls **12** may lack the cutaway sections **14**, such that the toe kick plate **22** or other front panel is not recessed in the manner exemplified by the cabinet **10**.

As can be seen in FIGS. **1** through **3**, the toe kick plate **22** is joined to the side walls **12** with connectors **30a**, **30b** attached at either end. Because the connectors **30a**, **30b** are mirror images of each other about a vertical plane **P** that is located equidistant between the side walls **12**, only one connector **30a** and its interaction with the toe kick plate **22** will be described in detail below; those skilled in this art will appreciate that this discussion applies equally to the other connector **30b** as well.

Referring now to FIGS. **2** and **3**, the connector **30a** is of substantially constant cross-section when viewed from the vantage point of FIG. **3**. The connector **30a** includes a main panel **32** that extends generally longitudinally. A toe kick support panel **36** extends inwardly and substantially perpendicularly from the central portion of the inner surface **33** of the main panel **32**. A toe kick retaining flange **38** extends inwardly from the front end of the main panel **32**, thereby forming a toe kick channel **39** with the front portion of the main panel **32** and the toe kick support panel **36**, the toe kick channel **39** being open in the inward direction. The toe kick channel **39** is of a width that is slightly larger than the width of the toe kick plate **22** (typically between about $\frac{3}{8}$ and $\frac{3}{4}$ inches). A side edge retaining flange **40** extends outwardly from the front end of the main panel **32** directly opposite from and substantially coplanar with the toe kick retaining flange **38**. A pair of apertures **34** are present in the rear portion of the main panel **32**.

The connector **30a** is typically and illustratively constructed such that the main panel **32** and the toe kick support

panel **36** are of approximately the same thickness (either or both is typically between about 0.060 and 0.125 inches in thickness), and the inward and outward flanges **38**, **40** are of approximately the same thickness (either or is typically between about 0.025 and 0.050 inches in thickness) and relatively thinner than the main panel **32** and the toe kick support panel **36**. It is preferred that the toe kick support panel extends farther inwardly than the toe kick retaining flange. The connector **30a** is typically formed as a unitary member and from a polymeric material, such as polystyrene or ABS, but may be formed of other materials and may be formed in multiple pieces as desired.

Referring now to FIG. **3**, the connector **30a** joins the toe kick plate **22** with the side walls **12** as illustrated therein. The side edge **24** of the toe kick plate **22** is captured in the toe kick channel **39** and is captured therein, with the front surface **26** of the toe kick plate **22** overlying the rear surface of the toe kick retaining flange **38** and the rear surface **28** of the toe kick plate **22** overlying the front surface of the toe kick support panel **36**. The rear surface of the side edge retaining flange **40** overlies the front edge **16** of the side wall cutaway section **14**. The outward surface **35** of the main panel **32** overlies the inner surface **17** of the side wall **12**. The main panel **32** can be fixed to the side wall **12** via staples **42** as illustrated or with other fasteners, such as screws, inserted through the apertures **34**. Notably, typically no other fasteners are needed to secure the toe kick plate **22** to the side walls **12**.

In this configuration, the front edges **16** of the cutaway section **14** are substantially coplanar with the front surface **26** of the toe kick plate **22**. As such, they may be visible (which may be desirable) rather than covered as is the case with the connector illustrated in U.S. Pat. No. 5,647,687 to Robinson et al. discussed above. Also, the connector **30** may require less material, and therefore be less expensive to manufacture, than the connector of the Robinson patent.

The foregoing is illustrative of the present invention and is not to be construed as limiting thereof. Although exemplary embodiments of this invention have been described, those skilled in the art will readily appreciate that many modifications are possible in the exemplary embodiments without materially departing from the novel teachings and advantages of this invention. As such, all such modifications are intended to be included within the scope of this invention. The scope of the invention is to be defined by the following claims.

That which is claimed is:

1. A connector connecting a toe kick plate to a side wall of a cabinet, the side wall having a front edge and the front edge having a front edge width, the connector comprising:
 - a main panel having inner and outer surfaces, each having a front end;
 - a toe kick support panel extending generally perpendicularly from an intermediate portion of the inner surface of the main panel;
 - a toe kick retaining flange extending generally perpendicularly from the front end of the inner surface of the main panel, the toe kick retaining flange, the toe kick support panel, and the main panel inner surface defining an open toe kick channel; and
 - a side edge retaining flange extending generally perpendicularly from the front end of the outer surface of the main panel a distance less than the front edge width such that a portion of the front edge remains exposed when the connector is mounted thereon.
2. The connector defined in claim **1**, wherein the side edge retaining flange is positioned directly opposite the toe kick retaining flange across the main panel.

5

3. The connector defined in claim 1, wherein the toe kick channel has a width between the toe kick support panel and the toe kick retaining flange, the width being between about 0.060 and 0.125 inches.

4. The connector defined in claim 1, wherein the main panel includes apertures positioned rearwardly of the toe kick support panel.

5. The connector defined in claim 1, wherein the connector is a unitary structure.

6. The connector defined in claim 1, wherein the connector is formed of a polymeric material.

7. The connector defined in claim 1, wherein the toe kick retaining flange and the side edge retaining flange are of substantially the same thickness.

8. The connector defined in claim 1, wherein the toe kick support flange and the main panel are of substantially the same thickness.

9. The connector defined in claim 1, wherein the toe kick support flange extends away from the main panel a greater distance than the toe kick retaining flange.

10. An enclosure, comprising:

a pair of side walls, each of the side walls extending longitudinally and having a front edge and an inner surface, each of the front edges having a front edge width;

a front plate extending transversely and having a front surface, a rear surface, and a pair of opposed side edges;

a connector, the connector comprising:

a main panel having inner and outer surfaces, each having a front end, the outer surface overlying the inner surface of a first one of the side walls;

a first support panel extending generally perpendicularly from an intermediate portion of the inner surface of the main panel and overlying the rear surface of the front plate;

a first retaining flange extending generally perpendicularly from the front end of the inner surface of the main panel and overlying the front surface of the front plate; and

a second retaining flange extending generally perpendicularly from the front end of the outer surface of the main panel a distance less than the front edge width such that the second retaining flange overlies the front edge of the first side wall and a portion of the front edge remains exposed; and

a fastener fixing the connector to the first side wall extending through the main panel and into the first side wall.

11. The enclosure defined in claim 10, wherein the fastener is selected from the group consisting of staples and screws.

12. The enclosure defined in claim 10, wherein the front plate comprises a toe kick plate, the first support panel comprises a toe kick support panel, the first retaining flange comprises a toe kick retaining flange, and the second retaining flange comprises a side edge retaining flange.

6

13. The enclosure defined in claim 12, wherein the side edge retaining flange is positioned directly opposite the toe kick retaining flange across the main panel.

14. The enclosure defined in claim 12, wherein the toe kick plate has a width between about 0.375 and 0.75 inches.

15. The enclosure defined in claim 12, wherein the main panel includes apertures positioned rearwardly of the toe kick support panel.

16. The enclosure defined in claim 10, wherein the connector is a unitary structure.

17. The enclosure defined in claim 10, wherein the connector is formed of a polymeric material.

18. The enclosure defined in claim 12, wherein the toe kick retaining flange and the side edge retaining flange are of substantially the same thickness.

19. The enclosure defined in claim 12, wherein the toe kick support flange and the main panel are of substantially the same thickness.

20. The enclosure defined in claim 12, wherein the toe kick support flange extends inwardly a greater distance than the toe kick retaining flange.

21. The enclosure defined in claim 12, wherein each of the side walls has a cutaway section in a lower front corner thereof, and wherein the side edge retaining flange overlies a front edge of the cutaway section of the first side wall.

22. A connector connecting a toe kick plate to side wall of a cabinet, the side wall having a front edge and the front edge having a front edge width, the connector comprising:

a main panel having inner and outer surfaces, each having a front end;

a toe kick support panel extending generally perpendicularly from an intermediate portion of the inner surface of the main panel;

a toe kick retaining flange extending generally perpendicularly from the front end of the inner surface of the main panel, the toe kick retaining flange, the toe kick support panel, and the main panel inner surface defining an open toe kick channel; and

a side edge retaining flange extending generally perpendicularly from the front end of the outer surface of the main panel directly opposite the toe kick retaining panel a distance less than the front edge width such that a portion of the front edge remains exposed when the connector is mounted thereon;

wherein the connector is a unitary structure and is formed of a polymeric material.

23. The connector defined in claim 22, wherein the toe kick retaining flange and the side edge retaining flange are of substantially the same thickness.

24. The connector defined in claim 22, wherein the toe kick support flange and the main panel are of substantially the same thickness.

25. The connector defined in claim 22, wherein the toe kick support flange extends inwardly a greater distance than the toe kick retaining flange.

* * * * *