



US006776208B1

(12) **United States Patent**
Flynn et al.

(10) **Patent No.:** US 6,776,208 B1
(45) **Date of Patent:** Aug. 17, 2004

(54) **LABEL ASSEMBLY AND APPARATUS**

(76) Inventors: **Timothy J. Flynn**, 18 Caloosa Rd., Key Largo, FL (US) 33037; **Thomas E. Flynn**, 7305 Gleneagle Cir., Crystal Lake, IL (US) 60014; **Patrick J. Flynn**, 107 Jennifer St., Redlands, CA (US) 92373

(*) Notice: Subject to any disclaimer, the term of this patent is extended or adjusted under 35 U.S.C. 154(b) by 0 days.

5,925,200 A	7/1999	Grossman	
6,054,009 A	4/2000	Cote et al.	
6,273,167 B1	8/2001	Miller	
6,318,436 B1	11/2001	Hummell et al.	
6,321,811 B1	11/2001	Atkinson et al.	
6,347,654 B1	2/2002	Koch	
6,363,987 B1	4/2002	Koch	
6,405,777 B1	6/2002	Lebbad	
6,408,918 B1	6/2002	Hummell et al.	
6,431,238 B1	8/2002	Atkinson	
6,450,229 B1 *	9/2002	Koch	156/391
6,508,914 B1 *	1/2003	Schwaller et al.	156/391
6,514,588 B2 *	2/2003	Rosenbaum et al.	428/40.1
2001/0025689 A1	10/2001	Barnet	

(21) Appl. No.: 10/369,227

(22) Filed: Feb. 19, 2003

(51) Int. Cl.⁷ B65C 1/00; B65C 1/02

(52) U.S. Cl. 156/391; 156/540; 156/556; 156/DIG. 1; 156/DIG. 2

(58) Field of Search 156/391, 540, 156/556, DIG. 1, DIG. 2, 538; 206/308.1, 308.2

(56) **References Cited**

U.S. PATENT DOCUMENTS

465,588 A	12/1891	Wheeler	
1,500,698 A	7/1924	Wiehl	
1,821,916 A	9/1931	Acheson et al.	
4,084,015 A	4/1978	Patterson	
5,334,432 A	8/1994	Long	
5,715,934 A *	2/1998	Tobol et al.	206/232

* cited by examiner

Primary Examiner—Sue A. Purvis

(74) Attorney, Agent, or Firm—Pauley Petersen & Erickson

(57) **ABSTRACT**

A label assembly having a face sheet with a removable label portion is used in connection with an apparatus that includes a base that accommodates the label assembly in an aligned position. The label assembly further includes a back sheet having a removable first portion generally coextensive with the label portion of the face sheet so that when the first portion is removed from the label assembly, a remaining portion of the back sheet is attached to the label portion of the face sheet. An arm is connected with respect to the base to extend over the label assembly as the label portion is applied.

14 Claims, 13 Drawing Sheets

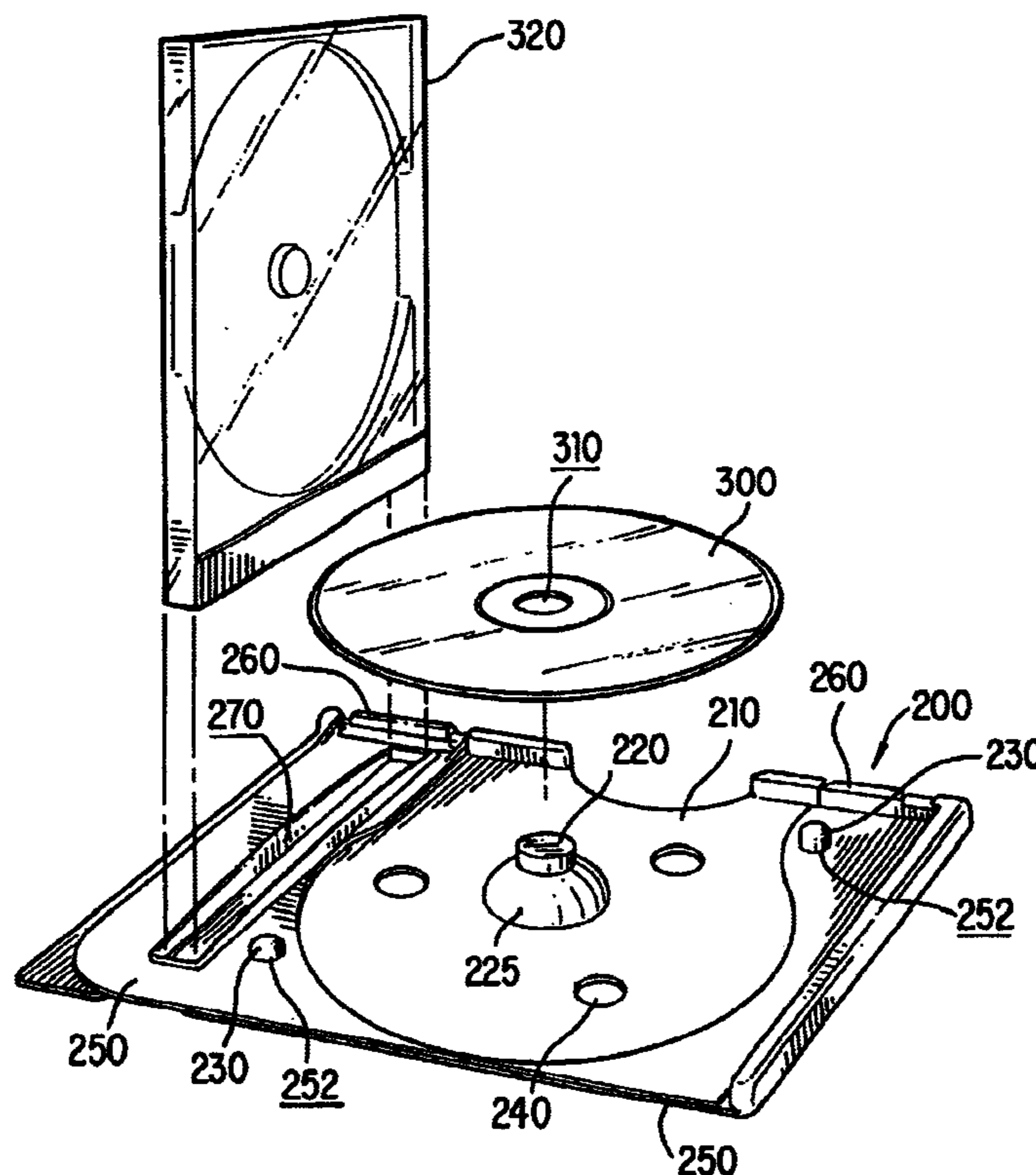

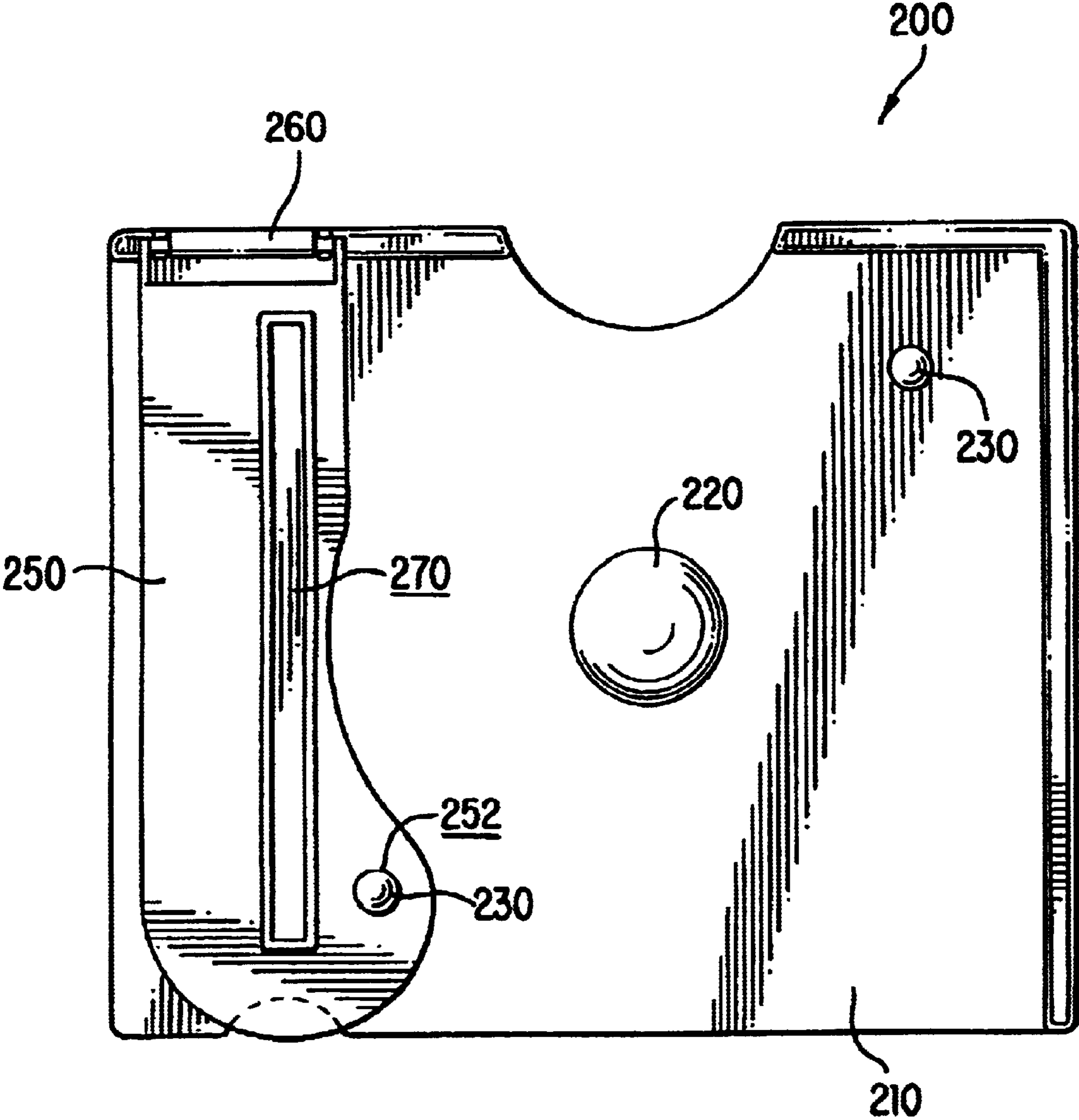

FIG. 1

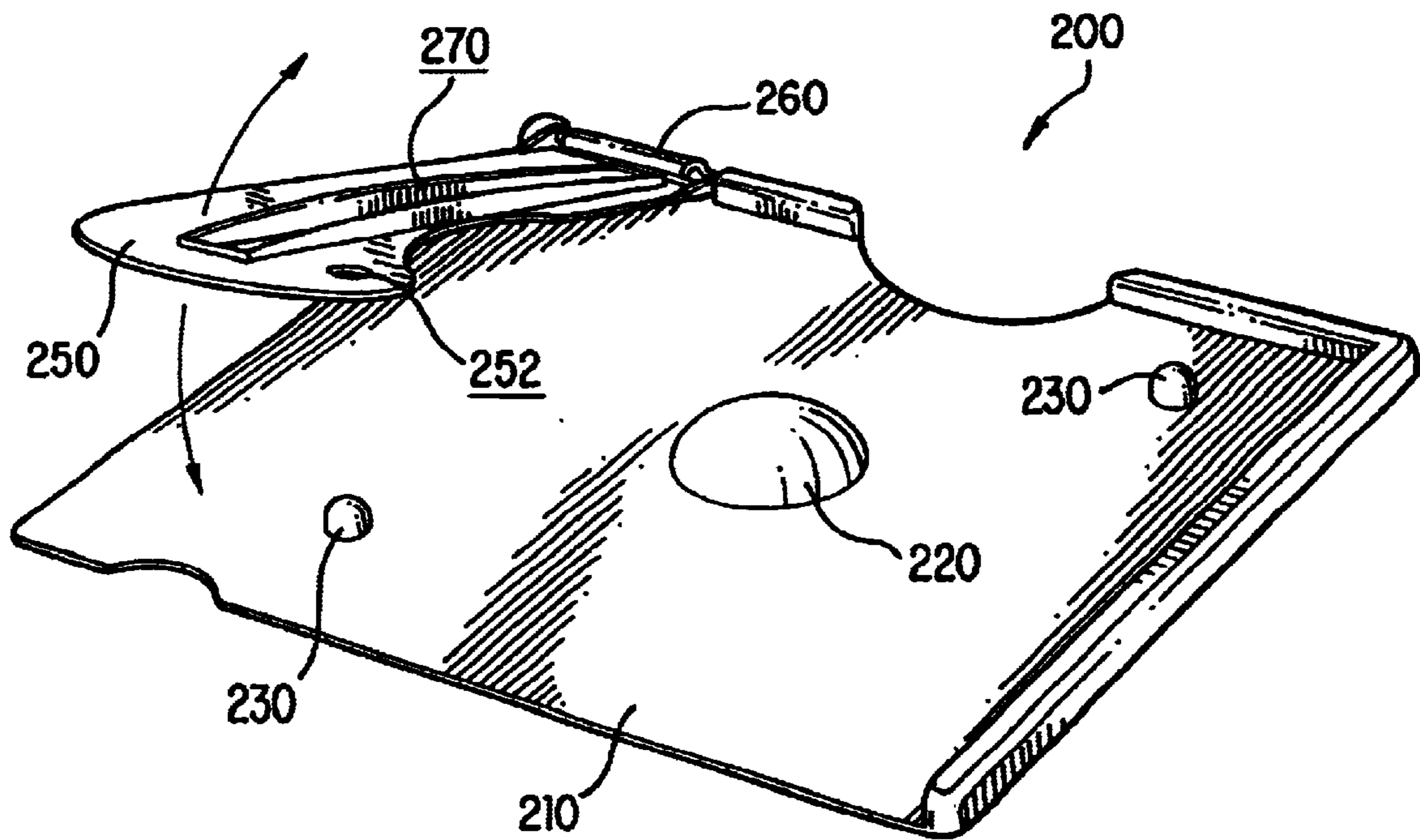

FIG. 2

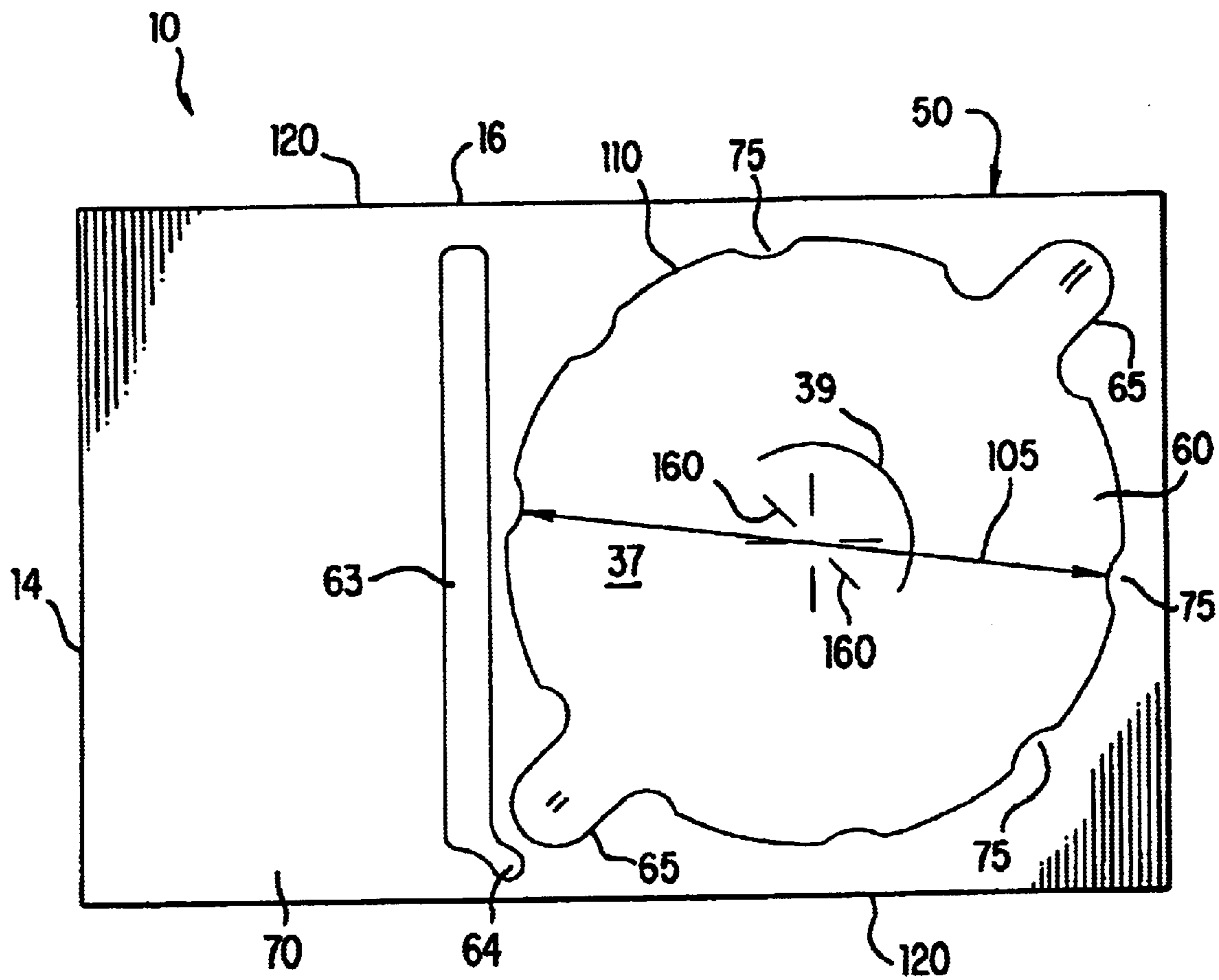
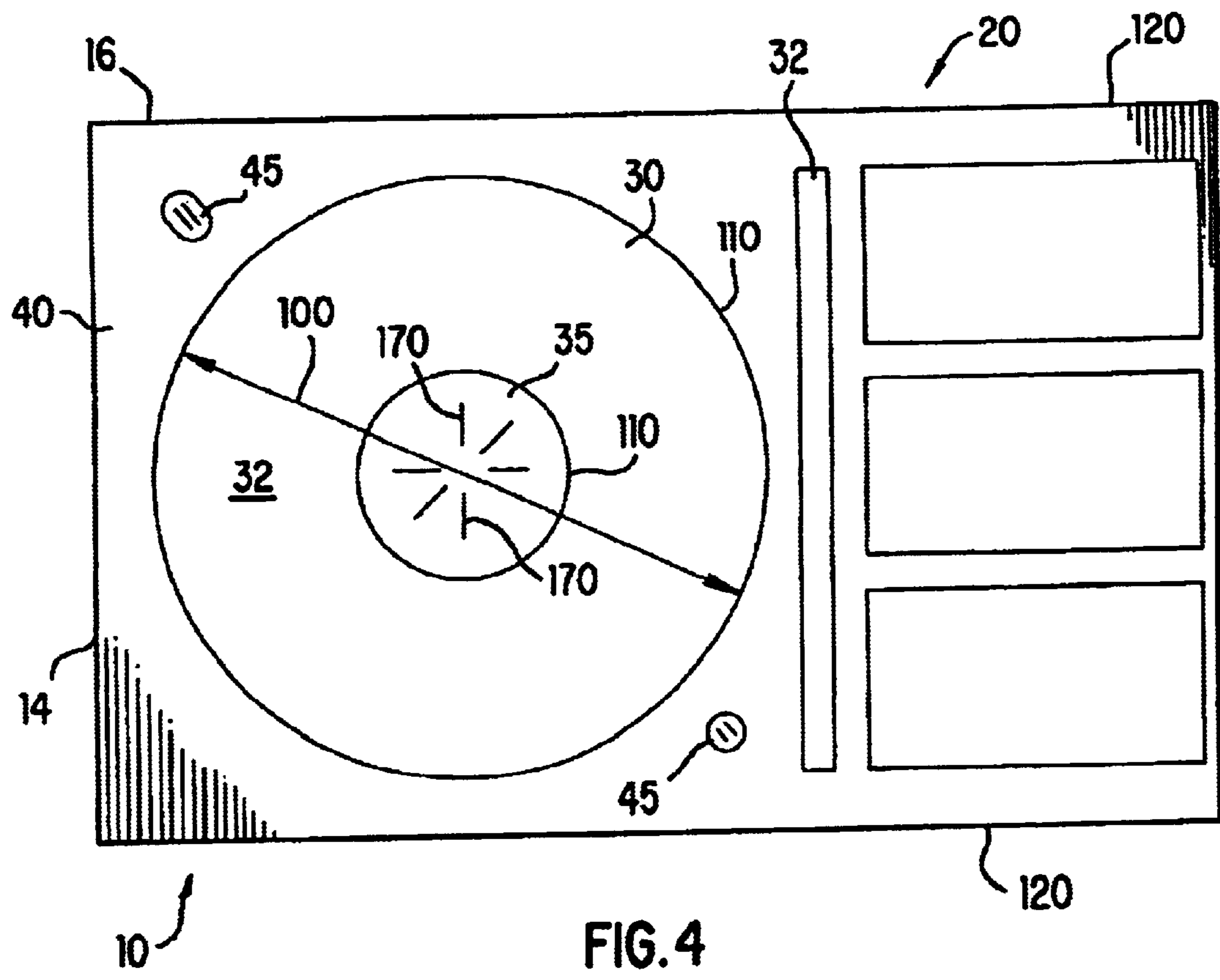

FIG. 3



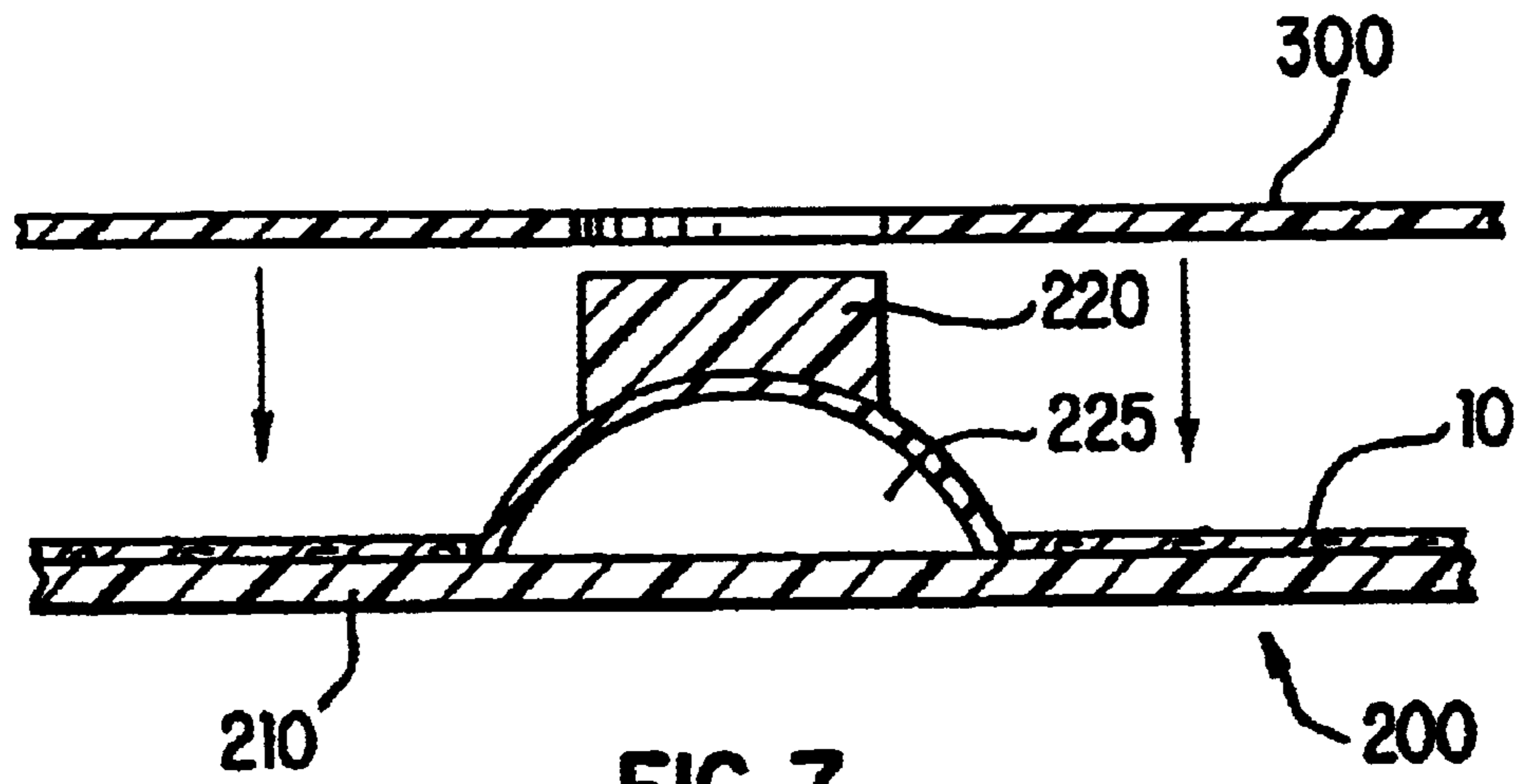

FIG. 7

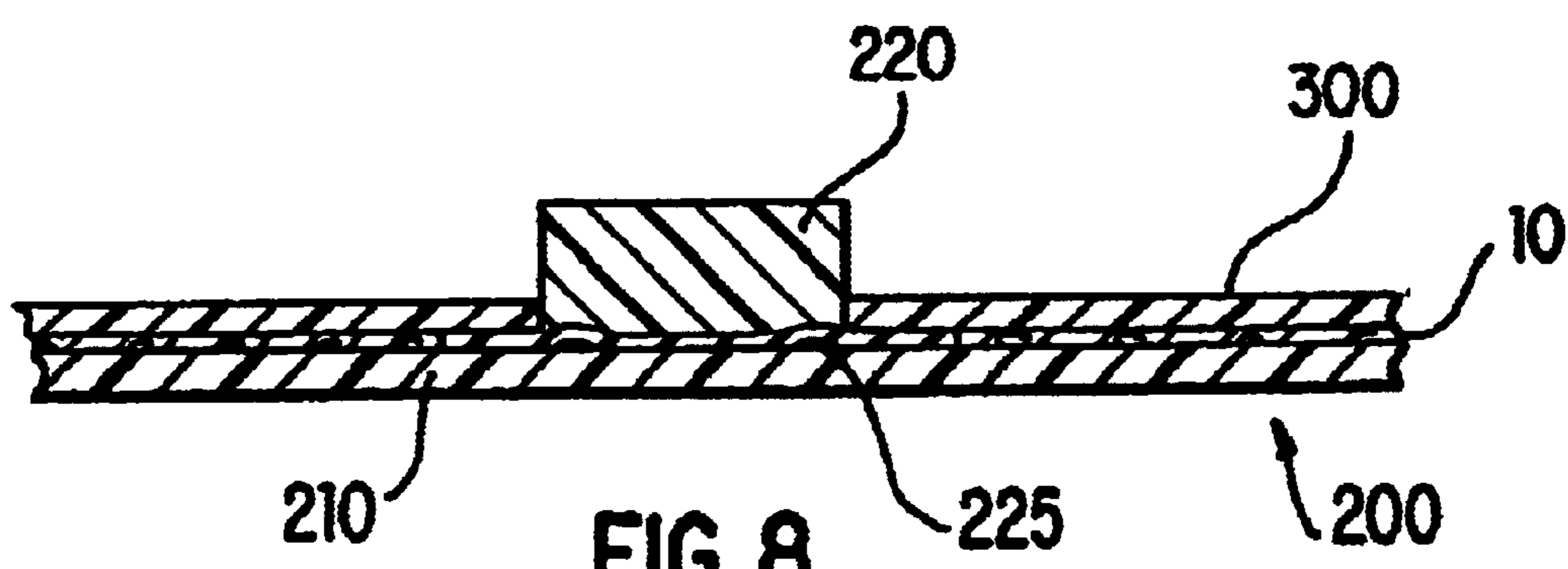

FIG. 8

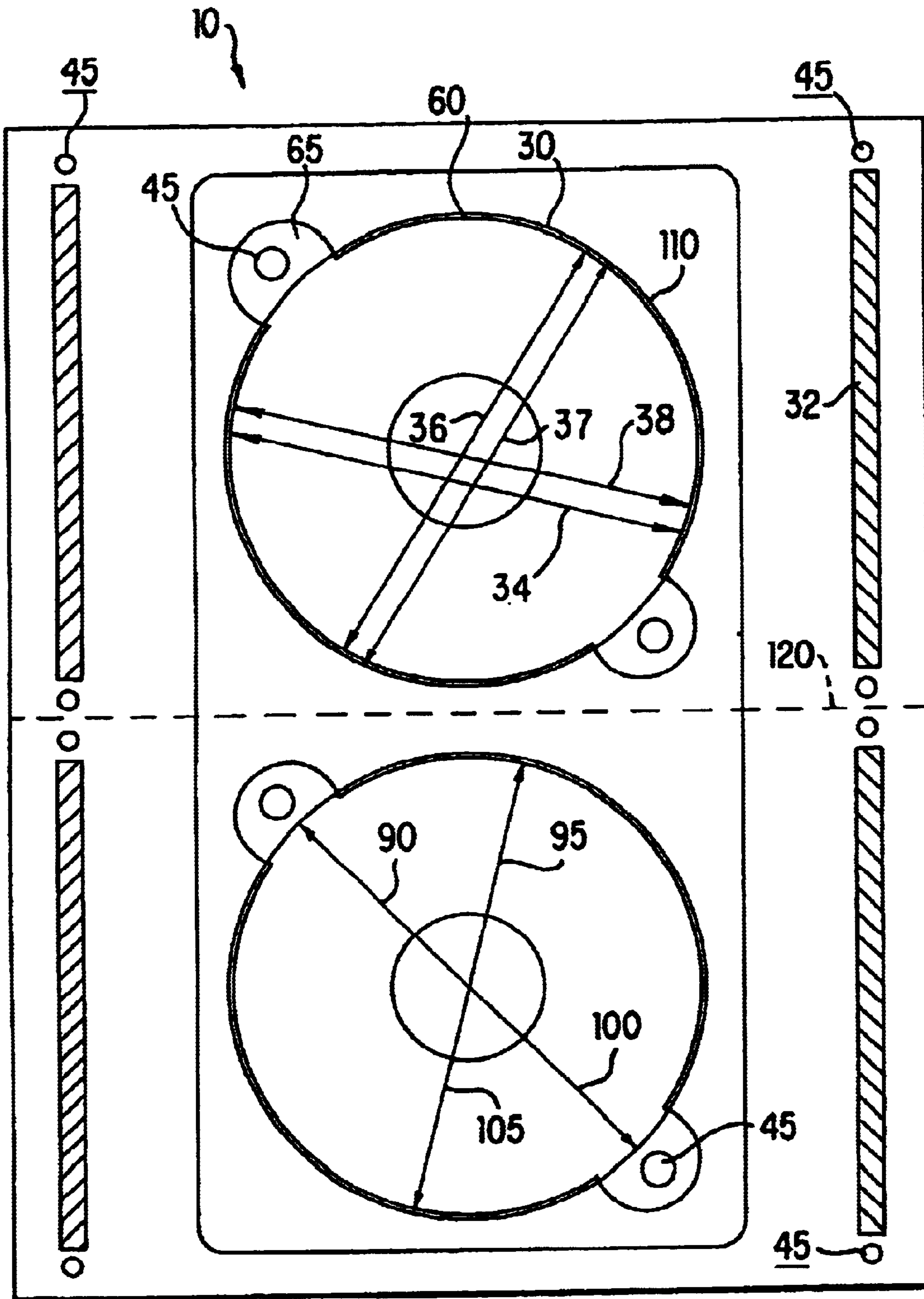

FIG. 9

10

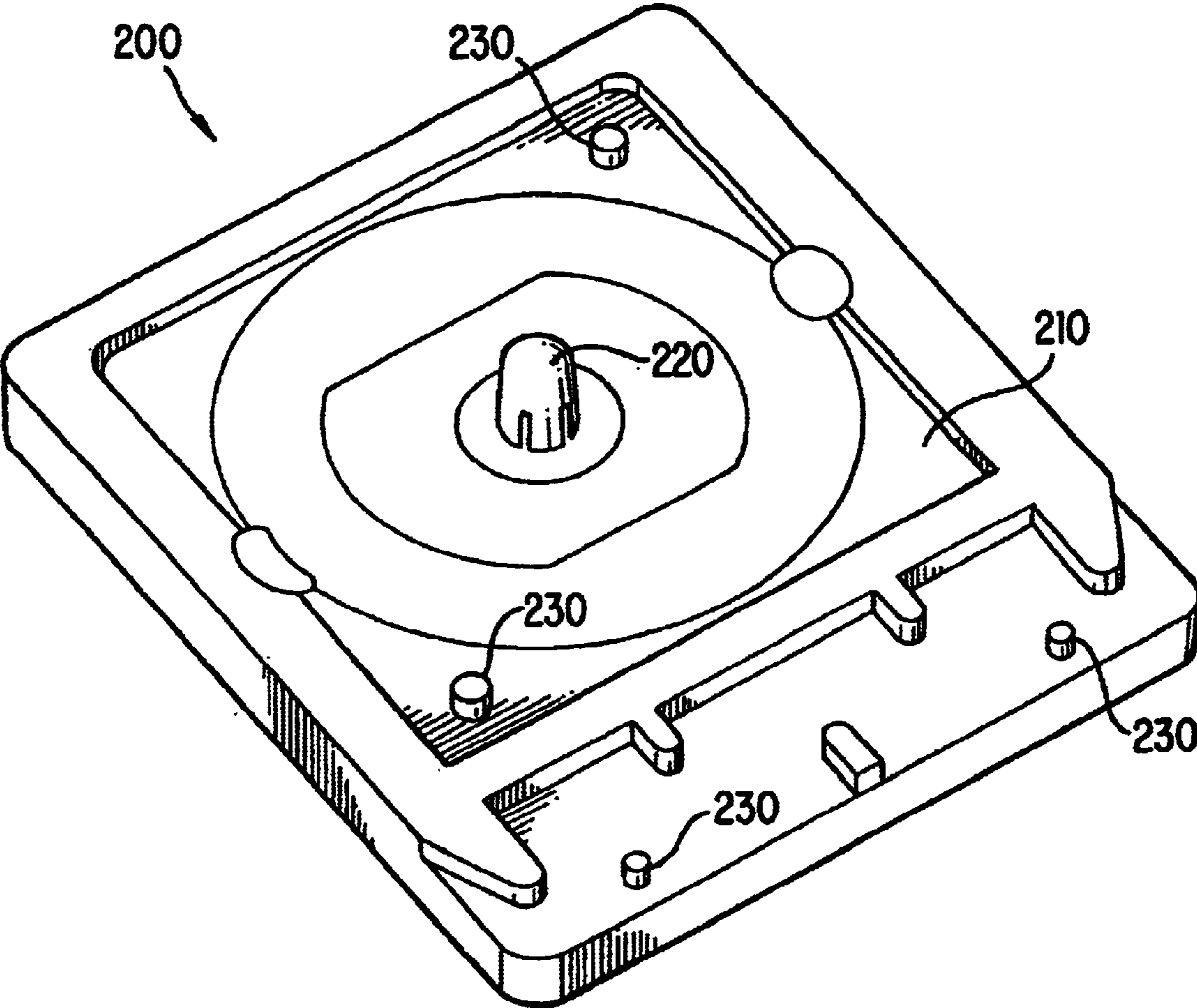

FIG. 10

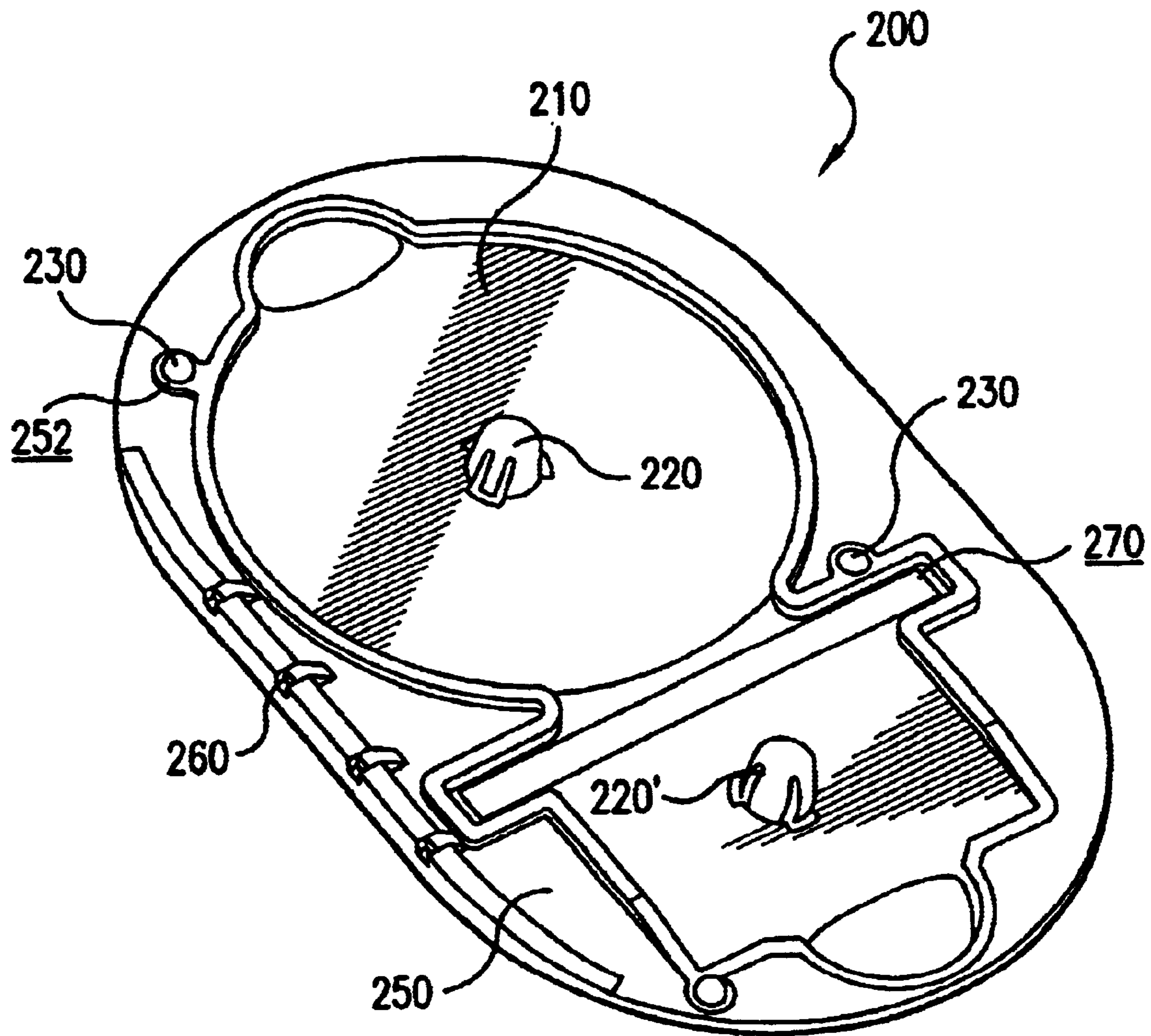
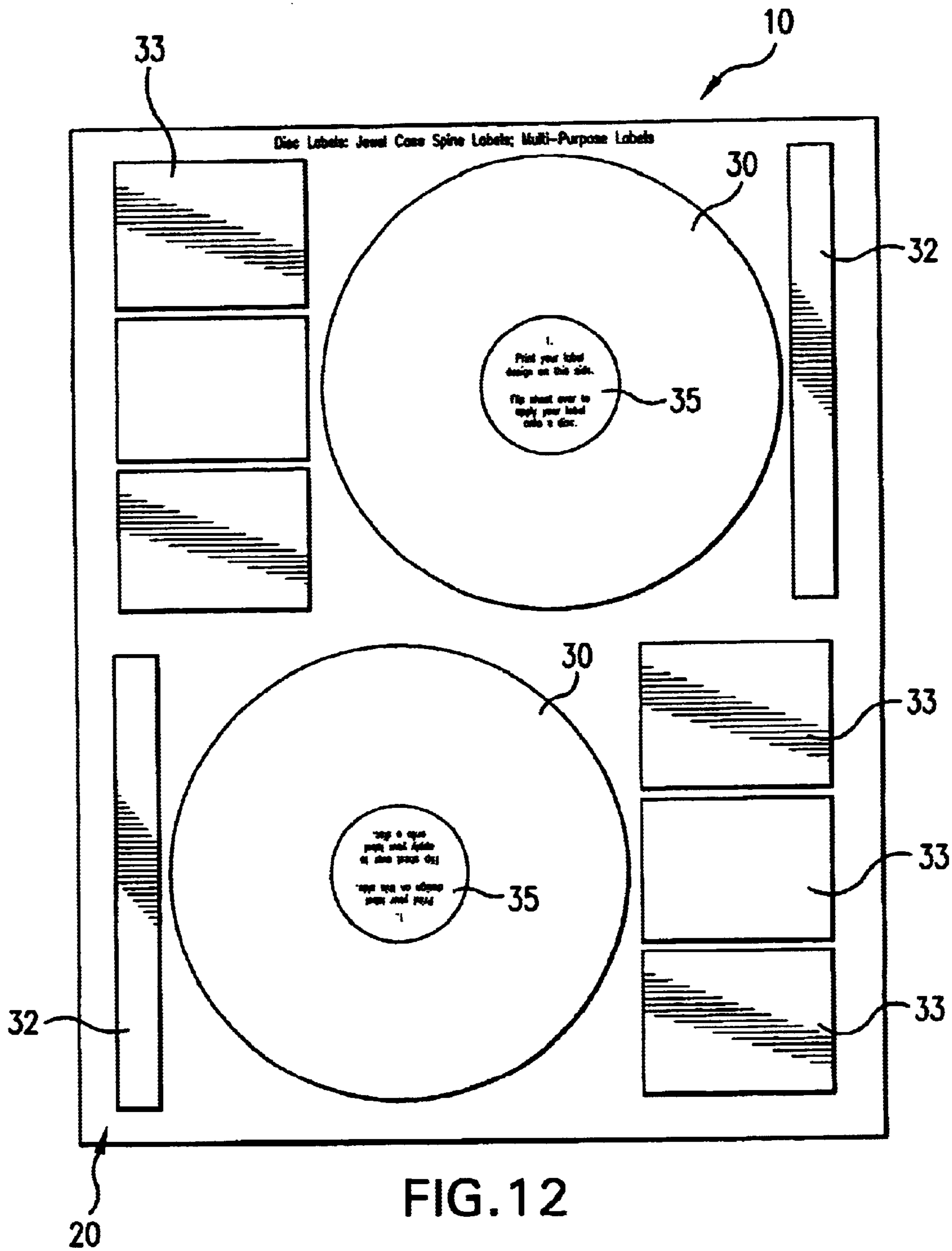
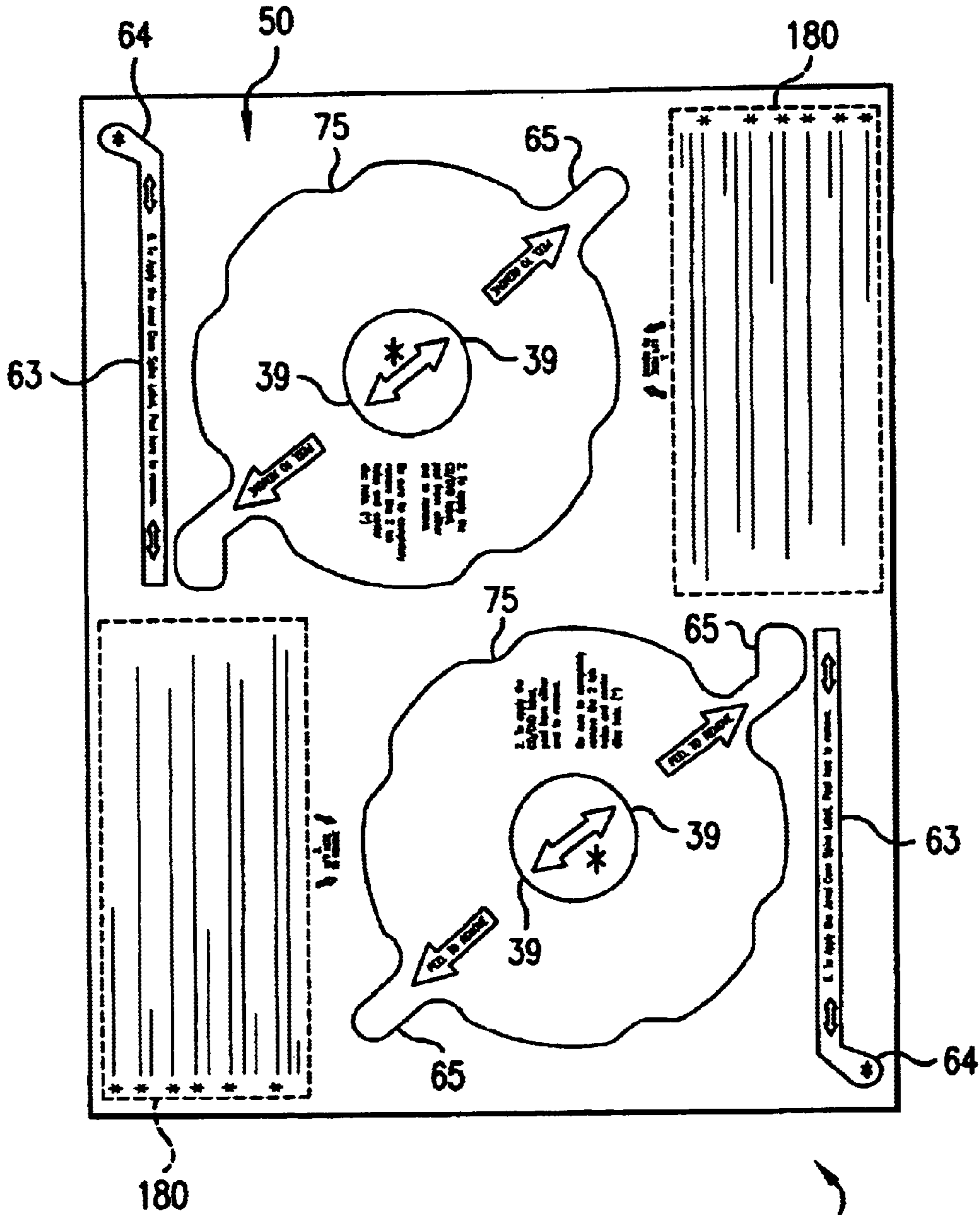

FIG. 11





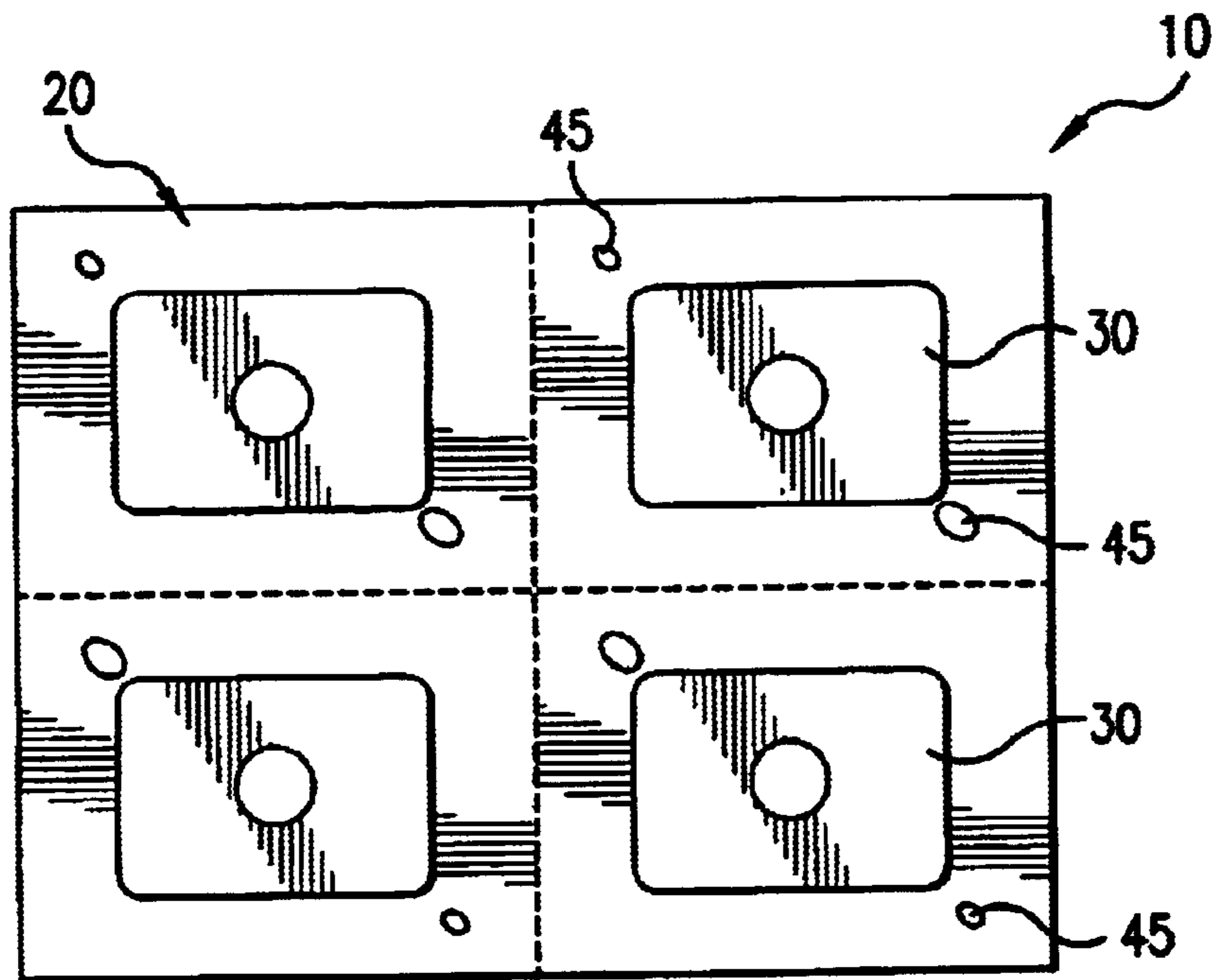

FIG. 14

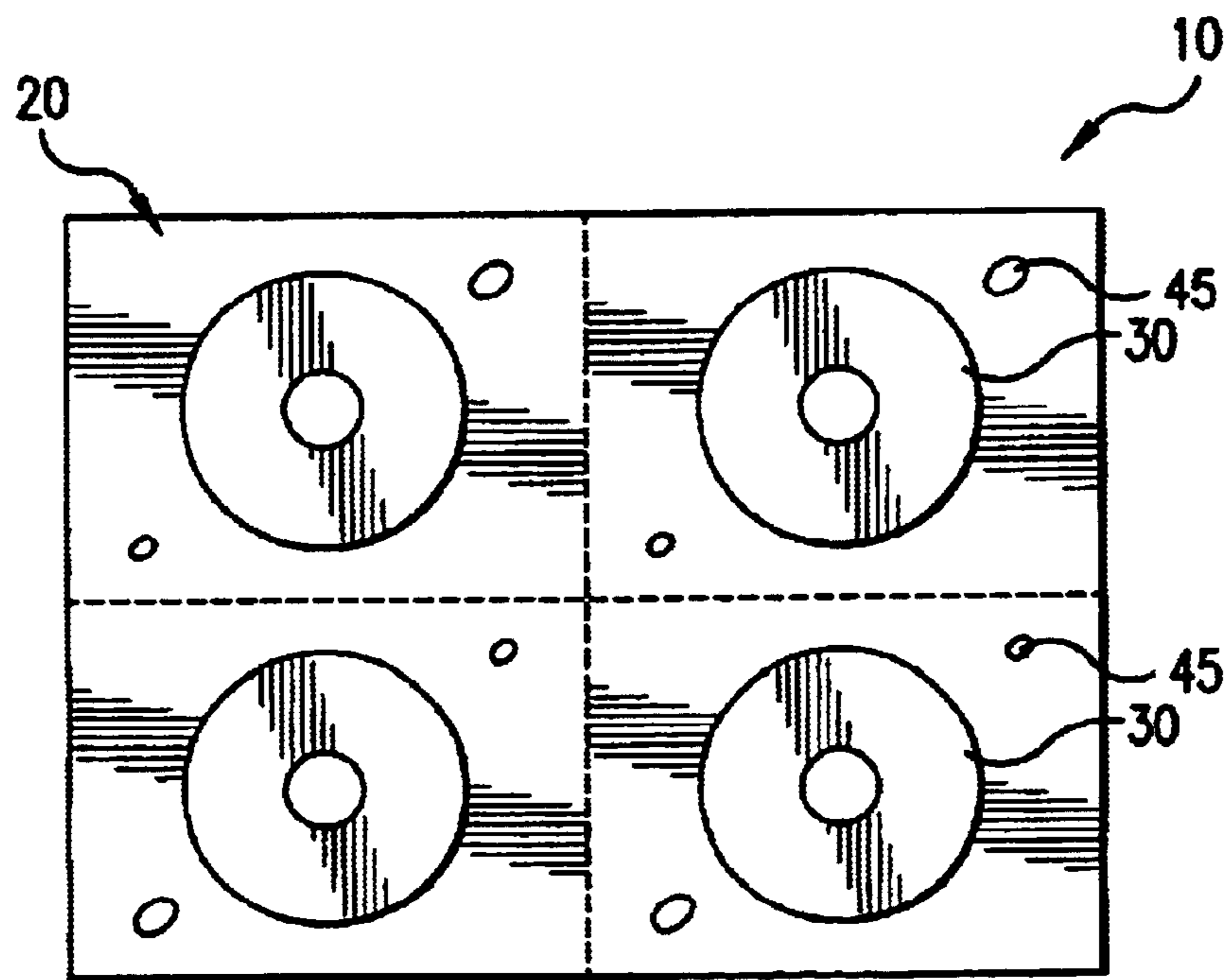

FIG. 15

LABEL ASSEMBLY AND APPARATUS**BACKGROUND OF THE INVENTION**

1. Field of the Invention

This invention is directed to a label assembly and apparatus for the positive, indexed application of labels to objects such as CDs.

2. Description of Related Art

Labels such as those described herein can be used in connection with a wide variety of items, particularly, compact discs (CDs), jewel cases and the like. It is desirable to have a label for adhering to items that will apply straight and direct to the object without misalignment, wrinkles, bubbles, folds or other errors inherent in the application of adhesive-backed labels to items.

In addition, labels improperly affixed to objects, such as CDs, with adhesive can harm the discs if a user attempts to remove and/or straighten the labels. More specifically, damage may be caused by pulling off some of the disc protective coating, metal and dye along with the label. In addition, when a traditional label is peeled from its backing, the traditional label includes an inherent curling that may manifest itself a period of time later by peeling away from the object. This peel memory is problematic with tradition peel and stick labels and particularly destructive when used in connection with CDs that require high-speed, balanced rotation for proper operation.

Accordingly, a need exists for a new and improved label or label assembly that provides means for labeling the CDs and related goods in an accurate and positive fashion. A further need exists for a label assembly that can be easily manufactured and assembled to form a label that may be applied in a consistent manner.

SUMMARY OF THE INVENTION

The present invention relates to a label assembly and an applicator apparatus, for use either independently or in tandem. The label assembly is of any suitable shape, and generally any suitable size that can be accepted by and fed through a printer, such as a laser printer or an ink jet printer. The label assembly preferably includes a face sheet and a back sheet with a layer of adhesive between. The adhesive is preferably applied to one side of the face sheet with an opposite side of the face sheet having a printable surface.

The label assembly according to a preferred embodiment of this invention further includes the face sheet having a label portion removable with respect to a carrier portion. The label portion is preferably pre-cut or shaped into a desired form for application in a desired manner, such as a CD.

The back sheet of the label assembly preferably includes a first portion that is removable with respect to a second portion. The back sheet preferably includes one side having a treated surface to facilitate removal of the back sheet relative to the face sheet. Therefore, at least one side of the back sheet preferably includes a smooth and/or waxy surface to ease separation from the adhesive side of the face sheet. The side opposite the treated surface of the back sheet may be a printable surface or any other suitable surface.

The first portion of the back sheet is preferably generally coextensive with the label portion of the face sheet. Likewise, the second portion of the back sheet is preferably generally coextensive with the carrier portion of the face sheet. When the first portion is removed from the label assembly, the second portion of the back sheet is attached to,

and supports, the label portion of the face sheet. In one embodiment of this invention, a circular label portion is retained following removal of a first portion that is generally circular and generally coextensive with label portion and includes two or more areas of overlap from the back sheet to the label portion. The areas of overlap may comprise two or more retainers that extend from the second portion and adhere to the label portion.

The label assembly may include one or more center holes and/or index holes that are removed as the first portion is removed. Such center holes and/or index holes may be used to align the label assembly onto a suitable applicator apparatus.

The apparatus for use in applying the label assembly may include a base and/or a center stem and/or one or more locating elements. The center stem of the apparatus may be mateable with the center hole of the label assembly. Similarly, the locating elements may be mateable with one or more index holes of the label assembly.

As a result of the configuration of the label assembly and/or the apparatus, the label portion is positioned so that the adhesive side of label portion faces upward from the base. When an object, such as a CD, is positioned on the apparatus and the label assembly, the label portion is transferred in a desired manner onto such object.

In operation, and as described above, the carrier portion of the label assembly remains on the apparatus following application of the label portion to the CD or other labeled object. Accordingly, the label portion is separated from the remaining label assembly leaving the carrier portion in position on the apparatus. As a result, a second labeling operation may be used to transfer one or more additional label portions onto an object using the same label assembly. The additional label portion may include a spine label for application to a CD jewel case and/or any other suitable labels including traditional peel and stick labels.

An arm may be used on the base to contact at least a portion of the label assembly, so that as the label portion is removed from the face sheet, the remainder of the face sheet and/or the carrier portion is retained and therefore the label portion separates cleanly from the carrier portion. The arm may further include a locating aperture that corresponds with a size and placement of a label portion when the arm is in a flush position relative to the base. As a result, an object may be inserted through the locating aperture in the arm to transfer the label portion of the face sheet onto the object.

It is therefore an object of the present invention to provide a label or label assembly that is suitable to be adhered to a compact disc (CD) or digital video disc (DVD).

It is a further object of the present invention to provide a label assembly that includes a label portion in a plane with the adhesive side facing upwards.

It is another object of the present invention to provide a label assembly that is indexable within an apparatus to provide uniform and repeatable application to an object.

It is yet another object of the present invention to provide a label assembly that includes index holes that mate with locating elements in an applicator apparatus.

It is also another object of the present invention to provide an apparatus for applying a label portion of a label assembly to an object that includes a moveable arm for maintaining a portion of the label assembly in a stationary position as the label portion is transferred to the object.

It is yet another object of the present invention to provide a label and/or label assembly suitable for labeling CDs and DVDs that does not adversely affect CDs and DVDs.

The foregoing and other features and advantages of the present invention will become further apparent from the following detailed description of the presently preferred embodiments, read in conjunction with the accompanying drawings. The detailed description and drawings are intended to illustrate the present invention rather than limit the scope of the present invention as defined by the appended claims and equivalents of the appended claims.

BRIEF DESCRIPTION OF THE DRAWINGS

The present invention can be better understood with reference to the following drawings. In the drawings, like reference numerals designate corresponding parts throughout the several views. Moreover, it should be noted that the drawings are not necessarily to scale, emphasis instead being placed upon clearly illustrating principles of the present invention.

FIG. 1 illustrates a top view of an apparatus for applying a label according to one preferred embodiment of this invention;

FIG. 2 illustrates a side perspective view of the apparatus shown in FIG. 1;

FIG. 3 illustrates a back sheet side view of a label assembly according to one preferred embodiment of this invention;

FIG. 4 illustrates a face sheet side view, opposite the view shown in FIG. 3, of the label assembly;

FIG. 5 illustrates a side perspective view of a label assembly as a first portion is removed from a label portion of the label assembly;

FIG. 6 illustrates an exploded side perspective view of an apparatus for applying a label without a label assembly in place according to one preferred embodiment of this invention;

FIG. 7 illustrates across-sectional side view of an apparatus for applying a label to a CD prior to application according to one preferred embodiment of this invention;

FIG. 8 illustrates a cross-sectional side view of the apparatus shown in FIG. 7 following application of the label to the CD;

FIG. 9 illustrates a top view of a label assembly according to one preferred embodiment of this invention;

FIG. 10 illustrates a top perspective view of an apparatus for applying a label to an object according to one preferred embodiment of this invention;

FIG. 11 illustrates a top perspective view of an apparatus for applying a label to an object according to one preferred embodiment of this invention;

FIG. 12 illustrates a top view of a label assembly according to one preferred embodiment of this invention;

FIG. 13 illustrates a bottom view of a label assembly of the label assembly shown in FIG. 12;

FIG. 14 illustrates a top view of a CD business card label assembly according to one preferred embodiment of this invention; and

FIG. 15 illustrates a top view of a mini CD label assembly according to one preferred embodiment of this invention.

DETAILED DESCRIPTION OF PREFERRED EMBODIMENTS

FIGS. 1–15 illustrate preferred embodiments of a label assembly 10 and apparatus 200 in accordance with the present invention. It is not necessary that apparatus 200

shown in FIGS. 1 and 2 be used with label assembly 10 shown in FIGS. 3–5 and vice versa; however, label assembly 10 and apparatus 200 may include features that are particularly useful when used together.

Referring generally to FIG. 3, label assembly 10 is of any suitable shape, and generally any suitable size that can be accepted by and fed through a printer, such as a laser printer or an ink jet printer. Common sizes of paper generally fed through printers are 8.5 inches by 5.5 inches, 8.5 inches by 11 inches, 8.263 inches by 11.688 inches (A4 size), and 8.5 inches by 14 inches. Label assembly 10 preferably comprises face sheet 20 and back sheet 30 with a layer of adhesive between.

Face sheet 20 is preferably but not necessarily constructed of any suitable paper, paper composite, non-metal and/or metal material that can be used as a label. Other suitable materials for constructing label sheet 20 include fabric, plastic, and metal foils. An adhesive coating is applied, in any suitable manner known to those skilled in the art, to one side of face sheet 20. Face sheet 20 preferably has a printable surface on a side opposite the adhesive side. The printable surface on face sheet 20 can be any of a variety of face materials used to make pressure sensitive, or self-adhesive labels. Such face materials may include, but are not limited to: smudgeproof stock, litho stock, cast coated stock, tag stock, fluorescent stock, foils, computer printable polyester, vinyl, satin cloth, Tyvek™ material, flexible plastic, book papers, photo quality papers and/or photo quality film. Furthermore, various portions of the face materials can be different colors, thereby resulting in different colored parts, such as the first portion 60 and/or label portion 30, as described more below.

As used throughout this specification and in the claims, the term “printable surface” relates to a surface of any type of matter upon which a person or machine can draw, print, color, paint, photocopy, write, emboss, or make any other type of mark or graphic. Laser printers, ink jet printers, impact printers, thermal transfer printers, direct thermal printers, typewriters, or any other suitable graphic printing devices are preferred but not necessary for use with printable surfaces according to this invention.

When manufacturing label assembly 10, face sheet 20 of material later to be cut into separate sheets each having label assembly 10. For example, label assembly 10 in FIG. 1 can be separated from adjacent label assemblies 10 connected to each respective lateral edge 14 and/or longitudinal edge 16. In order to provide a clean cut between adjacent label assemblies 10, taking into account manufacturing registration needs or a margin of error in spacing the cut, registration lines may extend between adjacent label assemblies 10. The registration lines are preferably but not necessarily substantially perpendicular to the resulting edge of an upline label assembly 10, and the resulting edge of a downline label assembly 10.

Label assembly 10 of the present invention is suitable for a wide number of uses. Prior to assembling, label assembly 10 can be fed into and run through a printer for labeling and/or decorating any portion. Label assembly 10 therefore includes at least one printable side for accepting printing, such as descriptive and/or decorative material.

Label assembly 10 according to a preferred embodiment of this invention includes face sheet 20 having label portion 30 removable with respect to carrier portion 40 of face sheet 20. Label portion 30 is preferably pre-cut or shaped into a desired form for application in a desired manner, such as a CD.

Back sheet **50** of label assembly preferably includes first portion **60** that is removable with respect to second portion **70**. Back sheet **50** preferably includes one side having a treated surface to facilitate removal of back sheet **50** relative to face sheet **20**. Therefore, at least one side of back sheet **50** preferably includes a smooth and/or waxy surface to ease separation from the adhesive side of face sheet **20**. The side opposite the treated surface of back sheet **50** may be a printable surface or any other suitable surface.

As shown in FIG. **5**, first portion **60** of back sheet **50** is preferably generally coextensive with label portion **30** of face sheet **20**. Likewise, second portion **70** of back sheet **50** is preferably generally coextensive with carrier portion **40** of face sheet **20**.

As briefly described above, a layer of an adhesive is preferably positioned between face sheet **20** and back sheet **50** so that the adhesive adheres to face sheet **20** exclusively or at least adheres to face sheet **20** more than to back sheet **50**. As a result of the above-described configuration, label assembly **10** includes face sheet **20** having a printable side and an opposite, adhesive side and a back sheet **50** including a separable side and an opposite side.

According to a preferred embodiment of this invention, when first portion **60** is removed from label assembly **10**, second portion **70** of back sheet **50** is attached to label portion **30** of face sheet **20**. Second portion **70** of back sheet **50** may be attached to label portion **30** entirely around a perimeter of label portion **30** or at one or more distinct points of label portion **30**. According to a preferred embodiment of this invention, back sheet **50** is "attached" to label portion **30** if movement of back sheet **50** results in complementary movement of label portion **30**.

According to one preferred embodiment of this invention, second portion **70** of back sheet **50** supports label portion **30** of face sheet **20**. Second portion **70** may support label portion **30** in a number of ways. According to one preferred embodiment of this invention, shown in FIG. **9**, first periphery **34** of label portion **30** is greater than second periphery **38** of first portion **60**. Alternatively or in addition, a first area **37** of label portion **30** may be greater than a second area **36** of first portion **60**. Likewise, a first maximum chord length **90** of label portion **30** may be greater than second maximum chord length **95** of first portion **60**.

As shown in FIG. **4**, label portion **30** may be circular, for instance to facilitate application to a CD, and includes first diameter **100**. First portion **60** is preferably correspondingly circular and has second diameter **105** wherein first diameter **100** is greater than second diameter **105**. Similarly, FIG. **5** shows circular label portion **30** and first portion **60** that is generally circular and generally coextensive with label portion **30** including two or more areas of overlap from back sheet **50** to label portion **30**. The areas of overlap may comprise two or more retainers **75** extending from second portion **70** and adhering to label portion **30**.

According to one preferred embodiment of this invention, label assembly **10** further includes at least one index tab **65** extending from a periphery of first portion **60**. Index tab **65** may be positioned on two sides of first portion **60** such as shown in FIG. **3**. Index tab **65** is preferably shaped in such a manner so as to facilitate peeling away of first portion **60**.

According to one preferred embodiment of this invention, particularly for use with labels for CDs and DVDs, center hole **35** is preferably positioned in a center area of label portion **30**. In addition, at least one index hole **45** may be positioned within carrier portion **40**. Index hole **45**, as shown in FIGS. **3-5** and **9**, may be positioned directly underneath

index tab **65** or in any other appropriate position on label assembly **10** including through back sheet **50** and/or face sheet **20**.

According to a preferred embodiment of this invention, when first portion **60** is peeled away or otherwise removed from label portion **30**, center hole **35** is opened and/or removed from label portion **30**. Likewise, when first portion **60**, including index tabs **65** is removed from label portion **30** and/or carrier portion **40**, index hole **45** is opened and/or removed from label portion **30** and/or carrier portion **40**.

Center hole **35**, index hole **45** and/or any other cutout segment of face sheet **20** may be separated from a remaining portion of face sheet **20** using an arrangement of cuts such as shown in FIG. **3**. As shown, one or more first cuts **160** may extend downwardly into first portion **60** and one or more second cuts **170** may extend upwardly into label portion **30** resulting in one or more alternating cuts extending in each direction through label assembly **10**. As a result, first cut **160** and second cut **170** join a segment, section and/or cutout of label portion **30** and/or carrier portion **40** to the treated (removeable) side of first portion **60**.

Alternatively, or in addition, and as shown in FIGS. **3-5**, center hole **35** may be opened upon removal of first portion **60** using die cut **39** extending partially along a perimeter of center hole **35** through both face sheet **20** and back sheet **50**. Die cut **39** is preferably generally arcuate and positioned along a side of center hole **39** that corresponds with a side of first portion **60** that is removed first, as particularly shown in FIG. **5**. According to an embodiment of die cut **39** having an arcuate shape, the arc preferably extends between approximately 1° and 180° along center hole **35** and more preferably extends between approximately 5° and 90° along the center hole.

Alternatively, or in addition, center hole **35** may be opened upon removal of first portion **60** using an offset center hole **35** relative to a corresponding die cut **39** in first portion **60** alone.

As described above, first portion **60** is separable from label assembly **10** across one or more lines of separation **110** that are positioned in back sheet **50** and each extend from a boundary line between first portion **60** and second portion **70** and inward into back sheet **50**. As a result of lines of separation **110**, such die cuts, first portion **60** is separable from second portion **70**. In certain instances, lines of separation **110** may result in some adherence between adjacent first portion **60** and second portion **70** because of interference between edges in addition to slight seepage of adhesive within lines of separation **110**.

According to one particular embodiment of this invention, label assembly **10** is used for a CD or DVD and includes face sheet **20** having a circular label portion **30** that is removable with respect to carrier portion **40** of face sheet **20** and then applied to the CD. Back sheet **50** includes a generally circular first portion **60** removable with respect to second portion **70** of back sheet **50**. Because first portion **60** of back sheet **50** is generally, but not truly, coextensive with label portion **30** of face sheet **20** includes a smaller surface area than label portion **30** of face sheet **20**, label portion **30** is retained by second portion **70** of back sheet **50**. Further, because the adhesive layer of label portion **30** is exposed, a CD may be placed on top of label assembly **10** thereby affixing label portion **30** to CD.

Because of the arrangement of label assembly described above and the apparatus described below, label portion **30** may be perfectly round to correspond with the diameters of a CD or may be decorative, such as including a fanciful

flower or buzzsaw outline for unique applications. The shape of label portion **30** is not limited by the manner in which it is applied according to this invention because label portion **30** remains attached to carrier portion **40** until the object is applied and therefore is not subject to bending, curling, wrinkles and/or other imperfections which a fanciful outline may otherwise include. In other words, when a traditional label is removed from a back sheet and then applied to another object, the traditional label curls as it is removed and then tends to wrinkle or bend as it is applied. In contrast, label assembly **10** according to this invention, maintains label portion **30** in a flat and fixed position, the object to be labeled may be uniformly applied to the label rather than vice versa.

According to a preferred embodiment of this invention, label assembly **10** may include at least one additional label portion, such as additional portion **63**, removable from back sheet **50** for use elsewhere in the particular application, for instance, for placement on a jewel case of the CD. Additional portion **63** may be arranged in the same way as label portion **30** or may otherwise be a traditional label that is removed from back sheet **50** for subsequent placement on an object.

FIGS. **1**, **2**, **6–8** and **10** illustrate preferred embodiments of apparatus **200** for use in applying label assembly **10** as generally described above and in accordance with the present invention. More particularly, FIGS. **1**, **2**, **6–8** and **10** show apparatus **200** according to various preferred embodiments of this invention, particularly suitable for applying a label to a CD, DVD or business-card CD. Apparatus **200** preferably includes base **210** and which is molded or otherwise formed of plastic, metal, wood or any other suitable strong, durable and generally rigid material known to those having ordinary skill in the art. Depending upon the desired application, base **210** may include a recessed and/or otherwise contoured portion for accommodating a particular object, such as a CD.

According to a preferred embodiment of this invention, for use with labeling CDs, base **210** includes center stem **220** extending from a center area of the contoured portion of base **210**. Center stem **220** is preferably sized to fit through a CD aperture **310** and may include one or more particular features, such as described below, that positively maintain CD **300** in position and/or permit CD **300** to be lowered onto base in a uniform fashion.

Apparatus **200** preferably further includes one or more locating elements **230** extending from base **210**. FIGS. **1** and **2** shows two locating elements **230** extending from base **210**, however, depending upon the application, base **210** may include one, two, three or many more locating elements **230**, such as the four locating elements **230** shown in FIG. **10**. Locating elements **230** are preferably mateable with index holes **45** and used to position label assembly **10** in a desired position on apparatus **200**.

Label assembly **10** is preferably positioned on base **210**, particularly within the contoured portion of base **210**. As a result, label portion **30** of label assembly **10** is positioned so that the adhesive side of label portion **30** faces upward from base **210**. As a result, when an object, such as CD **300**, is positioned on apparatus **200** and label assembly **10**, label portion **30** is transferred in a desired manner to such object.

Apparatus **200** as described can therefore accommodate label assembly **10** having index hole **45** to mate with locating element **230** and/or center hole **35** to mate with center stem **220**. Therefore, when label assembly **10** is in an indexed position within apparatus **200**, locating element **230**

extends through index hole **45** and center stem **220** extends through center hole **35**.

In operation, and as described above, carrier portion **40** remains on apparatus **200** following application of label portion **30** to the CD or other labeled object. Accordingly, label portion **30** is separated from the remaining label assembly **10**, leaving carrier portion **40** in position on apparatus **200**. As a result, a second labeling operation may be used to transfer one or more additional label portions onto an object using the same label assembly **10**, such as described in more detail below.

According to a preferred embodiment of this invention, label portion **30** can be used as a label for CD **300** shown in FIG. **6**. More particularly, the label portion **30** is die-cut, perforated, micro-perforated, or otherwise cut to form tearable line of separation which can be used to remove label portion **30** in any suitable shape, such as a circle, preferably of a slightly smaller surface area than a surface area of a CD **300**.

In particular, a method for labeling a CD according to this invention, uses a label sheet (or label assembly **10**) with back sheet **50** and face sheet **20** wherein face sheet **20** includes an adhesive side and a printable side. The user first removes first portion **60** of back sheet **50** from face sheet **20**. As a result, label portion **30** of face sheet **20** is exposed so that the adhesive side faces upwards. The label sheet is then placed into an indexed position on apparatus **200**. Finally, CD **300** is placed onto apparatus **200** resulting in label portion **30** transferring onto CD **300** in an aligned manner free of creases, bubbles or other irregularities.

As described above, the label sheet may be indexed on apparatus **200** using at least one index hole **45** corresponding with locating element **230** on apparatus **200**. Alternatively, or in addition to index hole **45**, the label sheet may be indexed on apparatus **200** using center hole **35** corresponding with center stem **220** of apparatus. Alternatively, or in addition to index hole **45** and/or center hole **35**, the label sheet may be indexed on apparatus **200** using a contoured or otherwise uniquely defined surface on base **210**.

As described above, prior to application of label portion **30** to CD or other object, label portion **30** is maintained within face sheet **20** with two or more retainers **75** positioned in back sheet **50** around a perimeter of label portion **30**. Therefore, label portion **30** of face sheet **20** is exposed so that the adhesive side faces upwards and label assembly **10** is positioned in an indexed position on apparatus **200**.

According to one preferred embodiment of this invention, a CD **300** or other object is placed onto apparatus **200**, preferably so that center stem **220** extends through CD aperture **310**. As a result of placing CD **300** on label portion **30** in this manner, and preferably applying light pressure, label portion **30** of face sheet **20** is transferred onto CD **300**. According to one preferred embodiment of this invention, shown in FIGS. **6–8**, center stem **220** may further include compressible element **225**, such as a compressible dome, positioned beneath center stem **220** wherein compressible element **225** is compressible following application of a downward force. Compressible element **225** may be constructed of an elastic polymer, similar to that used underneath computer keyboard keys so that when a gentle downward force is applied, compressible element **225** compresses uniformly. As a result, center stem **225** which is mated with CD aperture **310**, is lowered onto base **210** and thereby CD **300** is lowered onto label portion **30** in a generally uniform manner following application of pressure.

Following application of the object to label portion **30**, the object may be removed using one or more finger apertures

240 positioned through base **210**. In operation, the object, such as CD **300**, may be applied to label portion **30** and still remain somewhat affixed to apparatus **200** through carrier portion **40** of label assembly **10**. By extending fingers through finger apertures **240**, CD **300** is separated from carrier portion **40** and expelled from base **210** with label portion **30** attached.

In addition to center stem **220** mating with center hole **35**, label assembly **10** may be further indexed on apparatus **200** using at least one index hole **45** in label assembly **10** and at least one corresponding locating element **230** in apparatus **200**.

According to one preferred embodiment of this invention, apparatus **200** includes arm **250** that is moveable into contact with at least a portion of label assembly **10** prior to transferring label portion **30** of face sheet **20** onto the object such as a CD **300** and/or CD jewel case **320**. Arm **250** is preferably moveable between a position generally flush with base **210** and a position away from base **210**. As shown in FIGS. **1** and **2**, arm **250** may swing from hinge **260** along a side of base **210** between a position on or generally flush with base **210** and a position back away from base **210**.

Arm **250** may be positively mated with base **210** when in a position flush with base **210** by aligning locating element **230** of base **210** with arm aperture **252** of arm **250**. As a result, locating element **230** may extend first through label assembly **10** and then, when arm **250** is positioned in contact with base **210**, locating element **230** extends through arm aperture **252**, such as shown in FIG. **1**.

Arm **250** preferably swings into contact with at least a portion of label assembly **10**, so that as label portion **30** is removed from face sheet **20**, the remainder of face sheet **20**, or carrier portion **40**, is retained and therefore label portion **30** cleanly separates from carrier portion **40** of the remaining label assembly **10**. FIG. **6** shows one preferred embodiment of arm **250** that surrounds a central portion of base **210** on three sides so as to retain label assembly **10** as one or more label portions **30** are removed.

In addition, at least one additional label portion may be indexed on apparatus **200** for placement elsewhere, such as a CD jewel case **320**. Like the method described above for label portion, an additional portion **63** of back sheet **50** may be removed from face sheet **20** to expose second label portion **32** of face sheet **20**. Second label portion **32** may be, for instance, a spine label for a spine of CD jewel case **320**, such as shown in FIG. **6**. Like label portion **30** described above, second label portion **32** is drawn from label assembly **10** having back sheet **50** and a face sheet **20**, wherein additional portion **63** of back sheet **50** is removable from face sheet **20** to expose second label portion **32**, such as a spine label. Additional portion **63** preferably includes a gate surface area than second label portion **32**. At least one pull tab **64** may extend from a periphery of additional portion **63** to facilitate removal, both visually and physically.

According to one preferred embodiment of this invention, arm **250** may further include locating aperture **270** that corresponds with a size and placement of second label portion **32** when arm **250** is in a flush position relative to base **210**. As a result, an object may be inserted through locating aperture **270** in arm **250** to transfer second label portion **32** of face sheet **20** onto the object. For instance, an edge of CD jewel case **320** may be inserted through locating aperture **270** in arm **250** to transfer second label portion **32** (a spine label) onto CD jewel case **320**.

According to one preferred embodiment of this invention, two or more label assemblies **10** may be joined end-to-end

along a longitudinal boundary **120**. Preferably, each adjacent label assembly **10** is rotated 180° relative to each other to facilitate application of each label portion **30** to a CD **300**. As such, each label portion **30** of each adjacent label assembly **10** may be printed and then a first label assembly **10** may be inserted into apparatus **200** to apply label portion **30** followed by rotating the pair of label assemblies 180° and then inserting the second label assembly **10** into apparatus to apply label portion **30** to a second CD **300**.

FIG. **11** illustrate an additional preferred embodiment of apparatus **200** for use in applying label assembly **10** as generally described above and in accordance with the present invention. Apparatus **200** shown in FIG. **11** is particularly suitable for applying a label to a CD, DVD, mini CD or business-card CD. Apparatus **200** preferably includes base **210** and which is molded or otherwise formed of plastic or any other suitable strong, durable and generally rigid material known to those having ordinary skill in the art. Depending upon the desired application, base **210** may include a recessed and/or otherwise contoured portion for accommodating a particular object, such as a CD or a business-card CD. Base **210** may further include a recessed and/or otherwise contoured portion for accommodating a spine of jewel case **320**.

According to a preferred embodiment of this invention, for use with labeling CDs, base **210** includes center stem **220** extending from a center area of the contoured portion of base **210**. Center stem **220** is preferably sized to fit through a CD aperture **310** and may include one or more particular features, such as described above, that positively maintain CD **300** in position and/or permit CD **300** to be lowered onto base in a uniform fashion. As shown, base **210** may additionally include second center stem **220'** for accommodating business-card CDs and/or mini CDs.

Apparatus **200** shown in FIG. **11** further includes three locating elements **230** extending from base **210**, one on a side of the recess for the CD and one on a side of the recess for the business-card CD/mini CD, with a common locating element **230** between them. Locating elements **230** are preferably mateable with index holes **45** and used to position label assembly **10** in a desired position on apparatus **200**.

In addition, apparatus **200** shown in FIG. **11** includes arm **250** that is hinged to base **210** along hinge **260**. Arm **250** preferably overlaps an edge of CD **300**, mini CD and/or business-card CD prior to application of label portion **30**. Arm **250** shown in FIG. **11** additionally includes a locating aperture **270** for placement and indexing a spine of jewel case **320** for application of second label portion **32** to the spine of jewel case **320**.

FIGS. **12** and **13** show label assembly **10** according to another preferred embodiment of this invention. As shown, face sheet **20** of label assembly **10**, shown in FIG. **12**, includes label portion **30**, second label portion **32** and additional label portions **33** for printing and application as needed. On a reverse side of face sheet **20** is back sheet **50**, shown in FIG. **13**. Back sheet **50** preferably includes a corresponding first portion **60** for removing to expose an adhesive side of label portion **30**. Also, additional portion **63**, corresponding with second label portion **32**, is removable to facilitate application of second label portion **32** to spine of jewel case **320**.

As shown, back sheet **50** preferably includes printed detailed application instructions **180**. The detailed application instructions **180** on back sheet **50** may include: "1. Print your label design on opposite side. 2. Peel and remove the backing sheet from the label (as shown), removing the 2 tab

11

holes and the center disc hole. 3. Align tab holes and lower the sheet onto the applicator, printed side down (sticky side up.) 4. Lower the applicator lid over the label. Firmly press the disc face down onto the label. Apply even pressure to ensure proper labeling. 5. Lift and remove the disc from the applicator by gripping the disc edge (as shown) and pulling the labeled disc up and away from the backing sheet. Smooth down the label surface to ensure 100% adhesion. 6. To apply the Jewel Case Spine Label, peel and remove the spine label backing strip (as shown.) Firmly press the end of the jewel case onto the label using the applicator slot as a guide. Lift the jewel case to finish.” Although the preceding language differs slightly from the nomenclature used herein, similar instructions may be used with nomenclature consistent with that used herein.

FIGS. 14 and 15 show face sheet 20 side of label assembly 10 for application to business-card CDs (FIG. 14) and for application to mini CDs (FIG. 15). Such label assemblies 10 operate in a consistent fashion to those described above and may be combined in separable sheets of two, three and four or more. Such separable sheets may be printed and then separated along perforations or other lines of weakness to facilitate application using apparatus 200 such as those described herein. In addition, label assembly 10 may include combinations of label portions 30 for application to regular CDs, business-card CDs and/or mini CDs. Therefore, a single label assembly 10 may include label portion 30 for a regular CD, label portion 30 for business-card CD and/or label portion 30 for mini CD.

While in the foregoing specification this invention has been described in relation to certain preferred embodiments thereof, and many details have been set forth for purpose of illustration, it will become apparent to those skilled in the art that the invention is susceptible to additional embodiments and that certain of the details described herein can be varied considerably without departing from the basic principles of the invention. Therefore, to particularly point out and distinctly claim the subject matter regarded as the invention, the following claims conclude the specification.

We claim:

1. An apparatus for applying a spine label on a CD jewel case comprising:

a base;

a label assembly indexed on the base, the label assembly having a spine label with an adhesive side facing upward; and

an arm positioned over the label assembly, the arm retaining the label assembly against the base.

2. The apparatus of claim 1 wherein the arm further comprises an aperture, the aperture sized to fit an edge of the CD jewel case.

3. The apparatus of claim 1, wherein the label assembly further comprises back sheet and a face sheet, wherein a portion of the back sheet is removable from the face sheet to expose the spine label, the portion having a greater surface area than the spine label.

12

4. The apparatus of claim 3, further comprising at least one pull tab extending from a periphery of the portion.

5. The apparatus of claim 1, further comprising at least one index hole positioned within the label assembly, the index hole for aligning the label assembly on the base.

6. A label assembly and apparatus comprising:

a base that accommodates the label assembly in an aligned position;

a face sheet having a removable label portion;

a layer of adhesive adhered to the face sheet;

a back sheet having a removable first portion generally coextensive with the label portion of the face sheet so that when the first portion is removed from the label assembly, a remaining portion of the back sheet is attached to the label portion of the face sheet, the layer of adhesive on the label portion facing upward from the base; and

an arm of the base that extends over the label assembly, the arm having an aperture that surrounds the label portion, the aperture sized to fit a CD.

7. The label assembly according to claim 6, further comprising at least one index hole positioned within the face sheet, the index hole opening upon removal of the first portion.

8. The label assembly according to claim 6 further comprising:

an additional aperture positioned within the arm, the additional aperture sized to fit an edge of a CD jewel case.

9. The label assembly according to claim 6 wherein the arm is moveable between a position flush with the label assembly and a position away from the base.

10. An apparatus for applying a spine label on a CD jewel case comprising:

a base;

a label assembly indexed on the base, the label assembly having a spine label with an adhesive side facing upward; and

an aperture positioned over the label assembly, the aperture sized to fit an edge of the CD jewel case.

11. The apparatus of claim 10, wherein the label assembly further comprises back sheet and a face sheet, wherein a portion of the back sheet is removable from the face sheet to expose the spine label, the portion having a greater surface area than the spine label.

12. The apparatus of claim 11, further comprising at least one pull tab extending from a periphery of the portion.

13. The apparatus of claim 10, further comprising at least one index hole positioned within the label assembly, the index hole for aligning the label assembly on the base.

14. The apparatus of claim 10, further comprising an arm moveable over the label assembly, the aperture positioned within the arm.

* * * * *