

US006755273B2

(12) **United States Patent**
Breed

(10) **Patent No.:** **US 6,755,273 B2**
(45) **Date of Patent:** **Jun. 29, 2004**

(54) **COMBINED AIRBAG INFLATION AND OCCUPANT DISPLACEMENT ENABLING METHOD AND APPARATUS**

(75) Inventor: **David S. Breed**, Boonton Township, Morris County, NJ (US)

(73) Assignee: **Automotive Technologies International, Inc.**, Denville, NJ (US)

(*) Notice: Subject to any disclaimer, the term of this patent is extended or adjusted under 35 U.S.C. 154(b) by 110 days.

(21) Appl. No.: **10/097,082**

(22) Filed: **Mar. 13, 2002**

(65) **Prior Publication Data**

US 2002/0092693 A1 Jul. 18, 2002

Related U.S. Application Data

(63) Continuation-in-part of application No. 09/825,173, filed on Apr. 3, 2001, now Pat. No. 6,623,033, which is a continuation-in-part of application No. 09/024,085, filed on Feb. 17, 1998, now Pat. No. 6,209,909, which is a continuation-in-part of application No. 08/247,760, filed on May 23, 1994, now abandoned, and a continuation-in-part of application No. 09/307,883, filed on May 10, 1999, now Pat. No. 6,343,810.

(51) **Int. Cl.**⁷ **B60K 28/14**; B60R 21/22; B60R 22/20

(52) **U.S. Cl.** **180/274**; 180/282; 280/730.2; 280/735; 280/801.2

(58) **Field of Search** 180/268, 274, 180/282; 280/730.2, 734, 735, 801.1, 801.2, 805, 807; 296/65.01, 68.1, 65.06, 65.07, 65.11, 65.12, 65.13, 65.14, 65.15, 190.03; 297/216.1, 216.16, 216.18, 216.19, 216.2, 468, 470, 474, 475; 340/436; 342/70, 72; 701/45, 46, 47

(56) **References Cited**

U.S. PATENT DOCUMENTS

2,970,862 A * 2/1961 Racine 296/68.1
3,177,966 A * 4/1965 Schoeffler et al. 180/268

(List continued on next page.)

FOREIGN PATENT DOCUMENTS

DE 2922273 1/1981 280/735
DE 43 20 147 1/1994 280/735

(List continued on next page.)

OTHER PUBLICATIONS

Learned Classification of Sonar Targets Using a Massively Parallel Network, R. Paul Gorman and Terrance J. Seinowski, III Transactions on Acoustics, Speech & Signal Processing, vol. 36, No. 7, Jul. 1968, pp. 1135-1140.

(List continued on next page.)

Primary Examiner—Paul N. Dickson

Assistant Examiner—Laura B. Rosenly

(74) *Attorney, Agent, or Firm*—Brian Roffe

(57) **ABSTRACT**

Combined airbag inflation and occupant displacement enabling system including a seat movably attached to a floor pan of the vehicle for supporting an occupant, an airbag which is inflated to protect the occupant during a crash, a sensor which detects that a crash requiring deployment of the airbag is required and an inflator which inflates the airbag. The inflator is coupled to the sensor and is triggered to inflate the airbag in response to the detection by the sensor of a crash requiring deployment of the airbag. The seat is arranged to move upon inflation of the airbag whereby movement of the seat causes displacement of the occupant. If an anticipatory sensor is provided, the seat can be designed to move at any time after a determination is made that a crash will occur.

47 Claims, 29 Drawing Sheets

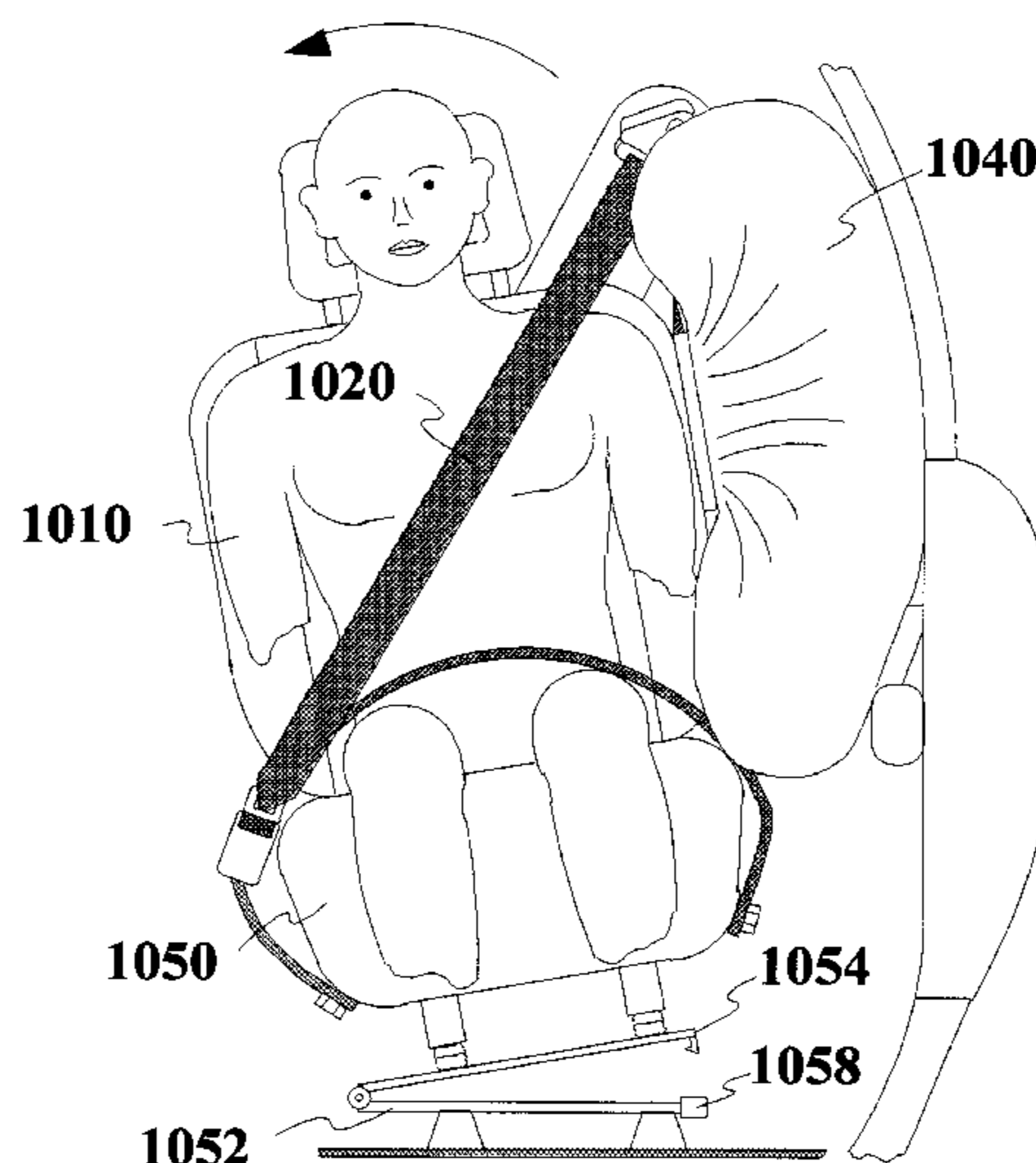

U.S. PATENT DOCUMENTS

3,322,458	A	*	5/1967	Bachmann	196/65.07
3,725,398	A		4/1973	Ross	280/735
3,741,584	A		6/1973	Arai	280/735
3,822,076	A		7/1974	Mercier et al.	293/107
3,861,710	A		1/1975	Okubo	280/735
3,874,695	A		4/1975	Abe et al.	280/735
3,900,210	A		8/1975	Lohr et al.	280/729
3,922,030	A	*	11/1975	Stedman	296/68.1
3,951,430	A	*	4/1976	Schwanz et al.	297/480
3,981,518	A	*	9/1976	Pulling	280/730.1
4,243,248	A		1/1981	Scholz et al.	280/735
4,257,705	A		3/1981	Hosoe et al.	356/1
4,381,829	A	*	5/1983	Montaron	180/274
4,396,220	A	*	8/1983	Dieckmann et al.	296/68.1
4,625,329	A		11/1986	Ishikawa et al.	180/271
4,792,188	A	*	12/1988	Kawashima	397/344.26
4,924,774	A	*	5/1990	Lenzen	102/202.7
4,966,388	A		10/1990	Warner et al.	280/730 A
4,984,651	A	*	1/1991	Grosch et al.	180/268
5,008,946	A		4/1991	Ando	180/271
5,022,707	A	*	6/1991	Beauvais et al.	297/216.2
5,112,079	A		5/1992	Haland et al.	280/730.2
5,149,165	A		9/1992	Woolley	296/68.1
5,167,421	A	*	12/1992	Yunzhao	297/216.18
5,231,253	A		7/1993	Breed et al.	200/61.45 R
5,249,157	A		9/1993	Taylor	340/903
5,251,931	A	*	10/1993	Semchena et al.	280/730.1
5,282,134	A		1/1994	Gioutsos et al.	364/424.05
5,285,188	A		2/1994	Yoshida	280/735
5,307,136	A		4/1994	Saneyoshi	180/167
5,328,234	A	*	7/1994	Daniel et al.	297/216.16
5,330,226	A		7/1994	Gentry et al.	280/739
5,344,204	A	*	9/1994	Liu, Yunzhao	296/68.1
5,377,108	A		12/1994	Nishio	364/424.05
5,394,326	A		2/1995	Liu	364/424.05
5,567,006	A	*	10/1996	McCarthy	297/216.15

5,583,771	A		12/1996	Lynch et al.	364/424.05
5,667,246	A		9/1997	Miller, III	280/806
5,785,347	A		7/1998	Adolph et al.	280/735
5,810,427	A		9/1998	Hartmann et al.	296/189
5,951,073	A		9/1999	Hall	293/119
5,967,573	A		10/1999	Wang	293/119
6,056,336	A		5/2000	Balgobin	293/107
6,059,330	A		5/2000	Moffett et al.	293/118
6,106,038	A		8/2000	Dreher	293/118
6,174,008	B1		1/2001	Kramer et al.	293/118
6,209,909	B1		4/2001	Breed	280/735
6,224,120	B1		5/2001	Eipper et al.	293/118
6,343,810	B1		2/2002	Breed	280/730.2

FOREIGN PATENT DOCUMENTS

EP	0210079		1/1987	280/735
EP	0568017		11/1993		
GB	1333269		10/1973		
GB	2289786		11/1995		
JP	4293641		10/1992	180/274
JP	5143897		6/1993	340/903
JP	06055985	A	*	3/1994 B60R/21/16
WO	8605149		9/1986	180/274

OTHER PUBLICATIONS

Analysis of Hidden Units in a Layered Network Trained to Classify Sonar Targets, Neural networks, R. Paul Gorman and Terrence J. Sejnowski, vol. 1, 1988, pp. 75-89.
Trends in Sensing Side Impacts, V. Castelli and D. Breed, SAE Paper No. 890603, Feb. 27-Mar. 3, 1989.
Sensing Side IMpacts, D. Breed, W.T. Sanders, V. Castelli, SAE Paper No. 940561, Feb. 28-Mar. 3, 1994.
Side Impact Airbag System Technology, D. Breed, International Body Engineering Conference '94, Sep.26-29, 1994.

* cited by examiner

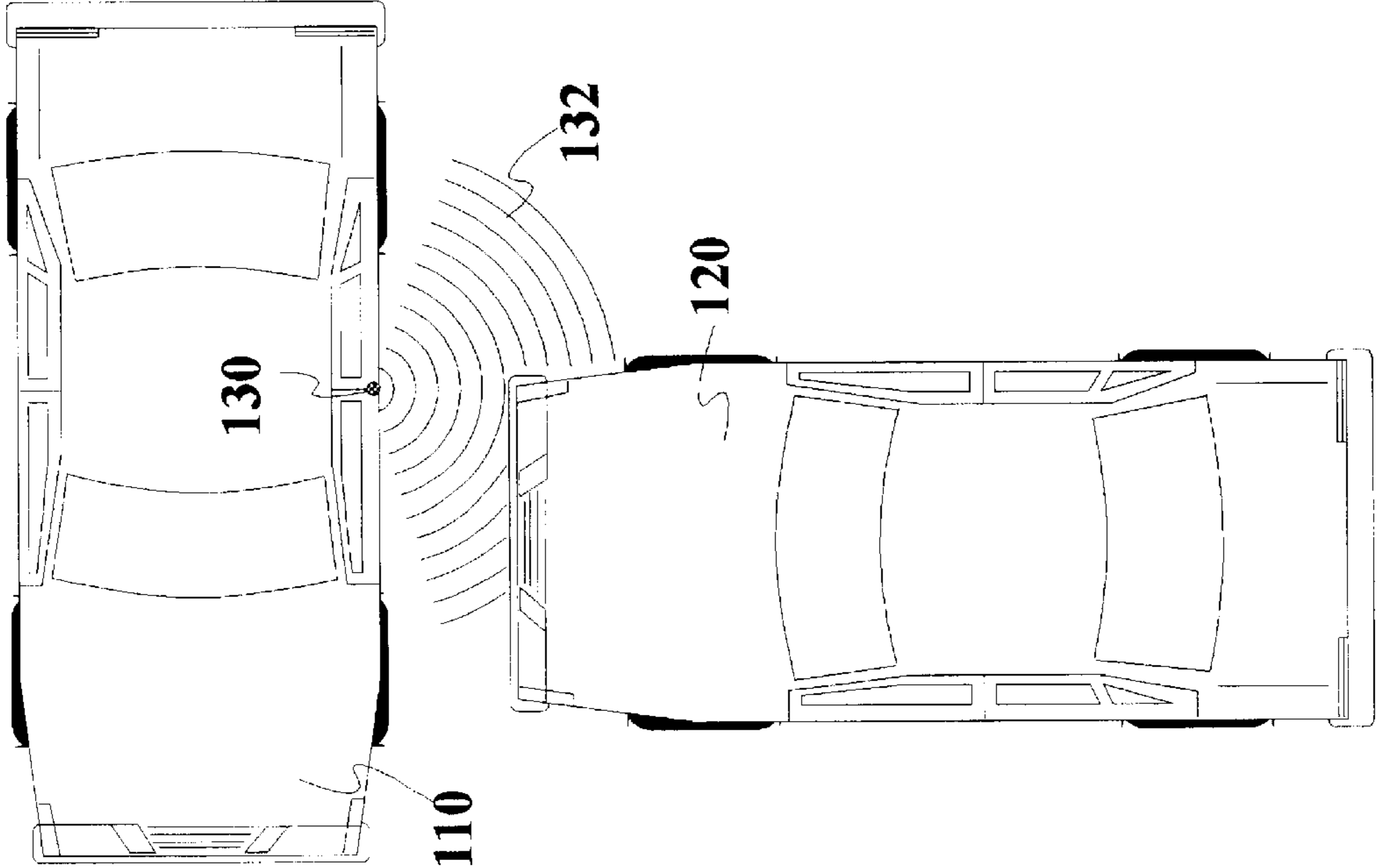

FIG. 1

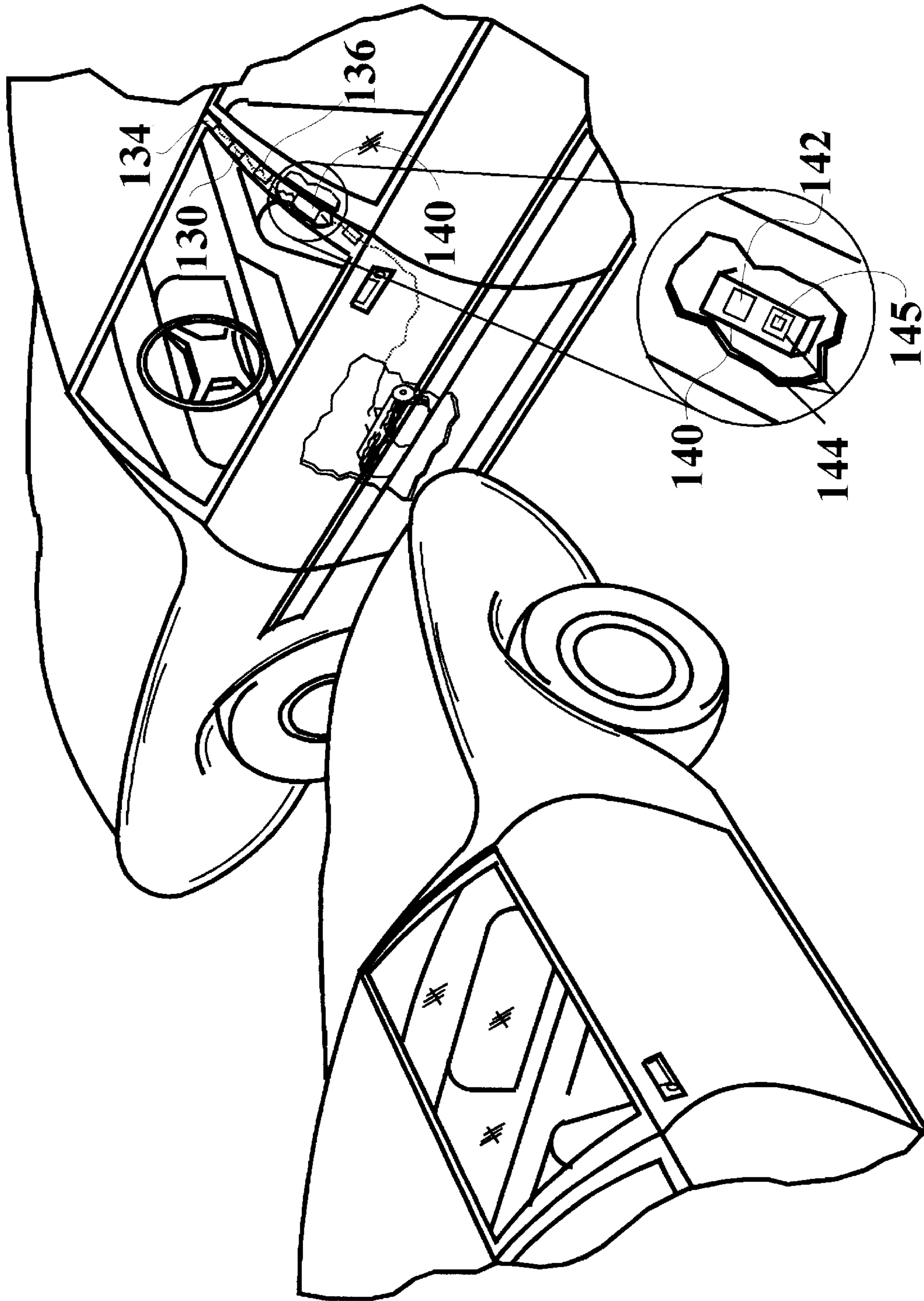

FIG. 1A

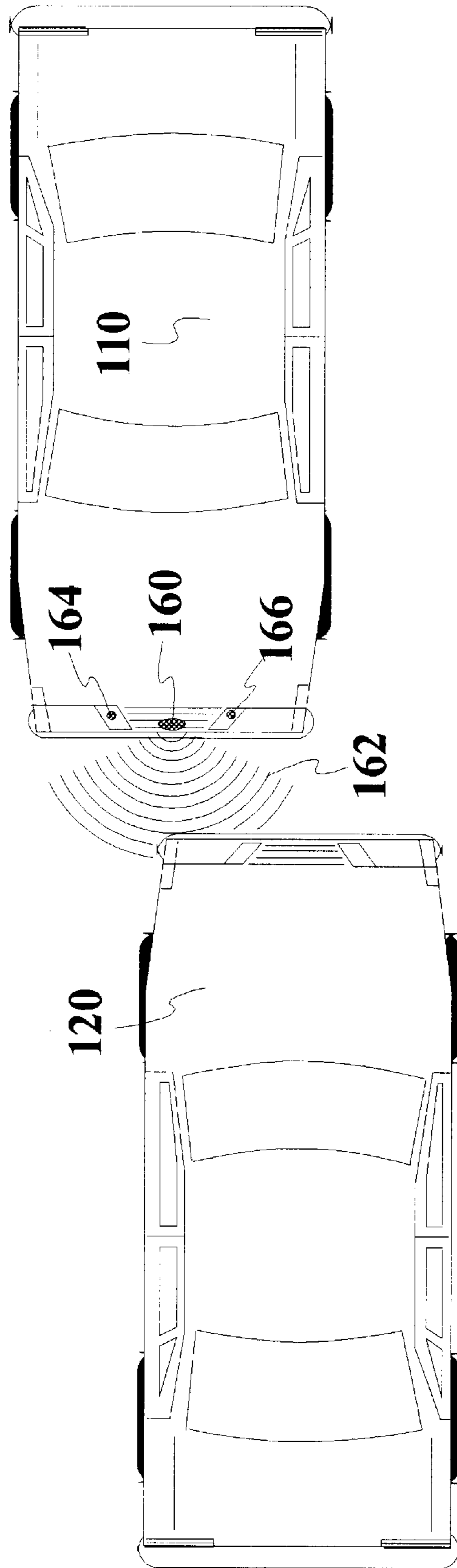

FIG. 2

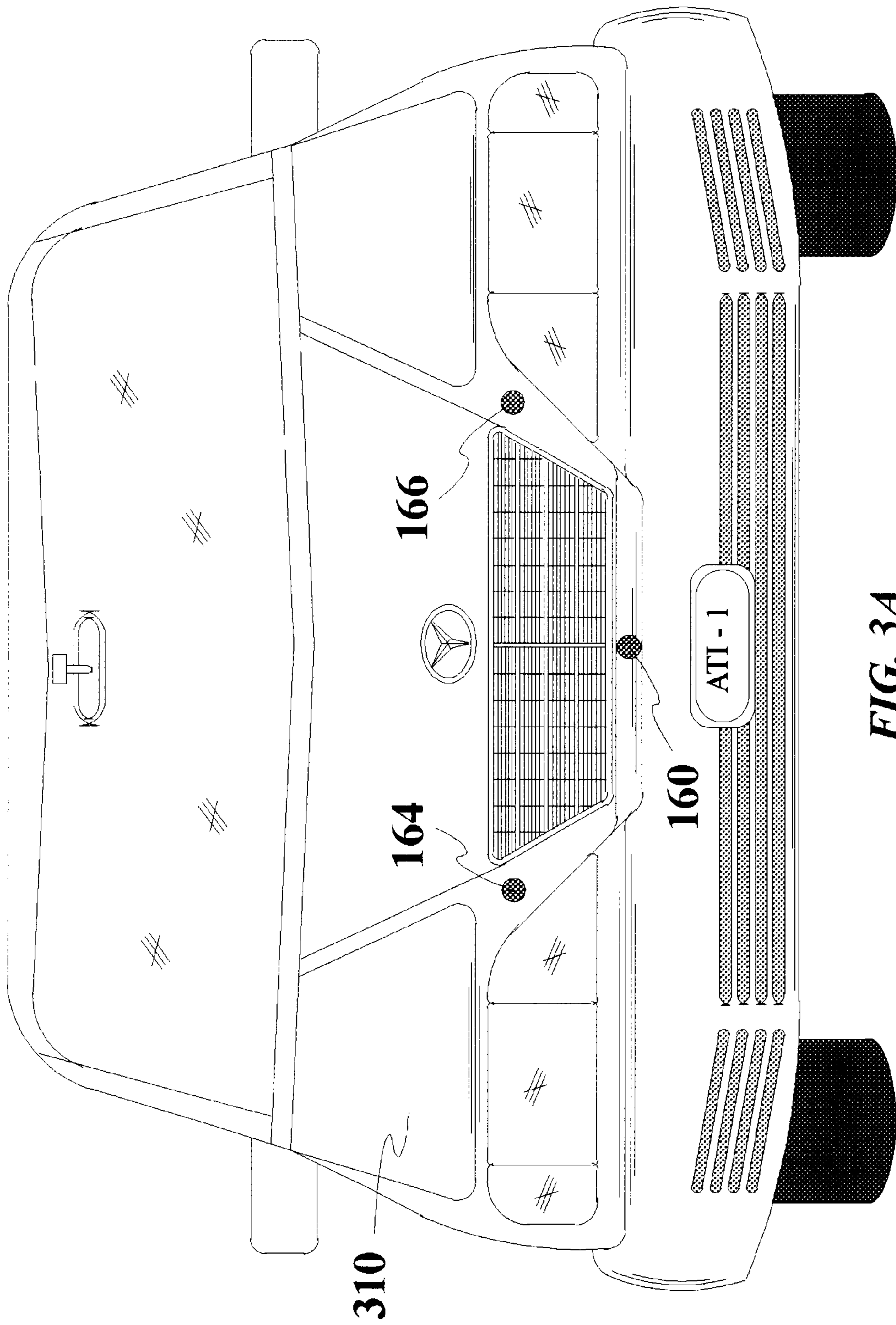

FIG. 3A

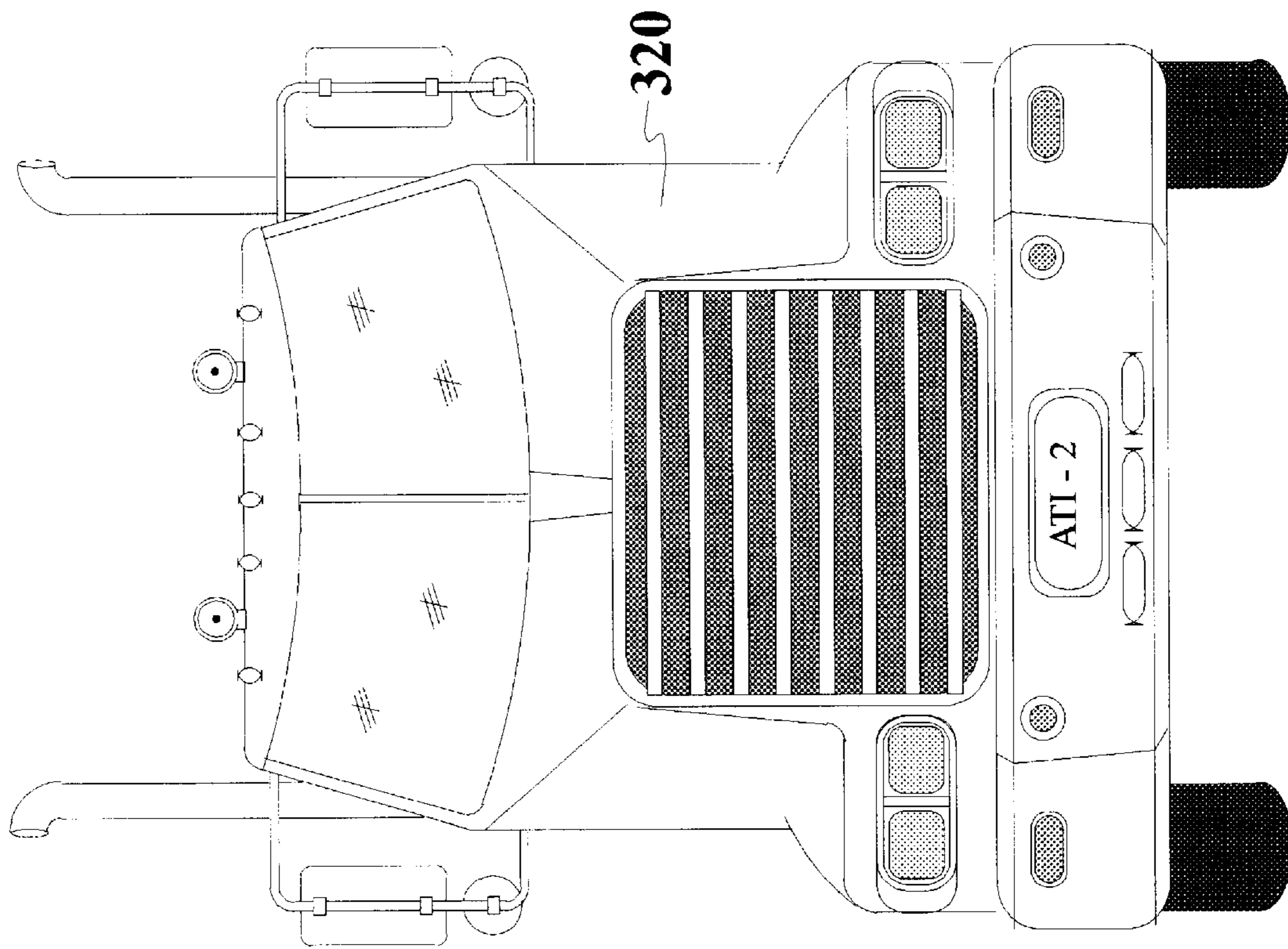

FIG. 3B

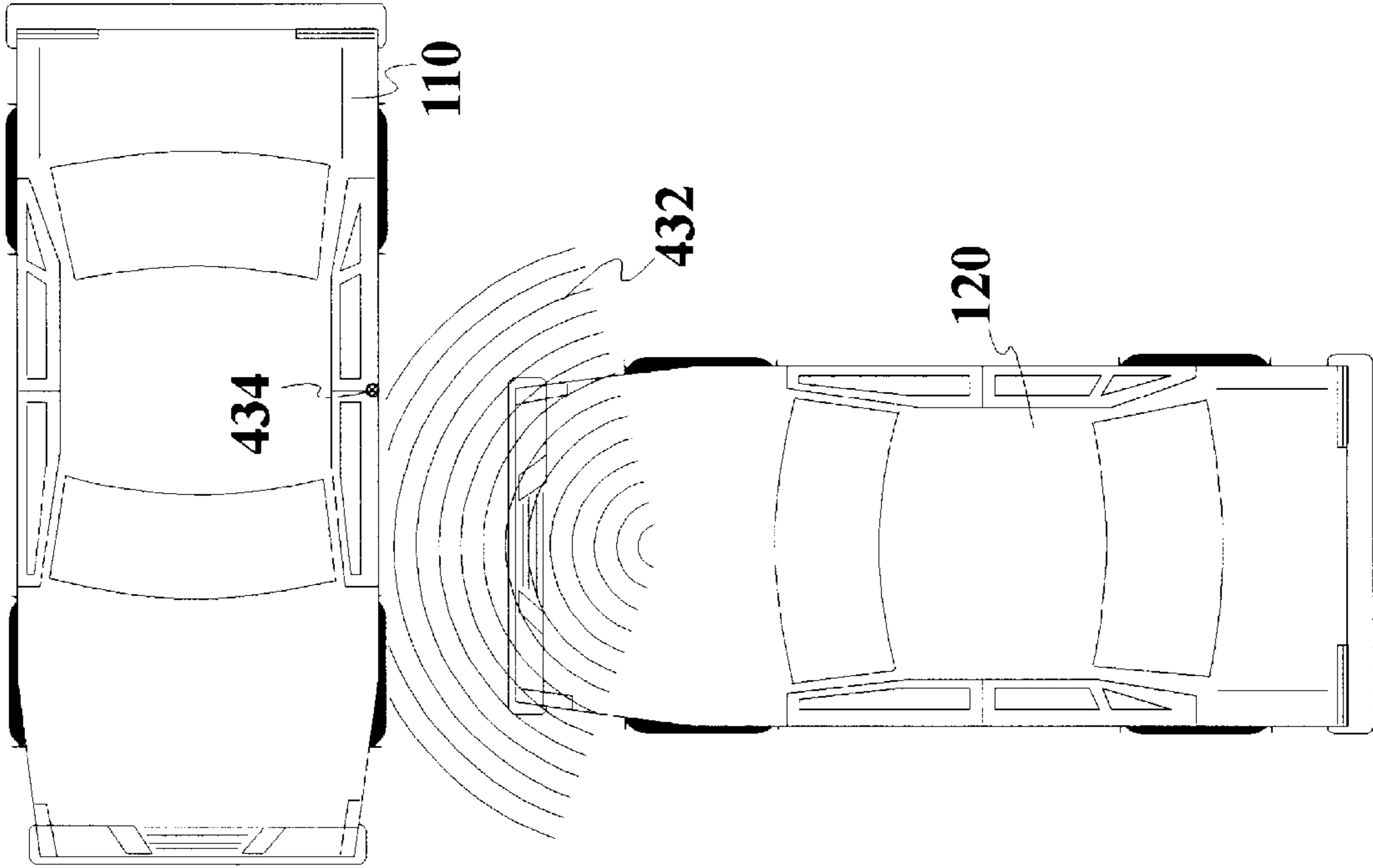

FIG. 4

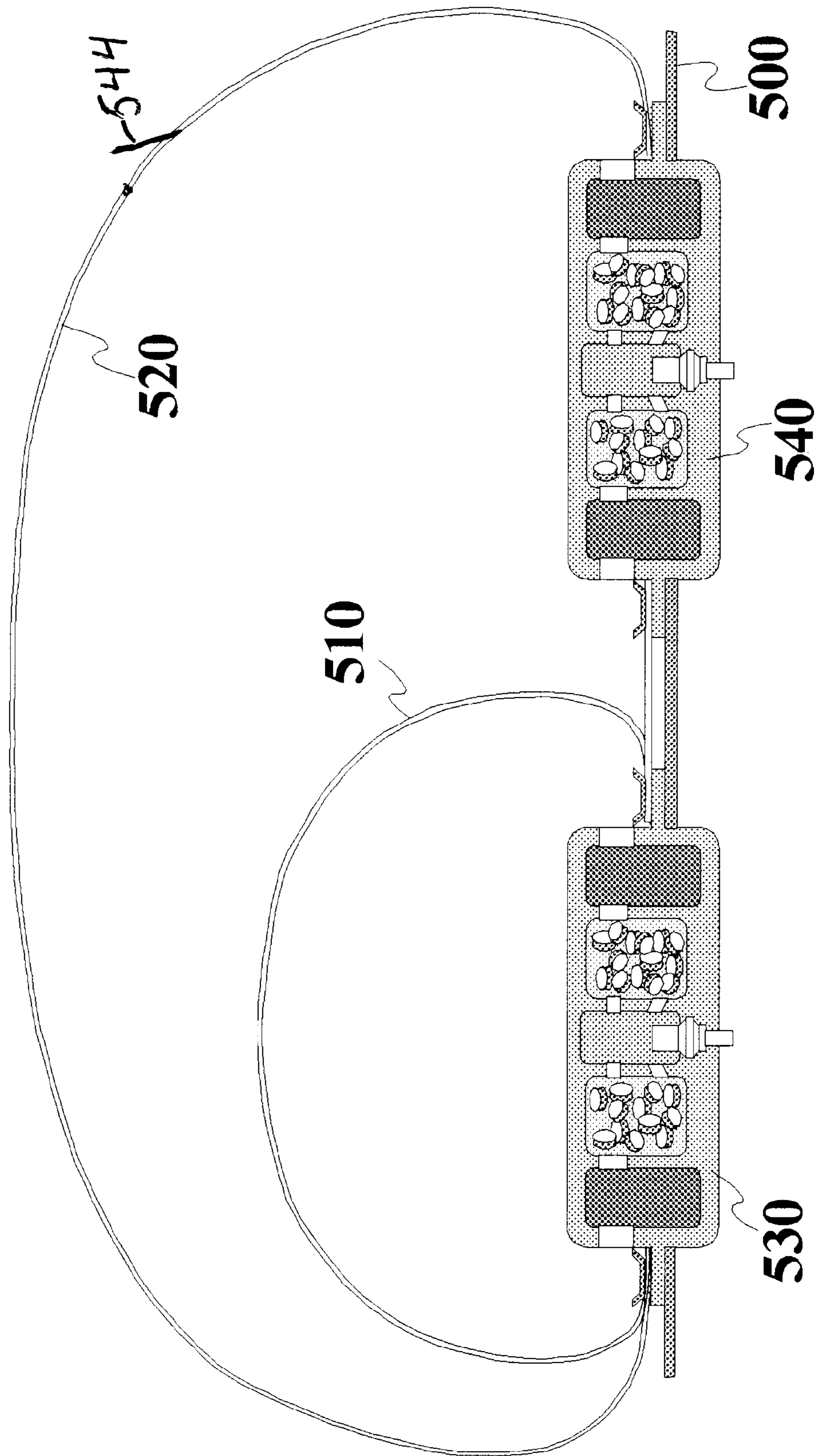
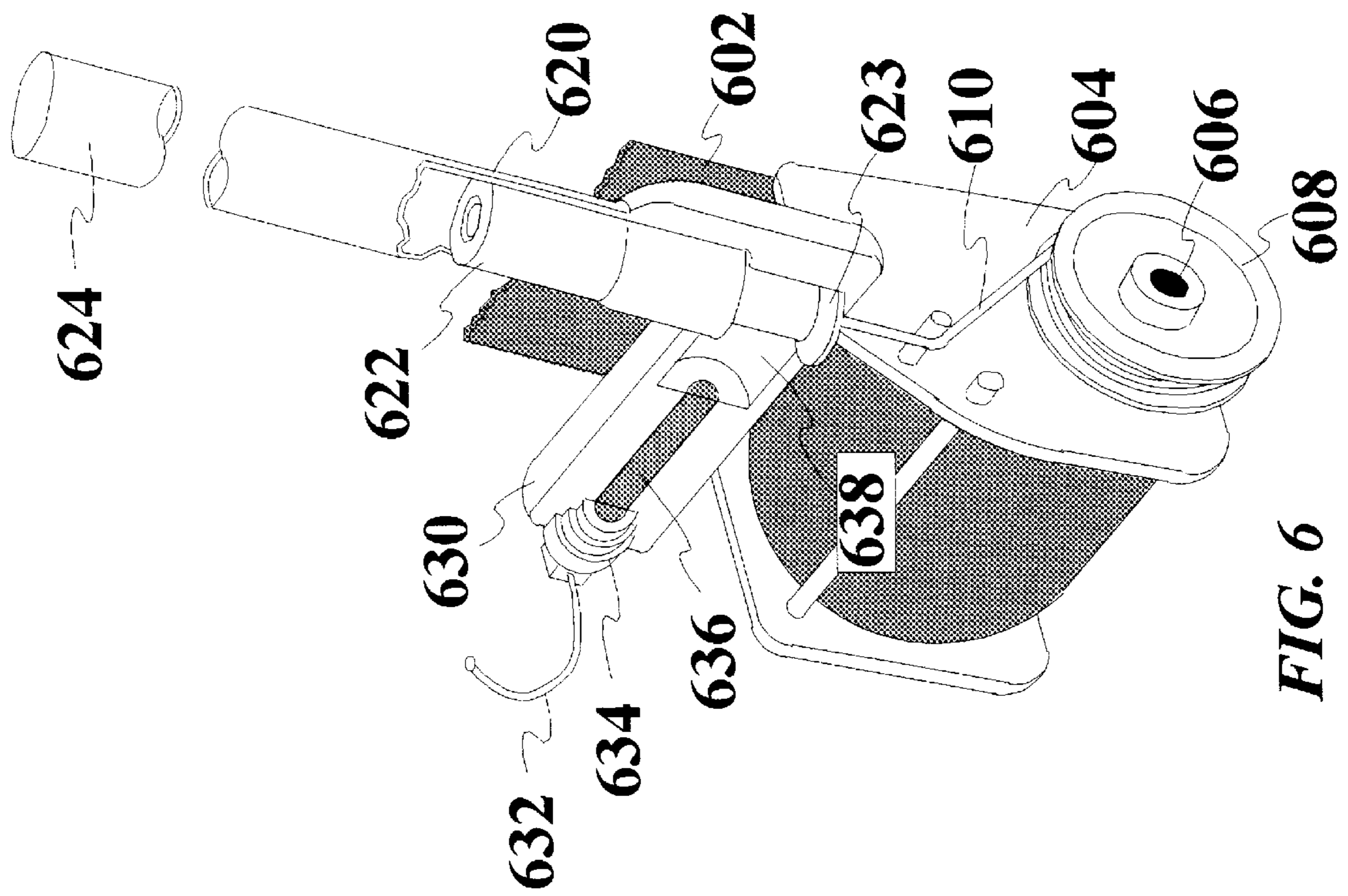

FIG. 5



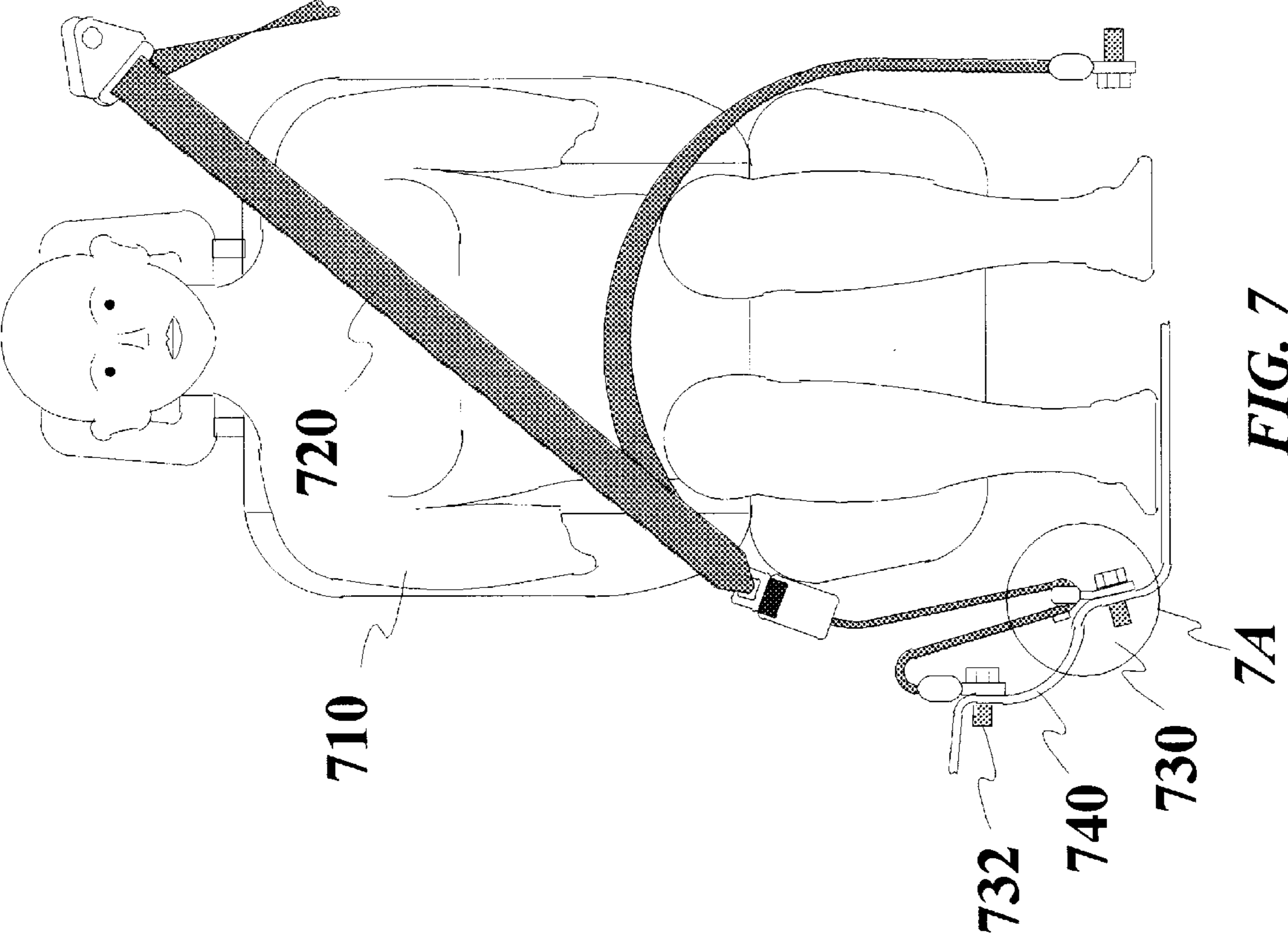
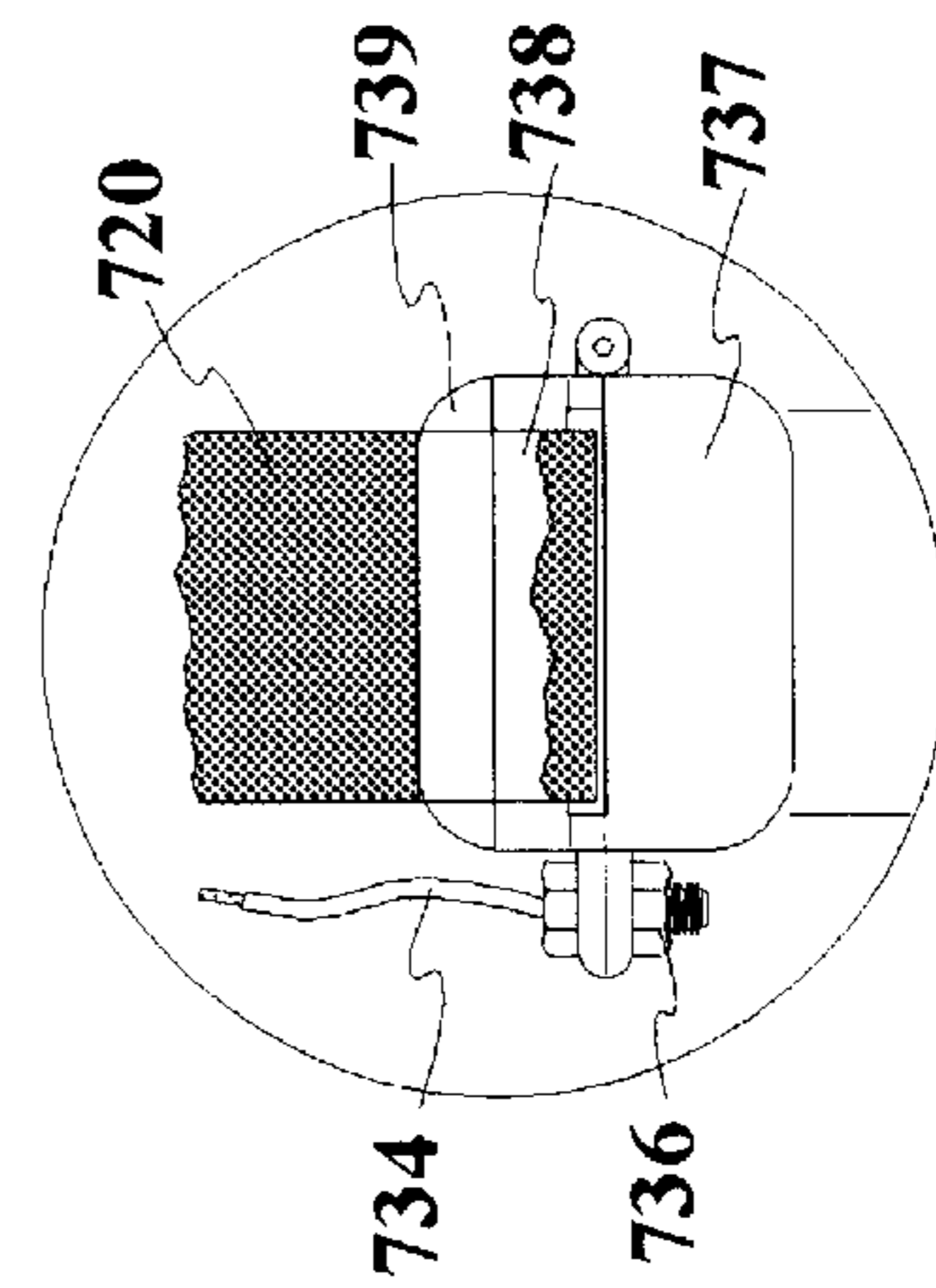
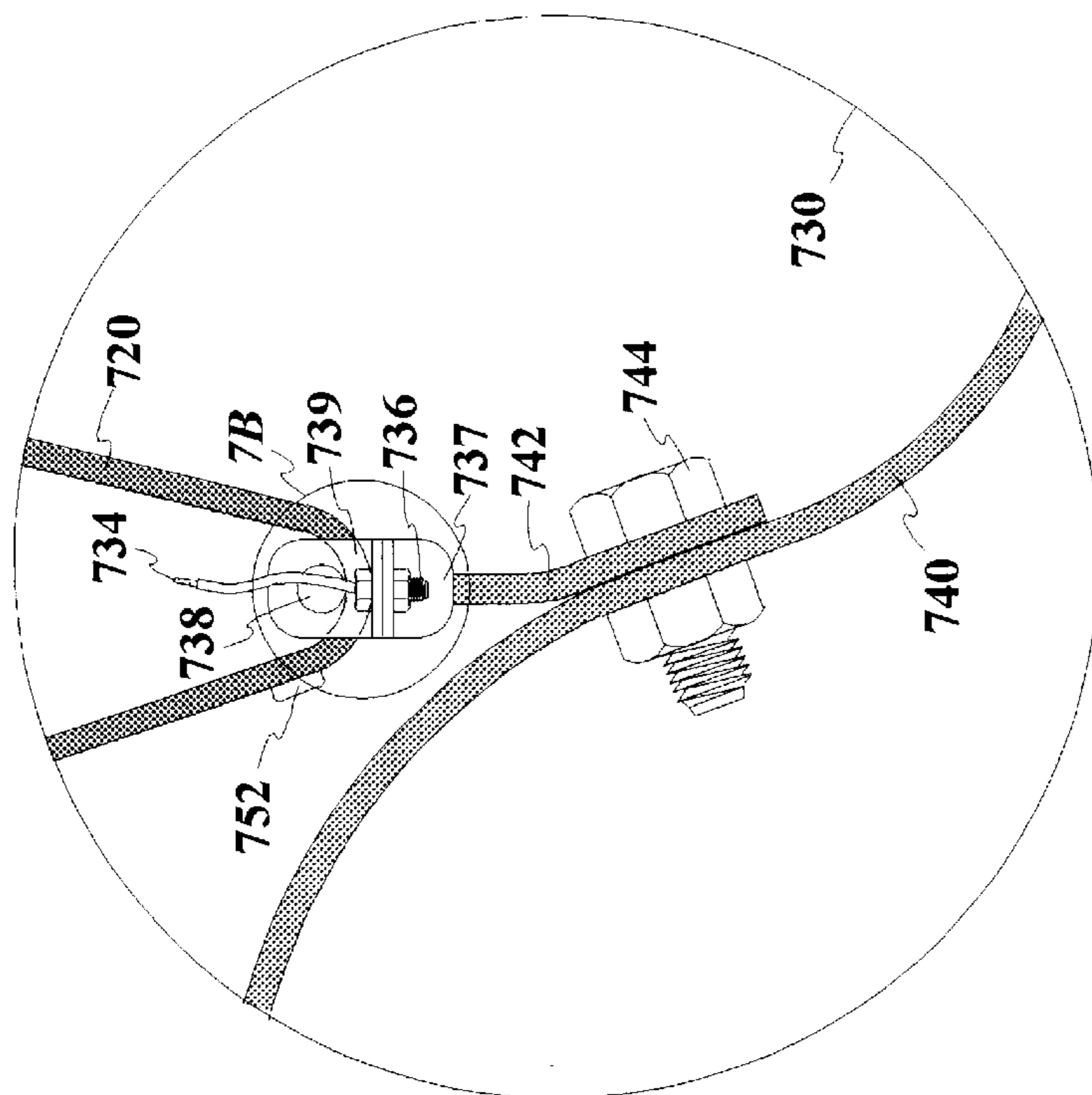

FIG. 7



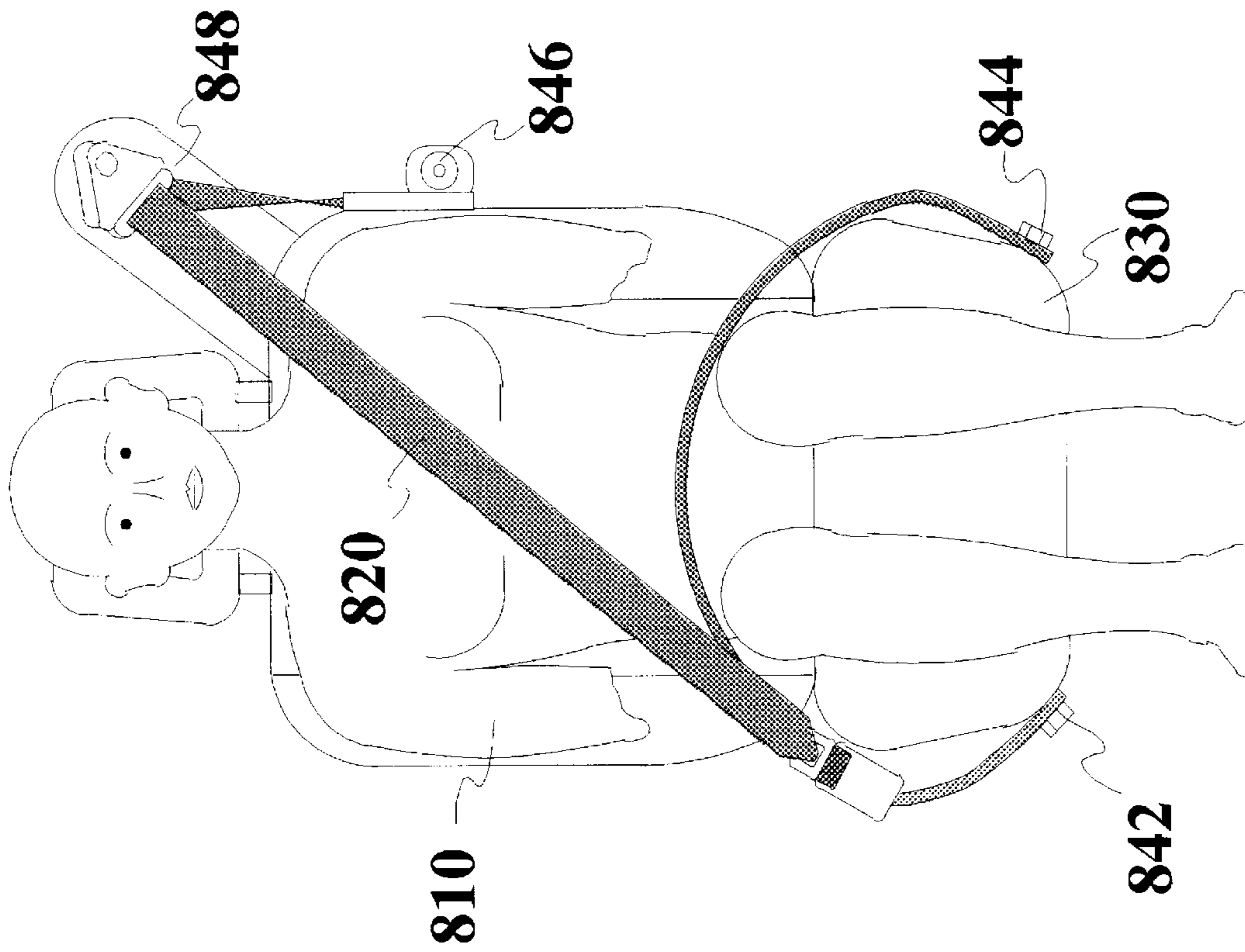

FIG. 8

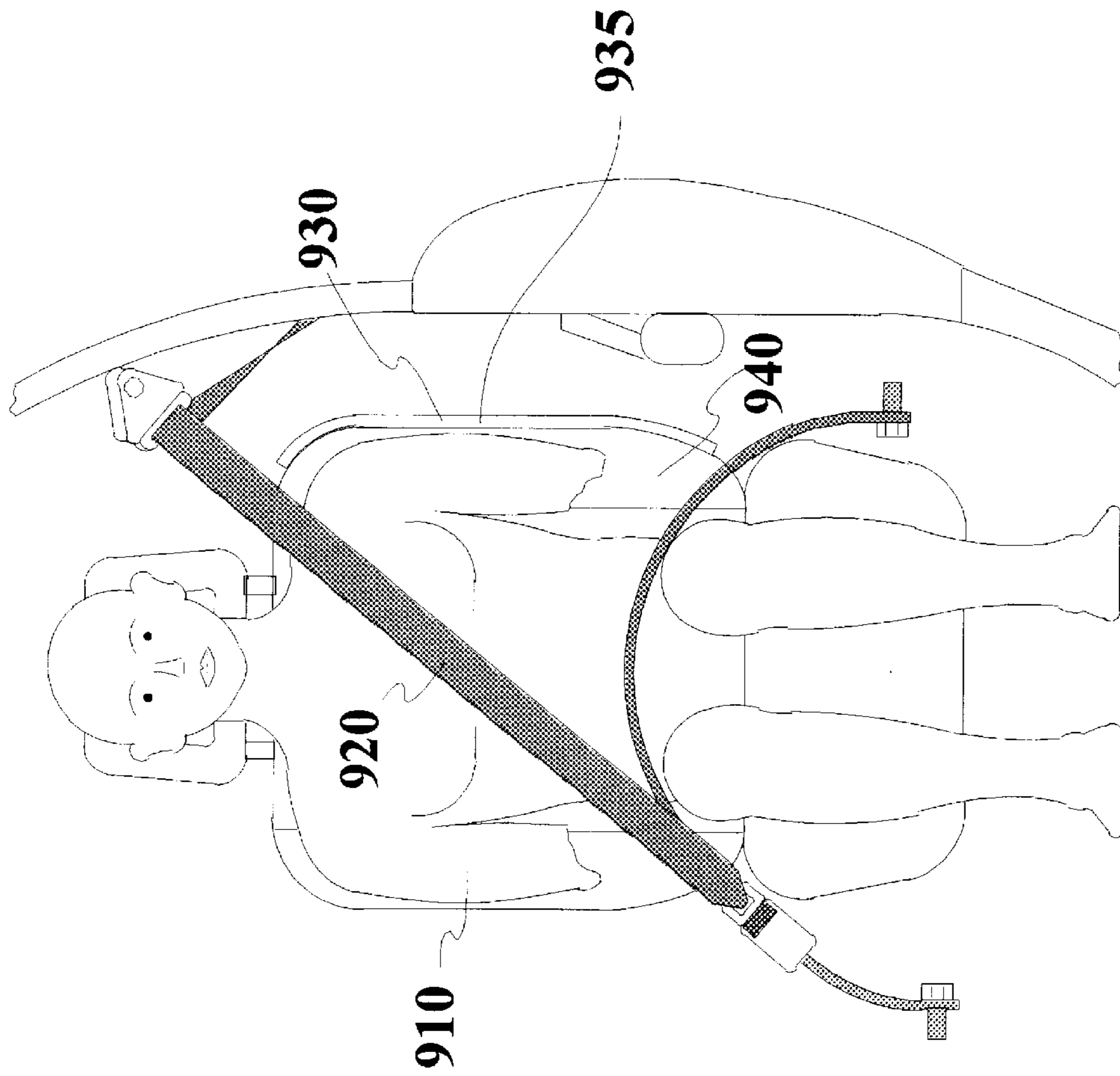

FIG. 9A

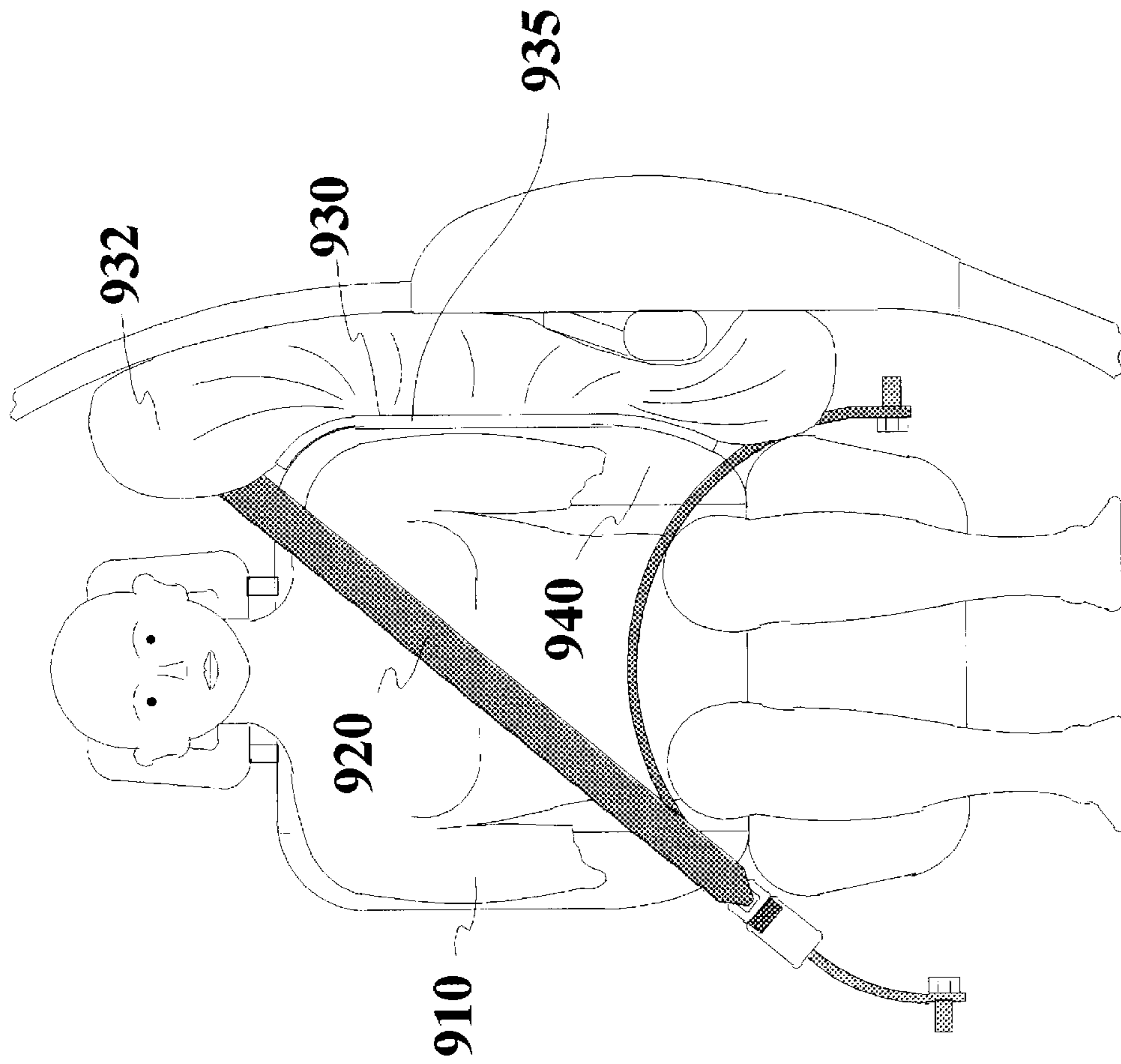

FIG. 9B

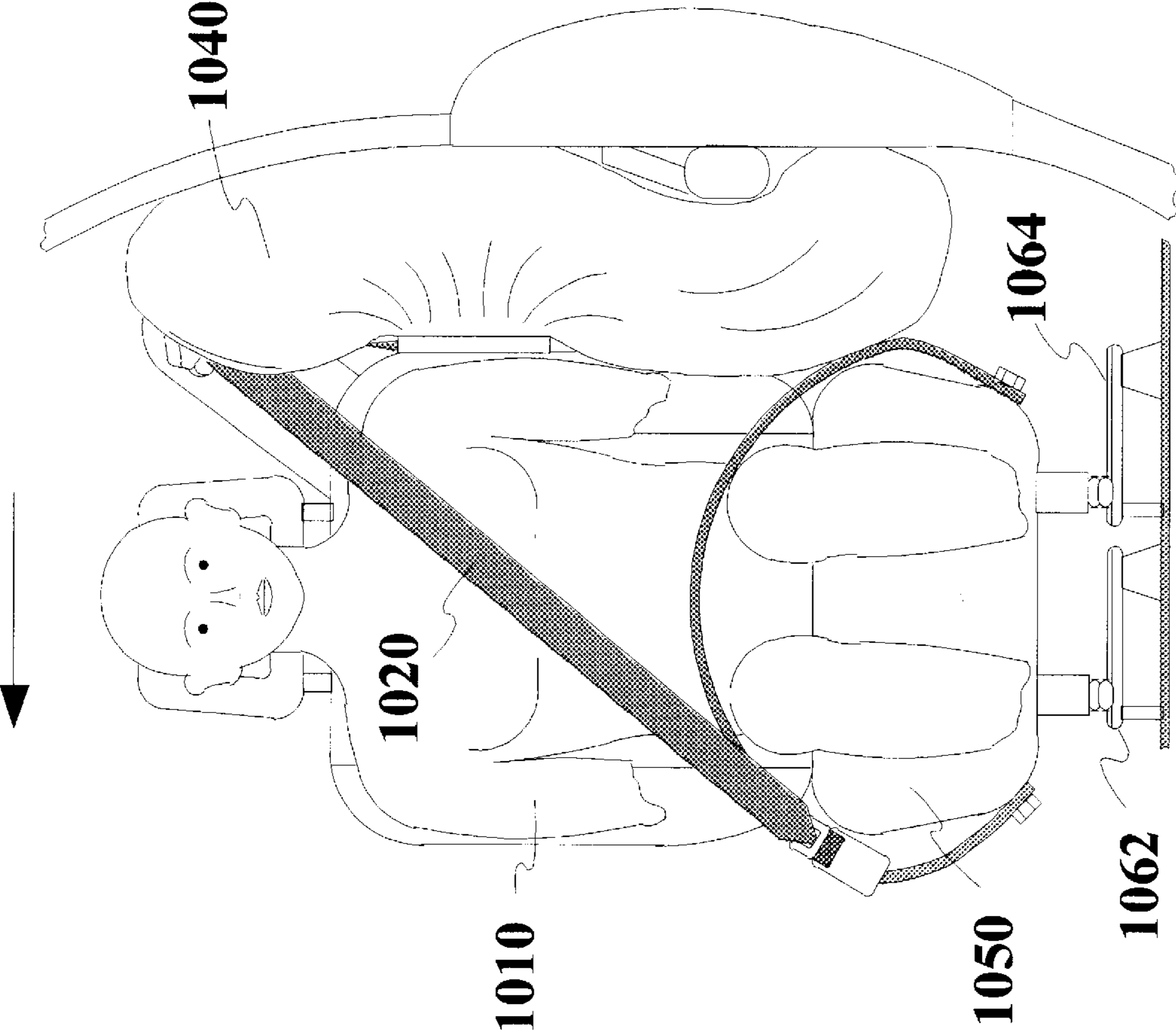

FIG. 10A

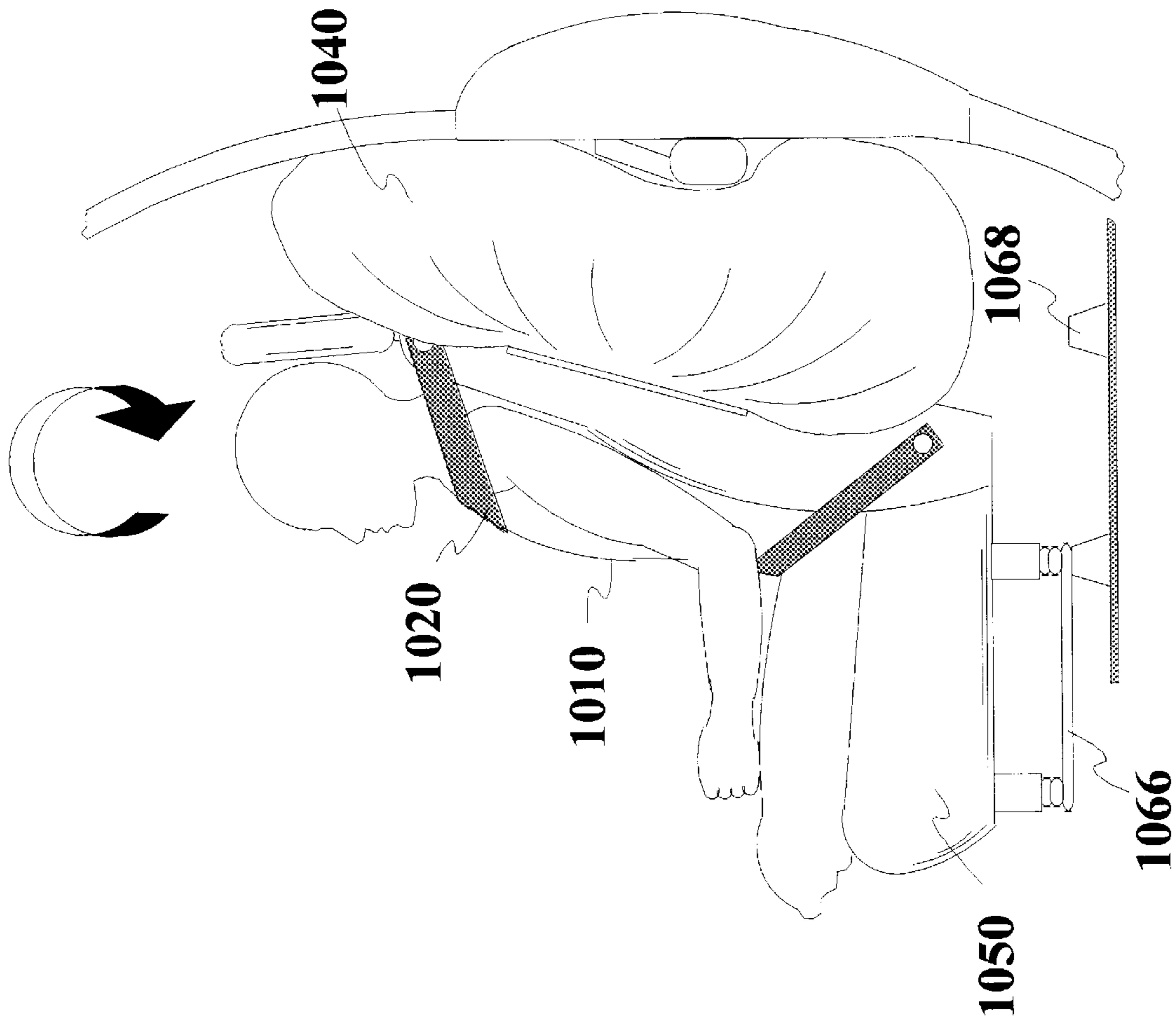

FIG. 10B

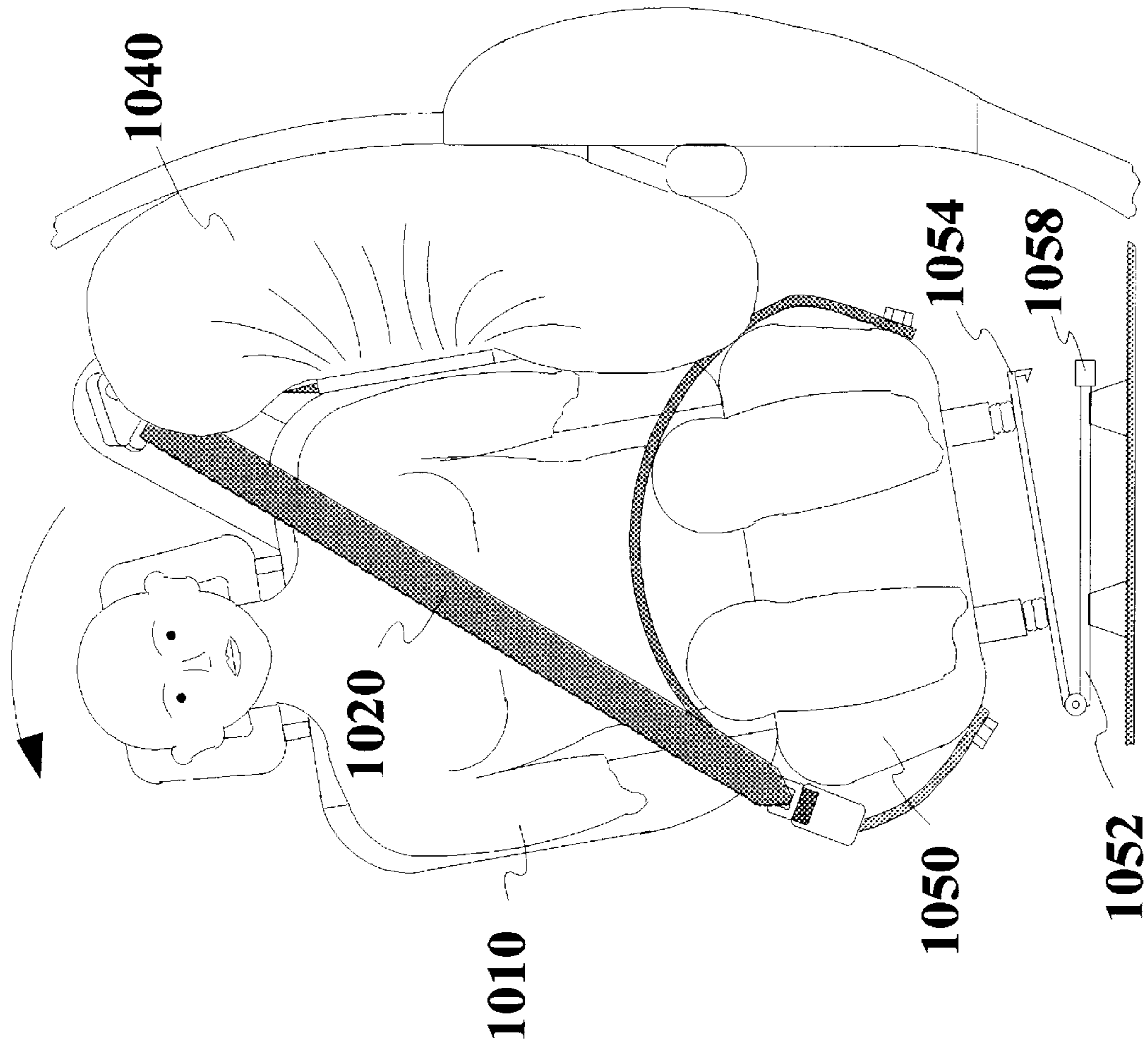

FIG. 10C

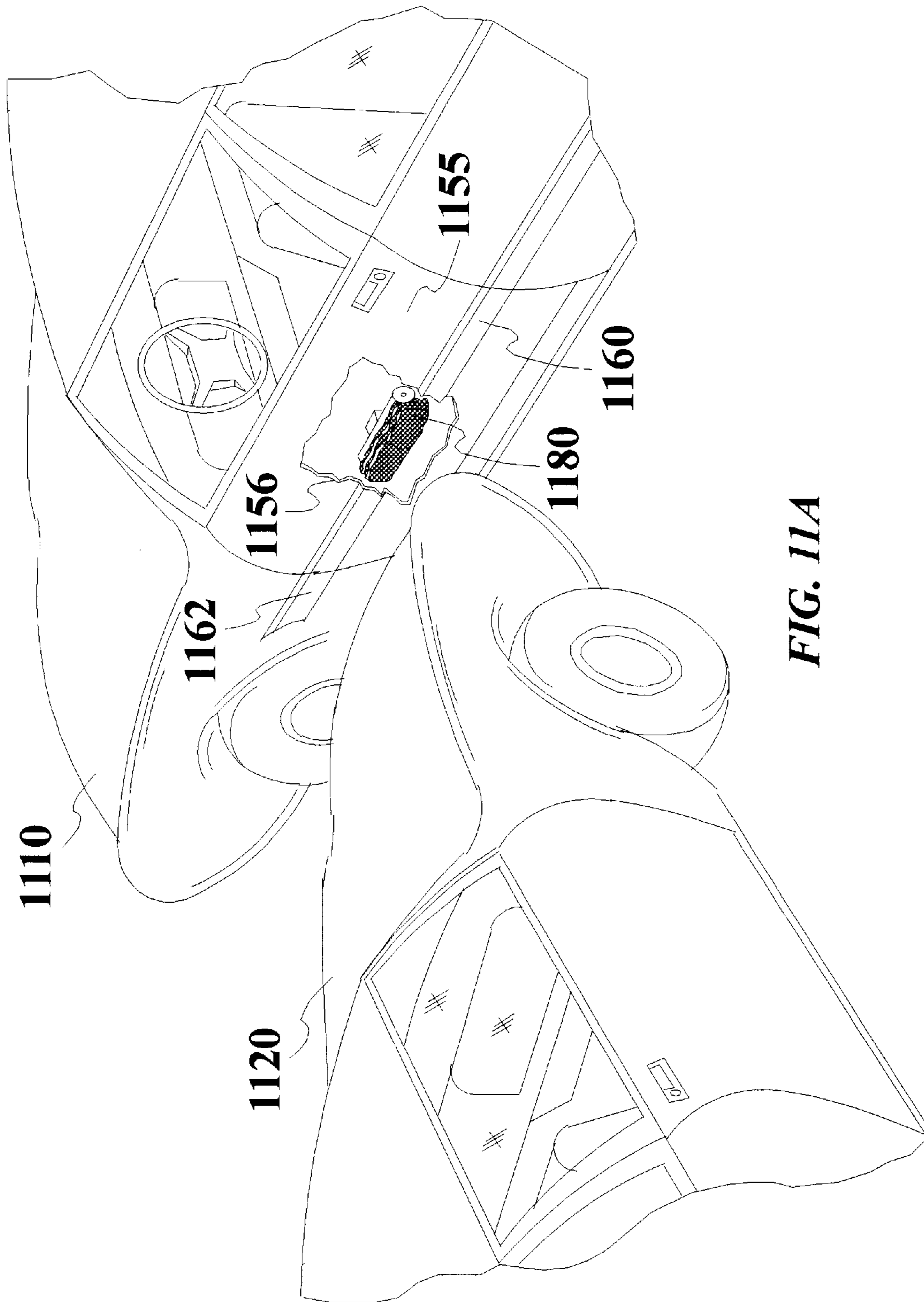

FIG. 11A

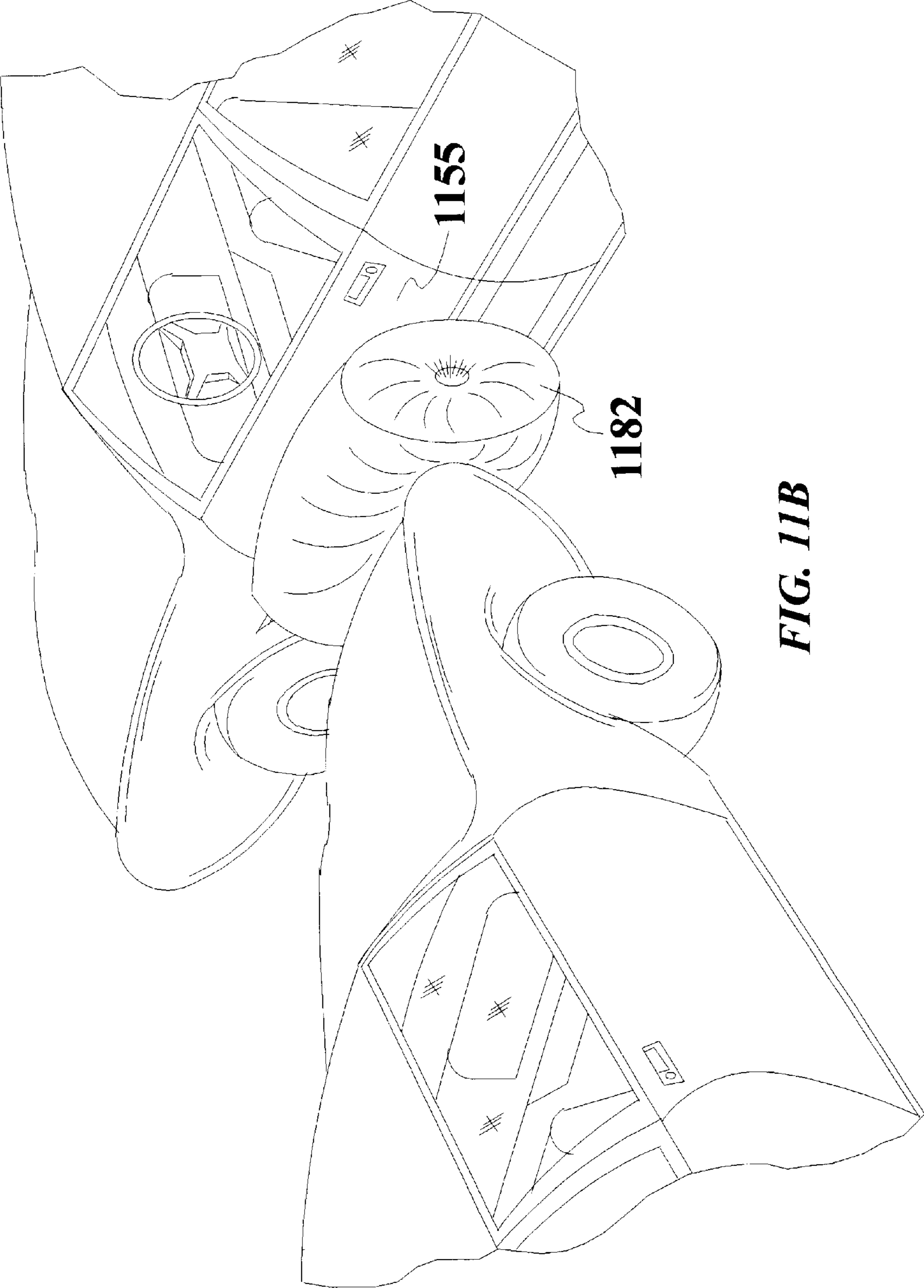

FIG. 11B

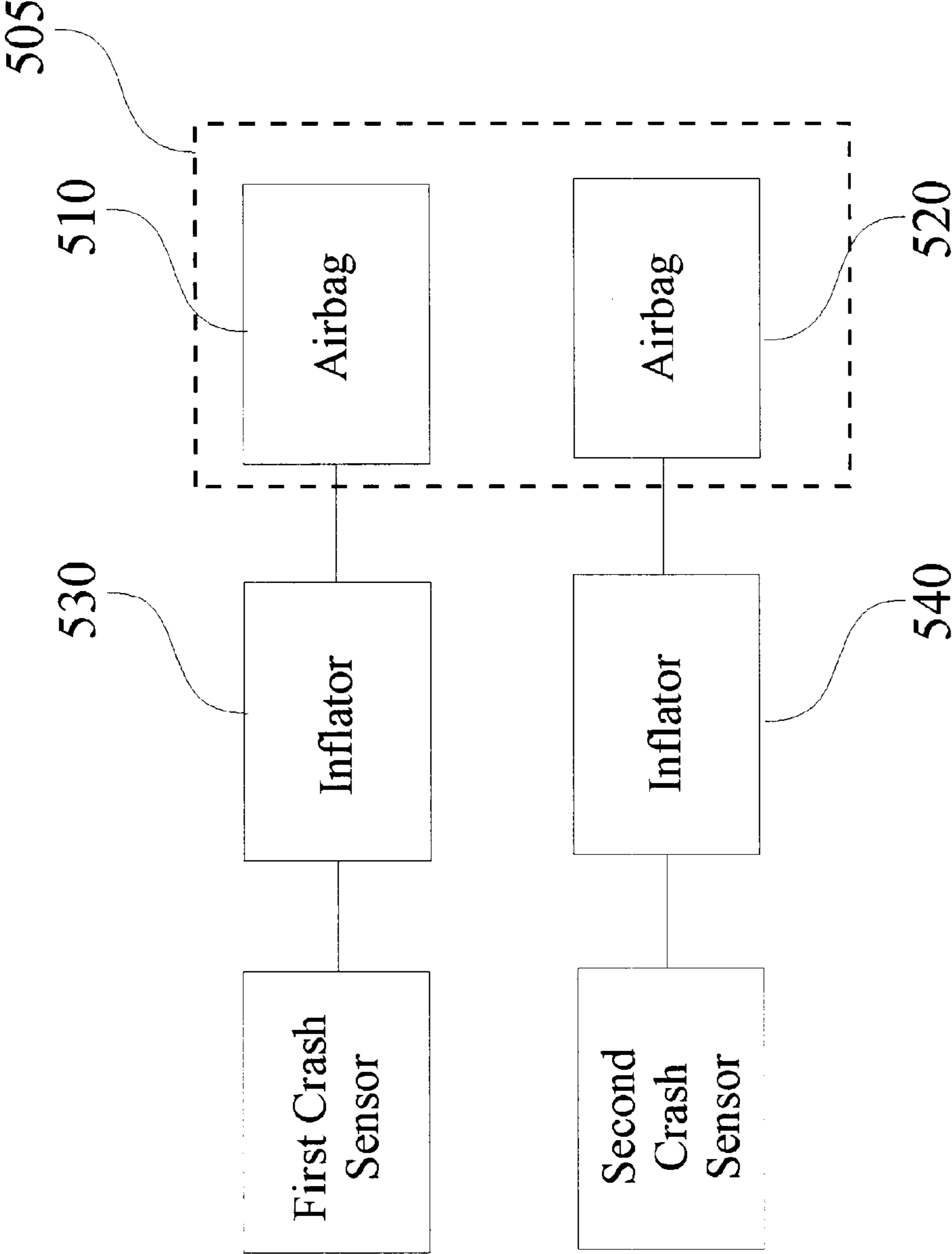

FIG. 12

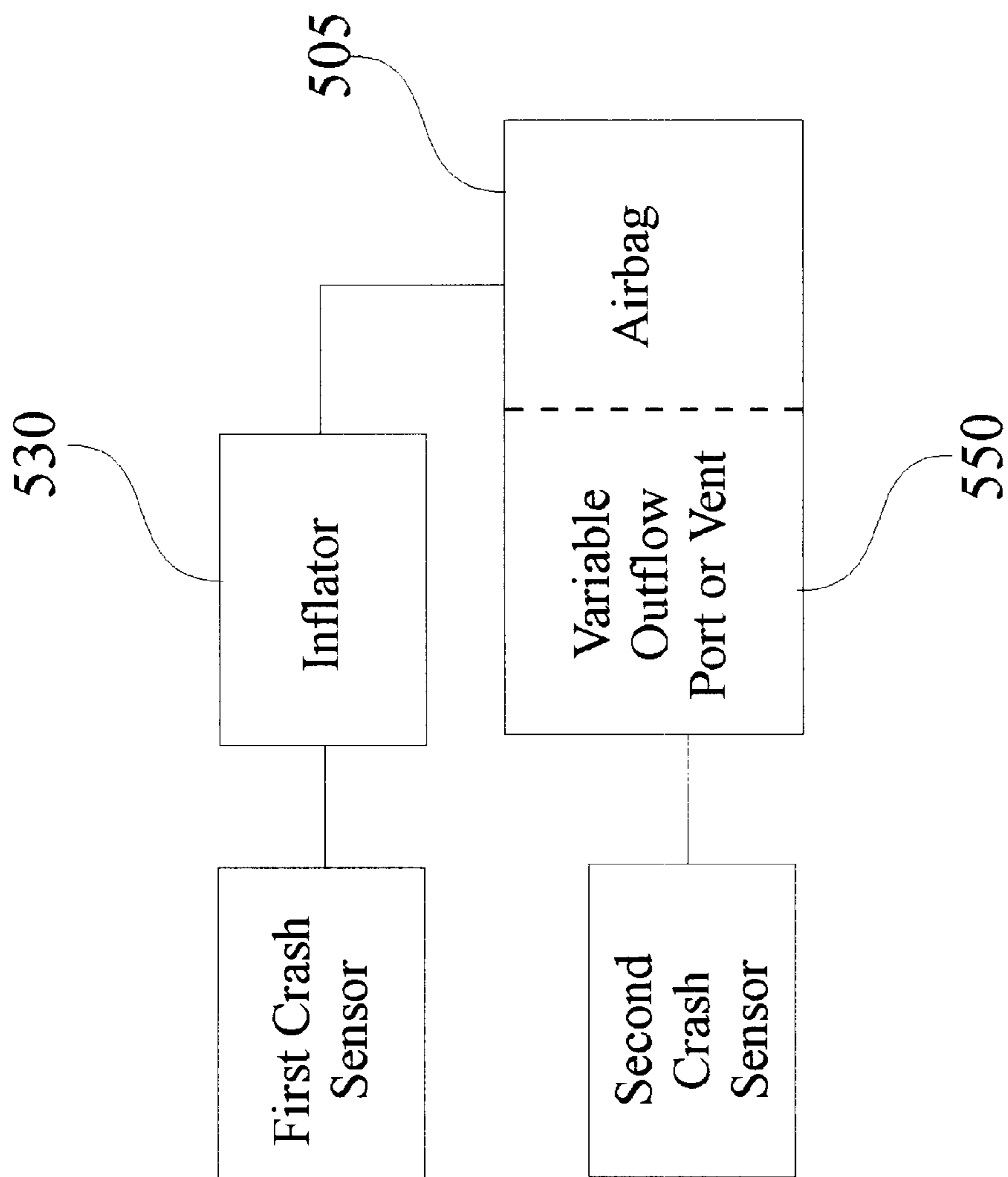

FIG. 13

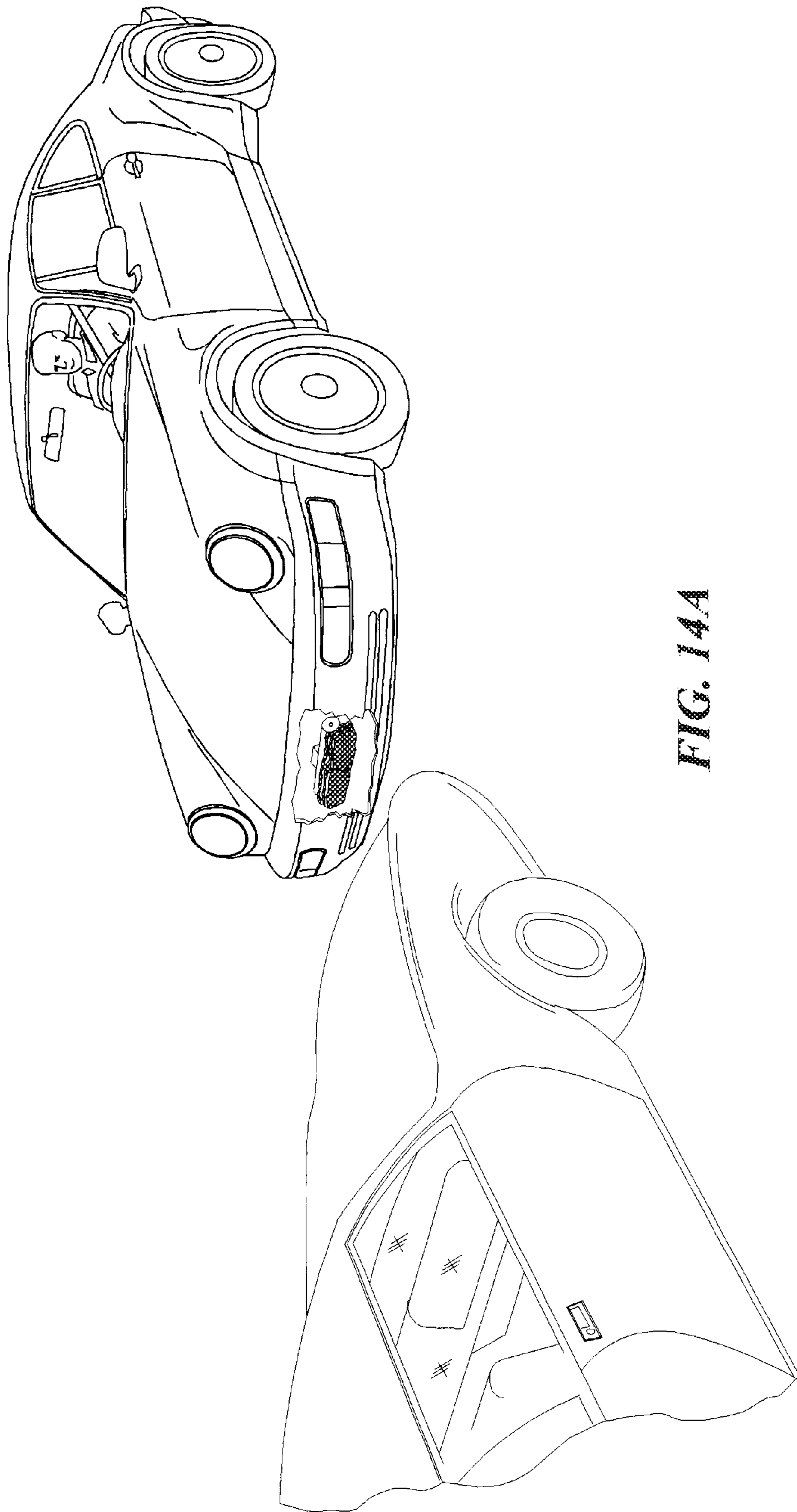

FIG. 14A

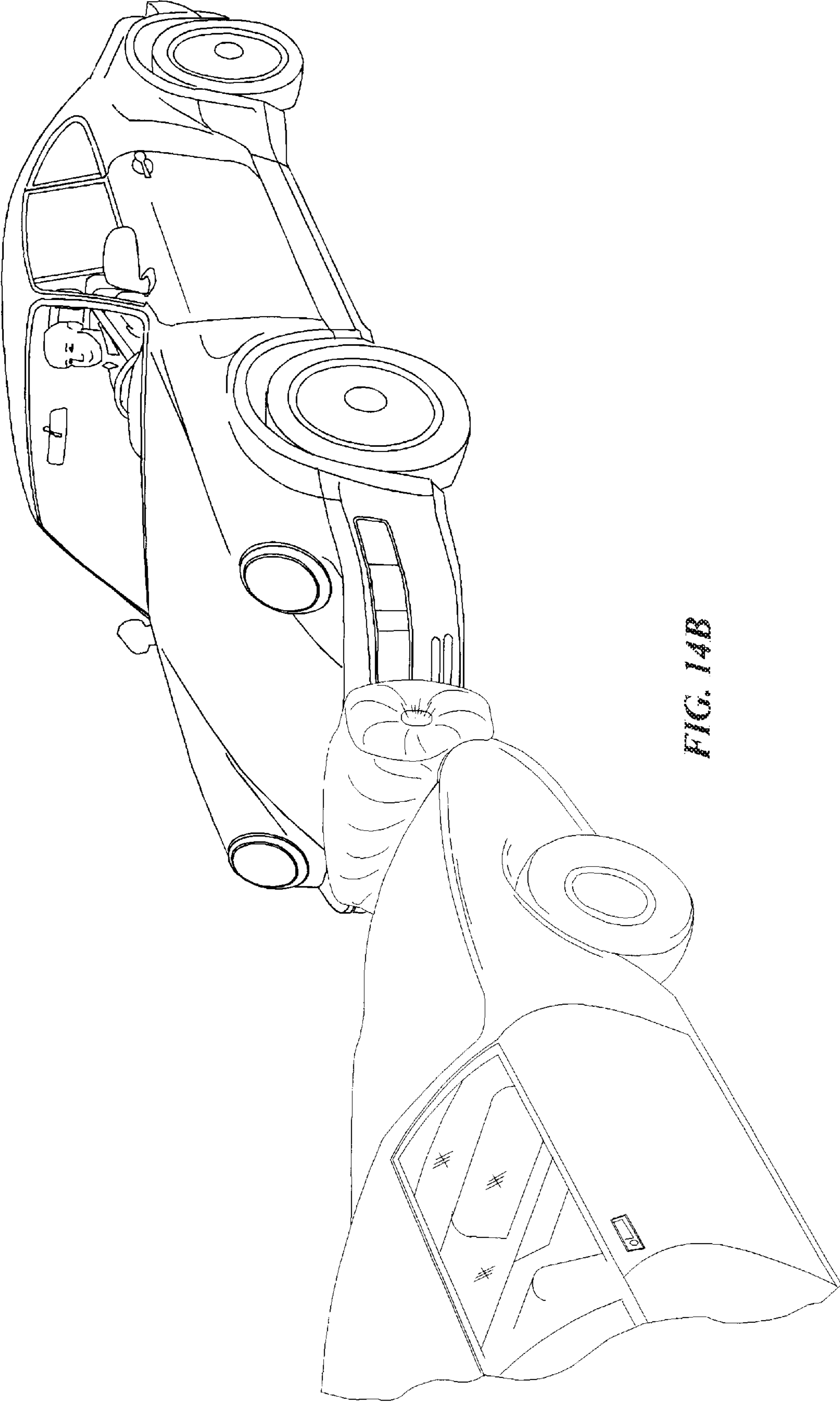

FIG. 14B

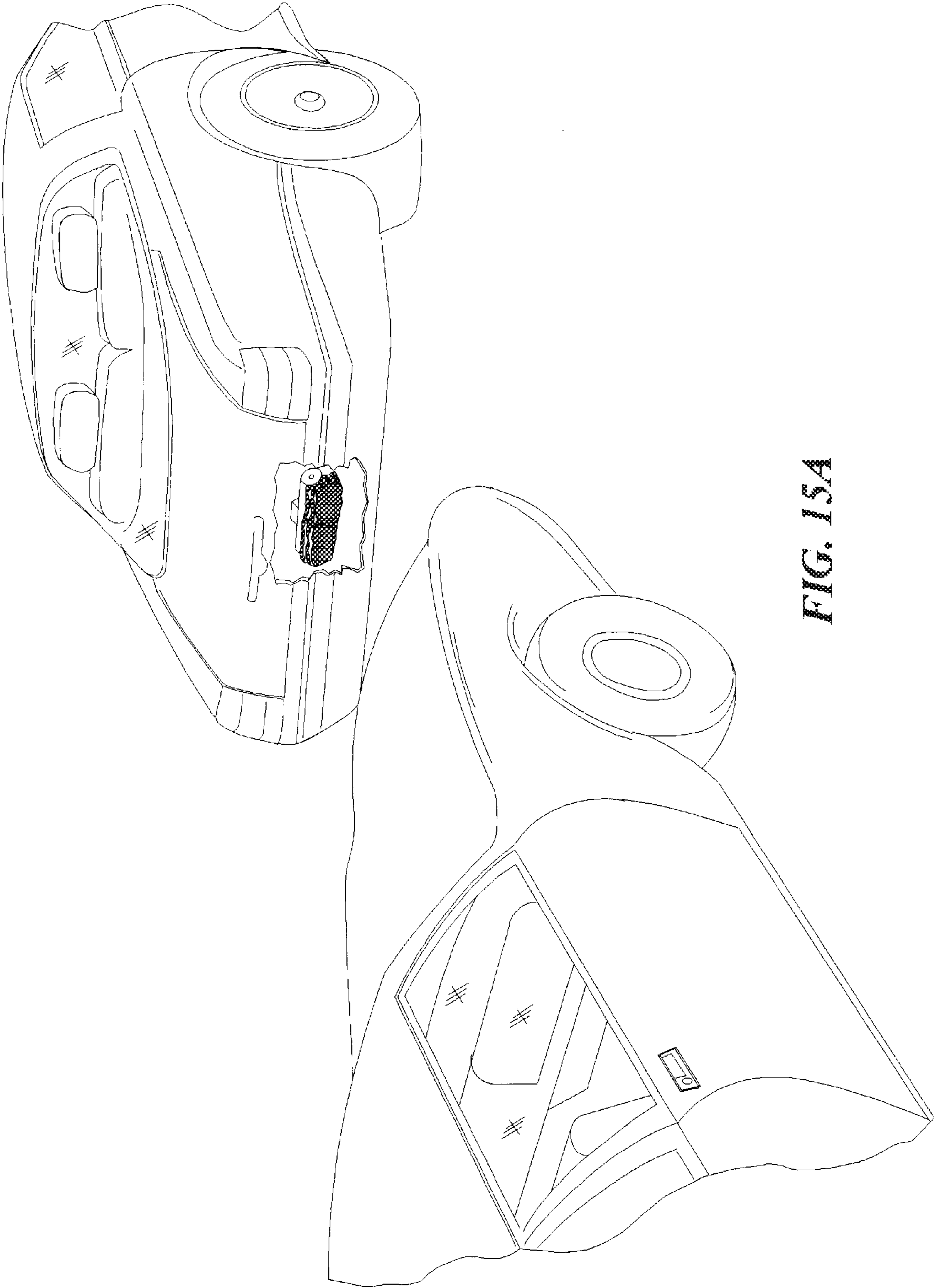

FIG. 15A

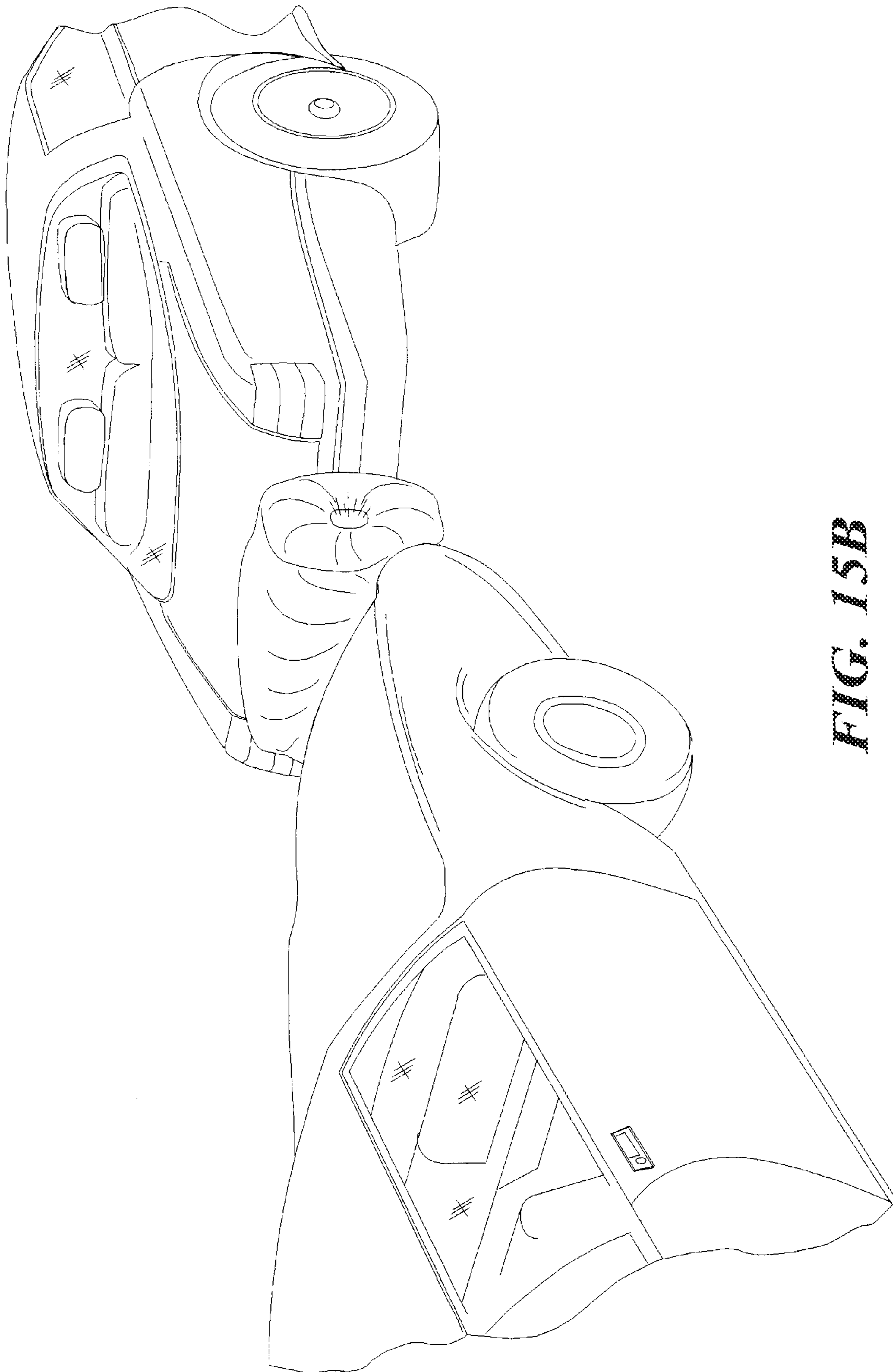

FIG. 15B

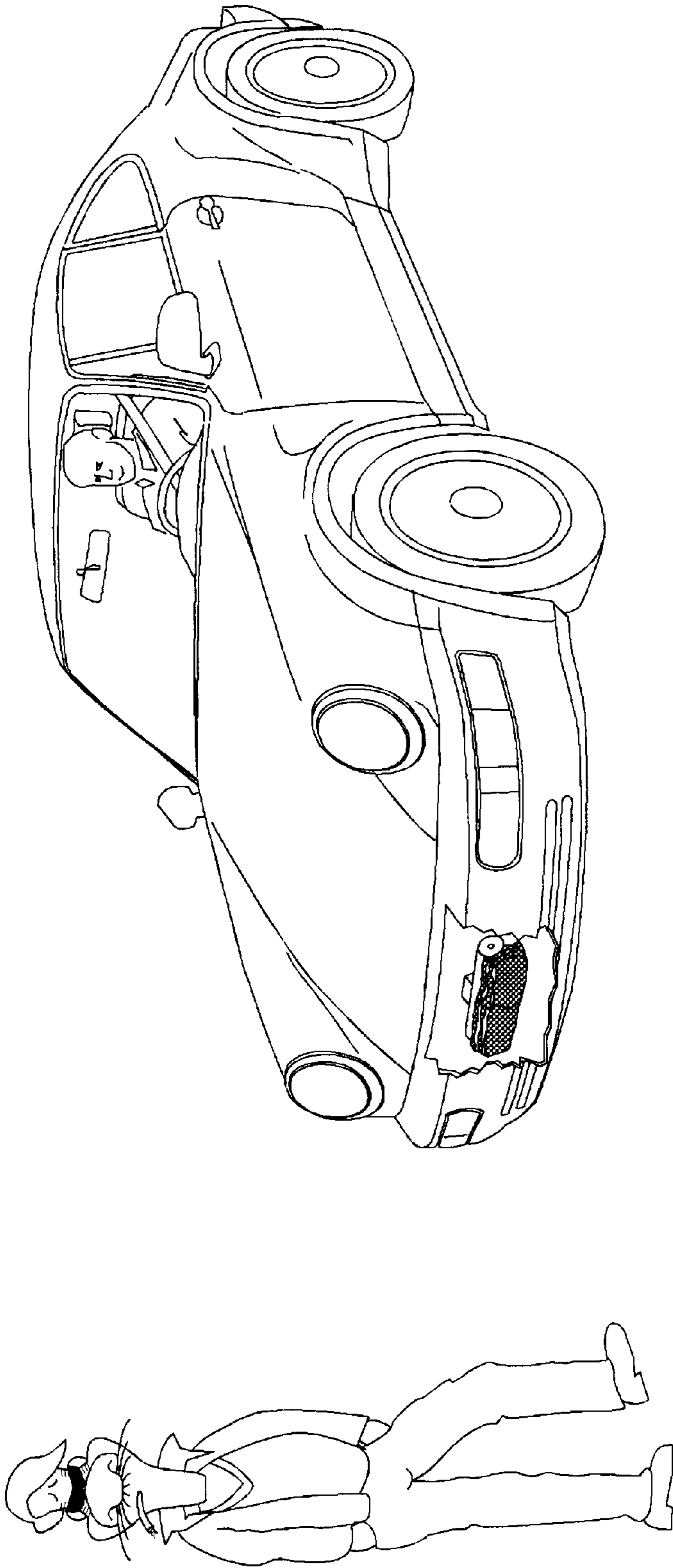

FIG. 16A

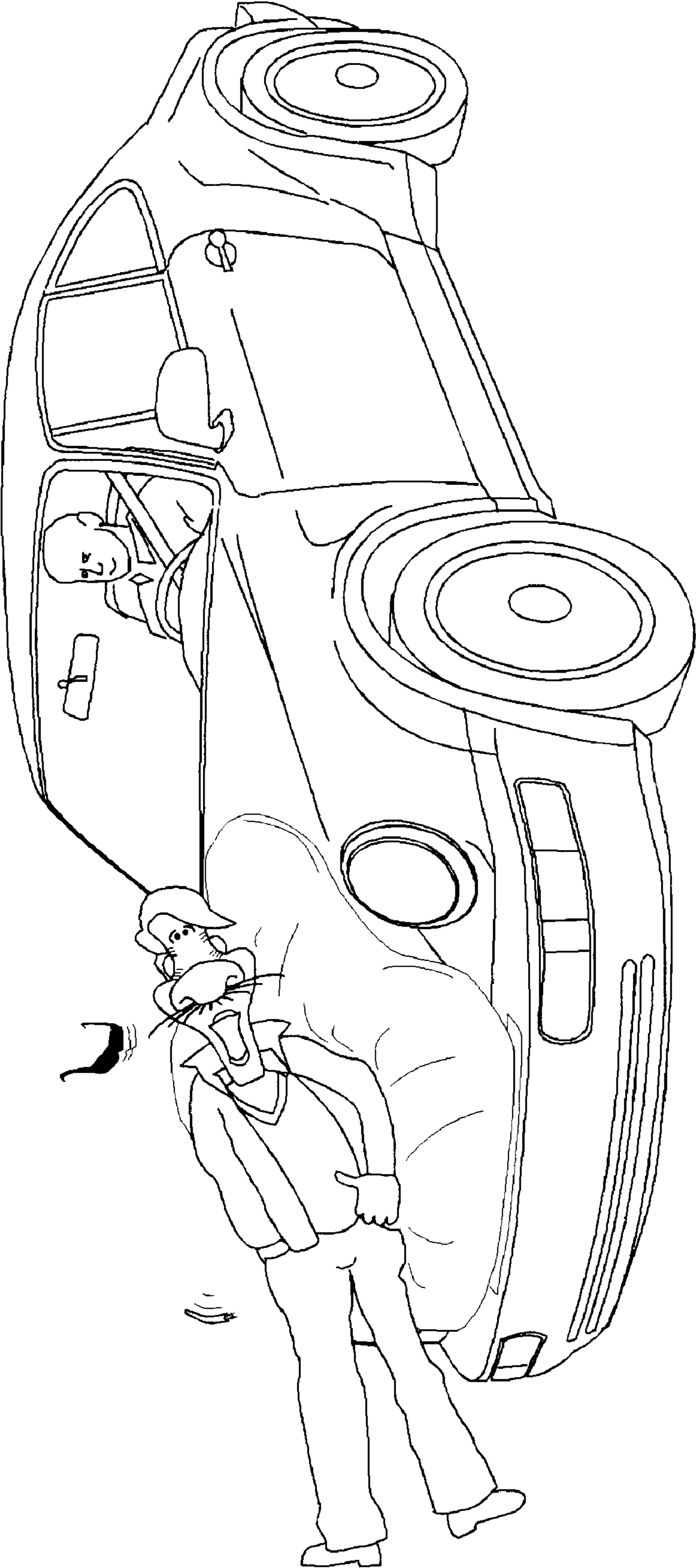

FIG. 16B

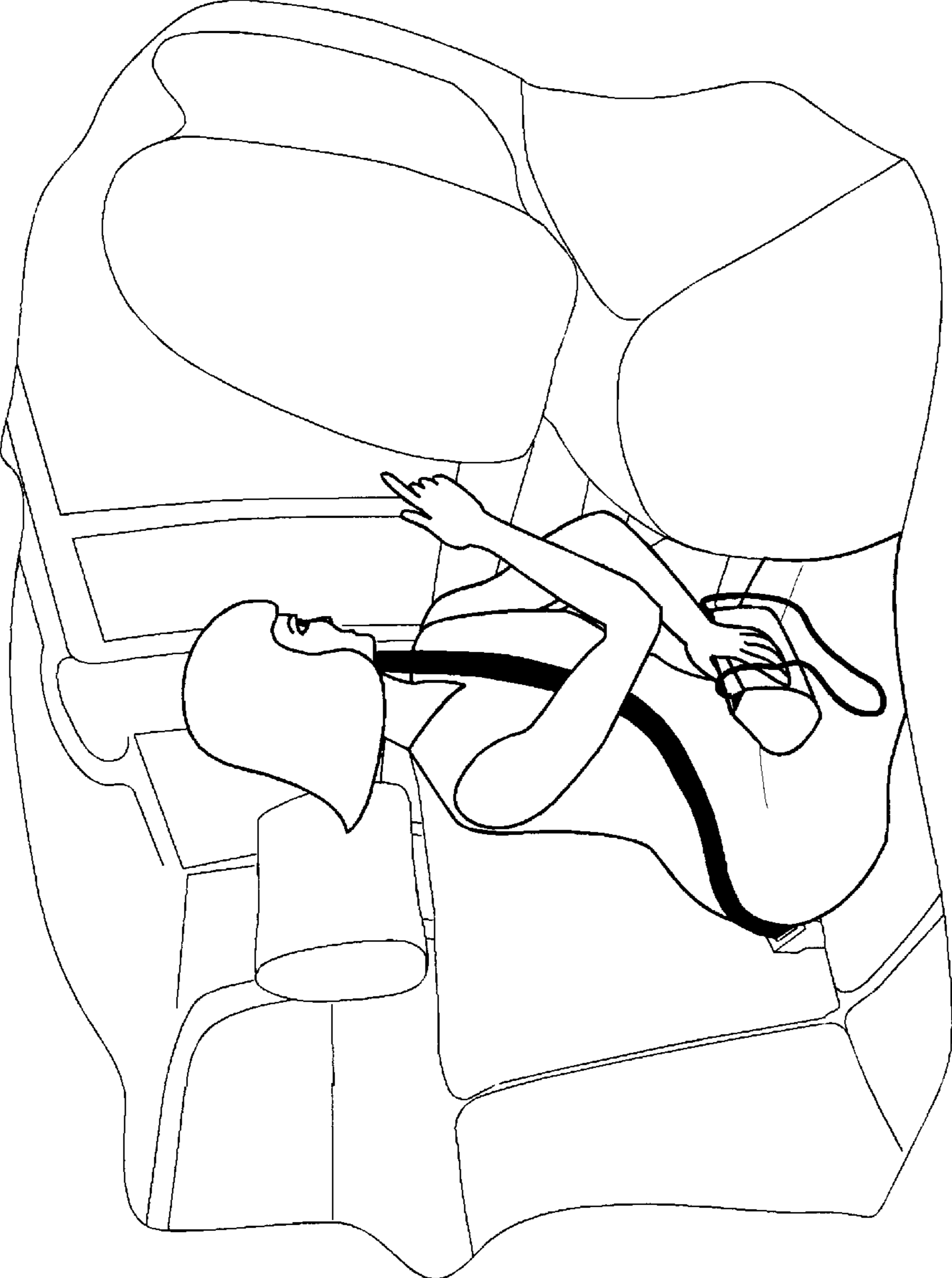

FIG. 17A

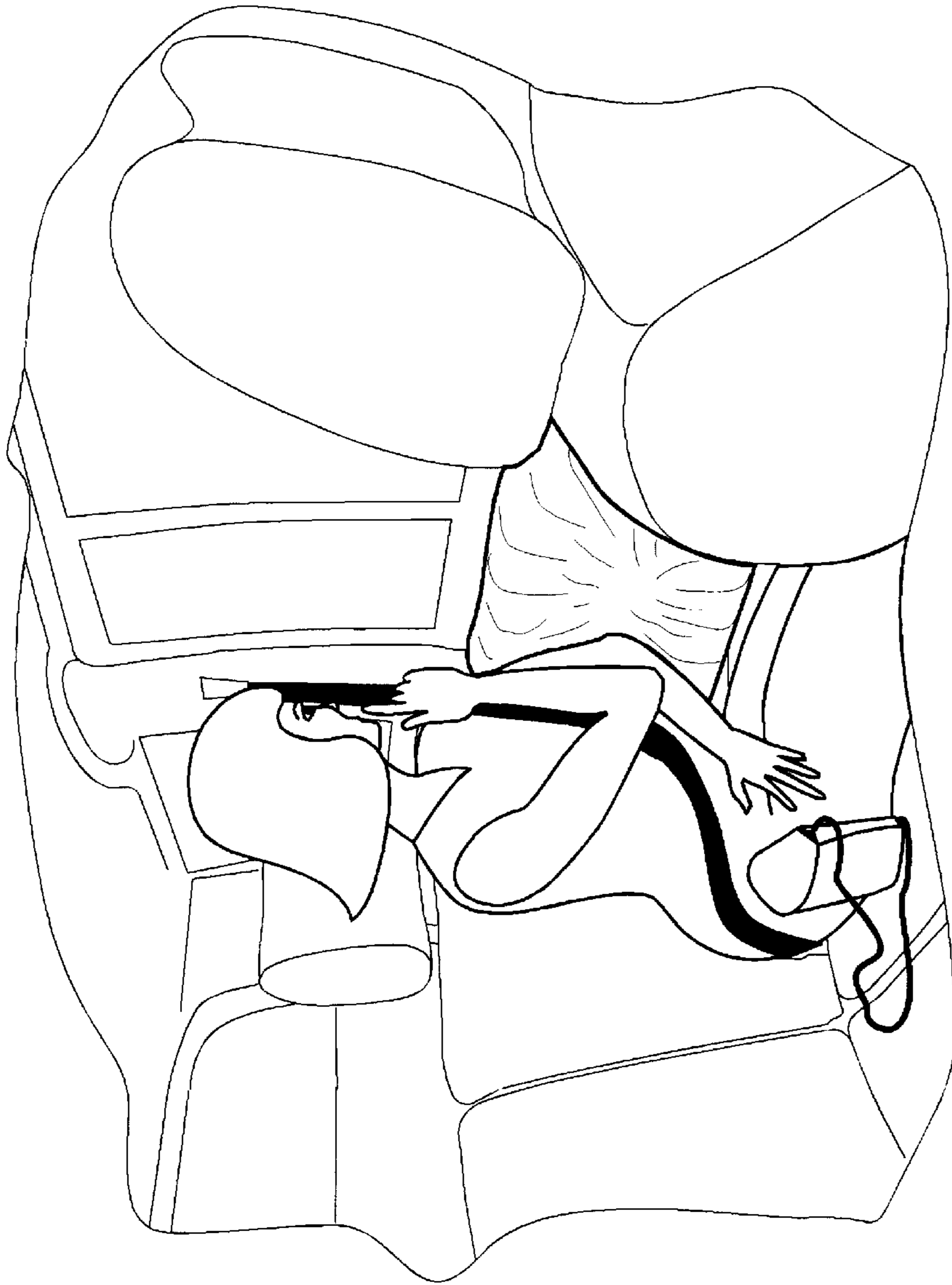

FIG. 17B

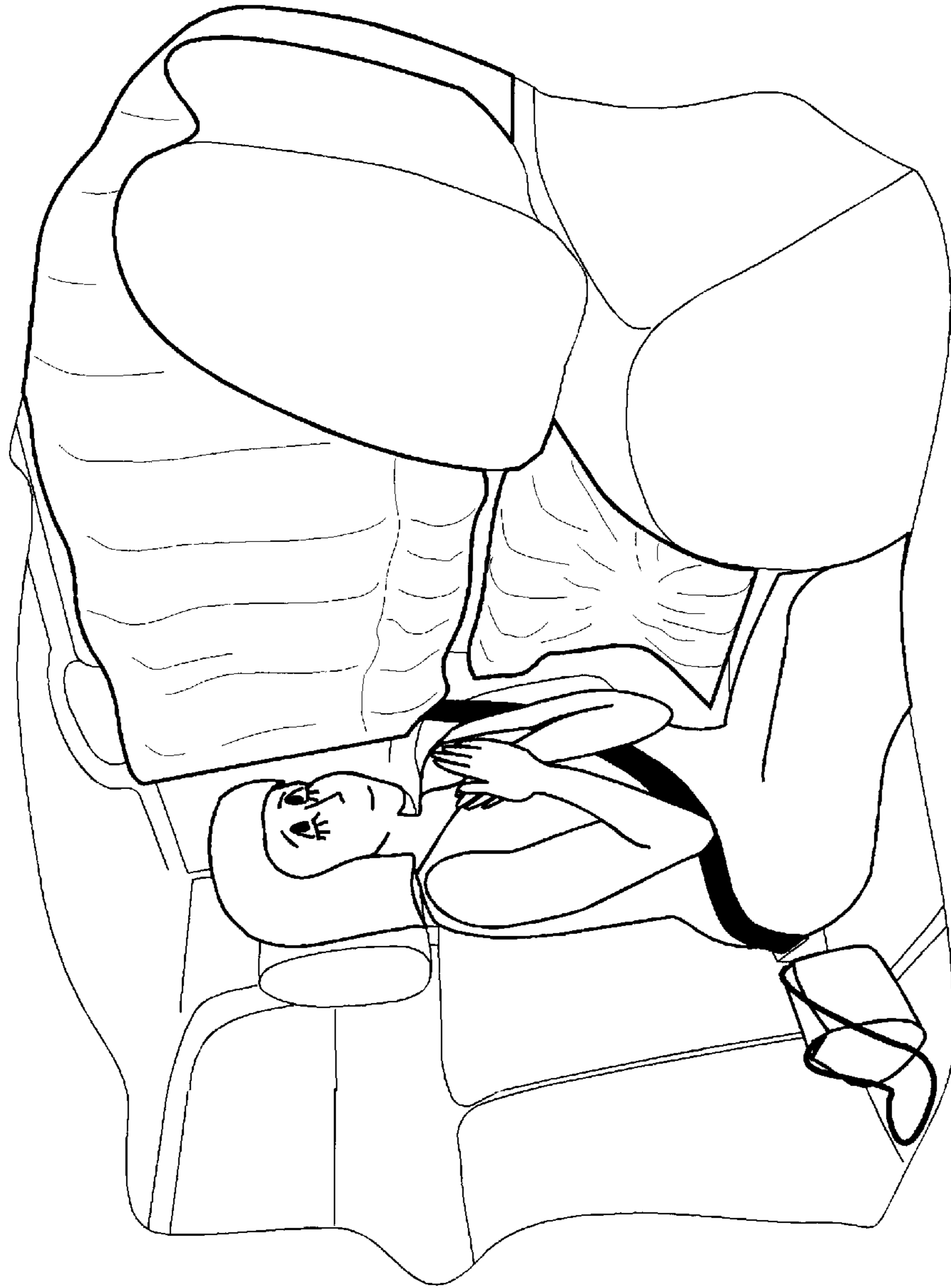

FIG. 17C

**COMBINED AIRBAG INFLATION AND
OCCUPANT DISPLACEMENT ENABLING
METHOD AND APPARATUS**

**CROSS REFERENCE TO RELATED
APPLICATIONS**

This application is a continuation-in-part of U.S. patent application Ser. No. 09/825,173 filed Apr. 3, 2001 now U.S. Pat. No. 6,623,033, which in turn is: 1) a continuation-in-part of U.S. patent application Ser. No. 09/024,085 filed Feb. 17, 1998, now U.S. Pat. No. 6,209,909, which is a continuation-in-part of U.S. patent application Ser. No. 08/247,760 filed May 23, 1994 now abandoned; and 2) a continuation-in-part of U.S. patent application Ser. No. 09/307,883 filed May 10, 1999, now U.S. Pat. No. 6,343,810, which is also a continuation-in-part of the '085 application. These applications are incorporated by reference herein in their entirety.

FIELD OF THE INVENTION

The present invention relates to combined airbag inflation and occupant displacement enabling method and apparatus in which an occupant is permitted to be displaced in conjunction with the inflation of the airbag.

The present invention also relates to airbag inflation control systems and methods and more particularly, to inflation control systems and methods including multiple crash sensors, each of which affects the accumulation of gas in an airbag.

BACKGROUND OF THE INVENTION

Frontal impacts were the number one killer of vehicle occupants in automobile accidents with about 16,000 fatalities each year. Side impacts were the second cause of automobile related deaths with about 8,000 fatalities each year. The number of fatalities in frontal impacts as well as side impacts has been decreasing due to the introduction of airbags and mandatory seatbelt use laws.

Several automobile manufacturers are now using side impact airbags to attempt to reduce the number of people killed or injured in side impacts. The side impact problem is considerably more difficult to solve in this way than the frontal impact problem due to the lack of space between the occupant and the side door and to the significant intrusion of the side door into the passenger compartment which typically accompanies a side impact.

Some understanding of the severity of the side impact problem can be obtained by a comparison with frontal impacts. In the Federal Motor Vehicle Safety Standard (FMVSS) 208 49 kph crash test which applies to frontal impacts, the driver, if unrestrained, will impact the steering wheel at about 30 kph. With an airbag and a typical energy absorbing steering column, there is about 40 cm to about 50 cm of combined deflection of the airbag and steering column to absorb this 30 kph difference in relative velocity between the driver and vehicle interior. Also, there is usually little intrusion into the passenger compartment to reduce this available space.

In the FMVSS 214 standard crash for side impacts, the occupant, whether restrained or not, is impacted by the intruding vehicle door also at about 30 kph. In this case there is only about 10 to 15 cm of space available for an airbag to absorb the relative velocity between the occupant and the vehicle interior. In addition, the human body is more vulnerable to side impacts than frontal impacts and there is usually significant intrusion into the passenger compart-

ment. A more detailed discussion of side impacts can be found in a paper by Breed et al, "Sensing Side Impacts", Society of Automotive Engineers Paper No. 940651, 1994, which is incorporated by reference herein.

5 Ideally, an airbag for side impact protection would displace the occupant away from the intruding vehicle door in an accident and create the required space for a sufficiently large airbag. Sensors used for side impact airbags, however, usually begin sensing the crash only at the beginning of the impact at which time there is insufficient time remaining to move the occupant before he is impacted by the intruding door. Even if the airbag were inflated instantaneously, it is still not possible to move the occupant to create the desired space without causing serious injury to the occupant. The problem is that the sensor that starts sensing the crash when the impact has begun, is already too late, i.e., once the sensor detects the crash, it is usually too late to properly inflate the airbag.

20 There has been discussion over the years in the vehicular safety community about the use of anticipatory sensors so that the side impact accident could be sensed before it occurs. Prior to 1994, this was not practical due to the inability to predict the severity of the accident prior to the impact. A heavy truck, for example, or a tree is a much more severe accident at low velocity than a light vehicle or motorcycle at high velocity. Further, it was not possible to differentiate between these different accidents with a high degree of certainty.

30 Once a sufficiently large airbag is deployed in a side impact and the driver displaced away from the door and the steering wheel, he will no longer be able to control the vehicle that could in itself cause a serious accident. It is critically important, therefore, that such an airbag not be deployed unless there is great certainty that the driver would otherwise be seriously injured or killed by the side impact. Anticipatory sensors have heretofore not been used because of their inability to predict the severity of the accident. As discussed more fully below, the present invention solves this problem and therefore makes anticipatory sensing practical. This permits side impact airbag systems that can save a significant percentage of the people who would otherwise be killed as well as significantly reducing the number and severity of injuries. This is accomplished through the use of pattern recognition technologies such as neural networks such as discussed in U.S. Pat. No. 5,829,782, incorporated by reference herein.

40 Neural networks, and more recently modular neural networks, are capable of pattern recognition with a speed, accuracy and efficiency heretofore not possible. It is now possible, for example, to recognize that the front of a truck or another car is about to impact the side of a vehicle when it is one to three meters or more away. This totally changes the side impact strategy since there is now time to inflate a large airbag and push the occupant out of the way of the soon to be intruding vehicle. Naturally, not all side impacts are of sufficient severity to warrant this action and therefore, there will usually be a dual inflation system as described in more detail below.

60 Although the main application for anticipatory sensors is in side impacts, frontal impact anticipatory sensors can also be used to identify the impacting object before the crash occurs. Prior to going to a full frontal impact anticipatory sensor system, neural networks can be used to detect many frontal impacts using data in addition to the output of the normal crash sensing accelerometer. Simple radar or acoustic imaging, for example, can be added to current acceler-

ometer based systems to give substantially more information about the crash and the impacting object than possible from the acceleration signal alone.

The side impact anticipatory sensor of this invention can use any of a variety of technologies including optical, radar (including noise radar, Micropower impulse radar, and ultra wideband radar), acoustical, infrared or a combination of these. The sensor system typically contains a neural network processor to make the discrimination however a simulated neural network, a fuzzy logic or other algorithm operating on a microprocessor can also be used.

With respect to prior art related to the subject matter of this application, reference is made to European Patent Publication No. 0 210 079 (Davis). Davis describes, inter alia, a radar system for use in connection with an airbag deployment apparatus to prevent injury to passengers when impact with an approaching object is imminent. Voltage level inputs representative of the distance between an object and the vehicle, the approach rate of the object with respect to the vehicle, the vehicle speed and driving monitor inputs, e.g., steering angles, turning rates and acceleration/deceleration, are all generated by appropriate detectors, weighted according to their importance to a normal vehicle operators' sensed safe or danger levels and then the weighted input voltages are summed to provide an "instantaneous voltage level". This instantaneous voltage level is compared with a predetermined voltage level and if the instantaneous voltage level falls within a predetermined safe zone, output signals are not produced. On the other hand, if the instantaneous voltage level falls outside of the safe zone, i.e., within a danger zone, then the system can be designed to initiate deployment of the airbag on the additional condition that the vehicle speed is above a predetermined level. For example, the system can be programmed to deploy the airbag when the vehicle speed is between 35 and 204 miles per hour at a time of about 0.2 second prior to impact thereby enabling the airbag sufficient time to fully inflate.

As far as structure, Davis includes a radar system that includes an antenna assembly, a signal-processing unit and an output monitor. Davis relies on a radar signal generated by an antenna in the antenna assembly and which causes a return signal to be produced upon reflection of the radar signal against the approaching object. The return signal is received by a transceiver to be processed further in order to determine the distance between the object and the vehicle and the rate the object is approaching the vehicle. The return signal from the radar signal generated by the antenna is a single pulse, i.e., a single pixel. The elapsed time between the emission of the radar signal by the antenna and the receipt of the return signal by the transceiver determines the distance between the object and the vehicle and based on the elapsed time for a series of radar signals generated at set intervals, it is possible to determine the approach rate of the object relative to the vehicle.

In operation, the approach rate of the object relative to the vehicle, the distance between the object and the vehicle, the vehicle speed as well as other driving parameters are converted to voltage levels. Davis then uses an algorithm to weigh the voltage levels and compare the voltage levels to predetermined conditions for which airbag deployment is desired. If the conditions are satisfied by the results of the algorithm operating on the weighted voltage levels, then the airbag is deployed. In one embodiment, by appropriate manipulation of the voltage levels, false-triggering of the airbag can be prevented for impacts with objects smaller than a motorcycle, i.e., the voltage corresponding to a motorcycle at a certain distance from the vehicle is smaller than the voltage corresponding to a truck, for example at that same distance.

Davis does not attempt to recognize any pattern of reflected waves, i.e., a pattern formed from a plurality of waves received over a set period of time, from many pixels simultaneously (light and CCDs) or of the time series of ultrasonic waves. A tree, for example can have a smaller radar reflection (lower voltage in Davis) than a motorcycle but would have a different reflected pattern of waves (as detected in the present invention). Thus, in contrast to the inventions described herein, Davis does not identify the object exterior of the vehicle based on a received pattern of waves unique to that object, i.e., each different object will provide a distinct pattern of reflected or generated waves. The radar system of Davis is incapable of processing a pattern of waves, i.e., a plurality of waves received over a period of time, and based on such pattern, identify the object exterior of the vehicle. Rather, Davis can only differentiate objects based on the intensity of the signal.

International Publication No. WO 86/05149 (Karr et al.) describes a device to protect passengers in case of a frontal or rear collision. The device includes a measurement device mounted in connection with the vehicle to measure the distance or speed of the vehicle in relation to an object moving into the range of the vehicle, e.g., another vehicle or an obstacle. In the event that prescribed values for the distance and/or relative speed are not met or exceeded, i.e., which is representative of a forthcoming crash, a control switch activates the protection and warning system in the vehicle so that by the time the crash occurs, the protection and warning system has developed its full protective effect. Karr et al. is limited to frontal crashes and rear crashes and does not appear to even remotely relate to side impacts. Thus, Karr et al. only shows the broad concept of anticipatory sensing in conjunction with frontal and rear crashes.

U.S. Pat. No. 4,966,388 (Warner et al.) relates to an inflatable system for side impact crash protection. The system includes a folded, inflatable airbag mounted within a door of the vehicle, an impact sensor also mounted within the door and an inflator coupled to the impact sensor and in flow communication with the airbag so that upon activation of the inflator by the impact sensor during a crash, the airbag is inflated.

U.S. Pat. No. 3,741,584 (Arai) shows a pressurized air container and two air lines leading to a protective air bag. An air line passes through a first valve which is controlled by an anticipatory sensor and the other air line passes through a second valve controlled by an impact detector. The purpose of having two sensors associated with different valves is to ensure that the protective bag will inflate even if one of the crash sensors does not operate properly.

U.S. Pat. No. 3,861,710 (Okubo) shows an airbag inflation system with a single airbag which is partially inflated based on a signal from an obstacle detecting sensor and then fully inflated based on a signal from an impact detecting sensor. The obstacle detecting sensor controls release of gas from a first gas supply source into the gas bag whereas the impact detecting sensor controls release of gas from a second gas supply source into the gas bag. The first gas supply source includes a first gas container filled with a proper volume of gas for inflating the gas bag to a semi-expanded condition, a first valve mechanism, a pipe between the first gas container and the first valve mechanism and a pipe between the first valve mechanism and the gas bag. The second gas supply source includes a second gas container filled with gas in a volume supplementing the volume of gas in the first gas container so that the contents of both gas containers will fully inflate the gas bag, a second valve mechanism, a pipe between the second gas container and the

second valve mechanism and a pipe between the first valve mechanism and the gas bag.

U.S. Pat. No. 3,874,695 (Abe et al.) shows an inflating arrangement including two inertia-responsive switches and coupled gas-generators. The gas-generators are triggered by the switches to inflate an airbag. The switches are both crash sensors and measured acceleration produced during the collision, and thus are not anticipatory sensors. The purpose of the two switches operative to trigger respective gas-generators is to enable the airbag to be inflated to different degrees. For example, if the crash involving the vehicle is a low speed crash, then only switch is actuated and gas-generated is triggered and the airbag will be inflated to part of its full capacity.

In U.S. Pat. No. 5,667,246 (Scholz et al.), there are two accelerometers, each of which provides a signal when the value of the increase in deceleration exceeds a respective threshold value. The signal from the accelerometer is set to a first ignition stage and through a delay member to a second ignition stage. The second ignition stage also receives as input, a signal from the accelerometer and provides an inflation signal only when it receives a signal from both accelerometers. In operation, when the accelerometer sends a signal it serves to partially inflate the airbag while full inflation of the airbag is obtained only by input from both accelerometers.

Taniguchi (JP 4-293641) describes an apparatus for detecting a body moving around another body, such as to detect a car thief moving around a car. The apparatus includes a detection section supported on a support toll to the roof of the car. Taniguchi states that the detection section may be based on an infrared, microwave or ultrasonic sensor.

OBJECTS AND SUMMARY OF THE INVENTION

It is an object of the present invention to provide a combined airbag inflation and occupant displacement enabling method and apparatus in which an occupant is permitted to be displaced in conjunction with the inflation of the airbag. In some cases, the occupant will be permitted to be displaced away from the airbag prior to impact.

It is another object of the present invention to provide a method and system for enabling or permitting displacement of a vehicle occupant upon inflation of an airbag so that the occupant is permitted to be displaced away from a site of an impact of an object into the vehicle.

Additional objects and advantages of this invention are:

1. To provide for the enhanced protection of occupants in side impacts by determining the probable severity of a pending accident and inflating an airbag prior to the impact to displace the occupant away from the vehicle door.

2. To provide for a method of identifying and classifying an object which is about to impact a vehicle.

3. To adapt pattern recognition techniques, and particularly neural networks (and modular neural networks), to permit the identification of objects external to an automotive vehicle and the determination of their approach speed and angle of potential collision.

4. To provide a method for assessing the probable severity of a pending accident based on the identification of the class of an object which is about to impact the vehicle plus stored information about the class of such objects such as its mass, strength and attachment to the earth.

5. To provide a method using an ultrasonic system for use in illuminating an object which is about to impact a vehicle

and using the reflection of the ultrasonic illumination in combination with a pattern recognition system to identify the object.

6. To determine the approach velocity of an object which is about to impact a vehicle.

7. To identify that a truck is about to impact a vehicle.

8. To identify that an automobile is about to impact a vehicle.

9. To identify that a vehicle is about to impact with a tree.

10. To provide a method using an electromagnetic wave system for use in illuminating an object which is about to impact a vehicle and using the reflection of the electromagnetic wave illumination in combination with a pattern recognition system to identify the object.

11. To provide a method using the passive infrared electromagnetic waves radiating from an object such as a motor vehicle in combination with a pattern recognition system to identify the object.

12. To provide a system for identifying an object which is about to impact a vehicle in a substantially side impact.

13. To provide a system for identifying an object which is about to impact a vehicle in a substantially frontal impact and/or rear impact.

14. To provide a system comprising a variable inflation airbag system where the control of the inflation of the airbag is determined by a prediction of the probable severity of an accident prior to the accident occurring.

15. To provide apparatus for inducing slack into a seatbelt in the event of a side impact to permit the occupant to be displaced sideways in the vehicle.

16. To provide a single airbag module for protection of the head and torso of an occupant in side impacts.

17. To provide a single airbag module for mounting in the seat back of a vehicle for the protection of the head and torso of an occupant in side impacts.

18. To provide a structure and method for enabling movement of the occupant and his seat in the event of a side, front or rear impact accident to increase the space between the occupant and the intruding object.

19. To provide a method using radar or laser radiation that has been modulated with noise or a code for providing the information leading to identification of an object.

20. To provide for an airbag to be deployed external to the vehicle in conjunction with an anticipatory sensor in side, frontal or rear impacts.

21. To provide a method using an ultrasonic wave system for use in illuminating an object which is about to impact a vehicle and using the reflection of the ultrasonic wave illumination in combination with a pattern recognition system to identify the object.

22. To provide a new and improved system and method for inflating an airbag based on information obtained by an anticipatory sensor and one or more additional crash sensors which provide information about the crash after the crash has begun and adjust the pressure in the airbag, if necessary.

Accordingly, some embodiments of the invention comprises an anticipatory crash sensor arrangement which provides information about an object such as a vehicle about to impact the resident vehicle, i.e., the vehicle in which the anticipatory crash sensor arrangement is situated, and causes inflation of one or more airbags. For example, internal and/or external airbags might be deployed.

One particular embodiment of the invention comprises an anticipatory sensor system which uses (i) a source of radiant

energy either originating from or reflected off of an object or vehicle which is about to impact the side of a target vehicle, plus (ii) a pattern recognition system to analyze the radiant energy coming from the soon-to-be impacting object or vehicle to (iii) assess the probable severity of a pending accident and (iv) if appropriate, inflate an airbag prior to the impact so as to displace the occupant away from the path of the impacting object or vehicle to create space required to cushion the occupant from an impact with the vehicle interior. Instead of or in addition to inflation of an airbag in the interior of the vehicle, an airbag may be inflated exterior of the vehicle to resist the force of the colliding object and thereby reduce the severity of the collision.

Although the primary area of application of some embodiments of this invention is for protection in side impacts, embodiments of the invention also provide added protection in frontal impacts by reducing the incidence of injury to out-of-position occupants by permitting a slower inflation of the airbag and displacing the occupant away from the airbag prior to the impact. Additionally, it can provide added protection in rear impacts by reducing the incidence of injury caused by impacts of the occupant's head with the headrest by repositioning the headrest adjacent the head of the occupant based on an anticipatory rear impact sensor.

In a combined airbag inflation and occupant displacement enabling system in accordance with the invention, a seat is movably attached to a floor pan of the vehicle for supporting an occupant, at least one airbag is arranged to be inflated to protect the occupant during a crash, an inflator or plurality of inflators is/are arranged to inflate the airbag(s), and an anticipatory sensor is coupled to the inflator and determines that a crash will occur based on data obtained prior to the crash. In this case, the inflator(s) is/are triggered by the anticipatory sensor to inflate the airbag(s). An occupant displacement system is coupled to the anticipatory sensor for displacing or enabling displacement of the occupant based on the determination of the impending crash by the anticipatory sensor. The occupant displacement system can be a system for introducing slack into the seatbelt prior to the impact to allow the occupant to move upon impact. The occupant displacement system can also be one or more positioning airbags, which are inflated prior to the crash to move or position a part of the occupant so that the occupant is in a better or correct position for deployment of a main protective airbag.

Instead of an anticipatory sensor, a crash sensor based on acceleration or crush or another property of the vehicle can be used. In this case, the crash sensor would determine that a crash is occurring requiring deployment of the airbag(s) after the crash has begun. Nevertheless, the seat can be designed to move automatically in order to optimize and maximize the deployment of the airbag(s) upon determination of a crash regardless of the manner in which the crash is determined.

Another crash sensor arrangement may be resident on the vehicle and provides information about the impact which may be used to adjust the pressure in the airbag based on the information about the impact, if any such adjustment is determined to be required. Adjustment of the pressure may entail increasing the pressure in the airbag by, directing additional gas into the airbag(s), or releasing a control amount and/or flow of gas from the airbag(s).

Preferred embodiments of the invention are described below and unless specifically noted, it is the applicant's intention that the words and phrases in the specification and claims be given the ordinary and accustomed meaning to

those of ordinary skill in the applicable art(s). If the applicant intends any other meaning, he will specifically state he is applying a special meaning to a word or phrase.

Likewise, applicant's use of the word "function" here is not intended to indicate that the applicant seeks to invoke the special provisions of 35 U.S.C. §112, sixth paragraph, to define his invention. To the contrary, if applicant wishes to invoke the provisions of 35 U.S.C. §112, sixth paragraph, to define his invention, he will specifically set forth in the claims the phrases "means for" or "step for" and a function, without also reciting in that phrase any structure, material or act in support of the function. Moreover, even if applicant invokes the provisions of 35 U.S.C. §112, sixth paragraph, to define his invention, it is the applicant's intention that his inventions not be limited to the specific structure, material or acts that are described in the preferred embodiments herein. Rather, if applicant claims his inventions by specifically invoking the provisions of 35 U.S.C. §112, sixth paragraph, it is nonetheless his intention to cover and include any and all structure, materials or acts that perform the claimed function, along with any and all known or later developed equivalent structures, materials or acts for performing the claimed function.

DEFINITIONS

Throughout the description herein, the term "approaching" when used as an object or vehicle approaching another will mean the relative motion of the object toward the vehicle having the anticipatory sensor system. Thus, in a side impact with a tree, the tree will be considered as approaching the side of the vehicle and impacting the vehicle. In other words, the coordinate system used in general will be a coordinate system residing in the target vehicle. The "target" vehicle is the vehicle that is being impacted. This convention permits a general description to cover all of the cases such as where (i) a moving vehicle impacts into the side of a stationary vehicle, (ii) where both vehicles are moving when they impact, or (iii) where a vehicle is moving sideways into a stationary vehicle, tree or wall.

"Pattern recognition" as used herein will generally mean any system which processes a signal that is generated by an object, or is modified by interacting with an object, in order to determine which one of a set of classes that the object belongs to. Such a system might determine only that the object is or is not a member of one specified class, or it might attempt to assign the object to one of a larger set of specified classes, or find that it is not a member of any of the classes in the set. Each class can include a single object or a single type of objects. The signals processed are generally electrical signals coming from transducers which are sensitive to either acoustic or electromagnetic radiation and, if electromagnetic, they can be either visible light, infrared, ultraviolet, radar or low frequency radiation as used in capacitive sensing systems.

A trainable or a trained pattern recognition system as used herein means a pattern recognition system which is taught various patterns by subjecting the system to a variety of examples. The most successful such system is the neural network. Not all pattern recognition systems are trained systems and not all trained systems are neural networks. Other pattern recognition systems are based on fuzzy logic, sensor fusion, Kalman filters, correlation as well as linear and non-linear regression. Still other pattern recognition systems are hybrids of more than one system such as neural-fuzzy systems.

“To identify” as used herein will mean to determine that the object belongs to a particular set or class. The class may be one containing all trucks of a certain size or weight, one containing all trees, or all walls. In the case where a particular vehicle type is to be recognized, the set or class will contain only a single element, the particular vehicle type to be recognized.

BRIEF DESCRIPTION OF THE DRAWINGS

The present invention will be further understood from the following description with reference to the drawings in which:

FIG. 1 is an overhead view of a vehicle about to be impacted in the side by an approaching vehicle showing a wave transmitter part of the anticipatory sensor system;

FIG. 1A is a perspective view of a vehicle about to impact the side of another vehicle showing the location of the various parts of an anticipatory sensor system of this invention;

FIG. 2 is an overhead view of a vehicle about to be impacted in the front by an approaching vehicle showing a wave transmitter part of the anticipatory sensor system;

FIG. 3A a plan front view of the front of a car showing the headlights, radiator grill, bumper, fenders, windshield, roof and hood;

FIG. 3B a plan front view of the front of a truck showing the headlights, radiator grill, bumper, fenders, windshield, roof and hood;

FIG. 4 is an overhead view of a vehicle about to be impacted in the side by an approaching vehicle showing an infrared radiation emanating from the front of the striking vehicle and an infrared receiver part of the anticipatory sensor system;

FIG. 5 is a side view with portions cutaway and removed of a dual inflator airbag system with two airbags with one airbag lying inside the other;

FIG. 6 is a perspective view of a seatbelt mechanism illustrating a device to release a controlled amount of slack into seatbelt allowing an occupant to be displaced;

FIG. 7 is a front view of an occupant being restrained by a seatbelt having two anchorage points on the driver's right side where the one is released allowing the occupant to be laterally displaced during the crash;

FIG. 7A is an expanded view of the release mechanism within the circle designated 7A in FIG. 7;

FIG. 7B is a view of the apparatus of FIG. 7A within the circle designated 7B and rotated 90 degrees showing the release mechanism;

FIG. 8 is a front view of an occupant being restrained by a seatbelt integral with seat so that when seat moves during a crash with the occupant, the belt also moves allowing the occupant to be laterally displaced during the crash;

FIG. 9A is a front view of an occupant being restrained by a seatbelt and a linear airbag module attached to the seat back to protect entire occupant from his pelvis to his head;

FIG. 9B is a view of the system of FIG. 9A showing the airbag in the inflated condition;

FIG. 10A is a front view of an occupant being restrained by a seatbelt and where the seat is displaced toward vehicle center by the deploying airbag in conjunction with other apparatus;

FIG. 10B is a front view of an occupant being restrained by a seatbelt and where the seat is rotated about a vertical axis in conjunction with other apparatus;

FIG. 10C is a front view of an occupant being restrained by a seatbelt and where the seat is rotated about a longitudinal axis in conjunction with other apparatus;

FIG. 11A is a perspective view with portions cutaway and removed of a vehicle about to impact the side of another vehicle showing an airbag stored within the side door of the target vehicle prior to being released to cushion the impact of the two vehicles;

FIG. 11B is a view of the apparatus of FIG. 11A after the airbag has deployed;

FIG. 12 is a schematic drawing of a variable inflation inflator system in accordance with the invention using two inflators;

FIG. 13 is a schematic drawing of a variable inflation inflator system in accordance with the invention using a single inflator and a variable outflow port or vent;

FIG. 14A shows a situation where a vehicle equipped with an externally deployable airbag for frontal impact protection is about to impact another vehicle;

FIG. 14B shows the condition of the vehicles of FIG. 14A at impact;

FIG. 15A shows a situation where a vehicle equipped with an externally deployable airbag for rear impact protection is about to be impacted by another vehicle;

FIG. 15B shows the condition of the vehicles of FIG. 15A at impact;

FIG. 16A shows a situation where a vehicle equipped with an externally deployable airbag for frontal impact protection is about to impact a pedestrian;

FIG. 16B shows the condition of the vehicle and pedestrian of FIG. 16A at impact; and

FIGS. 17A, 17B and 17C show one use of pre-positioning airbags in accordance with the invention wherein a passenger is shown leaning against a door in FIG. 17A, a pre-positioning airbag deploys to move the passenger away from the door as shown in FIG. 17B and a side curtain airbag is deployed when the passenger has been moved away from the door as shown in FIG. 17C.

DETAILED DESCRIPTION OF THE PREFERRED EMBODIMENTS

Referring to the accompanying drawings wherein like reference numerals refer to the same or similar elements, FIG. 1 is an overhead view of a vehicle 110 about to be impacted in the side by an approaching vehicle 120 where vehicle 110 is equipped with an anticipatory sensor system in accordance with the invention including a wave transmitter 130 which transmits waves 132 toward the approaching vehicle 120. A perspective view of vehicle 110 is shown in FIG. 1A and illustrates the transmitter 130 connected to an electronic module 140 (this connection being symbolized by the dotted lines between the transmitter 130 and the module 140 which may represent a wire). Module 140 is mounted in the B-pillar and contains circuitry means 142 to drive the transmitter 130 to transmit waves and circuitry means 144 coupled to wave receivers 134, 136, which receive the returned waves and convert the same into signals, to process the signals from receivers 134 and 136 representative of the returned waves. Circuitry 144 preferably contains a neural computer or computer with resident pattern recognition algorithm 145 that performs the pattern recognition determination based on signals from the receivers 134 and 136. Receivers 134, 136 are positioned are either side of transmitter 130, although the presence of two such receivers and the positioning on both sides of the transmitter

130 is not critical or essential to the invention and different amounts of receivers and different relative positions of receivers to the transmitter are encompassed within the scope and spirit of invention.

In a preferred implementation, transmitter **130** is an ultrasonic transmitter operating at a frequency of approximately 40 kHz, although other frequencies could be used. Similarly, receivers **134** and **136** are ultrasonic receivers or transducers and receive the reflected ultrasonic waves from vehicle **120**.

A detailed discussion of pattern recognition technology as applied to the monitoring and identification of occupants and objects within a vehicle is discussed in detail in Breed et al. (U.S. Pat. No. 5,829,782) incorporated herein by reference. Although the application herein is for the identification of objects exterior to the vehicle, many of the same technologies, principles and techniques are applicable.

An example of such a pattern recognition system using neural networks using sonar is discussed in two papers by Gorman, R. P. and Sejnowski, T. J. "Analysis of Hidden Units in a Layered Network Trained to Classify Sonar Targets", *Neural Networks*, Vol.1. pp 75-89, 1988, and "Learned Classification of Sonar Targets Using a Massively Parallel Network", *IEEE Transactions on Acoustics, Speech, and Signal Processing*, Vol. 36, No. 7, July 1988.

A "trained" pattern recognition system as used herein will mean a pattern recognition system that is trained on data representing different operating possibilities. For example, the training data may constitute a number of sets of a signal from receiver **134** represented the returned waves received thereby, a signal from receiver **136** representing the returned waves received thereby and one or more properties of the approaching object, e.g., its form or shape, size or weight, identity, velocity, breadth and relative distance. Once trained, the trained pattern recognition system will be provided with the signals from receivers **134,136** and categorize the signals that would lead to a determination by the system of the property or properties of the approaching object, e.g., its size or identity.

Some examples follow:

In a passive infrared system, a detector receives infrared radiation from an object in its field of view, in this case the approaching object is most likely another vehicle, and processes the received infrared radiation radiating from the vehicle's engine compartment. The anticipatory sensor system then processes the received radiation pattern to determine the class of vehicle, and, along with velocity information from another source, makes an assessment of the probable severity of the pending accident and determines if deployment of an airbag is required. This technology can provide input data to a pattern recognition system but it has limitations related to temperature. The sensing of a non-vehicle object such as a tree, for example, poses a particular problem. The technology may also fail to detect a vehicle that has just been started especially if the ambient temperature is high. Nevertheless, for use in the identification of approaching vehicles the technology can provide important information especially if it is used to confirm the results from another sensor system.

In a laser optical system, the transmitter **130** comprises an infrared laser beam which is used to momentarily illuminate an object as illustrated in FIG. 1 where transmitter **130** is such a laser beam transmitter. In some cases, a charge coupled device (a type of TV camera), or a CMOS optical sensor array, is used to receive the reflected light and would be used as one or both of the receivers **132** and **134**. The

laser can either be used in a scanning mode, or, through the use of a lens, a cone of light can be created which covers a large portion of the object. In each case, a pattern recognition system, as defined above, is used to identify and classify the illuminated object and its constituent parts. The scanning implementation of the laser system has an advantage that the displacement of the object can be calculated by triangulation of the direction of the return light from the transmitted light providing the sensor and transmitter as displaced from one another. This system provides the most information about the object and at a rapid data rate. Its main drawback is cost which is considerably above that of ultrasonic or passive infrared systems and the attenuation that results in bad weather conditions such as heavy rain, fog or snow storms. As the cost of lasers comes down in the future, this system will become more competitive. The attenuation problem is not as severe as might be expected since the primary distance of concern for anticipatory sensors as described here is usually less than three meters and it is unlikely that a vehicle will be operated with a visibility of only a few meters. If the laser operates in the infrared region of the spectrum, the attenuation from fog is less than if it is operated in the visible part of the spectrum.

Radar systems have similar properties to the laser system discussed above with the advantage that there is less attenuation in bad weather. The wavelength of a particular radar system can limit the ability of the pattern recognition system to detect object features smaller than a certain size. This can have an effect in the ability of the system to identify different objects and particularly to differentiate between different truck and automobile models. It is also more difficult to use radar in a triangulation system to obtain a surface map of the illuminated object as can be done with an infrared laser.

The ultrasonic system is the least expensive and potentially provides less information than the laser or radar systems due to the delays resulting from the speed of sound and due to the wave length which is considerably longer than the laser systems. The wavelength limits the detail that can be seen by the system. In spite of these limitations, as shown in the above referenced Breed et al. patent (U.S. Pat. No. 5,829,782), ultrasonics can provide sufficient timely information to permit the position and velocity of an approaching object to be accurately known and, when used with an appropriate pattern recognition system, it is capable of positively determining the class of the approaching object. One such pattern recognition system uses neural networks and is similar to that described in the papers by Gorman et al. and in the rear facing child seat recognition system referenced and described in the Breed et al. patent referenced above.

A focusing system, such as used on some camera systems, could be used to determine the position of an approaching vehicle when it is at a significant distance away but is too slow to monitor this position just prior to a crash. This is a result of the mechanical motions required to operate the lens focusing system. By itself, it cannot determine the class of the approaching object but when used with a charge coupled, or CMOS, device plus infrared illumination for night vision, and an appropriate pattern recognition system, this becomes possible.

From the above discussion, it can be seen that the addition of sophisticated pattern recognition means to any of the standard illumination and/or reception technologies for use in a motor vehicle permits the development of an anticipatory sensor system which can identify and classify an object prior to the actual impact with the vehicle.

The application of anticipatory sensors to frontal impact protection systems is shown in FIG. 2 which is an overhead

view of a vehicle **110** about to be impacted in the front by an approaching vehicle **120**. In a similar manner as in FIG. **1**, a transmitter **160** transmits waves **162** toward vehicle **120**. These waves are reflected off of vehicle **120** and received by receiving transducers **164** and **166** positioned on either side of transmitter **160**.

FIG. **3A** illustrates the front of an automobile **310** and shows preferred locations for transmitting transducer **160** and receiving transducers **164** and **166**, i.e., the transmitter **160** below the grill and the receivers **164,166** on each side of the grill. FIG. **3A** also illustrates the distinctive features of the vehicle which cause a distinct pattern of reflected waves which will differ from that of a truck **320**, for example, as shown in FIG. **3B**. In some pattern recognition technologies, the researcher must determine the distinctive features of each object to be recognized and form rules that permit the system to recognize one object from another of a different class. An alternative method is to use artificial neural network technology wherein the identification system is trained to recognize different classes of objects. In this case, a training session is conducted where the network is presented with a variety of objects and told to which class each object belongs. The network then learns from the training session and, providing a sufficient number and diversity of training examples are available, the network is able to categorize other objects which have some differences from those making up the training set of objects. The system is quite robust in that it can still recognize objects as belonging to a particular class even when there are significant differences between the object to be recognized and the objects on which the system was trained.

Once a neural network has been sufficiently trained, it is possible to analyze the network and determine the "rules" which the network evolved. These rules can then sometimes be simplified or generalized and programmed as a fuzzy logic algorithm. Alternately, a neural computer can be programmed and the system implemented on a semiconductor chip as available from Motorola.

The anticipatory sensor system must also be able to determine the distance, approach velocity and trajectory of the impacting object in addition to the class of objects to which it belongs. This is easily done with acoustic systems since the time required for the acoustic waves to travel to the object and back determine its distance based on the speed of sound. With radar and laser systems, the waves usually need to be modulated and the phase change of the modulation determined in order to determine the distance to the object as discussed in more detail in U.S. Pat. No. 5,653,462 (Breed et al.), incorporated herein by reference in its entirety. Since the same distance measurement techniques are used here as in the two above referenced patent applications, they will not be repeated here.

There is a radar chip on the market that permits the distance determination based on the time required for the radar waves to travel to the object and back. This technology was developed by Amerigon Inc. of Burbank, Calif. and is being considered for other automotive applications such as constant distance cruise control systems and backing-up warning systems.

FIG. **3A** is a plan front view of the front of a car showing the headlights, radiator grill, bumper, fenders, windshield, roof and hood and other objects which reflect a particular pattern of waves whether acoustic or electromagnetic. Similarly, FIG. **3B** is a plane frontal view of the front of a truck showing the headlights, radiator grill, bumper, fenders, windshield, roof and hood illustrating a significantly differ-

ent pattern. Neural network pattern recognition techniques using software available from NeuralWare Corp. of Pittsburgh, Pa. can be used to positively classify trucks as a different class of objects from automobiles and further to classify different types of trucks giving the ability to predict accident severity based on truck type and therefore likely mass, as well as velocity. Other software tools are also commercially available for creating neural networks and fuzzy logic systems capable of recognizing patterns of this type.

In FIG. **4**, an overhead view of a vehicle **110** about to be impacted in the side by an approaching vehicle **120** in a perpendicular direction is illustrated where infrared radiation **432** is radiating from the front of the striking vehicle **120**. An infrared receiver **434** arranged on the side of vehicle **110** receives this radiation for processing as described above.

The anticipatory sensor system described and illustrated herein is mainly used when the pending accident will cause death or serious injury to the occupant. Since the driver will no longer be able to steer or apply the brakes to the vehicle after deployment of an airbag which is sufficiently large to protect him in serious accidents, it is important that this large airbag not be deployed in less serious accidents where the driver's injuries are not severe. Nevertheless, it is still desirable in many cases to provide some airbag protection to the driver. This can be accomplished as shown in FIG. **5** which is a side view with portions cutaway and removed of a dual inflator airbag system, shown generally as **500**, with an airbag **505** which in essence comprises two separate airbags **510** and **520** with one airbag **510** lying inside the other airbag **520**. An optional variable outflow port or vent **544** is provided in connection with airbag **520** in a manner known in the art. Although a single inflator having a variable inflation rate capability can be used, FIG. **5** illustrates the system using two discrete inflators **530** and **540** which may be triggered independently or together to thereby provide a variable inflation rate of the airbag **505**. Inflator **540** and associated airbag **520** are controlled by the anticipatory sensor system described herein and the inflator **530** and associated airbag **510** could also be initiated by the same system. In a less severe accident, inflator **530** can be initiated also by the anticipatory sensor without initiating inflator **540** or, alternately, inflator **530** could be initiated by another sensor system such as described U.S. Pat. No. 5,231,253 to Breed et al., incorporated herein by reference in its entirety. Each inflator **530,540** contains standard materials therefor, e.g., an initiator, a gas propellant.

Thus, the variable inflation rate inflator system for inflating the airbag **505** comprises inflators **530,540** for producing a gas and directing the gas into the airbag **505**, and crash sensors (as described in any of the embodiments herein or otherwise available) for determining that a crash requiring an airbag will occur or is occurring and, upon the making of such a determination, triggering the inflator(s) **530** and/or **540** to produce gas and direct the gas into the airbag **505** to thereby inflate the same at a variable inflation rate, which depends on whether only inflator **530** is triggered, only inflator **540** is triggered or both inflators **530,540** are triggered (see FIG. **12**).

More particularly, the inflator **540** may be associated with an anticipatory crash sensor to be triggered thereby and the inflator **530** may be associated with the anticipatory crash sensor or another different sensor, such as one which detects the crash only after it has occurred. In this manner, inflator **540** will be triggered prior to inflator **530** and inflator **530**, if triggered, will supply an additional amount of gas into the airbag **505**.

Although the description above is based on the use of two inflators, the same result can be obtained through the use of a variable outflow port or vent **550** from the airbag **505** (additional information about a variable outflow port or vent from the airbag **505** is provided in the current assignee's U.S. Pat. No. 5,748,473 (FIG. 9) incorporated by reference in its entirety herein). A schematic drawing of an embodiment including a single inflator and a variable outflow port or vent from the airbag is shown in FIG. 13. This has the advantage that only a single inflator is required and the decision as to how much gas to leave in the airbag can be postponed.

As shown in FIG. 13, a first crash sensor **526** is an anticipatory sensor and determines that a crash requiring deployment of the airbag **505** is about to occur and initiates deployment prior to the crash of substantially concurrent with the crash. Thereafter, a second crash sensor **528**, which may be an anticipatory crash sensor (possibly even the same as crash sensor **526**) or a different type of crash sensor, e.g., a crush sensor or acceleration based crash sensor, provides information about the crash before it occurs or during its occurrence and controls vent control means **542** to adjust the pressure in the airbag. The vent control means **542** may be a valve and control system therefor which is situated or associated with a conduit connected to the outflow port or vent **544** at one end and at an opposite end to any location where the pressure is lowered than in the airbag whereby opening of the valve causes flow of gas from the airbag through the conduit and valve.

Specifically, the vent control means **542** adjust the flow of gas through the port or vent **544** in the airbag **505** (FIG. 5) to enable removal of a controlled amount of gas from the airbag **505** and/or enable a controlled flow of gas from the airbag **505**. In this manner, the airbag **505** can be inflated with the maximum pressure prior to or substantially concurrent with the crash and thereafter, once the actual crash occurs and additional, possibly better, information is known about the severity of the crash, the pressure in the airbag is lowered to be optimal for the particular crash (and optimally in consideration of the position of the occupant at that moment).

In the alternative, the vent control means **542** can be controlled to enable removal of gas from the airbag **505** concurrent with the generation of gas by the inflator **540** (and optionally **530**). In this manner, the rate at which gas accumulates in the airbag **505** is controllable since gas is being generated by inflator **540** (and optionally inflator **530**, dependent on the anticipated severity of the crash) and removed in a controlled manner via the outflow port or vent **544**.

Referring again to FIG. 5, when the large airbag **520** is inflated from the driver's door, for example, it will attempt to displace the occupant away from the vehicle door. If the seatbelt attachment points do not also move, the occupant will be prevented from moving by the seatbelt and some method is required to introduce slack into the seatbelt or otherwise permit him to move. Such a system is shown in FIG. 6 which is a perspective view of a seatbelt mechanism where a device releases a controlled amount of slack into seatbelt allowing an occupant to be displaced.

The seatbelt spool mechanism incorporating the slack inducer is shown generally as **600** in FIG. 6 and includes a seatbelt **602** only a portion of which is shown, a housing **604** for the spool mechanism, a spool **606** containing several wound layers of seatbelt material **602**. Also attached to the spool **606** is a sheave **608** upon which is wound a cable **610**.

Cable **610** is connected to a piston **622** of an actuator **620**. Piston **622** is positioned within a cylinder **624** of the actuator **620** so that a space is defined between a bottom of the cylinder **624** and the piston **622** and is able to move within cylinder **624** as described below.

When the anticipatory sensor system decides to deploy the airbag, it also sends a signal to the seatbelt slack inducer system of FIG. 6. This signal is in the form of an electric current which passes through a wire **632** and is of sufficient magnitude to initiate pressure generating means for generating a pressure in the space between the piston **622** and the cylinder **624** to force the piston **622** in a direction to cause the sheave **608** to rotate and thus the spool **606** to rotate and unwind the seatbelt therefrom. More specifically, the electric current through wire **632** ignites a squib **634** arranged in connection with a propellant housing **630**. Squib **634** in turn ignites propellant **636** situated within housing **630**. Propellant **636** burns and produces gas which pressurizes chamber **638** defined in housing **630**, which is in fluid communication with the space at a bottom **623** of the cylinder **624** between the cylinder **624** and the piston **622**, and pressurizes cylinder **624** below piston **622**. When subjected to this pressure, piston **622** is propelled upward within cylinder **624**, pulling cable **610** and causing sheave **608** to rotate in the counter-clockwise direction as shown in FIG. 6. This rotation causes the spool **606** to also rotate causing the belt **602** to spool off of spool **606** and thereby inducing a controlled amount of slack into the belt and thus permitting the occupant to be displaced to the side. In some cases, it may not be necessary to control the amount of slack introduced into the seatbelt and a simpler mechanism which releases the seatbelt can be used.

An alternate system is shown in FIG. 7 which is a frontal view of an occupant **710** being restrained by a seatbelt **720** having two anchorage points **730** and **732** on the right side of the driver where the one **730** holding the belt at a point closest to the occupant **710** is released allowing the occupant **710** to be laterally displaced to the left in the figure during the crash. A detail of the release mechanism **730** taken within the circle **7A** is shown in FIG. 7A.

The mechanism shown generally as **730** comprises an attachment bolt **744** for attaching the mechanism to the vehicle tunnel sheet-metal **740**. Bolt **744** also retains a metal strip **742** connected to member **737**. Member **737** is in turn attached to member **739** by means of explosive bolt assembly **736**. Member **739** retains the seatbelt **720** by virtue of pin **738** (FIG. 7B). A stop **752** placed on belt **720** prevents the belt from passing through the space between pin **738** and member **739** in the event that the primary anchorage point **732** fails. Upon sensing a side impact crash, a signal is sent through a wire **734** which ignites explosive bolt **736** releasing member **737** from **739** and thereby inducing a controlled amount of slack into the seatbelt.

In some implementations, the vehicle seat is so designed that in a side impact, it can be displaced or rotated so that both the seat and occupant are moved away from the door. In this case, if the seatbelt is attached to the seat, there is no need to induce slack into the belt as shown in FIG. 8. FIG. 8 is a frontal view of an occupant **810** being restrained by a seatbelt **820** integral with seat **830** so that when seat **830** moves during a crash with the occupant **810**, the seatbelt **820** and associated attachments **842**, **844**, **846** and **848** also move with the seat allowing the occupant **810** to be laterally displaced during the crash.

Various airbag systems have been proposed for protecting occupants in side impacts. Some of these systems are

mounted within the vehicle seat and consist of a plurality of airbag modules when both the head and torso need to be protected. An illustration of the use of this module is shown in FIG. 9A, which is a frontal view of an occupant **910** being restrained by a seatbelt **920** and a linear airbag module **930**, of the type described in the aforementioned patent application, including among other things a housing **935** and an inflatable airbag **932** arranged therein and associated inflator means. This linear module is mounted by appropriate mounting means to the side of seat back **940** to protect the entire occupant **910** from his pelvis to his head. An anticipatory sensor may be provided as described above, i.e., one which detects that a side impact requiring deployment of the airbag is required based on data obtained prior to the crash and initiates inflation of the airbag by the inflator means in the event a side impact requiring deployment of the airbag is detected prior to the start of the impact.

Airbag module **930** may extend substantially along a vertical length of the seat back **940** as shown, and the airbag **932** in the housing **935** may be attached to the seat-back **940** or integral therewith.

A view of the system of FIG. 9A showing the airbag **932** in the inflated condition is shown in FIG. 9B.

In FIG. 10A, a frontal view of an occupant **1010** being restrained by a seatbelt **1020** and wherein the seat **1050** is displaced toward vehicle center, i.e., away from the side and side door of the vehicle, by deploying airbag **1040** is shown. In this case, the seatbelt **1020** is attached to the seat **1050** as described above with reference to FIG. 8. In this case, rail mechanisms **1062** and **1064** permit the seat to be displaced away from the door under the force produced by the deploying airbag **1040**. Rail mechanisms **1062,1064** may include a first member having a guide channel and a second member having a projection positioned for movement in the guide channel of the first member.

To enable displacement of the seat **1050** and thus the occupant **1010** away from the airbag-deploying structure, the door in the illustrated embodiment, by the force exerted on the seat **1050** upon inflation of the airbag **1040**, the rail mechanisms **1062,1064** are preferably oriented in any direction not perpendicular to the deploying direction of the airbag, i.e., not parallel to the side of the vehicle in the illustrated example. Otherwise, if the orientation of the rails mechanisms **1062,1064** was parallel to the side of the vehicle and the airbag **1040** deployed in a direction perpendicular to the side of the vehicle, the seat **1050** would not be moved away from the side door. Obviously, to provide for the fastest possible displacement away from the airbag-deploying structure, the rail mechanisms **1062,1064** are oriented perpendicular to the airbag-deploying structure, which may also be parallel to the deploying direction of the airbag **1040**.

Thus, for an airbag mounted in the steering wheel or dashboard and designed to deploy in a frontal impact, the rail mechanisms **1062,1064** would optimally be oriented in the longitudinal direction of the vehicle. For an airbag mounted in the side as shown in FIG. 10A, the rail mechanisms would optimally be oriented in a direction perpendicular to the longitudinal direction of the vehicle.

In FIG. 10B, a frontal view of an occupant **1010** being restrained by a seatbelt **1020** and wherein the seat **1050** is rotated toward vehicle center, i.e., substantially about an axis perpendicular to a horizontal plane of the vehicle, by deploying airbag **1040** is shown. In this case, the seatbelt **1020** is attached to the seat **1050** as described above with reference to FIG. 8. In this case, rail mechanisms **1066** and mounting

locations **1068** permit the seat to be rotated away from the door under the force produced by the deploying airbag **1040**. This figure is shown with the occupant rotated 90 degrees from initial position, this amount of rotation may be difficult for all vehicles. However, some degree of rotation about the vertical axis is possible in most vehicles. Rail mechanisms **1066** may include a first member having a curved guide channel and a second member having a projection positioned for a curving or rotational movement in the guide channel of the first member.

As shown in FIG. 10B, the seat **1050** is rotated in a clockwise direction so that the occupant is facing inward during the rotation. The rail mechanism **1066** can be designed to rotate the seat **1050** counterclockwise as well as along any rotational path. For example, in a frontal impact, it might be desirable to rotate the occupant toward the adjacent side door to enable the occupant to exit the vehicle via the side door and/or be extracted from the vehicle via the side door. Otherwise, if the occupant were to be rotated inward, the seat back would be interposed between the occupant and the side door and might hinder egress from the vehicle and extraction of the occupant from the vehicle after the crash.

In an alternate case where there is sufficient space for the occupant's legs and feet, the seat **1050** can be rotated as shown in FIG. 10C, i.e., substantially about an axis oriented in a longitudinal direction of the vehicle. The rotating mechanism comprises a hinged assembly of two plates **1052** and **1054**, with plate **1052** attached to the vehicle floorpan and plate **1054** attached to the vehicle seat **1050**. The two plates are held together by a suitable clamp **1058** which is released by the sensor at the same time the airbag is deployed.

Other means for tilting the seat **1050** or enabling rotation of the seat **1050** about the vehicle yaw axis or roll axis are also envisioned to be within the scope of the invention.

The displacement of the seat **1050** by the force exerted by the airbag upon its inflation or deployment is thus very useful for increasing the distance between the occupant and the site of the impact, whether it is a side impact, frontal impact or even a rear-impact.

Displacement of the seat **1050** could also be useful in rollover situations where the occupant would want to be displaceable in a particular direction depending on the nature of the rollover. Thus, a rollover sensor would replace the crash sensor, either the anticipatory crash sensor or the actual acceleration or crush sensors described above. Upon detection of a rollover, some action would be taken to inflate an airbag and enable movement of the seat when the force exerted by the inflation of the airbag is effective on the seat. One or more of the seat displacement enabling system could be incorporated into the vehicle so that one or more of these systems activated upon the detection of a rollover, depending on which motion of the seat and occupant would best benefit the occupant.

Many of the techniques disclosed above will not work well for some of today's small vehicles. They are applicable in vans, sport utility vehicles, some small trucks and some minivans. For other vehicles, an externally deployed airbag may be the only assured solution.

Once an anticipatory sensor system is in place, it becomes possible to consider deployment of an airbag external to the vehicle. This possibility has appeared in the automobile safety literature in the past but it has not been practical until the impacting object can be identified and/or an assessment of the probable severity of the accident made. For prior art

systems, it has not been possible to differentiate between a plastic sand-filled construction barrier or a cardboard box, for example, neither of which would result in a serious accident (and thus airbag deployment would not be required) and a concrete pillar, tree or wall which would likely result in a serious accident (and thus airbag deployment would be required). With the development of the pattern recognition systems described herein, and in the above referenced patents and patent applications, this problem has been solved and the use of an external airbag now becomes feasible.

Assessment of the probable severity of the impact is preferably accomplished using the different pattern recognition techniques disclosed herein, whereby the identity, size or another property of the object about to impact the vehicle (or with which the vehicle is about to impact) is determined using the pattern recognition technique and the identification or determination of the object's size is considered before initiating deployment of the airbag. In this manner, upon appropriate training of the pattern recognition algorithm, if the vehicle is about to strike a large cardboard box, it will be identified as such and airbag deployment will not occur. On the other hand, if the vehicle is about to strike a large truck, it will be identified as such and airbag deployment will occur. In the prior art, no such differentiation was made about the object involved in the impact based on remote sensing, i.e., sensing prior to impact.

Such a system adapted for side impact protection is shown in FIG. 11A which is a perspective view with portions cutaway and removed of a vehicle 1110 about to be impacted in the side by another vehicle 1120. An airbag module is shown generally as 1180 mounted to the side door of the vehicle 1110 prior to inflation of an airbag 1182 arranged in the airbag module 1180. A portion of the side door of vehicle 1110 has been cutaway to permit viewing of the airbag module 1180. The vehicle 1110 contains a strong support beam 1160 arranged in a longitudinal direction of the vehicle at least partially within the side door(s) 1155 and which provides a reaction surface along with the vehicle door 1155 for the airbag. Upon initiation by the anticipatory sensor, a deployment door, not shown, is opened in an external door panel 1156 by any of a number of methods such as pyrotechnically, permitting the airbag 1182 to emerge from the vehicle door 1155 as shown in FIG. 11B, the airbag 1182 being inflated by inflator means responsive to the detection by the anticipatory sensor that a side impact requiring deployment of the airbag is required.

Through a system such as illustrated in FIGS. 11A and 11B, the accident can be substantially cushioned prior to engagement between the vehicle and the impacting object. By this technique, an even greater protection can be afforded the occupant especially if an internal airbag is also used. This has the further advantage that the occupant may not have to be displaced from behind the steering wheel and thus the risk to causing an accident is greatly reduced. It also may be the only system which will work with some of today's small vehicles. The anticipatory sensor system could determine whether the impact is one which requires deployment of only the external airbag 1182 or one which requires deployment of both the internal airbag and the external airbag 1182.

Although the description of FIGS. 11A and 11B relates to side impact protection, it is understood that the same concept can be used for frontal impacts and rear impacts and rollover situations. That is, the location of the airbag 1182 is not limited to locations along the side of the vehicle, nor to the side door.

An anticipatory sensor system can thus be installed all around the vehicle, with multiple externally deployable

airbags, whereby in use, when a determination is made that an object is about to impact the vehicle, only the airbag(s) which will inflate between the vehicle and the object, and which will cushion the impact, is/are inflated.

For example, FIGS. 14A and 14B show an externally deployable airbag mounted at the front of a vehicle so as to provide frontal impact protection. The airbag may be mounted in a housing or module in and/or proximate the bumper, fender, grille, or other part at the front of the vehicle. By using anticipatory sensing and/or exterior object identification as discussed above, the airbag is deployed prior to or at the moment of impact.

FIGS. 15A and 15B show an externally deployable airbag mounted at the rear of a vehicle so as to provide rear impact protection. The airbag may be mounted in a housing or module in and/or proximate the bumper or another part at the rear of the vehicle. By using anticipatory sensing and/or exterior object identification as discussed above, the airbag is deployed prior to or at the moment of impact.

FIGS. 16A and 16B show an externally deployable airbag mounted at the front of a vehicle for a situation where pedestrian protection is obtained. The airbag may be mounted in a housing or module in and/or proximate the bumper, fender, grille, or other part at the front of the vehicle. By using anticipatory sensing and/or exterior object identification as discussed above, the airbag is deployed prior to or at the moment of impact to protect the pedestrian. It can be seen by comparing FIG. 14B and FIG. 16B that the airbag for pedestrian protection deploys over the hood of the vehicle instead of in front of the vehicle. In a similar manner, an airbag for pedestrian impact protection at the rear of a vehicle would be arranged to deploy over the trunk instead of rearward as shown in FIG. 15B.

In this embodiment, the anticipatory sensor system can be designed to sense an approaching pedestrian or animal and deploy the airbag to cushion the pedestrian's or animal's impact against the vehicle.

It is envisioned that the features of the side impact protection systems, rear impact protection systems, frontal impact protection systems, and pedestrian impact protection systems can be used interchangeably to the extent possible. Thus, features of the side impact protection systems can be used for rear, frontal and pedestrian impact protection.

In another embodiment of the invention using an anticipatory sensor system, a deploying airbag is used to pre-position the occupant. That is, an airbag is arranged and designed to move only a part of the occupant, not necessarily the seat, so as to make room for deployment of another airbag. For example, a shoulder or thorax airbag could be deployed based on a determination from an anticipatory sensor system that a crash is imminent and a determination from an interior monitoring system that the occupant's head is resting against the window. The deploying shoulder or thorax airbag would serve to push the occupant's head away from the window, making room for the deployment of a side curtain airbag between the window and the person's head. Such pre-positioning airbags could be strategically arranged in the vehicle to move different parts of an occupant in a specific direction and then deployed based on the position the occupant is in prior to the impact to change the occupant's status of "out-of-position" vis-à-vis airbag deployment to "in-position".

An example of the use of pre-positioning airbags in accordance with the invention is shown in FIGS. 17A, 17B and 17C wherein a passenger is shown leaning against a door in FIG. 17A, a pre-positioning airbag deploys from the

door to move the passenger away from the door as shown in FIG. 17B and a side curtain airbag is deployed, e.g., from a location above the window, when the passenger has been moved away from the door as shown in FIG. 17C. Ideally, the passenger or a part thereof would be moved a sufficient distance to enable effective deployment of the side curtain airbag while preventing injury.

Using a pre-positioning airbag, the pre-positioning airbag is preferably deployed before the main airbag or side curtain airbag. Deployment of the pre-positioning airbag could be initiated based on anticipatory sensing of an object about to impact the vehicle, and in conjunction with an interior monitoring system or occupant position sensor which would sense the position of the occupant or a part thereof and determine the need to move the occupant or a part thereof to enable deployment of the main airbag or side curtain airbag, or at least to make the deployment more effective.

In general terms, disclosed above is an inflator system for inflating an airbag which comprises gas inflow means for inflating the airbag with gas, vent means for controlling removal of gas from the airbag, a first anticipatory crash sensor for determining that a crash requiring deployment of the airbag will occur based on data obtained prior to the crash and, upon the making of such a determination, directing the gas inflow means to inflate the airbag, and a second crash sensor for determining that a crash requiring deployment of the airbag will occur or is occurring and, upon the making of such a determination, controlling the vent means to enable the removal of gas from the airbag whereby the pressure in the airbag is changed by the removal of gas therefrom enabled by the vent means.

The gas inflow means may be in the form of an inflator which is activated to produce gas and release the gas through conduits into the interior of the airbag. The gas inflow means can also be in the form of a tank of pressurized gas and a valve in a conduit leading from the tank to the interior of the airbag whereby opening of the valve causes flow of gas from the tank into the airbag. Any other type of structure or method which serves to cause accumulation of gas in the interior of the airbag can also be used as gas inflow means in accordance with the invention. The gas inflow means can also constitute multiple inflators which are independently activated based on, the severity of the anticipated crash. In this case, one inflator would be activated for a minor or average crash whereas for a more severe crash, two or more inflators would be activated thereby increasing the flow of gas into the airbag and the inflation rate and/or pressure therein. Each inflator could be controlled by the same or a different crash sensor.

The vent means may be in the form of a variable outflow port or vent integral with the airbag, e.g., a flap built in an exterior surface of the airbag and providing a regulatable conduit between the interior of the airbag and exterior of the airbag (regulatable both with respect to the amount of gas flowing therethrough and/or the rate of gas flowing therethrough). The vent means may also be in the form of a conduit leading from the interior of the airbag to the exterior of the airbag and having a regulatable valve in the conduit whereby regulated opening of the valve causes removal of gas from the interior of the airbag.

The airbag may be, but is not required to be, a side airbag arranged to inflate between the occupant and the side door. Regardless of the direction of the crash which will cause deployment of the airbag, it is beneficial to provide some form of occupant displacement permitting means arranged in connection with the seat for permitting the occupant to be

displaced away from the airbag mounting surface upon inflation of the airbag and thereby increase the space between the occupant and the airbag mounting surface. Thus, if the airbag is a side airbag mounted in the side door, it is beneficial to enable displacement of the occupant away from the side door. Such occupant displacement permitting or enabling means may be in the form of some structure which introduces slack into the seatbelt in conjunction with the deployment of the airbag or a mechanism by which the seat can be moved or is actually moved away from the side door, e.g., tilted inward.

The airbag can also be arranged to inflate to protect a rear-seated occupant and to this end, would be arranged in a back portion of the seat, attached to the back portion of the seat and/or integral with the back portion of the seat.

For any positioning and use, the airbag can be arranged in a housing of an airbag module. The airbag module could extend substantially along a vertical length of the back portion of the seat for a side airbag.

Another embodiment of the inflator system comprises inflator means for releasing a gas into the at least one airbag, a first anticipatory crash sensor for determining that a crash requiring deployment of the airbag will occur based on data obtained prior to the crash and, upon the making of such a determination, triggering the inflator means to release gas into the airbag, and a second crash sensor for determining that a crash requiring deployment of the airbag will occur or is occurring and, upon the making of such a determination, changing the rate at which gas accumulates in the airbag. To this end, the second crash sensor is structured and arranged to control outflow of gas from the airbag. Outflow of gas from the airbag may be controlled via a variable outflow port.

A method for inflating an airbag comprises the steps of making a first determination by means of an anticipatory crash sensor that a crash requiring deployment of the airbag will occur based on data obtained prior to the crash and, upon the making of such a determination, inflating the airbag, and making a second, separate determination by means of a second crash sensor that a crash requiring deployment of the airbag will occur or is occurring and, upon the making of such a determination, changing the rate at which gas accumulates in the airbag. The rate at which gas accumulates in the airbag may be changed by enabling and regulating outflow of gas from the airbag.

In accordance with another embodiment of the invention, a vehicle comprises one or more inflatable airbags deployable outside of the vehicle, an anticipatory sensor system for assessing the probable severity of an impact involving the vehicle based on data obtained prior to the impact and initiating inflation of the airbag(s) in the event an impact above a threshold severity is assessed, and an inflator coupled to the anticipatory sensor system and the airbag for inflating the airbag when initiated by the anticipatory sensor system. The airbag may be housed in a module mounted along a side of the vehicle, in a side door of the vehicle, at a front of the vehicle or at a rear of the vehicle.

The anticipatory sensor system may comprise at least one receiver for receiving waves or energy and a pattern recognition system, e.g., data storage medium embodying a pattern recognition algorithm or neural network, for analyzing the received waves or energy or data representative of the received waves or energy to assess the probable severity of the impact. The pattern recognition system may also be designed to identify an object from which the waves or energy have been emitted or generated, in which case, the

assessment of the probable severity of the impact is at least partially based on the identification of the object. The pattern recognition system can also be designed to determine at least one property of an object from which the waves or energy have been emitted or generated, in which case, the assessment of the probable severity of the impact is at least partially based on the determined at least one property of the object.

Also disclosed herein is an airbag passive restraint system for protecting an occupant adjacent the door in a side impact which comprises an airbag arranged to inflate between the door and the occupant and a side impact anticipatory sensor for determining that an accident requiring deployment of the airbag is about to occur prior to the accident. The sensor is arranged to receive waves generated by, modified by or reflected from an object about to impact the vehicle resulting in the accident and comprises identifying and determining means for identifying the object based on a pattern of the received waves and determining whether the identified object will cause an accident requiring deployment of the airbag. The system also includes an inflator coupled to the sensor for inflating the airbag if the sensor determines that an accident requiring deployment of the airbag is about to occur. The identifying and determining means may comprise a neural network trained on data of possible patterns of received waves in conjunction with an identification of the object the received waves have been generated by, modified by or reflected from. In the alternative, the identifying and determining means may comprise a fuzzy logic algorithm or a rule based pattern recognition algorithm. The sensor may be arranged to receive electromagnetic waves or acoustic waves.

Another disclosed embodiment of a system for triggering deployment of an airbag passive restraint system in anticipation of an accident between the vehicle and an object approaching the vehicle comprises transmitter means arranged on the vehicle for sending waves toward the object, receiver means arranged on the vehicle for receiving modified or reflected waves from the object and producing a signal representative of the waves, identifying and determining means for identifying the object based on a pattern of the received waves and determining whether the identified object will cause an accident requiring deployment of the passive restraint system and triggering means responsive to the identifying and determining for initiating deployment of the passive restraint system if the identifying and determining means determines that an accident requiring deployment of the passive restraint system is about to occur. The transmitter means may be arranged to transmit electromagnetic waves, such as radar waves, or ultrasonic waves. The identifying and determining means may comprise a neural network trained on data of possible patterns of received waves in conjunction with an identification of the object the received waves have been modified by or reflected from, a fuzzy logic algorithm or a rule based pattern recognition algorithm. The transmitter means may also comprise a laser transmitter and the receiver means comprise a charge coupled device or CMOS sensing array.

Still another disclosed embodiment of a system for triggering deployment of an airbag passive restraint system in anticipation of an accident between the vehicle and an object approaching the vehicle comprises receiver means for receiving electromagnetic waves generated, reflected or modified by the object, identifying and determining means for identifying the object based on a pattern of the received waves and determining whether the identified object will cause an accident requiring deployment of the passive

restraint system and triggering means responsive to the identifying and determining means for initiating deployment of the passive restraint system if the identifying and determining means determines that an accident requiring deployment of the passive restraint system is about to occur. The receiver means may be arranged to receive light waves or infrared waves. As in the embodiments discussed above, the identifying and determining means may comprise a neural network trained on data of possible patterns of received waves in conjunction with an identification of the object the received waves have been generated, reflected or modified by, a fuzzy logic algorithm or a rule based pattern recognition algorithm. The receiver means may comprise a charge-coupled device or CMOS sensing array.

Also disclosed is a method for controlling deployment of a passive restraint system in anticipation of an accident with an approaching object which comprises the steps of mounting at least one receiver on the vehicle to receive waves generated by, modified by or reflected from an object exterior of the vehicle, conducting training identification tests on a plurality of different classes of objects likely to be involved in a vehicular accident, each of the tests comprising the steps of receiving waves generated by, modified by or reflected from the object by means of the receiver(s) and associating an object class with data from each test, and generating an algorithm from the training test results, associated object classes and an indication as to whether deployment of the passive restraint system is necessary such that the algorithm is able to process information from the received waves from the receiver(s), identify the class of the object and determine whether deployment of the passive restraint system is necessary. During operational use, a plurality of waves generated by, modified by or reflected off an object exterior of the vehicle are received by means of the receiver(s) and the algorithm is applied using the received waves as input to identify the object exterior of the vehicle and determine whether deployment of the passive restraint system is necessary. At least one transmitter may be mounted on the vehicle to transmit waves toward the object exterior of the vehicle such that the waves are reflected off or modified by the object exterior of the vehicle and received by the receiver(s).

In some implementations, the sensor system may include a variable inflation rate inflator system for inflating the airbag(s). Such an inflator system comprises inflator means for releasing a gas into the airbag(s), a first anticipatory crash sensor for determining that a crash requiring an airbag will occur based on data obtained prior to the crash and, upon the making of such a determination, triggering the inflator means to release gas into the airbag(s) to thereby inflate the same at a first inflation rate, a second crash sensor for determining that a crash requiring an airbag will occur or is occurring and, upon the making of such a determination, affecting the inflator means such that an additional quantity of gas is released thereby into the airbag(s) to thereby inflate the same at a second inflation rate greater than the first inflation rate. The inflator means may comprise first and second inflators structured and arranged to produce gas and direct the gas into the airbag(s) and which are independent of one another such that the first inflator may be triggered by the first anticipatory sensor without triggering of the second inflator and the second inflator may be triggered by the second crash sensor without triggering of the first inflator.

In conjunction with the variable inflation rate inflator system described above, a method for providing a variable inflation rate of the airbag(s) is also envisioned. Such a method would entail determining that a crash requiring an

airbag will occur based on data obtained prior to the crash, e.g., by an anticipatory sensor, and upon the making of such a determination, triggering an inflator to release gas into the airbag(s) to thereby inflate the same at a first inflation rate, determining in another manner that a crash requiring an airbag will occur or is occurring and, upon the making of such a determination, affecting the inflator such that an additional quantity of gas is released thereby into the airbag(s) to thereby inflate the same at a second inflation rate greater than the first inflation rate. Thus, the airbag is inflated either at the first inflation rate, i.e., if the conditions do not warrant a more powerful inflation, or the second, higher inflation rate, i.e., if the conditions warrant an inflation of the airbags as rapidly as possible. The inflator may comprise a first and second inflator each of which produces gas and directs the gas into the airbag(s) and which are independent of one another such that the first inflator may be triggered by the initial determination of a crash requiring the airbag deployment without triggering of the second inflator and the second inflator may be triggered by the subsequent determination of a crash requiring airbag deployment without triggering of the first inflator.

Furthermore, the anticipatory sensor system described above may be used in conjunction with an airbag passive restraint system for protecting an occupant sitting in the seat adjacent the side door. Such a restraint system may comprise one or more airbag(s) arranged to be inflated between the occupant and the side door, sensor means for detecting that a crash requiring deployment of the airbag(s) is required, inflator means for releasing a gas into the airbag(s) to inflate the same and which are coupled to the sensor means and triggered thereby to release gas into the airbag(s) in response to the detection by the sensor means of a crash requiring deployment of the airbag(s), a seatbelt coupled to the seat for restraining the occupant on the seat and occupant displacement permitting means arranged in connection with the seat for permitting the occupant to be displaced away from the side door upon inflation of the airbag(s) and thereby increase the space between the occupant and the side door.

The occupant displacement permitting means may take a number of different forms all of which serve to enable the occupant to be displaced away from the side door, and if applied in conjunction with an airbag inflating between the side door and the occupant, the inflating airbag may provide a force which serves to actually displace the occupant away from the side door. One embodiment of the occupant displacement permitting means comprises slack introduction means arranged in connection with the seatbelt for introducing a controlled amount of slack into the seatbelt. Alternatively, the occupant displacement permitting means comprise means for changing an anchorage point of the seatbelt from a first anchorage point to a second anchorage point upon inflation of the airbag, both of which may be arranged on a side of the seat away from the side door. The second anchorage point is permanently fixed to the vehicle whereas the first anchorage point is defined by a strip permanently fixed to the vehicle, a first member is connected thereto, and a second member has a first position connected to the first member in which the seatbelt is retained at the first anchorage point and a second position apart from the first member in which the seatbelt is not retained at the first anchorage point. Separation means, such an explosive bolt assembly, are coupled to the sensor and move the second member from the first position to the second position so that the seatbelt is no longer retained at the first anchorage point and the displacement of the occupant is not hindered by the seatbelt.

In another embodiment, the system includes mounting means for mounting the airbag adjacent the occupant and the sensor is an anticipatory sensor structured and arranged to detect that a crash requiring deployment of the airbag is required based on data obtained prior to the crash such that the inflator means are triggered to release gas into the airbag prior to the start of the crash. In this case, the occupant displacement permitting means are optionally operatively associated with the anticipatory sensor and the seat to increase the space between the occupant and the side door upon inflation of the airbag. The occupant displacement permitting means may comprise means for laterally displacing the seat away from the side door such as one or more rail mechanisms, each including a first member having a guide channel arranged in connection with the seat or the vehicle and a second member positioned for movement in the guide channel arranged in the other of the seat and the vehicle. Alternatively, the occupant displacement permitting means comprise means for rotating the seat about the vehicle roll axis, possibly also by rail mechanisms, means for rotating the seat about the vehicle yaw axis or means for lifting the seat vertically. The seat lifting means may comprise a first plate attached to the seat, a second plate attached to the vehicle and hingedly attached to the first plate, and a clamp for releasably retaining the first plate in connection with the second plate.

Any of the airbag passive restraint systems described herein may be used in conjunction with the variable inflation rate inflator system described above, and may be used in conjunction with one another to optimize protection for the occupant.

In conjunction with the airbag passive restraint system for protecting an occupant sitting in the seat adjacent the side door described above, the present invention also envisions a method for protecting such an occupant. Such a method would include the steps of detecting that a crash requiring deployment of one or more airbags is required, if so, releasing a gas into the airbag(s) to inflate the same and then in before, during or after the gas is released into the airbag, causing the occupant to be displaced away from the side door upon inflation of the airbag(s) to thereby increase the space between the occupant and the side door. The manner in which the occupant is caused to be displaced away from the side door may take any of the forms described herein.

Other methods for protecting an adjacent occupant in a side impact within the scope of the invention includes the steps of mounting an airbag module comprising a housing and an inflatable airbag arranged within the housing in combination with a seat back, detecting that a side impact requiring deployment of the airbag is required based on data obtained prior to the crash, e.g., by an anticipatory sensor, and then inflating the airbag in the event a side impact requiring deployment of the airbag is detected prior to the start of the impact.

Another possible method entails the use of an externally deployable airbag system for protecting the occupant in a side impact with an impacting object. This method would include the steps of determining that a side impact requiring deployment of an airbag outside of the vehicle between the side of the vehicle and the impacting object is required based on data obtained prior to the crash, and then inflating the airbag in the event a side impact requiring deployment of the airbag is detected.

Although several preferred embodiments are illustrated and described above, there are possible combinations using other geometries, sensors, materials and different dimen-

sions for the components that perform the same functions. This invention is not limited to the above embodiments and should be determined by the following claims.

What is claimed is:

1. In a motor vehicle, a combined airbag inflation and occupant displacement enabling system comprising:

a seat movably attached to a floor pan of the vehicle for supporting an occupant;

at least one airbag arranged to be inflated from a first storage position to a second deployed position in which it is situated between the occupant and a vehicle structure and provides a cushion against which the occupant impacts during a crash to thereby protect the occupant during the crash from impacting the vehicle structure;

an inflator arranged to inflate said at least one airbag into the second position in which it provides the cushion against which the occupant impacts during the crash, and

an anticipatory sensor coupled to said inflator and structured and arranged to determine that a crash requiring deployment of said at least one airbag to prevent the occupant from contacting the vehicle structure will occur based on data obtained prior to the crash,

said inflator being triggered by said anticipatory sensor to inflate said at least one airbag prior to the start of the crash,

said seat being arranged to move automatically after the determination of the impending crash by said anticipatory sensor whereby movement of said seat causes displacement of the occupant and such that both the inflation of said at least one airbag by said inflator and the automatic movement of said seat are enabled by anticipatory sensing of the crash by said anticipatory sensor.

2. The vehicle of claim 1, further comprising seat displacement permitting means arranged in connection with said seat for permitting the seat to be displaced after determination of the impending crash by said anticipatory sensor.

3. The vehicle of claim 1, wherein said at least one airbag is arranged to inflate toward said seat such that said seat is moved upon inflation of said at least one airbag.

4. The vehicle of claim 1, further comprising:

a seatbelt coupled to the seat for restraining the occupant on said seat said seatbelt having a belted position in which said seatbelt restrains the occupant and an unbelted position in which the occupant is unrestrained; and

slack introduction means arranged in connection with said seatbelt and coupled to said sensor for introducing a controlled amount of slack into said seatbelt prior to or upon inflation of said at least one airbag.

5. The vehicle of claim 1, further comprising a seatbelt coupled to the seat for restraining the occupant on said seat, said seatbelt having a belted position in which said seatbelt restrains the occupant and an unbelted position in which the occupant is unrestrained, said seatbelt having a plurality of anchorage points with the anchorage point of said seatbelt being adjustable prior to or upon inflation of said at least one airbag.

6. The vehicle of claim 1, wherein said at least one airbag is arranged to be inflated between the occupant and a side door of the vehicle, said seat being arranged to move away from said side door upon inflation of said at least one airbag.

7. The vehicle of claim 1, further comprising at least one rail mechanism for movably supporting said seat such that said seat is movable upon inflation of said at least one airbag, each of said at least one rail mechanism including a first

member having a guide channel arranged in connection with said seat or the vehicle and a second member positioned for movement in said guide channel arranged in the other of said seat and the vehicle.

8. The vehicle of claim 7, wherein each of said at least one rail mechanism is oriented in a direction of deployment of said at least one airbag to thereby enable said seat to be moved away from said at least one airbag upon inflation of said at least one airbag.

9. The vehicle of claim 7, wherein said guide channel is curved and said second member is positioned for curving or rotational movement in said curved guide channel such that said seat is rotatable.

10. A method for protecting an occupant sitting in a seat during a crash of a vehicle, comprising the steps of:

movably attaching the seat to a floor pan of the vehicle; arranging at least one airbag to inflate from a first storage position to a second deployed position in which it is situated between the occupant and a vehicle structure and provides cushion against which the occupant impacts during a crash to thereby protect the occupant during the crash from impacting the vehicle structure;

determining that a crash requiring deployment of the at least one airbag to prevent the occupant from contacting the vehicle structure will occur prior to the crash based on anticipatory sensing;

inflating the at least one airbag into the second position in which it provides the cushion against which the occupant impacts during the crash based on the determination of the impending crash; and

constructing the seat to enable automatic movement of the seat after determination of the impending crash and prior to the crash such that both the inflation of the at least one airbag and the automatic movement of the seat are enabled by anticipatory sensing of the crash.

11. The method of claim 10, further comprising the steps of:

coupling a seatbelt to the seat; and

introducing a controlled amount of slack into the seatbelt prior to or upon inflation of the at least one airbag.

12. The method of claim 11, wherein the step of introducing a controlled amount of slack into the seatbelt comprises the steps of:

providing an electrically reactive device to introduce slack into the seatbelt; and

directing a signal to the reactive device in response to the determination of the impending crash.

13. The method of claim 10, further comprising the steps of:

coupling a seatbelt to the seat, the seatbelt having a plurality of anchorage points; and

adjusting the anchorage point of the seatbelt prior to or upon inflation of the at least one airbag.

14. The method of claim 13, wherein the step of adjusting the anchorage point of the seatbelt comprises the steps of:

providing an electrically reactive device to change the anchorage point of the seatbelt; and

directing a signal to the reactive device in response to the determination of the impending crash.

15. The method of claim 10, further comprising the step of positioning the at least one airbag to inflate between the seat and a side door of the vehicle such that the seat is moved away from the side door upon inflation of the at least one airbag.

16. The method of claim 10, wherein the step of constructing the seat to move after determination of the impending-

29

ing crash by and prior to the crash comprises the step of mounting the seat on at least one rail mechanism, each of the at least one rail mechanism including a first member having a guide channel arranged in connection with the seat or the vehicle and a second member positioned for movement in the guide channel arranged in the other of the seat and the vehicle.

17. The method of claim 16, further comprising the step of orienting each of the at least one rail mechanism in a direction of deployment of the at least one airbag to thereby enable the seat to be moved away from the at least one airbag upon inflation of the at least one airbag.

18. The method of claim 16, wherein the guide channel is curved and the second member is positioned for curving or rotational movement in the curved guide channel such that the seat is rotatable.

19. The method of claim 10, wherein the step of constructing the seat to move after determination of the impending crash by and prior to the crash comprises the step of constructing the seat to move upon exertion of a force caused by inflation of the at least one airbag.

20. In a motor vehicle, a combined airbag inflation and occupant displacement enabling system comprising:

a seat movably attached to a floor pan of the vehicle for supporting an occupant;

at least one airbag arranged to be inflated to protect the occupant during a crash;

an inflator arranged to inflate said at least one airbag;

an anticipatory sensor coupled to said inflator and structured and arranged to determine that a crash will occur based on data obtained prior to the crash, said inflator being triggered by said anticipatory sensor to inflate said at least one airbag; and

occupant displacement means coupled to said anticipatory sensor for displacing or enabling displacement of the occupant prior to inflation of said at least one airbag based on the determination of the impending crash by said anticipatory sensor such that both the inflation of said at least one airbag by said inflator and the displacement of the occupant by said occupant displacement means are enabled by anticipatory sensing of the crash by said anticipatory sensor.

21. The vehicle of claim 20, wherein said occupant displacement means comprise a pre-positioning airbag arranged to deploy prior to the crash and prior to deployment of said at least one airbag to move the occupant or a part of the occupant.

22. The vehicle of claim 20, further comprising:

a seatbelt coupled to the seat for restraining the occupant on said seat, said seatbelt having a belted position in which said seatbelt restrains the occupant and an unbelted position in which the occupant is unrestrained; and

slack introduction means arranged in connection with said seatbelt and coupled to said anticipatory sensor for introducing a controlled amount of slack into said seatbelt prior to inflation of said at least one airbag to thereby enable displacement of the occupant.

23. The vehicle of claim 22, wherein said slack introduction means comprise a spool on which an end of said seatbelt is wound, a sheave attached to said spool, a cable wound around said sheave, an actuator including a cylinder, a piston connected to said cable and movable within said cylinder and means defining a space between a bottom of said cylinder and said piston, and pressure generating means for generating a pressure in said space to force said piston in direction to cause said sheave to rotate and thus said spool to rotate and unwind said seatbelt from said spool.

30

24. The vehicle of claim 23, wherein said pressure generating means comprise a housing containing propellant, a squib arranged in connection with said housing and being activated by said anticipatory sensor to ignite said propellant and thereby produce pressurized gas, and a chamber in flow communication with said propellant to receive the pressurized gas, said chamber being in flow communication with said space in said actuator.

25. In a motor vehicle, a combined airbag inflation and occupant displacement enabling system comprising:

a seat movably attached to a floor pan of the vehicle for supporting an occupant;

at least one airbag arranged to be inflated from a first storage position to a second deployed position in which it is situated between the occupant and a vehicle structure and provides a cushion against which the occupant impacts during a crash to thereby protect the occupant during the crash from impacting the vehicle structure;

at least one sensor each arranged to determine that a crash requiring deployment of said at least one airbag to prevent the occupant from contacting the vehicle structure will occur or has occurred; and

an inflator arranged to inflate said at least one airbag into the second position in which it provides the cushion against which the occupant impacts during the crash, said inflator being coupled to said at least one sensor and being triggered to inflate said at least one airbag on response to the crash determination by said at least one sensor;

said seat being arranged to automatically move upon inflation of said at least one airbag whereby movement of said seat causes displacement of the occupant.

26. The vehicle of claim 25, further comprising seat displacement permitting means arranged in connection with said seat for permitting the seat to be displaced upon inflation of said at least one airbag.

27. The vehicle of claim 25, further comprising:

a seatbelt coupled to the seat for restraining the occupant on said seat, said seatbelt having a belted position in which said seatbelt restrains the occupant and an unbelted position in which the occupant is unrestrained; and

slack introduction means arranged in connection with said seatbelt and coupled to said at least one sensor for introducing a controlled amount of slack into said seatbelt prior to or upon inflation of said at least one airbag.

28. The vehicle of claim 27, wherein said slack introduction means comprise a spool on which an end of said seatbelt is wound, a sheave attached to said spool, a cable wound around said sheave, an actuator including a cylinder, a piston connected to said cable and movable within said cylinder and means defining a space between a bottom of said cylinder and said piston, and pressure generating means for generating a pressure in said space to force said piston in direction to cause said sheave to rotate and thus said spool to rotate and unwind said seatbelt from said spool, said pressure generating means comprising a housing containing propellant, a squib arranged in connection with said housing and being activated by said sensor to ignite said propellant and thereby produce pressurized gas, and a chamber in flow communication with said propellant to receive the pressurized gas, said chamber being in flow communication with said space in said actuator.

29. The vehicle of claim 25, further comprising a seatbelt coupled to the seat for restraining the occupant on said seat, said seatbelt having a belted position in which said seatbelt

31

restrains the occupant and an unbelted position in which the occupant is unrestrained, said seatbelt having a plurality of anchorage points with the anchorage point of said seatbelt being adjustable prior to or upon inflation of said at least one airbag.

30. The vehicle of claim **29**, wherein said plurality of anchorage points includes a first anchorage point defined by a strip permanently fixed to the vehicle and a second anchorage point permanently fixed to the vehicle, further comprising:

a first member connected to said strip;

a second member having a first position connected to said first member in which said seatbelt is retained at said first anchorage point and a second position apart from said first member in which said seatbelt is not retained at said first anchorage point; and

separation means coupled to said at least one sensor for moving said second member from said first position to said second position so that said seatbelt is no longer retained at said first anchorage point and the movement of the seat is not hindered by said seatbelt.

31. The vehicle of claim **25**, wherein said at least one airbag is arranged to be inflated between a side door of the vehicle and a side of said seat adjacent said side door, said seat being arranged to be moved away from said side door upon inflation of said at least one airbag.

32. The vehicle of claim **25**, wherein said at least one sensor comprises an anticipatory sensor structured and arranged to detect that a crash will occur based on data obtained prior to the crash such that said inflator is triggered to release fluid into said at least one airbag prior to the start of the crash.

33. The vehicle of claim **25**, further comprising at least one rail mechanism for movably supporting said seat such that said seat is movable upon inflation of said at least one airbag, each of said at least one rail mechanism including a first member having a guide channel arranged in connection with said seat or the vehicle and a second member positioned for movement in said guide channel arranged in the other of said seat and the vehicle.

34. The vehicle of claim **25**, further comprising a first plate attached to said seat, a second plate attached to the vehicle and hingedly attached to said first plate, and a clamp for releasably retaining said first plate in connection with said second plate whereby release of said first plate enables tilting of said seat.

35. A method for protecting an occupant sitting in a seat during a crash of a vehicle, comprising the steps of:

movably attaching the seat to a floor pan of the vehicle;

arranging at least one airbag to inflate from a first storage position to a second deployed position in which it is situated between the occupant and a vehicle structure and provides cushion against which the occupant impacts during a crash to thereby protect the occupant during the crash from impacting the vehicle structure;

determining that a crash requiring deployment of the at least one airbag to prevent the occupant from contacting the vehicle structure will occur or has occurred;

inflating the at least one airbag in response to the crash determination into the second position in which it provides the cushion against which the occupant impacts during the crash; and

constructing the seat to enable automatic movement of the seat upon inflation of the at least one airbag.

36. The method of claim **35**, further comprising the steps of:

32

coupling a seatbelt to the seat; and

introducing a controlled amount of slack into the seatbelt prior to or upon inflation of the at least one airbag by providing an electrically reactive device to introduce slack into the seatbelt and directing a signal to the reactive device in response to the crash determination.

37. The method of claim **35**, further comprising the steps of:

coupling a seatbelt to the seat, the seatbelt having a plurality of anchorage points; and

adjusting the anchorage point of the seatbelt prior to or upon inflation of the at least one airbag by providing an electrically reactive device to change the anchorage point of the seatbelt and directing a signal to the reactive device in response to the crash determination.

38. The method of claim **35**, further comprising the step of positioning the at least one airbag to inflate between a side door of the vehicle and a side of the seat adjacent the side door of the vehicle such that the seat is moved away from the side door upon inflation of the at least one airbag.

39. The method of claim **35**, wherein the step of constructing the seat to move upon inflation of the at least one airbag comprises the step of mounting the seat on at least one rail mechanism, each of the at least one rail mechanism including a first member having a guide channel arranged in connection with the seat or the vehicle and a second member positioned for movement in the guide channel arranged in the other of the seat and the vehicle.

40. The method of claim **39**, further comprising the step of orienting each of the at least one rail mechanism in a direction of deployment of the at least one airbag to thereby enable the seat to be moved away from the at least one airbag upon inflation of the at least one airbag.

41. The method of claim **35**, wherein the step of constructing the seat to move upon inflation of the at least one airbag comprises the step of arranging the seat to tilt in a vertical plane by attaching a first plate to the seat, attaching a second plate to the vehicle, pivotally connecting the first and second plate together.

42. In a motor vehicle, a combined airbag inflation and occupant displacement enabling system comprising:

a seat movably attached to a floor pan of the vehicle for supporting an occupant;

at least one airbag arranged to be inflated to protect the occupant during a crash;

an inflator arranged to inflate said at least one airbag;

an anticipatory sensor coupled to said inflator and structured and arranged to determine that a crash requiring deployment of said at least one airbag will occur based on data obtained prior to the crash, said inflator being triggered by said anticipatory sensor to inflate said at least one airbag prior to the start of the crash, said seat being arranged to move automatically after the determination of the impending crash by said anticipatory sensor whereby movement of said seat causes displacement of the occupant; and

at least one rail mechanism for movably supporting said seat such that said seat is movable upon inflation of said at least one airbag, each of said at least one rail mechanism including a first member having a guide channel arranged in connection with said seat or the vehicle and a second member positioned for movement in said guide channel arranged in the other of said seat and the vehicle,

each of said at least one rail mechanism being oriented in a direction of deployment of said at least one airbag to thereby enable said seat to be moved away from said at least one airbag upon inflation of said at least one airbag.

43. A method for protecting an occupant sitting in a seat during a crash of a vehicle, comprising the steps of:
 movably attaching the seat to a floor pan of the vehicle;
 determining that a crash requiring deployment of at least one airbag will occur prior to the crash;
 inflating the at least one airbag based on the determination of the impending crash; and
 constructing the seat to enable automatic movement of the seat after determination of the impending crash and prior to the crash,
 the step of constructing the seat to enable movement thereof after determination of the impending crash by and prior to the crash comprising the steps of:
 mounting the seat on at least one rail mechanism, each of the at least one rail mechanism including a first member having a guide channel arranged in connection with the seat or the vehicle and a second member positioned for movement in the guide channel arranged in the other of the seat and the vehicle; and
 orienting each of the at least one rail mechanism in a direction of deployment of the at least one airbag to thereby enable the seat to be moved away from the at least one airbag upon inflation of the at least one airbag.

44. In a motor vehicle, a combined airbag inflation and occupant displacement enabling system comprising:
 a seat movably attached to a floor pan of the vehicle for supporting an occupant;
 at least one airbag arranged to be inflated to protect the occupant during a crash;
 an inflator arranged to inflate said at least one airbag;
 an anticipatory sensor coupled to said inflator and structured and arranged to determine that a crash will occur based on data obtained prior to the crash, said inflator being triggered by said anticipatory sensor to inflate said at least one airbag; and
 occupant displacement means coupled to said anticipatory sensor for displacing or enabling displacement of the occupant prior to inflation of said at least one airbag based on the determination of the impending crash by said anticipatory sensor,
 said occupant displacement means comprising a pre-positioning airbag arranged to deploy prior to the crash and prior to deployment of said at least one airbag to move the occupant or a part of the occupant.

45. In a motor vehicle, a combined airbag inflation and occupant displacement enabling system comprising:
 a seat movably attached to a floor pan of the vehicle for supporting an occupant;
 at least one airbag arranged to be inflated to protect the occupant during a crash;
 an inflator arranged to inflate said at least one airbag;
 an anticipatory sensor coupled to said inflator and structured and arranged to determine that a crash will occur based on data obtained prior to the crash, said inflator being triggered by said anticipatory sensor to inflate said at least one airbag;
 occupant displacement means coupled to said anticipatory sensor for displacing or enabling displacement of the occupant prior to inflation of said at least one airbag based on the determination of the impending crash by said anticipatory sensor;

a seatbelt coupled to the seat for restraining the occupant on said seat said seatbelt having a belted position in which said seatbelt restrains the occupant and an unbelted position in which the occupant is unrestrained; and
 slack introduction means arranged in connection with said seatbelt and coupled to said anticipatory sensor for introducing a controlled amount of slack into said seatbelt prior to inflation of said at least one airbag to thereby enable displacement of the occupant.

46. In a motor vehicle, a combined airbag inflation and occupant displacement enabling system comprising:
 a seat movably attached to a floor pan of the vehicle for supporting an occupant;
 at least one airbag arranged to be inflated to protect the occupant during a crash;
 at least one sensor each arranged to determine that a crash requiring deployment of said at least one airbag will occur or has occurred;
 an inflator arranged to inflate said at least one airbag, said inflator being coupled to said at least one sensor and being triggered to inflate said at least one airbag in response to the crash determination by said at least one sensor, said seat being arranged to automatically move upon inflation of said at least one airbag whereby movement of said seat causes displacement of the occupant,
 a seatbelt coupled to the seat for restraining the occupant on said seat, said seatbelt having a belted position in which said seatbelt restrains the occupant and an unbelted position in which the occupant is unrestrained; and
 slack introduction means arranged in connection with said seatbelt and coupled to said at least one sensor for introducing a controlled amount of slack into said seatbelt prior to or upon inflation of said at least one airbag.

47. In a motor vehicle, a combined airbag inflation and occupant displacement enabling system comprising:
 a seat movably attached to a floor pan of the vehicle for supporting an occupant;
 at least one airbag arranged to be inflated to protect the occupant during a crash;
 at least one sensor each arranged to determine that a crash requiring deployment of said at least one airbag will occur or has occurred; and
 an inflator arranged to inflate said at least one airbag, said inflator being coupled to said at least one sensor and being triggered to inflate said at least one airbag in response to the crash determination by said at least one sensor, said seat being arranged to automatically move upon inflation of said at least one airbag whereby movement of said seat causes displacement of the occupant,
 said at least one sensor comprising an anticipatory sensor structured and arranged to detect that a crash will occur based on data obtained prior to the crash such that said inflator is triggered to release fluid into said at least one airbag prior to the start of the crash.