



US006745059B2

(12) **United States Patent**
Buczek et al.

(10) **Patent No.: US 6,745,059 B2**
(45) **Date of Patent: Jun. 1, 2004**

(54) **SUPERCONDUCTOR CABLES AND MAGNETIC DEVICES**

(75) Inventors: **David M. Buczek**, Dover, MA (US);
John D. Scudiere, Bolton, MA (US);
Leslie G. Fritzemeier, Mendon, MA (US)

(73) Assignee: **American Superconductor Corporation**, Westborough, MA (US)

(*) Notice: Subject to any disclaimer, the term of this patent is extended or adjusted under 35 U.S.C. 154(b) by 67 days.

(21) Appl. No.: **09/995,442**

(22) Filed: **Nov. 28, 2001**

(65) **Prior Publication Data**

US 2003/0099870 A1 May 29, 2003

(51) **Int. Cl.**⁷ **H01B 12/00**; H01F 6/00;
H01L 39/00

(52) **U.S. Cl.** **505/230**; 505/235

(58) **Field of Search** 505/230, 231,
505/235, 238; 428/699, 701, 702

(56) **References Cited**

U.S. PATENT DOCUMENTS

- 4,028,488 A * 6/1977 McDougall 174/125.1
- 4,195,199 A * 3/1980 Hillmann et al. 174/125.1
- 4,994,435 A 2/1991 Shiga et al.
- 5,104,849 A 4/1992 Shiga et al.
- 5,202,305 A 4/1993 Watanabe et al.
- 5,231,074 A 7/1993 Cima et al.
- 5,232,908 A 8/1993 Shiga et al.
- 5,801,124 A 9/1998 Gamble et al. 505/230
- 6,022,832 A 2/2000 Fritzemeier et al.

- 6,027,564 A 2/2000 Fritzemeier et al.
- 6,190,752 B1 2/2001 Do et al.
- 6,444,917 B1 * 9/2002 Scudiere et al. 174/125.1
- 6,507,746 B2 * 1/2003 Kaneko 505/231

FOREIGN PATENT DOCUMENTS

- EP 0 312 015 A2 4/1989
- EP 0 423 354 A1 4/1991
- EP 0 623 937 A2 11/1994
- JP 01-276511 7/1989
- JP 01-276511 11/1989
- JP 04203861 2/1994
- WO WO 98/58415 12/1998
- WO WO 99/14770 3/1999
- WO WO 99/16941 4/1999
- WO WO 99/17307 4/1999
- WO WO 00/39812 7/2000
- WO WO 00/58044 10/2000
- WO WO 00/58530 10/2000
- WO WO 01/08169 2/2001
- WO WO 01/08170 2/2001
- WO WO 01/08232 2/2001
- WO WO 01/08233 2/2001
- WO WO 01/08233 A2 2/2001
- WO WO 01/08235 2/2001
- WO WO 01/08236 2/2001
- WO WO 01/26164 4/2001
- WO WO 01/26165 4/2001
- WO WO 02/15203 A1 4/2002
- WO WO 02/35615 5/2002

* cited by examiner

Primary Examiner—Tom Dunn

Assistant Examiner—Colleen P. Cooke

(74) *Attorney, Agent, or Firm*—Fish & Richardson P.C.

(57) **ABSTRACT**

Superconducting cables and magnetic devices are disclosed.

35 Claims, 5 Drawing Sheets

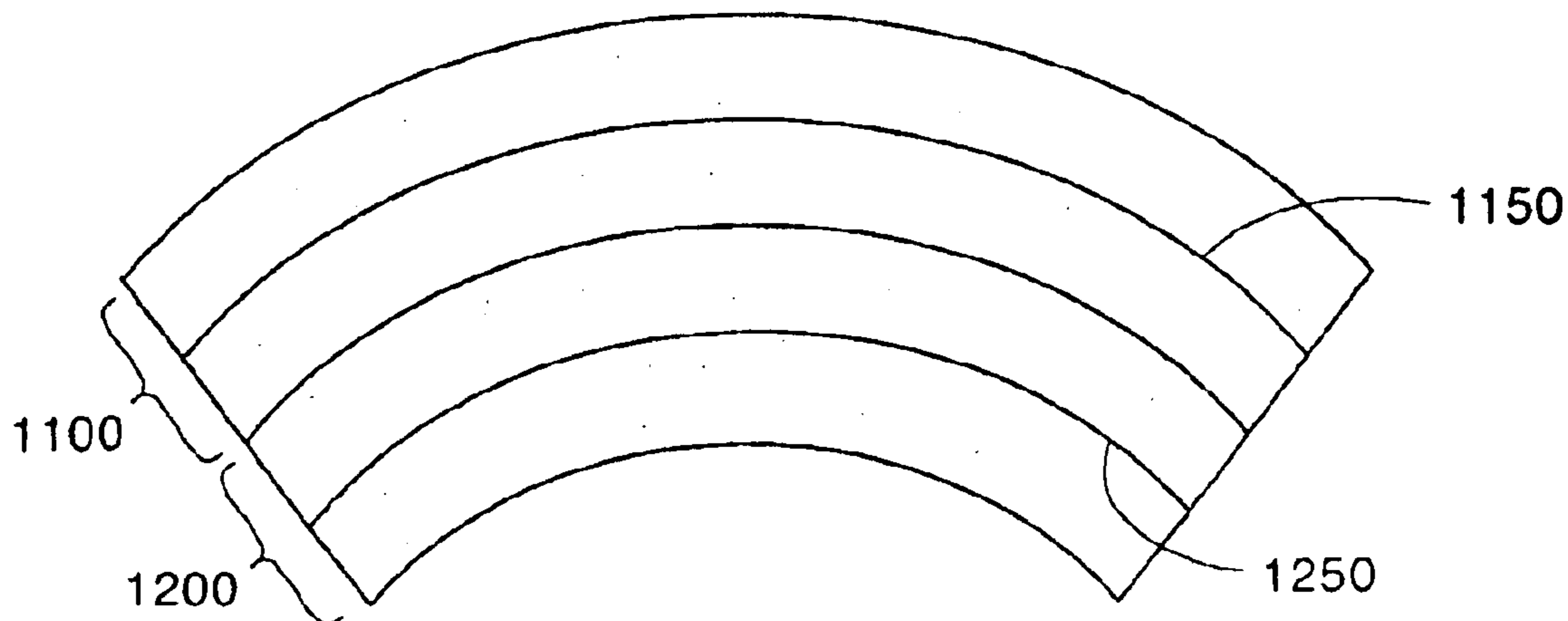

FIG. 1

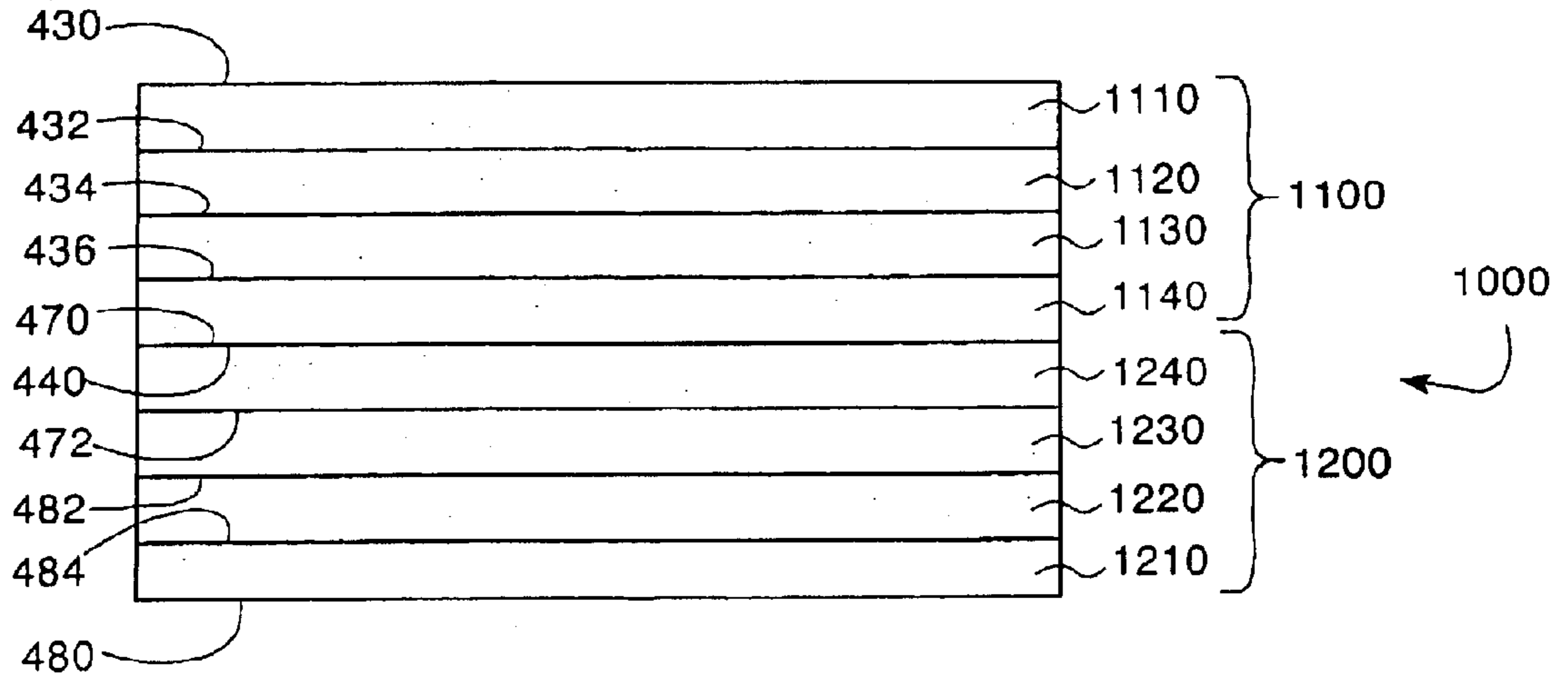

FIG. 2

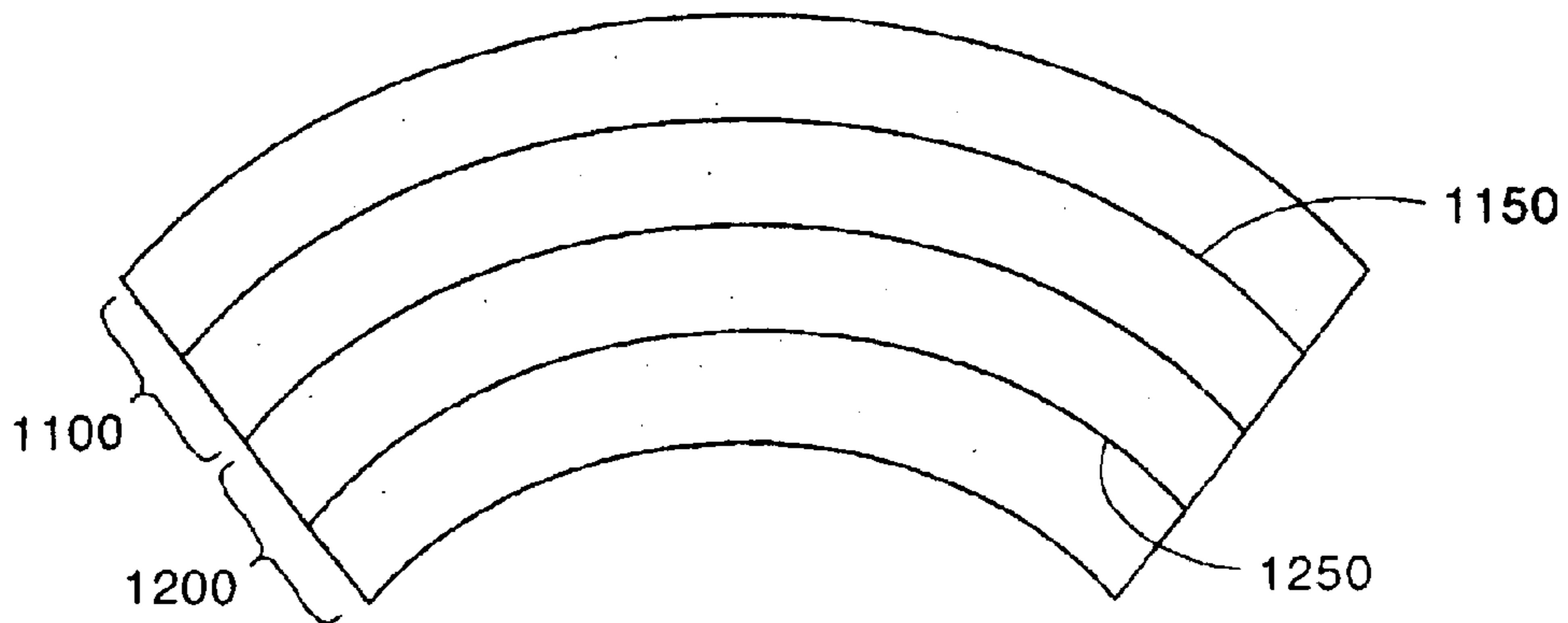

FIG. 3

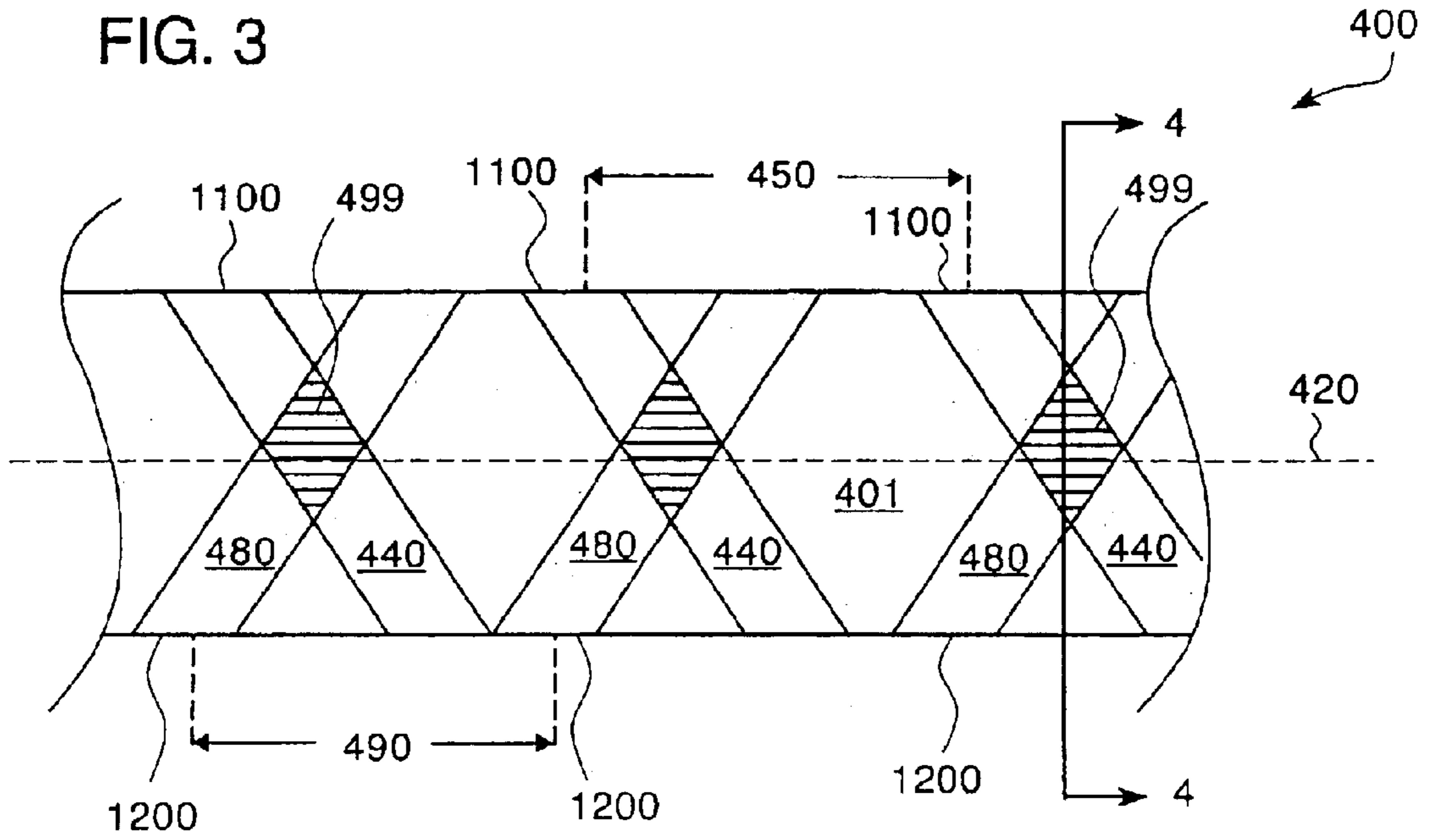

FIG. 4

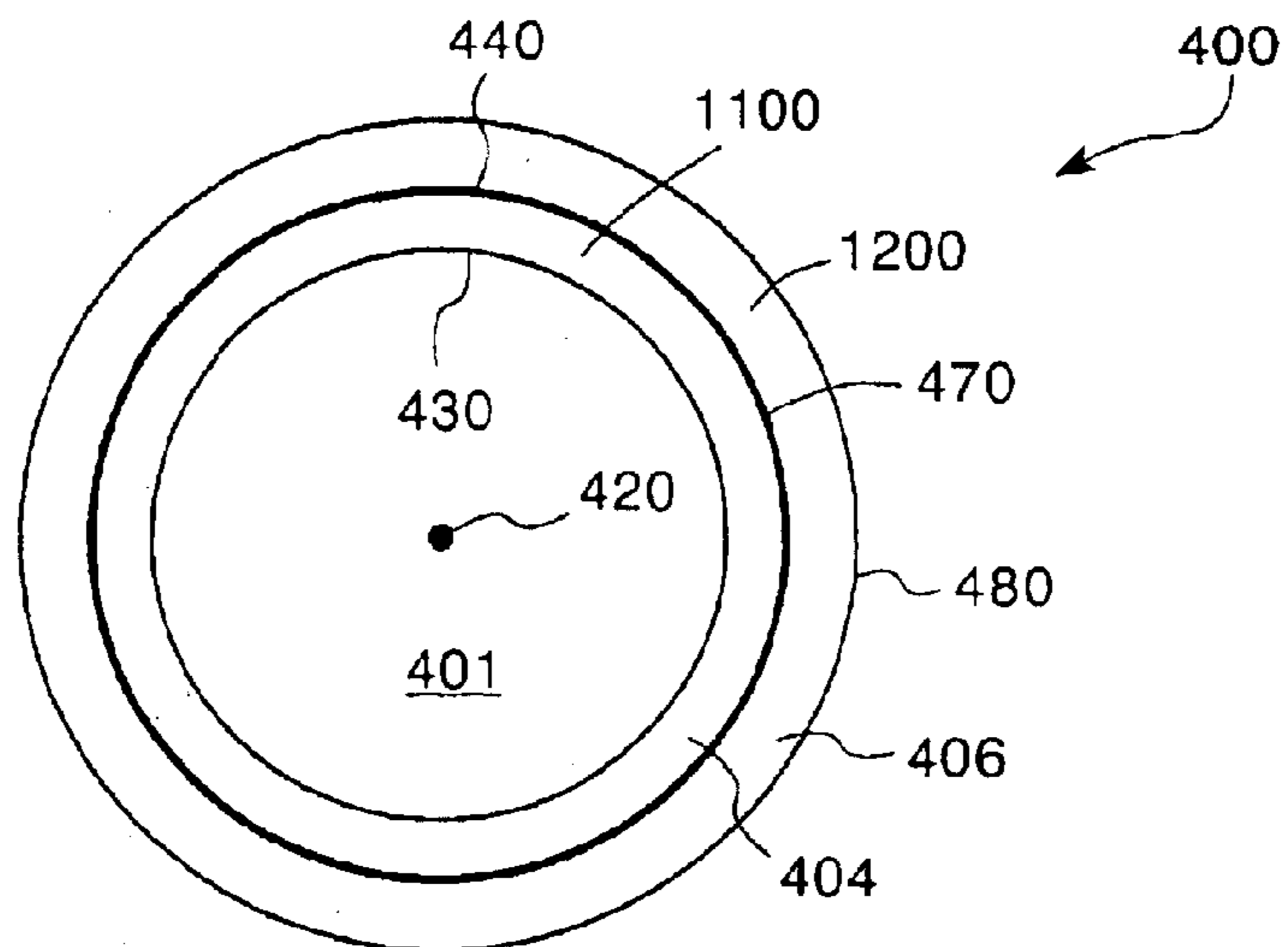

FIG. 5A

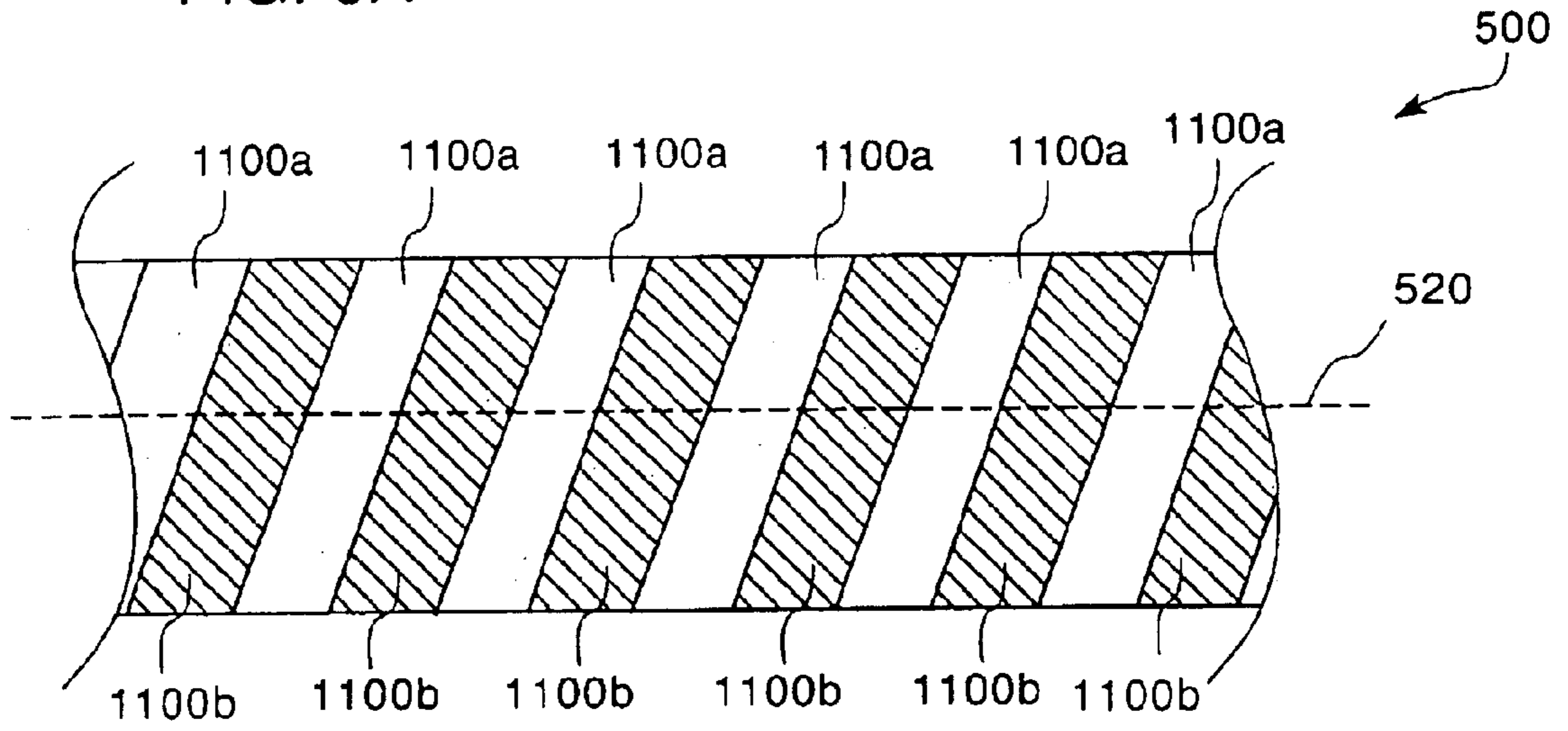

FIG. 6

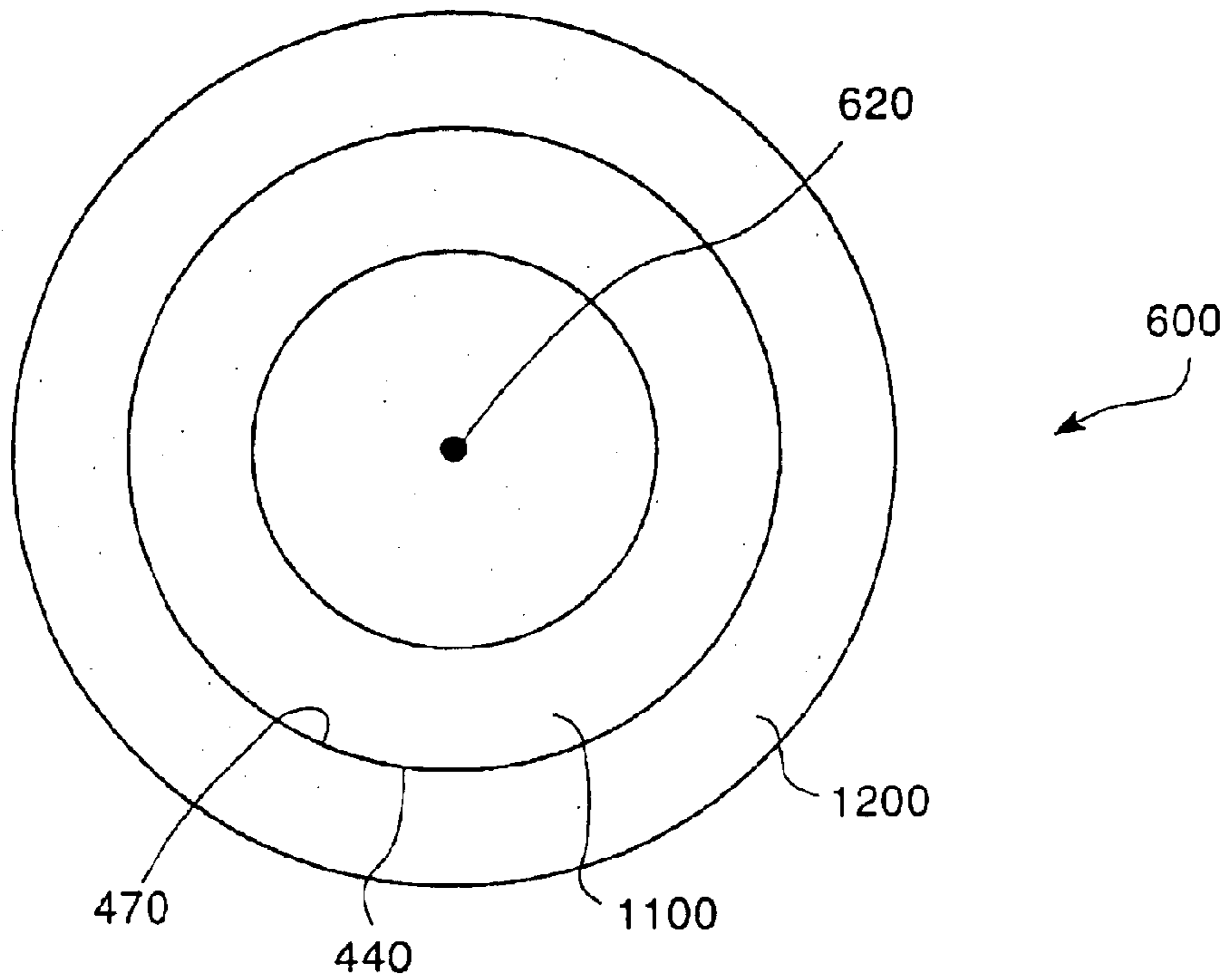

FIG. 5B

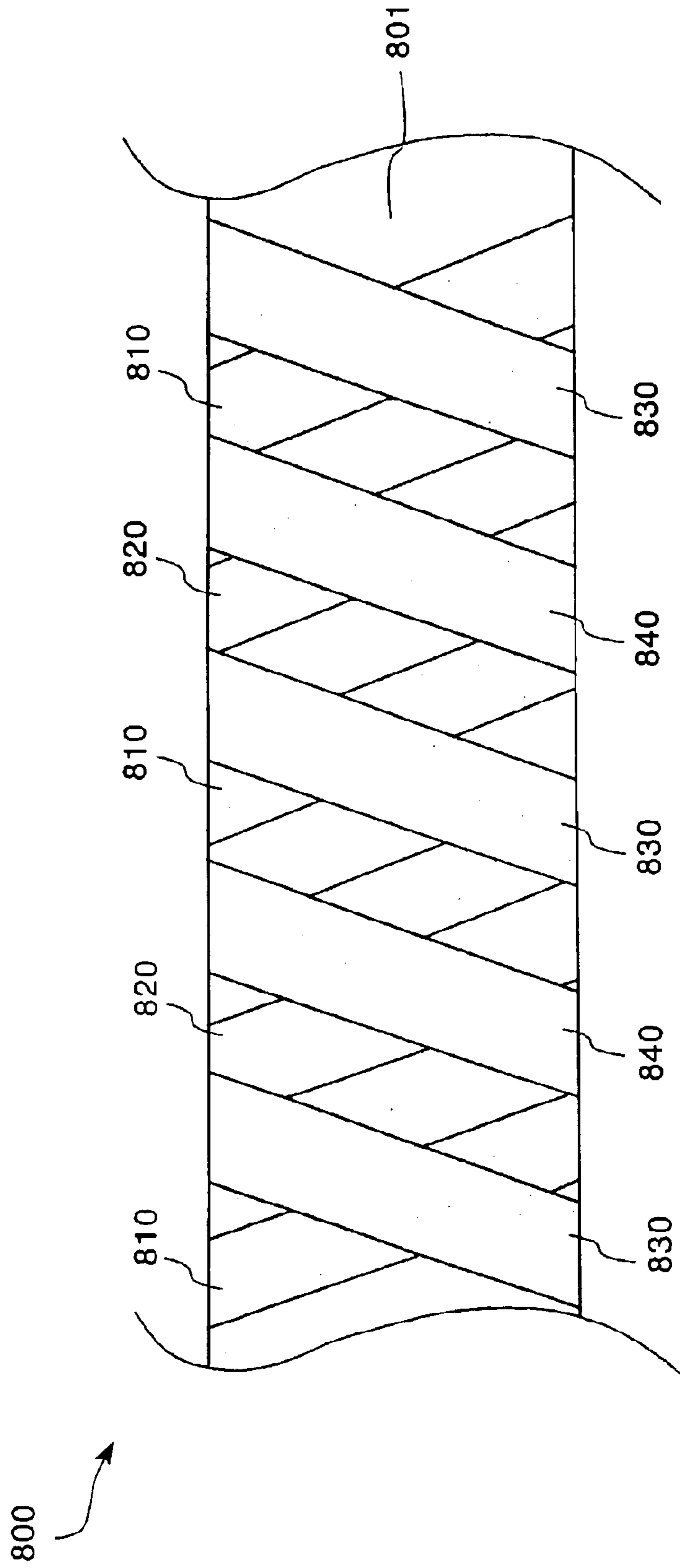

FIG. 7A

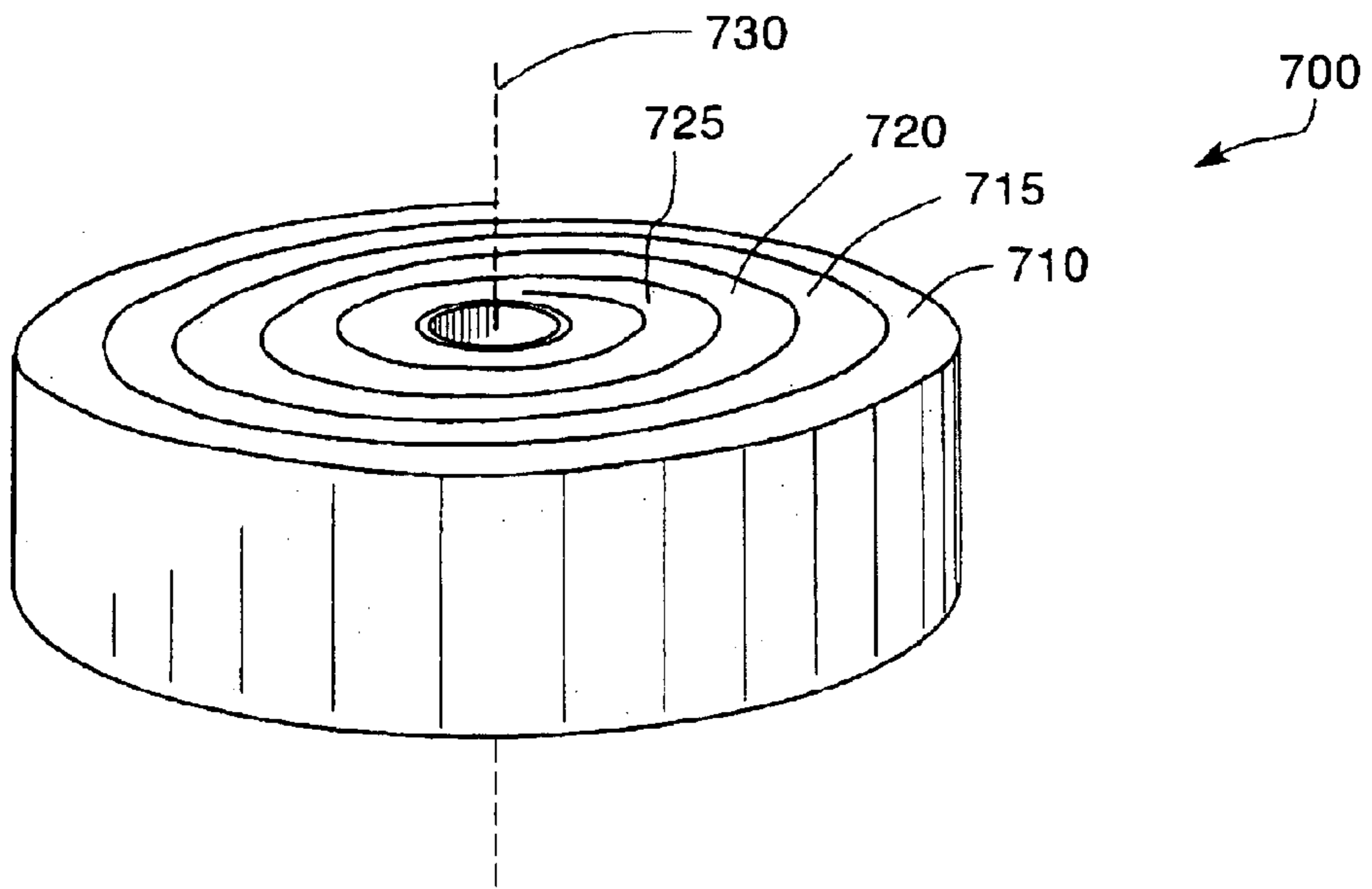
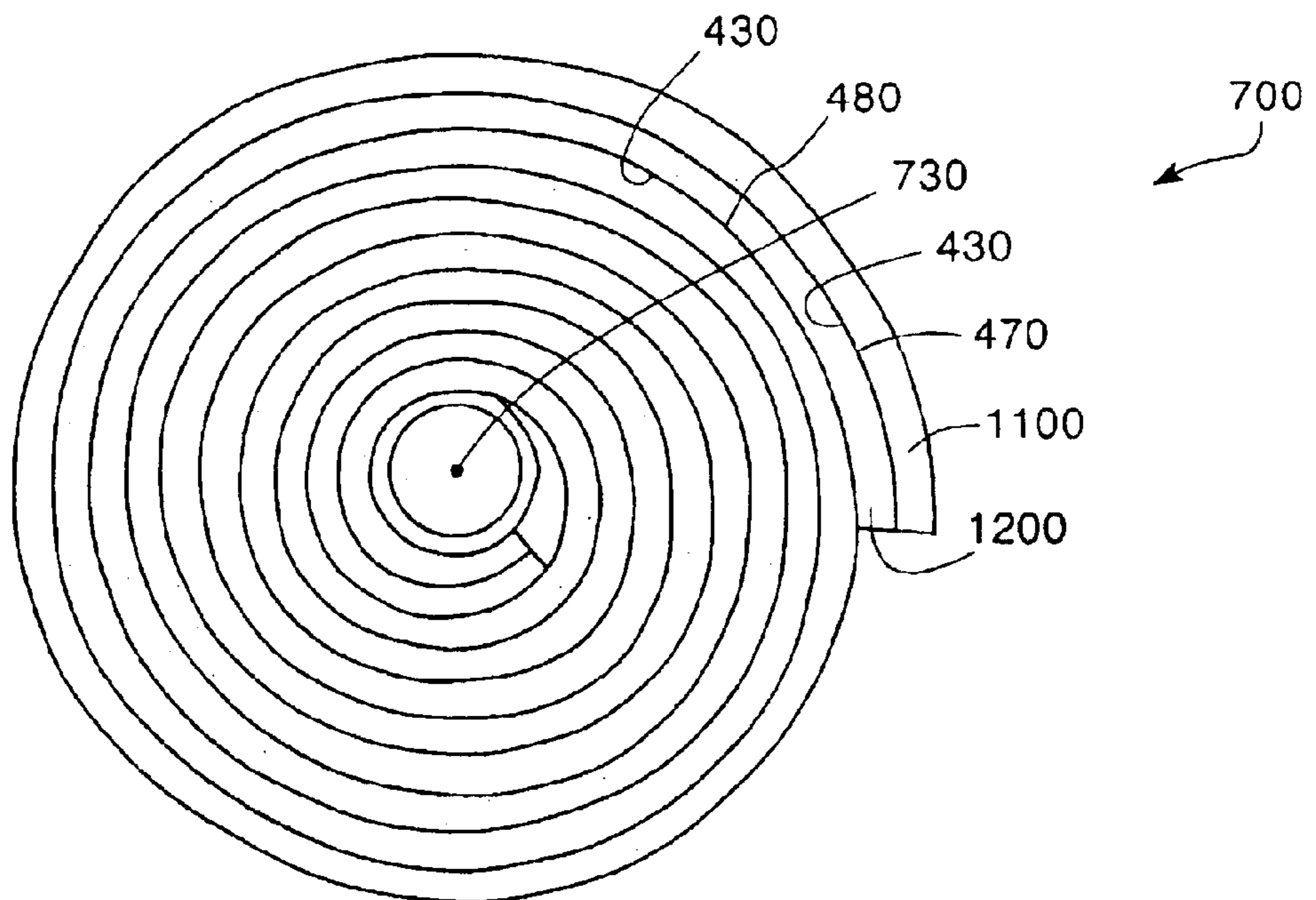

FIG. 7B



SUPERCONDUCTOR CABLES AND MAGNETIC DEVICES

INCORPORATION BY REFERENCE

The following documents are hereby incorporated by reference: U.S. Pat. No. 5,231,074, issued on Jul. 27, 1993, and entitled "Preparation of Highly Textured Oxide Superconducting Films from MOD Precursor Solutions," U.S. Pat. No. 6,022,832, issued Feb. 8, 2000, and entitled "Low Vacuum Process for Producing Superconductor Articles with Epitaxial Layers," U.S. Pat. No. 6,027,564, issued Feb. 22, 2000, and entitled "Low Vacuum Process for Producing Epitaxial Layers," U.S. Pat. No. 6,190,752, issued Feb. 20, 2001, and entitled "Thin Films Having Rock-Salt-Like Structure Deposited on Amorphous Surfaces," PCT Publication No. WO 00/58530, published on Oct. 5, 2000, and entitled "Alloy Materials," PCT Publication No. WO/58044, published on Oct. 5, 2000, and entitled "Alloy Materials," PCT Publication No. WO 99/17307, published on Apr. 8, 1999, and entitled "Substrates with Improved Oxidation Resistance," PCT Publication No. WO 99/16941, published on Apr. 8, 1999, and entitled "Substrates for Superconductors," PCT Publication No. WO 98/58415, published on Dec. 23, 1998, and entitled "Controlled Conversion of Metal Oxyfluorides into Superconducting Oxides," commonly owned U.S. patent application Ser. No. 09/616,810, filed on Jul. 14, 2000, and entitled "Superconductor Articles and Compositions and Methods for Making Same," commonly owned U.S. patent application Ser. No. 09/615,991, filed on Jul. 14, 2000, and entitled "Methods and Compositions for Making a Multi-layer Article," commonly owned U.S. patent application Ser. No. 09/618,811, filed on Jul. 14, 2000, and entitled "Methods of Making A Superconductor," commonly owned U.S. patent application Ser. No. 09/694,400, filed on Oct. 23, 2000 now abandoned, and entitled "Precursor Solutions and Methods of Using Same," commonly owned U.S. patent application Ser. No. 09/500,717, filed on Feb. 9, 2000 now U.S. Pat. No. 6,562,761, and entitled "Coated Conductor Thick Film Precursor," commonly owned U.S. patent application Ser. No. 09/616,566, filed on Jul. 14, 2000 now abandoned, and entitled "Control of Oxide Layer Reaction Rates," commonly owned U.S. patent application Ser. No. 09/617,518, filed on Jul. 14, 2000, and entitled "Enhanced High Temperature Coated Superconductors," commonly owned U.S. patent application Ser. No. 09/617,520, filed on Jul. 14, 2000, and entitled "Enhanced Purity Oxide Layer Formation," commonly owned U.S. patent application Ser. No. 09/615,669, filed on Jul. 14, 2000 now abandoned, and entitled "Oxide Layer Method," commonly owned U.S. patent application Ser. No. 09/615,999, filed on Jul. 14, 2000, and entitled "Multi-layer Articles and Methods of Making Same," commonly owned U.S. patent application Ser. No. 09/500,718 now abandoned, filed on Feb. 9, 2000, and entitled "Coated Conductors with Reduced AC Loss," commonly owned U.S. patent application Ser. No. 09/855,312, filed on May 14, 2001, and entitled "Precursor Solutions and Methods of Using Same," commonly owned U.S. patent application Ser. No. 09/918,167, filed on Jul. 30, 2001, and entitled "Ion Texturing Methods and Articles," commonly owned U.S. Provisional Patent Application Serial No. 60/305,478, filed Jul. 13, 2001, and entitled "Low Stress Superconductor," and commonly owned U.S. Provisional Patent Application Serial No. 60/308,957, filed on Jul. 31, 2001, and entitled "Superconductor Methods And Reactors."

TECHNICAL FIELD

The invention relates to superconductor cables and magnetic devices.

BACKGROUND

Multi-layer superconductor articles, such as tapes, having various architectures have been developed. Such articles often include a substrate and a superconductor layer. Typically, one or more buffer layers are disposed between the substrate and the superconductor layer.

SUMMARY

In general, the invention relates to superconductor cables and magnetic devices.

In one aspect, the invention features an article that includes a first layer formed of a first superconductor material and a second layer formed of a first electrically conductive material. The article also includes a third layer formed of a second superconductor material and a fourth layer formed of a second electrically conductive material. The second layer is mechanically coupled to the first layer (e.g., mechanically coupled at points other than their ends), and the fourth layer is mechanically coupled to the third layer (e.g., mechanically coupled at points other than their ends). The second and fourth layers are in electrical communication. The first and second layers have a neutral mechanical axis when bent that is different than the neutral mechanical axis of the third and fourth layers when bent.

The phrase "mechanically coupled," as used herein, refers to a force between (e.g., at the interface of) two layers that substantially reduces (e.g., eliminates) the ability of one layer to move independently of the other layer. One example of mechanically coupled layers is two layers that are chemically bonded together. Another example of mechanically coupled layer is two layers that are metallurgically bonded together. An additional example of mechanically coupled layers is two layers that are each adhered to an adhesive layer therebetween. It is to be noted that two layers (or other articles, such as tapes) generally are not mechanically coupled when the layers (or articles) are held in compression against each other by a force acting from outside (as opposed to at the interface of) the two layers. For example, if two tapes are wrapped within insulation that provides a compressive force that holds the tapes in proximity to each other, this force itself does not render the tapes mechanically coupled, although the tapes may otherwise be mechanically coupled (e.g., if the tapes are chemically or metallurgically bonded to each other).

The article can be configured so that the second and fourth layers can move independently of each other.

The first and second superconductor materials can be the same or different. For example, one or both of the superconductor materials can be a rare earth superconductor material, such as YBCO.

The first and second electrically conductive materials can be the same or different. For example, the first and second electrically conductive materials can be a metal (e.g., copper) or an alloy (e.g., a copper alloy).

The first and second layers can be in the form of a tape. The second and third layers can be in the form of a tape.

The article can further include first and second substrates. The first layer can be between the first substrate and the second layer, and the third layer can be between the second substrate and the fourth layer.

The article can further include first and second buffer layers. The first buffer layer can be between the first substrate and the first layer, and the second buffer layer can be between the second substrate and the third layer.

In some embodiments, the first substrate layer has a thickness that is about equal to a combined thickness of the first layer, the first buffer layer, and the second layer.

In certain embodiments, the fourth layer has a thickness that is about equal to a combined thickness of the third layer, the second buffer layer, and the second substrate layer.

The article can further include first and second cap layers. The first cap layer can be between the first and second layers, and the second cap layer can be between the third and fourth layers.

The article can further include an interfacial layer between the second and fourth layers. The interfacial layer is generally formed of an electrically conductive material and can be, for example, capable of reducing oxidation of the second and fourth layers, and/or reducing friction between the second and the fourth layer. In some embodiments, the interfacial layer is at least partially formed or graphite.

In another aspect, the invention features an article (e.g., a cable) that includes first and second helically wound superconductor tapes. The first tape includes a superconductor layer and an electrically conductive layer, and the second tape that includes a superconductor layer and an electrically conductive layer. The electrically conductive layers of the first and second tapes are in electrical communication (e.g., in electrical communication at more than one position, such as by contacting each other in more than one location). The first helically wound superconductor tape has a neutral mechanical axis, and the second helically wound superconductor tape has a different neutral mechanical axis.

The first and second helically wound tapes can be configured so that they can move independently of each other.

The article can further include a forming element around which the first and second tapes are helically wound.

In some embodiments, the superconductor layers of the first and/or second superconductor tapes are mechanically compressed.

The first and second helically wound superconductor tapes can have a common helical axis.

In some embodiments, the article further includes third and fourth helically wound superconductor tapes. The third helically wound superconductor tape includes a superconductor layer and an electrically conductive layer, and the fourth helically wound superconductor tape includes a superconductor layer and an electrically conductive layer. The electrically conductive layers of the third and fourth superconductor tapes have more than one point of electrical communication (e.g., by contacting each other in more than one location). The third and fourth helically wound superconductor tapes can have a common helical axis.

In certain embodiments, the electrically conductive layers of the first and second superconductor tapes at least partially overlap. In some embodiments, the electrically conductive layers of the first and second superconductor tapes substantially entirely overlap.

In a further aspect, the invention features an article that includes first and second pluralities of helically wound tapes. In the first plurality of helically wound superconductor tapes, each tape includes a layer of a superconductor material and a layer of an electrically conductive material, and each tape is wound in parallel in a first direction. In the second plurality of helically wound superconductor tapes, each tape includes a layer of a superconductor material and a layer of an electrically conductive material, and each tape is wound in parallel in a second direction opposite the first direction. The layer of the electrically conductive materials in each tape in the first plurality of tapes has more than one position of electrical communication with the layer of elec-

trically conductive material in each tape of the second plurality of tapes (e.g., by contacting each other in more than one location).

In some embodiments, the first and second pluralities of helically wound superconductor tapes have a common helical axis.

In certain embodiments, the electrically conductive layers of each tape in the first plurality of superconductor tapes at least partially overlap with the electrically conductive layers of each tape in the second plurality of superconductor tapes.

Each of the tapes in the article can have a different neutral mechanical axis when bent than the neutral mechanical axis of any of the other tapes when bent.

In an additional aspect, the invention features a superconducting magnetic coil that includes first and second coiled superconductor tapes. Each coiled superconductor tape is coiled about a respective coil axis. The first coiled superconductor tape includes a superconductor layer and an electrically conductive layer. The electrically conductive layer of the first coiled superconductor tape has a surface that forms an inner surface of the first coiled superconductor tape. The inner surface of the first coiled superconductor tape faces the coil axis of the first coiled superconductor tape. The second coiled superconductor includes a superconductor layer and an electrically conductive layer. The electrically conductive layer of the second coiled superconductor tape has a surface that forms an outer surface of the second coiled superconductor tape. The outer surface of the second coiled superconductor tape faces away from the coil axis of the second coiled superconductor tape. The first and second coiled superconductor tapes are configured so that inner surface of the first superconductor tape is adjacent the outer surface of the second superconductor tape.

The first and second superconductor tapes in the magnetic coil can have different neutral mechanical axes from each other.

In some embodiments, the first and second coiled superconductor tapes contact each other.

In certain embodiments, the first and second coiled superconductor tapes are wound together.

In some embodiments, the coil axis of the first superconductor tape is the same as the coil axis of the second superconductor tape.

In certain embodiments, the first and second superconductor tapes are coiled about each other.

In some embodiments, the superconductor layer and electrically conductive layer of the first superconductor tape are mechanically coupled (e.g., mechanically coupled at points other than their ends), and the superconductor layer and electrically conductive layer of the second superconductor tape are mechanically coupled (e.g., mechanically coupled at points other than their ends).

In certain embodiments, the superconductor layers of the first and/or second superconductor tapes are mechanically compressed.

The superconducting magnetic coil can further include an interfacial layer disposed between the adjacent first and second superconductor tapes.

The superconducting magnetic coil can further include third and fourth coiled superconductor tapes. Each of the third and fourth coiled superconductor tapes is coiled about a respective coil axis. The third coiled superconductor tape includes a superconductor layer and an electrically conductive layer. The electrically conductive layer of the third coiled superconductor tape has a surface that forms an inner

surface of the third coiled superconductor tape. The inner surface of the third coiled superconductor tape faces the coil axis of the third coiled superconductor tape. The fourth coiled superconductor includes a superconductor layer and an electrically conductive layer. The electrically conductive layer of the fourth coiled superconductor tape has a surface that forms an outer surface of the fourth coiled superconductor tape. The outer surface of the fourth coiled superconductor tape faces away from the coil axis of the fourth coiled superconductor tape. The third and fourth coiled superconductor tapes are configured so that inner surface of the third superconductor tape is adjacent the outer surface of the fourth superconductor tape.

The architecture of the superconductor articles (e.g., tapes, cables and/or magnetic coils) can allow multiple superconductor layers to simultaneously be compressed (e.g., by being at or below the neutral mechanical axis) when the articles are bent.

The architecture of the superconductor articles (e.g., tapes, cables and/or magnetic coils) can reduce the risk of reduced current density due to, for example, the presence of defects (e.g., localized defects, such as a crack a grain boundary, or the like) in one or more of the superconductor layers.

The architecture of the superconductor articles (e.g., tapes, cables and/or magnetic coils) can result in current sharing through, for example, redundant conducting paths, lower hysteretic losses under alternating current conditions, enhanced electrical stability, and/or enhanced thermal stability.

The architecture of the superconductor articles (e.g., tapes, cables and/or magnetic coils) can result in a favorable stress profile and/or improved mechanical properties.

The architecture of the superconductor articles (e.g., tapes, cables, and/or magnetic coils) can provide improved mechanical stability, improved electrical stability, enhanced current carrying capacity, and/or favorable economy of manufacture.

The architecture of the superconductor articles (e.g., tapes, cables and/or magnetic coils) can reduce mechanical degradation of the operational superconductor layer(s) during bending.

The architecture of the superconductor articles (e.g., tapes, cables and/or magnetic coils) can make it relatively easy to splice the articles.

The architecture of the superconductor articles (e.g., tapes, cables and/or magnetic coils) can make it relatively easy to achieve termination of tape stack ups and/or conductor elements.

The architecture of the superconductor articles (e.g., tapes, cables and/or magnetic coils) can reduce heating due to, for example, localized defects in the superconductor material.

The superconductor articles (e.g., tapes, cables and/or magnetic coils) can be used in a variety of applications, including, for example, electrical, magnetic, electro-optic, dielectric, thermal, mechanical, and/or environmental (e.g., protective) applications.

Other features, objects, and advantages of the invention will be apparent from the description and drawings, and from the claims.

DESCRIPTION OF DRAWINGS

FIG. 1 is a cross-sectional view of an embodiment of a superconductor article including two superconductor tapes;

FIG. 2 is a cross-sectional view of an embodiment of the superconductor article of FIG. 1 when bent;

FIG. 3 is a plan view of an embodiment of a superconductor tape;

FIG. 4 is a cross-sectional view of the superconductor tape of FIG. 3;

FIG. 5A is a plan view of an embodiment of a superconductor tape;

FIG. 5B is a plan view of an embodiment of a superconductor tape;

FIG. 6 is a cross-sectional view of an embodiment of a superconductor tape; and

FIGS. 7A and 7B are perspective and plan views, respectively, of an embodiment of a superconductor magnetic coil.

Like reference symbols in the various drawings indicate like elements.

DETAILED DESCRIPTION

FIG. 1 shows a cross-sectional view of an embodiment of a superconductor article **1000** that includes multi-layer superconductor tapes **1100** and **1200**. Tape **1100** includes a substrate **1110**, a buffer layer **1120**, a superconductor layer **1130**, and an electrically conducting stabilizer layer **1140**. Similarly, tape **1200** includes a substrate **1210**, a buffer layer **1220**, a superconductor layer **1230**, and an electrically conducting stabilizer layer **1240**. The layers within tapes **1100** and **1200** are mechanically coupled (e.g., chemically bonded or metallurgically bonded) to their corresponding neighboring layers (e.g., mechanically coupled at points other than their ends), but tapes **1100** and **1200** are configured so that they can move independently of each other because, while stabilizer layers **1140** and **1240** contact each other and are in electrical communication, surface **440** of stabilizer layer **1140** is not mechanically coupled (e.g., is not chemically bonded or metallurgically bonded) to surface **470** of stabilizer layer **1240**.

With the architecture of article **1000**, electrical current can readily propagate along and between tapes **1100** and **1200**, even if a localized defect is present in superconductor layers **1130** and/or **1230**. For example, in the case that a localized defect (e.g., a crack, a grain boundary, or the like) is present in superconductor layer **1130**, electrical current in the vicinity of the defect can be shunted through stabilizer layers **1140** and **1240** and into superconductor layer **1230**. Likewise, if a localized defect is present in superconductor layer **1230**, electrical current in the vicinity of the defect can be shunted through stabilizer layers **1240** and **1140** and into superconductor layer **1130**. This can enhance both the electrical stability and/or the current carrying capacity of article **1000** compared to certain other superconductor articles in which the superconductor layers in neighboring tapes are not in electrical communication with each other.

Moreover, the architecture of article **1000** can provide enhanced electrical stability and/or enhanced current carrying capacity even in the absence of localized defects in one of superconductor layers **1130** and/or **1230** because these layers are in electrical communication with each other via stabilizer layers **1140** and **1240**, thereby increasing the volume of electrically conductive (including superconductive) material in electrical communication in article **1000** relative to other systems in which the superconductor layers of neighboring tapes are not in electrical communication with each other.

In addition, by allowing tapes **1100** and **1200** to move independently of each of other, tapes **1100** and **1200** can be

designed so that, when exposed to certain conditions of stress (e.g., when bent, such as when formed in a cable or a magnetic coil), they each have their own neutral mechanical axis (i.e., lowest strain region). This is shown, for example, in FIG. 2 where tapes **1100** and **1200** are bent. Tape **1100** has a neutral mechanical axis **1150**, and tape **1200** has a neutral mechanical axis **1250**. Without wishing to be bound by theory, it is believed that superconductor layers **1130** and **1230** have a higher critical current density when compressed than when expanded. Because tapes **1100** and **1200** have independent neutral mechanical axes, tapes **1100** and **1200** can be designed so that, when bent, superconductor layers **1130** and **1230** are located at or below neutral mechanical axes **1150** and **1250**, respectively. This allows superconductor layers **1130** and **1230** to simultaneously be in a compressed state when tapes **1100** and **1200** are bent.

In some embodiments, the distance the superconductor layer is from the neutral mechanical axis is less than about 10 percent (e.g., less than about nine percent, less than about eight percent, less than about seven percent, less than about six percent, less than about five percent, less than about four percent, less than about three percent, less than about two percent, less than about one percent) of the thickness of the tape.

In certain embodiments, the thickness of the layers in tapes **1100** and/or **1200** can be selected so that, when tapes **1100** and/or **1200** are bent, superconductor layers **1130** and/or **1230**, respectively, are at or below neutral mechanical axes **1150** and/or **1250**, respectively. As an example, in some embodiments, the thickness of substrate **1110** is about the same as or greater than the combined thickness of the of stabilizer layer **1140**, superconductor layer **1130** and buffer layer **1120**. For example, the thickness of substrate **1110** can be at least about one percent greater (e.g., at least about two percent greater, at least about three percent greater, at least about four percent greater, at least about five percent greater, at least about eight percent greater, at least about 10 percent greater) than the combined thickness layers **1140**, **1130** and **1120**. As another example, in certain embodiments, the thickness of stabilizer layer **1240** is about the same as or greater than the combined thickness of the of substrate **1210**, buffer layer **1220**, and superconductor layer **1230**. For example, the thickness of layer **1240** can be at least about one percent greater (e.g., at least about two percent greater, at least about three percent greater, at least about four percent greater, at least about five percent greater, at least about eight percent greater, at least about 10 percent greater) than the combined thickness layers **1210**, **1220** and **1230**.

In some embodiments, layer **1110** is from about 20 microns to about 80 microns thick (e.g., from about 30 microns to about 70 microns thick, from about 40 microns to about 60 microns thick, about 50 microns thick).

In certain embodiments, layer **1120** is from about 0.1 micron to about 0.5 micron thick (e.g., from about 0.2 micron to about 0.4 micron thick, about 0.3 micron thick).

In some embodiments, layer **1130** is from about 0.7 micron to about 1.3 microns thick (e.g., from about 0.8 micron to about 1.2 microns thick, from about 0.9 micron to about 1.1 microns thick, about one micron thick).

In certain embodiments, layer **1140** is from about 45 microns to about 51 microns thick (e.g., from about 46 microns to about 50 microns thick, from about 47 microns to about 49 microns thick, about 48.7 microns thick).

In some embodiments, layer **1210** is from about 20 microns to about 80 microns thick (e.g., from about 30 microns to about 70 microns thick, from about 40 microns to about 60 microns thick, about 50 microns thick).

In certain embodiments, layer **1220** is from about 0.1 micron to about 0.5 micron thick (e.g., from about 0.2 micron to about 0.4 micron thick, about 0.3 micron thick).

In some embodiments, layer **1230** is from about 0.7 micron to about 1.3 microns thick (e.g., from about 0.8 micron to about 1.2 microns thick, from about 0.9 micron to about 1.1 microns thick, about one micron thick).

In certain embodiments, layer **1240** is from about 48 microns to about 53 microns thick (e.g., from about 49 microns to about 52 microns thick, from about 50 microns to about 52 microns thick, about 51.3 microns thick).

Substrates **1110** and **1210** are typically formed of conventional substrate materials. Such materials include, for example, metals and alloys, such as nickel, silver, copper, zinc, aluminum, iron, chromium, vanadium, palladium, molybdenum or their alloys.

Buffer layers **1120** and **1220** are generally formed of conventional buffer layer materials. Examples of such materials include metals, metal oxides and/or metal oxides, such as silver, nickel, CeO_2 , Y_2O_3 , ThO_x , GaO_x , yttria stabilized zirconia (YSZ), LaAlO_3 , SrTiO_3 , Gd_2O_3 , LaNiO_3 , LaCuO_3 , SrTiO_3 , NdGaO_3 , NdAlO_3 , MgO , AlN , NbN , TiN , VN and ZrN .

In general, superconductor layers **1130** and **1240** are formed of rare earth oxide superconductor materials. Examples of such materials include rare earth copper oxide superconductors, such as rare earth barium copper oxides (e.g., YBCO, GdBCO and ErBCO).

Typically, the substrate/buffer layer/superconductor layer arrangement in tapes **1100** and **1200** is formed via epitaxial growth. Accordingly, surfaces **432**, **434** and **436** of substrate **1110**, buffer layer **1120** and superconductor layer **1130**, respectively, are usually textured (e.g., biaxially textured or cube textured). Similarly, surfaces **484**, **482** and **470** of substrate **1210**, buffer layer **1220** and superconductor layer **1230**, respectively, are usually textured (e.g., biaxially textured or cube textured).

Stabilizer layers **1140** and **1240** are generally formed of electrically conductive materials, such as metals and/or alloys. Examples of materials from which layers **1140** and **1240** can be formed include copper, nickel, silver and alloys thereof.

Generally, a tape has a length dimension that is substantially greater than its width or breadth. Exemplary dimensions are micrometers to hundreds of micrometers in height (e.g., at least one micrometer, at least two micrometers, at least five micrometers, at least 10 micrometers, at least 20 micrometers, at least 50 micrometers, at least 100 micrometers, at least 200 micrometers, at least 1000 micrometers), millimeters to centimeters in width (e.g., at least one millimeter, at least two millimeters, at least five millimeters, at least 10 millimeters, at least 20 millimeters), and fractions of a meter to thousands of meters in length (e.g., at least 0.01 meter, at least 0.2 meters, at least 0.1 meters, at least 1 meter, at least 10 meters, at least 100 meters).

In some embodiments, superconductor tapes **1100** and **1200** can be included in superconductor cables. FIGS. 3 and 4 show plan and cross-sectional views, respectively, of a portion of an embodiment of a superconductor cable **400** in which a layer **404** of cable **400** is formed from superconductor tape **1100** and a layer **406** of cable **400** is formed from superconductor tape **1200**. Tapes **1100** and **1200** are configured to move relatively independent of each other (e.g., they are not mechanically coupled to each other). Tape **1100** is helically wound around a helical axis **420** so that surface **430**

of tape **1100** faces toward helical axis **420** and surface **440** of tape **1100** faces away from helical axis **420**. The helix formed by tape **1100** has a helical pitch **450**, which corresponds to the distance along helical axis **420** in which tape **1100** is wound through 360° . Generally, pitch **450** can be varied as desired. As an example, pitch **450** can be about equal to the width of tape **1100** so that alternate windings of tape **1100** are adjacent each other. As another example, pitch **450** can be much longer or shorter than the width of tape **1100**.

Tape **1200** is helically wound over the tape **1100** and around helical axis **420** in the opposite direction to tape **1100**. Tape **1200** is wound with surface **470** facing toward helical axis **420** and surface **480** facing away from helical axis **420**. Tape **1200** has a helical pitch **490** which can generally be varied as desired. As an example, helical pitch **490** can be about equal to the width of tape **1200** so that alternate windings of tape **1200** are adjacent each other. Helical pitch **490** can be about the same as, shorter than, or longer than helical pitch **450**.

Surface **470** of tape **1200** contacts surface **440** of tape **1100** periodically along the cable at points **499**. Points **499** typically are points of electrical communication between tapes **1100** and **1200**, allowing electrical current to pass between tapes **1100** and **1200** via stabilizer layers **1140** and **1240**.

Referring to FIG. 4, cable **400** can be formed by winding tapes **1100** and **1200** around a forming element **401**. Optionally, forming element **401** can be removed after winding, or can remain as a structural component of cable **400**. Optionally or additionally, forming element **401** can be used to supply a cryogenic fluid to cable **400** in order to cool tapes **1100** and/or **1200** (e.g., to a temperature that is about the same as or below the critical temperature of superconductor layers **1130** and/or **1230**).

While embodiments have been described in which each layer of a superconductor tape is formed by a helically winding a single tape around a helical axis in a given direction, the invention is not so limited.

As an example, more than one (e.g., two, three, four, five, six, seven, eight, etc.) superconductor tapes can be helically wound beside each other in the same direction around a helical axis to form a layer of a superconductor tape. FIG. 5A is a plan view of an embodiment of a layer of a cable **500** that includes two superconductor tapes **1100a** and **1100b** that are helically wound beside each other about a helical axis **520** in the same direction. FIG. 5B is a plan view of an embodiment of a superconductor cable **800**, including four tapes **810**, **820**, **830**, and **840**. Two tapes, **810** and **820**, are wound in a first helical direction around a forming element **801**. Tape **810** and tape **820** are wound parallel. Two additional tapes, **830** and **840**, are wound in a second helical direction, opposite the first helical direction, around forming element **801** on top of tapes **810** and **820**. Tapes **830** and **840** are wound parallel. The number of superconductor tapes helically wound beside each other in each layer of a superconductor cable can be the same as or different than the number of superconductor tapes helically wound beside each other in the other layers of the superconductor cable. In some embodiments, one layer of a superconductor cable may be formed of a single tape while one or more other layers of the superconductor cable may be formed of multiple tapes wound beside each other.

As another example, more than one (e.g., two, three, four, five, six, seven, eight, etc.) superconductor tapes can be stacked on top of each other and then helically wound

around a helical axis in the same direction to form a layer of a superconductor tape. In such embodiments the superconductor tapes are stacked so that the tapes form pairs in which the stabilizer layers contact each other. FIG. 6 shows an embodiment of a layer of a cable **600** that is formed of two superconductor tapes **1100** and **1200** that are stacked on each other and helically wound around a helical axis **620** in the same direction. The number of superconductor tapes stacked on each other in each layer of superconductor cable **600** can be the same as or different than the number of superconductor tapes that are stacked on each other in the other layers of cable **600**. Optionally, a layer of electrically insulating material can be wound positioned between tapes **1100** and **1200**.

In some embodiments, cables having sufficient current transfer terminations can be relatively easily fabricated and the overall current density of the cable can be relatively high. As an example, the current density can be greater than about 6000 Amperes.

In certain embodiments, one or more of the tapes in a superconductor cable can have an electrically conductive stabilizer layer with a free surface, and the tape layers can be separated at the cable ends to expose the free surfaces. In some embodiments, one or more of the exposed free surface of the stabilizer layer(s) can be used as a terminal for current transfer into and/or out of the superconductor tape.

While the superconductor tapes described herein have been discussed with respect to their use in superconductor cables, the superconductor tapes can also be used in other applications, such as, for example, superconductor coils (e.g., magnetic coils). FIGS. 7A and 7B show perspective and plan views, respectively, of a superconductor coil **600** including multiple turns (**710**, **715**, **720**, **725**, etc.) wound around coil axis **630** with each turn formed by superconductor tapes **1100** and **1200**. Tapes **1100** and **1200** are generally not mechanically coupled, but may be mechanically coupled at their respective ends. In each turn of coil **600**, surface **440** of tape **1100** contacts surface **470** of tape **1200** so that tapes **1100** and **1200** are in electrical communication. In addition, in adjacent turns of coil **600**, surface **430** of tape **1100** contacts surface **480** of tape **1200** in the adjacent turn. In some embodiments, one or more materials (e.g., an electrically insulating material, such as an electrically insulating cloth) may be coiled between adjacent turns (e.g., between surfaces **430** and **480** of adjacent turns).

While embodiments of a superconductor coil having each turn formed of one superconductor tape pair have been described, the invention is not so limited. In general, a superconductor coil can have each turn formed of any desired number of superconductor tape pairs (e.g., two tape pairs, four tape pairs, six tape pairs, eight tape pairs, etc.). Typically, each tape pair within a turn is configured so that the stabilizer layers contact each other, so that the tapes within each tape pair are in electrical communication, and so that the substrates of adjacent tape pairs contact each other.

While the foregoing description has been with respect to superconductor tapes that include certain layers (substrate, buffer layer, superconductor layer, and stabilizer layer), the invention is not limited in this sense. A superconductor tape can include additional layers. In these embodiments, the layers are preferably arranged so that the superconductor layer(s) are below the neutral mechanical axis of the tape. In some embodiments, this can be achieved by using a stabilizer having a thickness that is about the same or greater than the combined thickness of the other layers in the tape. In certain embodiments, this can be achieved by using a

substrate having a thickness that is about the same or greater than the combined thickness of the other layers in the tape.

In some embodiments, a superconductor tape can include more than one buffer layer (e.g., two buffer layers, three buffer layers, four buffer layers, etc.). The multiple buffer layers can be stacked on top of each other. In certain embodiments, a superconductor tape can include more than one superconductor layer. The multiple superconductor layers can be stacked on top of each other. A superconductor tape can include intercalated buffer layers and superconductor layers.

In some embodiments, a superconductor tape can include a cap layer between the superconductor layer and the stabilizer layer. The cap layer can, for example, be formed of an electrically conductive material that is less reactive with the superconductor material than the material from which the stabilizer layer is formed. Examples of material from which the solder can be formed include silver, gold, palladium and platinum.

In certain embodiments, a superconductor tape can include a solder layer between the cap layer and the stabilizer layer. The solder layer can, for example, assist in adhesion between the cap and stabilizer layers. Examples of materials from which the solder layer can be formed include certain lead-tin based solders (e.g., a solder containing about 62% lead, about 36% tin and about two percent silver, or a solder containing about 95% lead about five percent tin). Other appropriate solders are known to those skilled in the art.

In addition, while superconductor articles have been described in which the stabilizer layers of adjacent tapes are in contact, other embodiments are also possible. More generally, the stabilizer layers need not be in contact, but are preferably in electrical communication and arranged so that each tape has its own neutral mechanical axis. For example, a layer of material, such as a layer of an electrically conductive material that reduces friction between the adjacent stabilizer layers and/or a layer of an electrically conductive material that reduces oxidation of one or both of the adjacent stabilizer layers, can be located between the adjacent stabilizer layers. In some embodiments, a layer of graphite can be positioned between adjacent stabilizer layers. In certain embodiments, molybdenum disulfide can be positioned between adjacent stabilizer layers. In some embodiments, one or more adjacent stabilizer layers can contain (e.g., be impregnated with) an appropriate lubricant material, such as one or more greases (e.g., one or more electrically conductive greases). In certain embodiments, a hard layer (e.g., a thin, hard layer) of material (e.g., electrically conductive material, such as chrome, nickel and/or certain nitride materials) can be disposed between adjacent stabilizers (e.g., formed as an additional layer on top of one or both stabilizer layers).

In certain embodiments (e.g., when a tape is configured so that the stabilizer layer is facing the helical axis), the thickness of the is stabilizer is about the same or greater than the combined thickness of the substrate, buffer and superconductor layers. In some embodiments (e.g., when a tape is configured so that the stabilizer layer is facing away from the helical axis), the thickness of the is stabilizer is about the same or less than the thickness of the substrate less the thickness of the buffer layers less the thickness of the superconductor layers.

In general, when two layers are mechanically coupled, they can be mechanically coupled at points other than their ends. As an example, they can be mechanically coupled

along the entire surfaces of contact. As another example, they can be intermittently mechanically coupled at points along their surfaces.

Other embodiments are in the claims.

What is claimed is:

1. An article comprising:

a first superconducting tape, comprising:

a first substrate;

a first layer comprising a first superconductor material; and

a second layer comprising a first electrically conductive material,

wherein the first layer is between the first substrate and the second layer, and the second layer is mechanically coupled to the first layer so that, when bent, the the first superconducting tape has a first neutral mechanical axis; and

a second superconducting tape, comprising:

a second substrate;

a third layer comprising a second superconductor material; and

a fourth layer comprising a second electrically conductive material,

wherein the third layer is between the second substrate and the fourth layer, and the fourth layer is mechanically coupled to the third layer, so that, when bent, the second superconducting tape has a second neutral mechanical axis different than the first neutral mechanical axis, and

wherein the second and fourth layers are in electrical communication.

2. The article of claim 1, wherein the first superconductor material comprises a first rare earth metal oxide superconductor and the second superconductor material comprises a second rare earth metal oxide superconductor.

3. The article of claim 2, wherein the first and second rare earth metal oxide superconductors are the same.

4. The article of claim 3, wherein the first and second rare earth metal oxide superconductors comprise YBCO.

5. The article of claim 1, wherein the first electrically conductive material comprises a first metal and the second electrically conductive material comprises a second metal.

6. The article of claim 5, wherein the first and second metals are the same.

7. The article of claim 6, wherein the first and second metals comprise copper.

8. The article of claim 1, wherein the first and second layers are in the form of a first tape, and the third and fourth layers are in the form of a second tape.

9. The article of claim 1, further comprising first and second buffer layers, wherein the first buffer layer is between the first substrate and the first layer, and the second buffer layer is between the second substrate and the third layer.

10. The article of claim 9, wherein the first substrate layer has a thickness that is about equal to a combined thickness of the first layer, the first buffer portion, and the second layer.

11. The article of claim 10, wherein the fourth layer has a thickness that is about equal to a combined thickness of the third layer, the second buffer portion, and the second substrate layer.

12. The article of claim 1, further comprising first and second cap layers, wherein the first cap layer is between the first and second layers, and the second cap layer is between the third and fourth layers.

13. The article of claim 1, further comprising an interfacial layer between the second and fourth layers, wherein the

interfacial layer comprises a third electrically conductive material that reduces oxidation of the second and fourth layers.

14. The article of claim 1, further comprising an interfacial layer between the second and fourth layers, wherein the interfacial layer comprises a third electrically conductive material that reduces friction between the second and the fourth layer.

15. The article of claim 1, further comprising a layer of graphite between the second and fourth layers.

16. The article of claim 1, wherein the article is configured so that the second and fourth layers can move independently of each other.

17. An article comprising:

a first helically wound superconductor tape that includes a substrate, a superconductor layer and an electrically conductive layer, the superconductor layer of the first helically wound superconductor tape being between the substrate of the first helically wound superconductor tape and the electrically conductive layer of the first helically wound superconductor tape having a first neutral mechanical axis when bent; and

a second helically wound superconductor tape that includes a substrate, a superconductor layer and an electrically conductive layer, the superconductor layer of the second helically wound superconductor tape being between the substrate of the second helically wound superconductor tape and the electrically conductive layer of the second helically wound superconductor tape having a second neutral mechanical axis when bent, the second neutral mechanical axis being different than the first neutral mechanical axis,

wherein the electrically conductive layers of the first and second superconductor tapes are in electrical communication.

18. The article of claim 17, wherein the first and second superconductor layers comprise a rare earth metal oxide superconductor.

19. The article of claim 18, wherein the rare earth metal oxide superconductor comprises YBCO.

20. The article of claim 17, wherein the first and second electrically conductive layers comprise a metal.

21. The article of claim 20, wherein the metal comprises copper.

22. The article of claim 17, further comprising a forming element, wherein the first and second superconductor tapes are helically wound around the forming element.

23. The article of claim 17, wherein the superconductor layers of the first and second superconductor tapes are mechanically compressed.

24. The article of claim 17, wherein the first superconductor tape further includes a buffer layer and the second superconductor tape further includes a buffer layer, the buffer layer of the first superconductor tape being between the substrate of the first superconductor tape and the superconductor layer of the first superconductor tape, and the buffer layer of the second superconductor tape being between the substrate of the second superconductor tape and the superconductor layer of the second superconductor tape.

25. The article of claim 17, wherein the first superconductor tape further includes a cap layer and the second superconductor tape further includes a cap layer, the cap layer of the first superconductor tape being between the superconductor layer of the first superconductor tape and the electrically conductive layer of the first superconductor tape, and the cap layer of the second superconductor tape being between the superconductor layer of the second superconductor tape and the electrically conductive layer of the second superconductor tape.

26. The article of claim 17, further comprising an interfacial layer between the second and fourth layers, wherein the interfacial layer comprises a third electrically conductive material that reduces oxidation of the second and fourth layers.

27. The article of claim 17, further comprising an interfacial layer between the second and fourth layers, wherein the interfacial layer comprises a third electrically conductive material that reduces friction between the second and the fourth layer.

28. The article of claim 17, further comprising a layer of graphite between the second and fourth layers.

29. The article of claim 17, wherein the article is configured so that the first and second helically wound superconductor tapes can move independently of each other.

30. The article of claim 17, wherein the first and second helically wound superconductor tapes have a common helical axis.

31. The article of claim 17, further comprising:

a third helically wound superconductor tape that includes a substrate, a superconductor layer and an electrically conductive layer, the superconductor layer of the third helically wound superconductor tape being between the substrate of the third helically wound superconductor tape and the electrically conductive layer of the third helically wound superconductor tape; and

a fourth helically wound superconductor tape that includes a substrate, a superconductor layer and an electrically conductive layer, the superconductor layer of the fourth helically wound superconductor tape being between the substrate of the fourth helically wound superconductor tape and the electrically conductive layer of the fourth helically wound superconductor tape,

wherein the electrically conductive layers of the third and fourth superconductor tapes have more than one point of electrical communication.

32. The article of claim 31, wherein the third and fourth helically wound superconductor tapes have a common helical axis.

33. The article of claim 17, wherein the article is in the form of a cable.

34. The article of claim 17, wherein the electrically conductive layers of the first and second superconductor tapes at least partially overlap.

35. The article of claim 17, wherein the electrically conductive layers of the first and second superconductor tapes substantially entirely overlap.