



US006739887B1

(12) **United States Patent**  
**Yu**

(10) **Patent No.:** **US 6,739,887 B1**  
(45) **Date of Patent:** **May 25, 2004**

(54) **SECURITY DEVICE OF POWER RECEPTACLE**

(76) Inventor: **Tsung-I Yu**, No. 209, Sec. 3, County Boulevard, Pan Chiao City, Taipei (TW)

(\*) Notice: Subject to any disclaimer, the term of this patent is extended or adjusted under 35 U.S.C. 154(b) by 0 days.

(21) Appl. No.: **10/611,974**

(22) Filed: **Jul. 3, 2003**

(51) **Int. Cl.**<sup>7</sup> ..... **H01R 13/44**

(52) **U.S. Cl.** ..... **439/137**

(58) **Field of Search** ..... 439/137, 135, 439/145

(56) **References Cited**

**U.S. PATENT DOCUMENTS**

4,729,741 A \* 3/1988 Peng ..... 439/137

5,391,085 A \* 2/1995 Tigner ..... 439/137

5,915,981 A \* 6/1999 Mehta ..... 439/137

\* cited by examiner

*Primary Examiner*—Tho D. Ta

*Assistant Examiner*—James R. Harvey

(74) *Attorney, Agent, or Firm*—Bacon & Thomas, PLLC

(57) **ABSTRACT**

A security device for a power receptacle. The device includes a slot cover, a protection cover, and elastic elements. A surface of the slot cover is formed with slots. At least two recesses penetrate into the interior of the receptacle. An inner lateral surface of at least one recess is installed with a positioning block. The protection cover is a sheet body with holes on a surface thereof. At least two hooking sheets are installed at an inner surface of the protection cover. At least one hooking sheet is installed with a fixing block. The hooking sheets of the protection cover can be movably engaged to the recesses of the slot cover. The elastic elements are positioned between the positioning blocks and fixing blocks. The protection cover is movable and restorable due to the elasticity of the elastic elements.

**7 Claims, 6 Drawing Sheets**

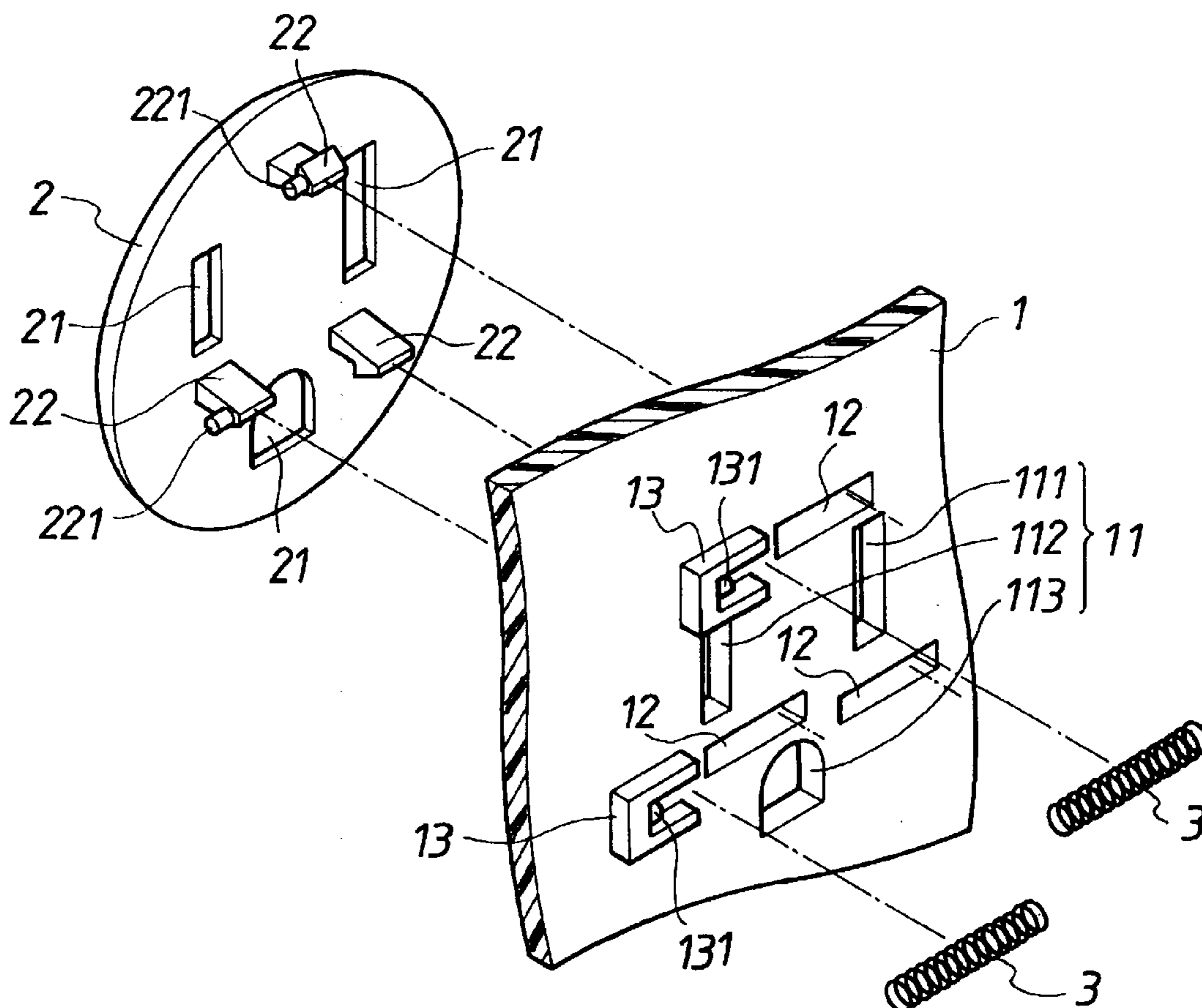

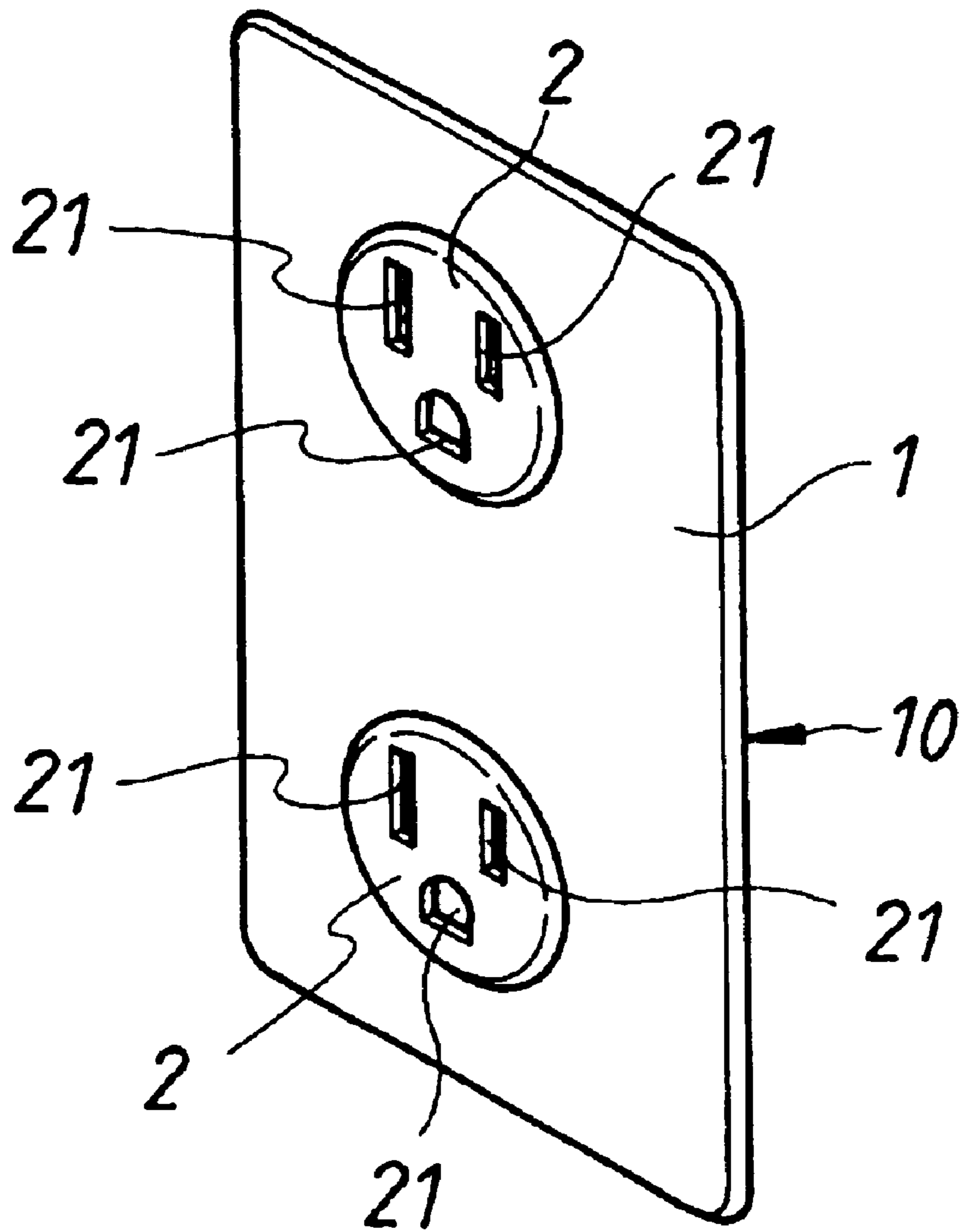

**FIG.1**

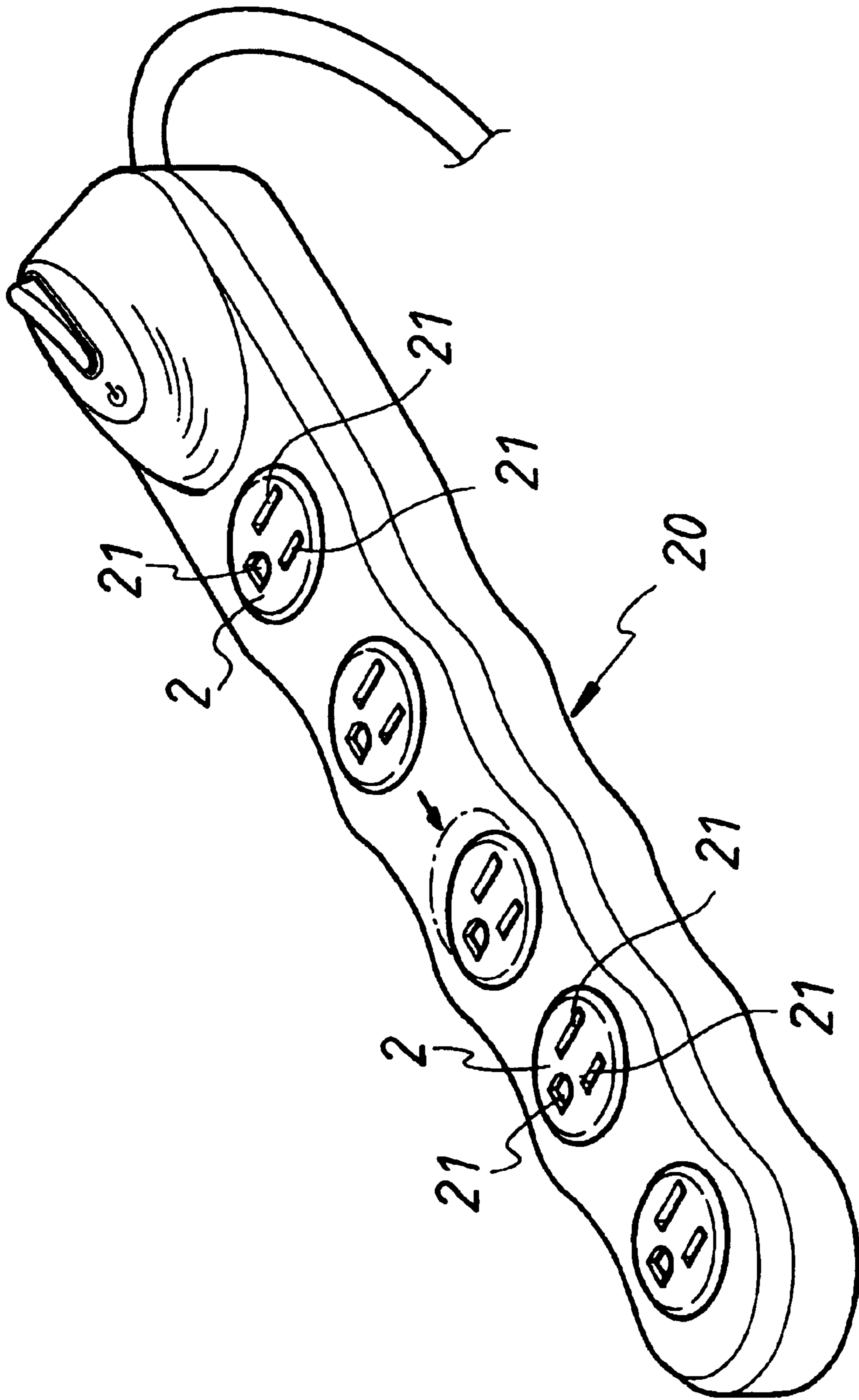

FIG. 2

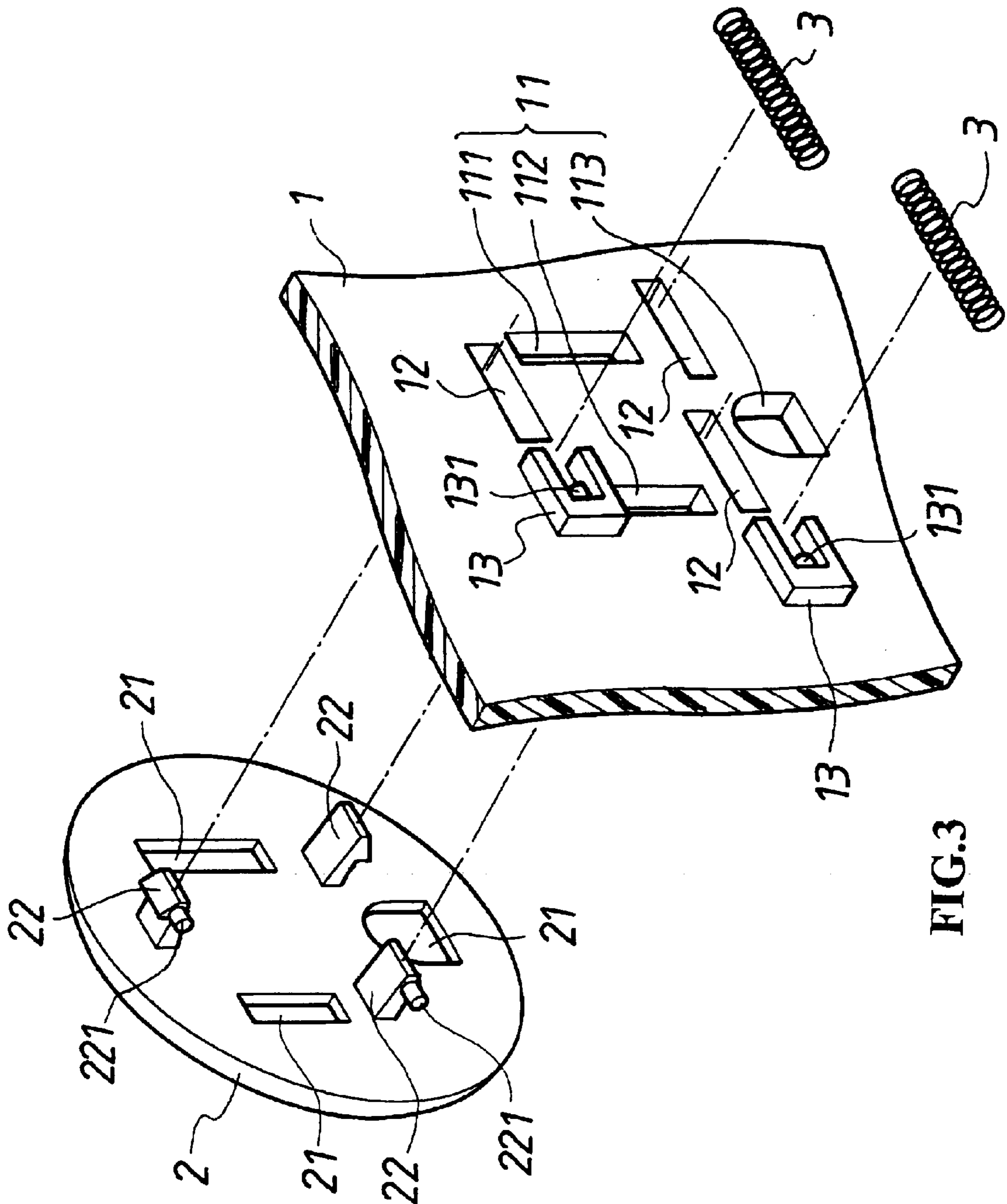

FIG. 3

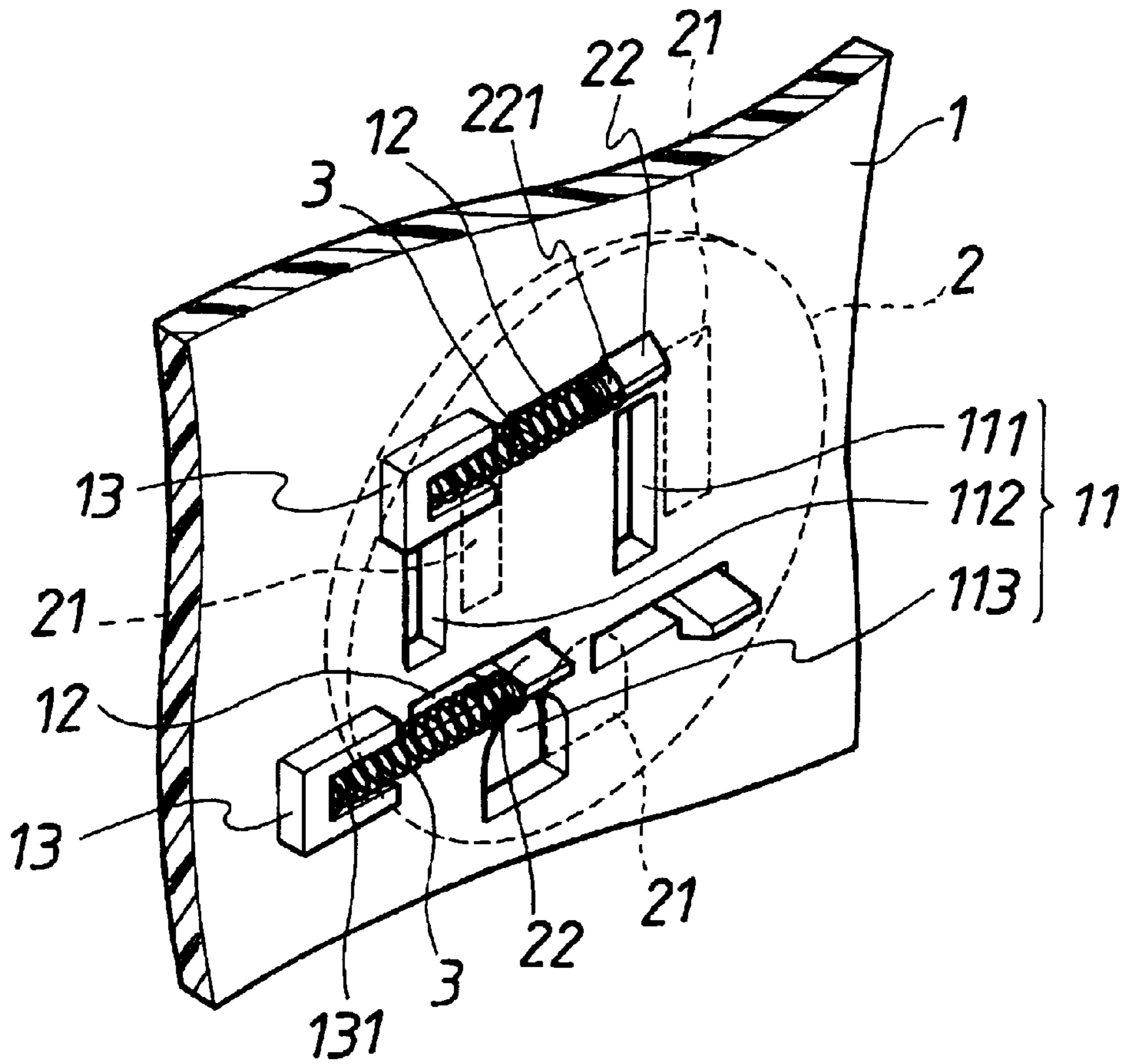

FIG. 4

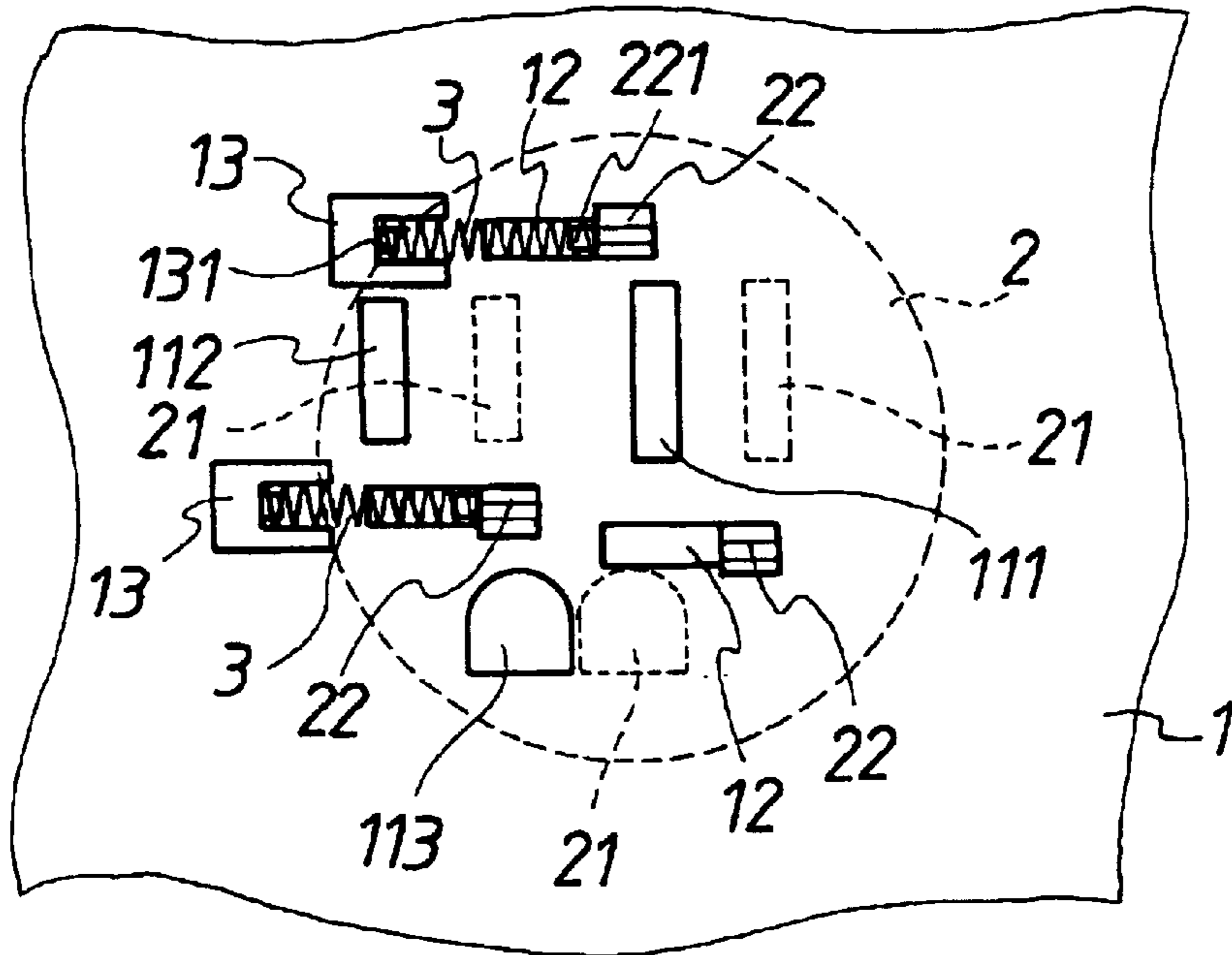

FIG. 5

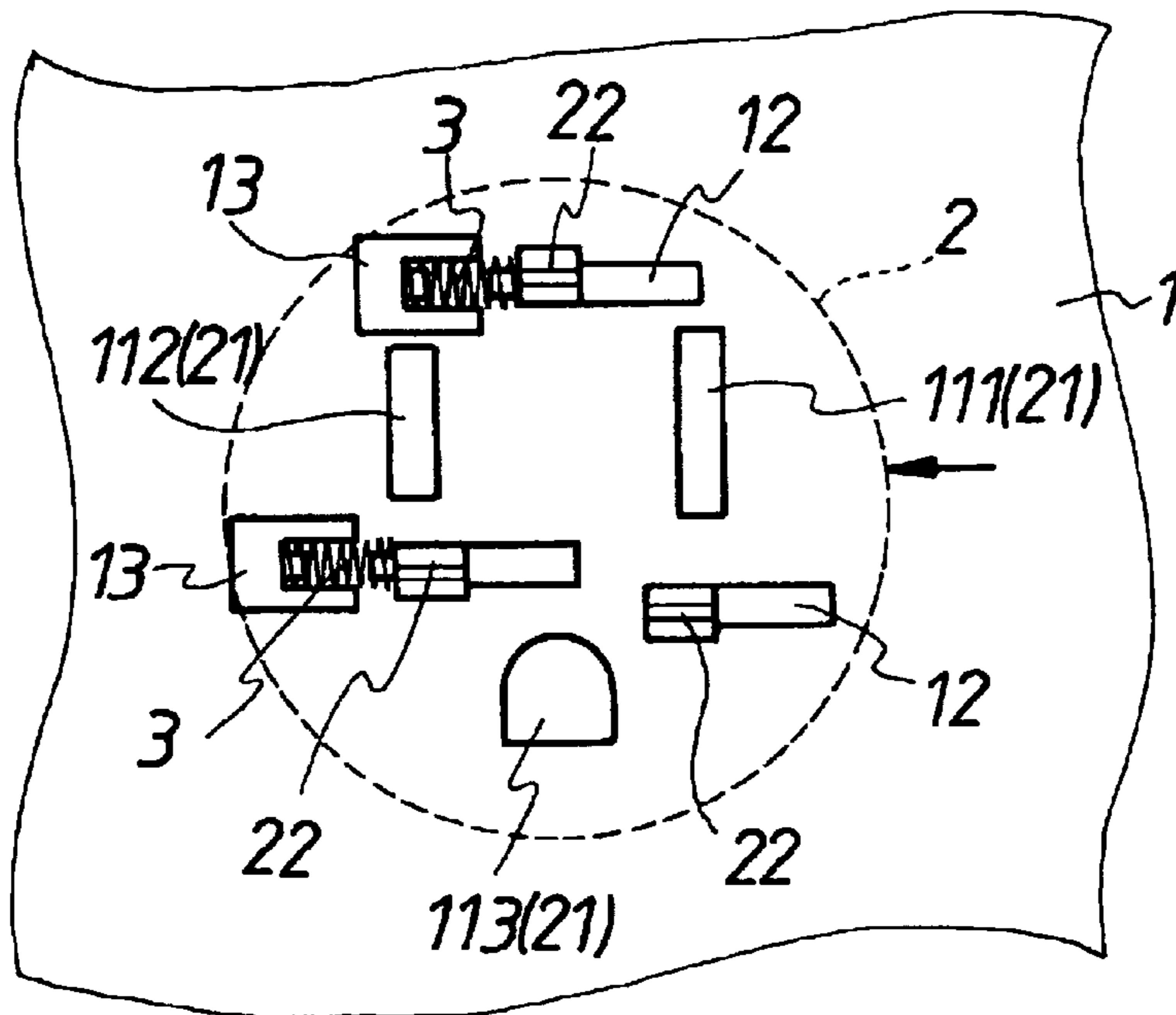

FIG. 6

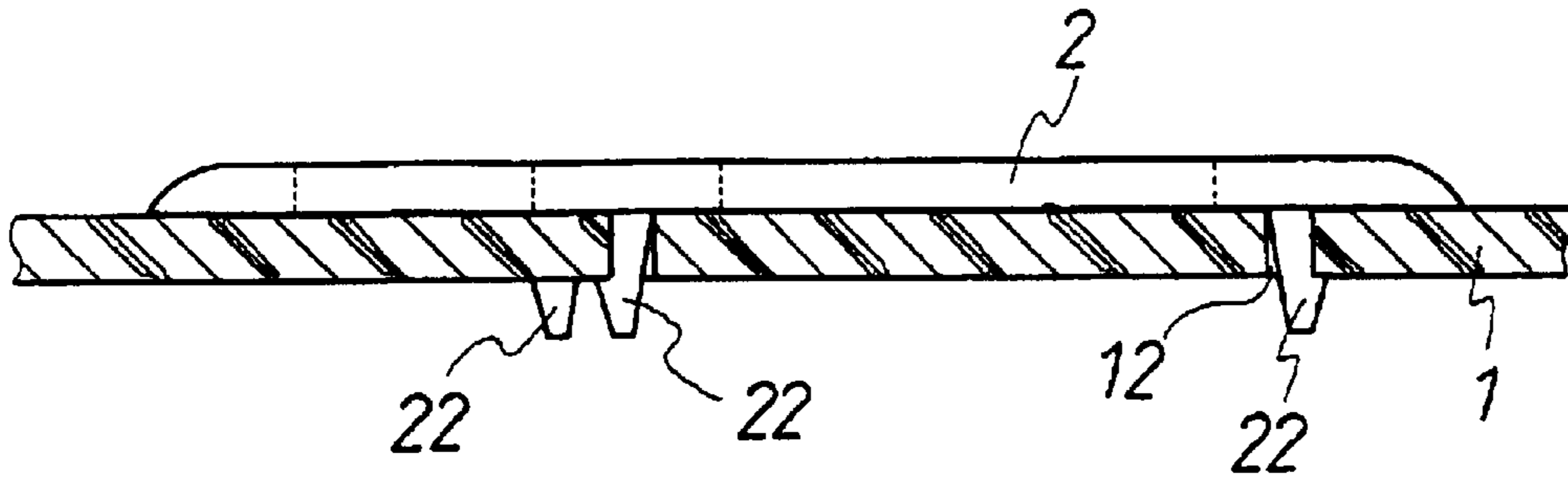

FIG. 7

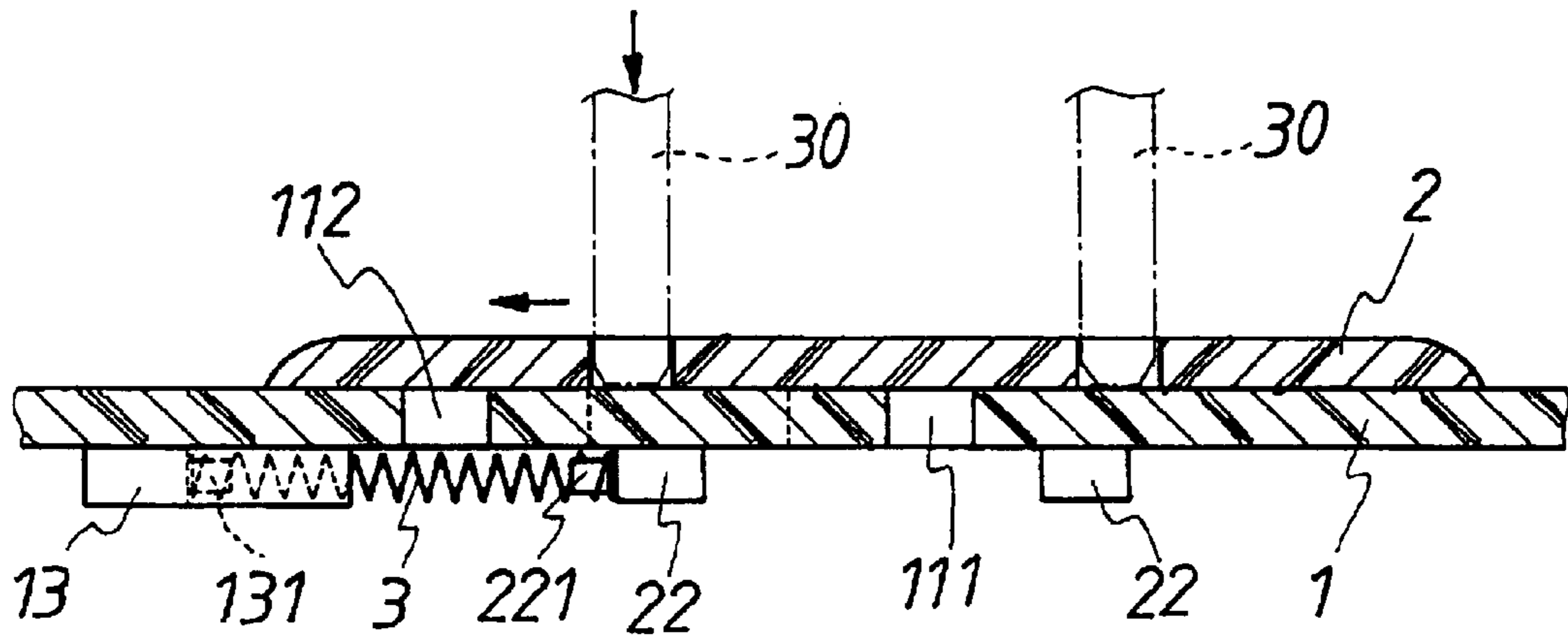

FIG. 8

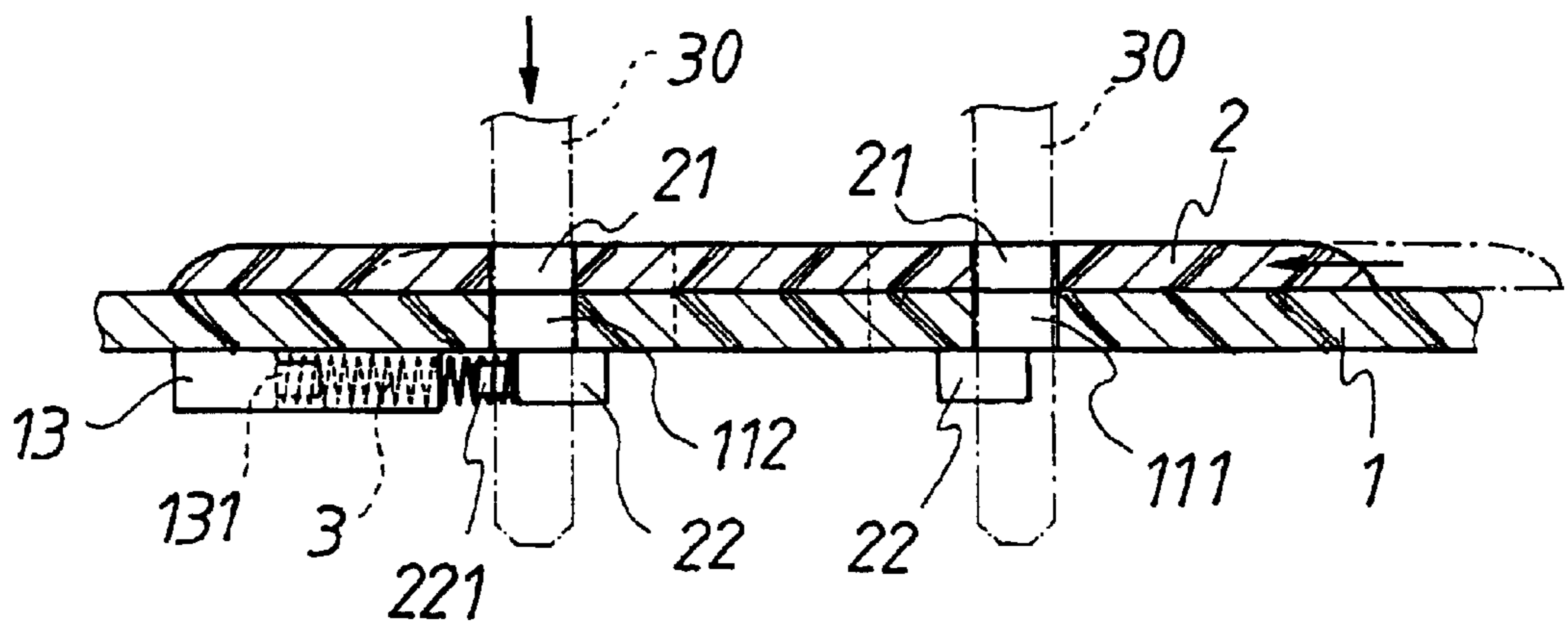

FIG. 9

## SECURITY DEVICE OF POWER RECEPTACLE

### BACKGROUND OF THE INVENTION

#### (a) Field of the Invention

The present invention relates to security devices, and particularly to a security device of a power receptacle applied to slots of a wall receptacle or an extension line receptacle. Normally, the present invention seals the slots of a slot cover for preventing the intrusion of undesired objects. Furthermore, a plug can be pushed into the slot for power conduction.

#### (b) Description of the Prior Art

Conventionally, the slots of a receptacle are aligned to the conductive sheets in the receptacle. Plugs can be inserted into the receptacle rapidly and conveniently. However, this conventional structure easily induces accidents, namely electric shocks. This is because in general, fixed-type receptacles are placed about one foot away from the ground floor and the plugs of the extension lines are placed on the ground randomly, and it is very possible for children to insert objects, such as screws, nails, or tools, into the slots of the receptacles, so as to induce electric shock. Moreover, since the slots are conductive to the conductive arms or plugs, dust or insects will easily enter into the slots so as to affect the quality of the receptacle, and even the conductive arms will be oxidized. There is an eager demand for novel security devices used in power receptacles which can improve the prior art.

### SUMMARY OF THE INVENTION

Accordingly, the primary object of the present invention is to provide a security device of a power receptacle which comprises a slot cover, a protection cover and a plurality of elastic elements. The slot cover is a cover installed on a receptacle. A surface of the slot cover is formed with at least one power slot set. A surface of the power slot set has at least two recesses penetrating to an interior of the receptacle. At least one recess in an inner surface of the slot cover is installed with a positioning block at a lateral side thereof. A protection cover serves for isolating the sheets of slots of the slot cover. A surface thereof is installed with a plurality of holes corresponding to the slots. An inner surface thereof is installed with a plurality of slots corresponding to a plurality of hooking arms corresponding to the recesses of the protection cover. At least one hooking arm is installed with the fixing block at a lateral side thereof. A plurality of elastic elements allow the protection cover to isolate the elements of the slots. Thereby, the hooking arms at the inner surface of the protection cover are inserted into the recesses of the slot cover. The recesses of the slot cover can not be guided to move linearly. The elastic elements are installed between the positioning blocks of the slot cover and the fixing blocks of the hooking sheets. The elastic elements resist against the protection cover. As a result, the protection cover will seal the slots; and moreover, after moving the protection cover, the holes of the protection cover will align to the slots of the slot cover.

The various objects and advantages of the present invention will be more readily understood from the following detailed description when read in conjunction with the appended drawing.

### BRIEF DESCRIPTION OF THE DRAWINGS

FIG. 1 is a schematic perspective view showing the present invention as applied to a wall receptacle.

FIG. 2 is a schematic perspective view showing the present invention as applied to an extension line receptacle.

FIG. 3 is an exploded rear view of the present invention.

FIG. 4 is an assembled rear view of the present invention.

FIG. 5 is a rear view showing the protection cover of the present invention cover upon the receptacle.

FIG. 6 is a rear view showing the protection cover moving linearly.

FIG. 7 is a schematic view showing the protection cover engaged to the slot cover according to the present invention.

FIG. 8 is a schematic view showing the operation of the plug according to the present invention.

FIG. 9 is another schematic view showing the operation of the plug according to the present invention.

### DETAILED DESCRIPTION OF THE PREFERRED EMBODIMENTS

Referring to FIG. 4, the security device of a power receptacle of the present invention is illustrated. The security device of a power receptacle includes a slot cover **1**, a protection cover **2**, a plurality of elements **3**. The slot cover **1** is installed on a wall receptacle **10** (referring to FIG. 1) or an extension line receptacle **20** (referring to FIG. 2). The shape of the wall receptacle **10** or the extension line receptacle **20** is not confined in the present invention. A surface of the slot cover **1** is installed with at least one power slot set **11**. The power slot set **11** includes at least one live wire slot **111**, a ground wire slot **112**, and a grounding slot **113**. In the present invention, on a surface of the power slot set **11** has at least two long recesses **12** penetrating to an interior of the receptacle (referring to FIG. 3, in FIG. 3, three slots are the illustrated). At least one recess **12** in an inner surface of the slot cover **1** is installed with a positioning block **13** at a lateral side thereof (referring to FIG. 3, in this embodiment, there are two positioning blocks **13** are illustrated). The positioning block **13** has a U shape and an interior thereof has a post **131**.

The protection cover **2** (see FIG. 3) serves to isolate the openings of the live wire slot **111**, ground wire slot **112** and grounding slot **113**. The protection cover **2** can be in the shape of a round sheet. A surface thereof is formed with two or three holes **21** corresponding to the live wire slot **111**, ground wire slot **112** and grounding slot **113**. An inner surface thereof is formed with recesses **22** corresponding to hooking arms **22** corresponding to the recesses **12** of the protection cover **2**. At least one hooking arm **22** is installed with the fixing block **221** at a lateral side thereof. The fixing block **221** may be formed as a post.

The elastic element **3** causes that the protection cover **2** to isolate the elements of the live wire slot **111**, ground wire slot **112**, and grounding slot **113** in normal condition. The element **3** can be a helical compressible spring (referring to FIG. 3).

Thereby, referring to FIGS. 4, 5 and 7, the hooking arms **22** at the inner surface of the protection cover **2** are inserted into the recesses **12** of the slot cover **1**. The slot cover **1** can not be guided by the recesses **12** to move linearly. The elastic elements **3** are installed between the positioning blocks **13** of the slot cover **1** and the fixing blocks **221** of the hooking arms **22**. That is, two ends of the elastic elements **3** of helical compressible spring are engaged between the post **131** and the fixing block **221** so as to resist against the protection cover **2**. Normally, the protection cover **2** will seal the live wire slot **111**, ground wire slot **112**, and grounding slot **113** (referring to FIGS. 5 and 7). After moving the protection



3

cover **2**, the via holes **21** of the protection cover **2** will align to the live wire slot **111**, ground wire slot **112**, and grounding slot **113** (referring to FIGS. **6** and **9**). Thereby, the security device of a power receptacle of the present invention is formed.

In use of the security device of a power receptacle of the present invention, the protection cover **2** can be elastically resisted by the elastic elements **3** normally so that the live wire slot **111**, ground wire slot **112** and grounding slot **113** are sealed. Thereby, undesired objects can not inserted into wall receptacle **10** or the extension line receptacle **20** with the slot cover **1** and thus dangerous accident can be avoided. Since normally, the protection cover **2** seals the live wire slot **111**, ground wire slot **112** and grounding slot **113**, dusts or insects can not move into the slots. The electric elements of the wall receptacle **10** or the extension line receptacle **20** can be protected so as to increase the lifetime of the wall receptacle **10** and the extension line receptacle **20**.

In the present invention, power can be conducted to a plug inserted in the receptacle (referring to FIG. **8**). The plugs **30** are inserted into the holes **21** of the protection cover **2** and thus moves transversely so that the plugs **30** drive the protection cover **2** to move linearly. When the holes **21** aligns to the live wire slot **111**, ground wire slot **112**, and grounding slot **113**, the plugs **30** can be further inserted into the interior of the live wire slot **111**, ground wire slot **112** and grounding slot **113** (referring to FIG. **9**) to electrically conduct to the electric elements in the wall receptacle **10** or the extension line receptacle **20** having the slot cover **1**. However, when the user pull the plugs **30** out of the receptacle, the protection cover **2** is ejected by the elastic elements **3** to move to the original position to seal the live wire slot **111**, ground wire slot **112**, and grounding slot **113**. Therefore, a safety effect is achieved.

Although the present invention has been described with reference to the preferred embodiments, it will be understood that the invention is not limited to the details described thereof. Various substitutions and modifications have been suggested in the foregoing description, and others will occur to those of ordinary skill in the art. Therefore, all such substitutions and modifications are intended to be embraced within the scope of the invention as defined in the appended claims.

What is claimed is:

1. A security device of a power receptacle comprising:
  - a slot cover being a cover installed on a receptacle;
  - a surface of the slot cover being installed with at least one power slot set;
  - a surface of the power slot set having at least two recesses penetrating to an interior of the receptacle;
  - at least one recess in an inner surface of the slot cover being installed with at least one positioning block at a lateral side thereof;

4

a protection cover configured for isolating contacts of the slot set of the slot cover;

a surface of the protective cover being formed with a plurality of holes, at least one of the holes corresponding to a slot of the slot set;

an inner surface of the protection cover being formed with the plurality of holes of the protective cover and a plurality of hooking arms; the plurality of holes of the protection cover corresponding to the plurality of hooking arms and corresponding to the recesses of the protection cover;

at least one of the hooking arms being installed with the fixing block at a lateral side thereof;

the hooking arms at the inner surface of the protection cover are inserted into the recesses of the slot cover;

the recesses of the slot cover can not be guided to move linearly;

a plurality of elastic elements are installed between each of the positioning blocks of the slot cover and a corresponding one of the fixing blocks of the hooking arms;

the elastic elements resist against the protection cover;

as a result, the protection cover will seal the slot set moreover, after moving the protection cover, the holes of the protection cover will align to the slot set of the slot cover.

2. The security device of a power receptacle as claimed in claim **1**, wherein the receptacle is selected from the group consisting of a wall receptacle and an extension line receptacle.

3. The security device of a power receptacle as claimed in claim **1**, wherein the slots of the slot cover include at least one live wire slot, one ground wire slot and one grounding slot.

4. The security device of a power receptacle as claimed in claim **1**, wherein the slot cover has three recesses; at least two recesses have respective fixing blocks at lateral sides thereof.

5. The security device of a power receptacle as claimed in claim **1**, wherein the positioning block of the slot cover has a U shape and an interior thereof has a post.

6. The security device of a power receptacle as claimed in claim **1**, wherein the positioning block at the lateral side of the hook of the protection cover has a post.

7. The security device of a power receptacle as claimed in claim **1**, wherein the elastic element is a helical compressible spring and two ends of the elastic element are positioned between the positioning block and the fixing block.

\* \* \* \* \*