



US006681403B2

(12) **United States Patent**  
**Lyden**

(10) **Patent No.:** **US 6,681,403 B2**  
(45) **Date of Patent:** **\*Jan. 27, 2004**

(54) **SHIN-GUARD, HELMET, AND ARTICLES OF PROTECTIVE EQUIPMENT INCLUDING LIGHT CURE MATERIAL**

(76) Inventor: **Robert M. Lyden**, 18261 SW. Fallatin Loop, Aloha, OR (US) 97707

(\* ) Notice: Subject to any disclaimer, the term of this patent is extended or adjusted under 35 U.S.C. 154(b) by 0 days.

This patent is subject to a terminal disclaimer.

(21) Appl. No.: **10/213,843**

(22) Filed: **Aug. 7, 2002**

(65) **Prior Publication Data**

US 2002/0188997 A1 Dec. 19, 2002

**Related U.S. Application Data**

(63) Continuation-in-part of application No. 09/523,851, filed on Mar. 13, 2000, now Pat. No. 6,490,730.

(51) **Int. Cl.**<sup>7</sup> ..... **A41D 13/00**

(52) **U.S. Cl.** ..... **2/22; 602/2**

(58) **Field of Search** ..... 2/22, 24, 69, 455, 2/267, 463-467, 2.5, 410-415, 425, 911, 918, DIG. 3; 128/882, DIG. 20; 12/146 M; 36/93; 602/5-8, 20, 23, 41, 60, 62

(56) **References Cited**

**U.S. PATENT DOCUMENTS**

- 2,982,968 A 5/1961 Groot
- 3,613,675 A 10/1971 Larsen
- 3,866,243 A 2/1975 Morgan
- 3,874,376 A 4/1975 Dart et al.
- 3,905,376 A 9/1975 Johnson et al.
- 4,071,424 A 1/1978 Dart et al.
- 4,183,156 A 1/1980 Rudy
- 4,217,705 A 8/1980 Donzis
- 4,219,945 A 9/1980 Rudy
- 4,235,686 A 11/1980 Dart et al.

- 4,271,606 A 6/1981 Rudy
- 4,287,250 A 9/1981 Rudy
- 4,287,613 A 9/1981 Schultz
- 4,292,263 A 9/1981 Hanrahan et al.
- 4,306,315 A 12/1981 Castiglia
- D264,140 S 5/1982 Jenkins
- 4,340,626 A 7/1982 Rudy
- 4,344,189 A 8/1982 Futere et al.
- 4,370,754 A 2/1983 Donzis

(List continued on next page.)

**FOREIGN PATENT DOCUMENTS**

- DE 3011566 A1 11/1980
- DE 4403390 A1 4/1994
- GB 1512553 6/1978
- WO WO 0170061 A2 9/2001 ..... A43B/13/00
- WO WO 0170062 A2 9/2001 ..... A43B/13/00
- WO WO 0170063 A2 9/2001 ..... A43B/13/00
- WO WO 0170064 A2 9/2001 ..... A43B/13/00
- WO WO 0178539 A2 10/2001
- WO WO 0170060 A2 11/2001 ..... A43B/13/18

**OTHER PUBLICATIONS**

Frank H. Netter, M.D., *Atlas of Human Anatomy*, 1989, Plate No. 491.

Abstract, *Neurology*, 1998, Sep.; 51(3): 791-6, "Chronic Traumatic Brain Injury in Professional Soccer Players."

Abstract, *Tidsskr Nor Laegeforen*, 1992, Apr. 10; 112 (10): 1268-71, "Head and Neck Injuries Among Norwegian Soccer Players. A Neurological, Electroencephalographic, Radiologic and Neuropsychological Evaluation."

*Primary Examiner*—Tejash Patel

(74) *Attorney, Agent, or Firm*—Westman, Champlin & Kelly, P.A.

(57) **ABSTRACT**

The present invention teaches novel articles of apparel and protective equipment including light-cure materials having a permanent memory capability. Accordingly, the present invention can be used to make shin-guards, knee pads, thigh pads, hip pads, rib guards, shoulder pads, elbow pads, biceps pads, forearm pads, gloves, neck guards, face guards, chin straps, wrist guards, helmets and prosthetic devices.

**20 Claims, 39 Drawing Sheets**

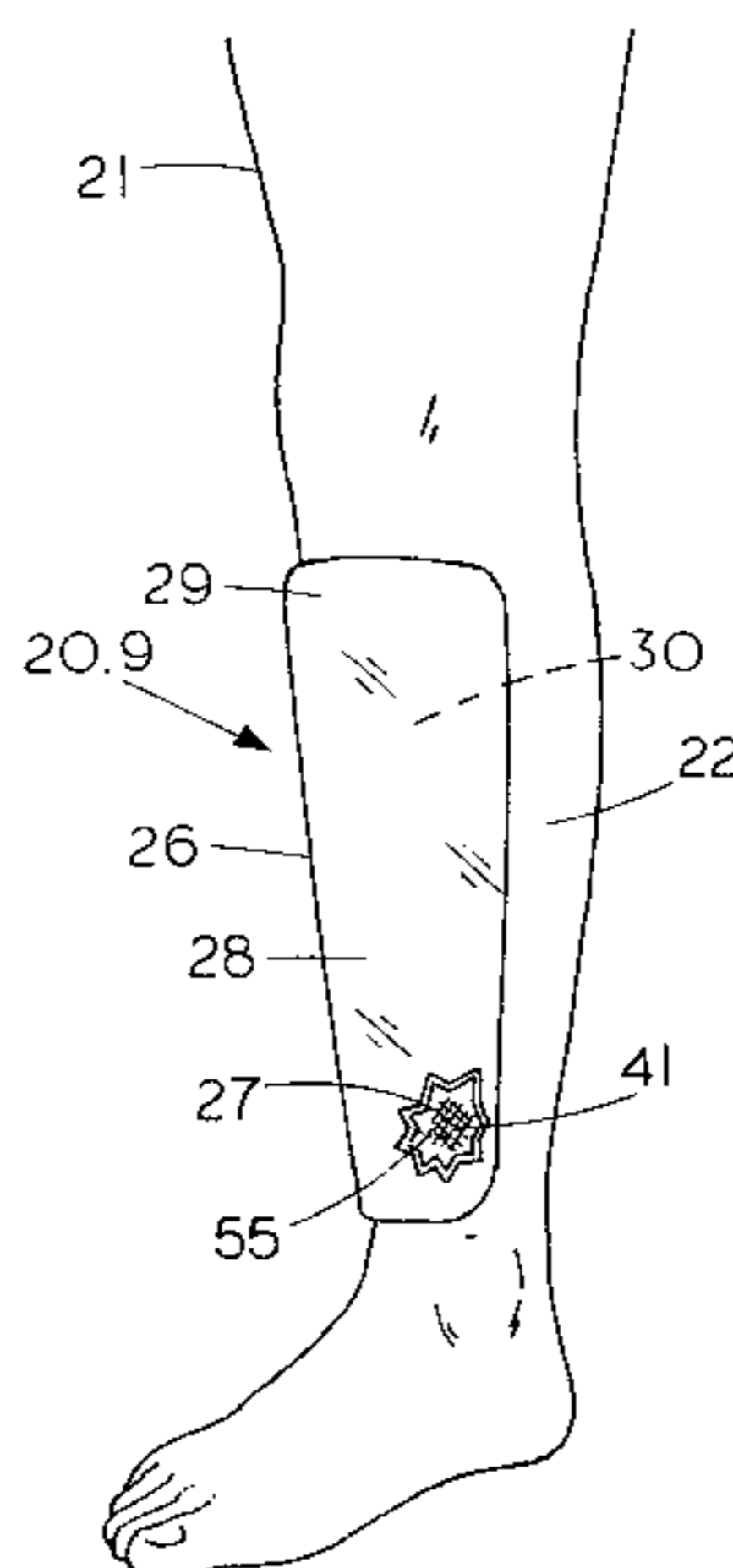

# US 6,681,403 B2

## U.S. PATENT DOCUMENTS

D269,134 S	5/1983	Buring et al.	5,592,706 A	1/1997	Pearce
D269,920 S	8/1983	Buring et al.	D378,624 S	3/1997	Chartrand
4,441,211 A	4/1984	Donzis	5,611,080 A	3/1997	Skottheim
4,453,271 A	6/1984	Donzis	5,625,896 A	5/1997	LaBarbera et al.
4,484,360 A	11/1984	Leighton et al.	5,626,657 A	5/1997	Pearce
4,486,901 A	12/1984	Donzis	5,632,057 A	5/1997	Lyden
D278,470 S	4/1985	Eghamn	5,637,077 A	6/1997	Parker
4,512,340 A	4/1985	Buck	D381,131 S	7/1997	Duback et al.
4,513,449 A	4/1985	Donzis	5,659,900 A	8/1997	Arney et al.
D284,038 S	6/1986	Eghamn et al.	D389,959 S	1/1998	Collins et al.
4,646,368 A	3/1987	Infusino et al.	5,711,028 A	1/1998	Bourque et al.
4,667,661 A	5/1987	Scholtz et al.	5,732,411 A	3/1998	Coleman et al.
4,669,126 A	6/1987	Jones	5,732,713 A	3/1998	Duback et al.
4,674,206 A	6/1987	Lyden	5,742,938 A	4/1998	Winningham et al.
4,683,877 A	8/1987	Ersfeld et al.	5,742,945 A	4/1998	Lindaman
4,756,026 A	7/1988	Pierce, Jr.	D394,110 S	5/1998	Duback et al.
4,774,937 A	10/1988	Scholz et al.	D394,112 S	5/1998	Duback et al.
4,831,668 A	5/1989	Schultz	5,755,001 A	5/1998	Potter et al.
4,856,502 A	8/1989	Ersfeld et al.	5,755,678 A	5/1998	Parker et al.
4,872,216 A	10/1989	Wingo	D394,905 S	6/1998	Duback et al.
4,874,640 A	10/1989	Donzis	D395,158 S	6/1998	Lindaman
4,888,225 A	12/1989	Sandvig et al.	5,766,141 A	6/1998	Gould
4,903,350 A	2/1990	Gentes et al.	5,769,804 A	6/1998	Harris et al.
4,906,502 A	3/1990	Rudy	5,778,449 A	7/1998	Oetting et al.
4,926,501 A	5/1990	Goosen	5,794,272 A	8/1998	Workman et al.
4,926,503 A	5/1990	Wingo	5,794,274 A	8/1998	Kraemer
4,936,029 A	6/1990	Rudy	5,802,739 A	9/1998	Potter et al.
D310,278 S	8/1990	Quinlan	5,813,050 A	9/1998	Popowski
4,946,726 A	8/1990	Sandvig et al.	5,829,055 A	11/1998	Collins et al.
D311,977 S	11/1990	Eghamn	5,832,630 A	11/1998	Potter
4,970,807 A	11/1990	Anderie et al.	5,842,475 A	12/1998	Duback et al.
4,985,931 A	1/1991	Wingo	5,868,693 A	2/1999	Duback et al.
4,993,082 A	2/1991	Gentes et al.	5,890,224 A	4/1999	Clark
4,999,847 A	3/1991	Barcelo	5,911,310 A	6/1999	Bridgers
5,002,047 A	3/1991	Sandvig et al.	5,926,844 A	7/1999	Bear
5,014,689 A	5/1991	Meunchen et al.	5,952,078 A	9/1999	Park
5,029,341 A	7/1991	Wingo	5,976,451 A	11/1999	Skaja et al.
5,035,009 A	7/1991	Wingo	5,979,078 A	11/1999	McLaughlin
5,036,761 A	8/1991	Wingo	5,993,585 A	11/1999	Goodwin et al.
5,040,795 A	8/1991	Sonntag	6,013,340 A	1/2000	Bonk et al.
5,042,176 A	8/1991	Rudy	6,020,055 A	2/2000	Pearce
5,042,464 A	8/1991	Skwor et al.	6,029,962 A	2/2000	Shorten et al.
5,083,361 A	1/1992	Rudy	6,065,152 A	5/2000	Parker
5,101,580 A	4/1992	Lyden	6,082,025 A	7/2000	Bonk et al.
5,118,722 A	6/1992	Wollmann et al.	6,098,313 A	8/2000	Skaja
5,175,889 A	1/1993	Infusino	6,105,164 A	8/2000	Huang
5,181,717 A	1/1993	Donntag et al.	6,119,371 A	9/2000	Goodwin et al.
5,190,802 A	3/1993	Pilato	6,126,626 A	10/2000	Duback et al.
5,203,793 A	4/1993	Lyden	6,127,026 A	10/2000	Bonk et al.
5,235,715 A	8/1993	Donzis	6,128,777 A	10/2000	Foreman
5,263,203 A	11/1993	Kraemer et al.	6,131,195 A	10/2000	Foreman
5,297,294 A	3/1994	Washick	6,134,720 A	10/2000	Foreman
5,301,370 A	4/1994	Henson	6,152,892 A	11/2000	Masini
5,378,531 A	1/1995	Larson et al.	6,161,240 A	12/2000	Huang
5,381,560 A	1/1995	Halstead	6,178,556 B1	1/2001	Foreman et al.
5,384,913 A	1/1995	Hendry	6,202,223 B1	3/2001	Chartrand
5,405,312 A	4/1995	Jacobs	6,205,583 B1	3/2001	Beland
5,406,719 A	4/1995	Potter	6,226,795 B1	5/2001	Winningham
5,435,007 A	7/1995	Kalvestran et al.	6,226,797 B1	5/2001	Tollini
5,437,112 A	8/1995	Johnston	6,247,188 B1	6/2001	Beland
D362,087 S	9/1995	Anson	D445,221 S	7/2001	Foreman et al.
5,454,780 A	10/1995	Duback et al.	6,258,421 B1	7/2001	Potter
5,456,658 A	10/1995	Duback et al.	6,269,485 B1	8/2001	Foreman
5,477,559 A	12/1995	Clement	6,298,484 B1	10/2001	Beckman
5,480,376 A	1/1996	Duback et al.	6,321,465 B1	11/2001	Bonk et al.
5,481,762 A	1/1996	Gentes et al.	6,374,514 B1	4/2002	Swigart
5,491,840 A	2/1996	Yen	6,385,864 B1	5/2002	Sell, Jr. et al.
5,543,194 A	8/1996	Rudy	6,391,405 B1	5/2002	Bonk et al.
5,544,663 A	8/1996	Duback	6,402,879 B1	6/2002	Tawney et al.
5,572,804 A	11/1996	Skaja et al.	6,430,843 B1	8/2002	Potter et al.
5,575,017 A	11/1996	Hefling et al.	6,457,262 B1	10/2002	Swigart
5,581,817 A	12/1996	Hicks	6,490,730 B1 *	12/2002	Lyden ..... 2/22

\* cited by examiner

FIG. 1

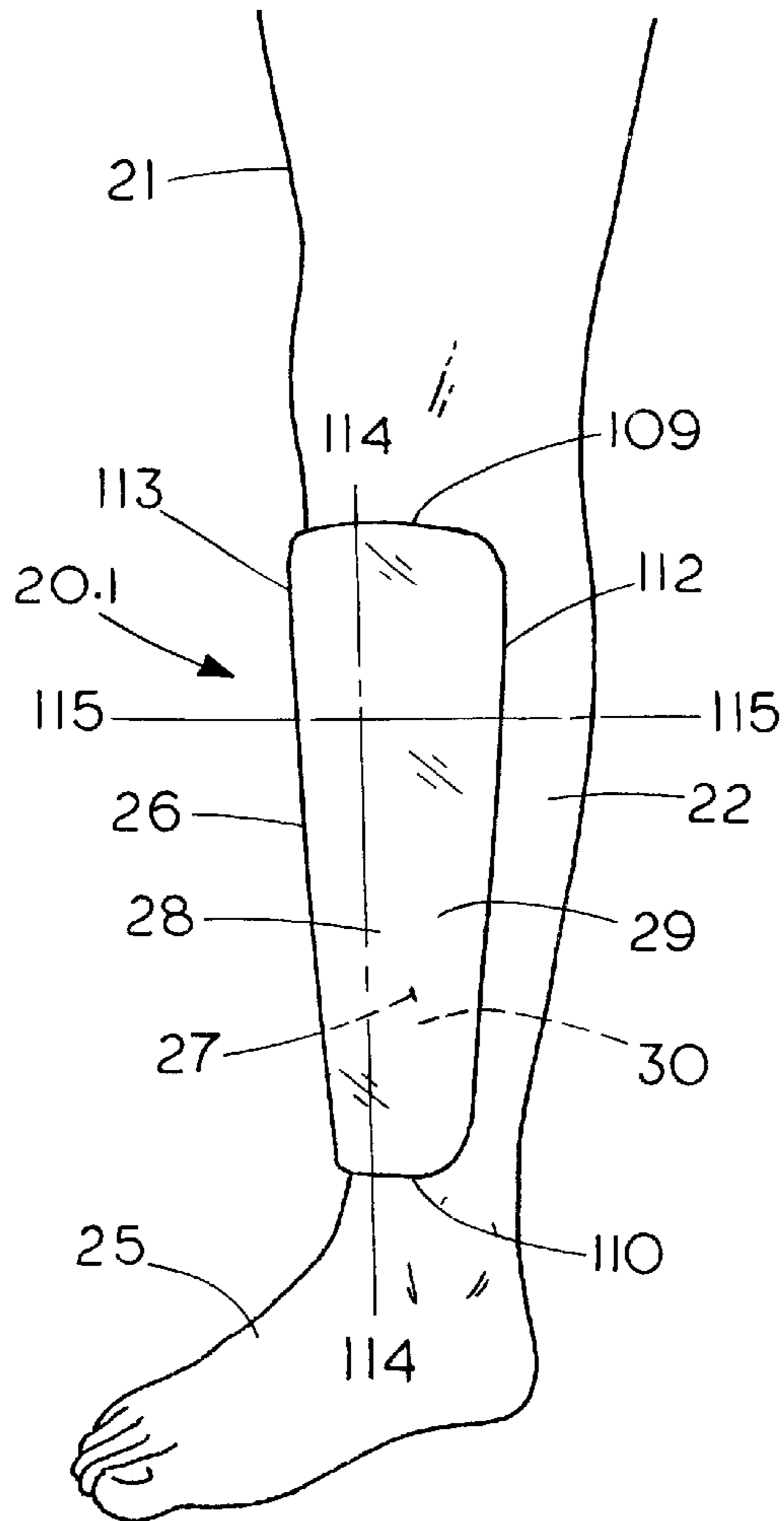

FIG. 2

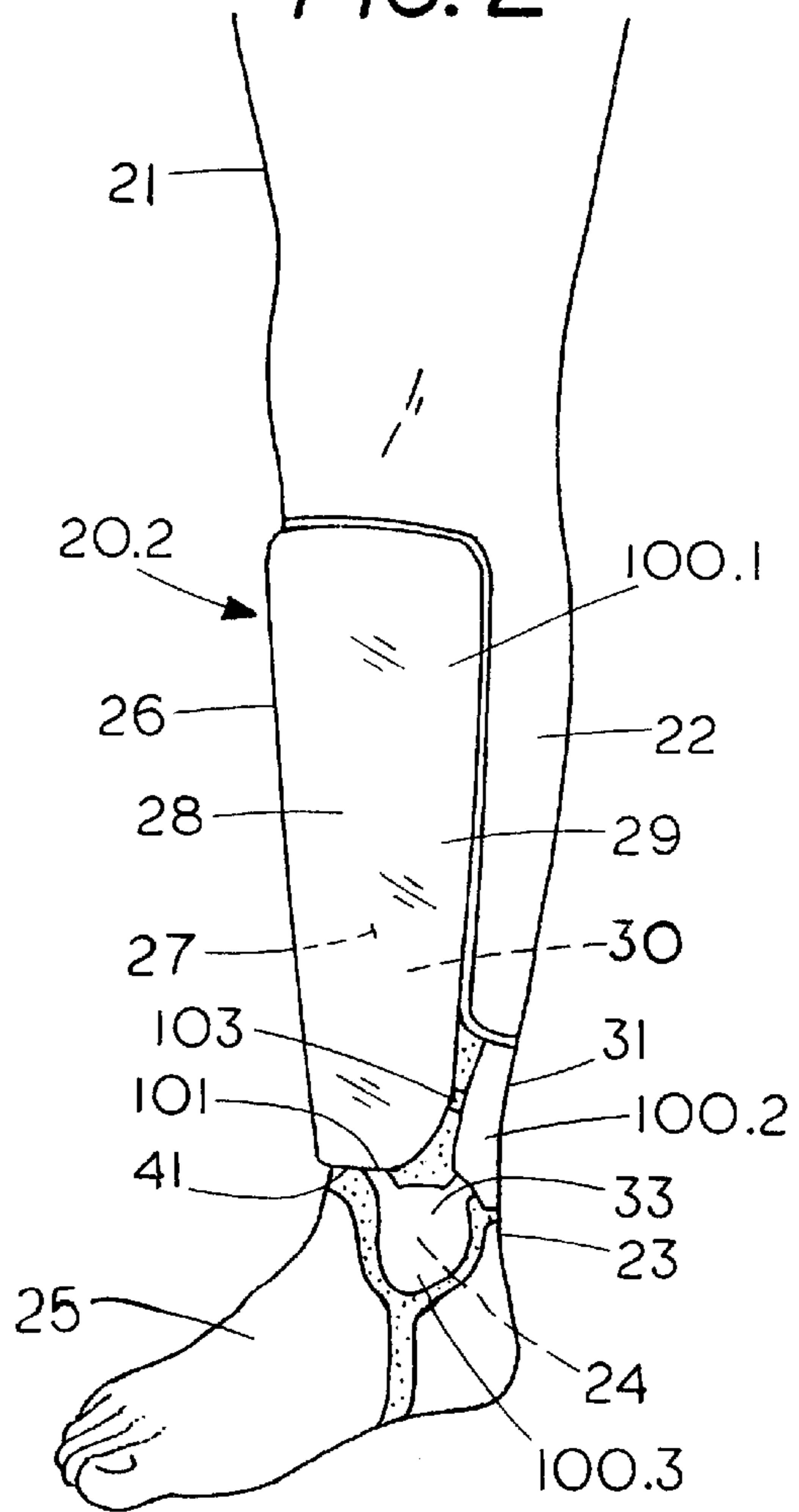

FIG. 3

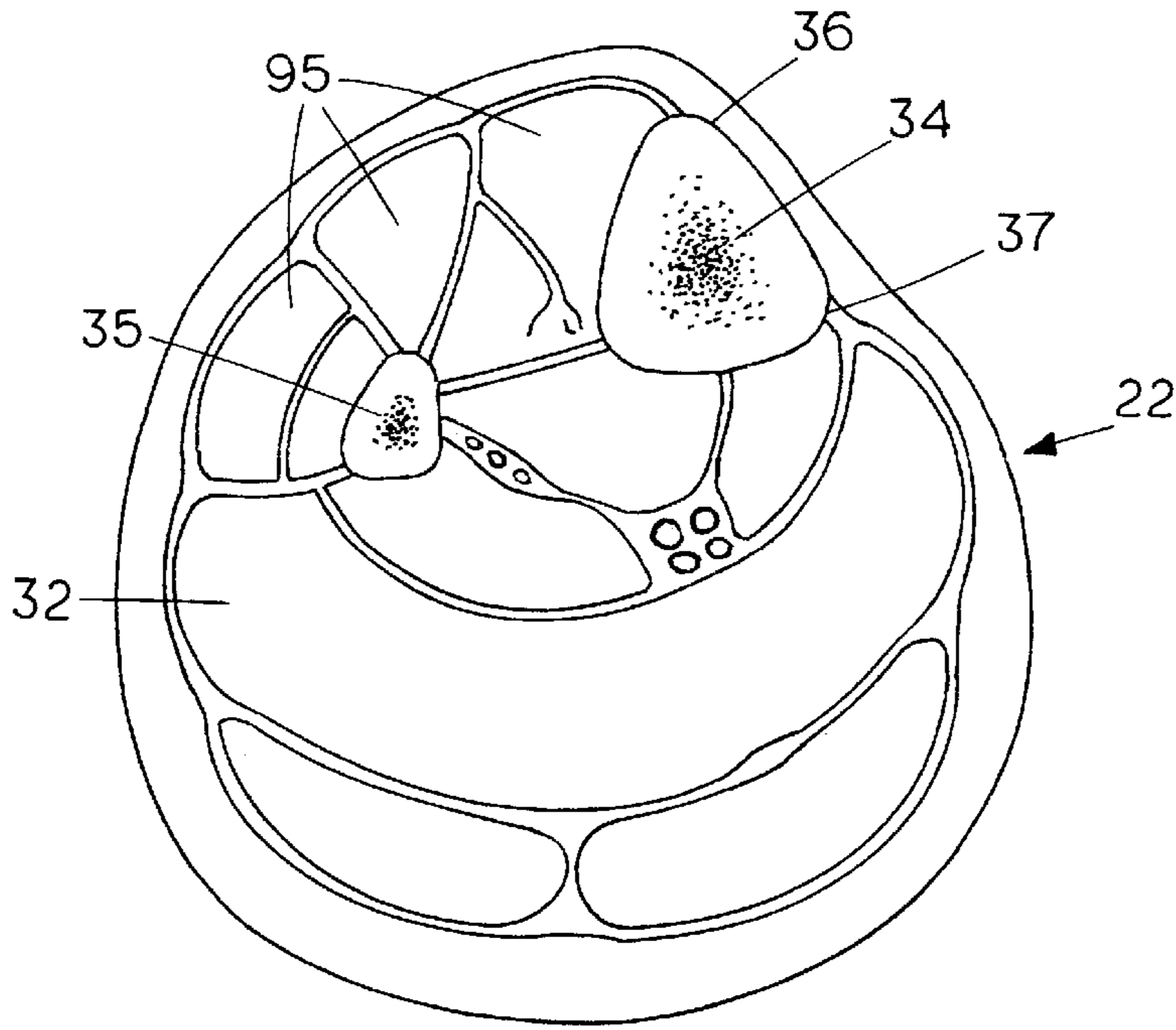

FIG. 4

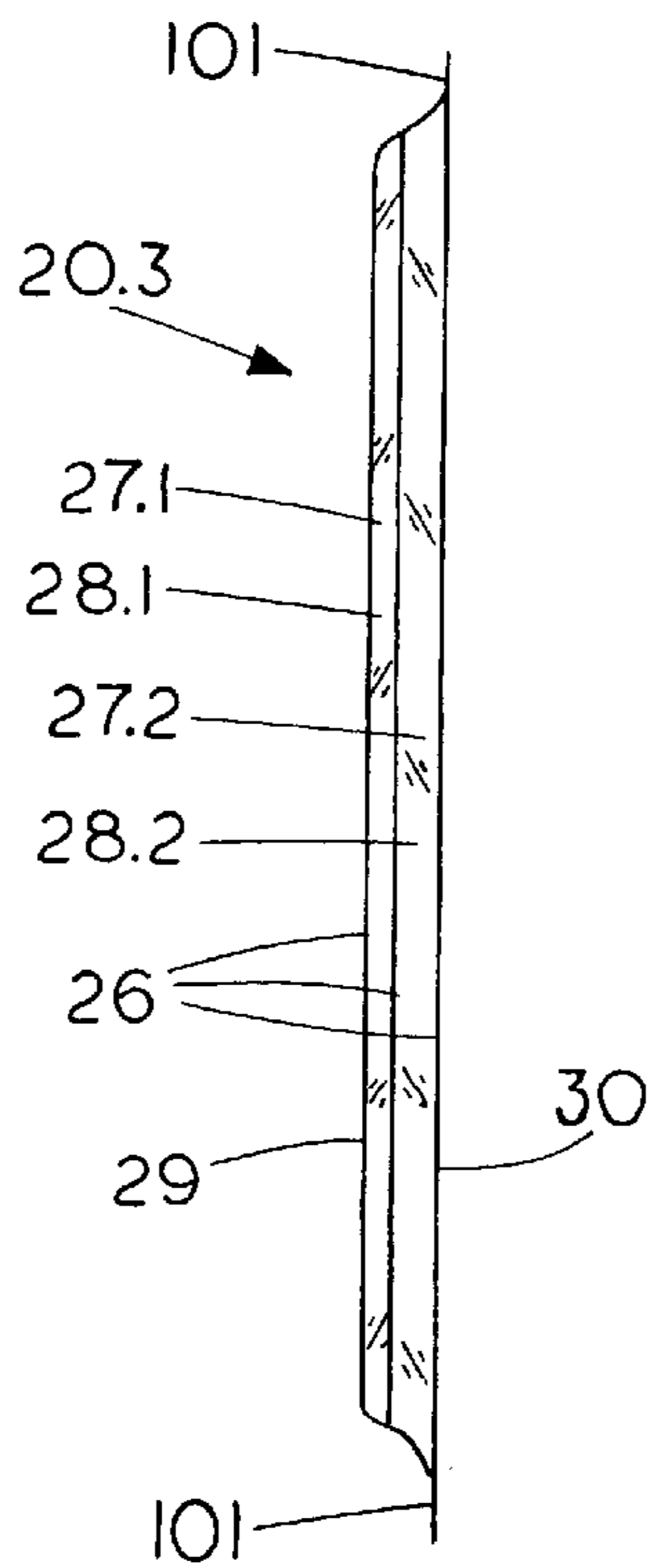

FIG. 5

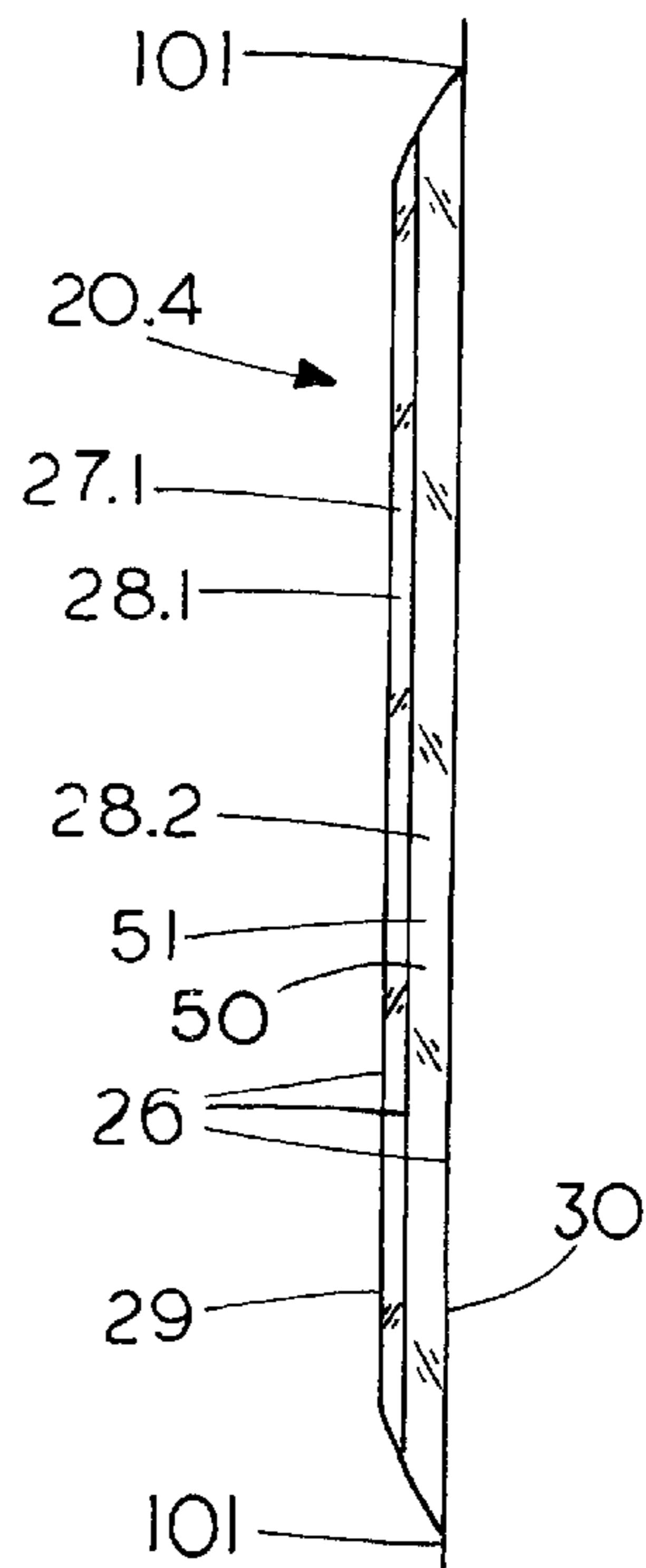

FIG. 6

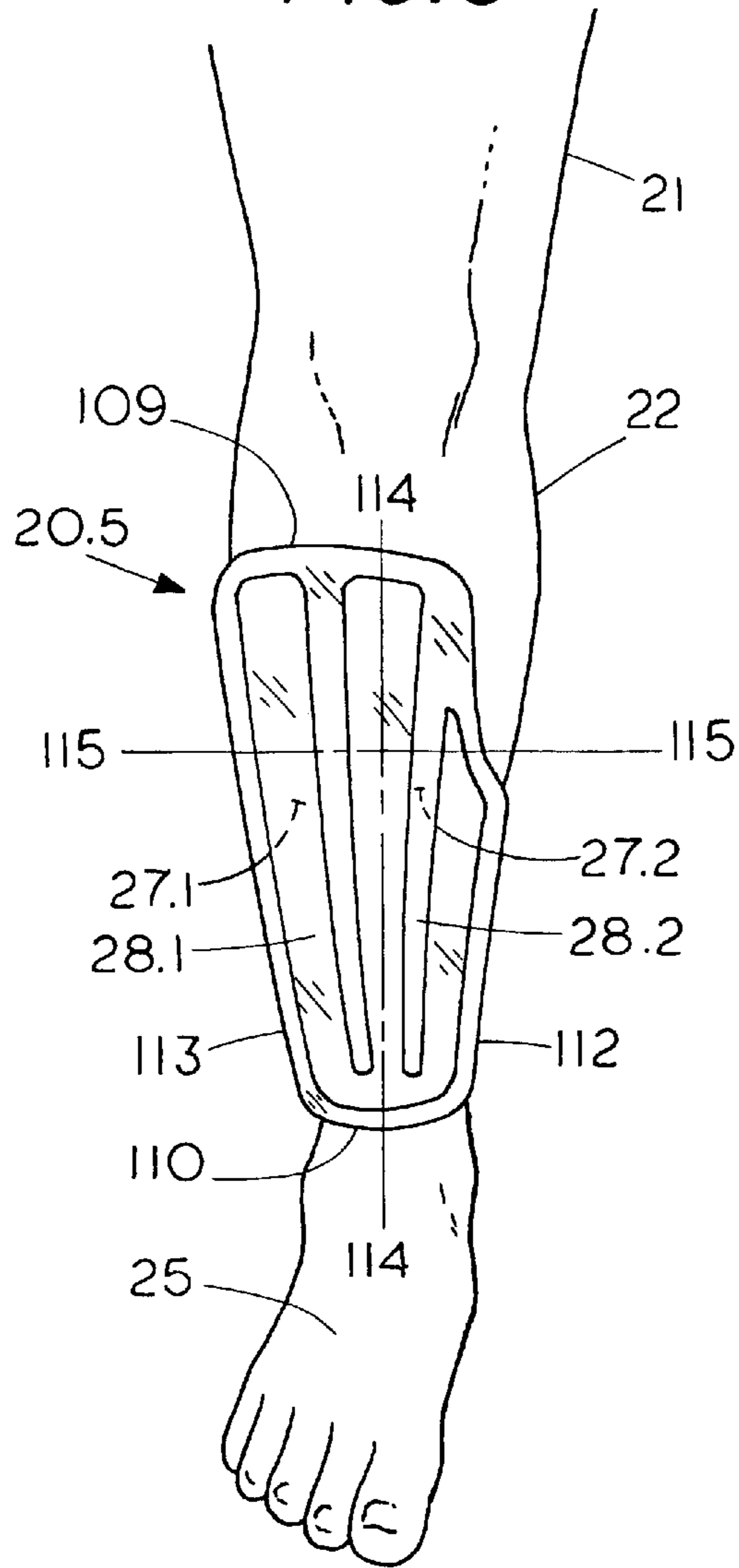

FIG. 7

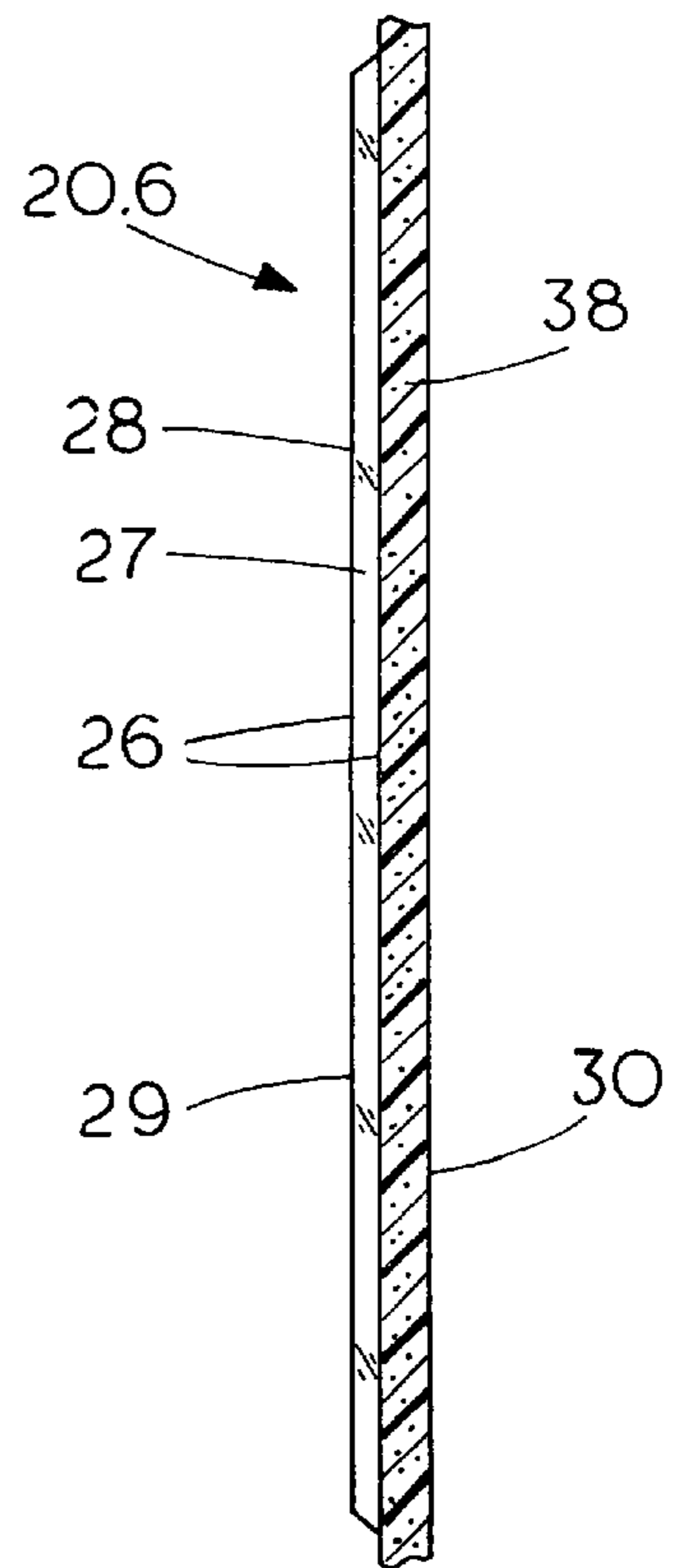

FIG. 8

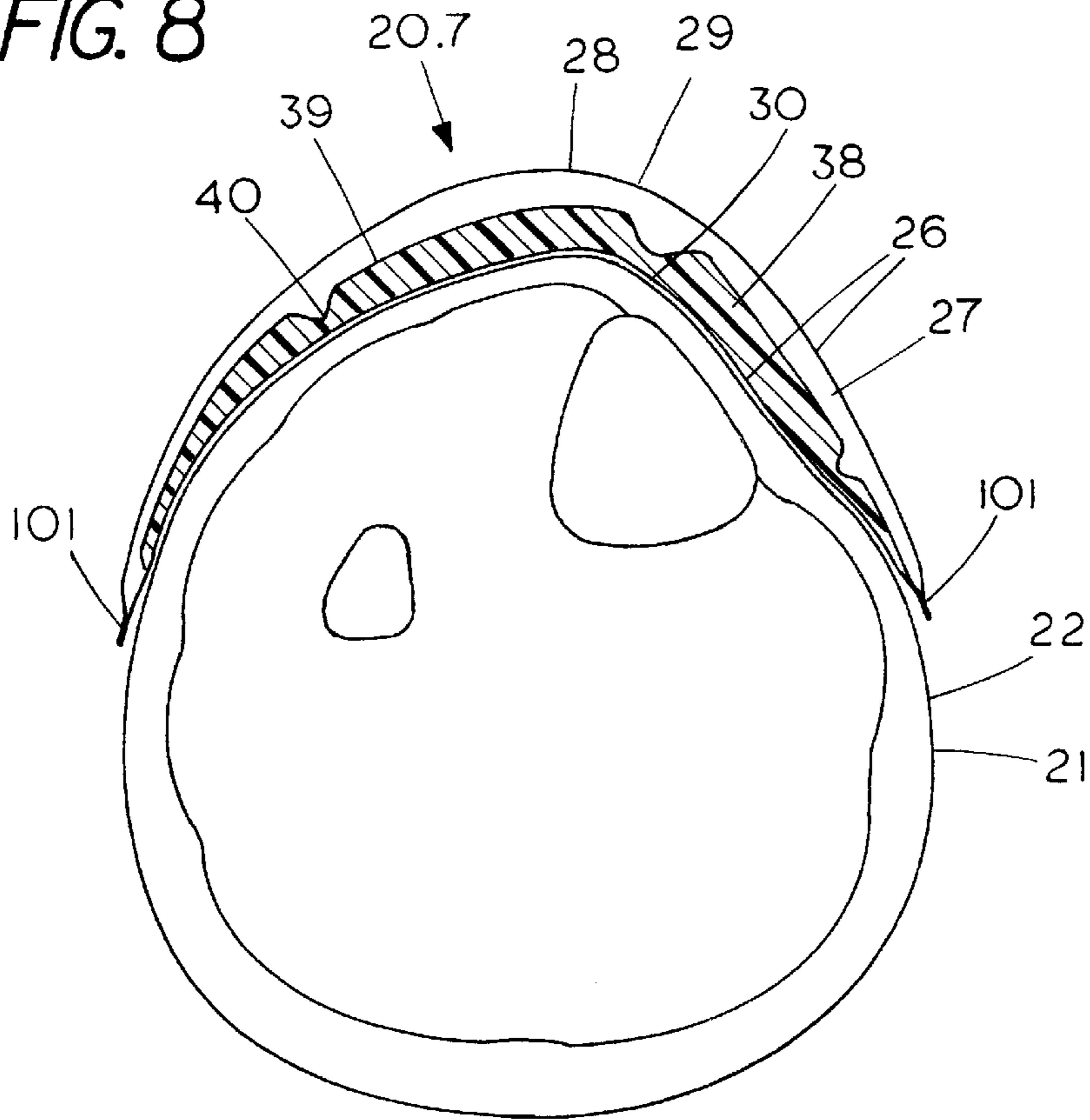

FIG. 9

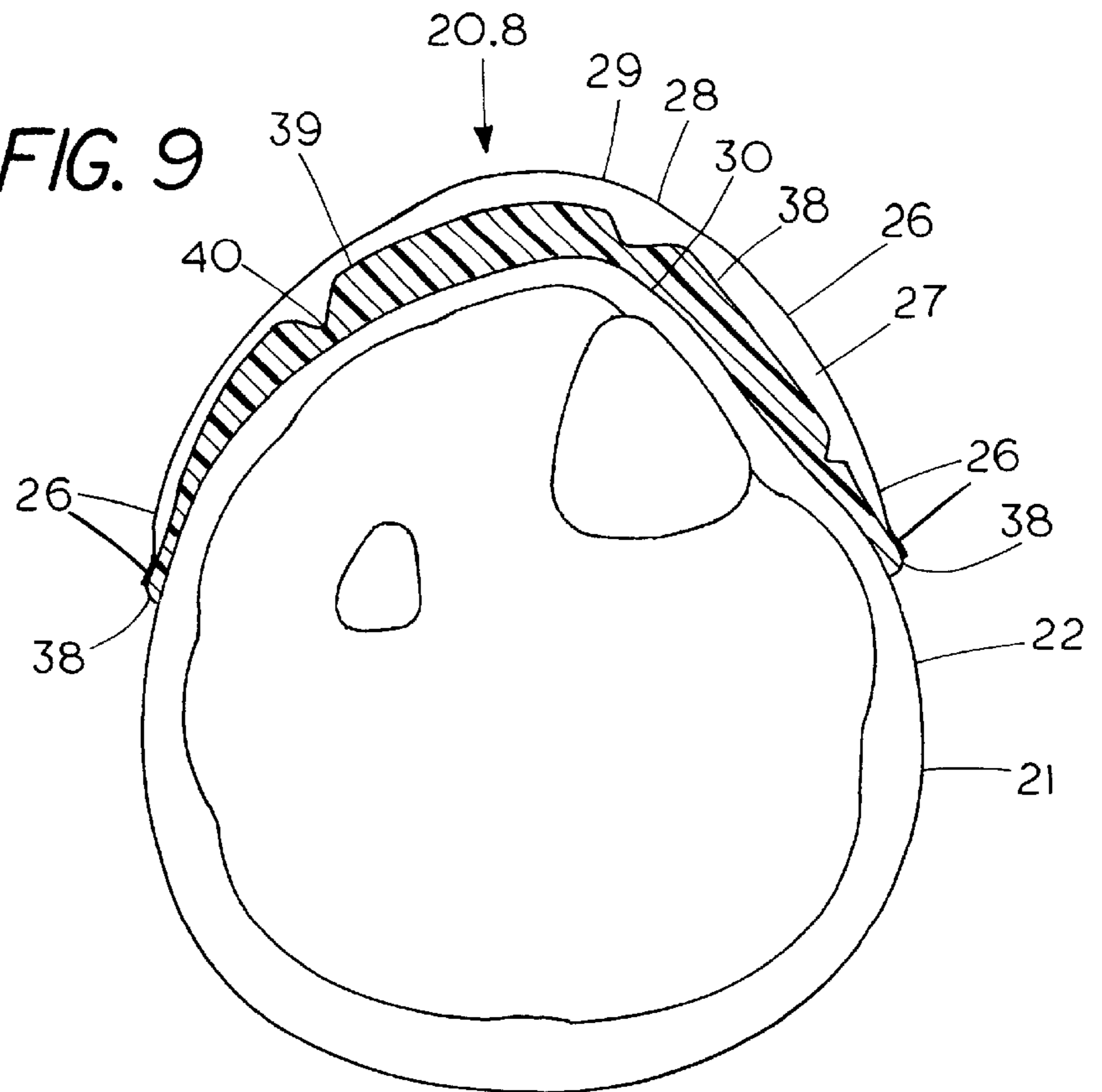

FIG. 11

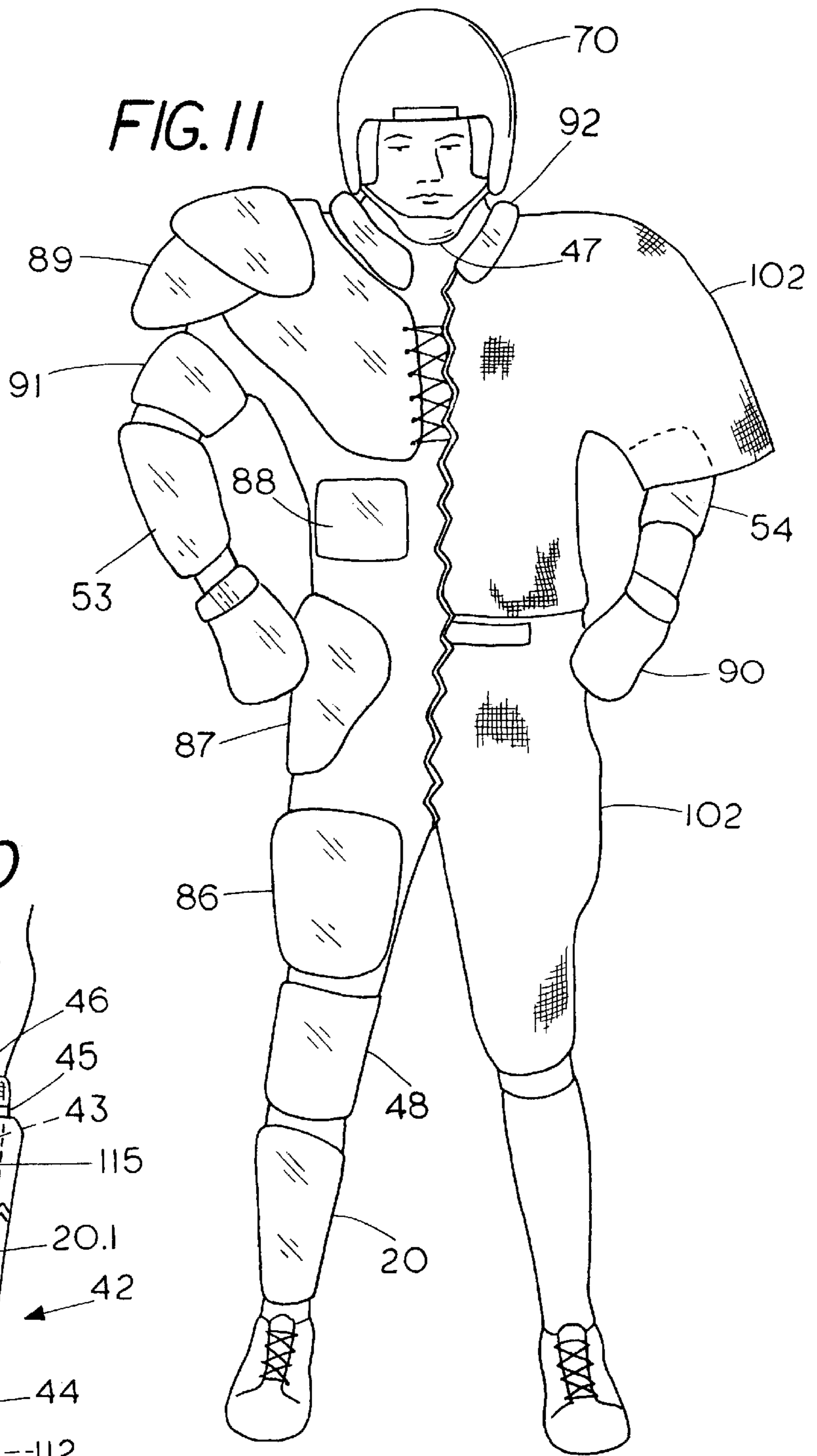

FIG. 10

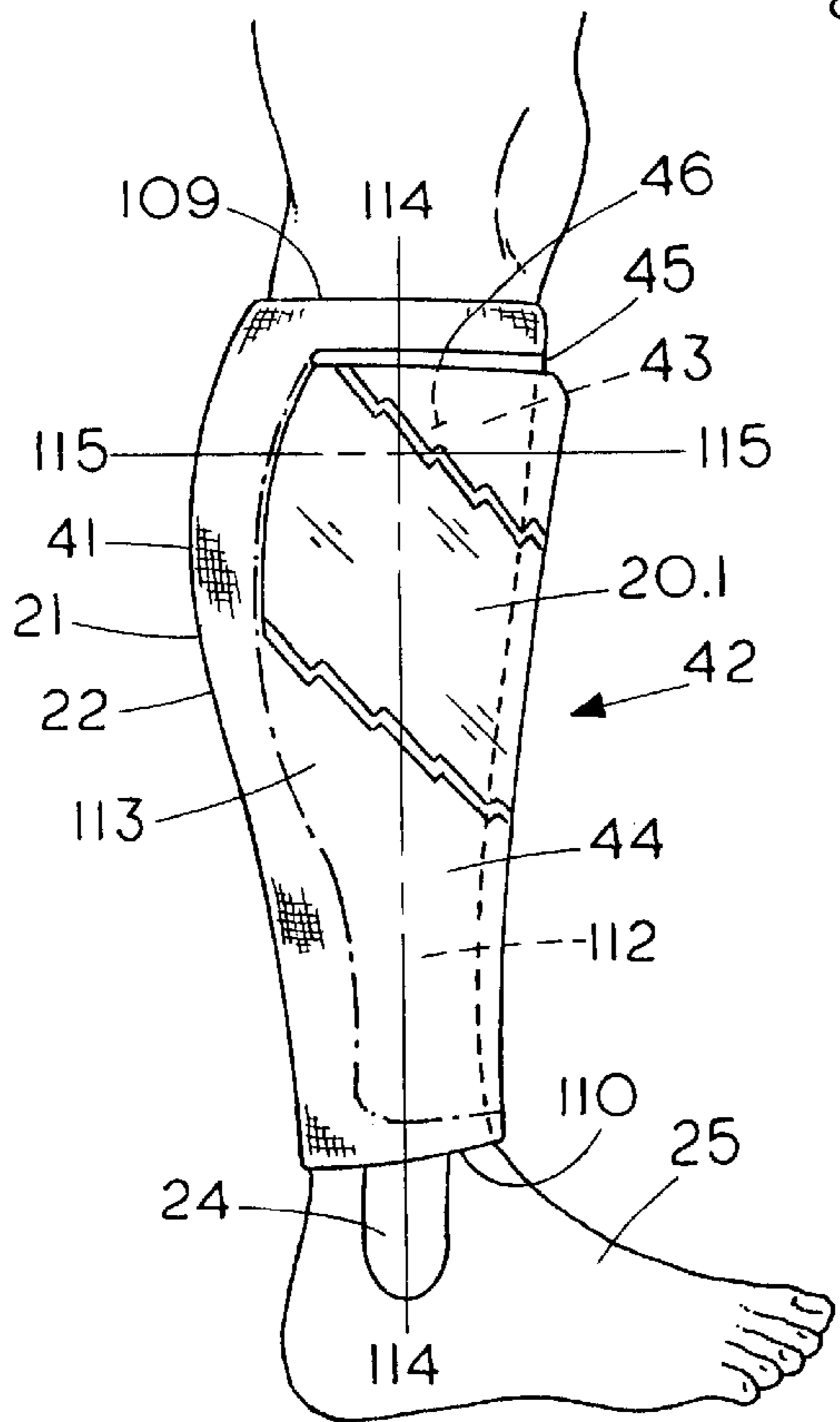

FIG. 12

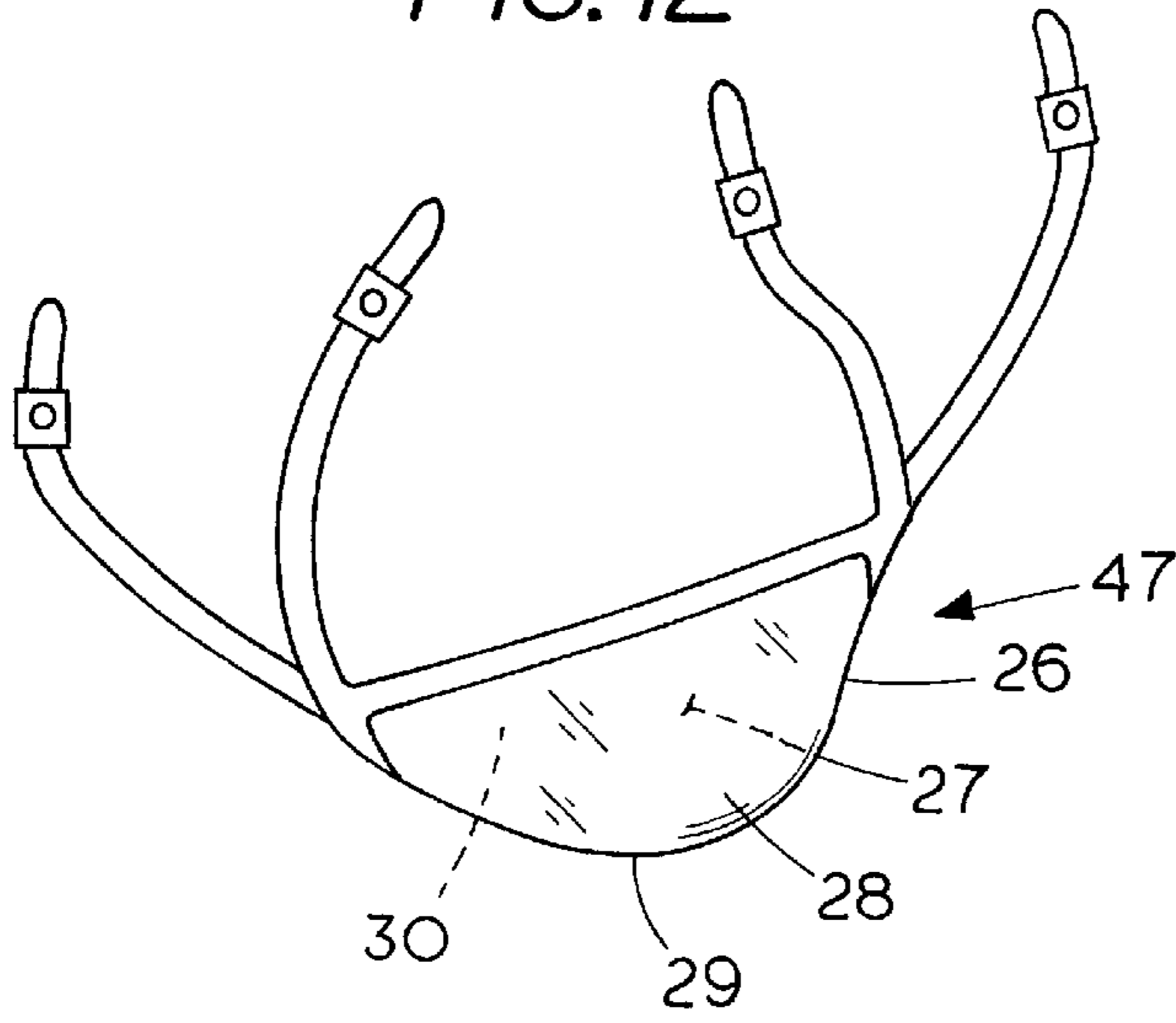

FIG. 13

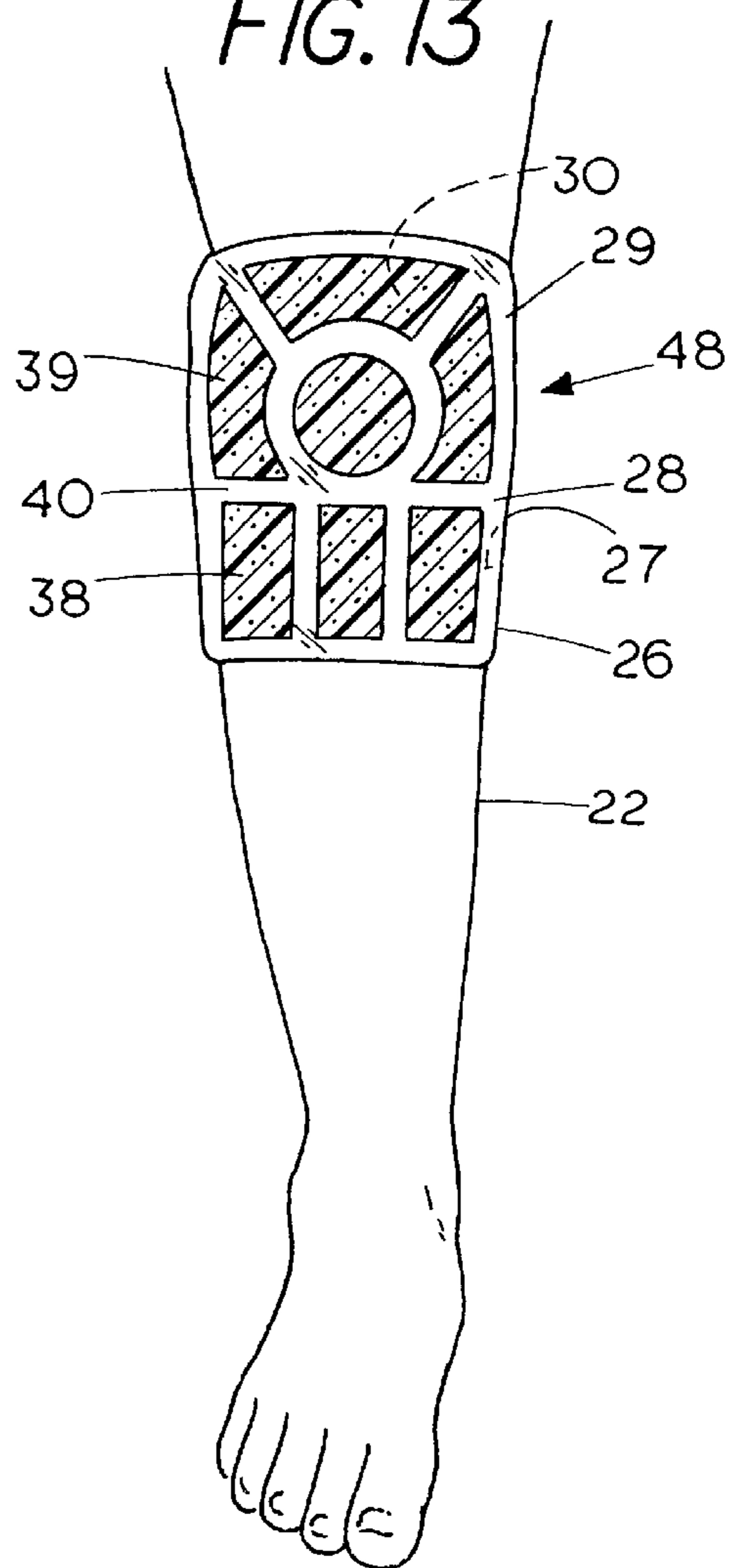

FIG. 14

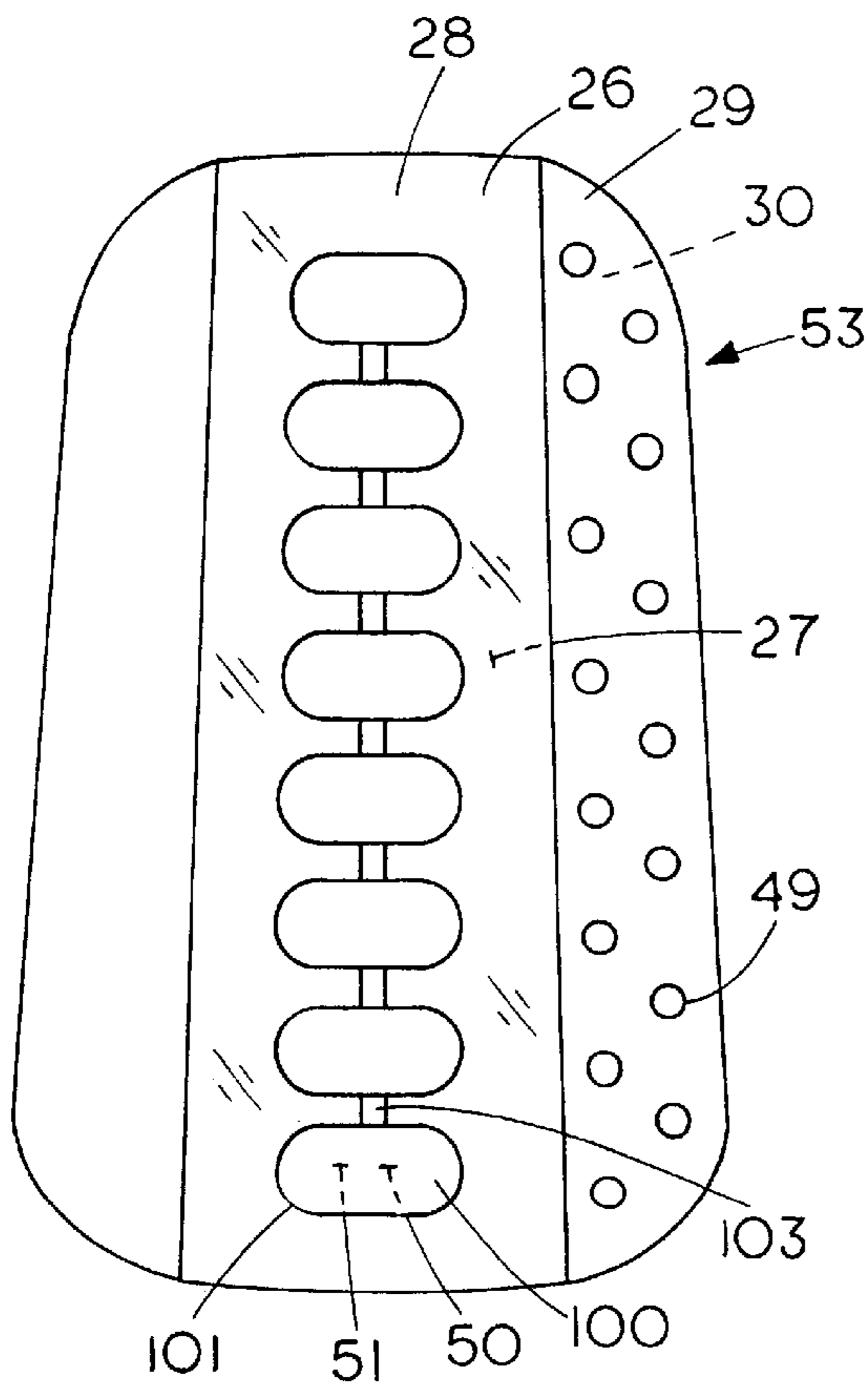



FIG. 15

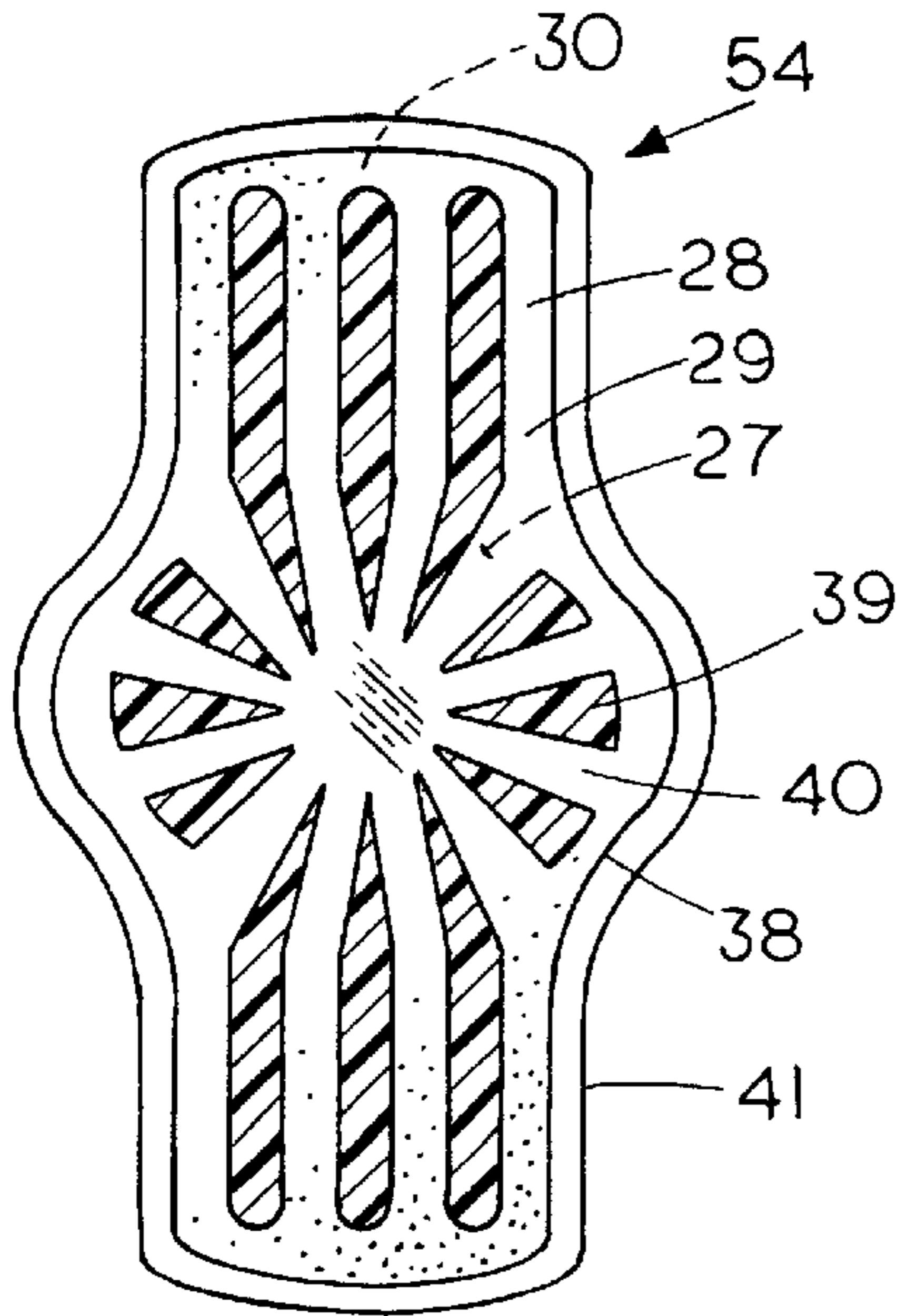

FIG. 16.1

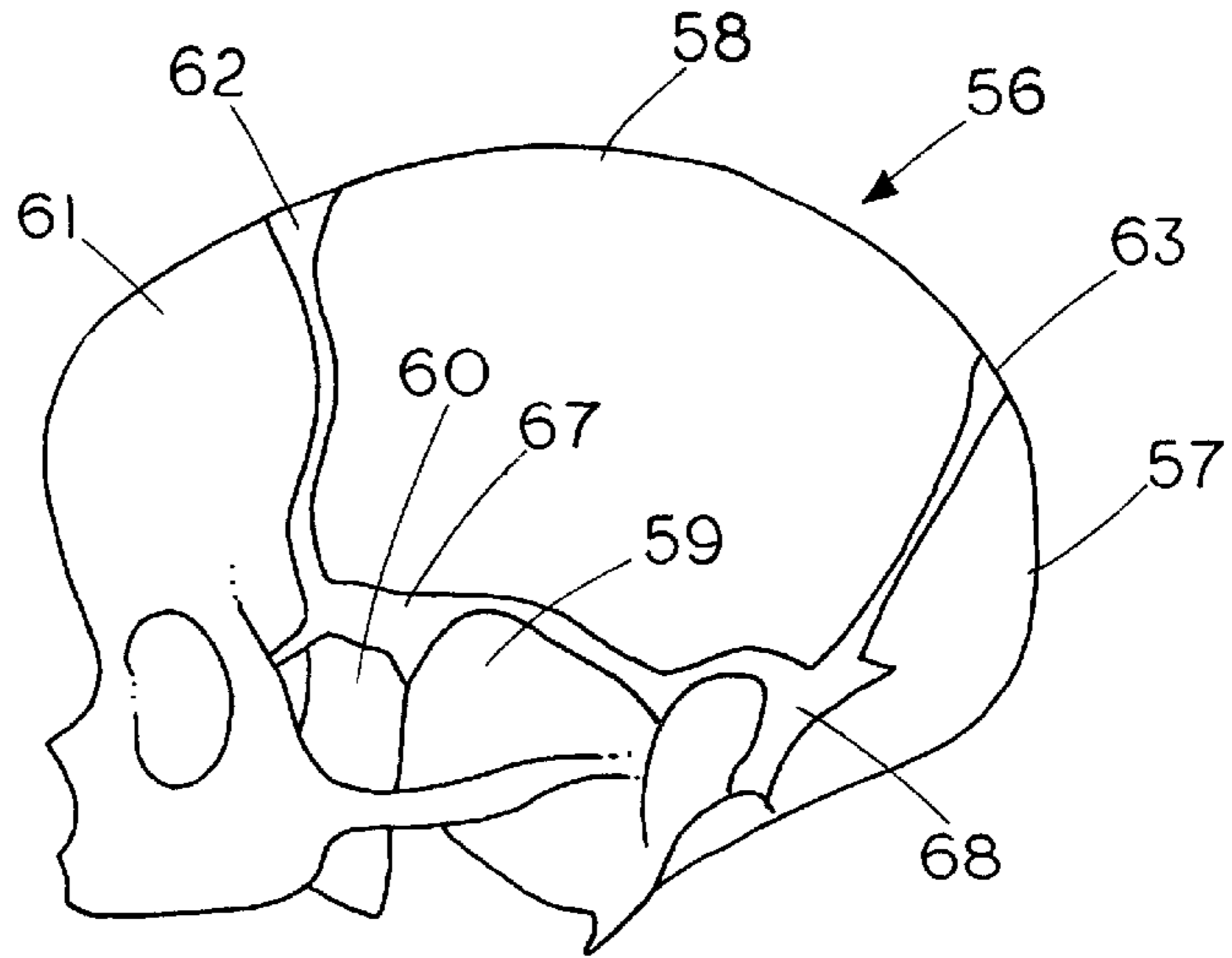

FIG. 16.2

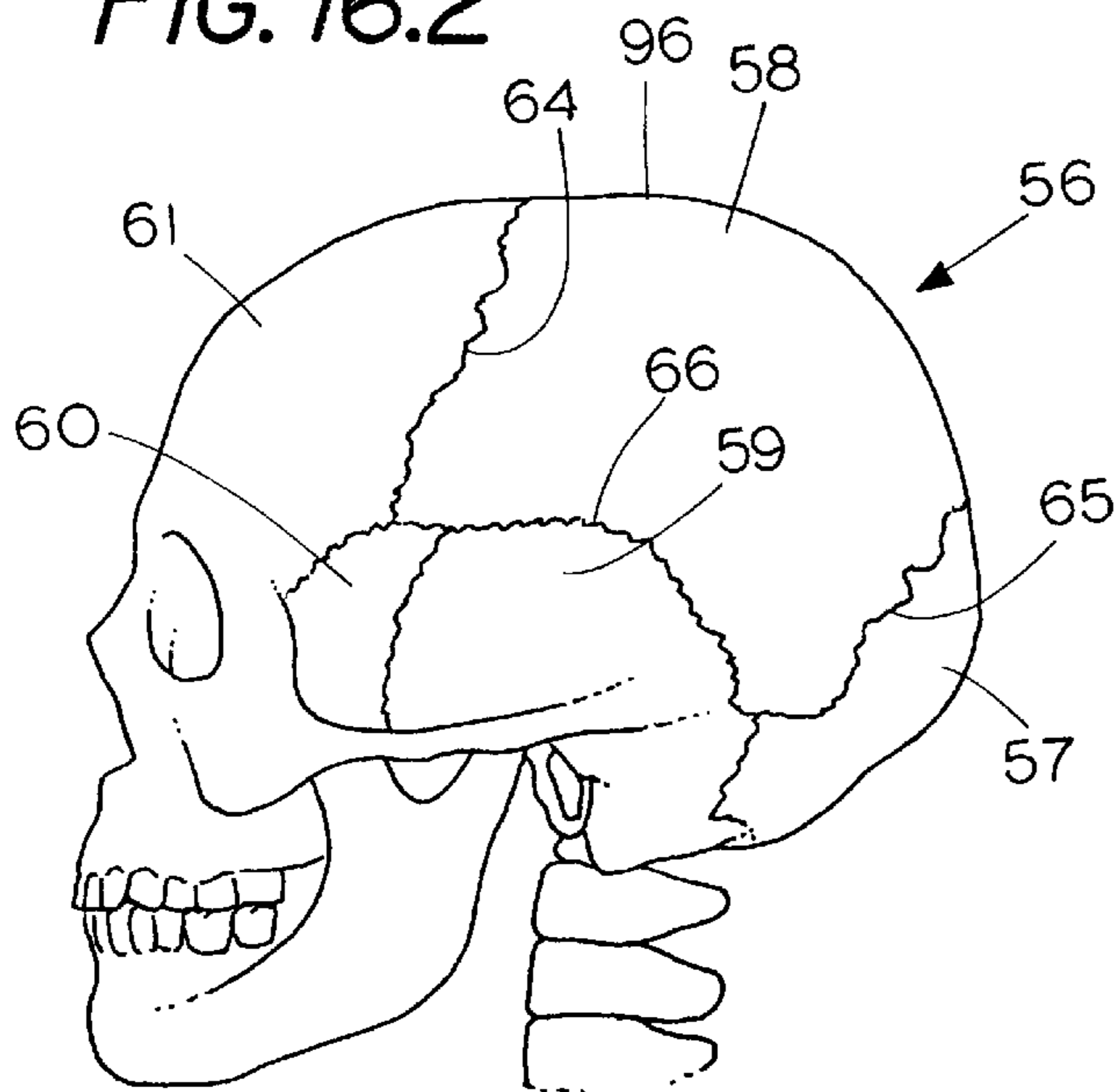

FIG. 17

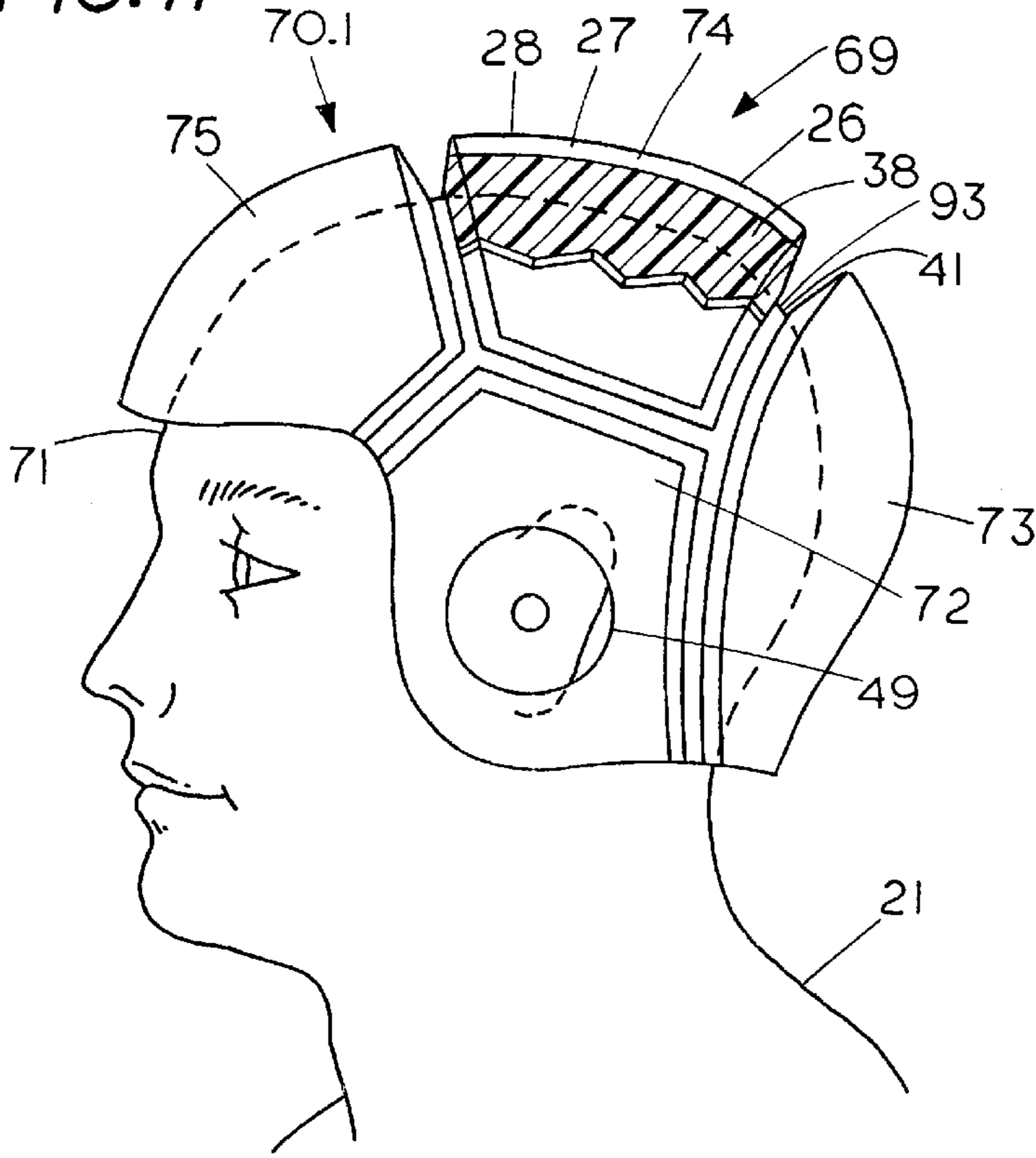

FIG. 18

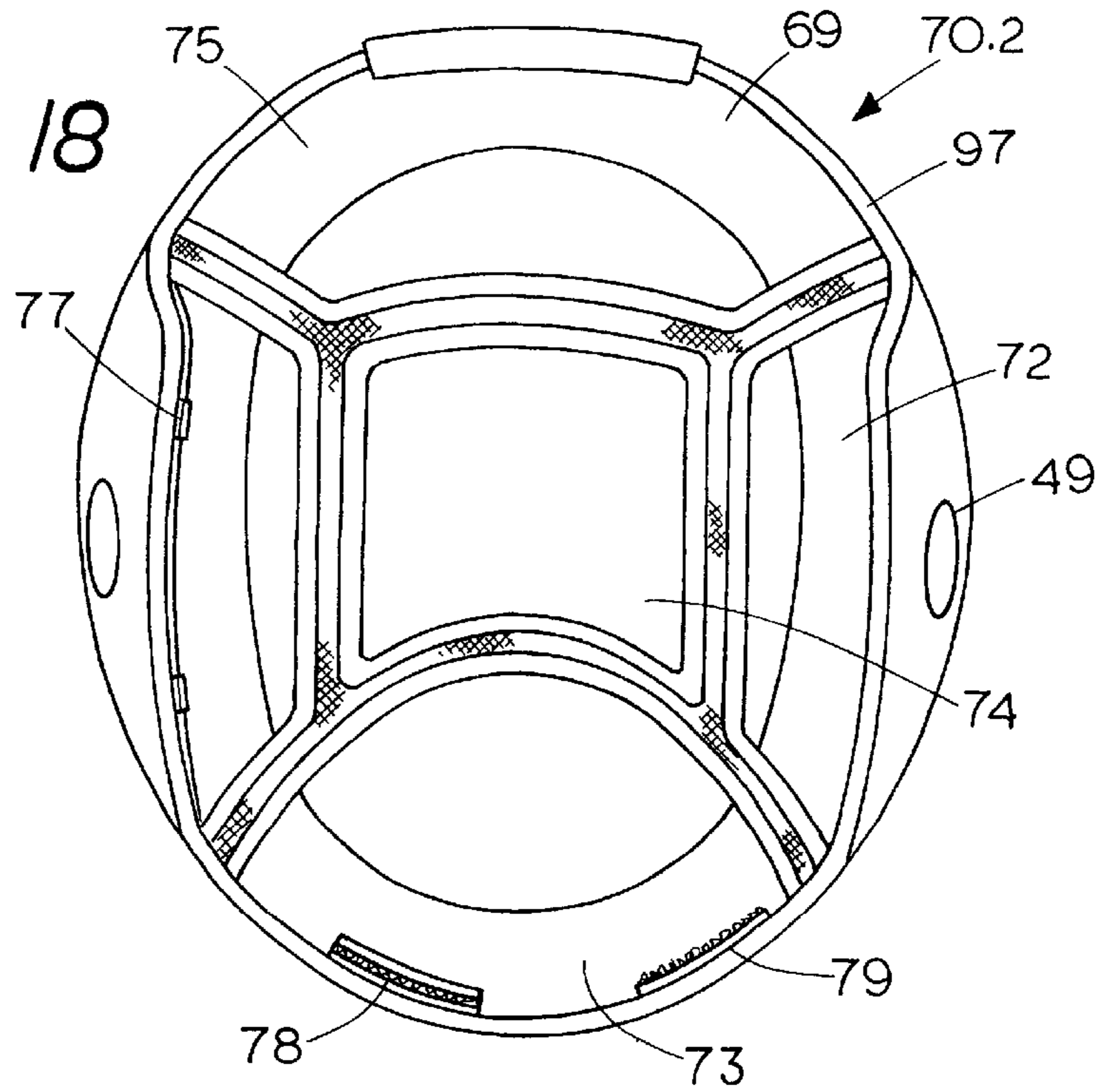

FIG. 19

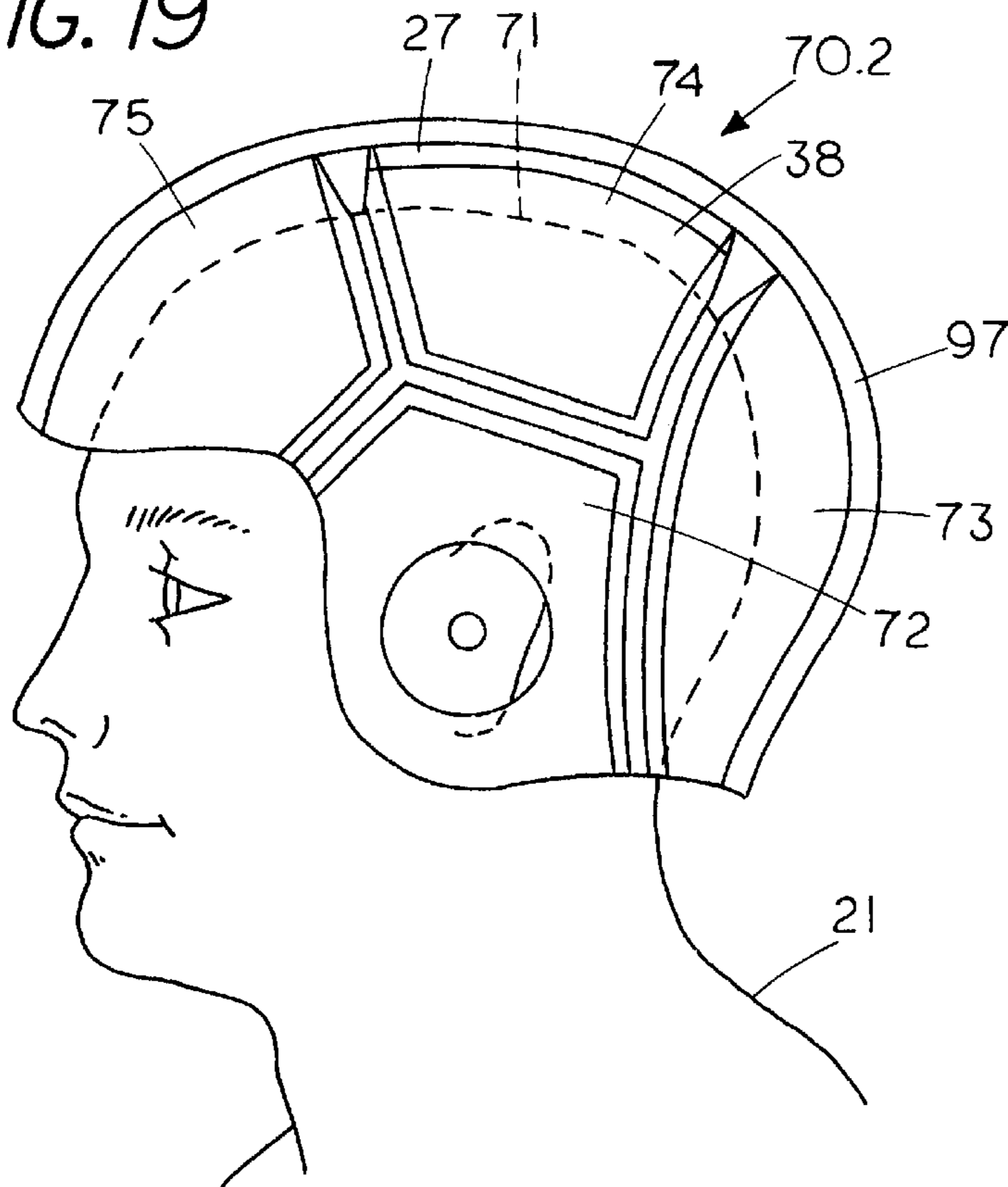
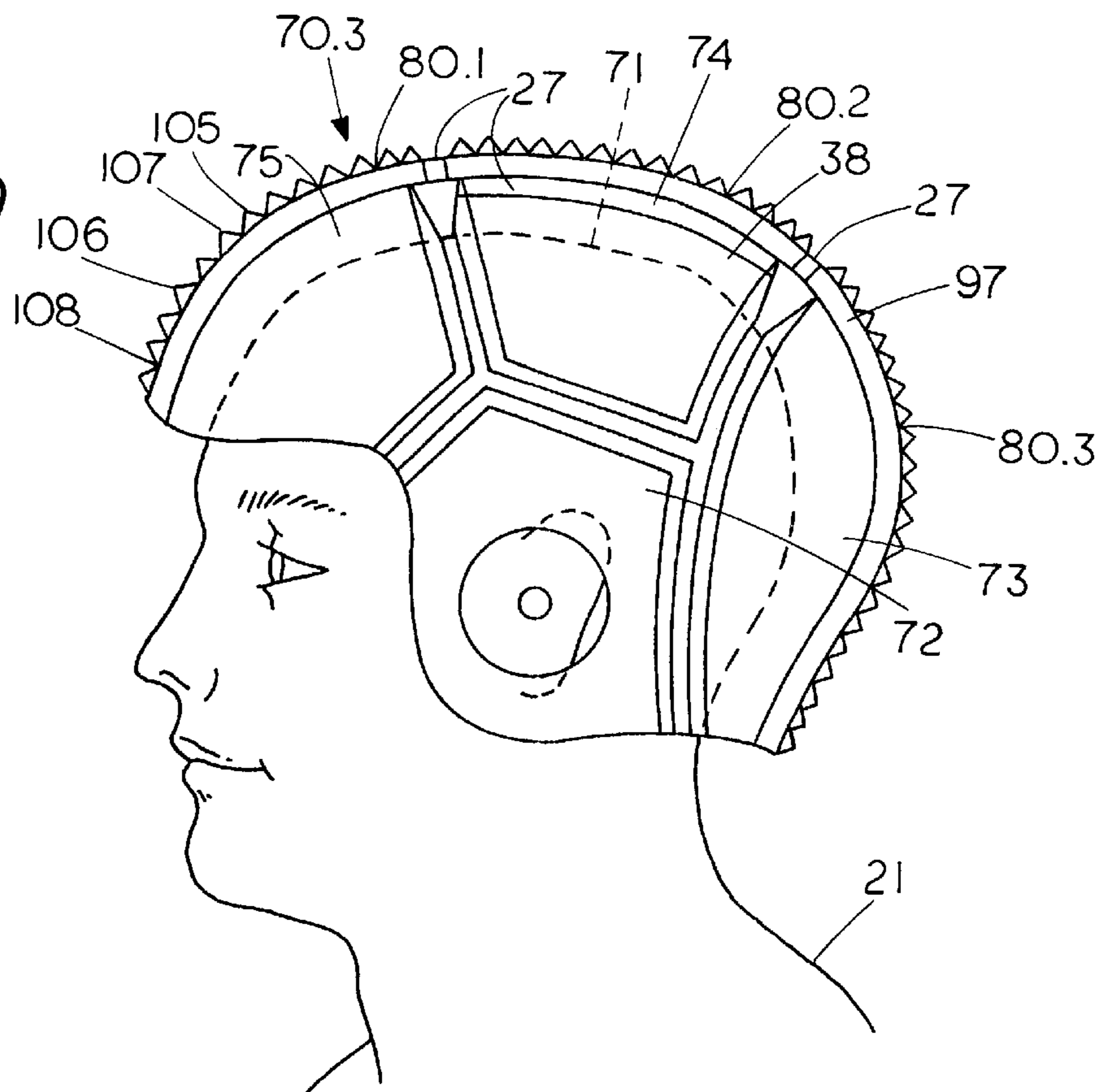

FIG. 20



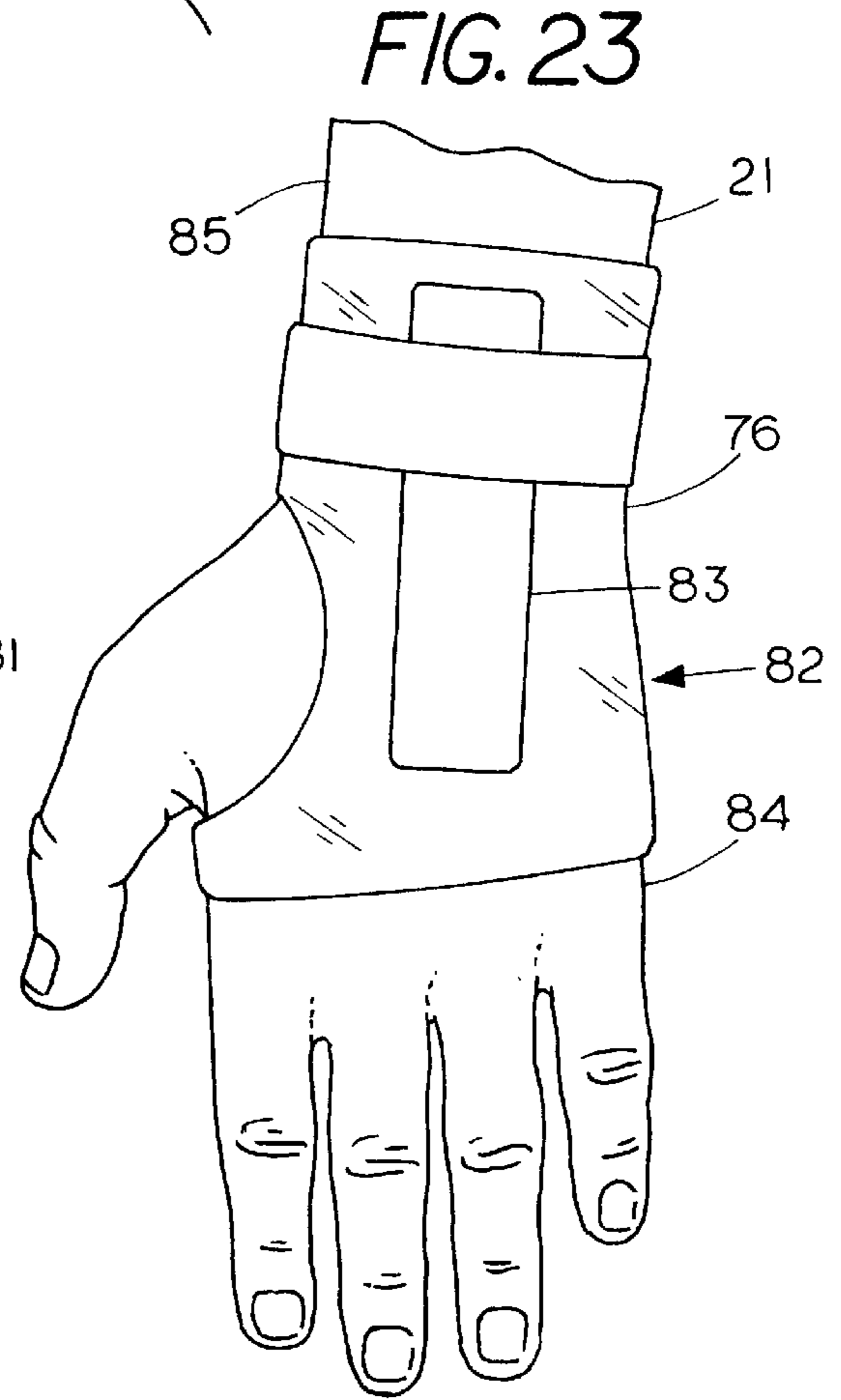
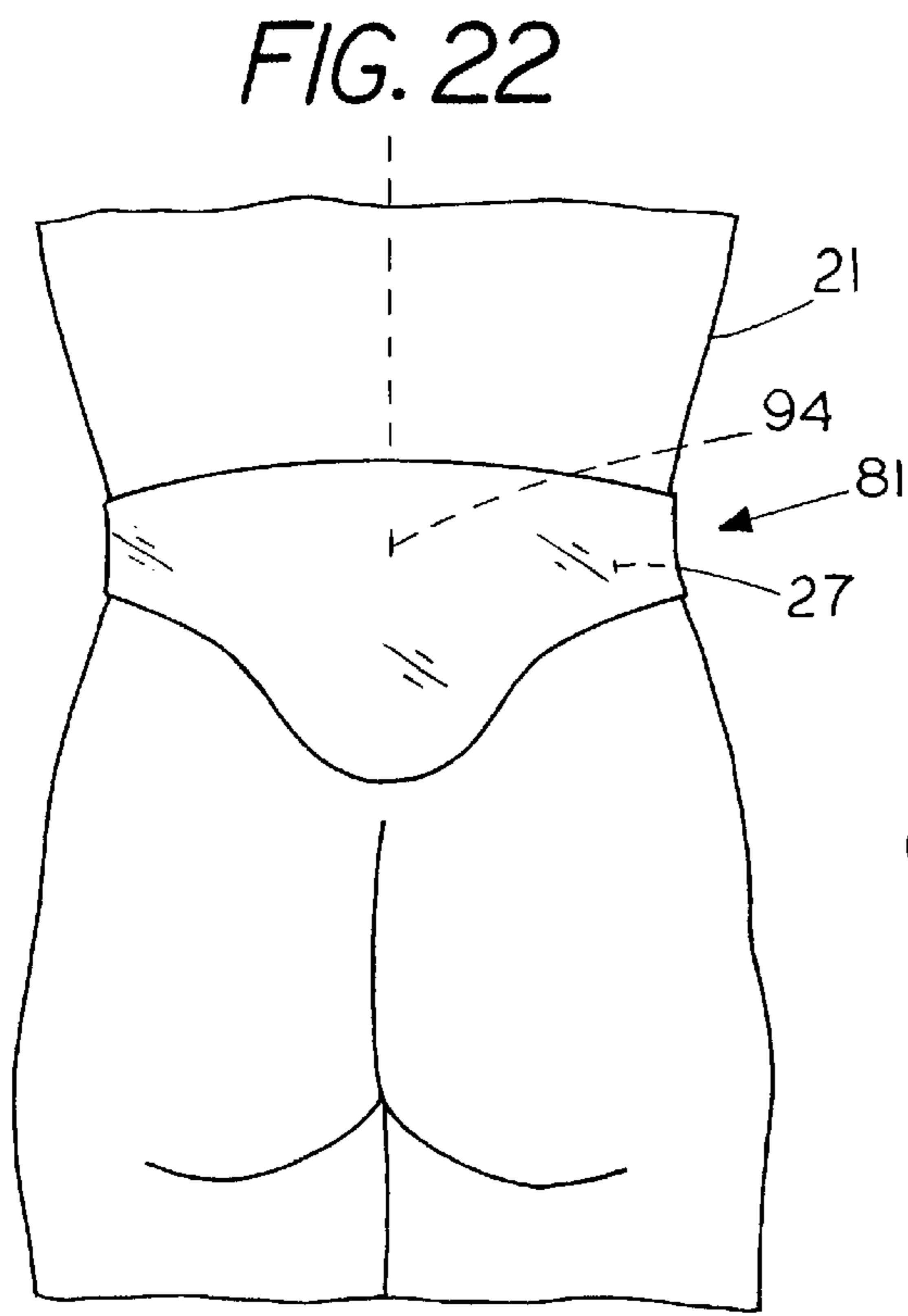
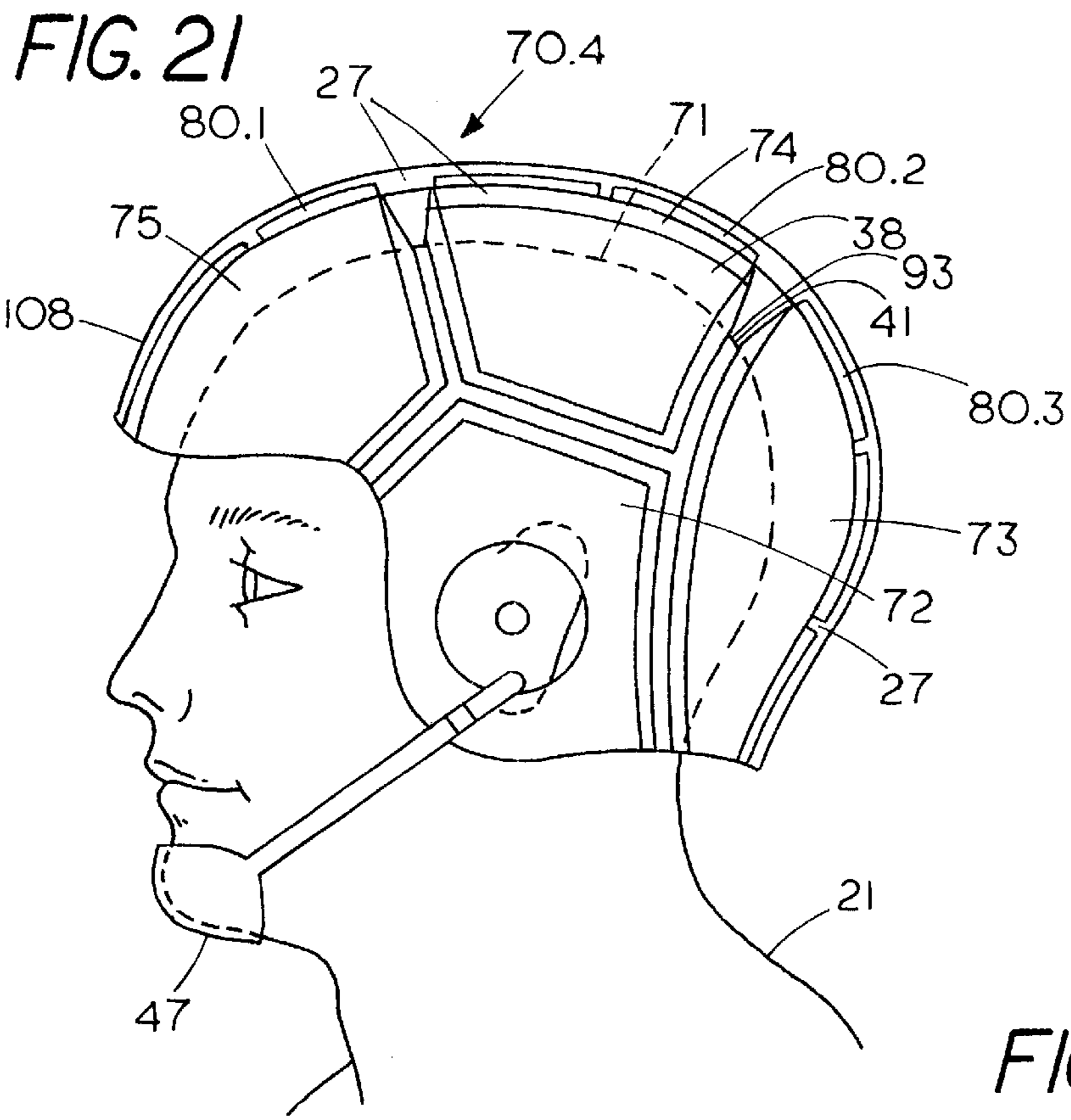

FIG. 24

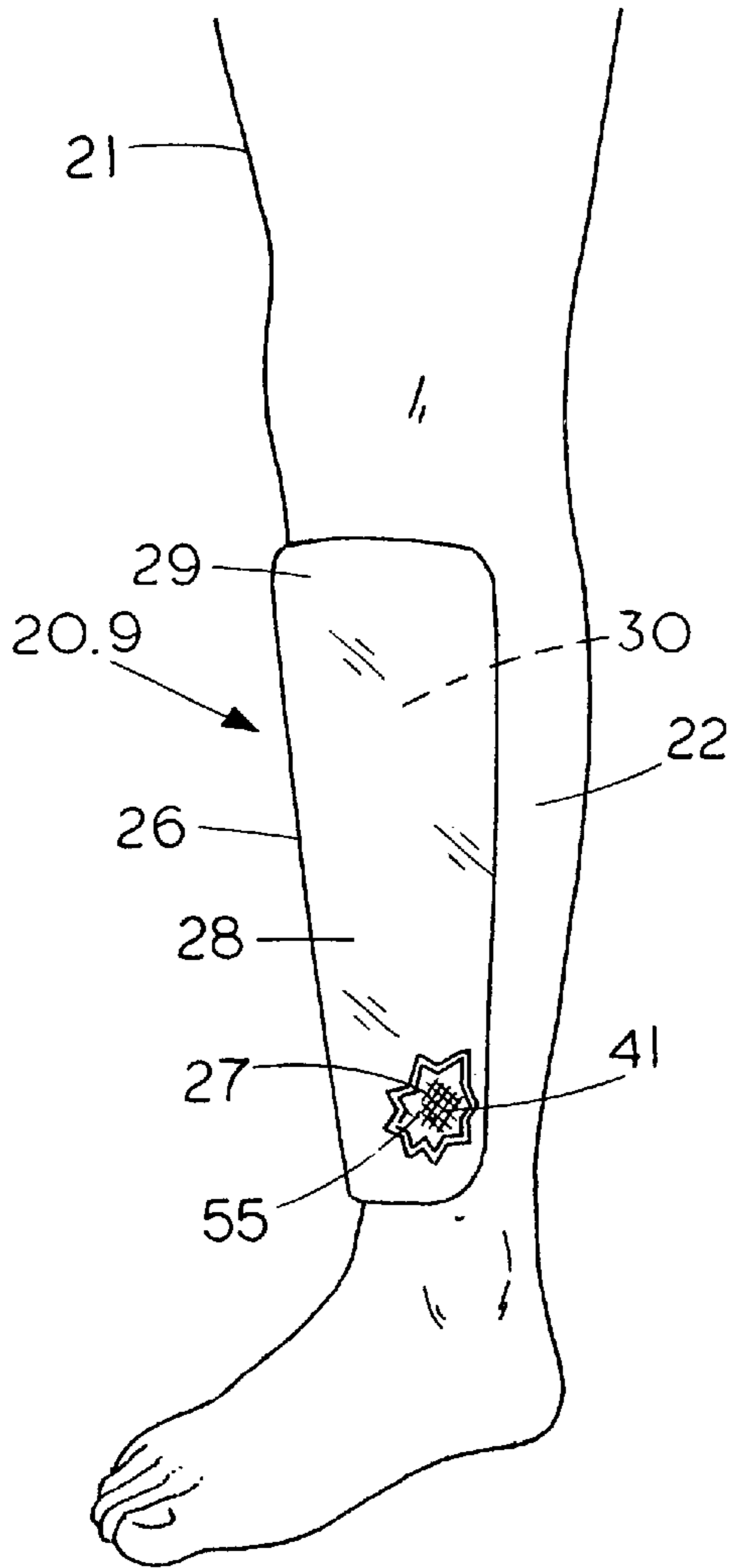

FIG. 25

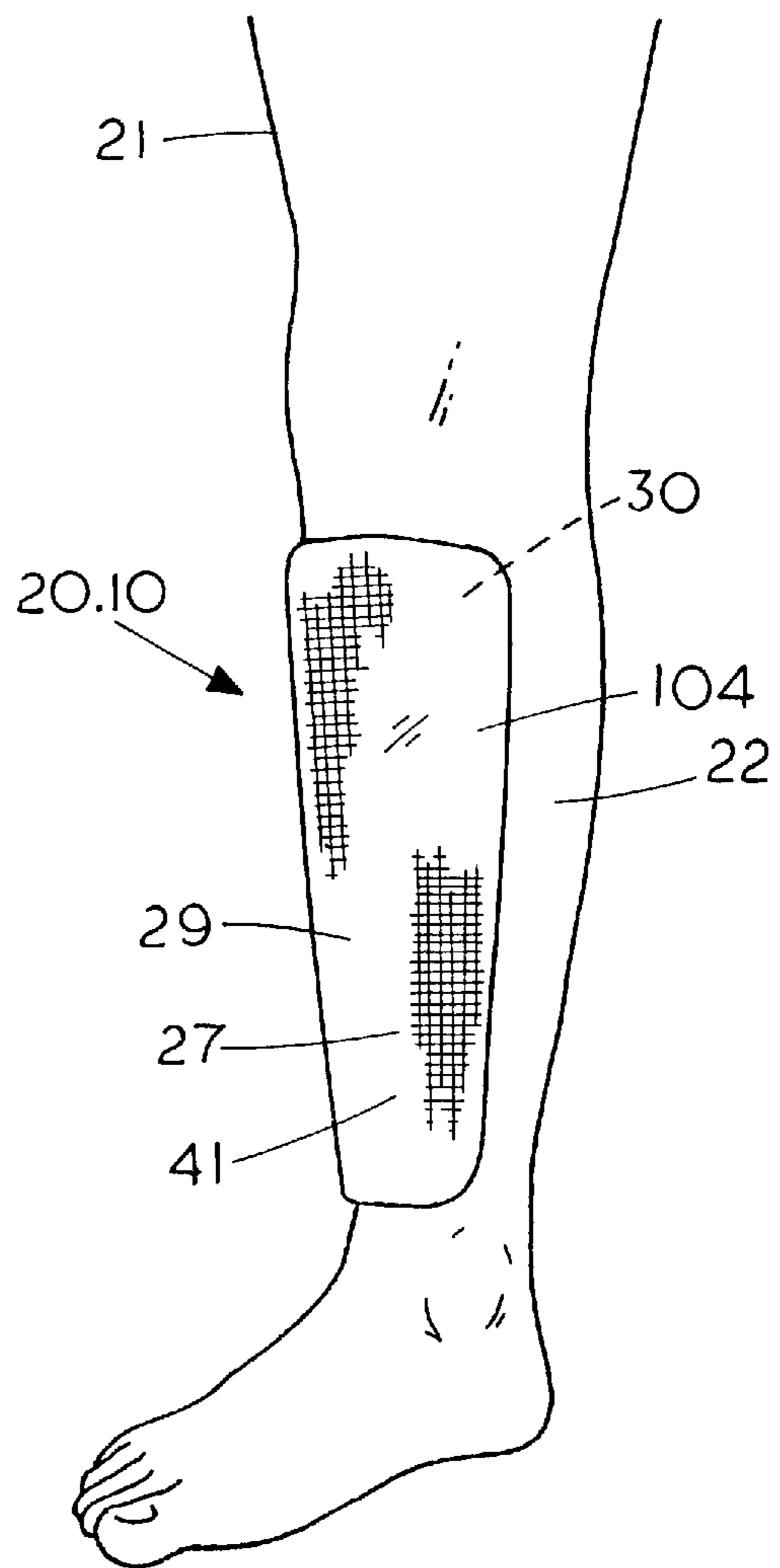

FIG. 26

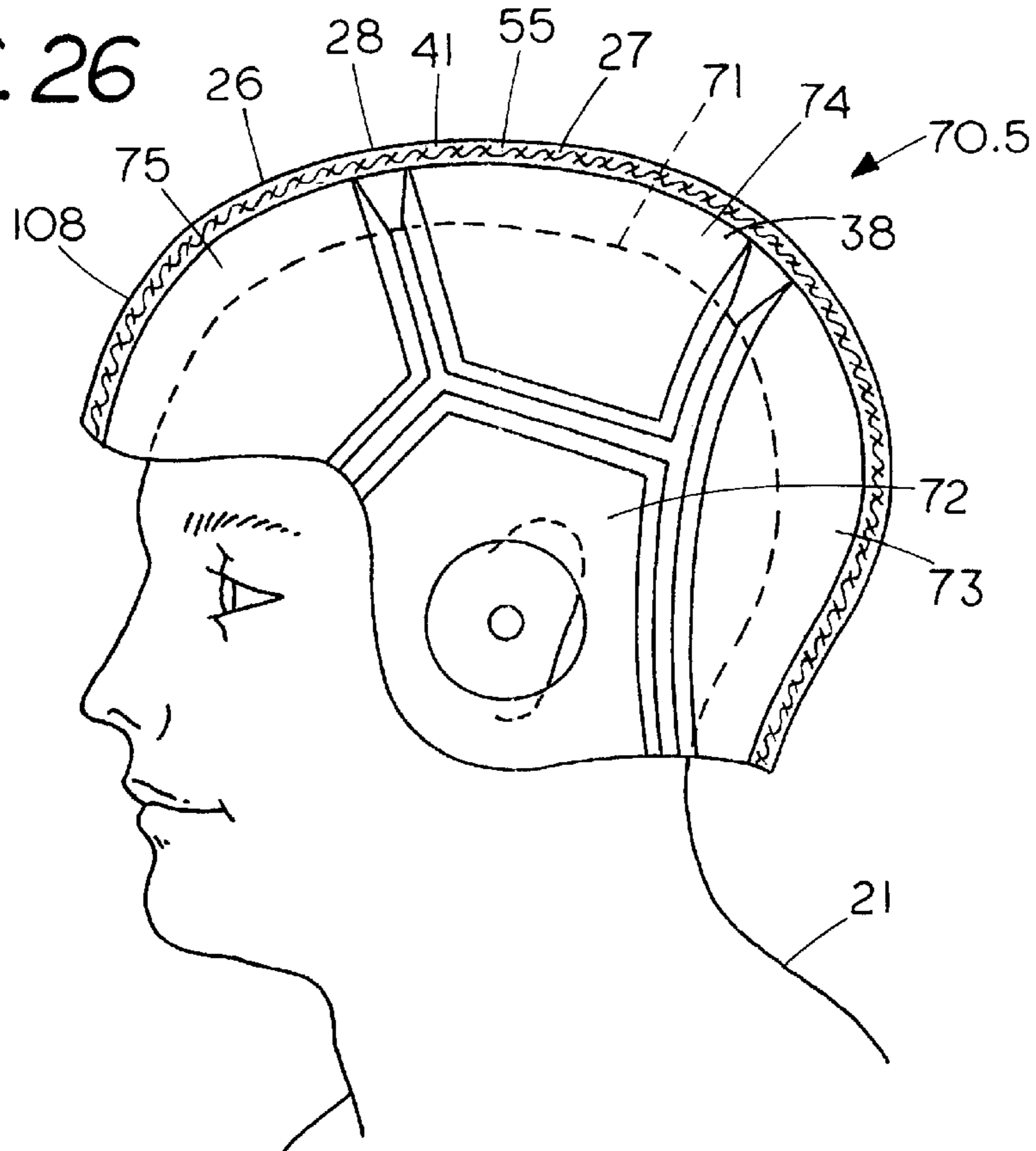

FIG. 27

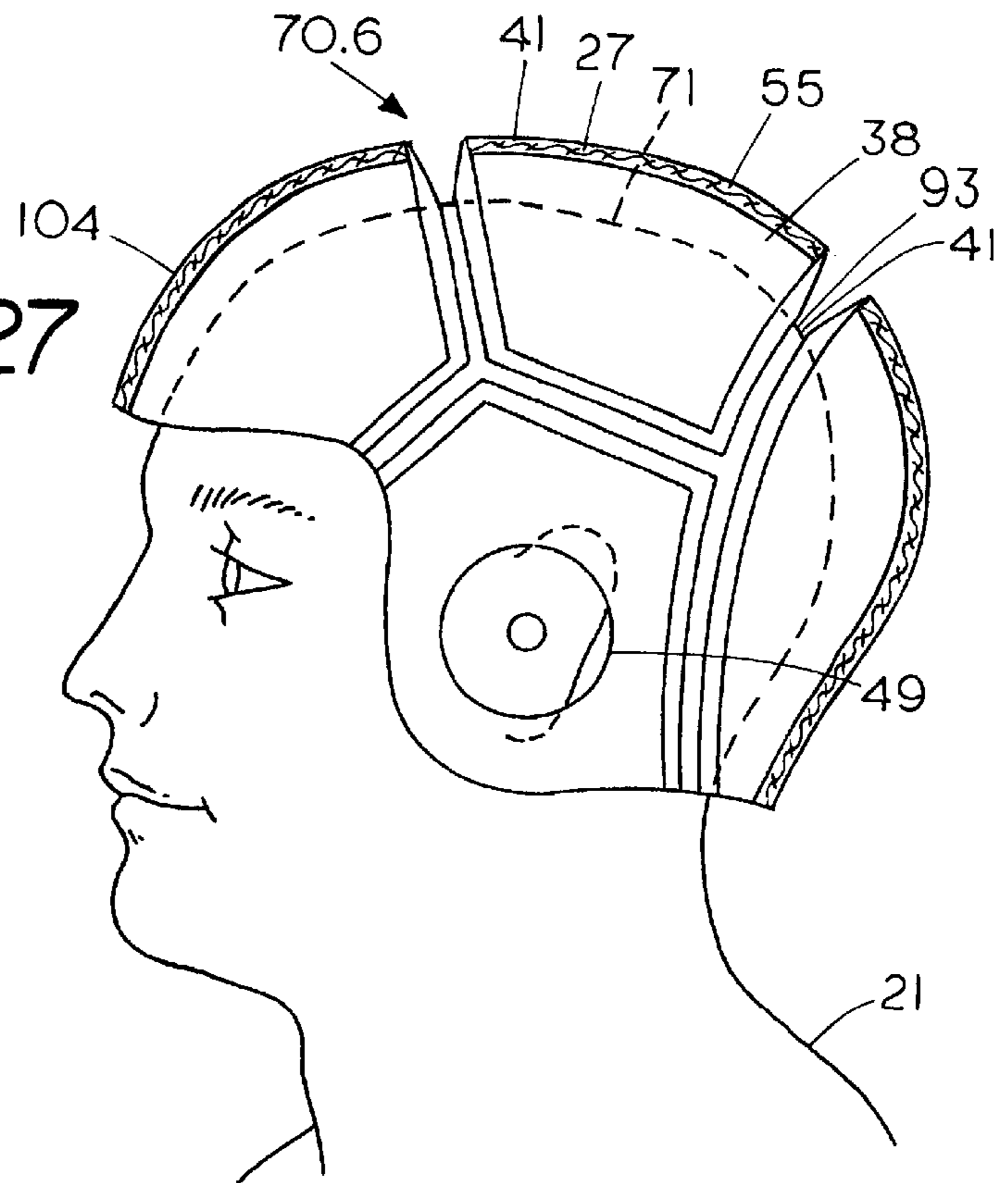

FIG. 28

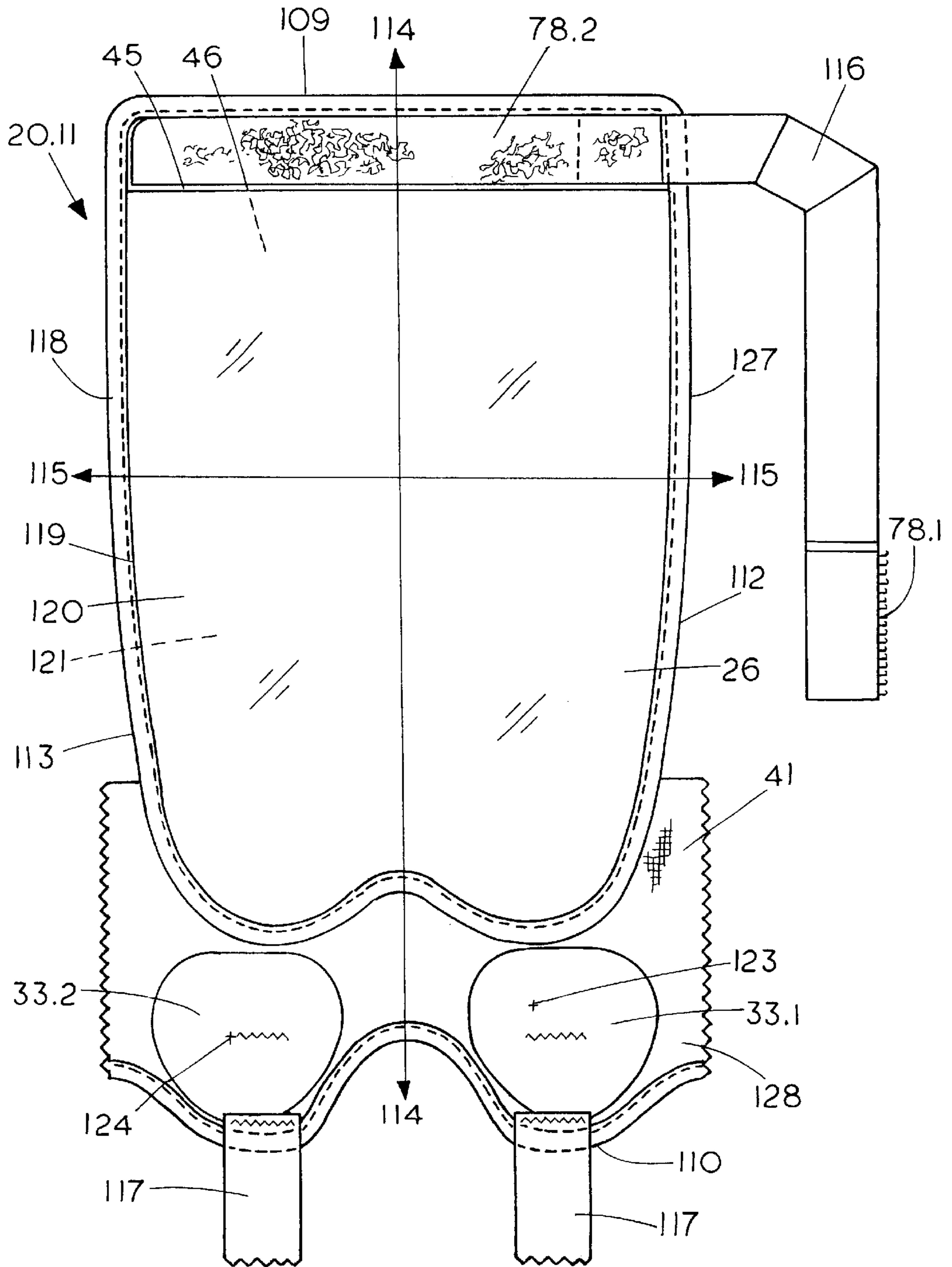

FIG. 29

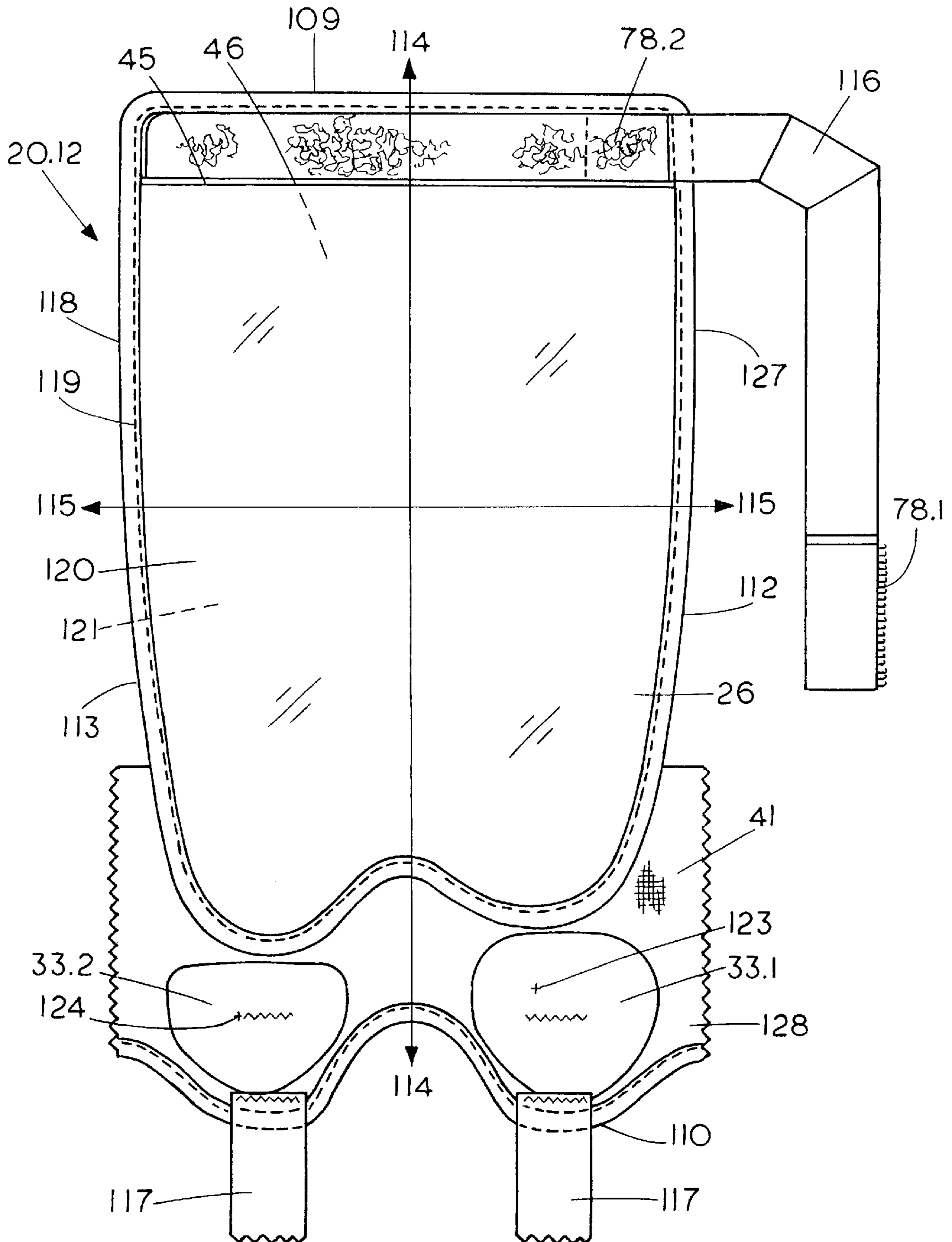



FIG. 30

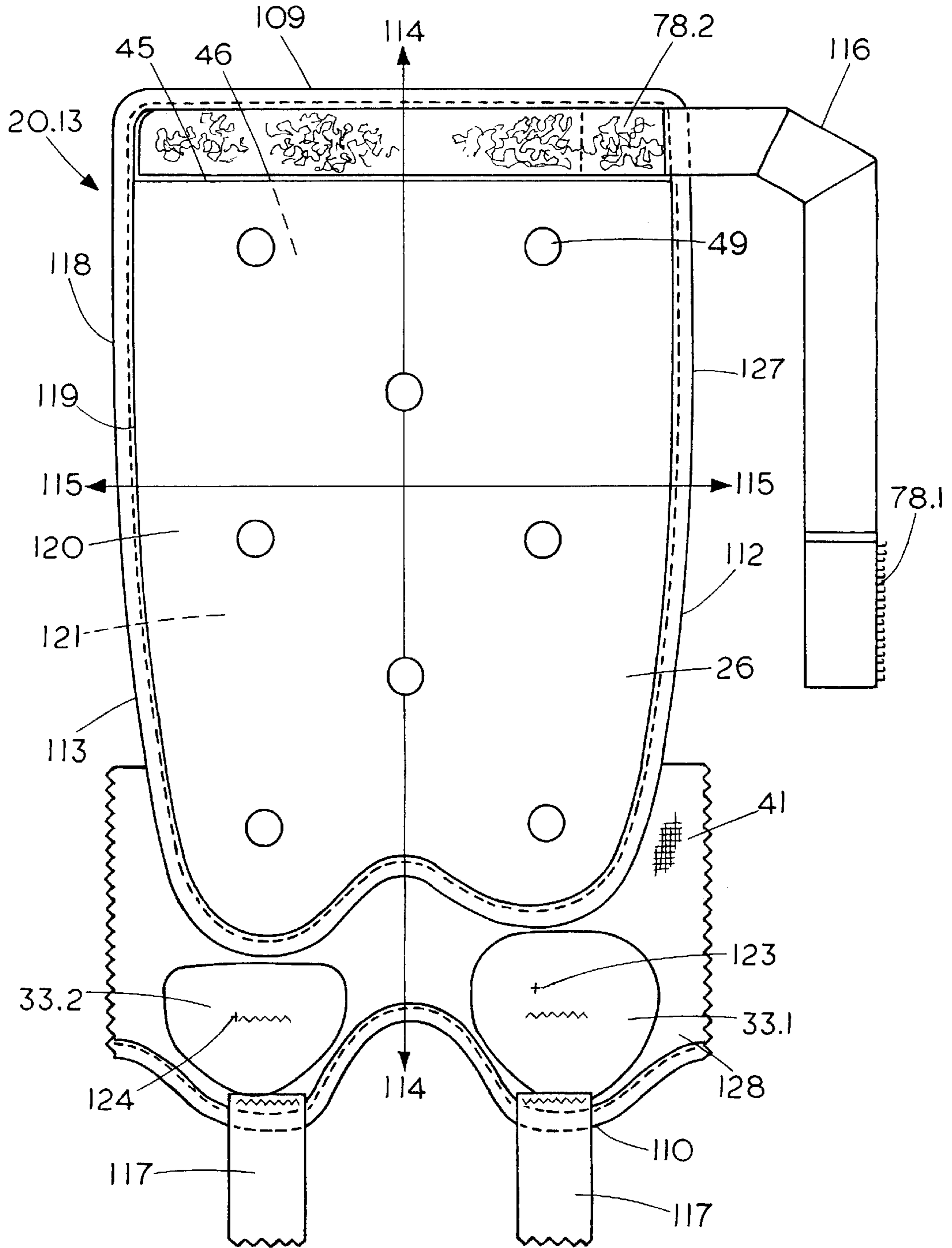

FIG. 31

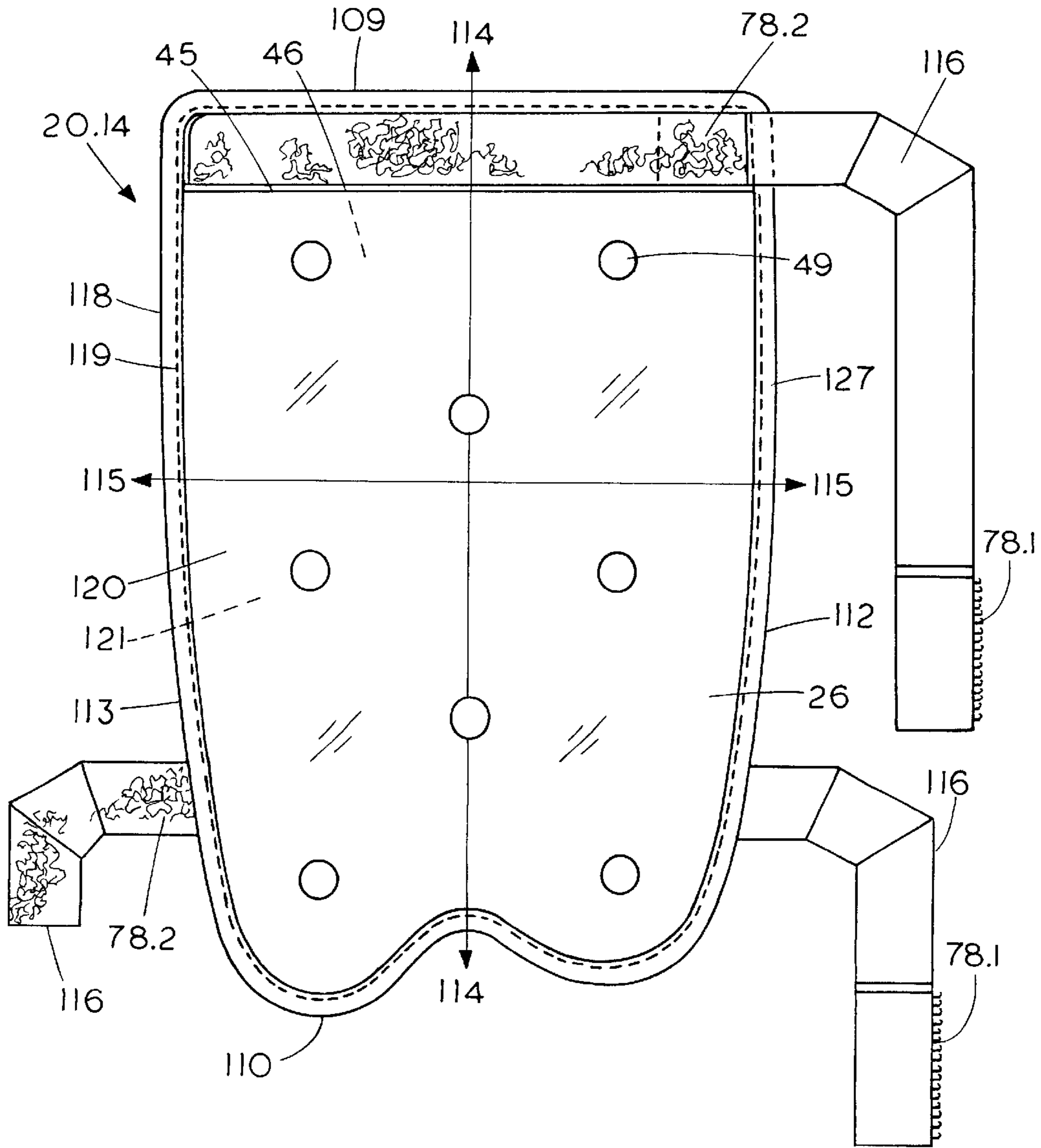

FIG. 32

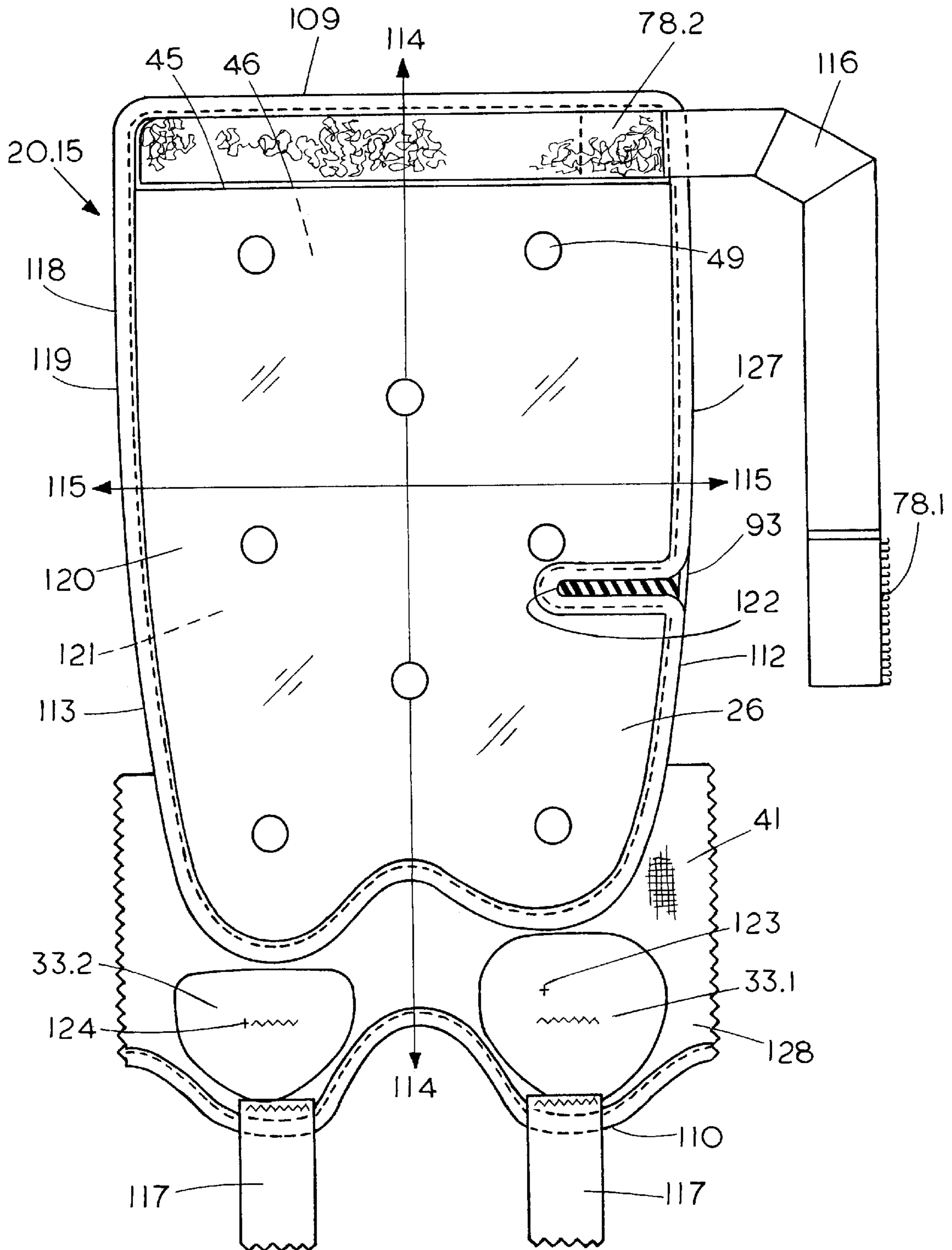

FIG. 33

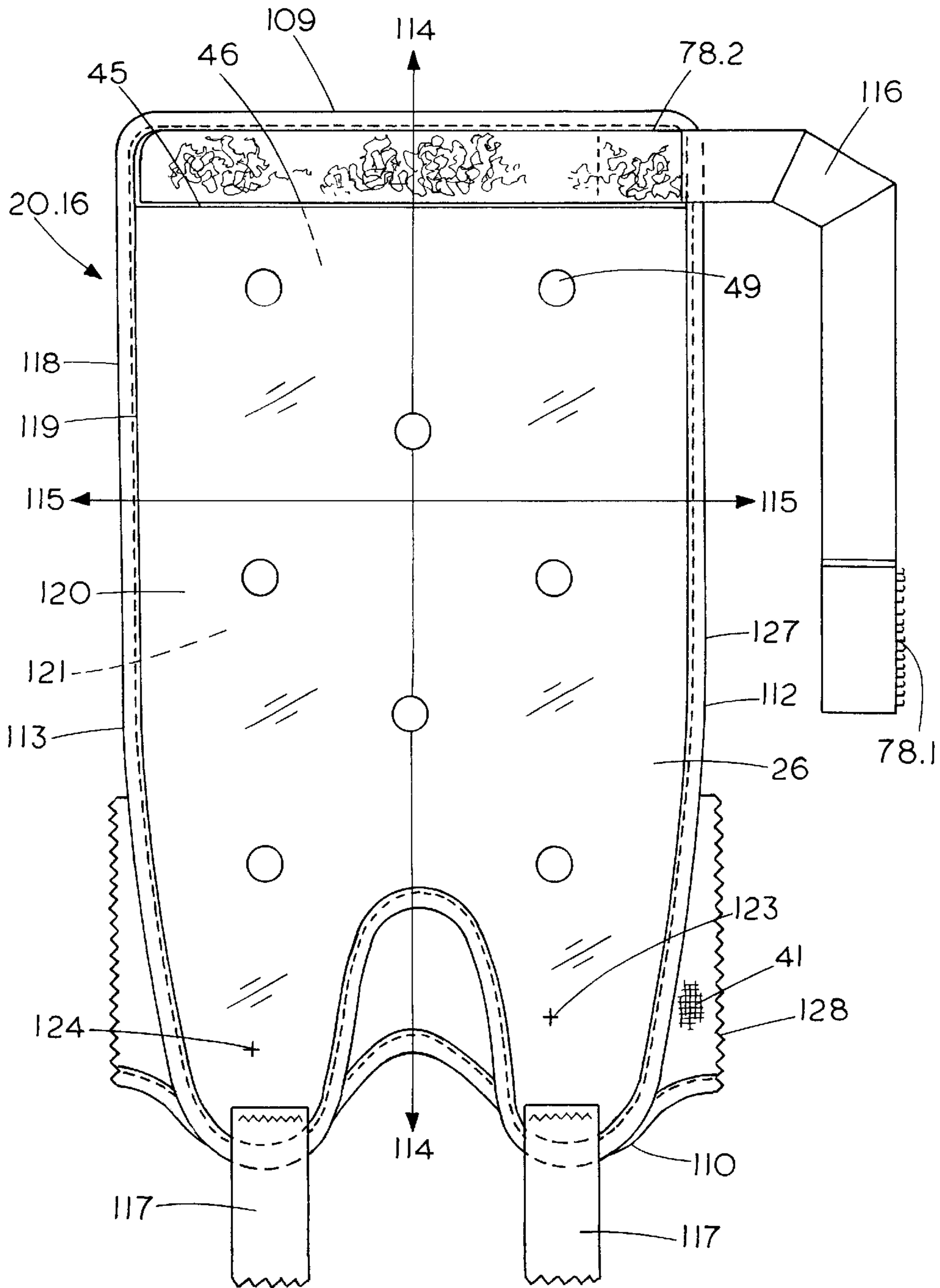

FIG. 34

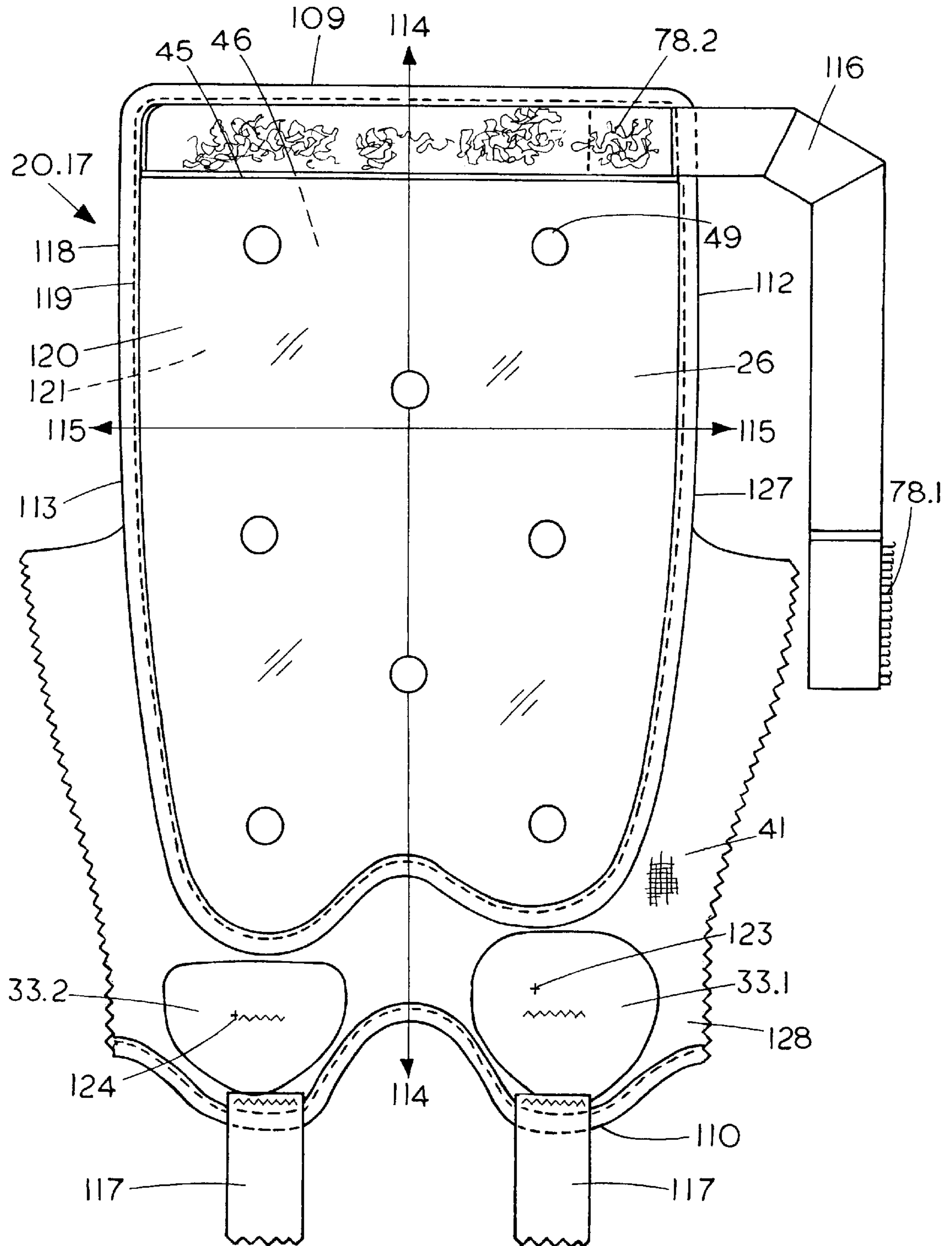

FIG. 35

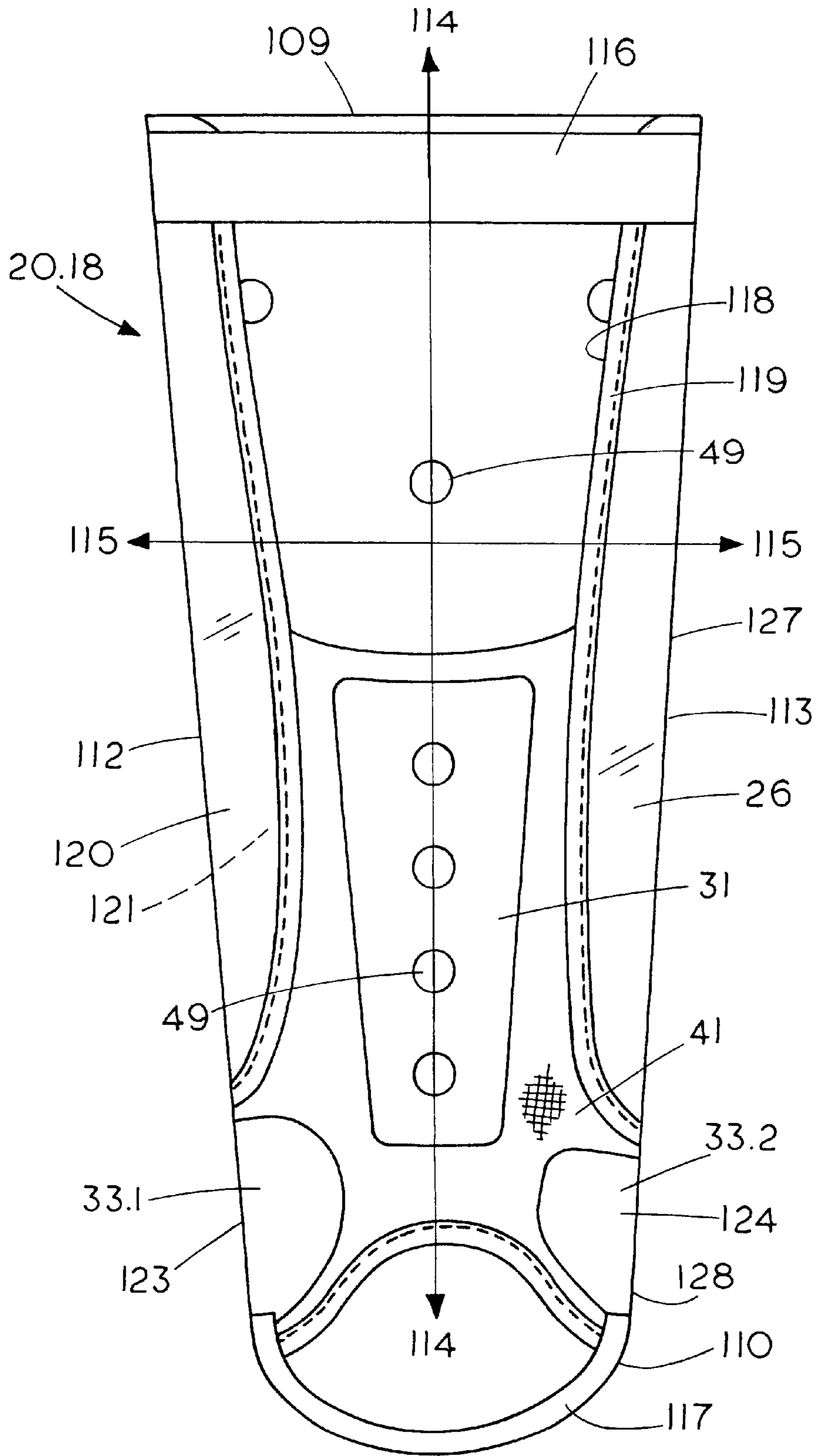

FIG. 36

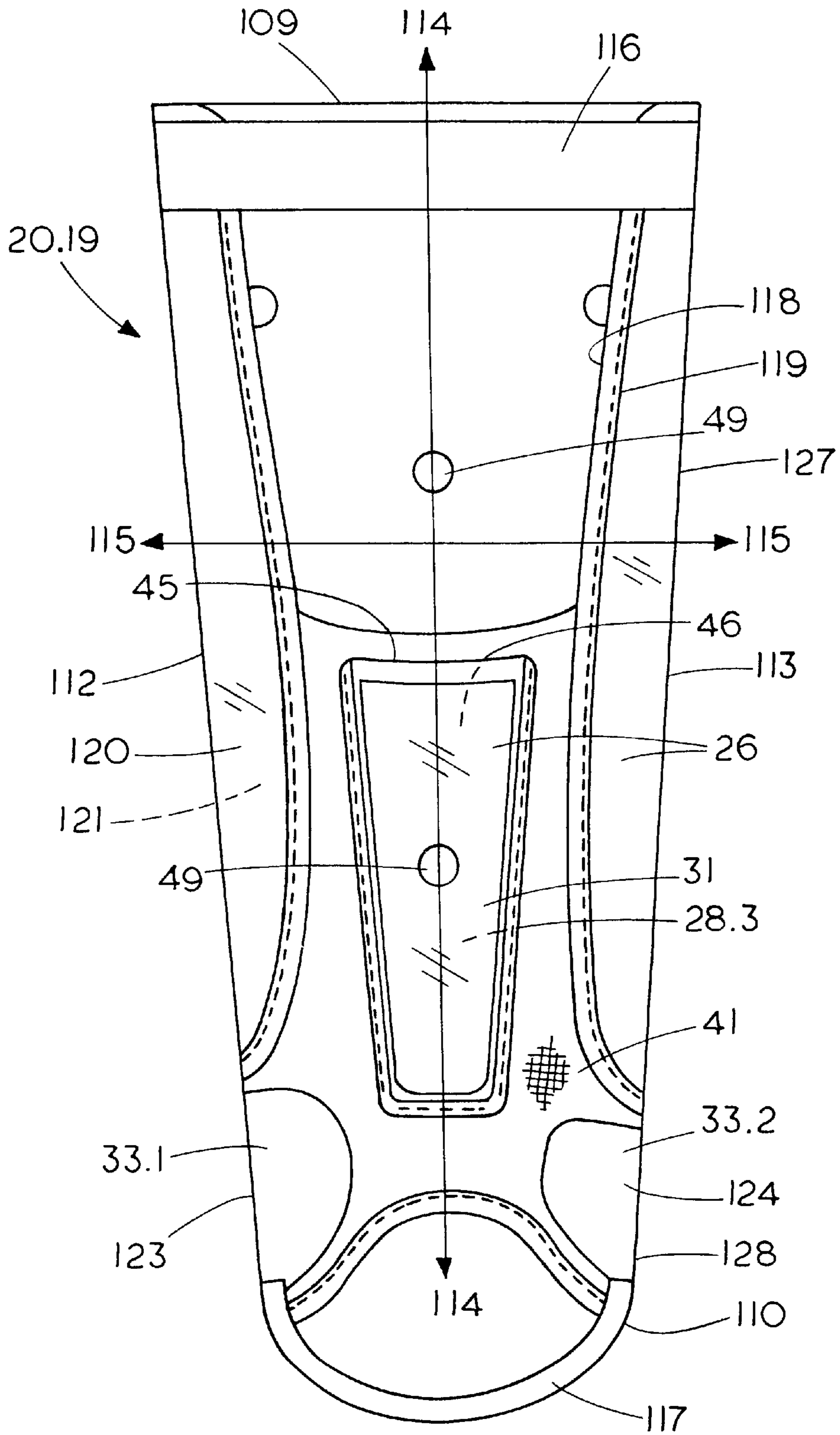

FIG. 37

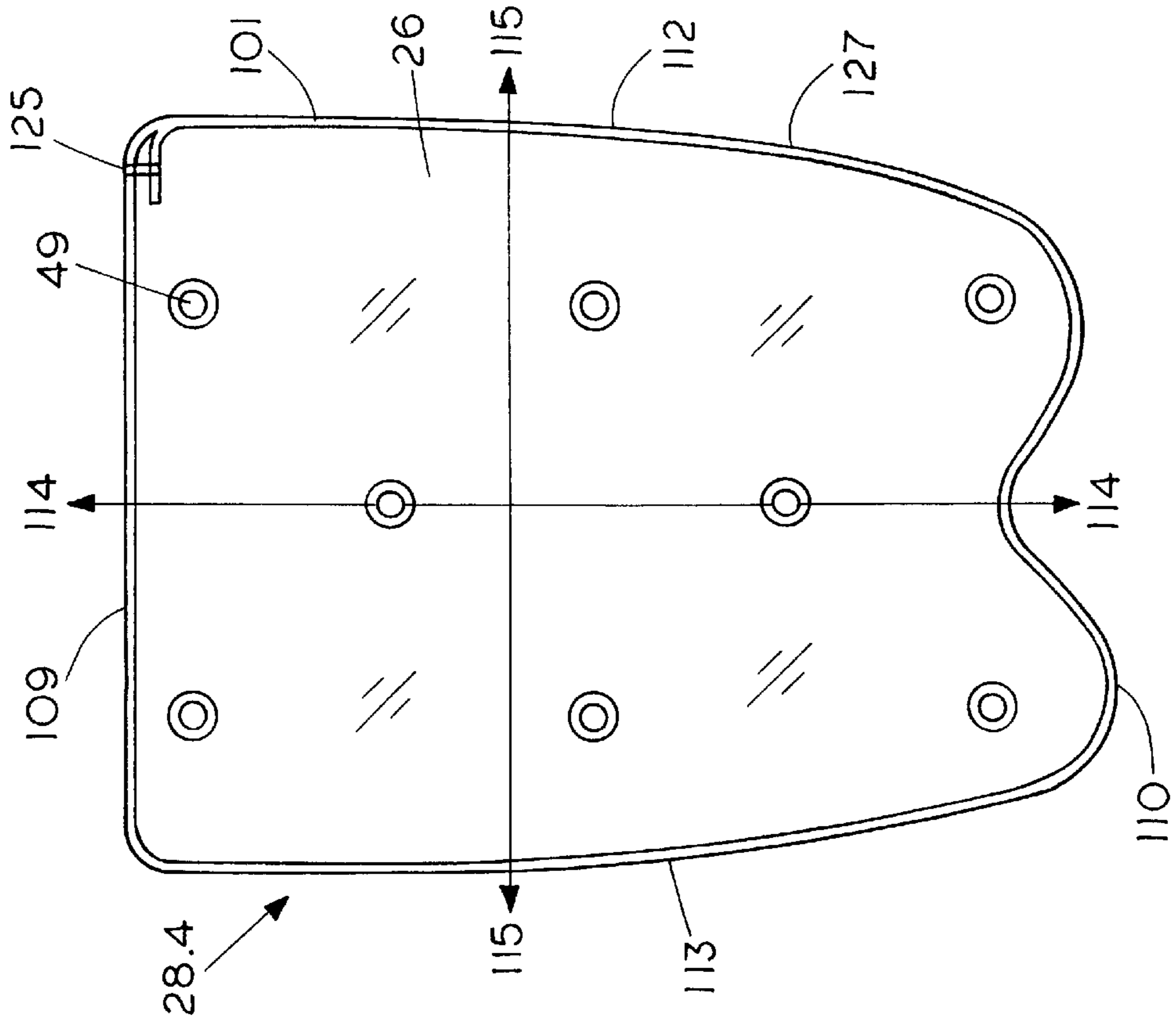

FIG. 38

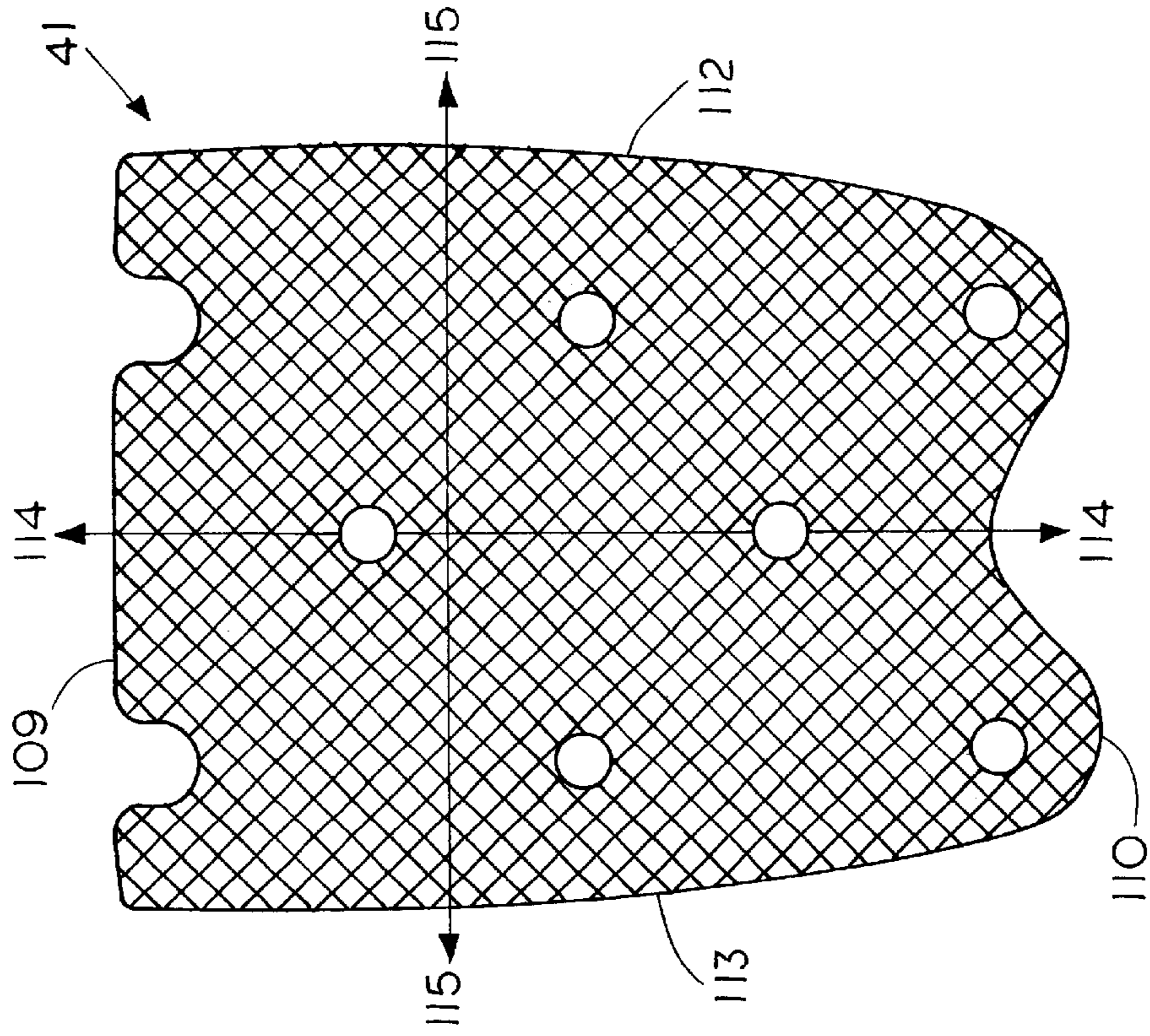



FIG. 39

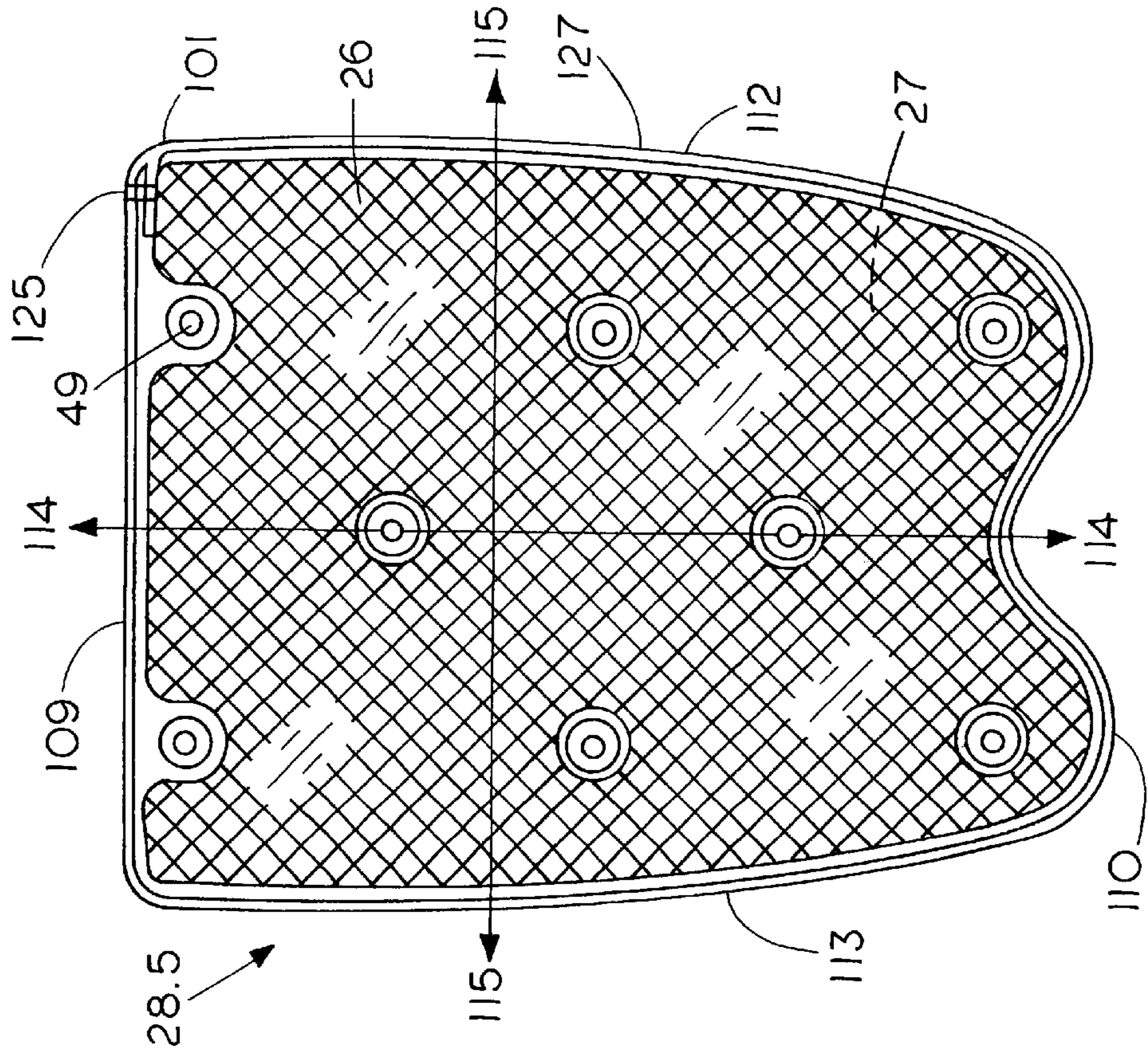

FIG. 40

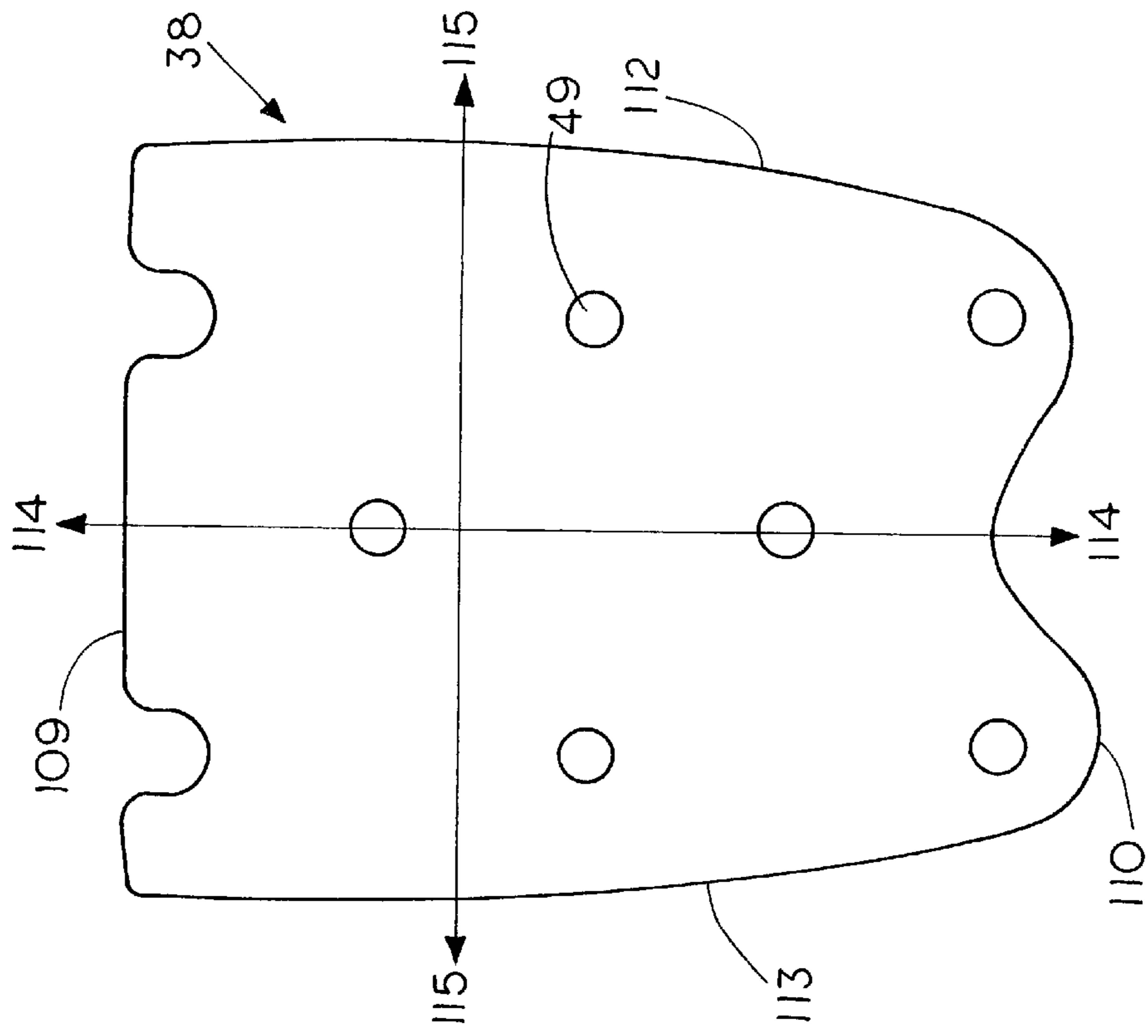

FIG. 42

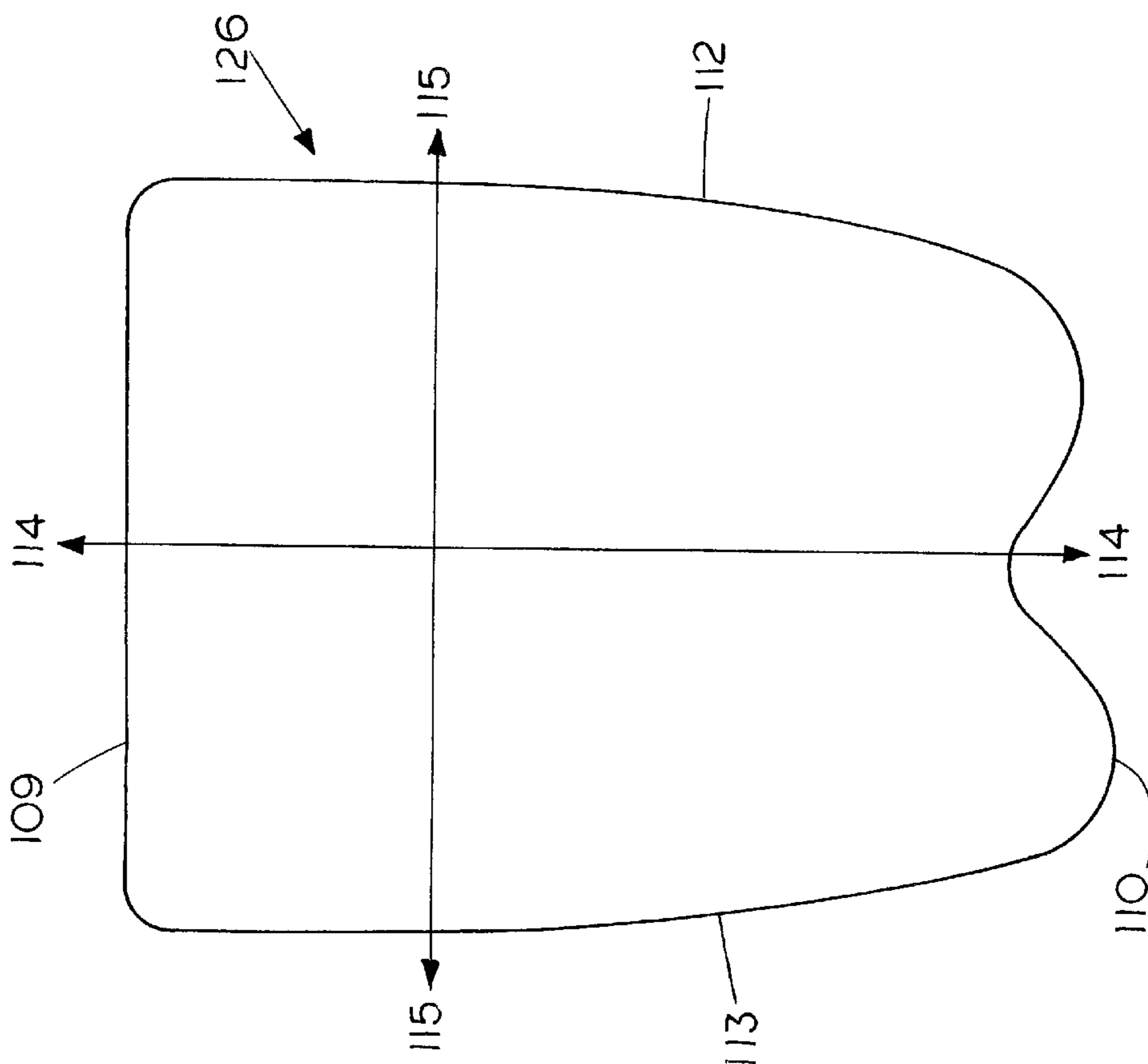

FIG. 41

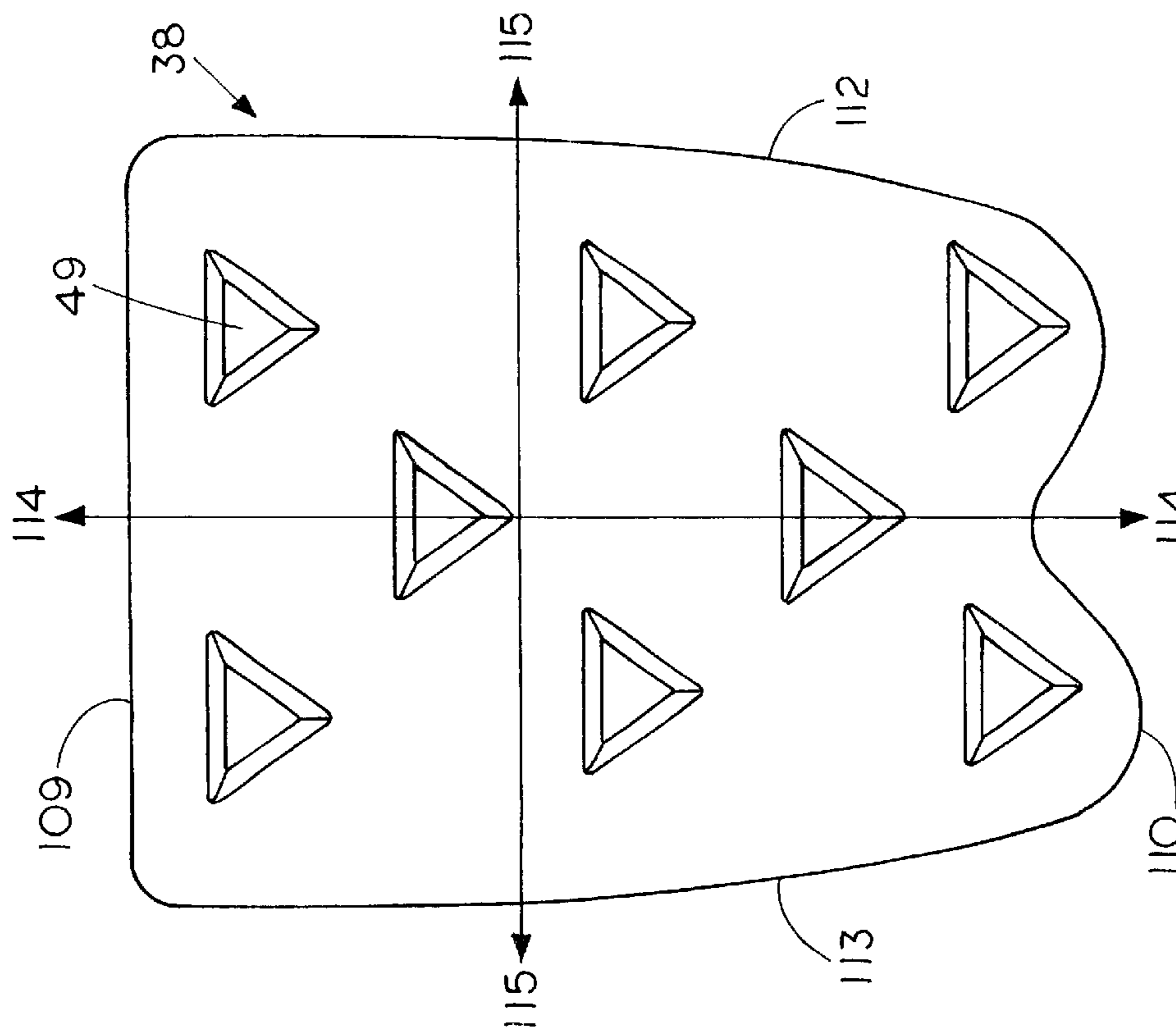

FIG. 43

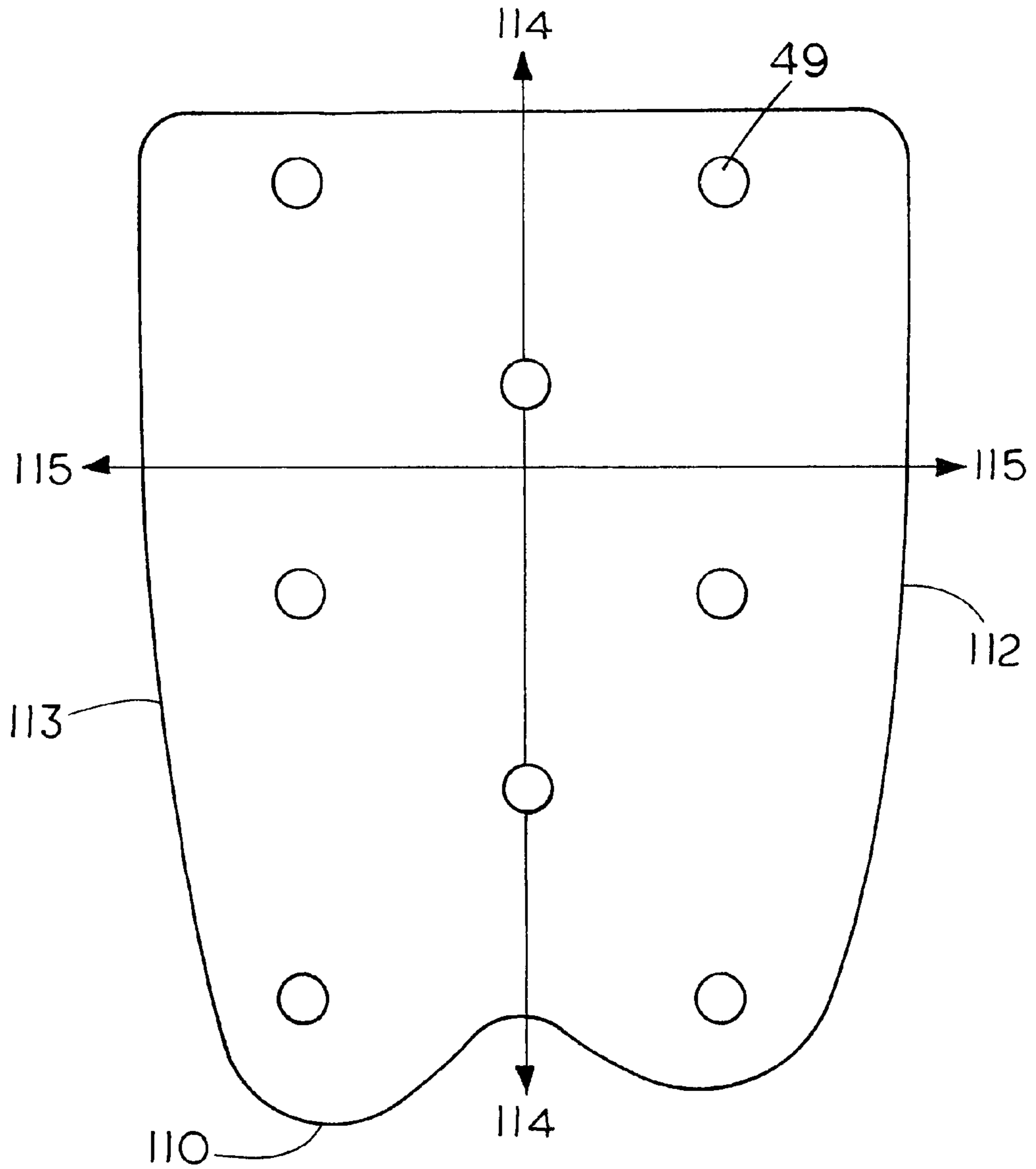

FIG. 44

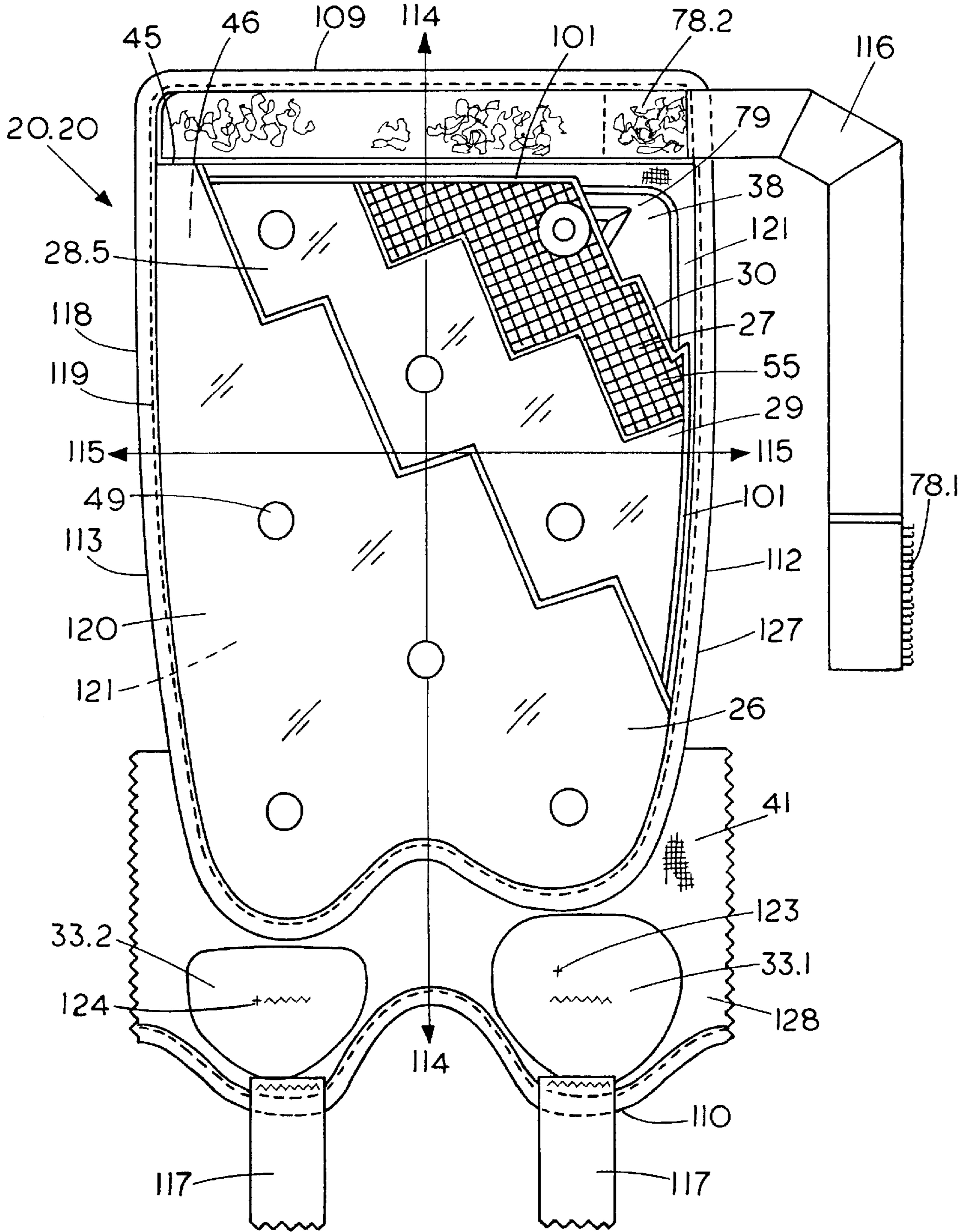

FIG. 45

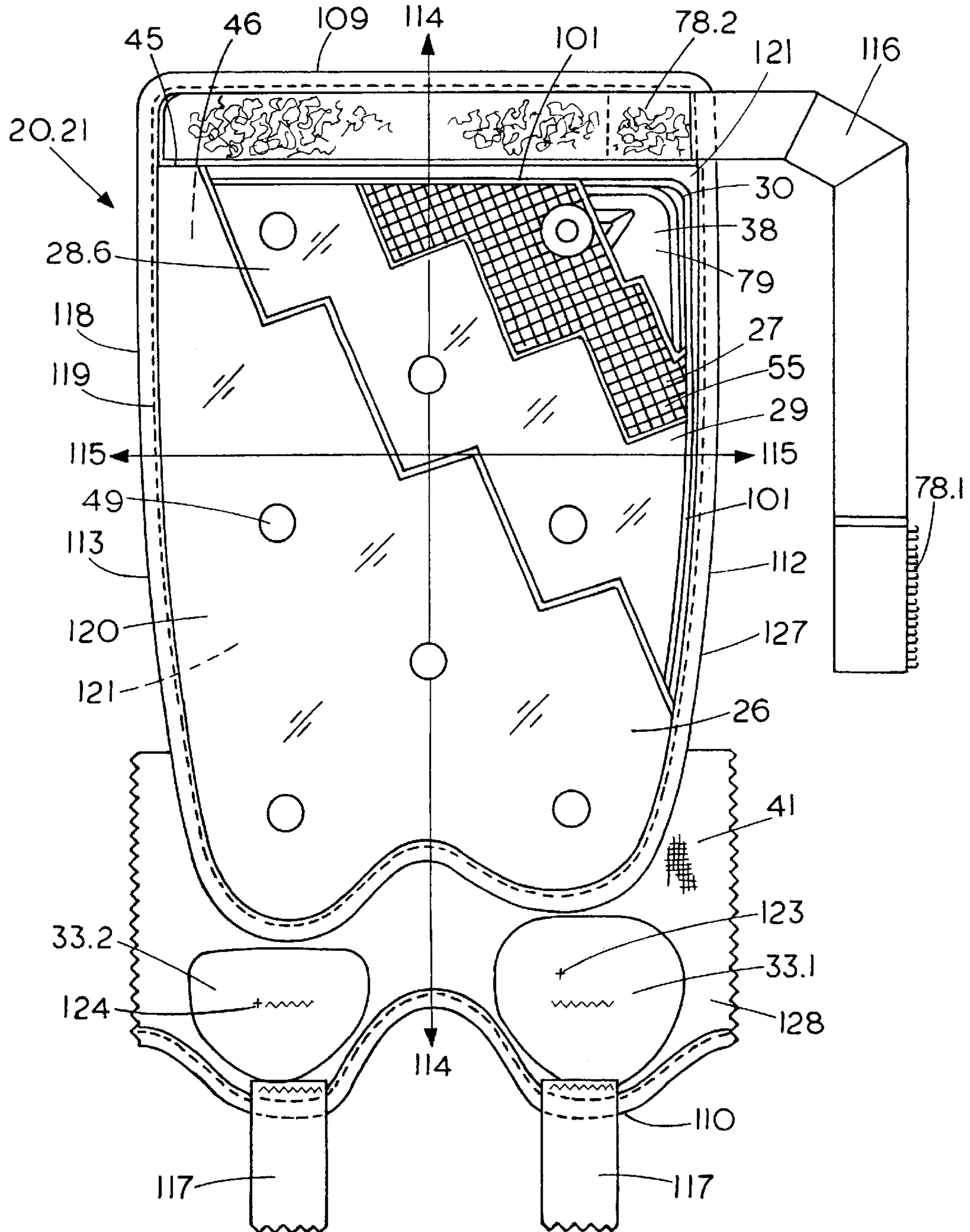

FIG. 46

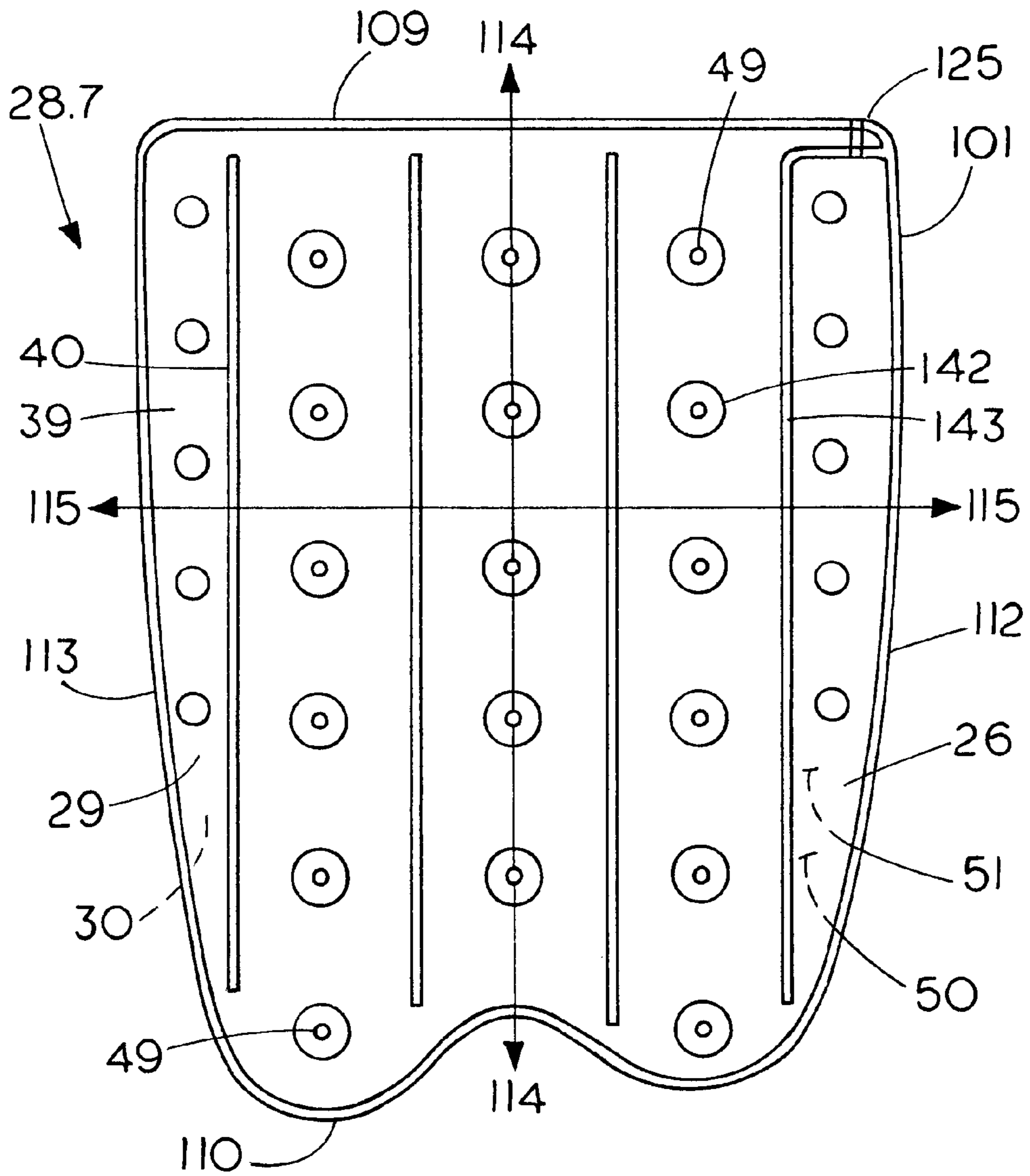

FIG. 47

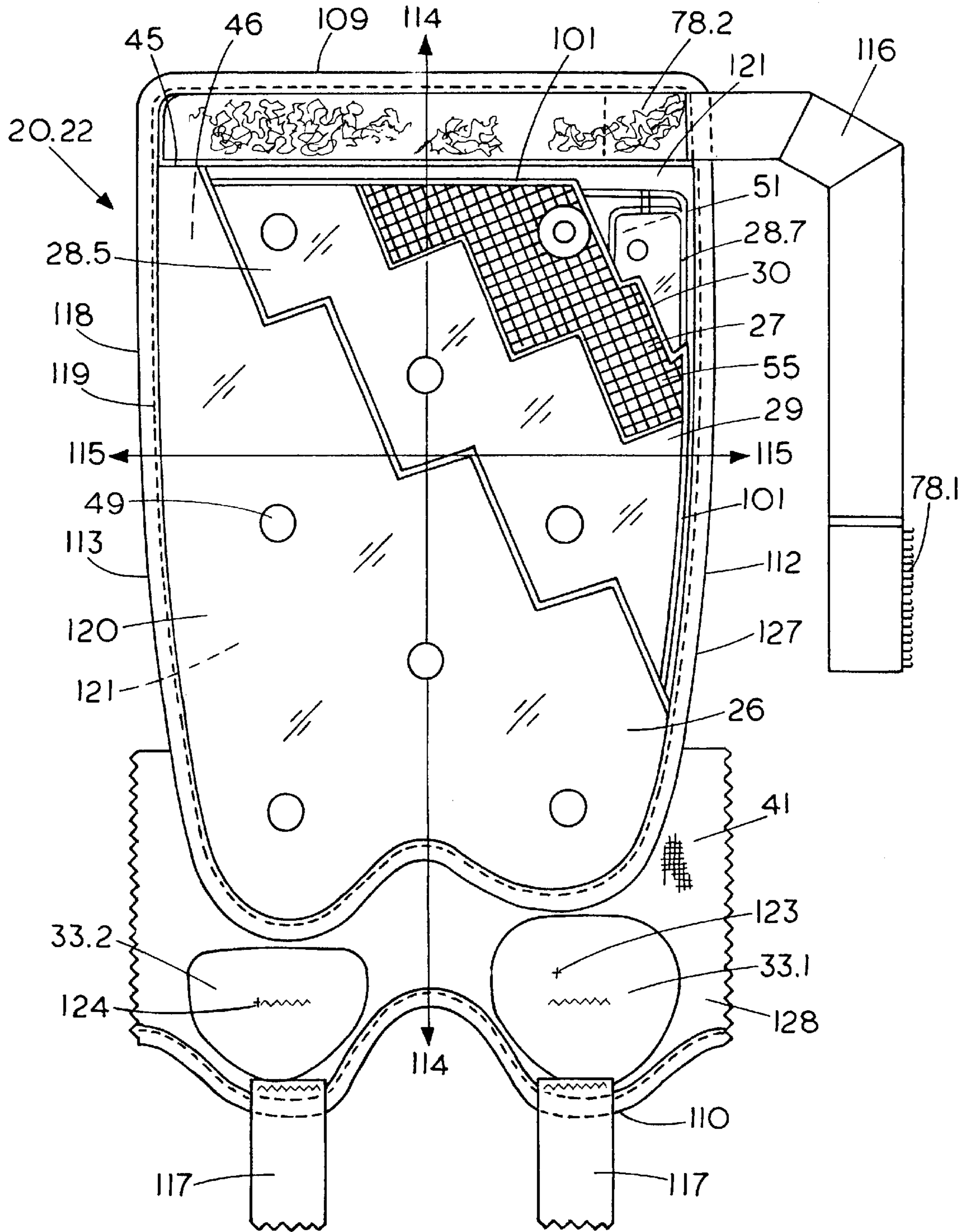

FIG. 48

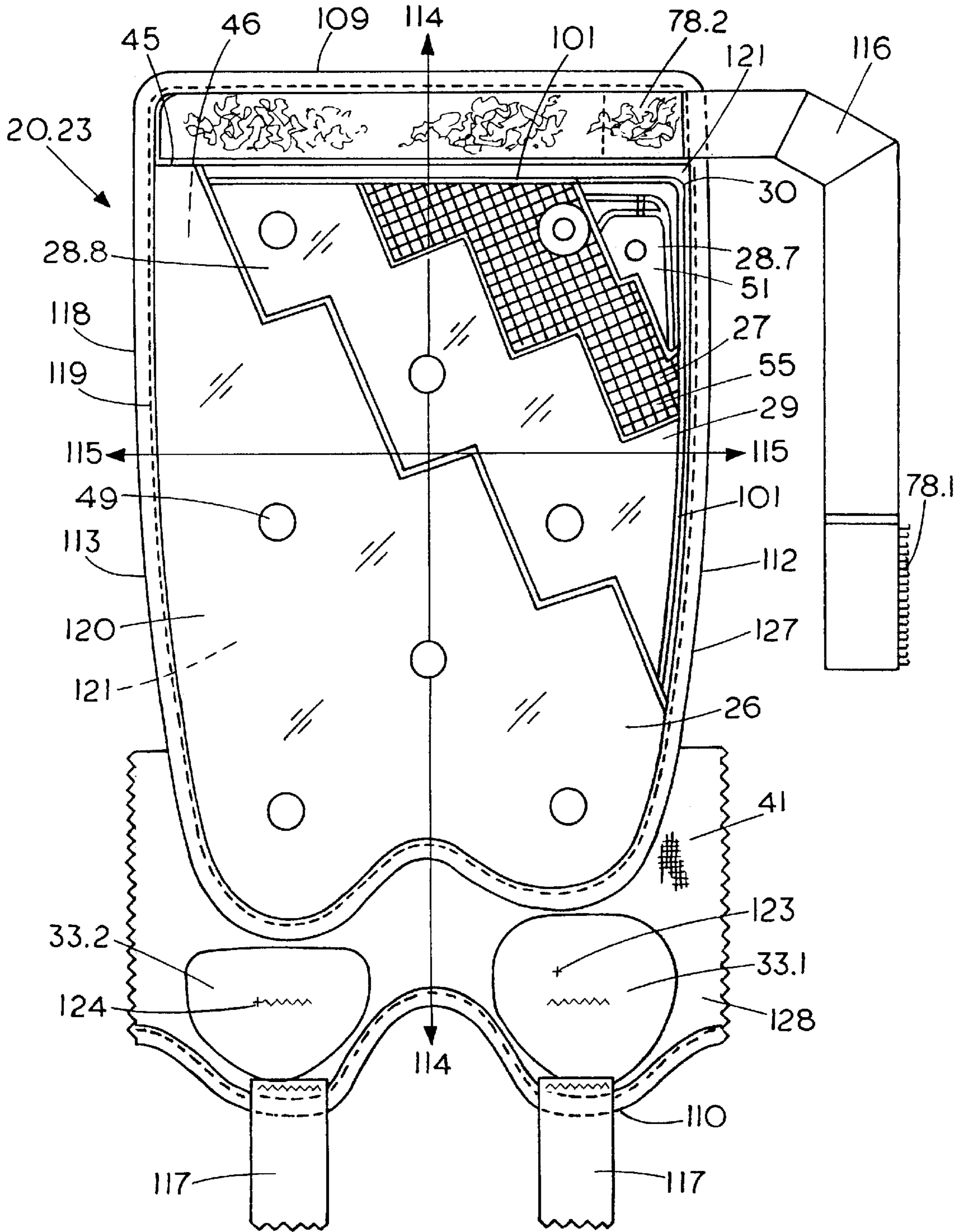



FIG. 49

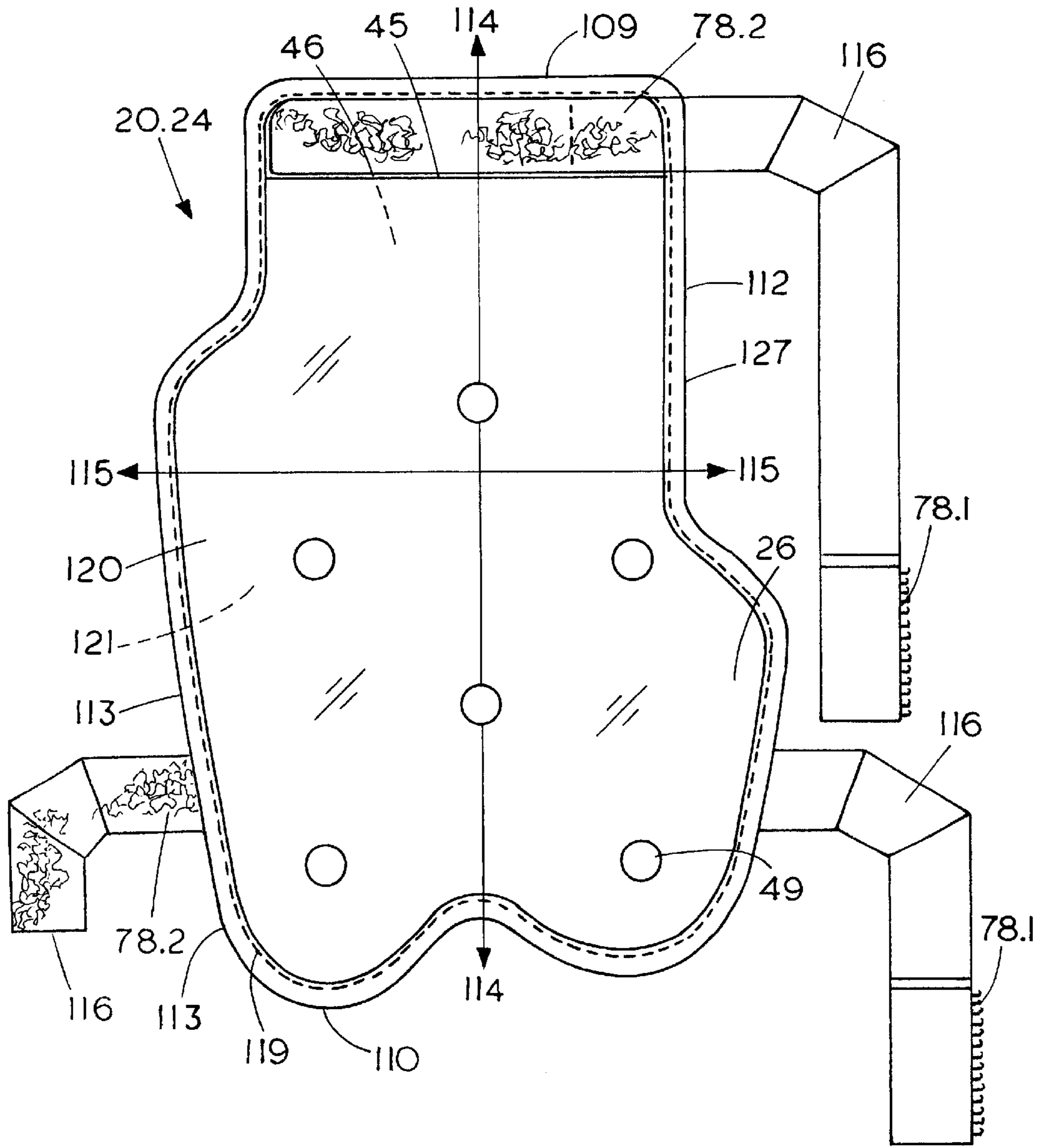

FIG. 50

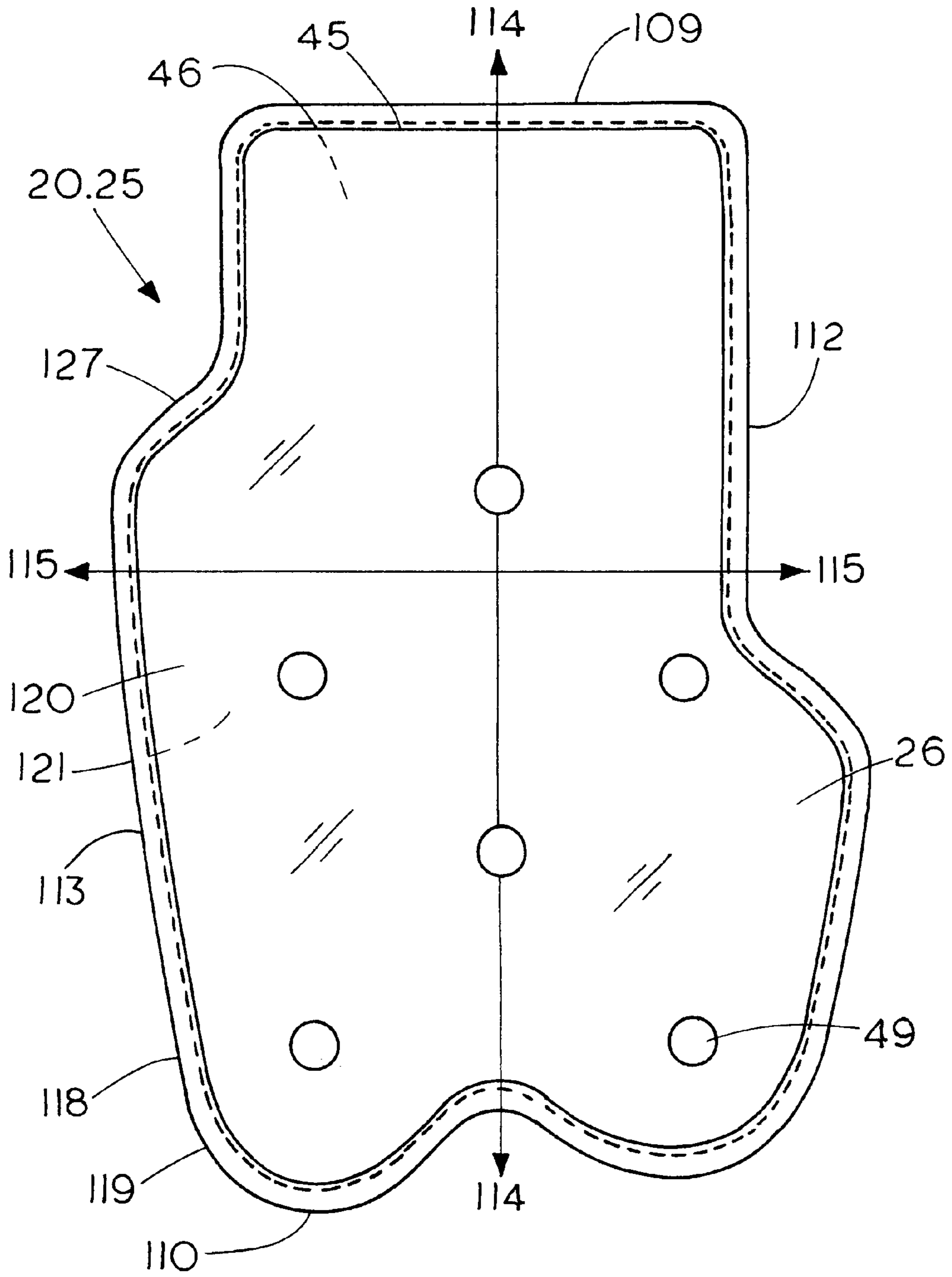

FIG. 51

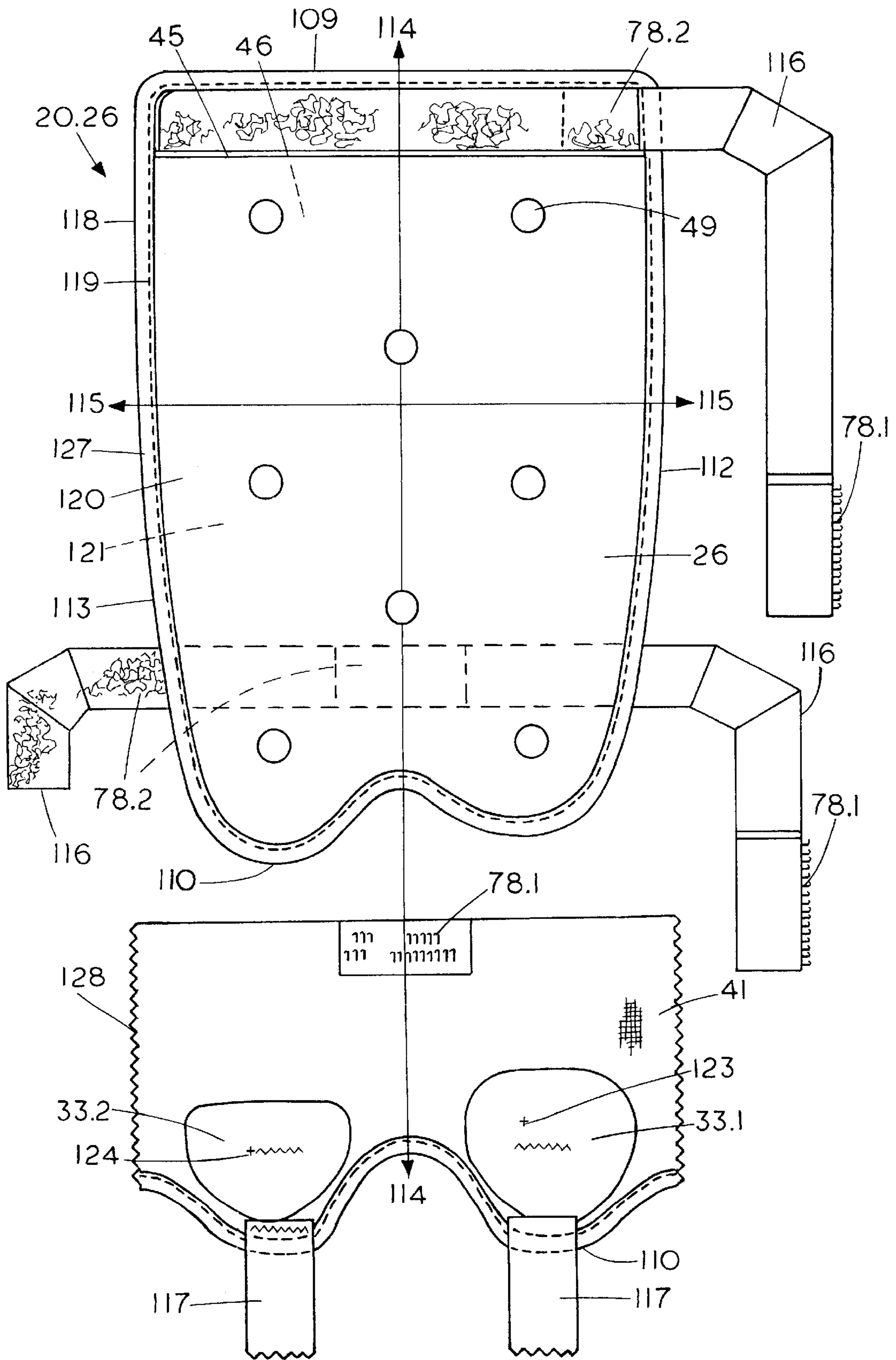

FIG. 52

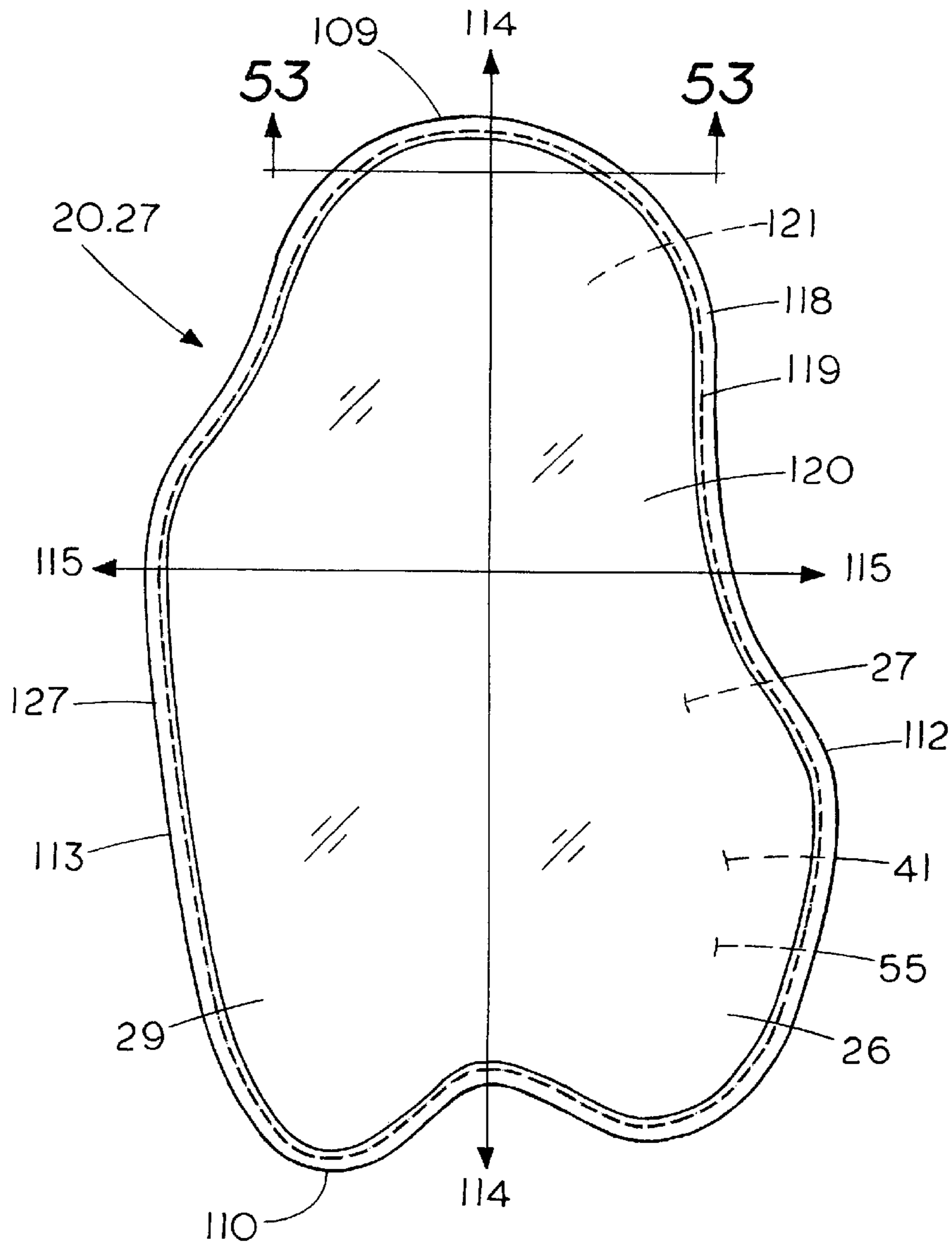

FIG. 53

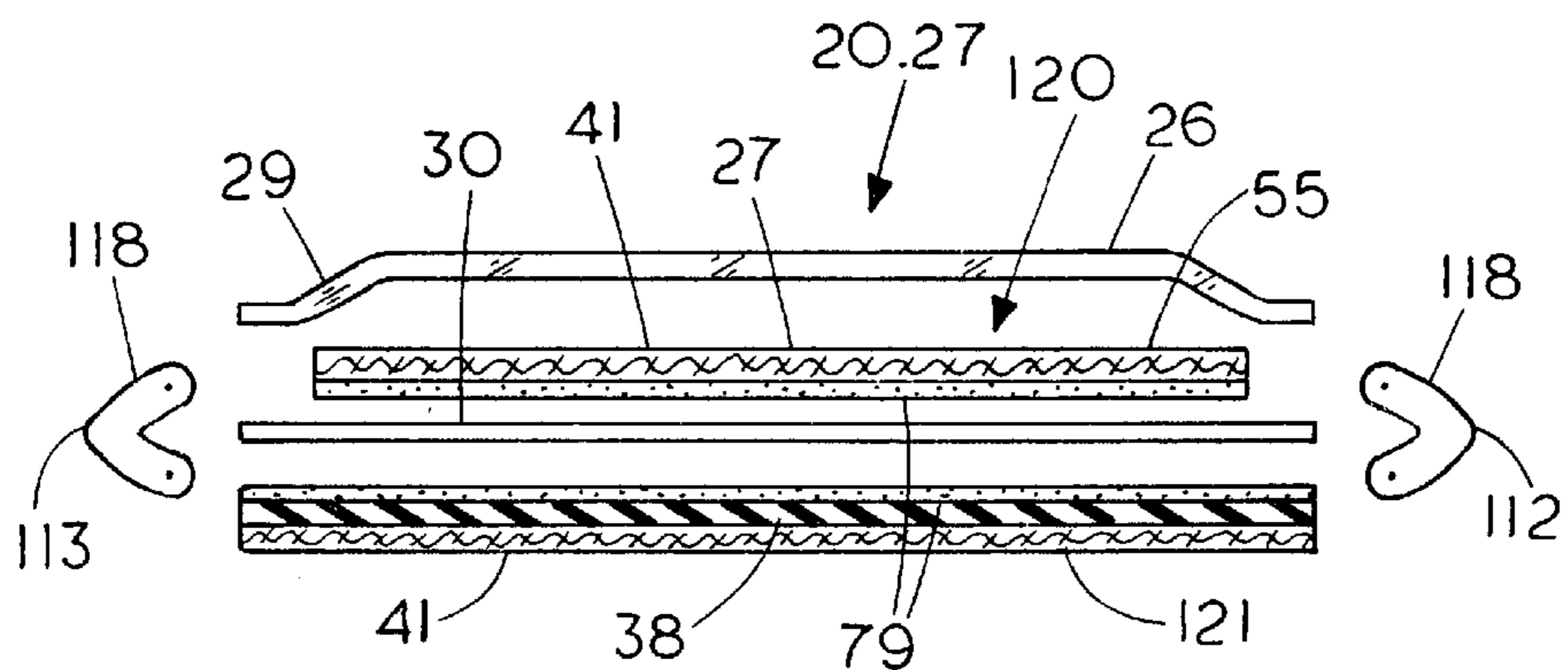

FIG. 54

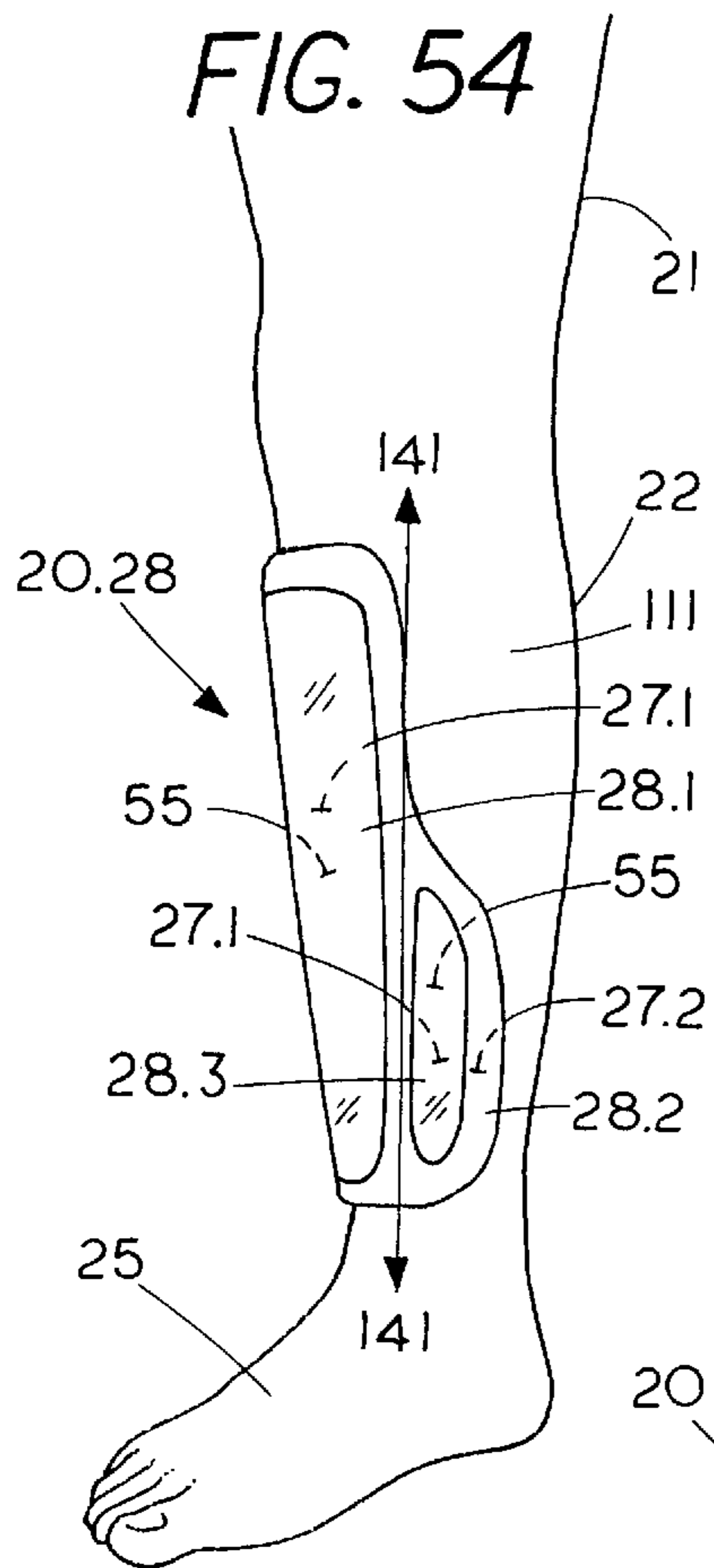

FIG. 55

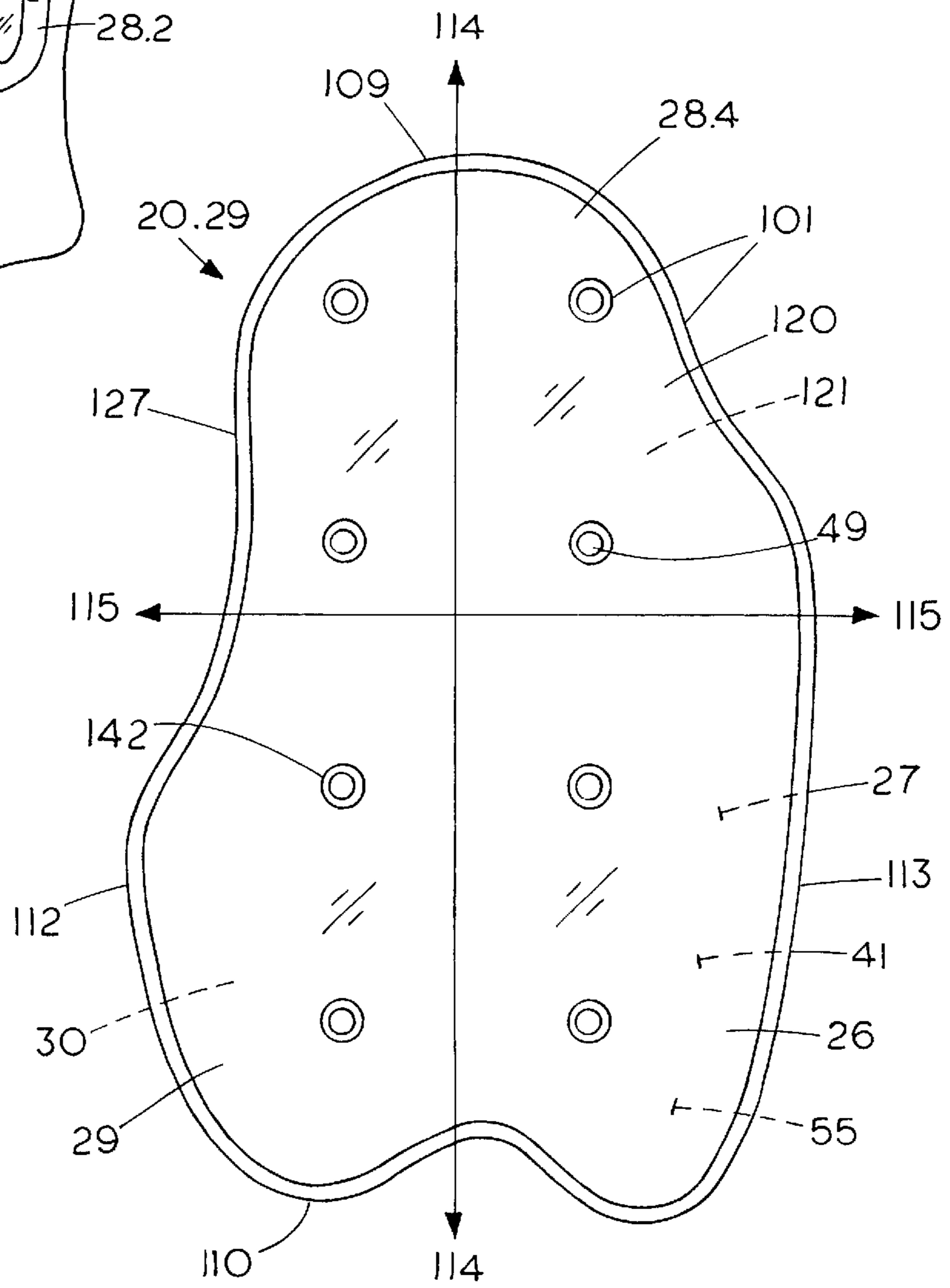

FIG. 56

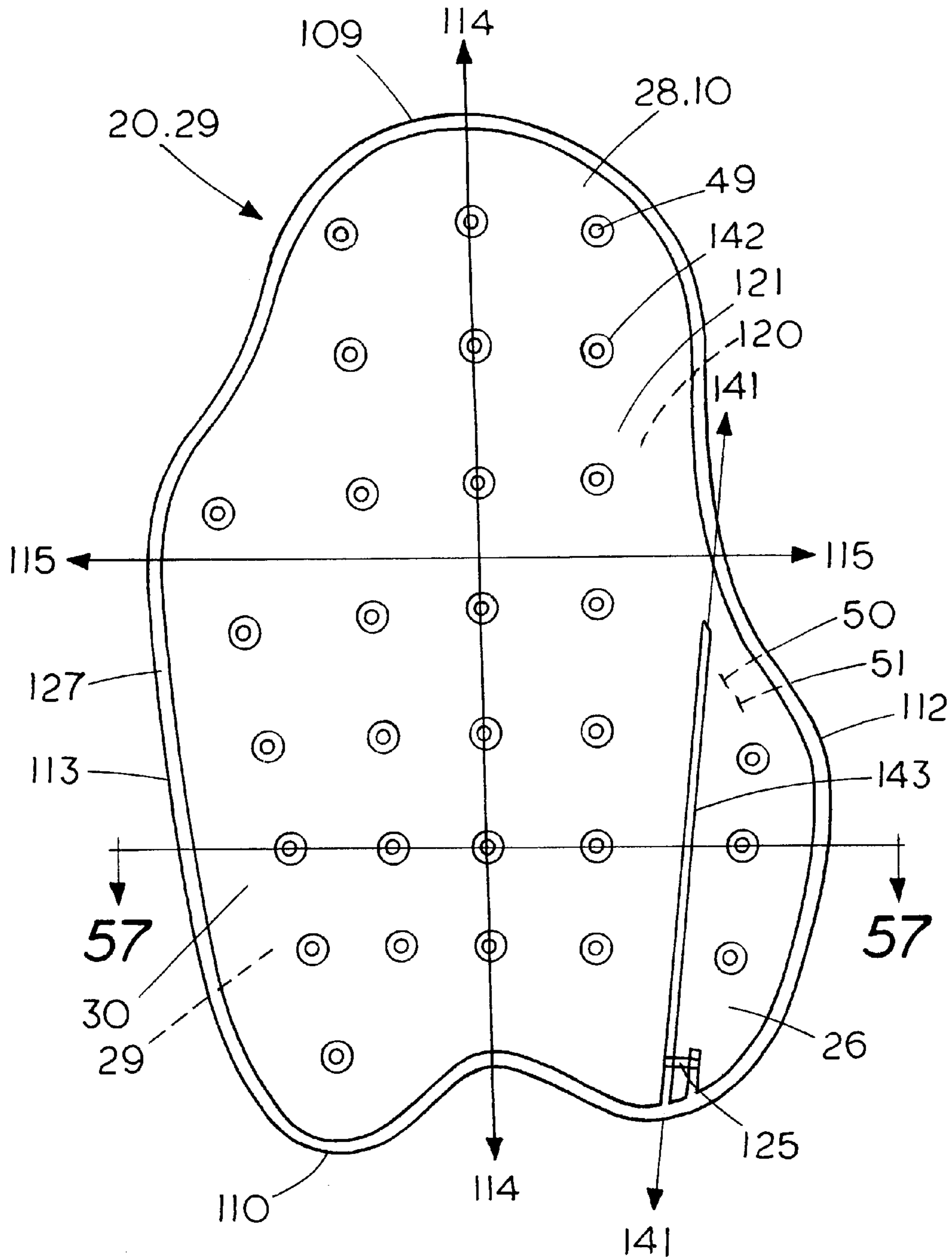

FIG. 57

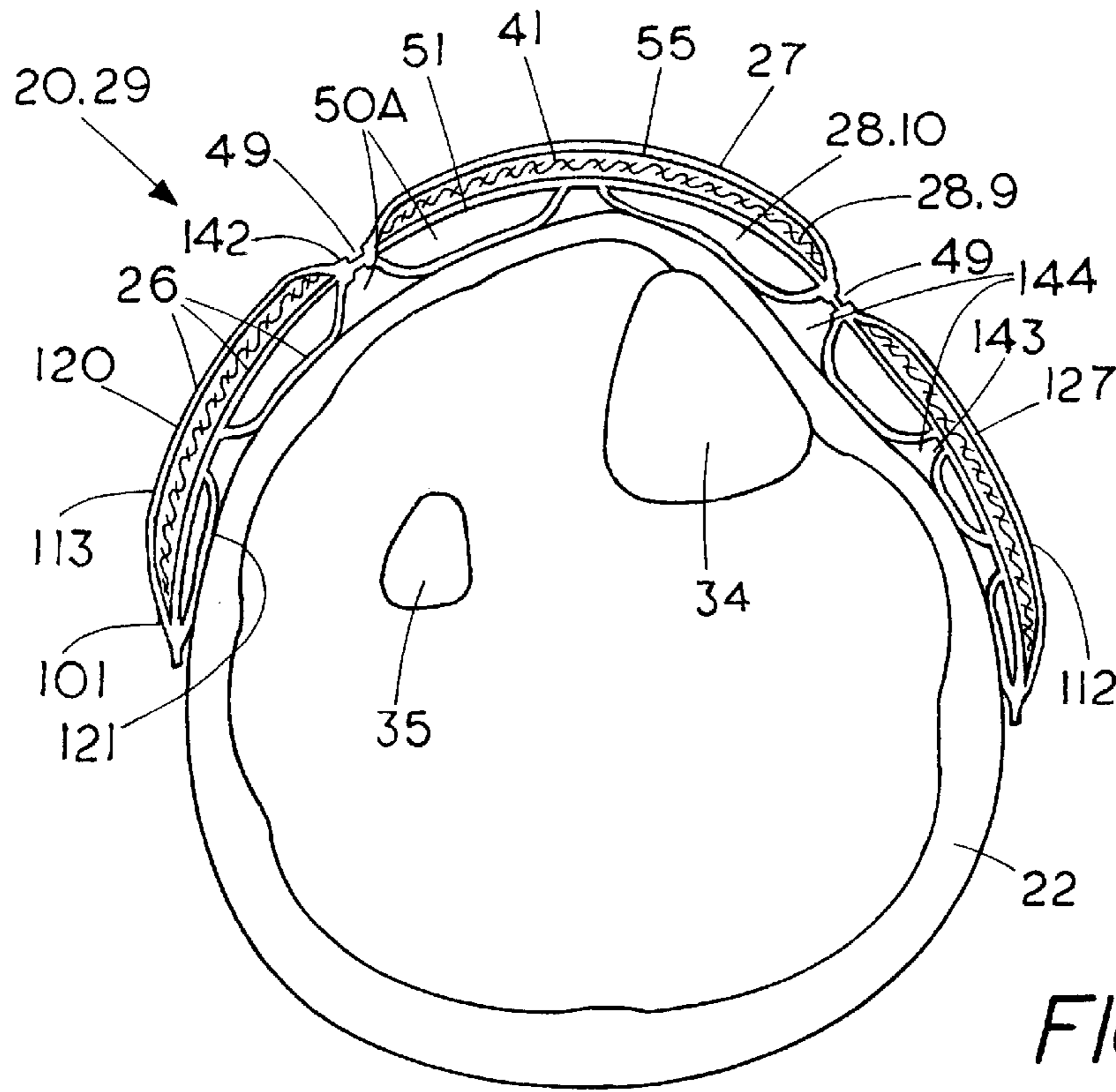

FIG. 58

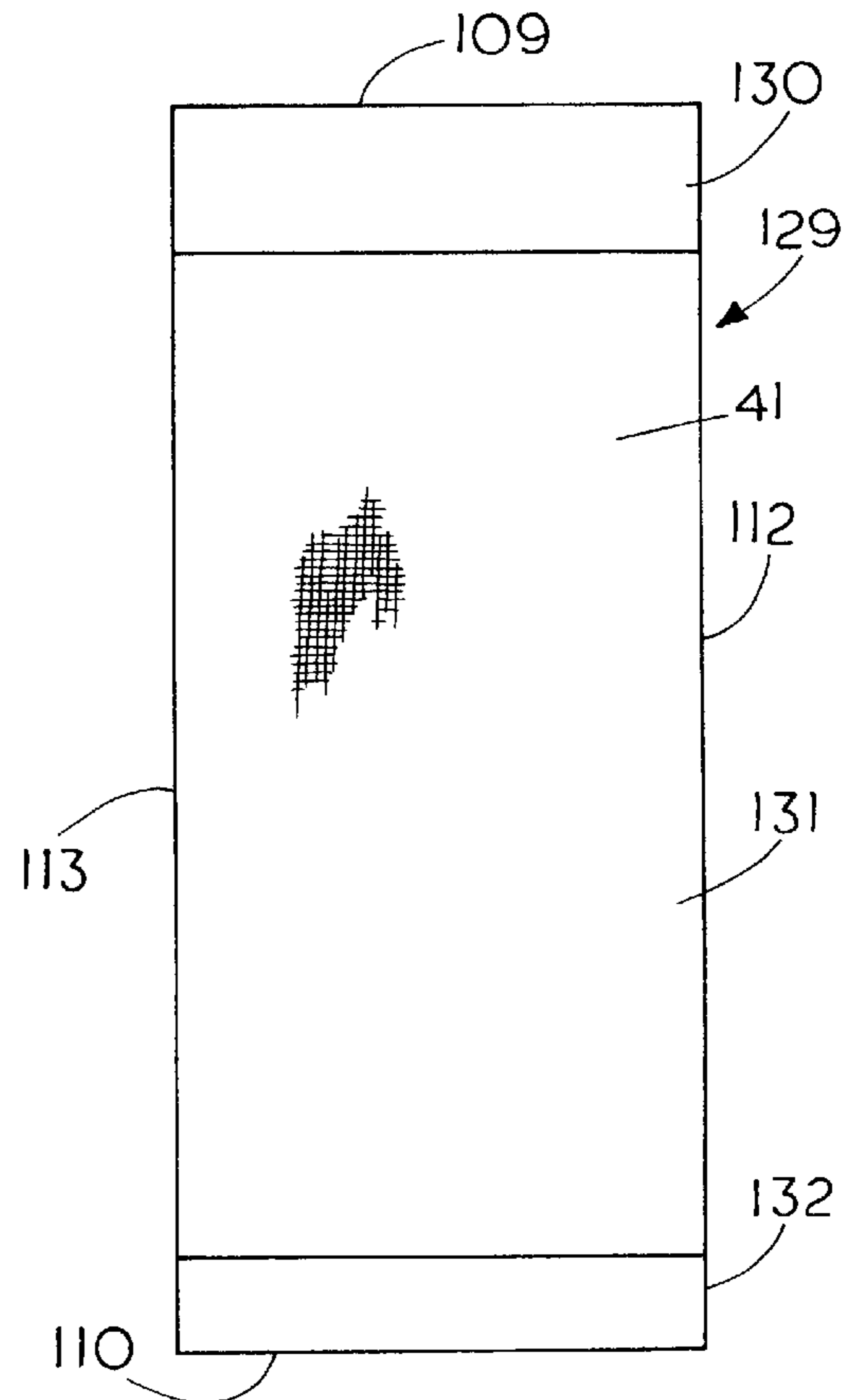

FIG. 59

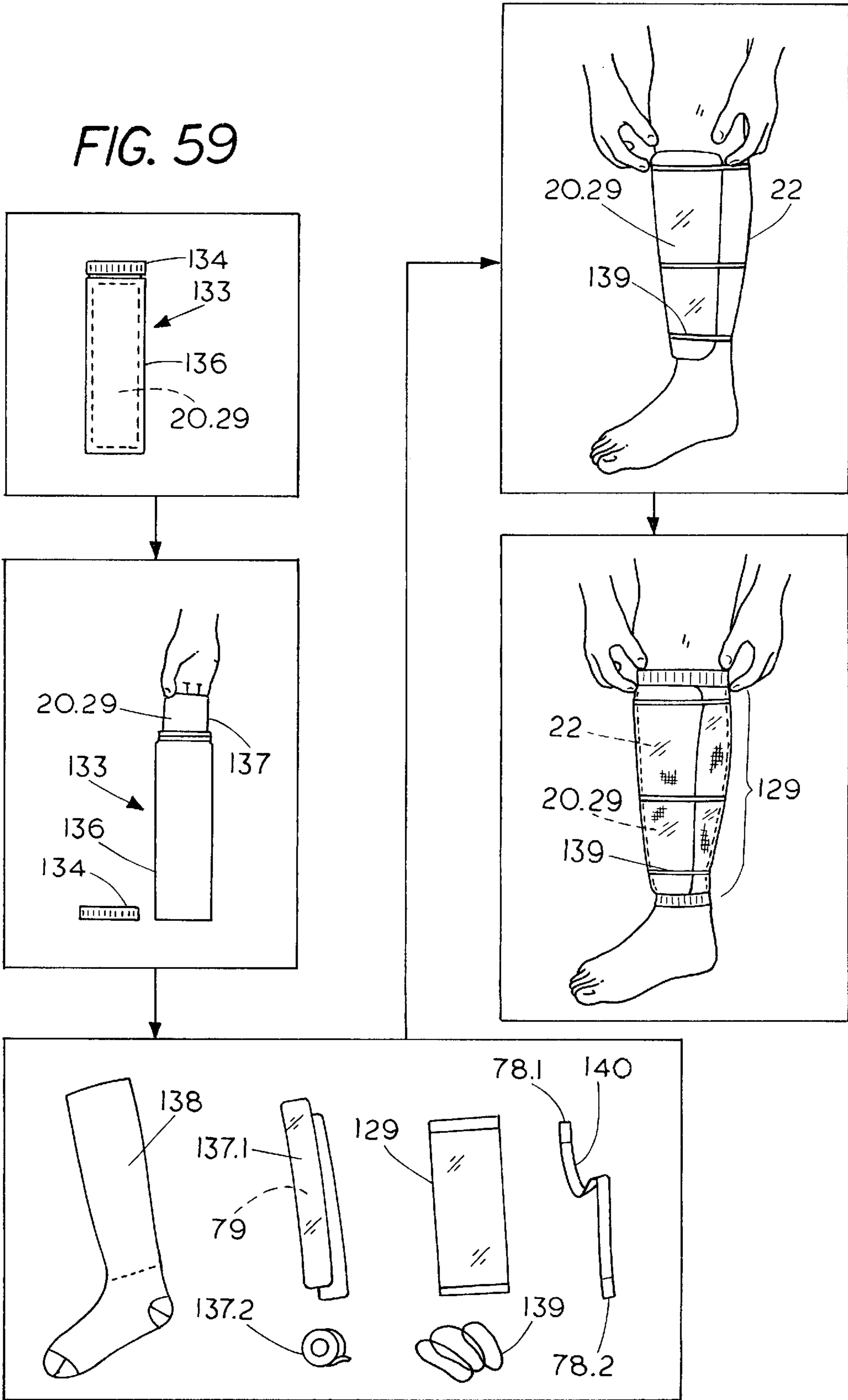
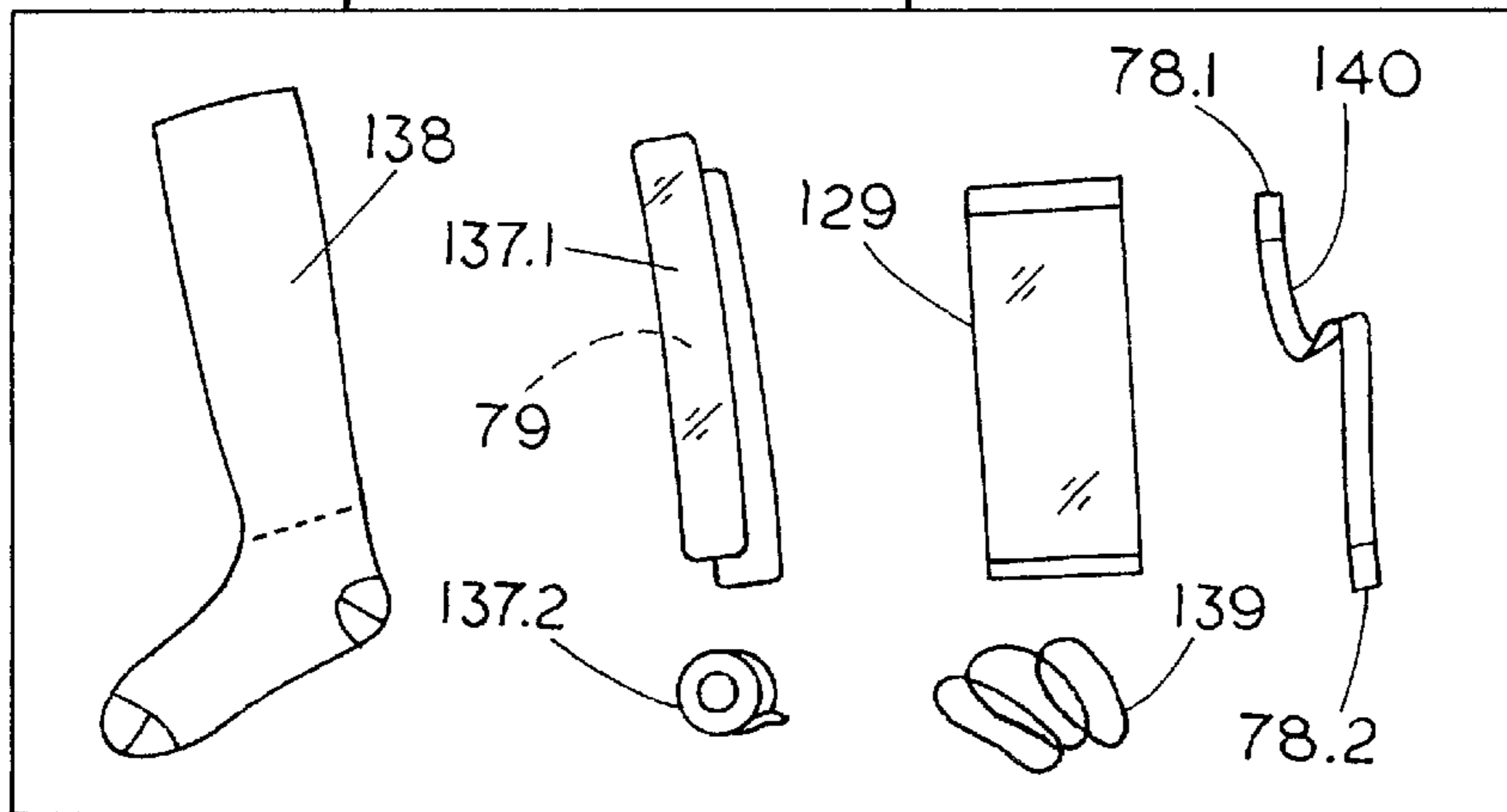
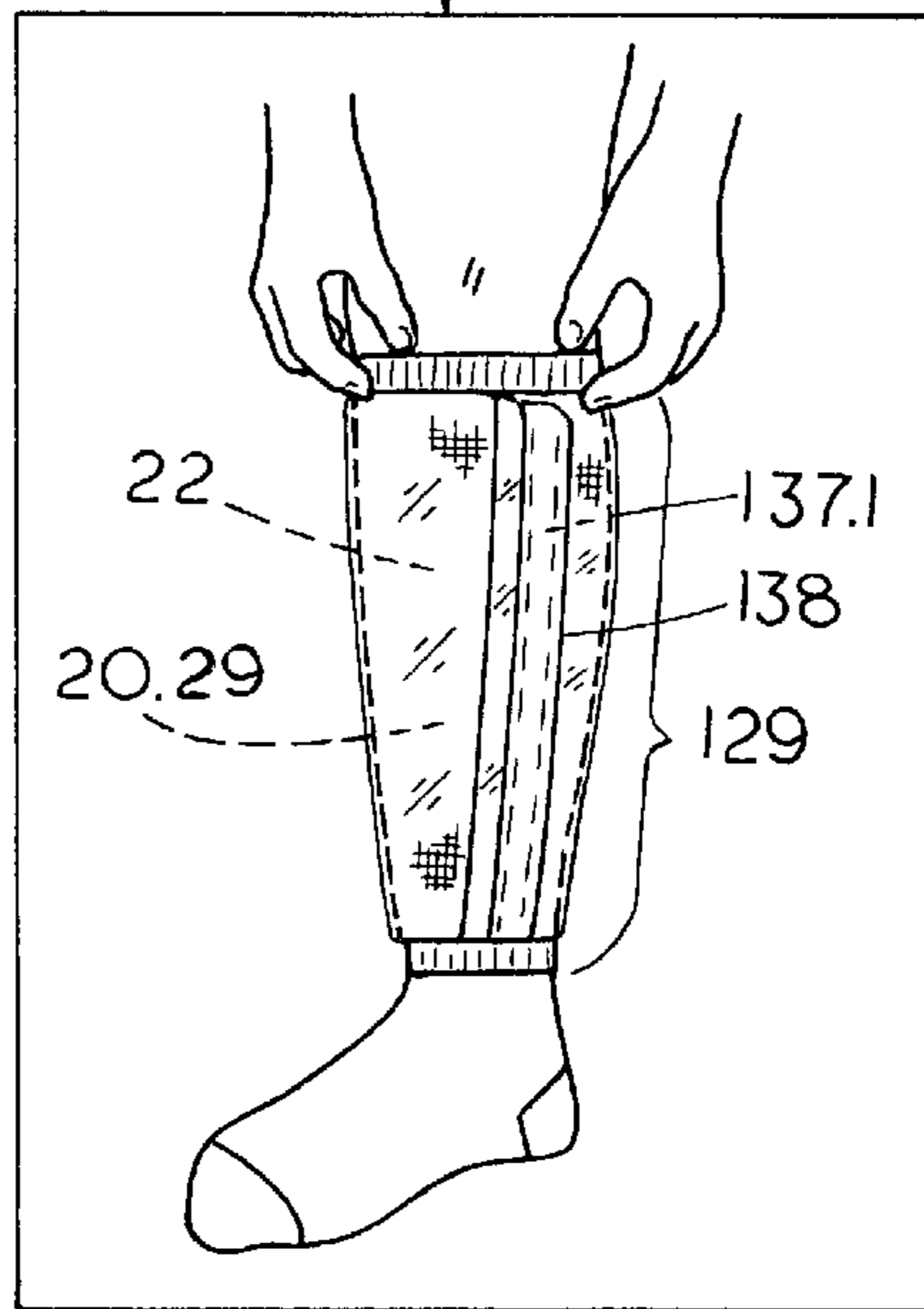
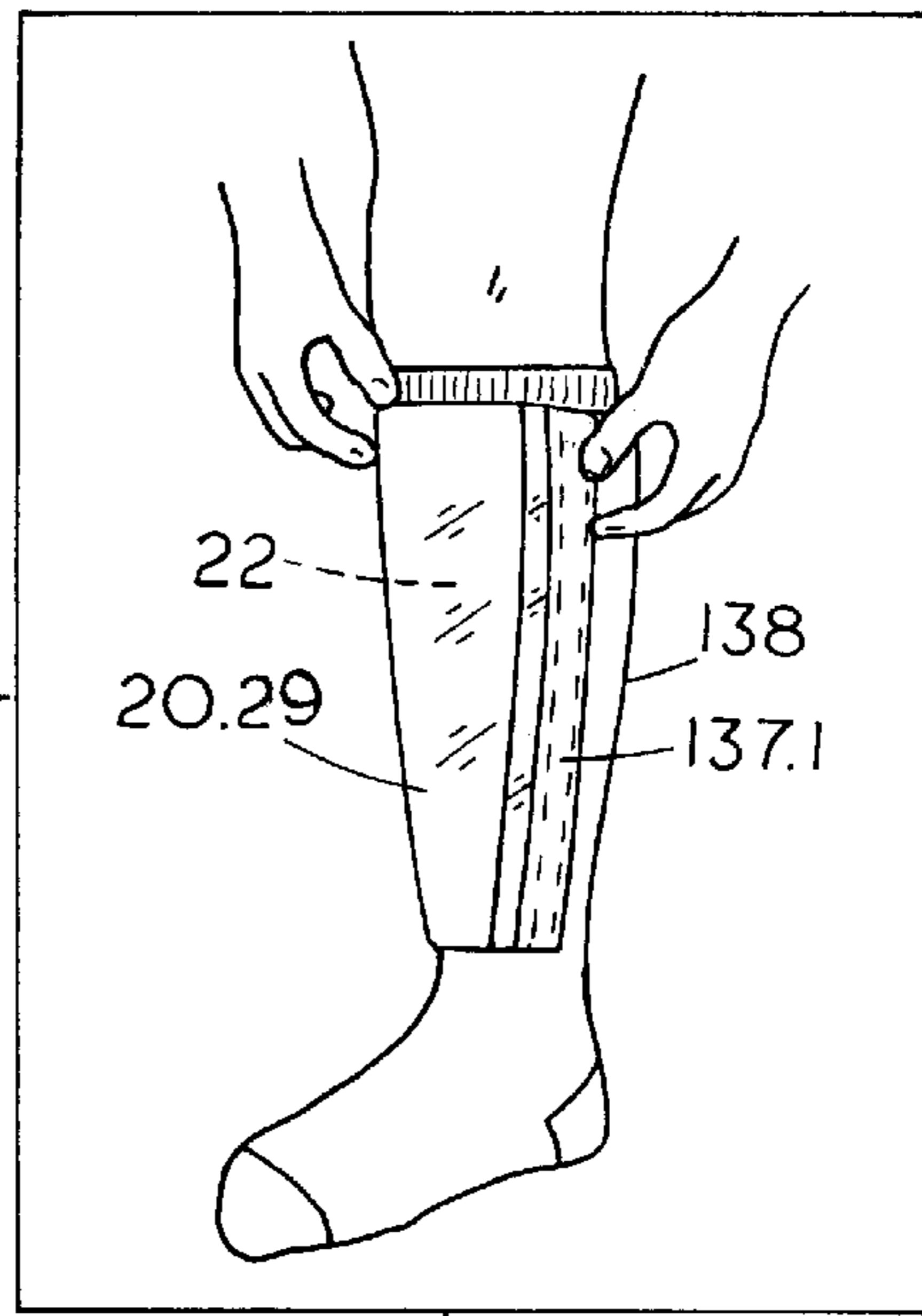
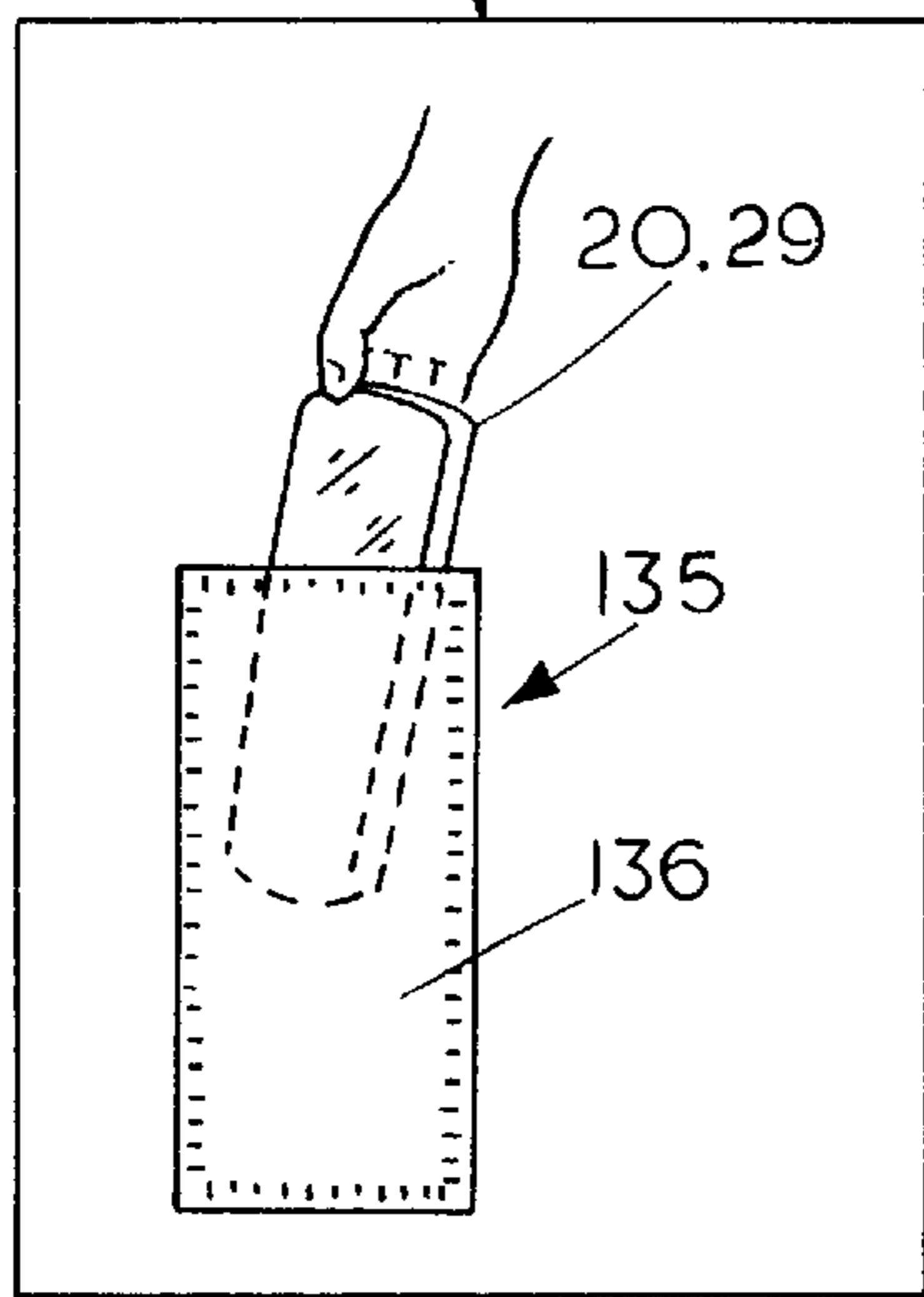
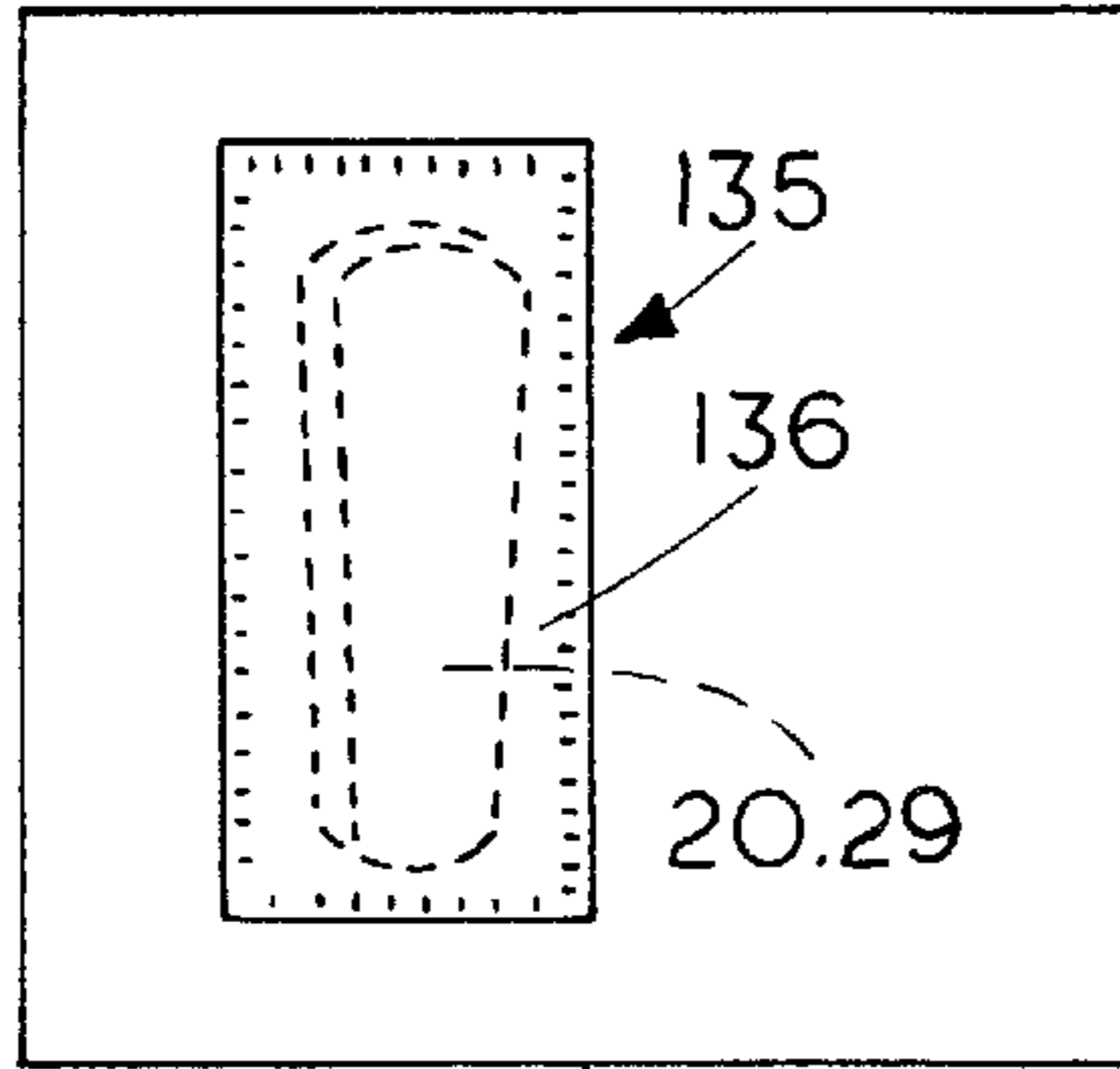



FIG. 60



## SHIN-GUARD, HELMET, AND ARTICLES OF PROTECTIVE EQUIPMENT INCLUDING LIGHT CURE MATERIAL

### RELATED U.S. APPLICATION DATA

This application is a continuation-in-part of U.S. patent application Ser. No. 09/523,851 filed on Mar. 13, 2000, now U.S. Pat. No. 6,490,730 and claims priority of application under 35 U.S.C. §120.

### FIELD OF THE INVENTION

The present invention relates to the field of apparel, and in particular, to shin-guards, pads, helmets, prosthetics, and other articles of protective equipment.

### BACKGROUND OF THE INVENTION

The use of shin-guards, knee pads, thigh pads, hip pads, rib guards, shoulder pads, elbow pads, biceps pads, forearm pads, gloves, neck guards, face guards, chin straps and guards, wrist guards, braces, and helmets is prevalent in a large number of contact and non-contact sports including soccer, football, hockey, baseball, volleyball, and in-line skating. Protective knee pads and helmets also enjoy wide-spread use in the construction industry, military, and in the field of transportation including bicycle, motorcycle, and sports automobile operation. Prosthetic devices such as back supports and wrist guards which include conforming shields or pads are also widely used.

Many articles of athletic and protective equipment include a hard outer shell made of leather, natural or synthetic rubber, glass or carbon fiber composites, thermoplastics, metal, and the like. Often, such articles will include a relatively soft inner liner of padding material which is made, e.g., of cotton, wool, natural or synthetic rubber, thermoplastic material, foam material, gas filled bladders, flowable solids or liquids, bladders including a moldable and curable material, or various textile materials. Most of these articles of protective equipment have relied upon the incorporation of generic norms or average shapes with regards to those surfaces contacting the anatomy in order to provide limited accommodation to the unique anatomical features and characteristics of an individual wearer. However, pre-formed structures of various kinds imperfectly accommodate a greater or lesser number of individuals depending upon the incorporation of characteristic norms in their design and fabrication. As every individual has different anatomical features and characteristics, a pre-formed structure will not accommodate every individual to the same degree.

Moreover, recent research has revealed that soccer players are at risk of chronic traumatic brain injury due to repeated heading of the soccer ball. The cumulative trauma has a degenerative effect similar to that which has been observed in boxers. It should be recognized that a soccer ball can travel at approximately 60 miles per hour and impact the head with a force of 175 pounds. The following studies have documented this phenomenon:

J. T. Maser et al., "Chronic Traumatic Brain Injury In Professional Soccer Players," *Neurology*, 1998, September; 51(3): pages 791-796.

A. T. Tysvaer et al., "Head and Neck Injuries Among Norwegian Soccer Players. A Neurological, Electroencephalographic, Radiologic and Neuropsychological Evaluation," *Tidsskr Nor Laegeforen*, 1992, April, 10;112(10): pages 1268-1271.

A. T. Tysvaer, "Head and Neck Injuries In Soccer. Impact of Minor Trauma," *Sports Medicine*, 1992, September; 14(3): pages 200-213.

A. T. Tysvaer et al., "Soccer Injuries to the Brain. A Neuropsychological Study of Former Soccer Players," *American Journal of Sports Medicine*, 1991, January-February; 19(1): pages 56-60.

5 A. T. Tysvaer et al., "Soccer Injuries to the Brain. A Neurologic and Electroencephalographic Study of Active Football Players." *American Journal of Sports Medicine*, 1989, July-August; 17(4): pages 573-578.

O. Sortland, et al., "Brain Damage in Former Association Football Players. An Evaluation by cerebral Computed Tomography," *Neuroradiology*, 1989; 31(1): pages 44-48.

10 B. P. Boden, et al., "Concussion Incidence in Elite College Soccer Players," *American Journal of Sports Medicine*, 1998, March-April; 26(2): pages 238-241.

15 There is then a need for a novel protective helmet for use in soccer which will at least partially attenuate the impact that takes place when a soccer ball is headed. Further, it can be readily understood that it would be advantageous that such a helmet closely conform to the anatomical features of the wearer's head and permit control of the soccer ball while heading.

20 There have been attempts to made custom molded articles of protective equipment having a permanent memory capability, in particular, U.S. Pat. Nos. 5,454,780, 5,456,658, 5,480,376, 5,544,663, D381,131, D394,110, D394,112, D394,905, 5,637,077, 5,732,713, 5,755,678, 5,842,475, 5,868,693, 6,065,152, 6,126,626, 6,128,777, 6,131,195, 6,134,720, 6,152,892, 6,178,556, 6,226,795, D445,221, and U.S. Pat. No. 6,269,485 assigned to Parker Medical Associates LLC and/or Parker Athletic Products, LLC of Charlotte, N. C., all of these patents hereby being incorporated by reference herein.

25 U.S. Pat. No. 4,292,263 granted to James Hanrahan, et al. is directed to the making of protective padding. U.S. Pat. No. 6,065,152 assigned to Adidas, and also DE 3011566 A1 and DE 4403390 A1 assigned to Karl Uhl GmbH, are directed to making shin guards, and all of these patents are hereby incorporated by reference herein. Further, there are numerous patents directed towards the making of casts or braces held by 3M, that is, Minnesota Mining and Manufacturing Company of St. Paul, Minn., e.g., U.S. Pat. Nos. 4,667,661, 4,683,877, 4,774,937, 4,856,502, 4,888,225, 4,946,726, 5,002,047, and 5,042,464.

30 In addition, the present inventor's U.S. Pat. Nos. 4,674,206, 5,101,580, 5,203,793, and in particular, U.S. Pat. No. 5,632,057, include teachings relating to the customization of footwear components, all of these patents hereby being incorporated by reference herein. The present application is a Continuation-In-Part of Ser. No. 09/523,851 filed on Mar. 13, 2000, which was a Continuation-In-Part of Ser. No. 08/862,598 filed on May 23, 1997, which was a Continuation of U.S. Pat. No. 5,632,057 which was granted on May 17, 1997. It was anticipated in the applicant's U.S. Pat. No. 5,632,057, column 37, lines 33-46, that the teachings contained therein with respect to the use of light-cure materials could be applied to the general subject matter of the present application. U.S. Pat. No. 3,905,376, granted to Amos Johnson et al., hereby incorporated by reference herein, teaches various custom prosthetic devices including light cure material having permanent memory. U.S. Pat. No. 4,512,340, granted to Carl Buck, hereby incorporated by reference herein, teaches the use of light cure materials in making casts.

35 40 45 50 55 60 65 The procedures and methods associated with many previous attempts to make custom molded articles of protective equipment having a permanent memory capability have

been relatively complex, time consuming, expensive, or otherwise not amenable to mass production and use by the general public. Accordingly, it is an object of the present invention to provide a fast, easy, effective and inexpensive method of making custom molded articles of protective equipment having a permanent memory capability.

#### SUMMARY OF THE INVENTION

The present invention teaches novel articles of protective equipment including light cure material. The present invention can provide a fast, easy, inexpensive method of making custom molded articles of protective equipment having a permanent memory capability. Accordingly, the present invention can be used to make protective athletic equipment such as guards, pads, helmets, body armor, and prosthetic devices.

An article of protective equipment according to the present invention such as a guard, a pad, or a helmet for protecting a portion of a wearer's anatomy can comprise a superior side, inferior side, medial side, lateral side, anterior side, and posterior side, comprising a bladder containing a textile material impregnated with a light cure material which can be caused to set and cure when exposed to light having a wavelength in the range between 280–780 nanometers.

The light cure material can comprise a polyurethane material. Alternately, the light cure material can comprise an epoxy material. The light cure material can be contained in a bladder to prevent oxygen inhibition of the curing process. The light cure material can be caused to cure using visible light and/or ultraviolet light.

The bladder can be made of a thermoplastic film. Alternately, the bladder can be made in part by a thermoplastic film comprising the outer layer of the bladder which can be affixed to a foam material. The thermoplastic film can be substantially transparent. The thermoplastic film can comprise polyurethane.

The textile material can be made of a woven or non-woven material. The textile material can be made of fiberglass. The textile material can be substantially inelastic. Alternately, the textile material can be stretchable and elastic. Alternately, a textile material can comprise at least a portion of the outer surface of a shin-guard.

The article of protective equipment such as a shin-guard can include a foam material. The foam material can comprise ethylene vinyl acetate. The foam material can comprise peaks and valleys. The foam material can be used externally with respect to the bladder. Alternately, the foam material can be impregnated with the light cure material and be contained within the bladder.

The article of protective equipment such as a shin-guard can include a fluid filled bladder. The fluid filled bladder can include a void containing a gas. The gas can comprise a mixture of gases. The gas can be pressurized at atmospheric pressure. Alternately, the gas can be pressurized above atmospheric pressure.

The article of protective equipment such as a shin-guard can include a bladder which is affixed in functional relation to a foam material, and the bladder can substantially comprise the anterior side and the foam material can substantially comprise the posterior side of the article of protective equipment such as a shin-guard.

The article of protective equipment such as a shin-guard can comprise an anterior bladder and a posterior bladder configured in an overlapping relationship.

The article of protective equipment such as a shin-guard can comprise at least two bladders configured in a side-by-side relationship.

The article of protective equipment such as a shin-guard can comprise a reflective material.

The article of protective equipment such as a shin-guard can comprise a plurality of openings for ventilation.

The article of protective equipment such as a shin-guard can comprise channels for ventilation.

An article of protective equipment such as a shin-guard for protecting a portion of a wearer's anatomy can comprise a superior side, inferior side, medial side, lateral side, anterior side, and posterior side, comprising three layers of plastic film affixed together in functional relation thereby forming an anterior bladder and a posterior bladder, and the anterior bladder can include a textile material impregnated with a light cure material which can be caused to set and cure when exposed to light having a wavelength in the range between 280–780 nanometers, and the posterior bladder can include a void comprising a gas.

In particular, the present invention teaches a shin-guard for protecting a portion of a wearer's anatomy comprising a superior side, inferior side, medial side, lateral side, anterior side, and posterior side, comprising a bladder containing a textile material impregnated with a light cure material which can be caused to set and cure when exposed to light having a wavelength in the range between 280–780 nanometers.

The shin-guard can comprise an asymmetrical shape as between the medial side and the lateral side.

The shin-guard can comprise a superior guard portion for protecting a wearer's lower leg including a first strap near the superior side for affixing about the wearer's lower leg, and an inferior guard portion for protecting the wearer's medial and lateral malleoli including a second strap for affixing under the plantar side of the wearer's foot.

The shin-guard can comprise a superior guard portion, and said inferior guard portion which are detachable.

The shin-guard can comprise a posterior guard for protecting a wearer's Achilles tendon.

The shin-guard can comprise one or more side guards for protecting a wearer's medial malleolus and lateral malleolus.

The shin-guard can comprise a flex notch on the medial side.

The shin-guard can comprise a first strap near the superior side, and a second strap near the inferior side.

The shin-guard can be secured upon a wearer with the use of a sock. Alternately, the shin-guard can be secured upon a wearer with the use a sleeve. Alternately, the shin-guard can be secured upon a wearer with the use of at least one strap. Alternately, the shin-guard can be inserted into the pocket of a pocket sock and donned on a wearer.

The present invention teaches a pad for protecting a portion of a wearer's anatomy comprising a bladder containing a light cure material which can be caused to set and cure when exposed to light having a wavelength in the range between 280–780 nanometers. The pad can be taken from the select group of pads consisting of shin-pads, knee pads, thigh pads, hip pads, rib guards, shoulder pads, elbow pads, forearm pads, biceps pads, neck pads, glove pads, chin strap pads, and back support pads. Alternately, a preferred pad can comprise an impregnated textile material.

The present invention teaches a preferred chin strap including a bladder containing light cure material. Alternately, a chin strap can comprise an impregnated textile material.

The present invention teaches a preferred back support including a bladder containing light cure material.

Alternately, a back support can comprise an impregnated textile material.

The present invention teaches a preferred wrist guard including a bladder containing light cure material. Alternately, a wrist guard can comprise an impregnated textile material.

The present invention teaches a preferred helmet liner comprising light cure material. The light cure material can be contained in a bladder comprising a thermoplastic film such as polyurethane. A foam material having peaks and valleys can be included within the bladder. The bladder can include a void containing a gas or mixture of gases. Alternately, the film comprising the outer layer of the bladder can be affixed to a foam material. Alternately, a helmet liner can include an inner bladder and an outer bladder configured in an overlapping relationship. Alternately, a helmet liner can include two bladders configured in a side-by-side relationship. Alternately, a helmet liner can include a textile material. The textile material can be stretchable and elastic. The textile material can be impregnated with a light cure material to comprise an impregnated textile material. The textile material can be contained in a bladder, or alternately, can comprise the inner surface or outer surface of a helmet liner. A helmet liner can include temporal and sphenoidal bladders for protecting the sides of the head proximate the temple and ear, an occipital bladder for protecting the back of the head, a parietal bladder for protecting the top of the head, and a frontal bladder for protecting the front of the head. Alternately, the parietal bladder and frontal bladder can both be made in two generally opposing bladders or chambers each protecting their respective medial or lateral aspect of the head. A helmet liner can be inserted and affixed to the outer shell of a helmet.

The present invention teaches a preferred helmet including light cure material. A helmet can comprise an outer shell and a helmet liner. A helmet can include a plurality of segments comprising at least a temporal and sphenoidal segment for protecting the sides of the head proximate the temple and ear, an occipital segment for protecting the back of the head, a parietal segment for protecting the top of the head, and a frontal segment for protecting the front of the head. The segments can include a light cure material therebetween. The helmet can comprise an outer surface which is textured, tactified, and includes raised grip elements, in partial or complete combination. A helmet can include a textile material. The textile material can be stretchable and elastic. The textile material can be impregnated with a light cure material to comprise an impregnated textile material. The impregnated textile material can be contained in a bladder, or alternately, can comprise the outer surface of a helmet. The helmet can include a thin layer of protective film.

A preferred method of making an article of protective equipment such as a guard, a pad, or a helmet comprising a light cure material can comprise the steps of:

- a) Opening a container which is substantially impenetrable to light and removing the article of protective equipment;
- b) Placing the article of protective equipment in position upon a wearer; and,
- c) Exposing the article of protective equipment to light causing the light-cure material to cure.

A preferred method of making a shin-guard having a superior side, inferior side, medial side, lateral side, anterior side, and posterior side, comprising a bladder containing a

textile material impregnated with a light cure material which can be caused to set and cure when exposed to light having a wavelength in the range between 280–780 nanometers can comprise the steps of:

- a) Opening a container which is substantially impenetrable to light and removing the shin-guard;
- b) Placing the shin-guard in position upon a wearer; and,
- c) Exposing the shin-guard to light causing the light cure material to cure.

#### BRIEF DESCRIPTION OF THE DRAWINGS

FIG. 1 is a perspective view of a shin guard including a bladder containing light cure material positioned on a wearer.

FIG. 2 is a perspective view of an alternate shin guard including a bladder containing light cure material positioned on a wearer.

FIG. 3 is a cross-sectional view of the lower left leg of a wearer, taken along the transverse axis.

FIG. 4 is a cross-sectional side view of a shin guard including two bladders configured in an overlapping relationship containing two light cure materials having different physical and mechanical properties.

FIG. 5 is a cross-sectional side view of a shin guard including a bladder containing a gas.

FIG. 6 is a front perspective view of a shin guard including two bladders configured in a side-by-side relationship containing two light cure materials having different physical and mechanical properties.

FIG. 7 is a side cross-sectional view of a shin guard including a bladder containing a light cure material that is affixed to a foam material.

FIG. 8 is a transverse cross-sectional view of a shin guard including a bladder containing light cure material and a foam material.

FIG. 9 is a transverse cross-sectional view of a shin guard including a bladder made from a substantially transparent film material affixed to a foam material, and containing a light cure material.

FIG. 10 is a front perspective view of a pocket sock made of textile material, with parts broken away, and including means for securing a shin guard.

FIG. 11 is a front view of a football player wearing a plurality of pads, with parts of his uniform broken away.

FIG. 12 is a perspective view of a chin-strap including a light cure material.

FIG. 13 is a perspective view of knee pad including a light cure material.

FIG. 14 is a top plan view of a forearm pad including a light cure material.

FIG. 15 is a top plan view of an elbow pad including a light cure material.

FIG. 16.1 is a perspective view of the bones of an infant skull.

FIG. 16.2 is a perspective view of the bones of an adult skull.

FIG. 17 is a perspective view of helmet liner including a light cure material, with parts broken away, positioned upon a wearer.

FIG. 18 is a bottom perspective view of a helmet liner secured in function relation to a helmet.

FIG. 19 is a perspective view of a helmet, with parts broken away, positioned on a wearer.

FIG. 20 is a perspective view of a helmet having a plurality of segments including light cure material therebetween, with parts broken away, positioned on a wearer.

FIG. 21 is perspective view of a helmet including a plurality of segments that are substantially encapsulated by a light cure material, with parts broken away.

FIG. 22 is a perspective view of a back support including light cure material.

FIG. 23 is a perspective view of a wrist guard including light cure material positioned on a wearer.

FIG. 24 is a perspective view of a shin guard including a bladder containing an impregnated textile material, with parts broken away, positioned on a wearer.

FIG. 25 is a perspective view of shin guard including an impregnated textile material positioned on a wearer.

FIG. 26 is a perspective view of a helmet including a bladder containing an impregnated textile material, with parts broken away, positioned on a wearer.

FIG. 27 is a perspective view of helmet including an impregnated textile material, positioned on a wearer.

FIG. 28 is an anterior plan view of a shin guard having a symmetrical shape in which both the strap for passing under a wearer's foot, and also the stretchable guard for encompassing a wearer's lower leg and ankles have been cut so that the shin guard can be flattened out and shown with greater accuracy.

FIG. 29 is an anterior plan view of a shin guard having an asymmetrical shape in which both the strap for passing under a wearer's foot, and also the stretchable guard for encompassing a wearer's lower leg and ankles have been cut so that the shin guard can be flattened out and shown with greater accuracy.

FIG. 30 is an anterior plan view of a shin guard similar to that shown in FIG. 29 having an asymmetrical shape in which both the strap for passing under a wearer's foot, and also the stretchable guard for encompassing a wearer's lower leg and ankles have been cut so that the shin guard can be flattened out and shown with greater accuracy, and also including openings for ventilation.

FIG. 31 is an anterior plan view of a shin guard similar to that shown in FIG. 30 having an asymmetrical shape and including openings for ventilation in which the strap for passing under a wearer's foot has been cut so that the shin guard can be flattened out and shown with greater accuracy, but excluding the stretchable guard for encompassing a wearer's lower leg and ankles.

FIG. 32 is an anterior plan view of a shin guard similar to that shown in FIG. 30 having an asymmetrical shape and including openings for ventilation in which both the strap for passing under a wearer's foot, and also the stretchable guard for encompassing a wearer's lower leg and ankles have been cut so that the shin guard can be flattened out and shown with greater accuracy, but also including a flex notch on the medial side.

FIG. 33 is an anterior plan view of a shin guard generally similar to that shown in FIG. 30 having an asymmetrical shape and including openings for ventilation in which both the strap for passing under a wearer's foot, and also the stretchable guard for encompassing a wearer's lower leg and ankles have been cut so that the shin guard can be flattened out and shown with greater accuracy, but the pocket extends more inferiorly about the areas corresponding to the medial and lateral malleoli of a wearer.

FIG. 34 is an anterior plan view of a shin guard generally similar to that shown in FIG. 30 having an asymmetrical

shape and including openings for ventilation in which both the strap for passing under a wearer's foot, and also the stretchable guard for encompassing a wearer's lower leg and ankles have been cut so that the shin guard can be flattened out and shown with greater accuracy, but the stretchable guard portion extends further upwards about an area corresponding to a wearer's lower leg.

FIG. 35 is a posterior three dimensional perspective view of a shin guard generally similar to that shown in FIG. 34 showing a stretchable guard portion, but also a posterior guard.

FIG. 36 is a posterior three dimensional perspective view of a shin guard generally similar to that shown in FIG. 35 showing a stretchable guard portion, but also a posterior guard having a pocket for receiving a bladder including light cure material.

FIG. 37 is an anterior plan view of a bladder for containing light cure material for use with a shin guard having an asymmetrical shape generally similar to that shown in FIG. 30.

FIG. 38 is an anterior plan view of a textile material for possible use inside the bladder shown in FIG. 37.

FIG. 39 is an anterior plan view of a bladder generally similar to that shown in FIG. 37 including the textile material shown in FIG. 38 therein.

FIG. 40 is an anterior plan view of a foam material for possible use within a bladder similar to that shown in FIG. 37 or FIG. 39.

FIG. 41 is an anterior plan view of a foam material for possible exterior use in combination with a bladder similar to that shown in FIG. 37 or FIG. 39.

FIG. 42 is an anterior plan view of a reflective material for possible interior or external use in combination with a bladder similar to that shown in FIG. 37 or FIG. 39.

FIG. 43 is an anterior plan view of a reflective material generally similar to that shown in FIG. 42 for possible interior or external use in combination with a bladder similar to that shown in FIG. 37 or FIG. 39, but also having openings for ventilation.

FIG. 44 is an anterior plan view of a shin guard with parts broken away to show the use of a foam material posterior of a bladder containing light cure material that is located within a pocket of the shin guard.

FIG. 45 is an anterior plan view of a shin guard with parts broken away to show the use of a foam material inside of a bladder containing light cure material that is located within a pocket of the shin guard.

FIG. 46 is an anterior plan view of a fluid filled bladder for use with a shin guard generally similar to that shown in FIG. 30 or FIG. 31.

FIG. 47 is an anterior plan view of a shin guard with parts broken away to show the use of a fluid filled bladder posterior of a bladder containing light cure material that is located within a pocket of the shin guard.

FIG. 48 is an anterior plan view of a shin guard with parts broken away to show the use of a fluid filled bladder inside of a bladder containing light cure material that is located within a pocket of the shin guard.

FIG. 49 is an anterior plan view of a shin guard including straps and having an asymmetrical shape near both the superior side and the inferior side as between the medial side and lateral side.

FIG. 50 is an anterior plan view of a shin guard generally similar to that shown in FIG. 49 having an asymmetrical

shape near both the superior side and the inferior side as between the medial side and lateral side, but not including straps.

FIG. 51 is an exploded anterior plan view of a shin guard having a superior guard portion generally similar to that shown in FIG. 31, but including an inferior guard portion which can be selectively removed and replaced.

FIG. 52 is an anterior plan view of a shin guard having an asymmetrical shape near both the superior side and the inferior side as between the medial side and lateral side that does not include straps.

FIG. 53 is a cross-sectional and exploded view of one possible embodiment of the shin guard shown in FIG. 52.

FIG. 54 is a perspective medial side view of a shin guard on a wearer showing the use of several bladders containing different light cure materials.

FIG. 55 is an anterior plan view of a shin guard including a fluid filled bladder on the posterior side and having an asymmetrical shape near both the superior side and the inferior side as between the medial side and lateral side.

FIG. 56 is a posterior plan view of the shin guard including a fluid filled bladder shown in FIG. 55.

FIG. 57 is a transverse cross-sectional view of the shin guard including a fluid filled bladder shown in FIGS. 55 and 56, taken along line 57—57, and shown in position on a wearer's lower leg.

FIG. 58 is an anterior plan view of a sleeve for possible use with embodiments of a shin guard which do not include strap fastening means such as those shown in FIG. 50 and FIG. 52.

FIG. 59 is a flow diagram that shows at least one method of making a custom fit shin guard upon a wearer.

FIG. 60 is another flow diagram that shows at least one method of making a custom fit shin guard upon a wearer.

#### DETAILED DESCRIPTION OF THE PREFERRED EMBODIMENTS

The present invention teaches novel articles of apparel and protective equipment including light cure materials having a permanent memory capability. The resulting articles can protect a wearer from impact events and possible injury. Accordingly, the present invention can be used to make protective equipment including but not limited to shin-guards, knee pads, elbow pads, helmets, and prosthetic devices.

FIG. 1 is a perspective view of a preferred shin guard 20.1 including a light cure material 27 positioned on the lower leg 22 of a wearer 21. Shin guard 20.1 can be made of a thermoplastic material such as a thin flexible plastic film 26 which is sealed about any mating edges so as to create a bladder 28. The preferred film 26 for a bladder 28 can be made of polyurethane and can range in thickness between 5–50 mils, depending upon the particular application. Suitable polyurethane films include MP 1880 AE and MP 1890 AE having a thickness of 0.02 inches and having a Shore A hardness of 80–90, which are made by Deerfield Urethane, Inc. of Deerfield, Mass., but other materials can be suitable for use including those taught in the patents assigned to Nike, Inc. which have been recited and incorporated by reference later in this specification. The film 26 can be sealed by radio frequency welding, heat and pressure welding, adhesive, and the like. The outer layer 29 of the bladder 28 faces generally opposite the inner layer 30 of the bladder 28, the former being more distant and the latter being closest to the wearer's body. Preferably, at least the outer layer 29 of

the bladder 28 is made of a substantially transparent film 26 that permits the transmission of light therethrough. A light-cure material 27 in a substantially liquid or viscous state is contained within bladder 28. The shin-guard 27 can be contained in a closed container for storage or shipping such as a jar, box, bag, package or sealed pouch, and the like, that does not substantially permit the transmission of ultraviolet and visible light. Such a container can be said to be substantially impermeable or impenetrable to ultraviolet and visible light. A package or sealed pouch including a thin plastic film including metallic foil can be advantageous for use. When shin-guard 20.1 is removed from a closed container or package and donned by a wearer 21, exposure of the shin guard 20.1 to a visible or ultraviolet light source such as sunlight, or a suitable man-made light source will cause the light cure material 27 contained within the bladder 28 to cure and form substantially solid matter.

Light is herein defined as electromagnetic radiation having a wavelength between 280 and 780 nanometers, thus includes a substantial portion of the ultraviolet and visible light spectrum. It can be advantageous to use natural sunlight or artificial visible light having a wavelength between 400 and 780 nanometers, since it is possible for exposure to artificial ultraviolet light to cause injury to skin and eye tissue.

One manufacturer of visible light photoinitiators, and in particular, of a blue light photoinitiator known as H-NU 470, is Spectra Group Limited of Maumee, Ohio. Another manufacturer of visible light photoinitiators is Ciba Specialty Chemicals of Tarrytown, N. Y. The preferred Ciba visible light photoinitiators include IRGACURE®184, and in particular, IRGACURE®784. Suitable Ciba ultraviolet light photoinitiators include IRGACURE®369, and 819.

Suitable man-made or artificial light sources for curing include, but are not limited to fluorescent lamps. When a natural light photoinitiator which is especially sensitive to the blue portion of the light spectrum such as H-NU 470 made by Spectra Group Limited of Maumee, Ohio, or alternately, IRGACURE®784 made by Ciba Specialty Chemicals of Tarrytown, N. Y. is used to trigger the light cure reaction, fluorescent lamps having substantial power in the blue portion of the visible light spectrum can be advantageous for use, such as "Daylight/6500K," "Colortone 50/5000K," "Colortone 75/7500K," those identified as "Actinic" or "SuperActinic," and in particular, "Special Blue," made by the Phillips Lighting Company of Somerset, N.J. Similar florescent lamps are also made by General Electric, Westinghouse, and Osram/Sylvania. In particular, a preferred fluorescent lamp for use having exceptional brightness and sufficient spectral power in the blue portion of the light spectrum is General Electric's BIAx®F40/30BX/SPX50, and the like.

Suitable light cure materials having a wide range of physical and mechanical characteristics are made, e.g., by Dow Corning Corporation of Midland, Mich., UVEX, Inc. of Sunnyvale, Calif., Sartomer, Inc. of Exton, Pa., 3M Minnesota Mining Company of St. Paul, Minn., Loctite Corporation of Rocky Hill, Conn., and Borden, Inc. of Columbus, Ohio. For example, Q3-6696 made by Dow Corning Corporation, or 3584 made by Loctite Corporation, and the like, can be suitable for use as a relatively soft, flexible, and shock absorbing light cure material, whereas 3102 or 3106 made by Loctite Corporation can be suitable for use as relatively rigid and non-flexible light cure material. Another major manufacturer of light cure materials known by the EBERCRYL® trademark is UCB Radcure of Smyrna, Ga. A ultraviolet light cure polyester resin and also

a light cure epoxy known by the trade name SOLAREZ that are made by Wahoo International, in Oceanside, Calif. can be used to make a relatively rigid light cure material. When used alone, this polyester resin is relatively brittle when flexed, but when it is used to impregnate a textile material such as fiberglass, the resulting product is relatively robust. The preferred light cure materials for use are made by San Rafael Coating of 700 Hawthorne Street, #A, Glendale, Calif. In particular, a material made of an acrylated urethane and monomer blend known as SRC A-3, and another material made of an acrylic oligomer and monomer blend epoxy known as SRC A-8 have been developed for use with the present invention.

FIG. 2 is a perspective view of an alternate preferred shin guard 20.2 including a light cure material 27 positioned on the lower leg 22 of a wearer 21. Alternate shin guard 20.2 can include a posterior guard 31 for protecting a portion of the Achilles tendon 23, and/or side guards 33 for protecting the malleoli 24. As shown in FIG. 2, shin guard 20.2 can include separate chambers, such as chambers 100.1, 100.2, and 100.3, connected by passages 103 which can be sealed off by welds 101, as desired. Alternately, shin guard 20.2 including posterior guard 31 and side guard(s) 33 can consist of completely separate bladders.

FIG. 3 is a cross-sectional view taken along the transverse plane of a wearer's left lower leg 22 adapted from *Atlas of Human Anatomy*, by Frank H. Netter, M. D., 1989, plate 491, showing the asymmetrical shape of the lower leg 22. Also shown is the location of the tibia 34, fibula 35, and a plurality of muscles 32 of the lower leg 22. A preferred shin guard 20 can provide protection for the tibia 34, in particular along the vulnerable anterior edge 36 and medial edge 37, and to the anterior muscles 95 of the lower leg 22.

FIG. 4 is a cross-sectional side view of an alternate shin guard 20.3 including a first light cure material 27.1 contained in outer bladder 28.1, and a second light cure material 27.2 having different physical and mechanical properties contained in inner bladder 28.2. The bladders are configured in an overlapping relationship. Light cure material 27.1 contained in outer bladder 28.1 can form a relatively rigid material, and light cure material 27.2 contained in inner bladder 28.2 can form a relatively soft, flexible and resilient material when cured. As shown, shin guard 20.3 can be formed by three layers of film 26 which are affixed together using radio frequency welding, or alternately, can be formed in two separate bladder portions. When shin guard 20.3 consists of a single integral unit, it can be advantageous that the light cure material 27.1 used in outer bladder 28.1 not cure prior to the cure of the light cure material 27.2 used in inner bladder 28.2, and/or the light cure material 27.1 should be substantially transparent or otherwise permit adequate light energy to reach light cure material 27.2 in order to cause it to cure. When shin guard 20.3 is formed in two separate bladder portions, the inner bladder 28.2 can be donned by a wearer and cured, then the outer bladder 28.1 be donned and secured in functional relation thereto and cured. The two separate bladder portions can be affixed to one another with the used of a self-adhesive material, light cure adhesive material, snap, friction fit, VELCRO® hook and pile, or other conventional mechanical means, and the like.

FIG. 5 is a cross-sectional view of a shin guard 20.4 including an inner bladder 28.2 containing a void 50 that is filled with a gas 51. Other articles of protective equipment such as guards, pads, and helmets can include a bladder 28 containing a light cure material 27 and a gas 51, or a mixture of gases such as air. A captive gas 51 or a mixture of gases

can be pressurized above or at atmospheric pressure. As shown, outer bladder 28.1 and inner bladder 28.2 are configured in an overlapping relationship. Light cure material 27.1 contained in bladder 28.1 can form a relatively rigid material when cured. Filler materials such as woven or non-woven textiles made of glass, aramide, or carbon fiber can also be included within bladder 28.1. Shin guard 20.4 can be formed by three layers of film 26 which are affixed together using radio frequency welding, or alternately, a shin guard can be formed in two separate bladder portions.

Gas filled bladders taught by Marion F. Rudy and licensed to Nike, Inc. include U.S. Pat. Nos. 5,543,194, 5,083,361, 5,042,176, 4,936,029, 4,906,502, 4,340,626, 4,287,250, 4,271,606, 4,219,945, and 4,183,156, all of these patents being hereby incorporated by reference herein. Other patents relating to thermoplastic film for use in fluid filled bladders and/or the structure of fluid filled bladders which are believed to be assigned or licensed to Nike, Inc. include U.S. Pat. Nos. 5,406,719, 5,592,706, 5,626,657, 5,755,001, 5,802,739, 5,832,630, 5,979,078, 5,993,585, 6,013,340, 6,020,055, 6,082,025, 6,119,371, 6,127,026, 6,258,421, 6,321,465 B1, WO 01/170060 A2, WO 01/170061 A2, WO 01/170062 A2, WO 01/170063 A2, WO 01/170064 A2, and WO 01/78539 A2, all of these patents being hereby incorporated by reference herein. A Gas filled bladder for making a shock absorbing cushion is taught in U.S. Pat. No. 6,161,240 granted to Ing-Jing Huang, this patent being hereby incorporated by reference herein. Gas filled bladders or other cushioning mediums granted to Martyn Shorten and/or Joseph Skaja include U.S. Pat. Nos. 5,572,804, 5,976,451, 6,029,962, and 6,098,313, all of these patents being hereby incorporated by reference herein. Gas filled bladders or pads taught by Byron Donzis include U.S. Pat. Nos. 5,235,715, 4,874,640, 4,513,449, 4,486,901, 4,453,271, 4,441,211, 4,370,754, and 4,217,705, all of these patents being hereby incorporated by reference herein. Teachings related to athletic equipment by J. C. Wingo include U.S. Pat. Nos. 5,036,761, 5,035,009, 5,029,341, 4,985,931, 4,926,503, and 4,872,216, all of these patents being hereby incorporated by reference herein.

FIG. 6 is a front perspective view of a shin guard 20.5 including two bladders 28.1, and 28.2, configured in a side-by-side relationship, and containing light cure materials having different physical and mechanical properties. Light cure material 27.1 contained in bladder 28.1 can form a relatively rigid material, and light cure material 27.2 contained in bladder 28.2 can form a relatively soft, flexible and resilient material when cured. The shin guard 20.5 can be characterized by alternating areas of relative rigidity and flexibility, thus permitting the shin guard 20.5 to easily conform to the anatomy of a wearer, and to accommodate the flexion of lower leg muscles associated with movement.

In addition, a shin guard can be combined with a knee guard and then be formed as an integral unit. A flexible light cure material can be used in the area between the shin guard and knee guard so as to permit flexion. Nevertheless, the knee and shin can be substantially protected by rigid material. Accordingly, it can be readily understood that the present invention can be used to make articulating body armor, and like guards, and pads. An example of a combination batter's shin and ankle guard is taught in U.S. Pat. No. 5,742,938 assigned to Rawlings, Inc., hereby incorporated by reference herein.

FIG. 7 is a side cross-sectional view of a shin guard 20.6 having a bladder 28 including a light cure material 27. The bladder 28 consists of a relatively thin and substantially transparent film 26 that is affixed to a different material, such

as a textile material **41**, or as shown, a foam material **38**. The foam material **38** can consist of an open or closed cell foam, but a closed cell foam is generally advantageous for use when the foam material will also serve as a portion of the wall of a bladder **28**. The preferred foam material **38** can be made of polyurethane, ethylene vinyl acetate, or a natural or synthetic foam rubber material. The bladder **28** can be affixed to the foam material **38** by sewing, adhesive means, or by radio frequency, microwave, ultrasound, or heat and pressure welding, or other conventional means. A foam material **38** can be made in a complex and generally anatomically conforming shape, including, but not limited to the method taught in U.S. Pat. No. 5,118,722 assigned to Illbruck GmbH, hereby incorporated by reference herein.

FIG. **8** is a transverse cross-sectional view of a shin guard **20.7** including a bladder **28** containing light cure material **27** and a foam material **38**. The foam material **38** is preferably made of a substantially closed cell or microcellular foam material. The foam material **38** can be characterized by various contours and features such as peaks **39** and valleys **40**, thus the relative proportion of foam material **38** and light cure material **27** can be engineered to vary in any given portion of the shin guard **20.7**, as desired. The resulting shin guard **20.7** will then be heterogeneous, that is, be characterized by different physical and mechanical properties in different select locations, as desired. The foam material **38** can be affixed to the outer side of the film **26** used on the inner layer **30** of the bladder **28** by adhesive means, or by radio frequency, microwave, ultrasound, or heat and pressure welding, or other conventional means. As shown, the film **26** forming the both the inner layer **30** of the bladder **28** and the outer layer **29** of the bladder **28** can be affixed at mating edges by welds **101**.

FIG. **9** is a transverse cross-sectional view of a shin guard **20.8** including light cure material **27** within a bladder **28** that is made of a substantially transparent material affixed to a relatively non-transparent material. The non-transparent material can be made of a substantially closed cell or microcellular foam material **38**, a natural or synthetic fiber material, a textile material **41**, a thermoplastic material, a thermoset material, or a natural or synthetic rubber, and the like. The relatively non-transparent material, e.g., a foam material **38**, can be characterized by various contours and features such as peaks **39** and valleys **40**, thus the proportion of foam material **38** and light cure material **27** can be engineered to vary in any given portion of the shin guard **20.8**, as desired. The resulting shin guard **20.8** will then be heterogeneous, that is, characterized by different physical and mechanical properties in different select locations, as desired. The substantially transparent film **26** can be affixed to the outer side of the foam material **28** by adhesive means, or alternately by radio frequency, microwave, ultrasound, or heat and pressure welding, and the like. As shown, the film **26** forming the both the inner layer **30** of the bladder **28** and the outer layer **29** of the bladder **28** can be affixed at mating edges by welds **101**.

FIG. **10** is a perspective view of a sock having a pocket therein, hereinafter referred to as a pocket sock **42** made of textile material **41** with parts broken away, including means for securing a shin guard **20.1** in functional relation thereto. The pocket sock **42** can include an inside layer **43** and an outside layer **44** and have an access point **45** to a sleeve or pocket **46** in which the shin guard **20.1** can be positioned. The inside layer **43** and outside layer **44** of the pocket sock **42** can be affixed together by conventional means at an inferior portion near the malleoli **24**, or alternately, near the superior portion of the pocket sock **42**. In the first case, the

outside layer **44** can be rolled down in order to secure the shin guard **20.1** in place, and in the second case, the outside layer **44** can be rolled up in order to accomplish the same. Alternately, the inside layer **43** and outside layer **44** of the pocket sock **42** can consist of a single component which forms two or more layers by simply folding and doubling the pocket sock **42** over upon itself. The shin guard **20.1** can be positioned and held in place in relation to the pocket sock **42** with the use of friction fit, snaps, straps, VELCRO® hook and pile, zipper, self-adhesive, adhesive, or other conventional means.

When it is desired to form a new shin guard **20.1** in conformance with a wearer's anatomy, the shin guard **20.1** including light-cure material **27** can be removed from a container in which it is stored and shipped that does not permit the passage of substantial ultraviolet or visible light therethrough, and then placed in position on the wearer's lower leg **22** with or without the presence of pocket sock **42**. Exposure of the shin guard **20.1** to sunlight or a suitable man-made light source can cause the shin guard **20.1** to cure in less than 5 minutes. Depending upon the configuration of the shin guard **20.1**, it can sometimes be advantageous for the wearer to engage in movement while the light cure material **27** is being caused to cure in order to better accommodate the flexion of the wearer's muscles. When the shin guard **20.1** has been positioned in functional relationship to a pocket sock **42**, and the like, the outside layer **44** of the pocket sock **42** can be rolled up or down, the light cure material **27** be caused to cure, and then the outside layer **44** of the pocket sock **42** can simply be rolled back up or down and into place. Essentially, all that a consumer or wearer has to do is to put the shin guard **20.1** on and go out and play. The technology associated with the creation of a customized shin guard having a permanent memory capability thus largely takes care of itself. The process is quick, clean, easy, effective, and inexpensive.

FIG. **11** is a front or anterior view of a football player wearing a helmet **70**, a uniform **102** with parts broken away, and a plurality of guards or pads. Shown are shin guard **20**, knee pad **48**, thigh pad **86**, hip pad **87**, rib pad **88**, shoulder pad **89**, elbow pad **54**, glove **90**, forearm pad **53**, biceps pad **91**, neck pad **92**, helmet **70**, and chin strap **47**. All of the aforementioned guards, pads, and other articles of apparel and protective equipment can be made to include a light cure material for effecting a custom fit.

FIG. **12** is a perspective view of a chin-strap **47** including light cure material **27**. Examples of chin guards and straps that are known in the art include U.S. Pat. Nos. 5,794,274, and 4,646,368 assigned to Riddell, Inc. As shown, the chin strap **47** can include a flexible bladder **28** including light cure material **27**, and the outer layer **29** of the bladder **28** can include a substantially transparent material. Alternately, the chin strap **47** can include a textile material which is impregnated with a light cure material. Accordingly, when it is desired to form a chin strap **47** in conformance with a wearer's anatomy, the chin strap **47** including light cure material **27** can be removed from a container in which it is stored and shipped that does not permit the passage of substantial ultraviolet or visible light therethrough, and the wearer can simply attach and use the chin strap **47**. In the presence of sunlight or ambient light conditions the light cure material **27** can be caused to cure and capture the anatomical features of the wearer. It can be advantageous that the inner layer **30** of the bladder of chin strap **47** be made of a stretchable and elastic or otherwise flexible material capable of elongation and distention so as to accommodate the anatomical features of the wearer.



FIG. 13 is a perspective view of a preferred knee pad 48 including a bladder 28 containing a light cure material 27. The material used as the inner layer 30 of the bladder 28 of knee pad 48 can include peaks 39 and valleys 40 which can be substantially encapsulated by the light cure material 27. The inner layer 30 of the knee pad 48 can be made of a foam material 38. The preferred foam material 38 is made of a substantially closed cell or microcellular foam. The foam material 38 can be characterized by various contours and features such as peaks 39 and valleys 40, thus the proportion of foam material 38 and light cure material 27 can be engineered to vary in any given portion of the knee pad 48. The resulting knee pad 48 will then be heterogeneous, that is, characterized by different physical and mechanical properties in different select locations, as desired. Alternately, the inner layer of the knee pad can be made of a natural or synthetic fiber material, a textile material, a thermoplastic material, a thermoset material, a natural or synthetic rubber, and the like. It can be advantageous that the inner layer 30 of the bladder 28 of knee pad 48 be made of a stretchable and elastic material 93 or otherwise flexible material capable of elongation and distention so as to accommodate the anatomical features of the wearer 21. The substantially transparent film 26 can be affixed to the outer side of the foam material 38 or other material used to make the inner layer 30 of the bladder 28 by adhesive means, or alternately by radio frequency, microwave, ultrasound, or heat and pressure welding, and the like.

FIG. 14 is a top plan view of a forearm pad 53 including light cure material 27. Shown on the right side of the forearm pad 53 are openings 49 for permitting heat dissipation and evaporation of sweat. Shown in the middle portion of the forearm pad 53 is a plurality of voids 50 filled with a gas 51 for attenuating force applications. The captive gas can be at atmospheric pressure, or greater than atmospheric pressure. The voids 26 can constitute chambers 100 which are at least initially interconnected by passages 103. The chambers 100 and passages 103 can be formed by radio frequency welding of the film 26 which forms at least the outer layer 29 of the bladder 28. The chambers 100 can be filled with a gas and then isolated by welds 101 made to block passages 103, as desired.

FIG. 15 is a top plan view of an elbow pad 54 including a bladder 28 containing light cure material 27. The material used in the inner layer 30 of elbow pad 54 includes peaks 39 and valleys 40 which permit the light cure material 27 to substantially encapsulate the inner layer 30 of the elbow pad 54. The inner layer 30 of the elbow pad 54 can be made of a foam material 38. The foam material 38 is preferably a substantially closed cell or microcellular foam. The foam material 38 can be characterized by various contours and features such as peaks 39 and valleys 40, thus the proportion of foam material 38 and light cure material 27 can be engineered to vary in any given portion of the elbow pad 54. The resulting elbow pad 54 can then be heterogeneous, that is, characterized by different physical and mechanical properties in different select locations, as desired. Alternately, or in addition to inclusion of a foam material 38, the inner layer 30 of the elbow pad 54 can be made of a natural or synthetic fiber material, a textile material, a thermoplastic material, a thermoset material, a natural or synthetic rubber, and the like. It can be advantageous that the inner layer 30 of the elbow pad 54 be made of a stretchable and elastic 93 or otherwise flexible material capable of elongation and distention so as to accommodate the anatomical features of the wearer. The substantially transparent film 26 can be affixed in function relation to the outer side of the foam material 38

or other material used to make the inner layer 30 of the bladder 28 by adhesive means, or alternately by radio frequency, microwave, ultrasound, or heat and pressure welding, and the like.

FIGS. 16.1 and 16.2 are perspective views showing the bones of the skull 56 of a newborn in FIG. 16.1 and a mature adult in FIG. 16.2. Shown are the skull 56, occipital bone 57, parietal bone 58, temporal bone 59, sphenoid bone 60, frontal bone 61, anterior fontanelle 62, posterior fontanelle 63, sagittal suture 96, coronal suture 64, lambdoid suture 65, squamous suture 66, sphenoidal fontanelle 67 and mastoid fontanelle 68. By adulthood, the various fontanelles of the skull are normally transformed into bone and disappear, and the sutures of the skull will close.

However, some individuals consider that the sphenoid and temporal bones can be capable of limited articulation even in an adult. In fact, it is believed that this portion of the skull 56 pulses several times per minute in connection with the circulation of cerebral-spinal fluid in the brain and spine, and serves to drive the large reservoirs of cerebral-spinal fluid that are contained within the brain cavity. Immobilization of these bones of the skull can then lead to headaches and mental disturbance, such as a diminished ability to concentrate. The tendency of individuals to rub their temples in order to relieve a headache is then an appropriate therapy, as prolonged muscle tension can have the effect of immobilizing or hindering normal articulation. In the field of physical therapy, treatment based upon this phenomenon is known as craniosacral therapy. It can therefore be readily understood that a helmet which places significant pressure on the areas of the temporal or sphenoid bones, or about the base of the skull proximate the first vertebra can prove dysfunctional for use by a wearer.

Helmets known in the football prior art include U.S. Pat. Nos. 5,263,203, 5,175,889, 5,035,009, 4,831,668, 4,287,613, 3,866,243, assigned to Riddell, Inc. An adjustable baseball batter's helmet is taught in U.S. Pat. No. 5,575,017 assigned to Rawlings, Inc. An adjustable hockey helmet is taught in U.S. Des. 378,624 assigned to Canstar Sports Inc. Bicycle helmets made by Specialized Bicycle Components, Inc., PDH Corporation, Bell Sports, Inc., and Giro Sport Design, Inc., include U.S. Pat. Nos. 5,794,272, 5,381,560, 5,659,900, 5,481,762, 4,993,082, and 4,903,350. All of the U.S. patents cited in this paragraph are hereby incorporated by reference herein.

FIG. 17 is a perspective view of helmet liner 69 including a bladder 28 containing light cure material 27 positioned upon a wearer's head 71. The material used in that portion of the helmet liner 69 positioned against the head 71 can be substantially encapsulated by the light cure material 27. The material used proximate the head 71 can be a foam material 38. The foam material 38 is preferably a substantially closed cell or microcellular foam. The foam material 38 can be characterized by various contours and features such as peaks 39 and valleys 40, thus the proportion of foam material 38 and light cure material 27 can be engineered to vary in any given portion of the helmet liner 69. The resulting helmet liner 69 can then be heterogeneous, that is, characterized by different physical and mechanical properties in different select locations, as desired. Alternately, or in addition, the inner layer 30 of the helmet liner 69 can be made of a natural or synthetic fiber material, a textile material, a thermoplastic material, a thermoset material, a natural or synthetic rubber, and the like. It can be advantageous that the inner layer 30 of the helmet liner 69 be made of a stretchable and elastic 93 or otherwise flexible material capable of elongation and distention so as to accommodate the anatomical features of

the wearer. The substantially transparent film 26 can be affixed to the foam material 38 or other material used to make the inner layer 30 of the bladder 28 by adhesive means, or alternately by radio frequency, microwave, ultrasound, or heat and pressure welding, and the like.

It can be advantageous that the helmet liner 69 be made having several different bladders 28, or several different chambers 100 which generally imitate the position of the major bones of the skull 56, that is, two opposing temporal and sphenoidal bladders 72 protecting the sides of the head proximate the temple and ear, an occipital bladder 73 protecting the back of the head 71, a parietal bladder 74 protecting the top of the head 71, and a frontal bladder 75 protecting the front of the head 71. Alternately, the parietal bladder 74 and frontal bladder 75 can be made in two generally opposing bladders or chambers 100 each protecting their respective medial or lateral aspect of the head 71. Many other configurations for a helmet liner 69 can be used. When the helmet liner 69 extends near or below the position of the ear, it can sometimes be advantageous that an aperture or opening 49 be provided so that the wearer's 21 hearing will not be significantly impaired. The aforementioned configuration of the helmet liner 69 facilitates conformance to the unique anatomical features of a wearer's head 71, due to the fact that the junction points between the respective bladders 28 or chambers 100 are located proximate the various sutures of the skull 56, and these areas of the helmet liner 69 are characterized by relatively thin cross-sections and resulting flexibility.

The wearer 21 can remove the helmet liner 69 including light cure material 27 from the container or package in which it is stored and shipped that does not permit the passage of substantial ultraviolet and visible light there-through. When the various bladder 28 or chambers 100 are affixed in functional relation to a stretchable and elastic material 93, such as a closed cell foam material, or a stretchable and elastic textile material 41 which is used at least at the junction points between respective bladders 28 or chambers 100, the wearer 21 can simply don the helmet liner 69 and it will be caused to conform to their particular anatomical conformance, that is, the size and shape of their head 71. In the presence of sunlight or a suitable man-made light source, the light cure material 27 contained within helmet liner 69 can be caused to cure, thereby retaining a custom fit and permanent memory. As shown in FIG. 21, a helmet 70.4 or helmet liner 69 can include retaining means such as a chin strap 47. Further, in some applications, it can be readily understood that the so-called helmet liner 69 shown in FIG. 17 can also constitute a suitable helmet 70.1 for use by a wearer 21. For this reason, drawing FIG. 17 has been identified as both a helmet liner 69, and a helmet 70.1.

FIG. 18 is a bottom perspective view of a helmet liner 69 secured in function relation to a relatively rigid outer shell 97 of a helmet 70.2. Shown are two opposing temporal and sphenoidal bladders 72 for protecting the sides of the head proximate the temple and ear, an occipital bladder 73 for protecting the back of the head, a parietal bladder 74 for protecting the top of the head 71, and a frontal bladder 75 for protecting the front of the head 71. Alternately, the parietal bladder 74 and frontal bladder 75 can both be made in two generally opposing bladders 28 or chambers 100 each protecting their respective medial or lateral aspect of the head 71. The aforementioned configuration of the helmet liner 69 facilitates conformance to the unique anatomical features of a wearer's head 71, due to the fact that the junction points between the respective bladders 28 or chambers 100 are located proximate the various sutures of the skull 56, and

these areas of the helmet liner 69 are characterized by relatively thin cross-sections and resulting flexibility. The helmet liner 69 can include a single bladder 28 having a plurality of chambers 100, a plurality of bladders 28, or a plurality of bladders 28 which include a plurality of chambers 100. When the helmet liner 69 extends near or below the position of the ear, it can sometimes be advantageous that an aperture or opening 49 be provided so that the wearer's 21 hearing will not be significantly impaired. The helmet liner 69 can be secured to the helmet 70.2 by snaps 77, VELCRO® hook and pile 78, adhesive, self-adhesive 79, straps, and other conventional means, whether in partial or complete combination.

FIG. 19 is a side perspective view of a helmet 70.2. Helmet 70.2 can be substantially made of a single material, or a plurality of materials. The outer shell 97 of helmet 70.2 can be made of a metal such as aluminum, steel, or titanium, a carbon fiber or glass composite material, a thermoplastic material such as polycarbonate or nylon, or a foam material such as a rigid foam. Various laminate helmet constructions are taught in U.S. Pat. No. 5,190,802, this patent hereby being incorporated by reference herein, and also the prior art patents recited therein. Alternately, the outer shell 97 of a helmet 70.2 can be made of a light cure material 27.

Alternately, as shown in FIG. 20, a helmet 70.3 can be made of a plurality of segments 80 having light cure material 27 positioned therebetween. Further, the outer surface 108 of the outer shell 97 of a helmet 70.3 for use in soccer can include a tactified outer surface 106, a textured outer surface 107, and an outer surface 108 including raised grip elements 105, whether in partial or complete combination, for facilitating and possibly enhancing a wearer's ability to play a soccer ball when heading the ball, as desired. The outer shell 97 of the helmet 70.3 can include an elastomeric coating, such as polyurethane, and/or a thermoset or thermoplastic material such as natural or synthetic rubber. Suitable hybrid thermoplastic and rubber combinations can be used, including dynamically vulcanized alloys which can be injection molded such as those produced by Advanced Elastomer Systems, 338 Main Street, Akron, Ohio 44311, e.g., SANTOPRENE®, VYRAM®, GEOLAST®, and TREF-SIN®. SANTOPRENE® is known to consist of a combination of butyl rubber and ethylene-propylene. Some of the elastomeric thermoplastic materials made by Advanced Elastomer Systems, such as SANTOPRENE®, can be bonded to relatively rigid thermoplastic materials, such as nylon, for making the outer shell 97 of a helmet 70.3. Another suitable material for use in making the outer shell 97 of a helmet 70.3 is polycarbonate. Soccer balls having advantageous geometry and tactified surfaces are taught in U.S. Pat. Nos. 5,040,795, and 5,181,717, assigned to Adidas, International. Soccer shoes having a textured and tactified outer surface including raised grip elements are taught in U.S. Pat. No. 5,437,112, granted to Craig Johnson, a technology which is licensed and commercialized by Adidas, International under the PREDATOR® tradename. It can be readily understood that any or all of the alternate embodiments of a helmet taught herein can include a tactified outer surface, textured outer surface, or an outer surface including raised grip elements 105, in partial or complete combination. Moreover, regardless of whether a helmet be customized with the use of light cure material as recited herein, it can be readily understood that it can possibly be advantageous to use of helmet including a tactified outer surface, textured outer surface, or an outer surface including raised grip elements 105, in partial or complete combination.

Alternately, as shown in FIG. 21, a helmet 70.4 can be made of a plurality of segments 80 which are substantially

encapsulated by light cure material **27**. Further, it can be readily understood that a helmet liner can be formed integrally with the outer shell of a helmet. A wearer **21** can remove the helmet including light cure material from a container or package in which it is stored and shipped that does not permit the passage of substantial ultraviolet and visible light therethrough, and the wearer can simply attach the helmet in the presence of sunlight or a suitable man-made light source, and the light cure material can be caused to cure while conforming to the anatomical features of the wearer, thereby retaining a custom fit and permanent memory.

FIG. **22** is a perspective view of a back support **81** for supporting the lower back **94** of a wearer **21**. A physical therapist can remove the back support **81** including light cure material **27** from a container or package in which it is stored and shipped that does not permit the passage of substantial light energy therethrough, and can place the patient's back and hips in a neutral or other desired position, then position the back support **81** in functional relation to the patient. In the presence of sunlight or a suitable man-made light source the light cure material **27** can be caused to cure while conforming to the anatomical features of the wearer **21**, thereby retaining a custom permanent memory.

FIG. **23** is a perspective view of a hand **84** and wrist **76** having a wrist guard **82**, such as a brace, splint, or support affixed in position upon a wearer **21**. The wrist support **82** can include a light cure material **27** contained in at least one bladder **28**. The wrist support **82** can include a foam material **38**, or other material. The foam material **38** is preferably a substantially closed cell or microcellular foam. The foam material **38** can be characterized by various contours and features such as peaks **39** and valleys **40**, thus the proportion of foam material **38** and light cure material **27** can be engineered to vary in any given portion of the wrist support **82**. The resulting wrist guard **82** can then be heterogeneous, that is, characterized by different physical and mechanical properties in different select locations, as desired. Alternately, the inner layer **30** of the hand and wrist support **82** can be made of a natural or synthetic fiber material, a textile material, a thermoplastic material a thermoset material, a natural or synthetic rubber, and the like. It can be advantageous that the inner layer **30** of the wrist guard **82** be made of a stretchable and elastic or otherwise flexible material capable of elongation and distention so as to accommodate the anatomical features of the wearer. The substantially transparent film **26** can be affixed to the outside of the foam material **38** or other material used to make the inner layer **30** of the bladder **28** by adhesive means, self-adhesive, or alternately, by radio frequency, microwave, ultrasound, or heat and pressure welding, and the like.

The wrist support **82** can also include a rigid member **83** for substantially preventing flexion of the hand **84** relative to the forearm **85** in one or more directions. This can be advantageous for use with individuals suffering from carpal tunnel syndrome, and can also be used to create a hand and wrist guard **82** suitable for use by in-line skaters. Wrist guards suitable for the treatment of carpal tunnel syndrome include U.S. Pat. Nos. 5,769,804, 5,766,141, and 5,014,689, all of these patents hereby being incorporated by reference herein. Wrist guards suitable for in-line skaters include U.S. Pat. Nos. 5,813,050, 5,778,449, and 5,435,007 assigned to Rollerblade, Inc., all of these patents hereby being incorporated by reference herein.

An alternate embodiment and method of making any or all of the various preferred and alternate embodiments of an article of apparel, guard, pad, brace, or helmet recited herein

can include the use of an impregnated textile material **55**, that is, a textile material **41** which is coated or saturated with a light cure material **27**. Impregnated textile materials **55** which can be cured using sunlight or a suitable man-made light source to make casts are known in the prior art, e.g., U.S. Pat. No. 4,512,340 granted to Carl Buck. The preferred impregnated textile material **55** can be made of a woven or non-woven material, a natural or synthetic material, glass, rayon, aramide KEVLAR®, or carbon fiber, and the like. A fiberglass material is generally preferred due to considerations of weight, cost, and also the ability to use radio frequency welding techniques in order to seal polyurethane film materials to form a bladder in close proximity with fiberglass materials, something which is not advisable to attempt with carbon fiber materials due to their electrical conductivity. The preferred fiberglass materials for use are VX **171**, VX **180**, and VX **191** made by V2 Superior Composite Reinforcement Fabrics of 770 Lee Road 191, Auburn, Ala. These fiberglass materials have a biax 45 degree weave and are reinforced with rows of continuous stitching having a separation of less than 1/8ths of one inch, and also have a weight between 17–20 ounces per square yard. VX **191** and VX **171** are generally preferred as the woven fibers included therein measure less than or equal to 1/8th in width. As a result, the individual fibers are less likely to fray and wander when cut, and also the weave of both these materials is relatively tight and cosmetically appealing. It can be advantageous to use a single or double sided adhesive tape applied to the back side of the fiberglass or other textile when cutting the material to made the desired or required pattern, as this can help to maintain the integrity of the material and also prevent cut fiber portions from fraying or wandering. In particular, the wandering of fiber portions can later become a manufacturing problem if and when the textile material is to be inserted into a bladder which is to be sealed using radio frequency welding or other conventional techniques, since the intrusion of fiber portions can sometimes degrade the quality of the resulting weld and fluid integrity of the bladder. Further, the use of a double-sided adhesive tape can be advantageous in properly locating and affixing a textile material in a desired registered position relative to a polyurethane film material which can be used to make a bladder. A preferred double sided adhesive tape for use is RAP Hold 10 made by Richmond Aircraft Products, Inc. of Norwalk, Calif.

However, as shown in FIG. **24**, a perspective view of a shin guard **20.9**, with parts broken away, it can be advantageous to enclose an impregnated textile **55** within a bladder **28**, as this can both reduce oxygen inhibition with respect to the cure of some light cure materials **27**, and prevent a user or wearer **21** from coming into direct physical contact with uncured light cure material **27**. The impregnated textile material **55** can be made of a woven or non-woven material, a natural or synthetic material, glass, rayon, aramide KEVLAR®, or carbon fiber, and the like. The light cure material **27** used to impregnate the textile material can form a rigid, or alternately, a non-rigid material when cured, as desired. An impregnated textile material **55** can also be used with other cushioning materials such as padding, foam material, or a fluid filled bladder including a gas. In some cases, shin guard **20.9** can possibly be removed from the bladder **28** after being cured by a suitable light source, and then be used by a wearer **20**, as desired.

FIG. **25**, is a perspective view of a shin guard **20.10** substantially consisting of an impregnated textile material **55** which forms the exterior portion. An impregnated textile material **55** can be used to make a shin guard, pad, helmet

or other article of apparel. The impregnated textile material **55** can be made of a woven or non-woven material, a natural or synthetic material, glass, rayon, aramide KEVLAR®, or carbon fiber, and the like. Impregnated textile materials **55** are sometimes identified as “prepreg” materials. The surface of some uncured “prepreg” materials can be only slightly tacky to the touch, thus “prepreg” materials can be relatively easy to handle and manipulate with rubber gloves. Alternately, a thin layer of substantially transparent protective film **104** such as PVdC, or shrink wrap, can be used to cover the exterior surface of the impregnated textile material **55**. After the article including the impregnated textile material **55** is donned by a wearer, and shaped to fit and cured, the thin layer of protective film **104** can possibly be removed. The light cure material **27** used to impregnate the textile material can form a rigid, or alternately, a non-rigid material when cured, as desired. An impregnated textile material **55** can be used with other cushioning materials such as padding, foam material, or a fluid filled bladder containing a gas.

FIG. **26** is a perspective view of an alternate helmet **70.5**, with parts broken away, including an impregnated textile **55** within a bladder **28**. This configuration can both reduce oxygen inhibition with respect to the cure of some light cure materials **27**, and prevent a user or wearer **21** from coming into direct physical contact with uncured light cure material **27**. The impregnated textile material **55** can be made of a woven or non-woven material, a natural or synthetic material, glass, rayon, aramide KEVLAR®, or carbon fiber, and the like. The light cure material **27** used to impregnate the textile material can form a rigid, or alternately, a non-rigid material when cured, as desired. An impregnated textile material **55** can be used with other cushioning materials such as padding, foam material, or a fluid filled bladder including a gas. In some cases, the helmet **70.5** can be possibly removed from the bladder **28** after being cured by a suitable light source, and then be used by a wearer **20**, as desired.

FIG. **27**, is a perspective view of a helmet **70.6** substantially consisting of an impregnated textile material **55** which forms the exterior portion. Again, an impregnated textile material **55** can be used to make a shin guard, pad, helmet or other article of apparel. The impregnated textile material **55** can be made of a woven or non-woven material, a natural or synthetic material, glass, rayon, aramide KEVLAR®, or carbon fiber, and the like. Impregnated textile materials **55** are sometimes identified as “prepreg” materials. The surface of some uncured “prepreg” materials can be only slightly tacky to the touch, thus “prepreg” materials can be relatively easy to handle and manipulate with rubber gloves. Alternately, a thin layer of substantially transparent protective film **104** such as PVdC, or shrink wrap, can be used to cover the exterior surface of the impregnated textile material **55**. After the article including the impregnated textile material **55** is donned by a wearer, and shaped to fit and cured, the thin layer of protective film **104** can possibly be removed. The light cure material **27** used to impregnate the textile material can form a rigid, or alternately, a non-rigid material when cured, as desired. An impregnated textile material **55** can also be used in conjunction with other materials such as padding, foam material, or a fluid filled bladder including a gas.

FIG. **28** is an anterior plan view of a shin guard **20.11** having a symmetrical shape near the area corresponding to a wearer’s medial malleolus **33.1** and lateral malleolus **33.2**. The plantar strap **117** for passing under a wearer’s foot, and also the stretchable inferior guard **128** for encompassing a

wearer’s lower leg and ankles have been cut so that the shin guard **20.11** can be flattened out and shown with greater accuracy. The plantar strap **117** measures approximately four inches in length, and one half inch at both ends of the strap **117** overlap a portion of the inferior guard **128** of the shin guard **20.11** and are affixed by stitches **119** near the inferior edge **110**. As shown in FIG. **28**, a strip of female VELCRO® **78.2** or pile which can measure one inch in width and seven and one half inches in length is affixed by stitches **119** can extend substantially across the shin guard **20.11** near the superior side **109**, and a strap **118** having a length of approximately ten inches including a two inch portion of male VELCRO® **78.1** or hook at the distal end can extend from the medial side **112** of the shin guard **20.11**. The strap **116** can extend about a wearer’s lower leg and the male VELCRO® **78.1** can then be affixed to the female VELCRO® **78.2**. The shin guard **20.11** also includes a portion of edge trim **118** that can be affixed by stitches **119** about a plurality of edges for providing cushioning and enhancing comfort. The shin guard **20.11** has an access point **45** to a pocket **46** near the superior edge **109** which extends substantially between the medial side **122** and lateral side **113** and generally parallel to the transverse axis **115**. The pocket **46** can possibly measure slightly less than eight inches in width as measured along the transverse axis **115** and less than twelve inches in height as measured along the longitudinal axis **114**. A layer of relatively thin plastic film **26** measuring between 10–50 mils in thickness such as a substantially transparent polyurethane film made by Deerfield Urethane, Inc. of Deerfield, Mass. can be used to make the anterior side **120** of the pocket **46**, whereas the posterior side **121** of the pocket **46** can be made of a fabric or textile material including one or more layers which can include a foam material and also a plurality of openings **49** there-through for enhancing ventilation. As shown in FIG. **28**, the shin guard **20.11** includes a superior guard **127** portion for protecting the wearer’s lower leg, and an inferior guard **128** portion for protecting the wearer’s ankles or medial and lateral malleoli. The inferior guard **128** can be made of a stretchable woven or knit fabric such as one made of a blend of 30 percent natural cotton fiber with 60 percent polyester fiber and 10 percent elastic material such as SPANDEX®, or LYCRA®, and the like, made by the DuPont de Nemours company of Wilmington, Del., or alternately, an elastomeric material such as a foamed neoprene rubber including a stretchable textile laminate. As shown in FIG. **28**, the inferior guard **128** measures approximately four inches in height along the area which has been severed, that is, as measured along the longitudinal axis **114**, and approximately eight inches in width between the medial side **112** and the lateral side **113**. The inferior guard **128** can also include a medial malleolus pad or guard **33.1** and a lateral malleolus pad or guard **33.2** which can be made of a plastic, rubber, or foam material. The approximate position of the most prominent portion of the medial malleolus is indicated by an X and numeral **123**, whereas the approximate position of the most prominent portion of the lateral malleolus is indicated by an X and numeral **124**.

FIG. **29** is an anterior plan view of a shin guard **20.12** having an asymmetrical shape near the area corresponding to a wearer’s medial malleolus and lateral malleolus in which both the plantar strap **117** for passing under a wearer’s foot, and also the stretchable inferior guard **128** for encompassing a wearer’s lower leg and ankles have been cut so that the shin guard **20.12** can be flattened out and shown with greater accuracy. The asymmetrical shape better accommodates for the normal asymmetry that exists between the

relative height of the most prominent portion of a wearer's medial malleolus 123 which is commonly at least approximately 10 mm or one half inch more superior and also more anterior relative to the normal position of the most prominent portion of a wearer's lateral malleolus 124.

FIG. 30 is an anterior plan view of a shin guard 20.13 similar to that shown in FIG. 29 having an asymmetrical shape in which both the plantar strap 117 for passing under a wearer's foot, and also the stretchable inferior guard 128 for encompassing a wearer's lower leg and ankles have been cut so that the shin guard 20.13 can be flattened out and shown with greater accuracy. The shin guard 20.13 also includes openings 49 through the film 26 forming the anterior side 120 of the pocket and openings 49 through the material forming the posterior side 121 of the pocket for enhancing ventilation.

FIG. 31 is an anterior plan view of a shin guard 20.14 including a superior guard 127 generally similar to that shown in FIG. 30 having an asymmetrical shape and including openings 49 for ventilation, but excluding the stretchable inferior guard 128 portion for encompassing a wearer's malleoli. The shin guard 20.14 includes an additional strap 116 that can be affixed by stitches 119 near the inferior side 110.

FIG. 32 is an anterior plan view of a shin guard 20.15 generally similar to that shown in FIG. 30 having an asymmetrical shape and including openings 49 for ventilation in which both the plantar strap 117 for passing under a wearer's foot, and also the stretchable inferior guard 128 for encompassing a wearer's lower leg and ankles have been cut so that the shin guard 20.15 can be flattened out and shown with greater accuracy, but also including a flex notch 122 on the medial side 112. The flex notch 122 can be bridged by a stretchable elastic material 93 which can be affixed by stitches 119, and can possibly enhance accommodation of a wearer's calf muscles on the medial side 112.

FIG. 33 is an anterior plan view of a shin guard 20.16 generally similar to that shown in FIG. 30 having an asymmetrical shape and including openings 49 for ventilation in which both the plantar strap 117 for passing under a wearer's foot, and also the stretchable inferior guard 128 for encompassing a wearer's lower leg and ankles have been cut so that the shin guard 20.16 can be flattened out and shown with greater accuracy, but the pocket 46 extends more inferiorly about the areas corresponding to the medial malleolus 123 and lateral malleolus 124 of a wearer.

FIG. 34 is an anterior plan view of a shin guard 20.17 generally similar to that shown in FIG. 30 having an asymmetrical shape and including openings 49 for ventilation in which both plantar strap 117 for passing under a wearer's foot, and also the stretchable inferior guard 128 for encompassing a wearer's lower leg and ankles have been cut so that the shin guard 20.17 can be flattened out and shown with greater accuracy, but the stretchable inferior guard 128 portion extends approximately three more inches upwards as measured along the longitudinal axis 114.

FIG. 35 is a posterior three dimensional perspective view of a shin guard 20.18 generally similar to that shown in FIG. 34 showing a stretchable inferior guard 128 portion, but also a posterior guard 31. The posterior guard 31 can be made of a foam material and can provide protection for the wearer's Achilles tendon. The plantar strap 117 and stretchable inferior guard 128 are shown in their intact state in FIG. 35, as opposed to their severed representation in FIG. 34. Openings 49 in the material forming the posterior side 121 of the pocket 46 for enhancing ventilation can also be seen in FIG. 35.

FIG. 36 is a posterior three dimensional perspective view of a shin guard 20.19 generally similar to that shown in FIG. 35 showing a stretchable inferior guard 128 portion, but also a posterior guard 31 having a pocket 46 for receiving a bladder 28.3 including light cure material 27, or alternately, a textile material 41 impregnated with a light cure material 27 forming an impregnated textile material 55. The posterior guard 31 can then provide a permanent custom fit for a individual wearer.

FIG. 37 is an anterior plan view of a bladder 28.4 for containing light cure material 27 for use with a shin guard 20.13 having an asymmetrical shape generally similar to that shown in FIG. 30. A bladder 28 can be formed by radio frequency welding together two relatively thin layers of film 26 having a thickness approximately between 5–20 mils. Shown are weld 101 areas including a sealing weld 125, and also a plurality of openings 49 for enhancing ventilation. The anterior side 120 of the bladder 28.4 is made of a substantially transparent film material for transmitting light therethrough. If desired, the posterior side 121 of the bladder 28.4 can include a reflective material 126, and this can serve to reduce the curing time of the light cure material 27.

FIG. 38 is an anterior plan view of a textile material 41 for possible use inside the bladder 28.4 shown in FIG. 37. Again, the textile material can consist of a woven and stitched fiberglass material such as VX 191 made by V2 Superior Composite Reinforcement Fabrics of 770 Lee Road 191, Auburn, Ala.

FIG. 39 is an anterior plan view of a bladder 20.5 generally similar to that shown in FIG. 37 including the textile material 41 shown in FIG. 38 therein, and also including a light cure material 27, thus forming an impregnated textile material 55. Again, a bladder 28 can be formed by radio frequency welding together two relatively thin layers of film 26 having a thickness approximately between 5–20 mils. Shown are weld 101 areas including a sealing weld 125, and also a plurality of openings 49 for enhancing ventilation.

FIG. 40 is an anterior plan view of a foam material 38 including a plurality of openings 49 for possible use within a bladder 28.4 or 28.5 generally similar to those shown in FIG. 37 or FIG. 39. The foam material 38 can be made of polyurethane, ethylene vinyl acetate, natural or synthetic rubber, and the like.

FIG. 41 is an anterior plan view of a foam material 38 including a plurality of openings 49 for possible exterior use in combination with a bladder 28.4 or 28.5 generally similar to those shown in FIG. 37 or FIG. 39. The foam material 38 can be made of polyurethane, ethylene vinyl acetate, natural or synthetic rubber, and the like.

FIG. 42 is an anterior plan view of a reflective material 126 for possible interior or external use in combination with a bladder 28.4 or 28.5 generally similar to those shown in FIG. 37 or FIG. 39. The reflective material 126 can be made of aluminum foil, or alternately and as preferred, a relatively thin plastic film material including leafing grade aluminum particles therein.

FIG. 43 is an anterior plan view of a reflective material 126 generally similar to that shown in FIG. 42 for possible interior or external use in combination with a bladder 28.4 or 28.5 generally similar to those shown in FIG. 37 or FIG. 39, but also having openings 49 for ventilation.

FIG. 44 is an anterior plan view of a shin guard 20.20 with parts broken away to show the use of a foam material 38 posterior of a bladder 28.5. The bladder 28.5 contains light cure material 37 and a textile material 41 impregnated with

light cure material **27** thereby forming an impregnated textile material **55**. The bladder **28.5** is shown located within a pocket **46** of the shin guard **20.20**.

FIG. **45** is an anterior plan view of a shin guard **20.21** with parts broken away to show the use of a foam material **38** inside of a bladder **28.6**. The bladder **28.6** contains light cure material **37** and a textile material **41** impregnated with light cure material **27** thereby forming an impregnated textile material **55**. The bladder **28.6** is shown located within a pocket **46** of the shin guard **20.21**.

FIG. **46** is an anterior plan view of a fluid filled bladder **28.7** for use with a shin guard **20.13** or **20.14** generally similar to those shown in FIG. **30** or FIG. **31**. The fluid filled bladder **28.7** can be filled with ambient air pressurized at atmospheric pressure, or alternately, can be pressurized above atmospheric pressure. Alternately, the fluid filled bladder **28.7** can include a select captive gas such a nitrogen, or a fluid in a liquid or viscous state. Again, gas filled bladders taught by Marion F. Rudy and licensed to Nike, Inc. include U.S. Pat. Nos. 5,543,194, 5,083,361, 5,042,176, 4,936,029, 4,906,502, 4,340,626, 4,287,250, 4,271,606, 4,219,945, and 4,183,156, all of these patents hereby being incorporated by reference herein. Other patents relating to plastic film for use in fluid filled bladders or the structure of fluid filled bladders assigned or licensed to Nike, Inc. include U.S. Pat. Nos. 5,592,706, 5,626,657, 5,755,001, 5,802,739, 5,832,630, 5,979,078, 5,993,585, 6,020,055, 6,082,025, 6,119,371, 6,127,026, 6,258,421, 6,321,465 B1, WO 01/170060 A2, WO 01/170061 A2, WO 01/170062 A2, WO 01/170063 A2, WO 01/170064 A2, and WO 01/78539 A2, all of these patents hereby being incorporated by reference herein. Gas filled bladders or other cushioning mediums granted to Martyn Shorten and/or Joseph Skaja include U.S. Pat. Nos. 5,572,804, 5,976,451, and 6,029,962, all of these patents hereby being incorporated by reference herein. Gas filled bladders or pads taught by Byron Donzis include U.S. Pat. Nos. 5,235,715, 4,874,640, 4,513,449, 4,486,901, 4,453,271, 4,441,211, 4,370,754, and 4,217,705, all of these patents hereby being incorporated by reference herein. Teachings related to athletic equipment by J. C. Wingo include U.S. Pat. Nos. 5,036,761, 5,035,009, 5,029,341, 4,985,931, 4,926,503, and 4,872,216, all of these patents hereby being incorporated by reference herein.

FIG. **47** is an anterior plan view of a shin guard **20.22** with parts broken away to show the use of a fluid filled bladder **28.7** posterior of a bladder **28.5**. The bladder **28.5** contains light cure material **37** and a textile material **41** impregnated with light cure material **27** thereby forming an impregnated textile material **55**. The bladder **28.5** and also bladder **28.7** are shown located within a pocket **46** of the shin guard **20.22**.

FIG. **48** is an anterior plan view of a shin guard **20.23** with parts broken away to show the use of a fluid filled bladder **28.7** inside of a bladder **28.8** containing a light cure material **27** and a textile material **41** impregnated with light cure material **27** thereby forming an impregnated textile material **55**. The bladder **28.8** including bladder **28.7** are shown located within a pocket **46** of the shin guard **20.23**.

FIG. **49** is an anterior plan view of a shin guard **20.24** including a superior guard **127** portion and straps **116**. The shin guard **20.24** has an asymmetrical shape near both the superior side **109** and inferior side **110** as between the medial side **112** and lateral side **113**. The asymmetrical shape shown near the superior side **109** as between the medial side **112** and lateral side **113** can possibly enhance accommodation for a wearer's calf muscles, whereas the asymmetrical shape

shown near the inferior side **110** as between the medial side **112** and lateral side **113** can possibly enhance accommodation for a wearer's malleoli.

FIG. **50** is an anterior plan view of a shin guard **20.25** generally similar to that shown in FIG. **49** having an asymmetrical shape near both the superior side **109** and inferior side **110** as between the medial side **112** and lateral side **113**, but not including straps **116**. Again, the asymmetrical shape shown near the superior side **109** as between the medial side **112** and lateral side **113** can possibly enhance accommodation for a wearer's calf muscles, whereas the asymmetrical shape shown near the inferior side **110** as between the medial side **112** and lateral side **113** can possibly enhance accommodation for a wearer's malleoli.

FIG. **51** is an exploded anterior plan view of a shin guard **20.26** having a superior guard **127** portion generally similar to that shown in FIG. **31** having an asymmetrical shape near the inferior side **110**, and also an inferior guard **128** portion which can be selectively removed and replaced. This can facilitate washing of the inferior guard portion **128** which can include a textile material **41**. This embodiment can also facilitate adjustment of the spacing and relative position between the superior guard **127** portion and inferior guard **128** portion for better accommodating the fit provided to an individual wearer, and also replacement of either portion of the shin guard **20.26**.

FIG. **52** is an anterior plan view of a shin guard **20.27** having an asymmetrical shape near both the superior side **109** and the inferior side **110** as between the medial side **112** and lateral side **113**, and that does not include straps. Again, the asymmetrical shape shown near the superior side **109** as between the medial side **112** and lateral side **113** can possibly enhance accommodation for a wearer's calf muscles, whereas the asymmetrical shape shown near the inferior side **110** as between the medial side **112** and lateral side **113** can possibly enhance accommodation for a wearer's medial malleolus **123** and lateral malleolus **124**.

FIG. **53** is a cross-sectional and exploded view of the shin guard **20.27** shown in FIG. **52**. Shown is an outer layer **29** and an inner layer **30** of a bladder **28** which can be made of thermoplastic film **26** and sealed by radio frequency welding. A textile material **41** such as woven fiberglass having a thin double sided self-adhesive surface **79** such as double sided tape or a double sided foam tape affixed to a portion of its posterior most side **121** can be affixed in registered position upon the inner layer **30** of film **26**, and then the outer layer **29** of film **26** can be placed in registered position and the bladder **28** nearly completely sealed using radio frequency welding. A suitable amount of light cure material **27** sufficient to saturate a textile material **41**, such as a woven or non-woven fiberglass material, can then be inserted into the bladder **28**, thereby creating an impregnated textile material **55**, and the bladder **28** can then be completely sealed. Alternately, an impregnated textile material **55** such as a "prepreg" fiberglass material can simply be sealed within a bladder **28**. Alternately, an impregnated textile material **55** such as a "prepreg" fiberglass material can be covered on at least the anterior side **120** with a thin layer of substantially transparent plastic film material **26**. Also shown in FIG. **53** is a textile material **41** which is affixed in functional relation to a foam material **38**. The foam material **38** can include a self-adhesive surface **79** on its anterior most side for affixing to the posterior most side of the inner layer **30** of the bladder **28**. Also shown on the medial side **112** and lateral side **113** is edge trim **118** which can be affixed by stitches **119**, adhesives, welding, or other conventional means. When stitches **119** are used to affix the edge trim **118**

they are so located as to pass through a portion of the film 26 that is not in communication with the interior of the bladder 28.

FIG. 54 is a perspective medial side view of a shin guard 20.28 somewhat similar to that shown in FIG. 6 on a wearer 21 showing the use of several bladders 28.1, 28.2, and 28.3 containing different light cure materials 27.1 and 27.2. Bladders 28.1, 28.2, and 28.3 can be formed individually, or alternately, can be formed in a single unit having three different chambers as shown. A textile material 41 saturated with a light cure material 27.1 thereby forming an impregnated textile material 55 can be contained in bladders 28.1 and 28.3. The light cure material 27.1 used in bladders 28.1 and 28.3 can set and cure to form a relatively rigid material having a hardness equal to or greater than 75 Shore A. In contrast, the light cure material 27.2 used in bladder 28.2 can set and cure to form a relatively flexible material having a hardness less than 75 Shore A. Accordingly, a line of flexion 141 can be created as between bladders 28.1 and 28.3 due to the presence of a portion of bladder 28.2 therebetween that includes a relatively flexible light cure material 27.2. This can accommodate for flexion of a wearer's calf muscles 111 on the medial side 112, and also enhance the proper fit and retention of a shin guard 20.28 upon a wearer.

FIG. 55 is an anterior plan view of a shin guard 20.29 having an asymmetrical shape near both the superior side 109 and the inferior side 110 as between the medial side 112 and lateral side 113. Again, the asymmetrical shape shown near the superior side 109 as between the medial side 112 and lateral side 113 can possibly enhance accommodation for a wearer's calf muscles, whereas the asymmetrical shape shown near the inferior side 110 as between the medial side 112 and lateral side 113 can possibly enhance accommodation for a wearer's medial malleolus 123 and lateral malleolus 124. The anterior side 120 of the anterior most bladder 28.9 is made of a substantially transparent plastic film 26, and the bladder 28.9 can contain a light cure material 27 and a textile material 41, thus forming an impregnated textile material 55. Accordingly, the contents of bladder 28.9 can be visible from the anterior side 120, and the light cure material 27 can be caused to cure when exposed to light having a wavelength between 280 and 780 nanometers.

FIG. 56 is a posterior plan view of the shin guard including a fluid filled bladder shown in FIG. 55. The shin guard 20.29 can include a fluid filled bladder 28.10 on the posterior side 121 that includes a void 50 including a gas 51. The gas can be pressured at atmospheric pressure, or above atmospheric pressure. As shown, the fluid filled bladder 28.10 can include a weld 101 about the perimeter, but also a plurality of weld dots 142 and/or a weld line 143. The position of the weld dots 142 and/or weld line 143 can create a line of flexion 141. Further, the weld dots 142 can include an opening 49 therein for facilitating ventilation.

FIG. 57 is a transverse cross-sectional view of the shin guard 20.29 shown in FIGS. 55 and 56, taken along line 57—57 in FIG. 56. The shin guard 20.29 is shown in position on a wearer's lower leg 22. The wearer's lower leg 22 is shown in a transverse cross-sectional view generally similar to that shown in FIG. 3. As shown, the shin guard 20.29 can be made of three layers of plastic film 26 that are affixed together by conventional means such as radio frequency welding. This can sometimes be done in a single operation, or alternately, the posterior most and middle layer of plastic film can be affixed together first, and then the anterior most layer of plastic film can be subsequently affixed. Again, the anterior most bladder 28.9 can include a textile material 41 such as a woven or non-woven fiberglass

material that is impregnated with a light cure material 27 to form an impregnated textile material 55, whereas the posterior most fluid filled bladder 28.10 can include a void 50 containing a gas 51. Accordingly, when the light cure material 27 is caused to set and cure the shin guard 20.29 can provide a relatively hard medium for resisting impact events and point loads imparted to the anterior side 120, but at the same time provide a relatively soft cushioning medium capable of deflection and dampening on the posterior side 121. Moreover, as shown, the plurality of weld dots 142 and weld line 143 can also create voids 50 between the shin guard 20.29 and the wearer's 21 lower leg 22. The design and pattern of the weld dots 142 including openings 49 for ventilation and/or of the weld lines 143 can form generally longitudinal channels or ducts 144 for enhancing ventilation and dissipating both heat and humidity.

FIG. 58 is an anterior plan view of a sleeve 129 having a superior sleeve portion 130, a middle sleeve portion 131 and an inferior sleeve portion 132 for possible use with embodiments of a shin guard which do not include strap 116 fastening means such as shin guard 20.5 and shin guard 20.7 shown in FIGS. 50 and 52. For the purpose of placing a shin guard in the desired position upon a wearer when exposing the shin guard to light to cause the light cure material contained therein to set and cure, it can be advantageous for the sleeve 129 to be made of a white, translucent, or transparent textile material. In particular, the use of fine knitted synthetic textile fibers that will not substantially block or absorb an ambient or artificial light source generally similar to those used in the manufacture of women's hosiery can be advantageous for use.

FIG. 59 is a flow diagram that shows at least one method of making a custom fit shin guard 20.29 upon a wearer. At the top of FIG. 59 in the first box is shown a bottle 133 having a cap 134. The bottle 133 including the cap 134 can be made of a dark colored high density polyethylene plastic and can thereby serve as a light barrier 136 for containing and protecting a shin guard 20.29 from exposure to a source of ultraviolet and/or visible light.

In the second box from the top of FIG. 59, the bottle 133 is shown at the left having been opened and an individual's hand is shown withdrawing the shin guard 20.29.

In the third box from the top of FIG. 59 is shown an athletic sock 138, a sleeve 129, rubber bands 139, a removable strap 140 including VELCRO® hook and pile, strips of tape 137.1, and also a roll of tape 137.2. Any or all of these items can be used in partial or complete combination by an individual in order to help secure a shin guard 20.29 in functional relation upon a wearer.

In the fourth box from the top of FIG. 59 is shown a wearer applying a shin guard 20.29 to their lower leg 22 using several translucent or substantially transparent rubber bands 139 in order to temporarily hold the shin guard 20.29 in position.

In the fifth box from the top of FIG. 59 is shown a wearer applying a sleeve 129 to their lower leg 32 over a shin guard 20.29. The shin guard 20.29 is being temporarily held in place using several translucent or substantially transparent rubber bands 139 in order to hold the shin guard 20.29 in position.

FIG. 60 is another flow diagram that shows at least one method of making a custom fit shin guard 20.29 upon a wearer 21. At the top of FIG. 60 in the first box is shown the alternate use of a bag 135 which serves as a light barrier 136 for containing and protecting a shin guard 20.29 from exposure to a source of ultraviolet and/or visible light. The

bag **135** can include a thermoplastic film including leafing grade aluminum flakes, and the like, in order to create a light barrier **136** generally similar to those known in the packaging industry with respect to food preservation and also the protection of photographic film.

In the second box from the top of FIG. **60**, the bag **135** is shown at the right having been opened and an individual's hand is shown withdrawing the shin guard **20.29**.

In the third box from the top of FIG. **60** is shown an athletic sock **138**, a sleeve **129**, rubber bands **139**, a removable strap **140** including VELCRO® hook and pile, strips of tape **137.1**, and also a roll of tape **137.2**. Any or all of these items can be used in partial or complete combination by an individual in order to secure a shin guard **20.29** in functional relation upon a wearer.

In the fourth box from the top of FIG. **60** is shown a wearer applying a shin guard **20.29** to their lower leg **22** using several strips of substantially transparent tape **137.1** in order to temporarily affix the shin guard **20.29** in position to the wearer's athletic sock **138**.

In the fifth box from the top of FIG. **60** is shown a wearer applying a sleeve **129** to their lower leg **32** over a shin guard **20.29**. The shin guard **20.29** is also being temporarily held in place using several strips of substantially transparent tape **137.1** that are affixed to the wearer's athletic sock **138** in order to hold the shin guard **20.29** in position.

It can be readily understood that the materials, structures, articles, and methods disclosed or recited herein, and their equivalents, can be used various combinations. Accordingly, while the above detailed description of the invention contains many specificities, these should not be construed as limitations on the scope of the invention, but rather as exemplifications of several preferred embodiments thereof. Many other variations are possible. Accordingly, the scope of the invention should be determined not by the embodiments discussed or illustrated, but by the appended claims and their legal equivalents.

I claim:

**1.** A shin-guard for protecting a portion of a wearer's anatomy comprising a superior side, inferior side, medial side, lateral side, anterior side, and posterior side, comprising a bladder containing a textile material impregnated with a light cure material which can be caused to set and cure when exposed to light having a wavelength in the range between 280–780 nanometers.

**2.** The shin-guard according to claim **1**, wherein said textile material comprises a fiberglass material.

**3.** The shin-guard according to claim **1**, wherein said shin-guard comprises an asymmetrical shape as between said medial side and said lateral side.

**4.** The shin-guard according to claim **1**, wherein said shin-guard comprises a superior guard portion for protecting said wearer's lower leg including a first strap near said superior side for affixing about said wearer's lower leg, and an inferior guard portion for protecting said wearer's medial and lateral malleoli including a second strap for affixing under the plantar side of said wearer's foot.

**5.** The shin-guard according to claim **4**, wherein said superior guard portion, and said inferior guard portion are detachable.

**6.** The shin-guard according to claim **1**, further comprising a posterior guard.

**7.** The shin-guard according to claim **1**, further comprising a flex notch on said medial side.

**8.** The shin-guard according to claim **1**, further comprising a first strap near said superior side, and a second strap near said inferior side.

**9.** The shin-guard according to claim **1**, further comprising a reflective material.

**10.** The shin-guard according to claim **1**, further comprising a plurality of openings for ventilation.

**11.** The shin-guard according to claim **1**, further comprising a foam material.

**12.** The shin-guard according to claim **11**, wherein said foam material is impregnated with said light cure material.

**13.** The shin-guard according to claim **11**, wherein said foam material comprises peaks and valleys.

**14.** The shin-guard according to claim **11**, wherein said bladder is affixed in functional relation to said foam material, and said bladder substantially comprises said anterior side and said foam material substantially comprises said posterior side of said shin-guard.

**15.** The shin-guard according to claim **1**, further including a void comprising a gas.

**16.** The shin-guard according to claim **1**, further comprising an anterior bladder and a posterior bladder configured in an overlapping relationship.

**17.** The shin-guard according to claim **1**, further comprising at least two bladders configured in a side-by-side relationship.

**18.** The shin-guard according to claim **1**, further comprising channels for ventilation.

**19.** A shin-guard for protecting a portion of a wearer's anatomy comprising a superior side, inferior side, medial side, lateral side, anterior side, and posterior side, comprising three layers of plastic film affixed together in functional relation thereby forming an anterior bladder and a posterior bladder, said anterior bladder including a textile material impregnated with a light cure material which can be caused to set and cure when exposed to light having a wavelength in the range between 280–780 nanometers, and said posterior bladder including a void comprising a gas.

**20.** A method of making a shin-guard having a superior side, inferior side, medial side, lateral side, anterior side, and posterior side, comprising a bladder containing a textile material impregnated with a light cure material which can be caused to set and cure when exposed to light having a wavelength in the range between 280–780 nanometers comprising:

- a) Opening a container which is substantially impenetrable to said light and removing said shin-guard;
- b) Placing said shin-guard in position upon a wearer; and,
- c) Exposing said shin-guard to said light causing said light cure material to cure.

\* \* \* \* \*