



US006672532B1

(12) **United States Patent**  
**Huang**

(10) **Patent No.:** **US 6,672,532 B1**  
(45) **Date of Patent:** **Jan. 6, 2004**

(54) **APPARATUS OF TAPE DISPENSER TO PREVENT TAPE ROLL ROTATING BACKWARDS**

4,358,328 A \* 11/1982 Pearson ..... 225/65  
4,961,525 A \* 10/1990 Corbo et al. .... 225/65  
4,998,655 A \* 3/1991 Huang ..... 225/47  
5,820,005 A \* 10/1998 Perkitny et al. .... 225/65  
6,216,978 B1 \* 4/2001 Rodriguez ..... 242/588.6

(76) **Inventor:** **Harrison Huang**, No. 23, Lin T'So Rd., Sheng Kang Hsian, Taichung Hsien (TW)

\* cited by examiner

(\* ) **Notice:** Subject to any disclaimer, the term of this patent is extended or adjusted under 35 U.S.C. 154(b) by 0 days.

*Primary Examiner*—William A. Rivera  
(74) *Attorney, Agent, or Firm*—Bacon & Thomas, PLLC

(21) **Appl. No.:** **10/225,164**

(22) **Filed:** **Aug. 22, 2002**

(51) **Int. Cl.**<sup>7</sup> ..... **B65H 16/06; B65H 35/07**

(52) **U.S. Cl.** ..... **242/588.6; 225/65; 225/66**

(58) **Field of Search** ..... 242/588, 580, 242/588.3, 588.6, 402, 405, 422.4; 225/56, 57, 58, 59, 77, 61, 62, 65, 66, 47; 206/409, 408, 411

(57) **ABSTRACT**

A tape dispenser. The dispenser includes a main body having a connecting board, two side arms at opposite ends of the connecting board respectively, two roll mounts at interior sides of the side arms respectively, four guiding pieces at interior sides of the side arms and below the connecting board and a cutting portion at exterior side of the side arm. A tape roll can be installed at between the side arms by inserting the roll mounts into a central hole of the tape roll. Each roll mount is provided with two stop arms extended substantially parallel to the rotating axis of the tape roll, which has a free end and a block on the exterior side thereof. The blocks are pressed by the tape roll to make the stop arms bent so that they will provide a friction to the tape roll, and a cutter is mounted on the connecting board for cutting a tape of the tape roll off.

(56) **References Cited**

**U.S. PATENT DOCUMENTS**

2,664,252 A \* 12/1953 Glew ..... 225/66  
2,731,084 A \* 1/1956 Burns ..... 225/65  
3,155,301 A \* 11/1964 Kusek ..... 225/66  
3,173,591 A \* 3/1965 Sax et al. .... 225/66

**12 Claims, 5 Drawing Sheets**

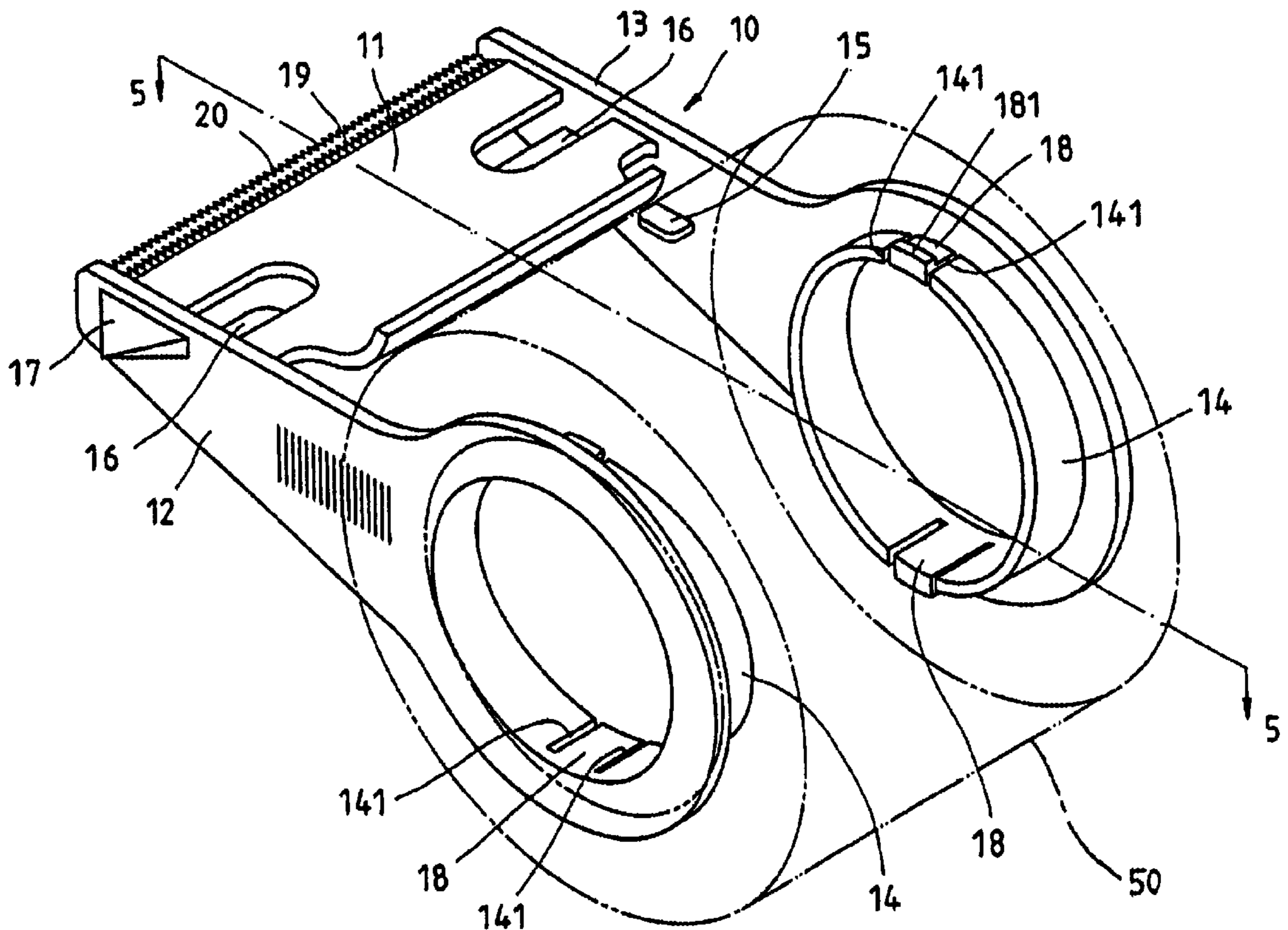

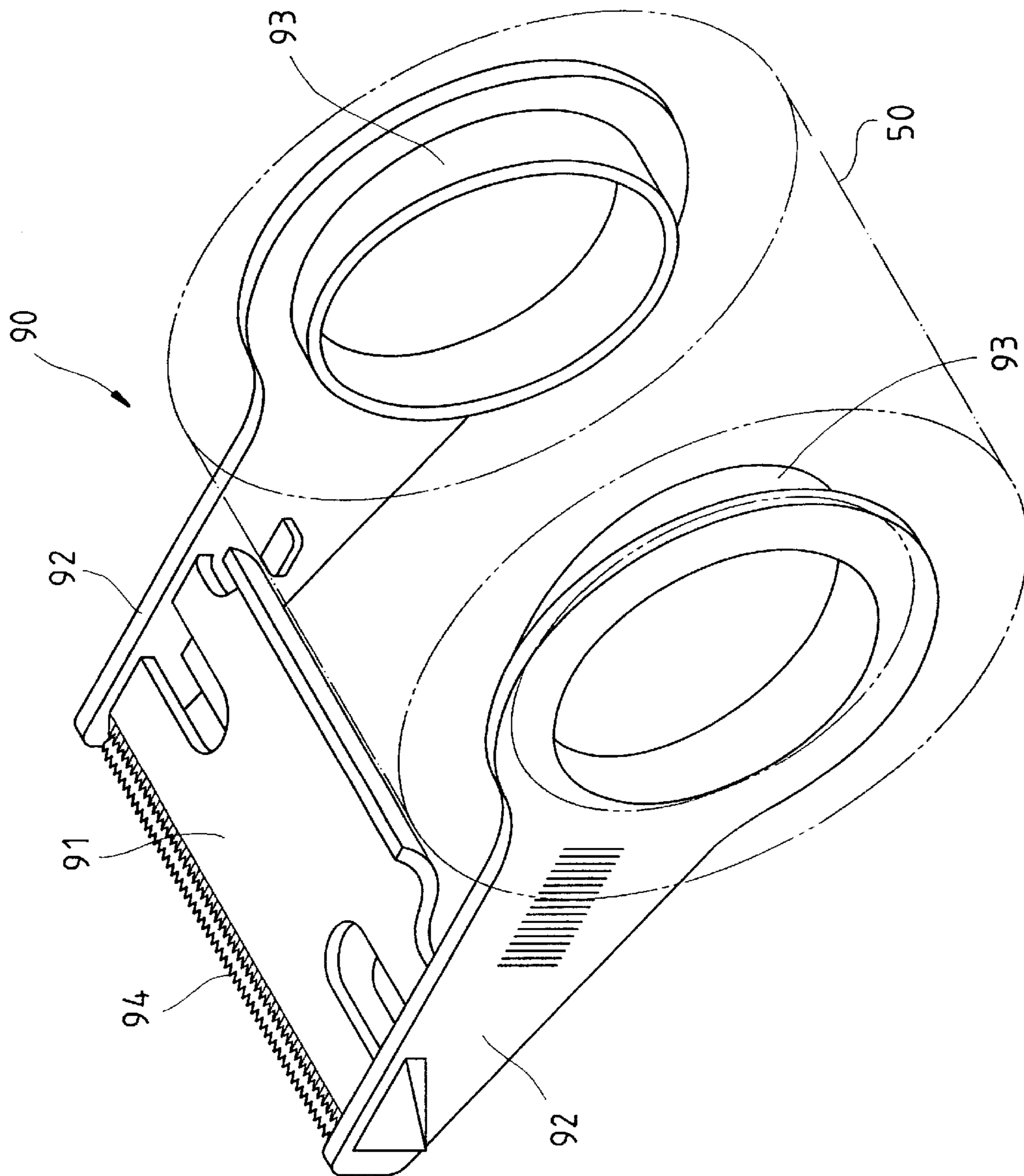

FIG. 1  
PRIOR ART

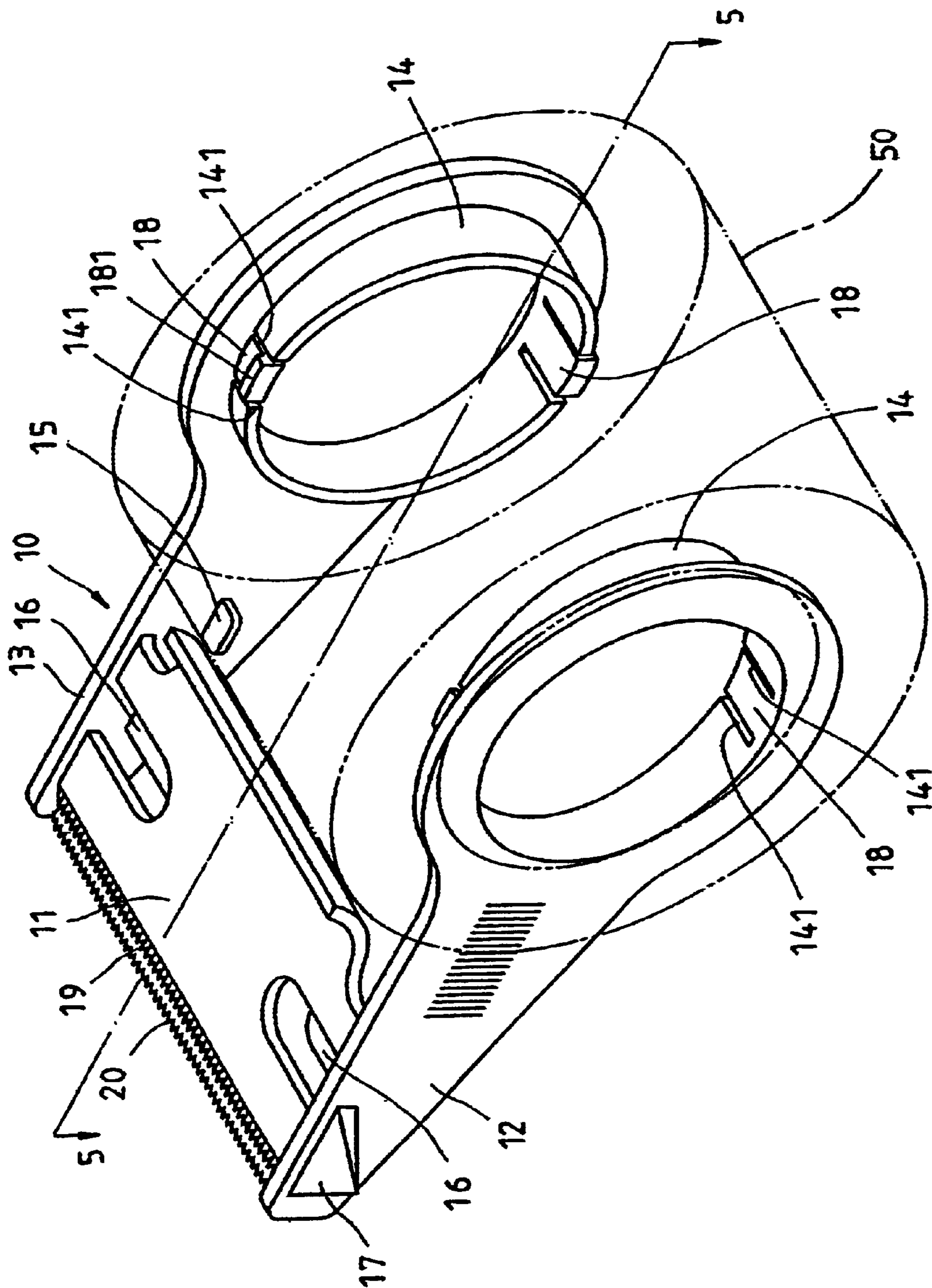

FIG. 2

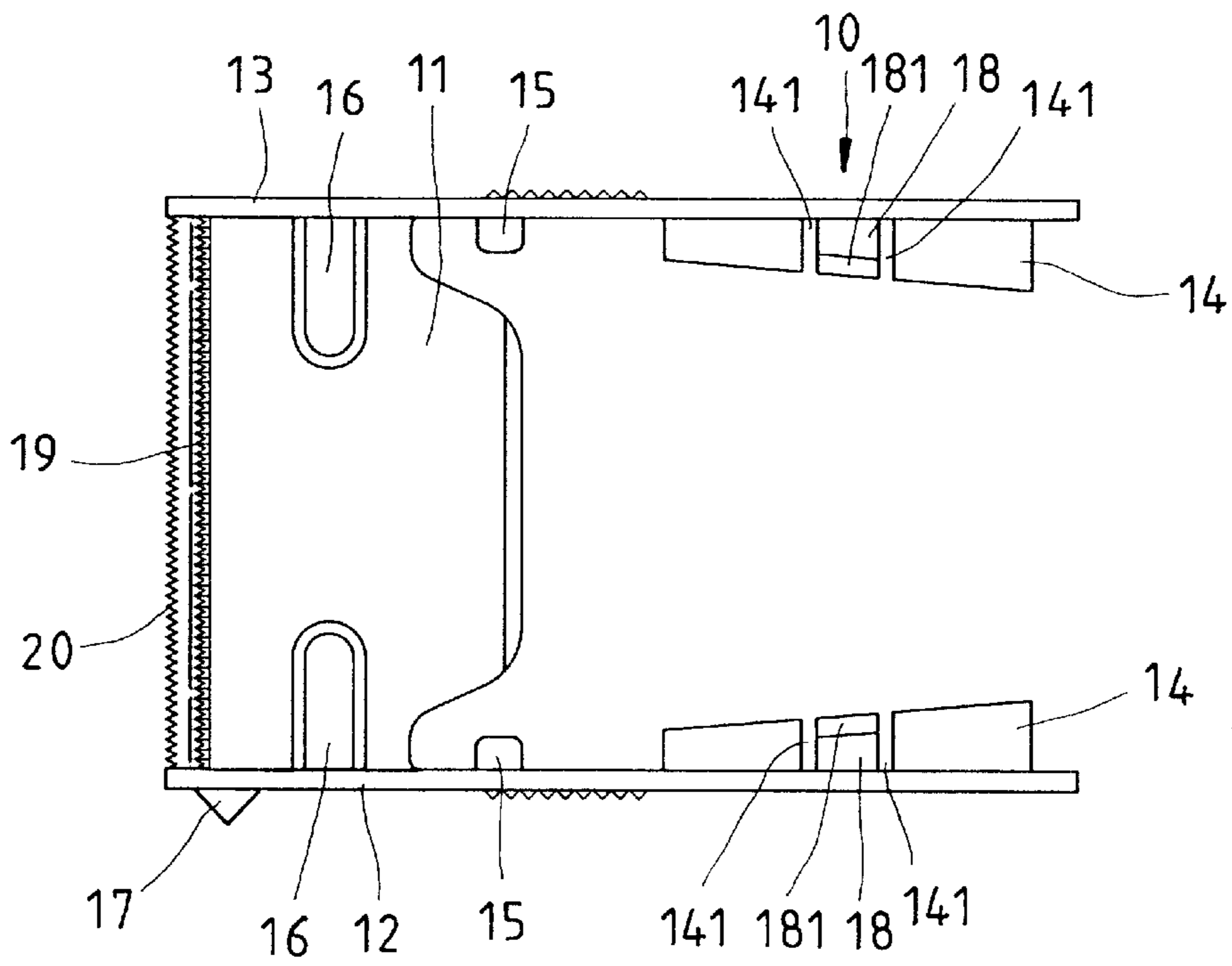

FIG. 3

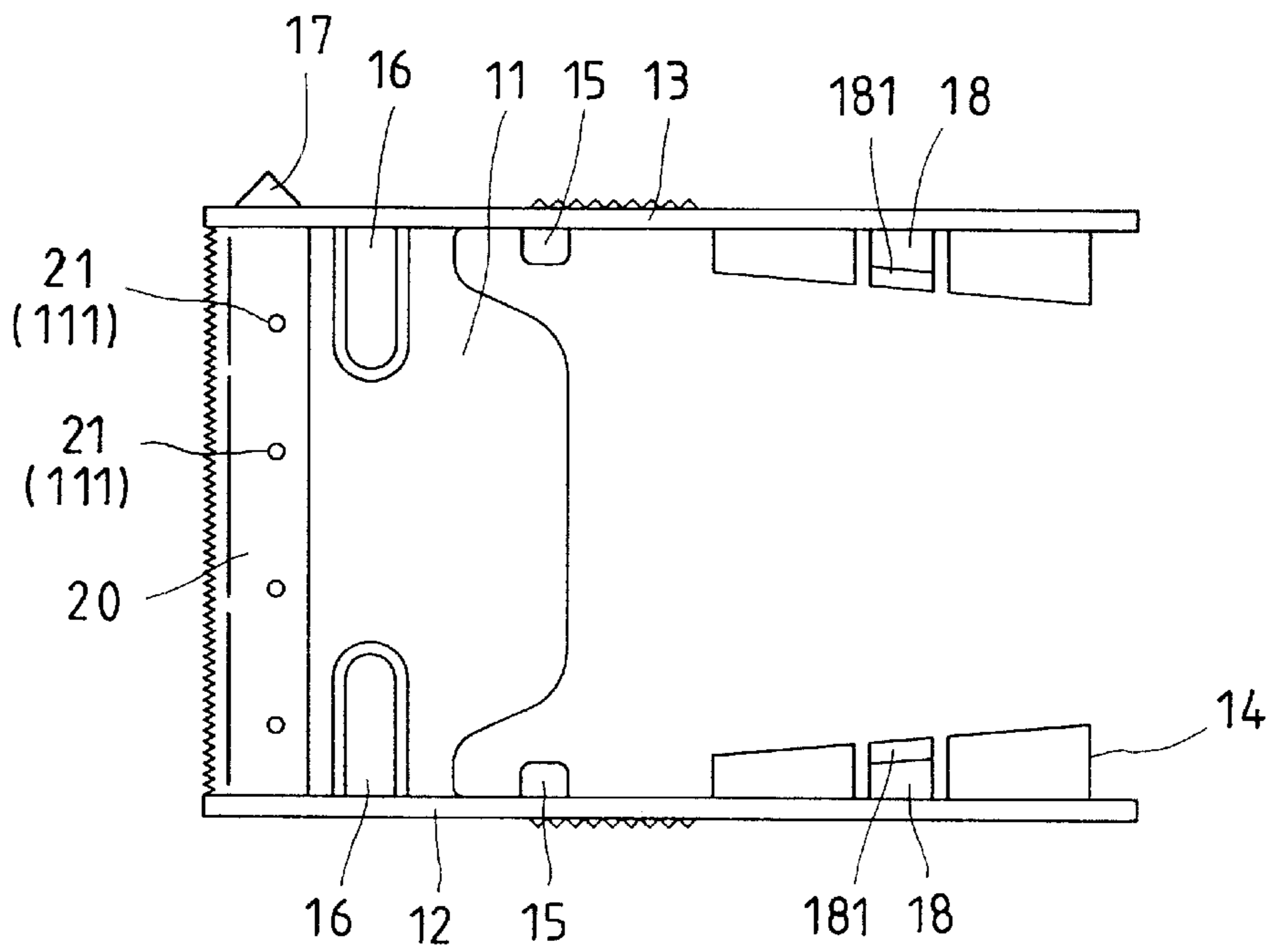

FIG. 4

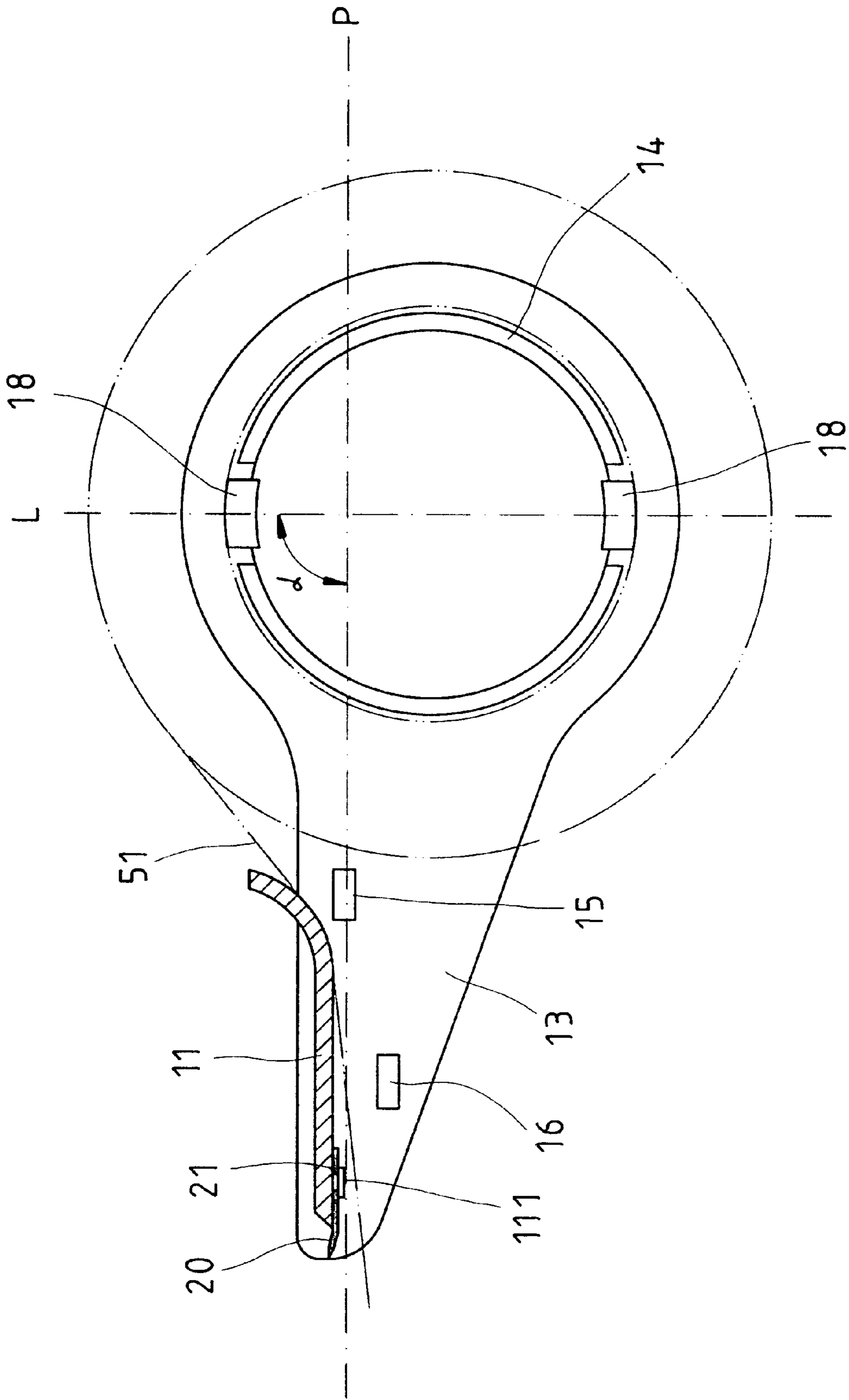

FIG. 5

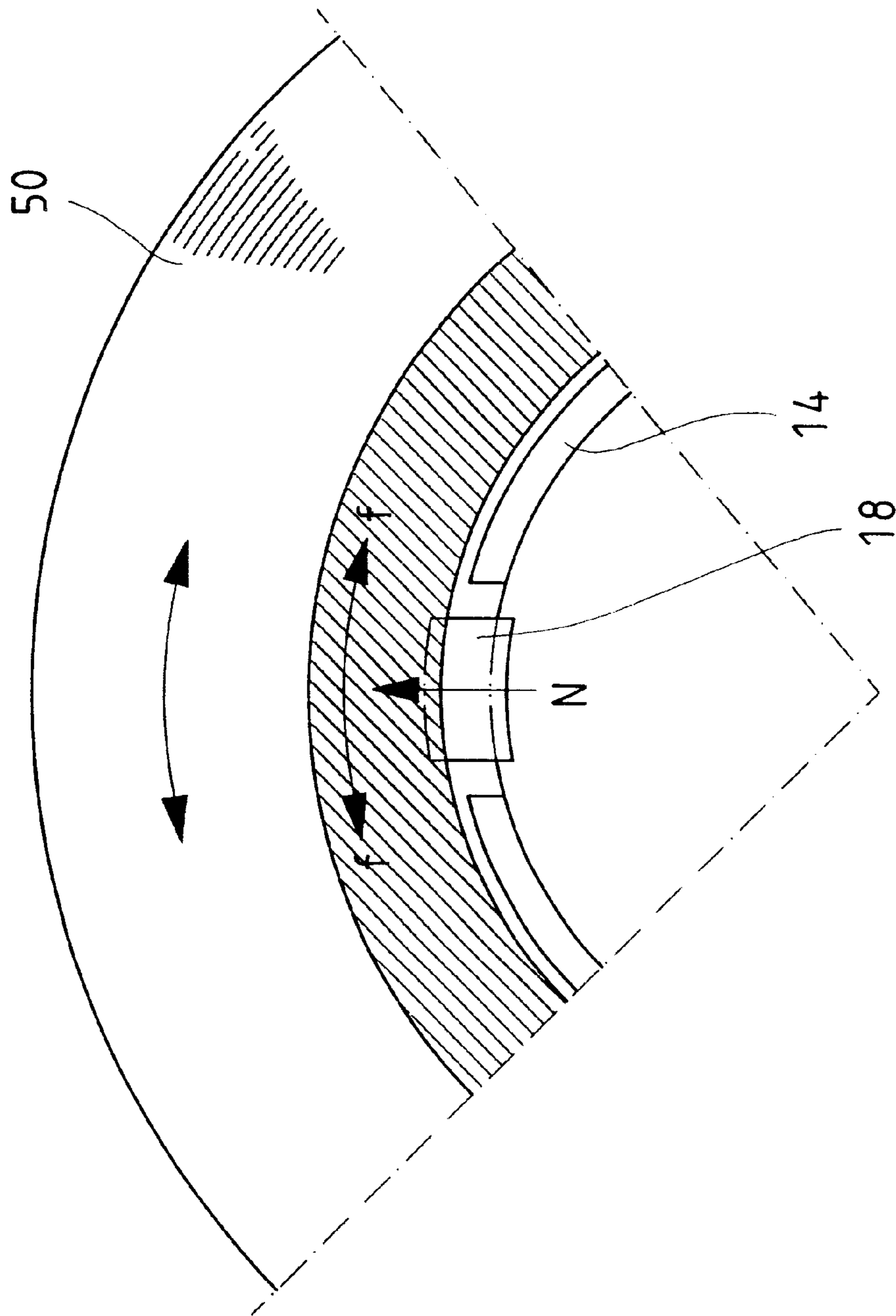

FIG. 6

## APPARATUS OF TAPE DISPENSER TO PREVENT TAPE ROLL ROTATING BACKWARDS

### FIELD OF THE INVENTION

The present invention relates to a packing tool, and more particularly to a tape dispenser, which can prevent tape roll rotating backwards.

### BACKGROUND OF THE INVENTION

FIG. 1 shows a conventional tape dispenser **90** mainly comprising a connecting board **91**, two side arms **92** at the opposite ends of the connecting board **91**, two annular roll mounts **93** at the interior sides of the side arms **92** respectively and a cutter **94** at front end of the connecting board **91**.

In use, a tape roll **50** is installed to the tape dispenser **90** between the side arms **92** with the roll mounts **93** inserted into the opposite ends of a central hole of the tape roll **50** for free rotation. The tape of the tape roll **50** is drawn out to the front side of the connecting board **91** to adhere to something and the cutter **94** can be used to cut the tape off.

Sometimes when the cutter **94** cuts the tape off, tension of the tape will make the tape roll **50** rotate backwards and cause the tail of the tape to run back on the tape roll **50**. The tape roll **50** may also rotate backwards because of its own weight or by an unexpected force. These events cause inconvenience to the user when the tape dispenser is next used.

### SUMMARY OF THE INVENTION

The primary object of the present invention is to provide a tape dispenser, which can prevent tape roll rotating backwards in unexpected situation to draw the tape back.

According to the object of the present invention, a tape dispenser comprises a main body having a connecting board, two side arms at opposite ends of the connecting board respectively and two roll mounts at interior sides of the side arms respectively for installing a tape roll between the side arms and inserting the roll mounts into a central hole of the tape roll. The roll mount is provided with at least a stop arm extended substantially parallel to the rotating axis of the tape roll, which has a free end to be pressed by the tape roll to provide a friction to the tape roll, and a cutting means for cutting a tape of the tape roll off.

### BRIEF DESCRIPTION OF THE DRAWINGS

FIG. 1 is a perspective view of a conventional tape dispenser;

FIG. 2 is a perspective view of a preferred embodiment of the present invention;

FIG. 3 is a top view of the preferred embodiment of the present invention;

FIG. 4 is a bottom view of the preferred embodiment of the present invention;

FIG. 5 is a sectional view taken along line 5—5 in FIG. 2, and

FIG. 6 is an enlarged view in part of FIG. 5.

### DETAIL DESCRIPTION OF THE INVENTION

Please refer to FIGS. 2–5, the preferred embodiment of the present invention provides a tape dispenser **10**, which comprises a main body **10** made from plastics injection

molding and having a connecting board **11**, two side arms **12** and **13**, two roll mounts **14**, four guiding pieces **15** and **16** and a cutting portion **17**.

The side arms **12** and **13** are connected with the connecting board **11** at its opposite ends respectively. The side arms **12** and **13** are flexible to bend their back ends. The roll mounts **14** are annular ribs disposed at the interior sides of the side arms **12** and **13** respectively to install a tape roll **50** thereon. The guiding pieces **15** and **16** are disposed at the interior sides of the side arms **12** and **13** below the connecting board **11**. The cutting portion **17** is a triangular piece to cut the package off.

Each of the roll mounts **12** and **13** has two stop arms **18** parallel to the rotating axis of the tape roll **50**. The stop arms **18** are made from disposing gaps **141** on the roll mounts **12** and **13** to form the stop arm **18** between two gaps **141** so that each stop arm **18** has a free end and is flexible. Each stop arm **18** has a block **181** at the exterior side and closing to the free end thereof.

A cutter **20** is mounted on the connecting board **11**. The cutter is a metal piece in the present preferred embodiment having a saw edge. The connecting board **11** is disposed with pins **111** to be inserted into openings **21** on the cutter **20**. Hot pressing the pins **111** to deform them and the pins **111** can secure the cutter **20** on the connecting board **11**.

In use, please refer to FIG. 2, a tape roll **50** is installed between the side arms and insert the roll mounts **14** into the central hole of the tape roll **50** such that tape **51** of the tape roll can be drawn out to run through a tunnel between the guiding pieces **15** and **16** and the connecting board **11** and extrude out of the cutter **20**.

Please refer to FIGS. 2 and 6, wherein the tape roll **50** mounted on the tape dispenser of the present invention will press the blocks **181** to make the stop arms **18** bent. A normal force  $N$  occurs between the stop arms **18** and the tape roll **50** such that it will provide a friction  $f$ . User has to exert the tail of the tape **51** to overcome the friction  $f$ , thus, he/she can draw the tape **51** out. As shown in at least FIG. 6, the stop arm **18** has a free end (block **181**) that presses the tape roll **50** with an elastic normal force  $N$  that is substantially perpendicular to the rotating axis of the tape roll **50** to provide friction to the tape roll **50**.

The friction  $f$ , however, also will stop the tape roll **50** running backwards under the unexpected situations, such as the tension of the tape **51** when it is cut off, the weight of the tape roll **50** or exerted by exterior force which will make the tape roll **50** running backwards. Such that the tail of the tape **51** will stay on connecting board **11** to facilitate next time use.

The strength of the friction  $f$  provided by the stop arms **18** is depended on several factors, such as the size, material and numbers of the stop arms **18** and the height of the blocks **181**. The friction  $f$  can not too strong, it will make the tape **51** hard to be drawn out. But, if the friction  $f$  is weak, the tape roll **50** still has chance to run backwards unexpectedly.

The locations of the stop arms **18** have better place to be disposed. Please refer to FIG. 5 line  $L$  is a line passing through the stop arm **18** and the center of the roll mount **14** and line  $P$  is a line parallel to the plane of the connecting board **11**. The included angle  $\alpha$  of the line  $L$  and line  $P$  is better within a range of 45 degrees to 135 degrees. The stop arms **18** of the present invention are located at the positions where the angle  $\alpha$  is 90 degrees. If the stop arms **18** are located at the position out of the range, the tape roll might be self-locked when draw the tape **181** out.

It also can be just disposed with a saw portion **19** at the front edge of the connecting board **11** to replace the cutter **20** to cut the tape **51** off.

3

What is claimed is:

1. A tape dispenser, comprising:

a main body having a connecting board, two side arms at opposite ends of said connecting board respectively and two roll mounts at interior sides of said side arms respectively for installing a tape roll between said side arms and inserting said roll mounts into a central hole of the tape roll;

said roll mounts provided with at least a stop arm extended substantially parallel to the rotating axis of the tape roll mounted to said roll mounts, said stop arm has a free end that presses the tape roll with an elastic normal force that is substantially perpendicular to the rotating axis of the tape roll to provide friction to the tape roll; and

a cutter for cutting a tape of the tape roll.

2. A tape dispenser as claimed in claim 1, wherein said stop arm is provided with a block.

3. The tape dispenser as claimed in claim 1, wherein said cutter is mounted on said connecting board to cut the tape of the tape roll.

4. The tape dispenser as claimed in claim 3, wherein said connecting board is provided with pins to insert them into openings on said cutter, and distal ends of said pins are deformed to secure said cutter on said connecting board.

5. The tape dispenser as claimed in claim 1, wherein an included angle between the line passing through said stop arm at the center of said roll mount and a plane parallel to said connecting board is within a range of 45 degrees to 135 degrees.

6. The tape dispenser as claimed in claim 5, wherein said included angle is about 90 degrees.

4

7. A tape dispenser comprising:

a main body having a connecting board, two side arms at opposite ends of said connecting board respectively and two roll mounts at interior sides of said side arms respectively for installing a tape roll between said side arms and inserting said roll mounts into a central hole of the tape roll;

said roll mounts provided with at least a stop arm extended substantially parallel to the rotating axis of the tape roll, which has a free end to be pressed by the tape roll to provide a friction to the tape roll;

a cutter for cutting a tape of the tape roll; and

wherein said roll mount is provided with gaps, said stop arm is formed at between two of said gaps.

8. The tape dispenser as claimed in claim 7, wherein said stop arm is provided with a block.

9. The tape dispenser as claimed in claim 7, wherein said cutter is mounted on said connecting board to cut the tape of the tape roll off.

10. The tape dispenser as claimed in claim 9, wherein said connecting board is provided with pins to insert them into openings on said cutter, and distal ends of said pins are deformed to secure said cutter on said connecting board.

11. The tape dispenser as claimed in claim 7, wherein an included angle between a line passing through said stop arm and the center of said roll mount and a plane parallel to said connecting board is within a range of 45 degrees to 135 degrees.

12. The tape dispenser as claimed in claim 11, wherein said included angle is about 90 degrees.

\* \* \* \* \*