



US006644302B1

(12) **United States Patent**
Bartley

(10) **Patent No.:** **US 6,644,302 B1**
(45) **Date of Patent:** ***Nov. 11, 2003**

(54) **OVEN RACK**

(75) Inventor: **Robert J. Bartley**, Stevensville, MT (US)

(73) Assignee: **Barson Enterprises, Inc.**, Stevensville, MT (US)

(*) Notice: Subject to any disclaimer, the term of this patent is extended or adjusted under 35 U.S.C. 154(b) by 35 days.

This patent is subject to a terminal disclaimer.

(21) Appl. No.: **09/782,232**

(22) Filed: **Feb. 12, 2001**

Related U.S. Application Data

(63) Continuation-in-part of application No. 09/567,662, filed on May 9, 2000, now Pat. No. 6,205,997.

(51) **Int. Cl.**⁷ **F24C 15/16**

(52) **U.S. Cl.** **126/337 R; 211/181.1; 211/153**

(58) **Field of Search** 126/337 R, 332, 126/333, 337 A, 338, 339; 211/181.1, 153, 134; 312/280, 281, 351, 410

(56) **References Cited**

U.S. PATENT DOCUMENTS

737,671 A * 9/1903 Spicer 126/332

1,350,330 A	8/1920	Partonnar	126/338
1,398,725 A	* 11/1921	Kneier	126/337 R
1,941,301 A	12/1933	Hanson et al.	126/339
1,997,432 A	* 4/1935	Replogle	126/337 R
2,189,240 A	* 2/1940	Burr	126/337 R
2,751,486 A	* 6/1956	Evans	126/337 R
2,806,467 A	9/1957	Slaughter	126/337 R
3,450,025 A	* 6/1969	Fleming	126/337 R
4,476,848 A	* 10/1984	Protas	126/337 R
5,447,146 A	9/1995	Nickerson	126/339
5,938,968 A	8/1999	Ogg et al.	126/339
6,205,997 B1	* 3/2001	Bartley	126/337 R

FOREIGN PATENT DOCUMENTS

FR	1016946	11/1952
GB	15228 A	* of 1915
GB	827796	2/1960
JP	10-238964 A	* 9/1998

* cited by examiner

Primary Examiner—Josiah Cocks

(74) *Attorney, Agent, or Firm*—Saliwanchik, Lloyd & Saliwanchik

(57) **ABSTRACT**

An oven rack has a notch along its periphery. Flat items placed on the rack traversing the notch can be easily removed from the oven without having to first slide the rack from the oven. A handle can be included on the rack to assist in pulling the rack from the oven, if desired.

15 Claims, 9 Drawing Sheets

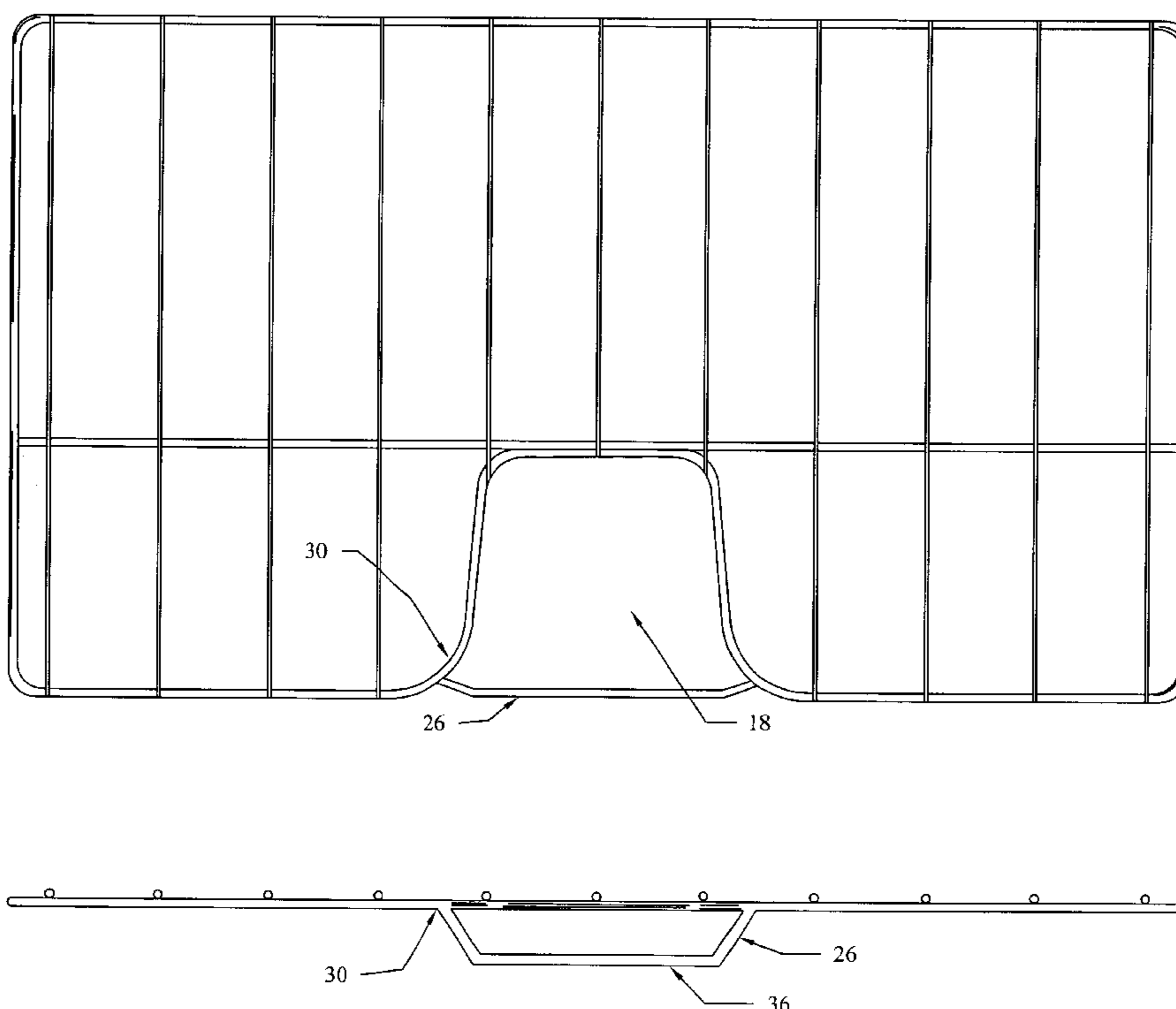

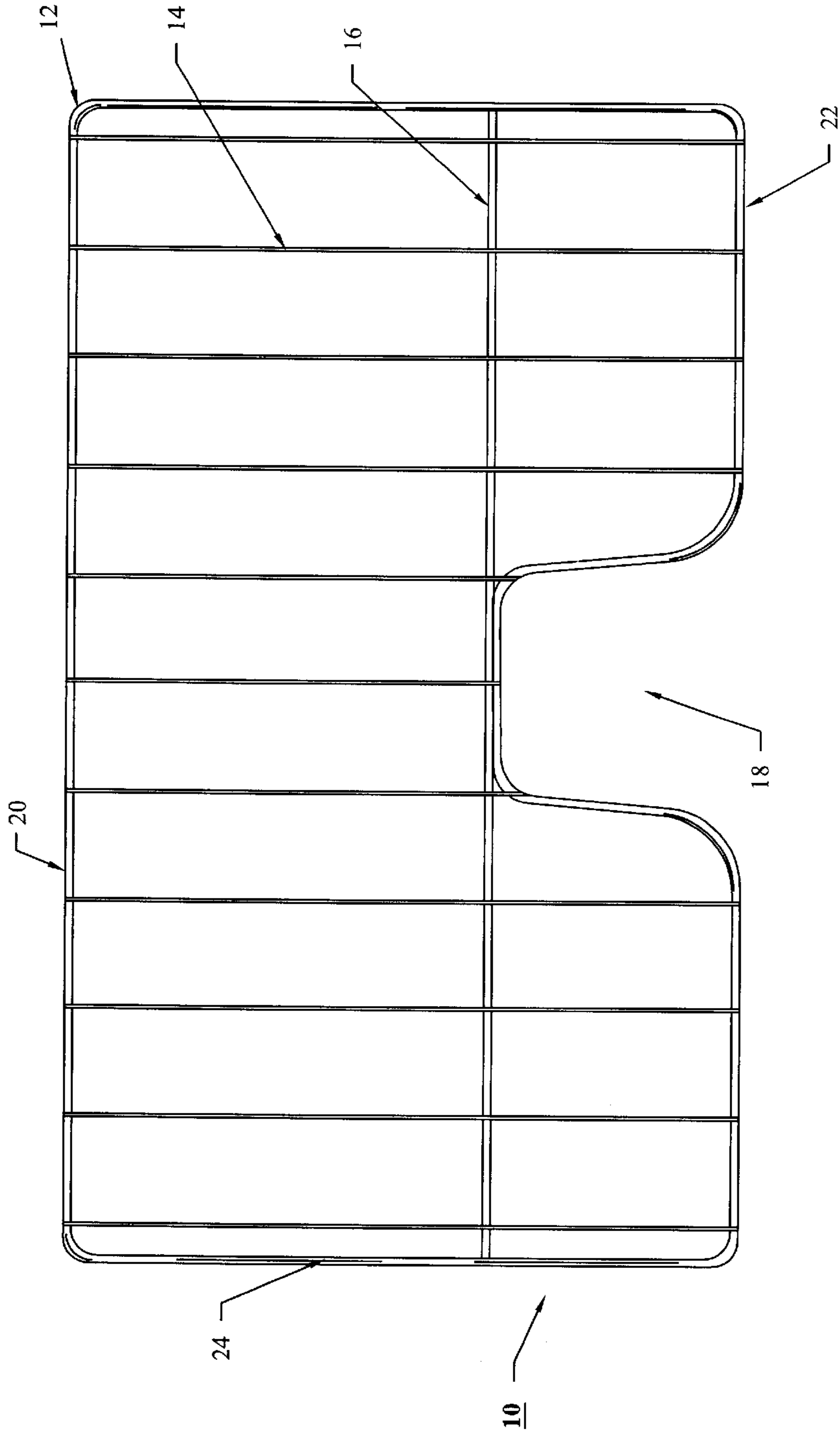

FIG. 1A



FIG. 1B

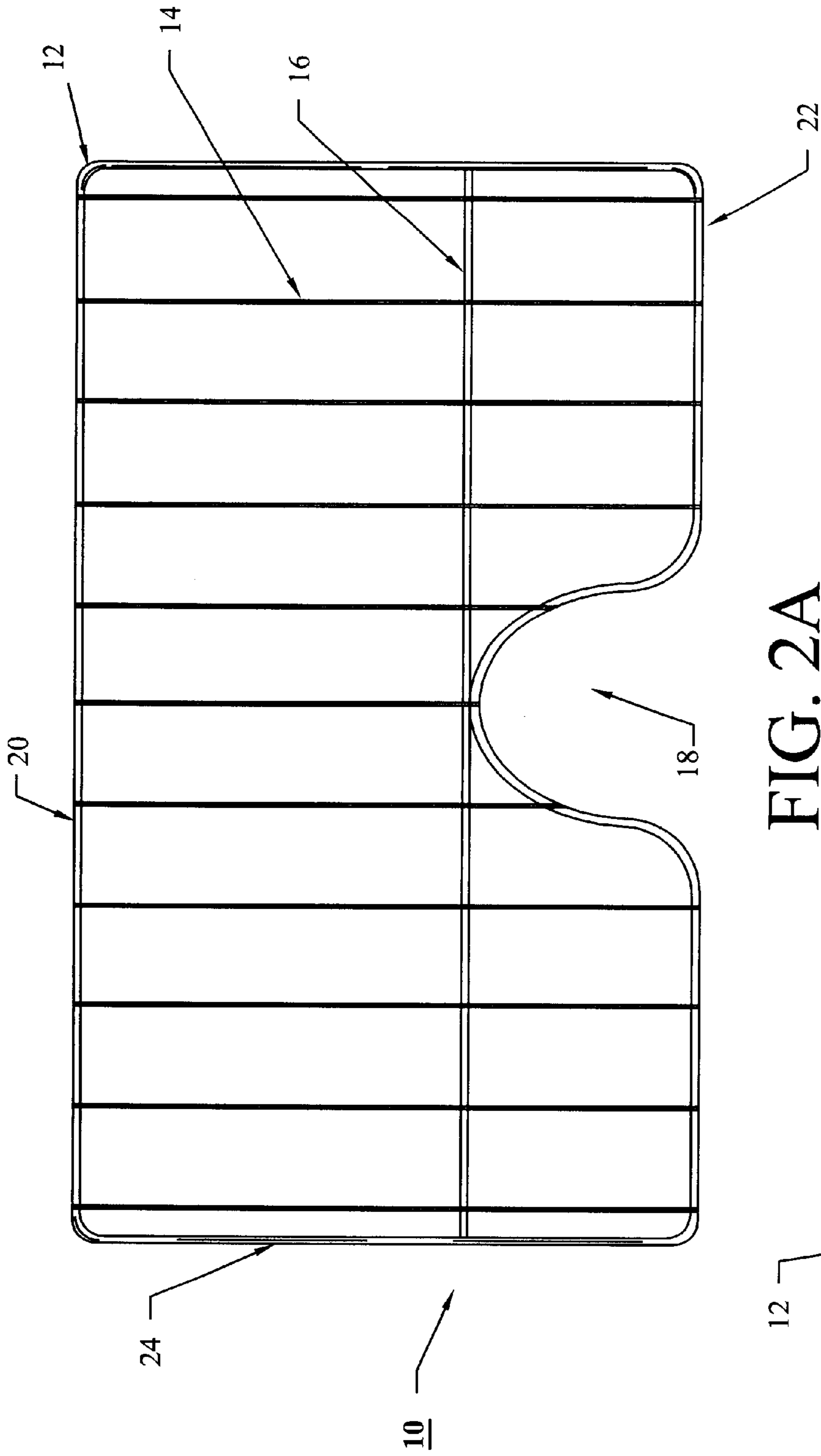

FIG. 2A



FIG. 2B

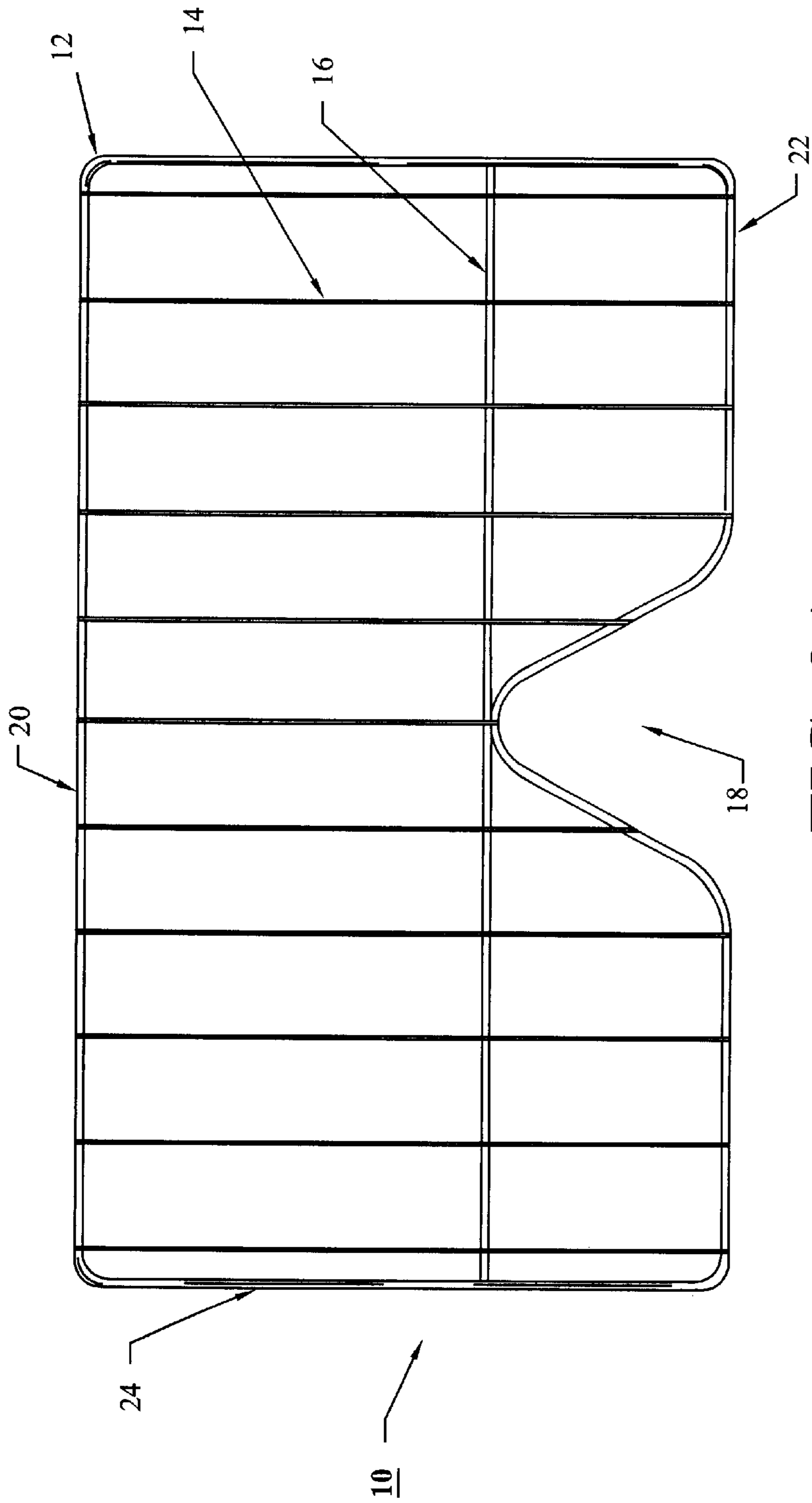

FIG. 3A



FIG. 3B

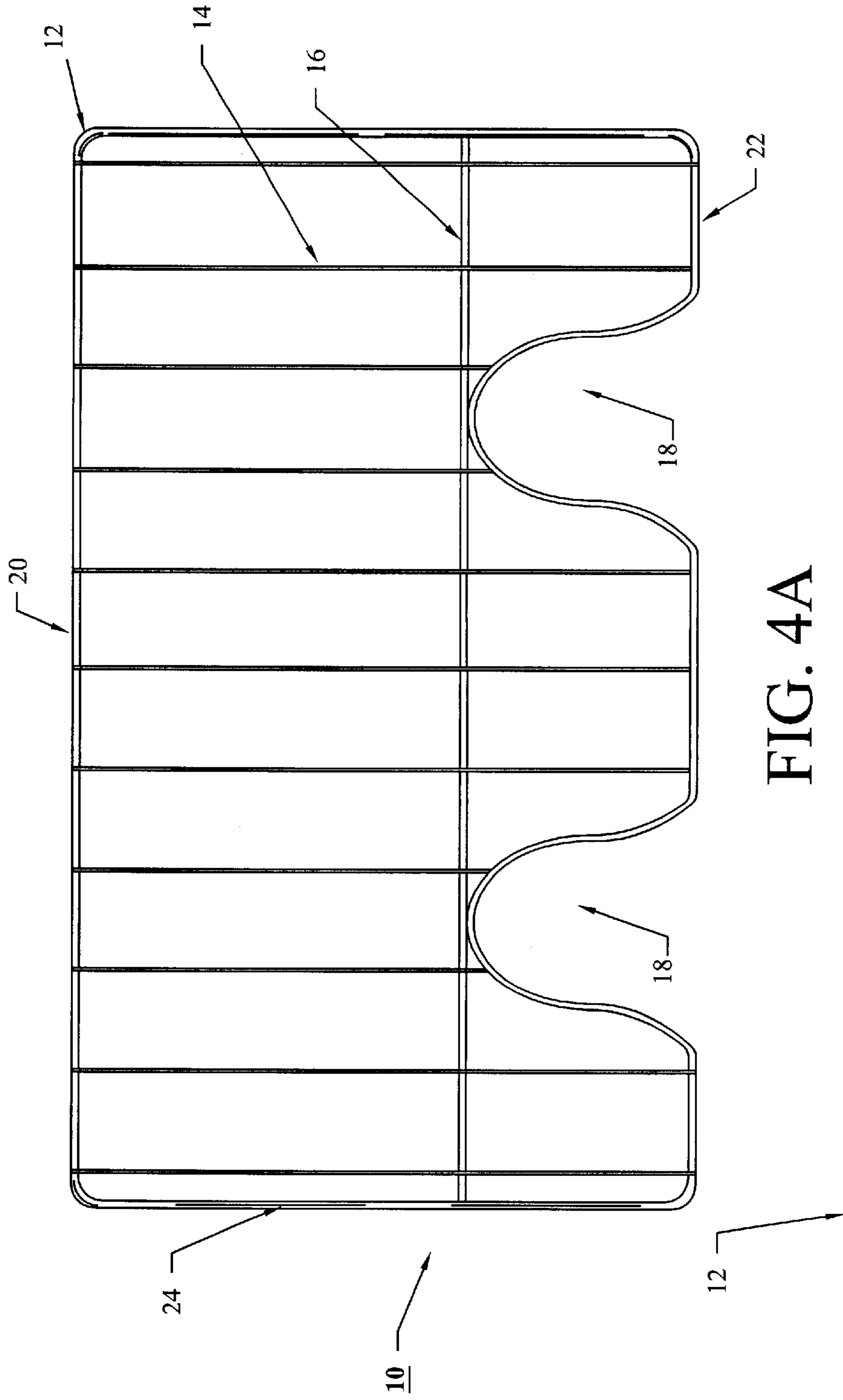

FIG. 4A

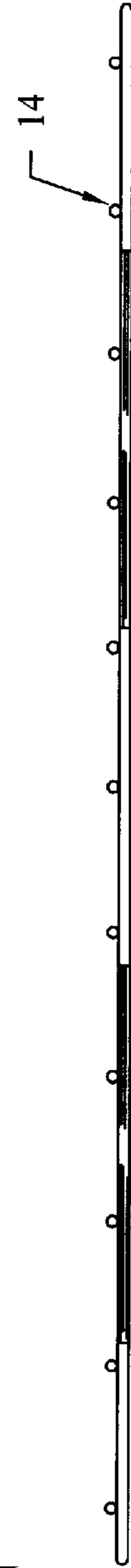

FIG. 4B

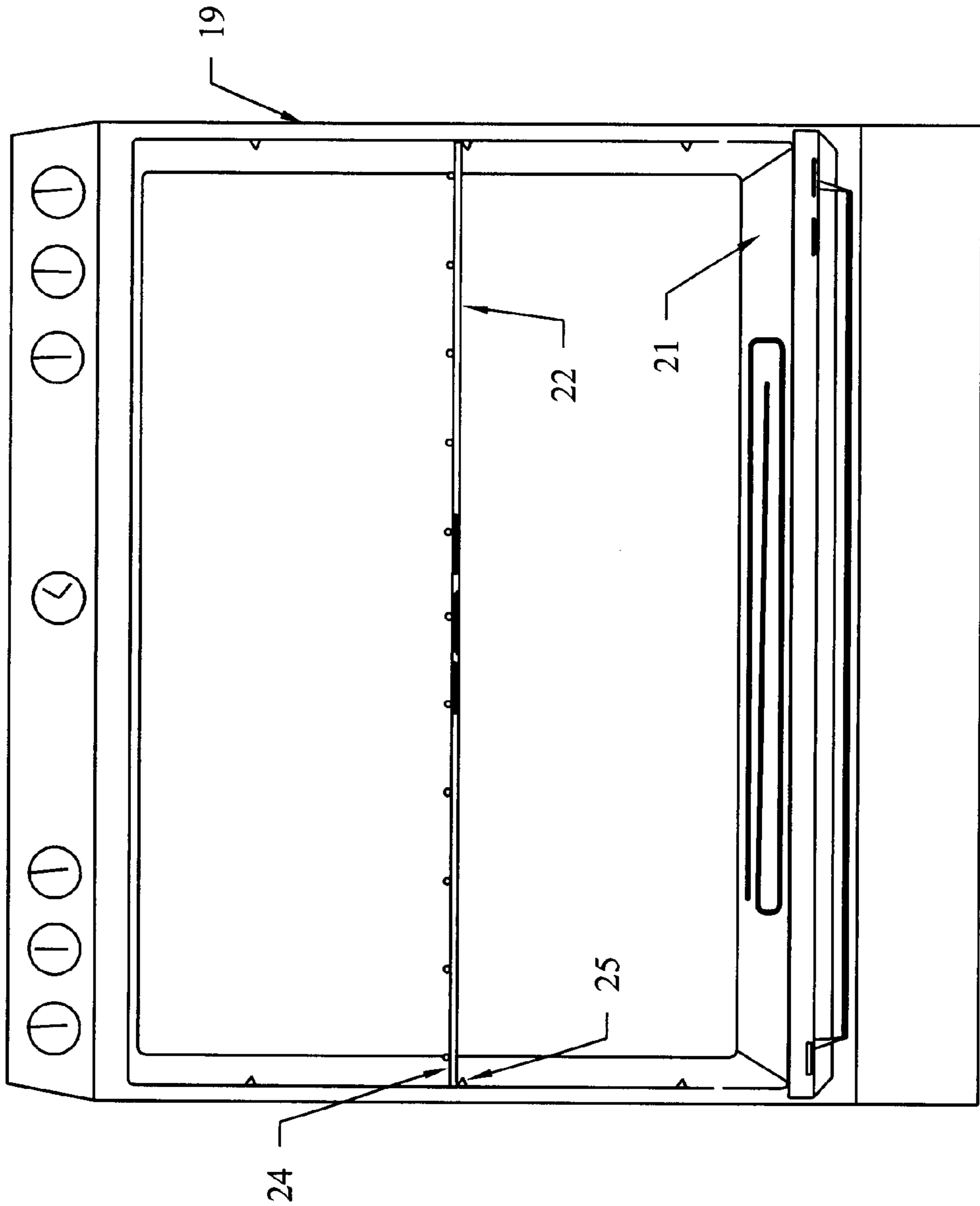

FIG. 5

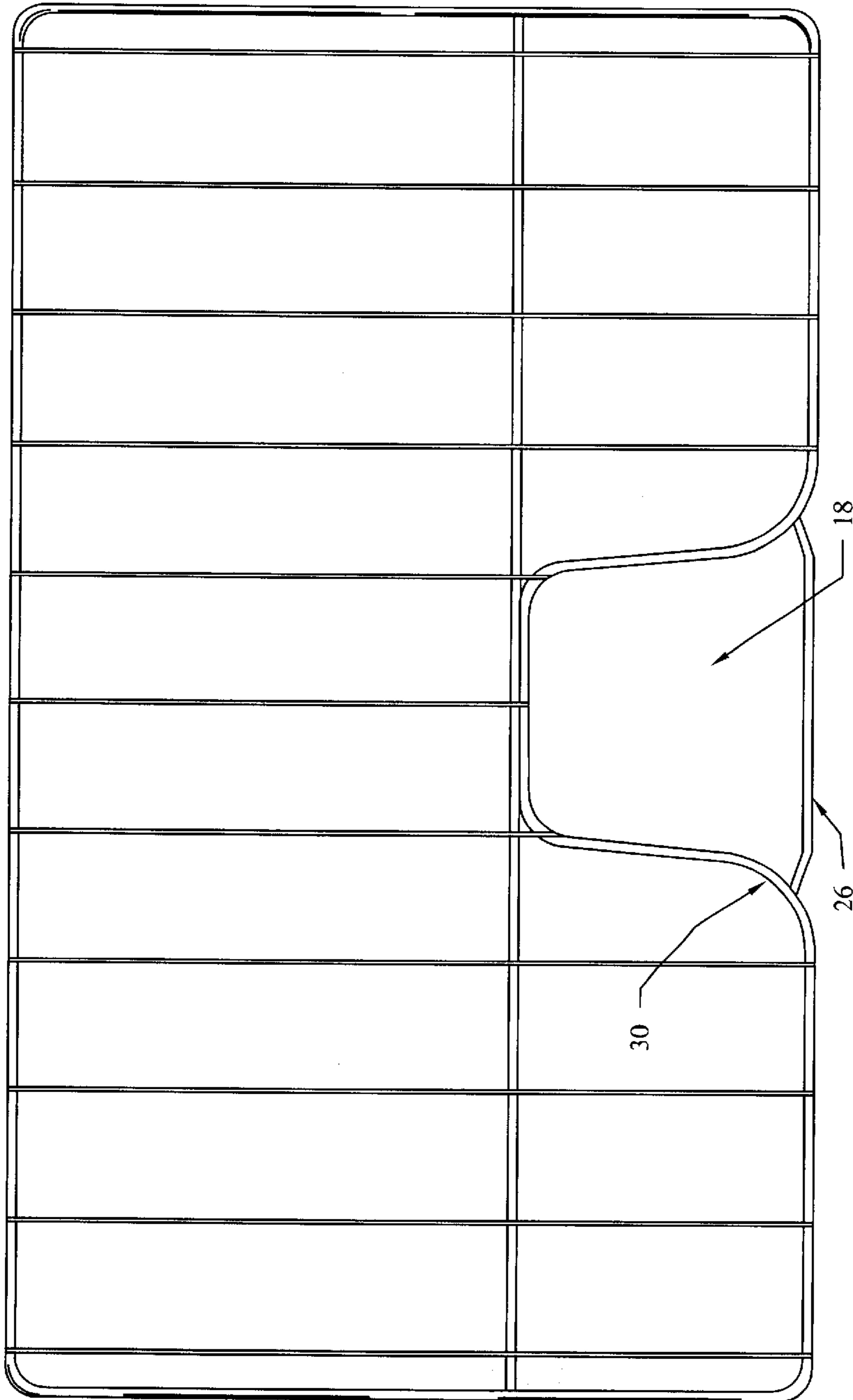

FIG. 6A

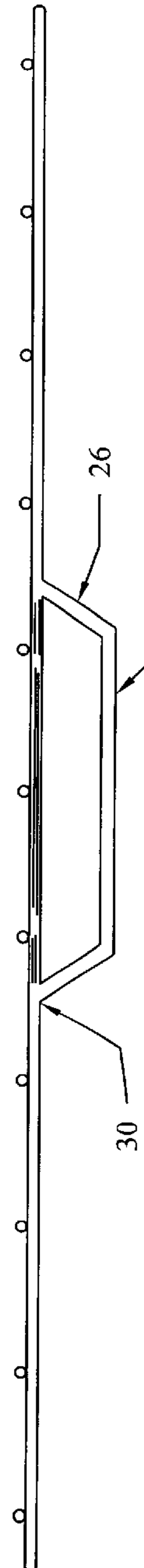

FIG. 6B

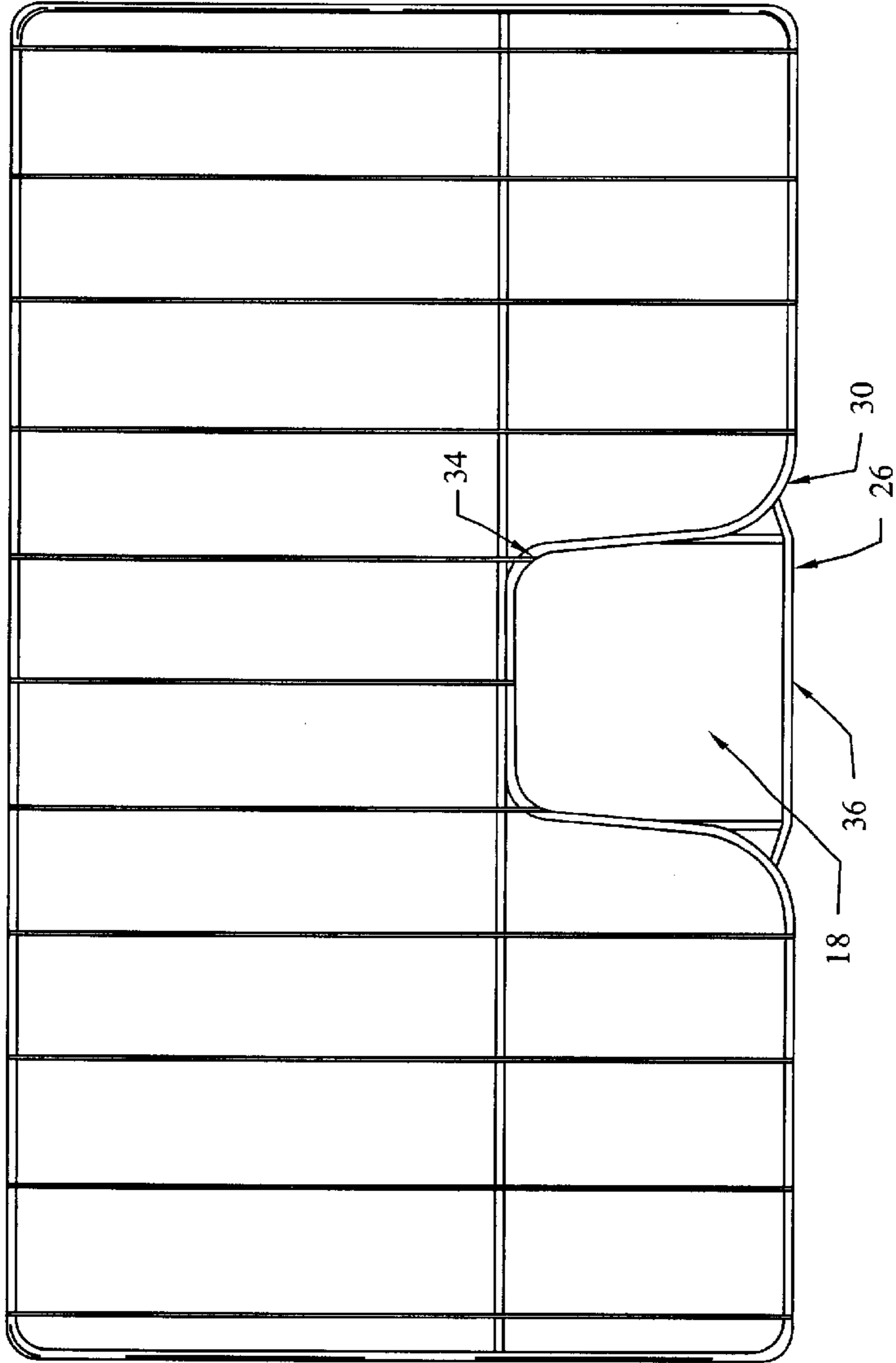

FIG. 7A

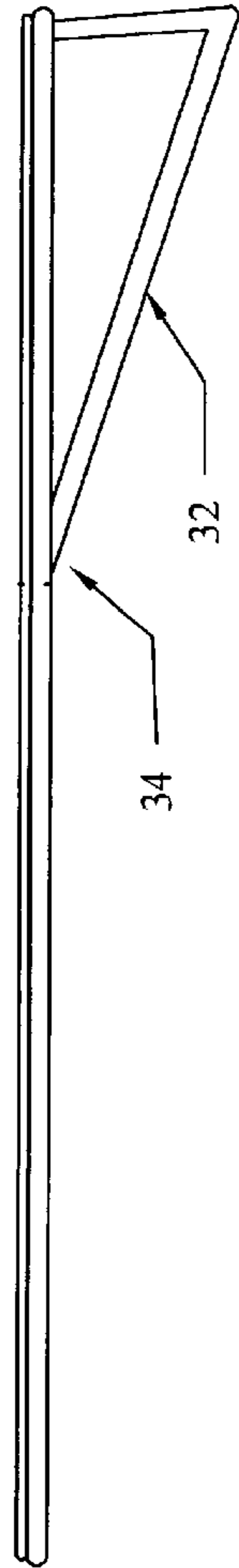

FIG. 7B

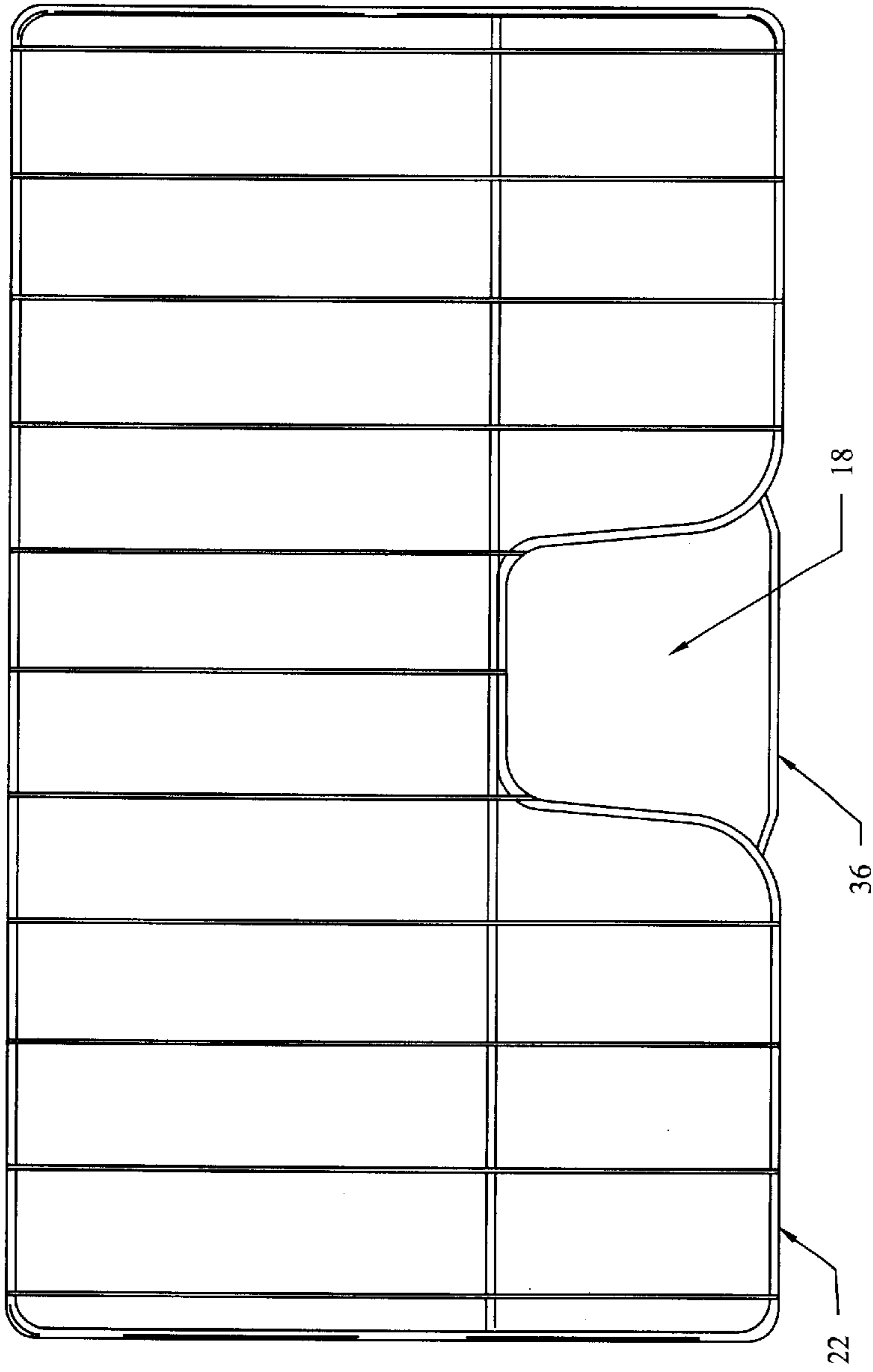

FIG. 8A

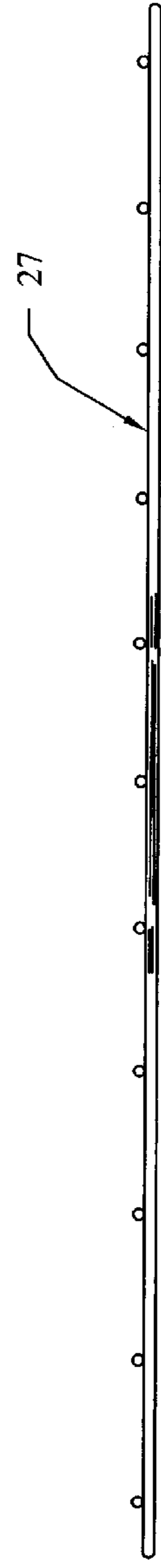

FIG. 8B

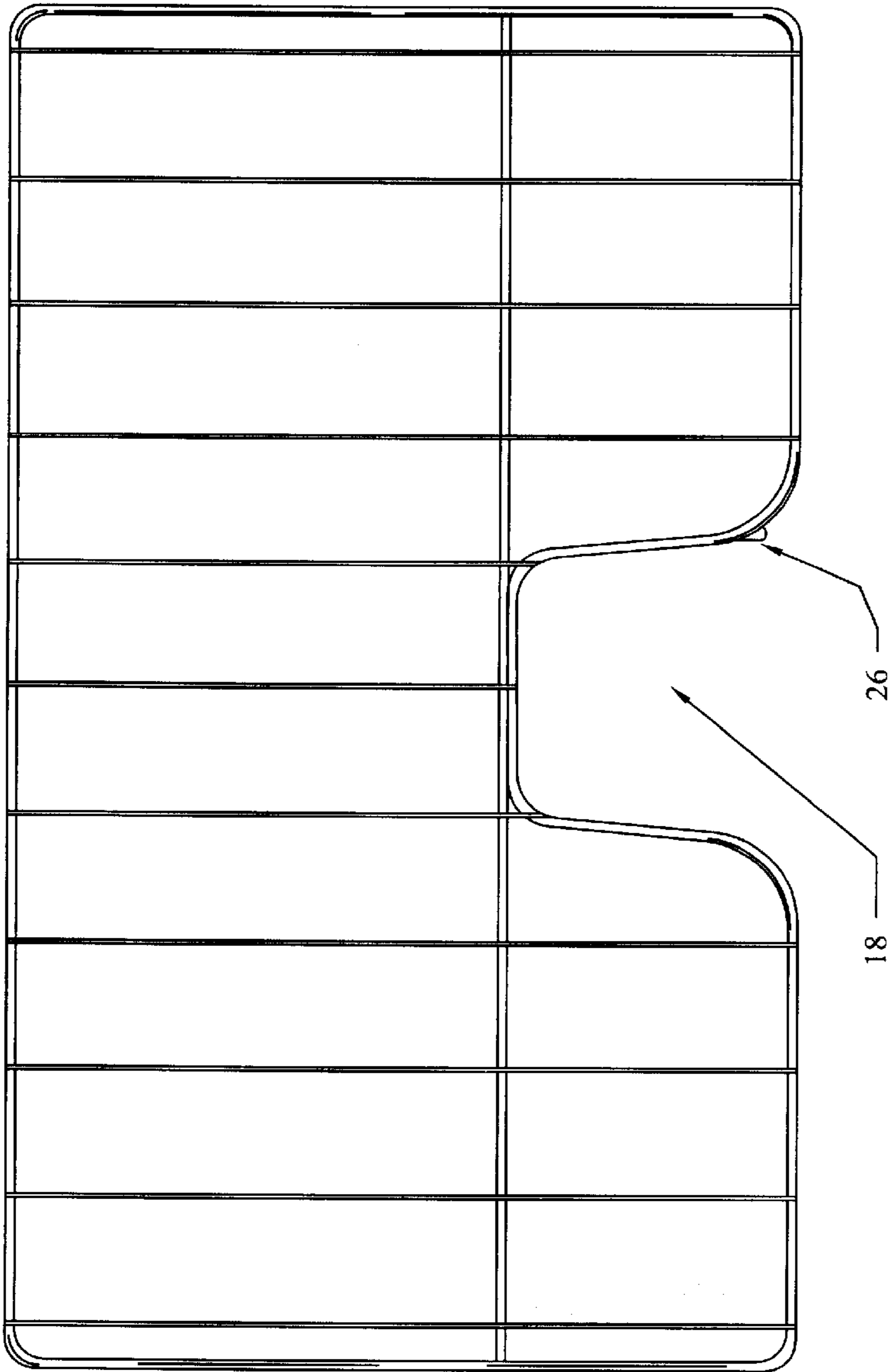

FIG. 9A

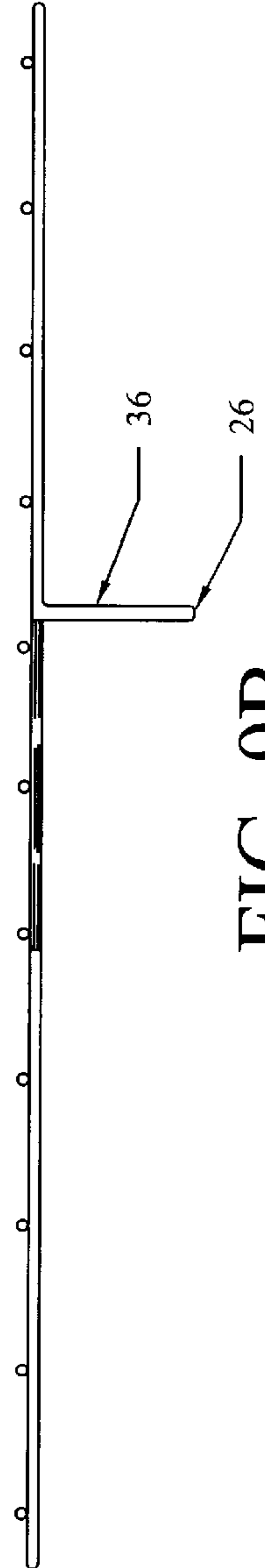

FIG. 9B

OVEN RACK

CROSS REFERENCE TO A RELATED APPLICATION

The subject application is a continuation-in-part of application Ser. No. 09/567,662, filed May 9, 2000, now U.S. Pat. No. 6,205,997.

BACKGROUND OF THE INVENTION

The convenience of free delivery often makes ordering a pizza a more attractive alternative than making one at home. The availability of gourmet and professional equipment, such as pizza stones, however have made preparing an authentic pizzeria-style pizza at home a possibility. A pizza stone cooks the pizza evenly providing a continuous source of heat and the stone absorbs moisture to provide a crispy crust.

Pizza stones are flat having no lip or edge to grab when removing the stone from the oven. Thus, in order to remove a stone, or any other flat item, from an oven, it is necessary to pull the rack out of the oven, reach behind the stone and push the edge of the stone over the lip of the oven rack, and then push the rack back into the oven before grabbing the stone. When the rack is pulled out of the oven, it is only partially supported and can tilt either falling from the oven or dumping its hot contents onto the floor. Additional safety concerns arise when, at home, children and animals are underfoot.

Oven shelves have been designed to address a number of problems encountered in cooking and baking in an oven. For example, Ogg et al. (U.S. Pat. No. 5,938,968) describe a retractable shelf for a microwave oven to assist the cook in accessing foods which have to be turned or stirred while cooking. Slaughter (U.S. Pat. No. 2,806,467) describes an oven shelf with an insulated handle so the rack can be removed without donning an oven mitt. Hanson et al. (U.S. Pat. No. 1,941,301) describe a tray holder which facilitates withdrawal of a tray from the oven and allows the raising and lowering of that tray within the oven. Each of these racks, although useful for its intended purpose, do not address the problem of removing flat items safely from an oven rack.

All patents, patent applications, provisional patent applications and publications referred to or cited herein, or from which a claim for benefit of priority has been made, are incorporated by reference in their entirety to the extent they are not inconsistent with the explicit teachings of the specification.

SUMMARY OF THE INVENTION

The invention is an oven rack which has a notch along its peripheral surface. Items placed into the oven, on the rack, with an edge extending over that notch can be easily removed from the oven without having to slide the rack out of the oven. In a preferred embodiment, this notch is placed on the front of the rack toward the door, near the center and is about 3 inches to about 9 inches wide by about 3 inches to about 9 inches deep allowing adequate room for a hand covered by an oven mitt to reach into the notch and access items on the rack. The oven rack can further include a handle to assist in pulling the rack from the oven.

BRIEF DESCRIPTION OF THE DRAWINGS

FIG. 1A is a top plan view of a preferred embodiment of the oven rack of the subject invention.

FIG. 1B is an elevational view of the tail edge of a preferred embodiment of the oven rack of the subject invention.

FIG. 2A is a top plan view of another preferred embodiment of the oven rack of the subject invention.

FIG. 2B is an elevational view of the tail edge of another preferred embodiment of the oven rack of the subject invention.

FIG. 3A is a top plan view of another preferred embodiment of the oven rack of the subject invention.

FIG. 3B is an elevational view of the tail edge of another preferred embodiment of the oven rack of the subject invention.

FIG. 4A is a top plan view of another preferred embodiment of the oven rack of the subject invention.

FIG. 4B is an elevational view of the tail edge of another preferred embodiment of the oven rack of the subject invention.

FIG. 5 is a front elevational view of an oven with a preferred embodiment of the oven rack of the subject invention.

FIG. 6A is a top plan view of another preferred embodiment of the oven rack of the subject invention.

FIG. 6B is an elevational view of the tail edge of another preferred embodiment of the oven rack of the subject invention.

FIG. 7A is a top plan view of another preferred embodiment of the oven rack of the subject invention.

FIG. 7B is an elevational view of the side edge of another preferred embodiment of the oven rack of the subject invention.

FIG. 8A is a top plan view of another preferred embodiment of the oven rack of the subject invention.

FIG. 8B is an elevational view of the side edge of another preferred embodiment of the oven rack of the subject invention.

FIG. 9A is a top plan view of another preferred embodiment of the oven rack of the subject invention.

FIG. 9B is an elevational view of the tail edge of another preferred embodiment of the oven rack of the subject invention.

DETAILED DISCLOSURE OF THE INVENTION

The oven rack of the subject invention has a notch along its periphery. The notch allows flat items to be removed from the oven without having to pull the rack from the oven.

A preferred embodiment of the oven rack **10** of the subject invention is shown generally at **10** in FIG. 1A. The rack is defined by a frame **12** supporting a plurality of bars **14** and an optional cross-member **16**. The frame **12** has a notch **18** in its periphery.

In the exemplified embodiment, the rack of the subject invention is used in an oven **19** (FIG. 5). A conventional oven is a closed box having a top, bottom and four sides. A door **21** on one side of the box accesses the oven. In place in the oven, the rack of the subject invention has a leading edge **20**, tail edge **22**, and two side edges **24**. The rack is supported in the oven by the sides **24** which engage tracks **25** usually integrally formed from the oven wall. The leading edge **20** slides into the oven and rests against the side opposite the door. The tail edge **22** of the rack faces the oven door.

The frame and bars of the rack of the exemplified embodiment are made from steel which provides adequate strength

to support items such as cake pans, pizza stones and casseroles and withstands the heat of an oven. The frame **12** was created by bending a $\frac{1}{4}$ inch steel bar. Steel bars ($\frac{1}{8}$ inch) were cut to size and spot welded on the frame as bars **14**.

The rack of the subject invention can be used in settings other than in an oven. For example, the rack of the subject invention could be used in a freezer unit. Materials suitable for constructing a rack to be used in a freezer unit could include plastic coated wire. The materials from which the racks are constructed must be appropriate for the intended use of the rack and possess the desired supporting strength. These suitable materials can include, but are not limited to, plastics, other metals, such as aluminum, or organic materials. It is important to note, the frame **12**, the bars **14** and the cross-member **16** need not be constructed from the same materials.

The size of the frame **12** of the rack of the subject invention also depends upon the intended use of the rack. In the exemplified embodiment, the rack is sized to slide into or replace a rack of a conventional oven. Likewise, the bars **14** are spaced to accommodate cookware. The frame can be made larger to fit commercial ovens or sized to fit any apparatus in which the racks are to be used. The bars of the rack can be spaced appropriately within the frame to hold any designated item.

In the exemplified embodiment, the notch **18** is on the tail edge **22** near the center of the rack. The notch can be any size. The racks shown in the Figures are intended for use in a conventional home oven. Thus, the notch **18** measures from about 3 inches wide to about 9 inches wide and from about 3 inches deep to about 9 inches deep and, preferably from about 4 inches wide to about 6 inches wide and from about 4 inches deep to about 6 inches deep and, most preferably, the notch is about $5\frac{1}{2}$ inches wide and about $5\frac{1}{2}$ inches deep. This allows adequate space for a protected hand to grab an item from the rack. A larger notch could allow more than one item to be accessed through the notch or may be more suitable for larger industrial ovens or institutional uses. The notches can also be any shape. The notch in the rack of the exemplified embodiment is square, equal in length and width. The notch in the rack could be, for example, a half-circle (FIG. 2A) or elliptical (FIG. 3A). Further, the notch could be rectangular, unequal in length and width. Notches designed for the removal of industrial or institutional sized baking trays are also contemplated. Additionally, the notch **18** need not be placed near the center of the rack, nor does there need to be a single notch per rack. A notch placed nearer the side of the rack, and the side of the oven, still allows the items which span the notch to be removed without sliding the rack from the oven. Further, a rack for a specialized oven, for example a pizza oven, could have two or more notches along its periphery so a number of pizza stones could be placed in the oven. The size and placement of the notch does not effect the use of the rack for standard baking or cooking. Heavy roasters or cake pans are fully supported by the rack of the subject invention. In fact, the notch in the rack of the subject invention allows a cook to place a hand firmly under a heavy item while lifting it from the oven. The heavy item is better supported upon removal from the oven which is safer for the cook and others in the kitchen.

The rack can be pulled from the oven should the cook wish to check the cooking progress just as on a regular oven rack. The subject rack can further include a handle to assist in removing the rack from the oven. A preferred embodiment of the handle is shown in FIG. 6. The handle **26** is suspended from about $\frac{1}{4}$ inch to about four inches below the surface of

the rack **27** (FIG. 6B). Positioning the handle below the rack's surface allows unobstructed access to the notch **18**. Thus, a flat item placed on the rack of the subject invention having a dropped handle can be removed from the surface of the rack by accessing the item through the notch. In a particularly preferred embodiment, the handle is suspended from about $\frac{1}{2}$ to about $\frac{3}{4}$ inches below the surface of the rack. When the grasp **36** of the handle is about $\frac{1}{2}$ – $\frac{3}{4}$ inches below the surface of the rack it does not interfere with access or removal of items placed on the rack below.

The handle **26** can be a simple U-shaped bar suspended below the surface of the oven rack. In a specific embodiment, the handle, is a flattened U-shaped with each arm of the U being attached to an outer corner **30** of the notch **18** (FIG. 6A). The arms of the U are sufficient length to allow passage of a protected hand into the notch.

An alternative embodiment of the handle of the rack of the subject invention includes a simple flattened U-shaped bar supported by braces **32** running from the inside corners of the notch **34** toward the periphery or tail edge of the rack (FIG. 7A). The arms of the U are attached to the rack at the outer edges of the notch **18**. The arms of the U are from about $\frac{1}{4}$ inch to about four inches long and preferably about $\frac{3}{4}$ inches long. The braces **32** attach to the inner corners **34** of the notch on the oven rack and to the handle at the points of attachment of the arms of the U **28** and the grasp **36**. Thus, the distance between the rack and the brace increases as one moves toward the tail edge **22** of the rack. The position of the braces **32** are seen most clearly in FIG. 7B.

Another embodiment of the handle of the rack of the subject invention includes a flattened U-shape handle on the same plane as the surface of the rack **27**. The arms of the U are preferably about $\frac{1}{4}$ inch to $\frac{3}{4}$ inch long extending the grasp **36** of the handle at or past the periphery or tail edge **22** of the rack and toward the door of the oven a sufficient distance to allow a protected hand to slip through the handle and into the notch to access an item on the rack (FIGS. 8A and 8B). The handle should not interfere with closure of the oven door.

The handle **26** of the rack of the subject invention in the illustrated embodiments are flattened U-shapes. The subject handles however can be any shape, including but not limited to, rounded U-shapes, other pulls, knobs or simple bars. For example, a simple bar extending from the surface of the rack about $\frac{1}{2}$ inch to about $\frac{3}{4}$ inch toward the bottom of the oven can act as a handle (FIGS. 9A and 9B).

The handles **26** on the rack of the subject invention can be made from the same material as the rack. For example, the handles can be fashioned from $\frac{1}{4}$ inch steel bars which are spot welded to the frame. Alternatively, the handles can be made of an insulated material to protect someone grasping the handle from burns. Suitable insulating materials include ceramics which can likewise be applied to the handle to provide insulation qualities.

The handles described are placed at the notch of the subject rack. Handles can be placed on the rack however anywhere on the edge of the rack. For example, handles placed on either side of the notch can extend either above or below the surface of the rack. Further, handles extending from the tail edge of the rack are suitable for use with the subject rack provided they do not interfere with the notch or interfere with closing the oven door.

The rack of the subject invention is safer than a regular oven rack when removing flat items from the oven. To remove a flat item from a regular oven rack, it is necessary to pull the rack partially out of the oven and reach behind the

5

item to push the edge of the item over the lip of the rack. The rack is usually then slid back into the oven and the flat item is removed from the rack. This practice is unsafe because the partially removed rack is not fully supported and can tip falling from the oven or dumping hot food items. Further, the oven is left open for a period of time during this process leaving its hot surfaces accessible to small children. When a flat item is placed on the rack of the subject invention, traversing the notch, the item can be easily and safely removed by grabbing its edge in the notch.

Additionally, the rack of the subject invention provides access to items on the bottom rack without the fear of being burned. Little room is left between the top and bottom racks to grab the lip of a pan on the bottom rack. A cook can burn a hand or wrist on the upper rack while reaching past the rack to access items on the lower rack. The rack of the subject invention provides access to items on the lower rack through the notch preventing possible burns. Likewise, the rack of the subject invention can prevent "burning" when reaching into an ultra-cold (-20° C.) freezer.

Further, the rack of the subject invention requires that the oven be open only a short period of time. It is not necessary to partially remove the subject rack to adjust the cookware sitting on it when attempting to remove items from the oven. A flat item is easily removed by grabbing the edge of the item which transverses the notch. Thus, the oven door is open only briefly saving energy and assuring a more constant cooking temperature.

It should be understood that the examples and embodiments described herein are for illustrative purposes only and that various modifications or changes in light thereof will be suggested to persons skilled in the art and are to be included within the spirit and purview of this application.

What is claimed is:

1. A rack for an oven, said rack, comprising; a frame supporting a plurality of bars, said frame having a periphery with at least one notch, said notch measuring from about 3 inches to about 9 inches wide and from about 3 inches to about 9 inches deep allowing adequate room to receive a protected hand of a user, said notch facing a door of said oven, and said notch near the center of said rack, and a handle facing said door of said oven, wherein a flat item having an edge spanning said notch can be removed from said rack without having to pull said rack from said oven.

2. The rack of claim 1, wherein said notch is from about 4 inches to about 6 inches wide and from about 4 inches to about 6 inches deep.

6

3. The rack of claim 1, wherein said notch is about $5\frac{1}{2}$ inches wide by about $5\frac{1}{2}$ inches deep.

4. The rack of claim 1, wherein said notch is semi-circular.

5. The rack of claim 1, wherein said notch is elliptical.

6. The rack of claim 1, wherein said notch is rectangular.

7. The rack of claim 1, comprising at least two notches.

8. The rack of claim 1, wherein said handle is a bar.

9. The rack of claim 1, wherein said handle is flattened U-shaped.

10. The rack of claim 1, wherein said handle further comprises braces.

11. The rack of claim 1, wherein said handle is from about $\frac{1}{4}$ inch to about four inches below the surface of said rack.

12. The rack of claim 1, wherein said handle is about $\frac{1}{2}$ inch below the surface of said rack.

13. The rack of claim 1, wherein said handle is on the same plane as said notch.

14. A method of removing an item from an oven rack, said rack comprising a frame supporting a plurality of bars, said frame having a periphery with at least one notch, said notch measuring from about 3 inches to about 9 inches wide and from about 3 inches to about 9 inches deep allowing adequate room to receive a protected hand of a user, said notch facing a door of said oven, and said notch near the center of said rack, said method comprising the steps of:

- (a) accessing said item through said notch; and
- (b) removing said item from the rack,

wherein said item having an edge spanning said notch can be removed from said rack without having to pull said rack from said oven.

15. A method of removing an item from an oven rack, said rack comprising a frame supporting a plurality of bars, said frame having a periphery with at least one notch, said notch measuring about $5\frac{1}{2}$ inches wide by about $5\frac{1}{2}$ inches deep allowing adequate room to receive a protected hand of a user, said notch facing a door of said oven, and said notch near the center of said rack, said method comprising the steps of:

- (a) accessing said item through said notch; and
- (b) removing said item from the rack,

wherein said item having an edge spanning said notch can be removed from said rack without having to pull said rack from said oven.

* * * * *