



US006644221B2

(12) **United States Patent**
Griepentrog

(10) **Patent No.:** **US 6,644,221 B2**
(45) **Date of Patent:** **Nov. 11, 2003**

(54) **LATCH MECHANISM FOR FOLDING TABLE**

(75) Inventor: **Dennis G. Griepentrog**, DePere, WI (US)

(73) Assignee: **Krueger International, Inc.**, Green Bay, WI (US)

(*) Notice: Subject to any disclaimer, the term of this patent is extended or adjusted under 35 U.S.C. 154(b) by 184 days.

(21) Appl. No.: **09/769,685**

(22) Filed: **Jan. 25, 2001**

(65) **Prior Publication Data**

US 2002/0152936 A1 Oct. 24, 2002

Related U.S. Application Data

(62) Division of application No. 09/441,237, filed on Nov. 16, 1999, now Pat. No. 6,223,661.

(51) **Int. Cl.**⁷ **A47B 3/007**

(52) **U.S. Cl.** **108/169; 108/173**

(58) **Field of Search** 108/168, 167, 108/166, 169, 172, 171, 173, 174, 115

(56) **References Cited**

U.S. PATENT DOCUMENTS

- 2,721,778 A 10/1955 Wilson
- 2,747,958 A 5/1956 Wilson
- 2,764,460 A 9/1956 Nelson
- 2,766,089 A 10/1956 Nielsen
- 2,777,742 A 1/1957 Schieber
- RE24,454 E 4/1958 Wilson
- 2,831,740 A 4/1958 Schieber
- 2,831,741 A 4/1958 Wilson
- 2,873,157 A 2/1959 Wilson
- 2,879,120 A 3/1959 Howe et al.
- 2,901,304 A 8/1959 Fihe
- 3,080,833 A 3/1963 Risdall
- 3,080,834 A 3/1963 Risdall
- 3,101,062 A 8/1963 Kanzelberger

- 3,140,674 A 7/1964 Cisler
- 3,143,982 A 8/1964 Blink et al.
- 3,212,463 A 10/1965 Anderson et al.
- 3,245,363 A 4/1966 Amthor, Jr. et al.
- 3,276,401 A 10/1966 Wilson et al.
- 3,476,061 A 11/1969 Takahashi
- 3,799,073 A 3/1974 Nielsen
- 3,884,160 A 5/1975 Gutierrez
- 4,027,600 A * 6/1977 Mueller
- 4,054,096 A 10/1977 Wilson et al.
- 4,131,311 A 12/1978 Nikitits et al.
- 4,133,271 A * 1/1979 Carlson
- 4,223,945 A 9/1980 Nikitits

(List continued on next page.)

FOREIGN PATENT DOCUMENTS

FR 1280051 11/1961

Primary Examiner—Jose V. Chen

(74) *Attorney, Agent, or Firm*—Boyle, Fredrickson, Newholm, Stein & Gratz, S.C.

(57) **ABSTRACT**

A folding sectional table assembly includes a pair of table sections, each of which includes a frame assembly and a table top. Each frame assembly includes inner and outer leg assemblies, and each leg assembly has an upper tubular member pivotably mounted at its ends relative to a pair of apron members secured to the underside of the table top, for providing pivoting movement of the leg assembly relative to the table top. A latch arrangement selectively maintains the table sections in the folded, storage position, and includes a latch member pivotably mounted to one of the table sections and a catch member stationarily mounted to the other of the table sections. A latch actuator is interconnected between the latch member and the apron members, for disengaging the latch member from the catch member when it is desired to move the table sections away from the folded, storage position. The latch actuator includes an actuator area located adjacent each side of the table assembly, for enabling an operator to easily access the actuator member for disengaging the latch member without having to reach between the table sections when in the folded, storage position.

15 Claims, 13 Drawing Sheets

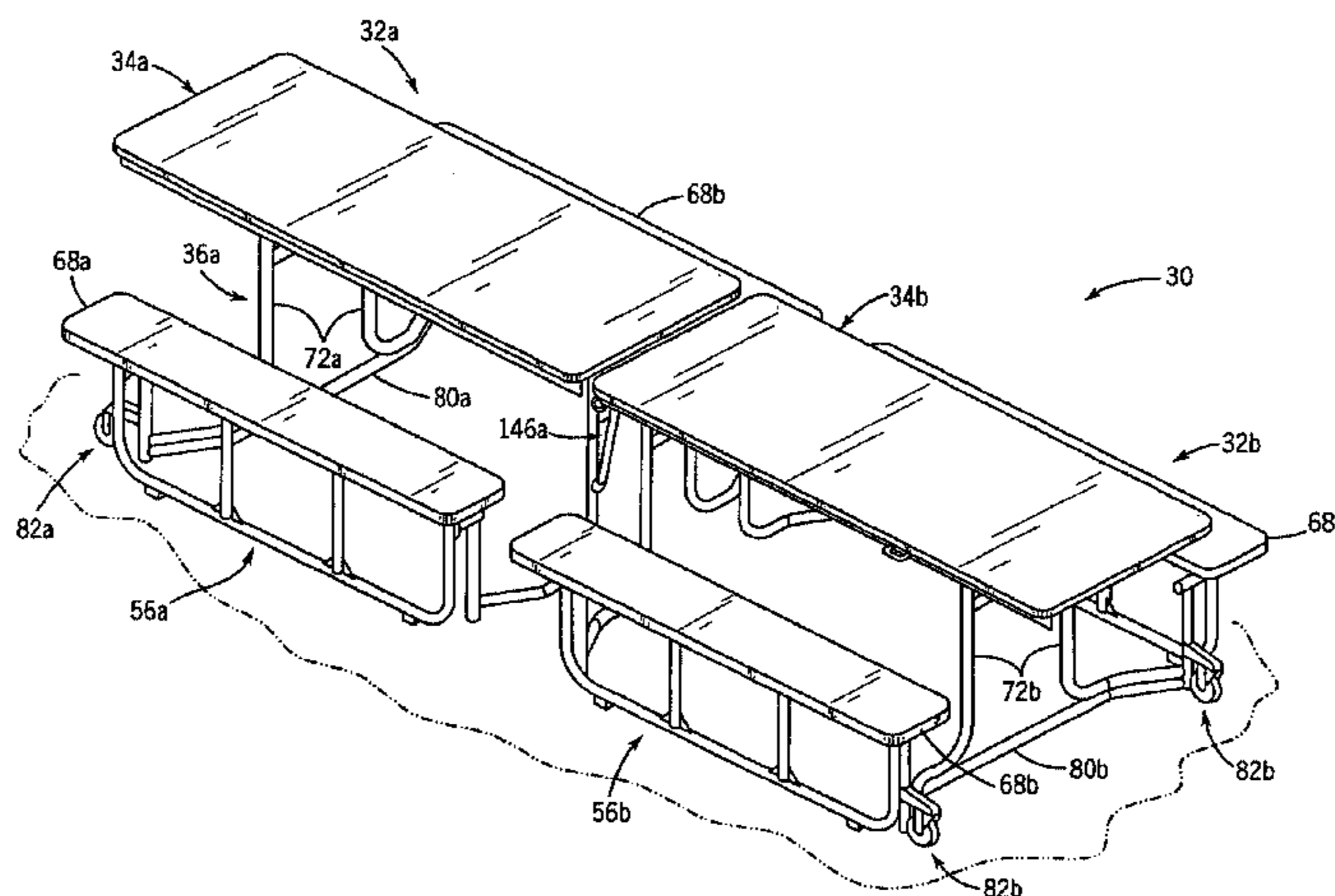

U.S. PATENT DOCUMENTS

4,489,661 A	12/1984	Fitzgerald	5,080,024 A	1/1992	Yamamoto
4,596,196 A	6/1986	Gunter et al.	5,325,640 A *	7/1994	Luedke et al.
4,819,569 A	4/1989	Bastian et al.	6,082,051 A *	7/2000	Burton et al.
4,826,244 A	5/1989	Choi	6,164,016 A *	12/2000	Bue et al.
5,029,938 A	7/1991	Song	6,386,628 B2 *	5/2002	Bue

* cited by examiner

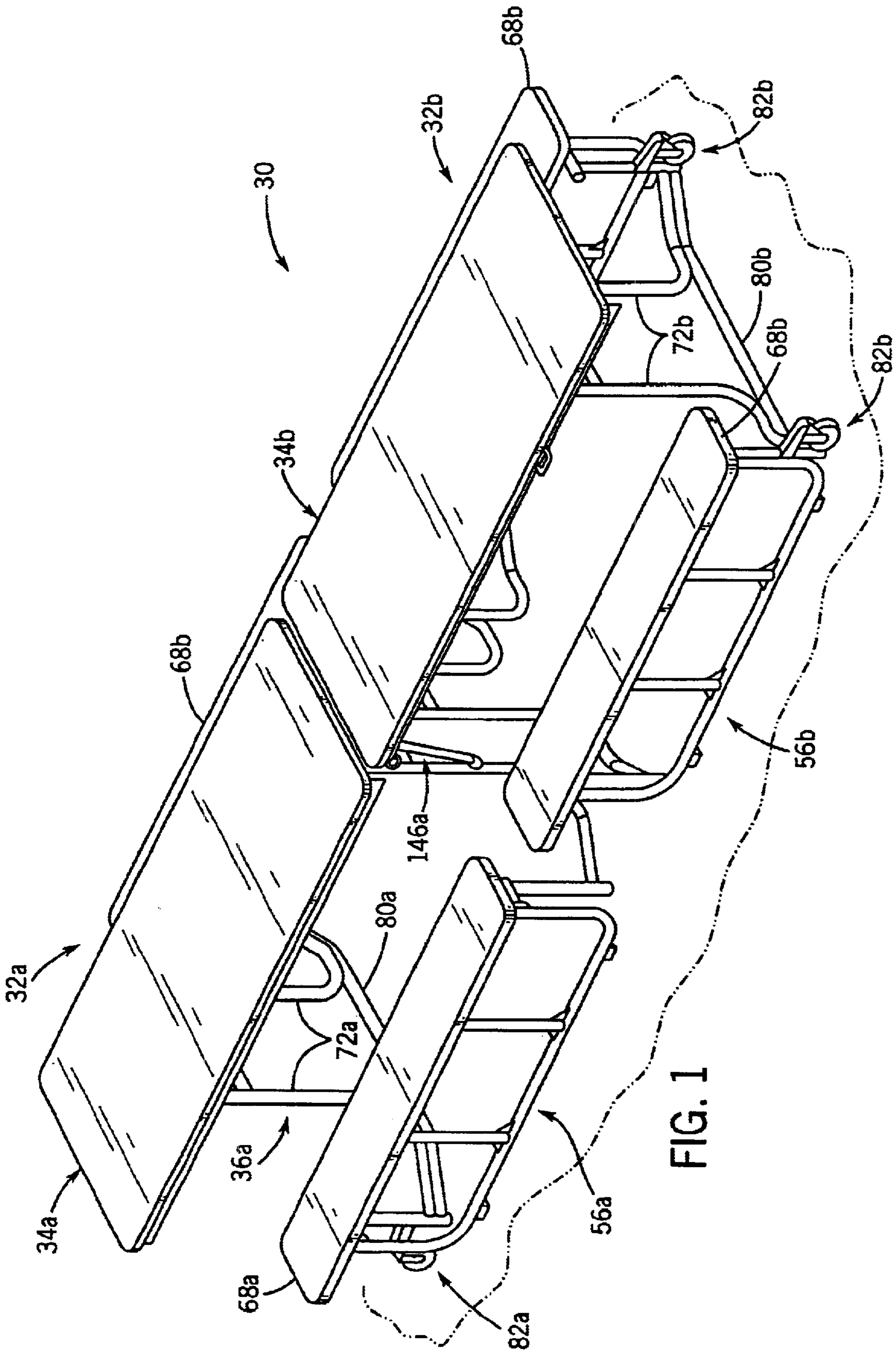

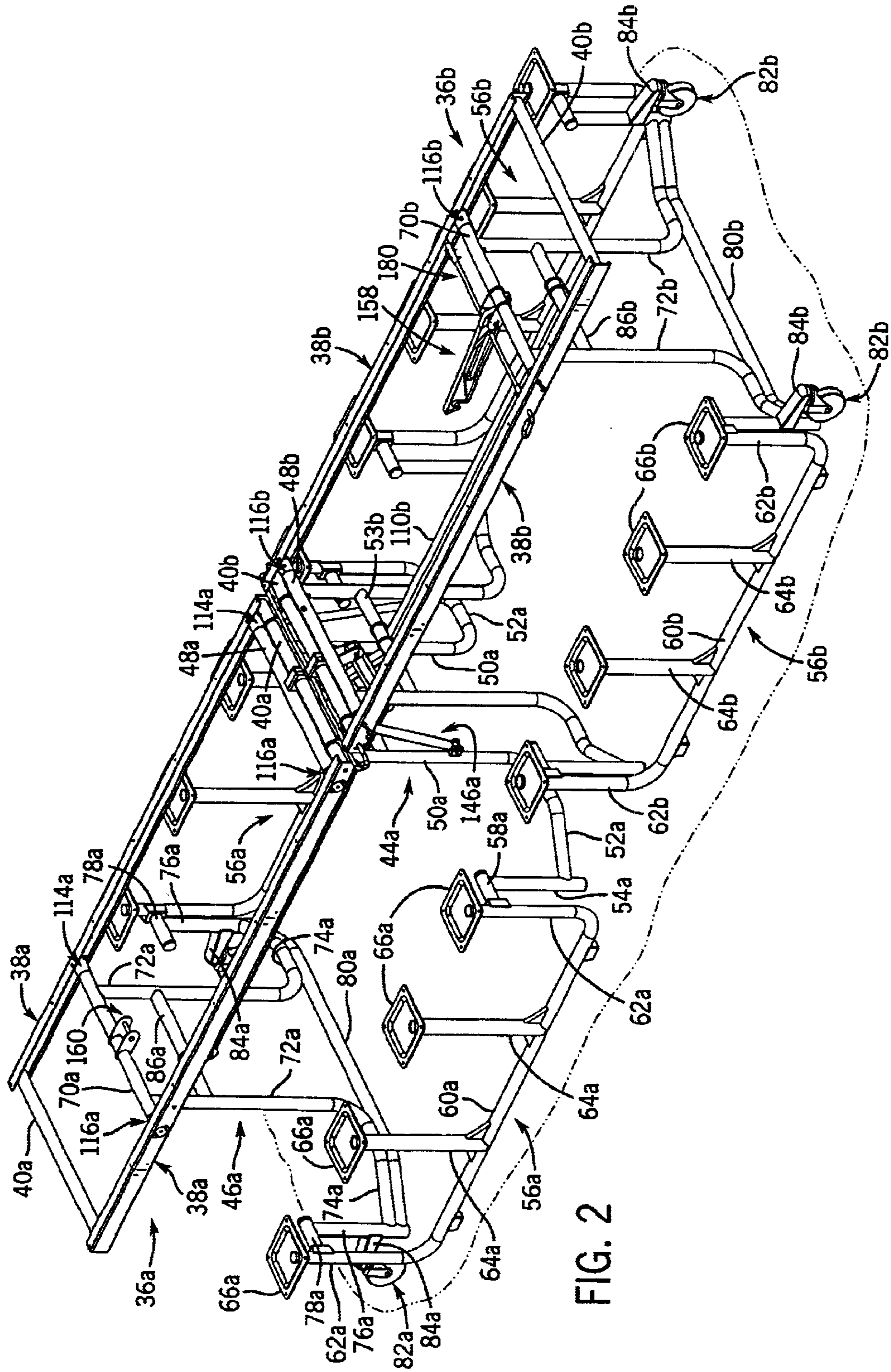

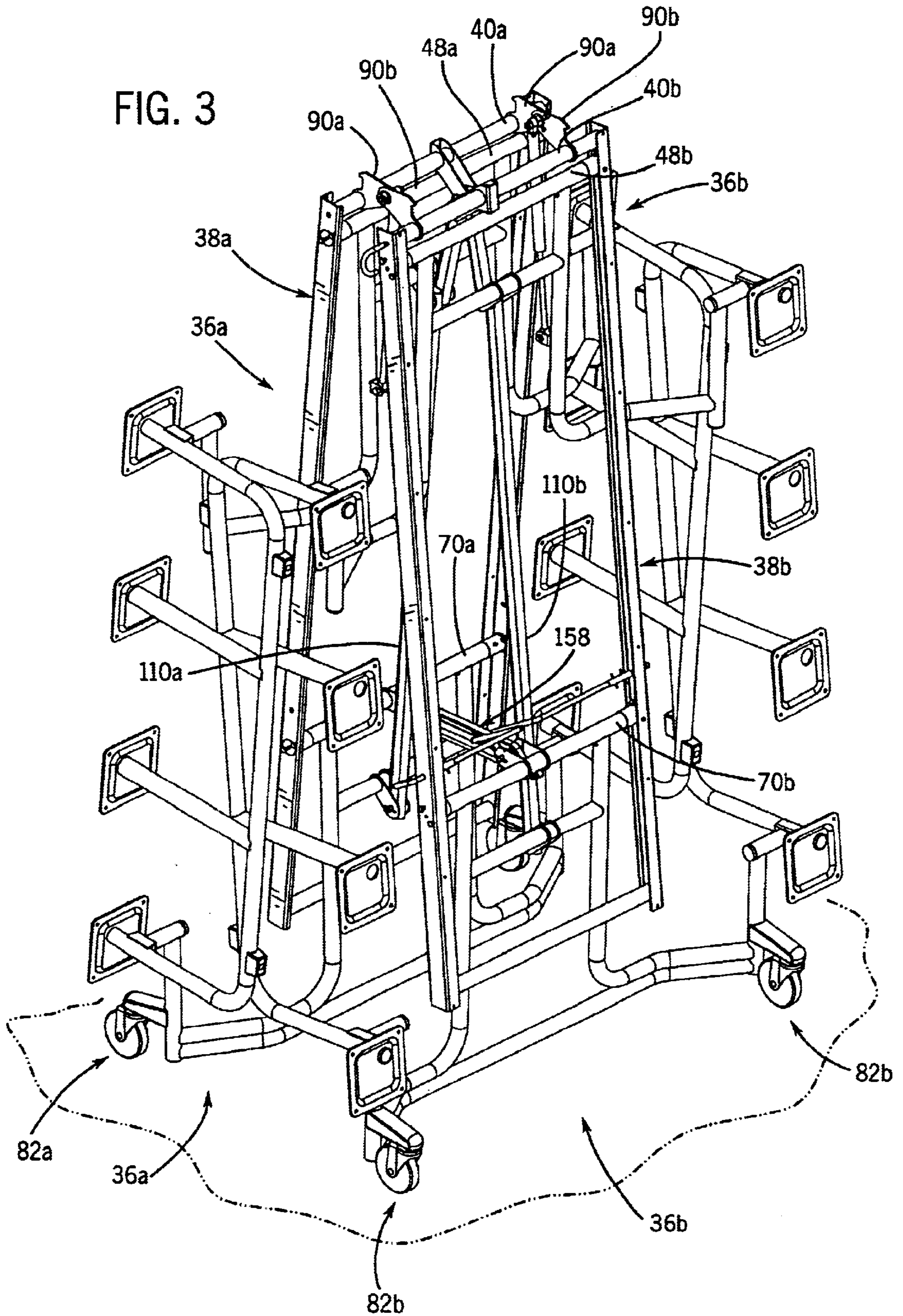

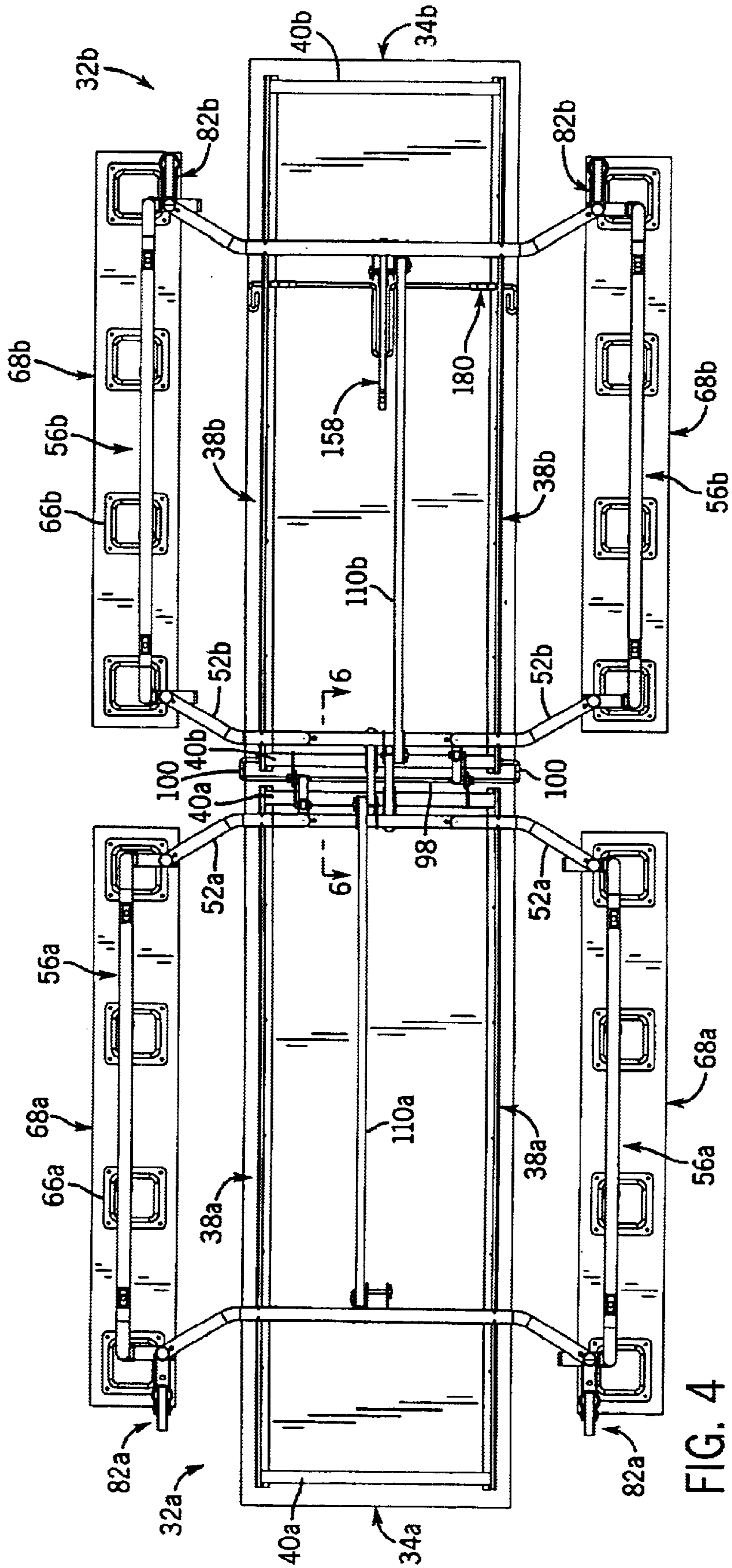

FIG. 4

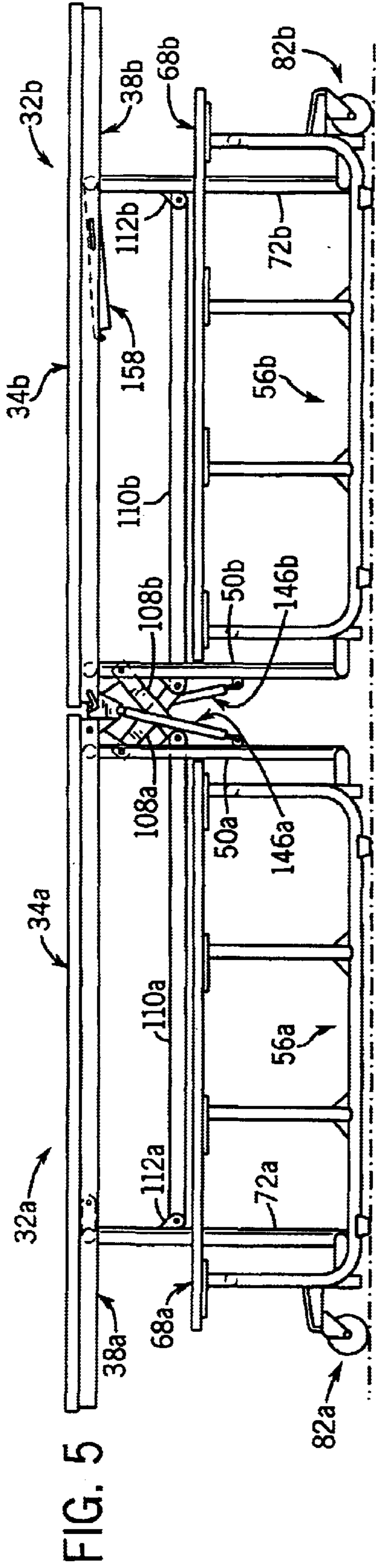

FIG. 5

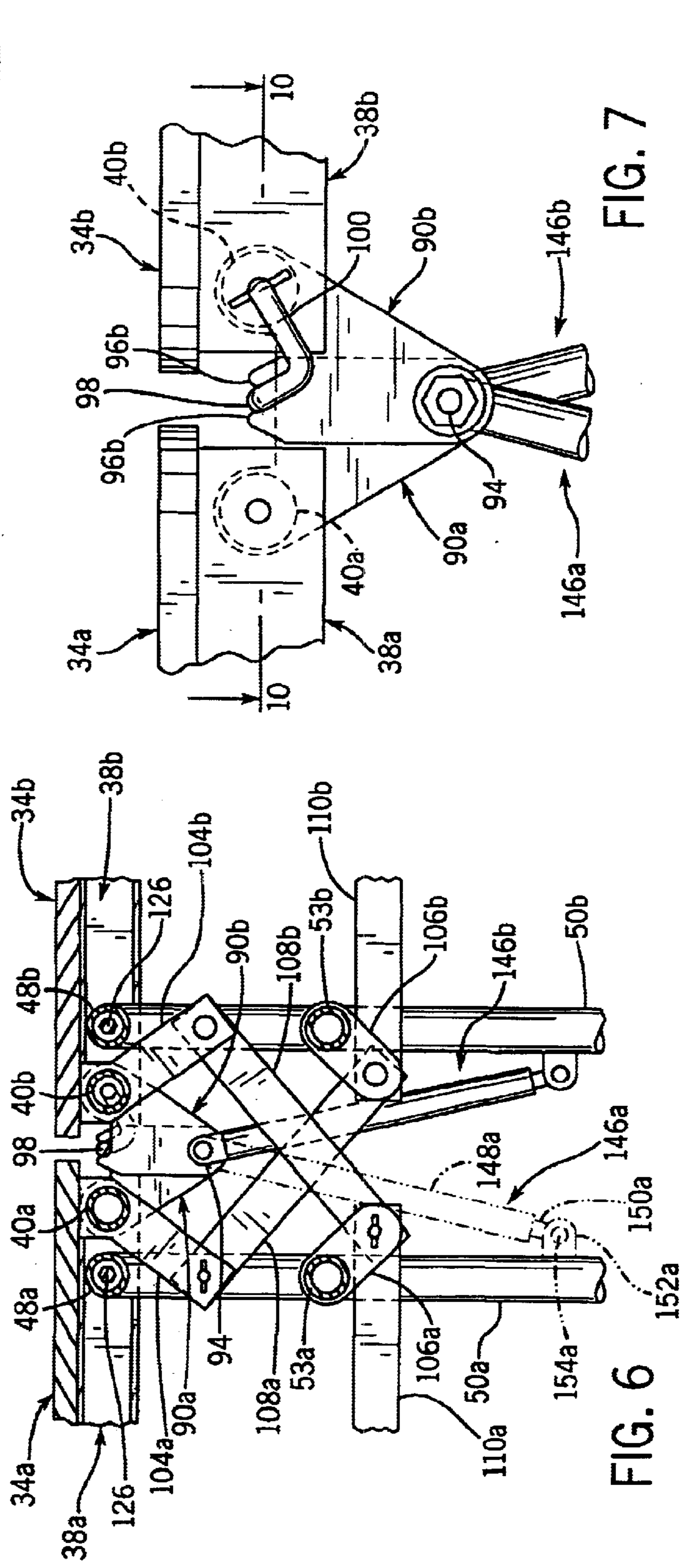
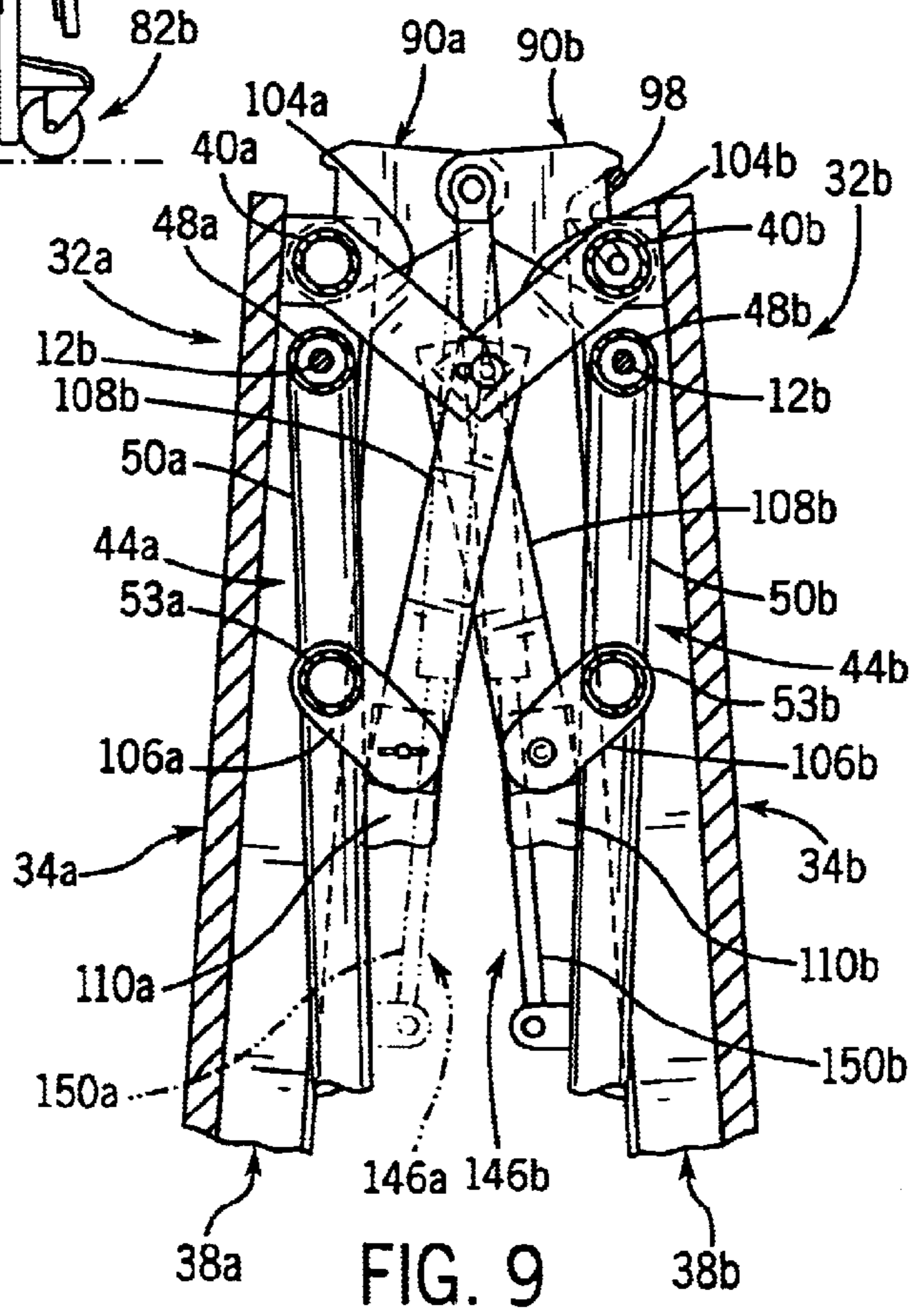
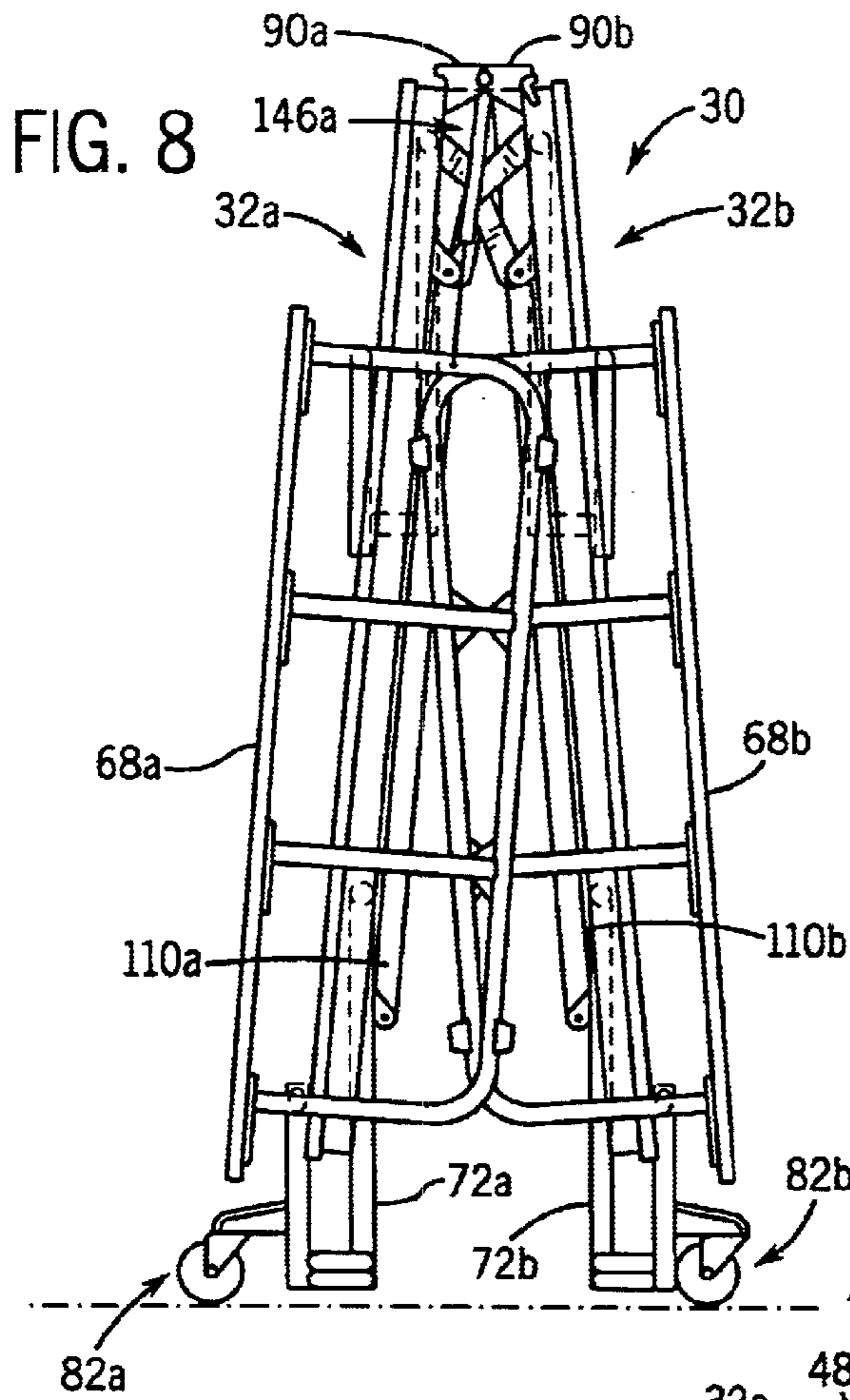

FIG. 6

FIG. 7



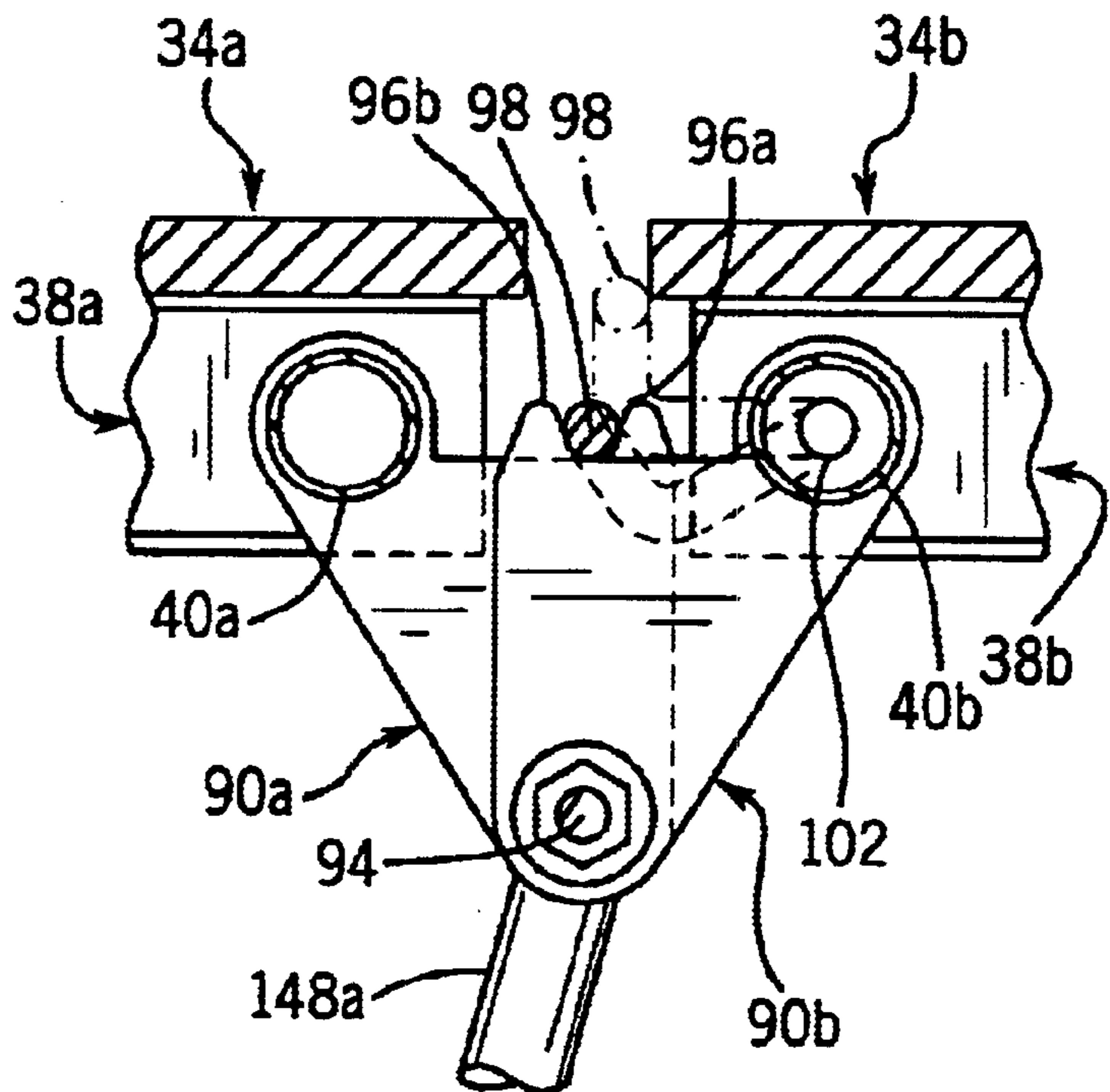
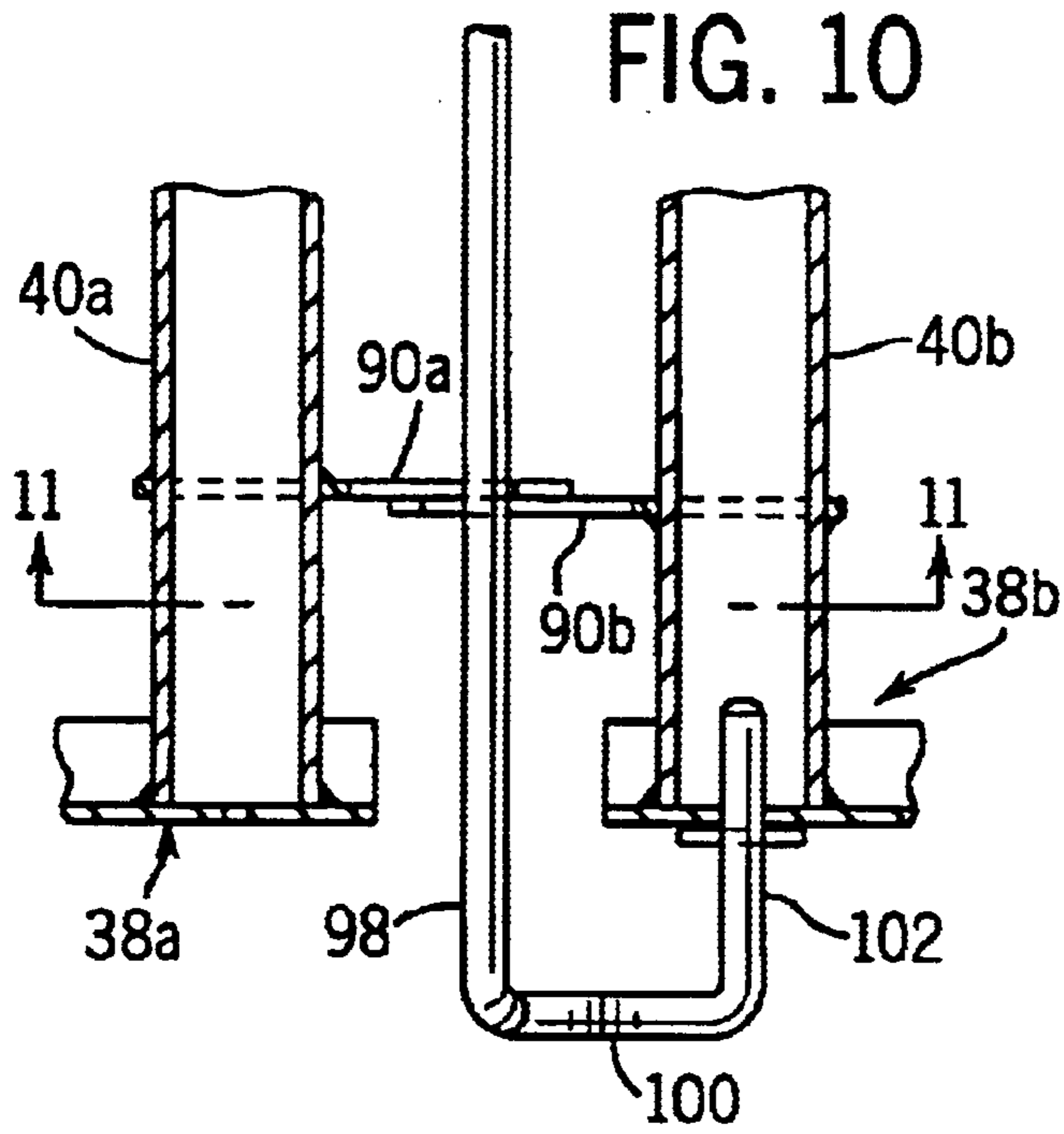

FIG. 11

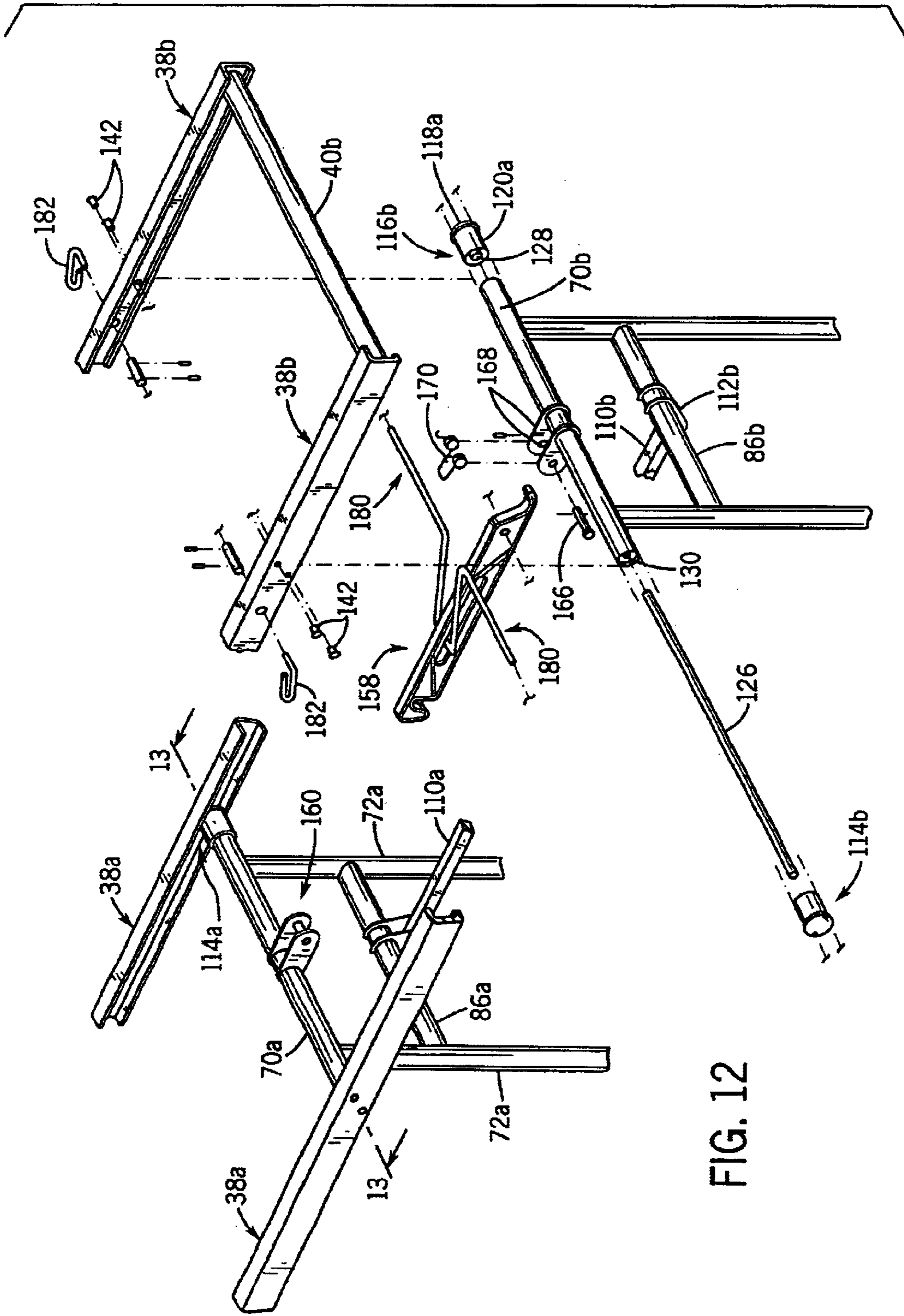

FIG. 12

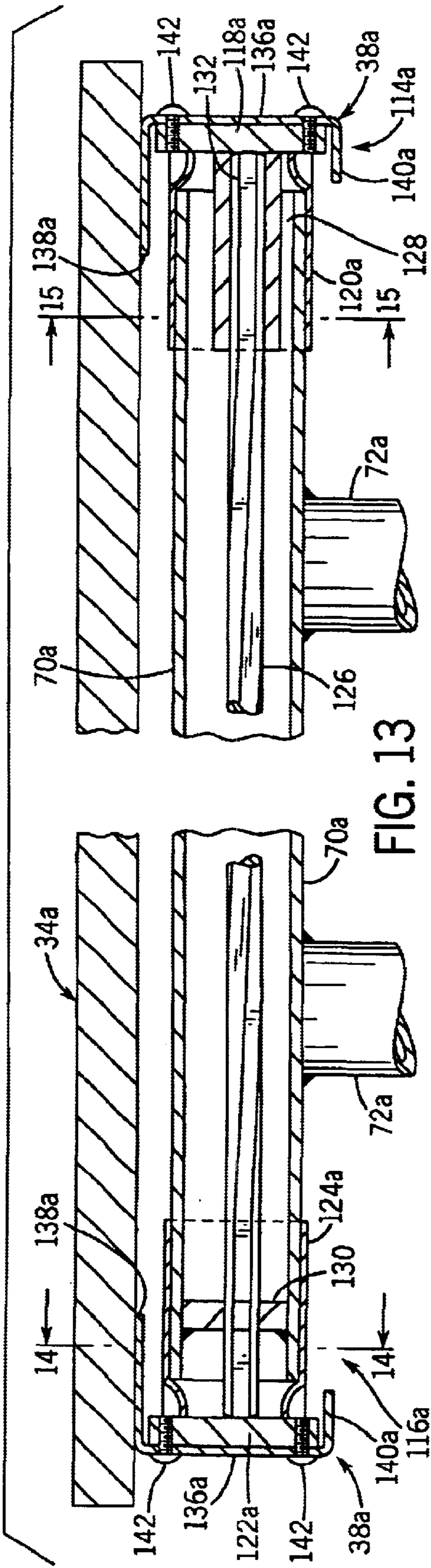

FIG. 13

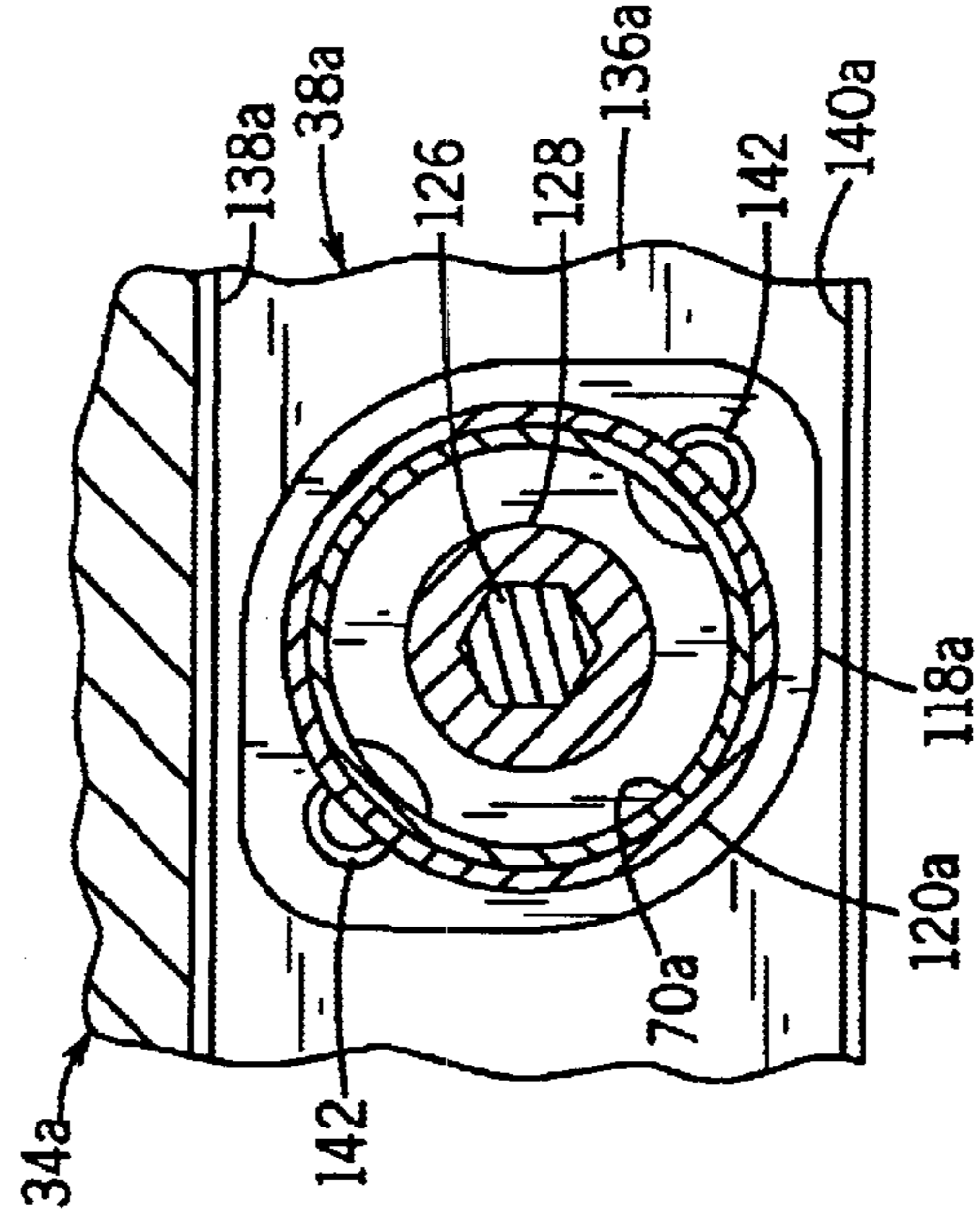

FIG. 15

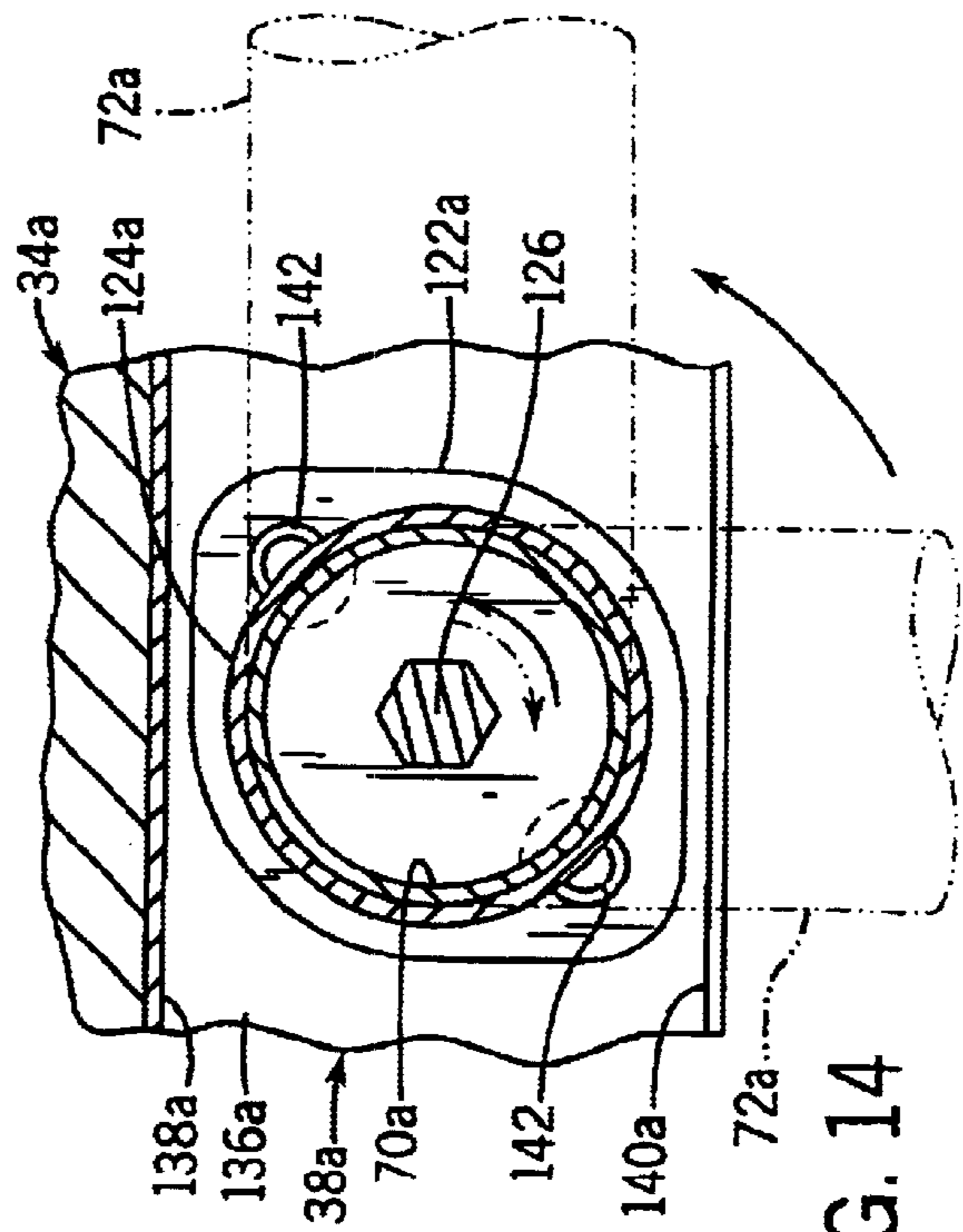
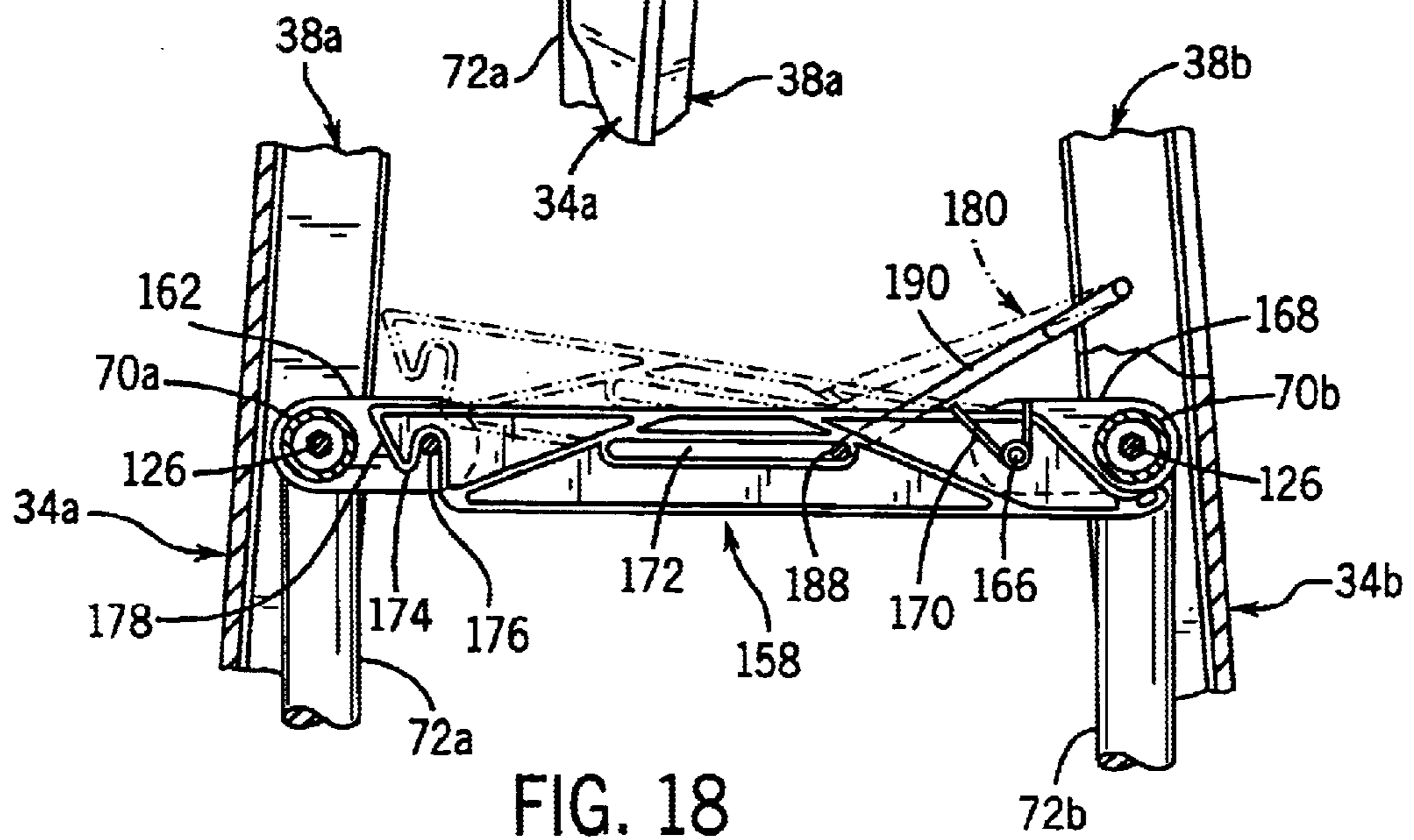
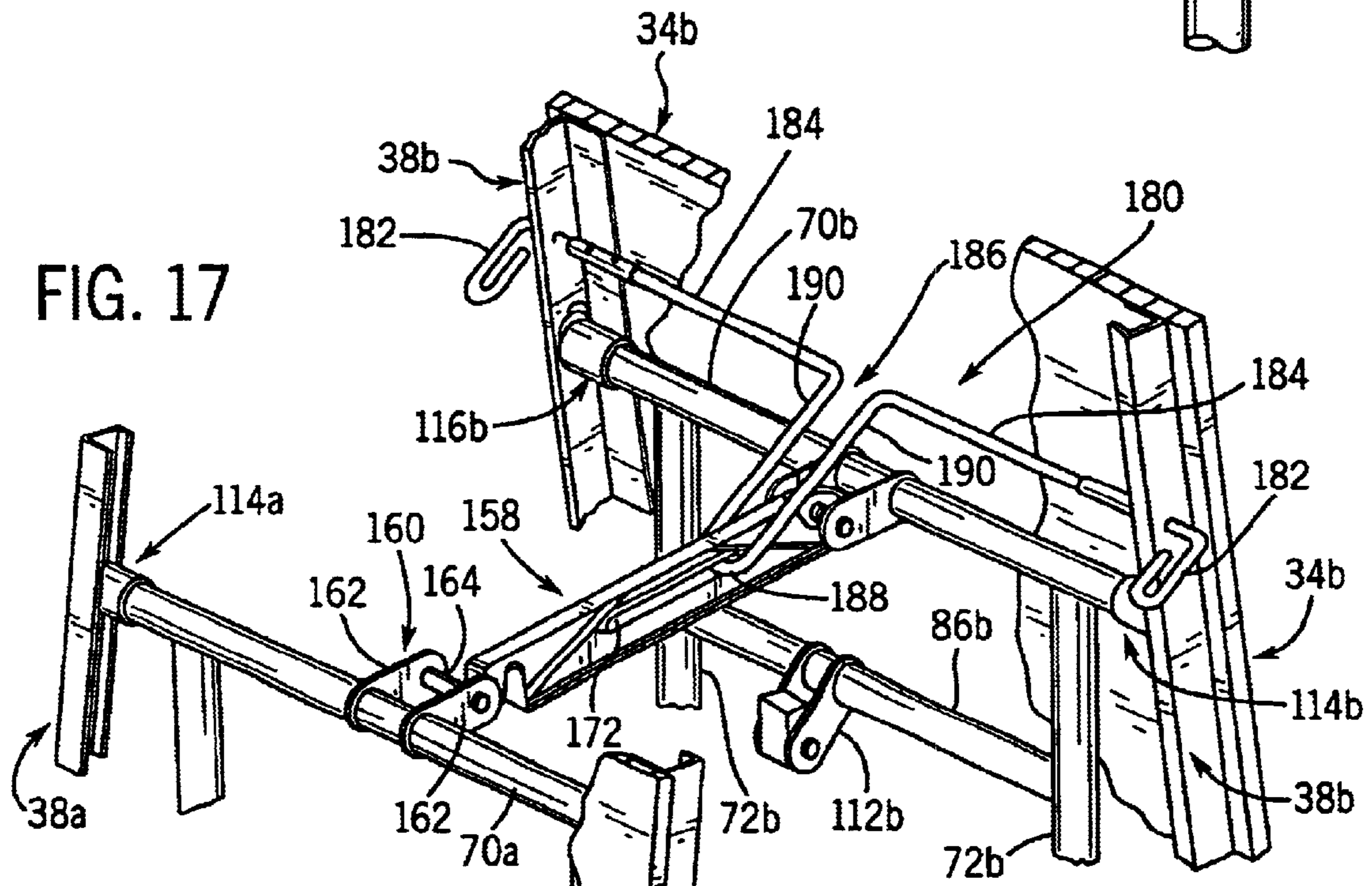
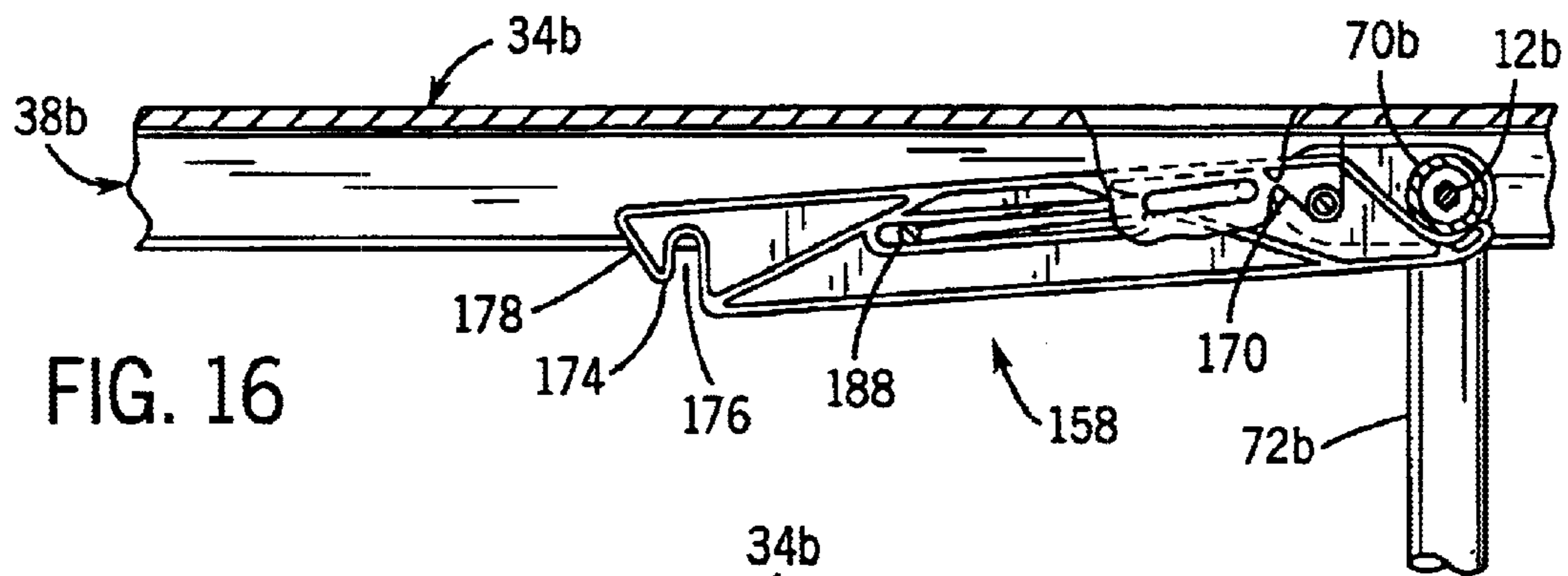

FIG. 14



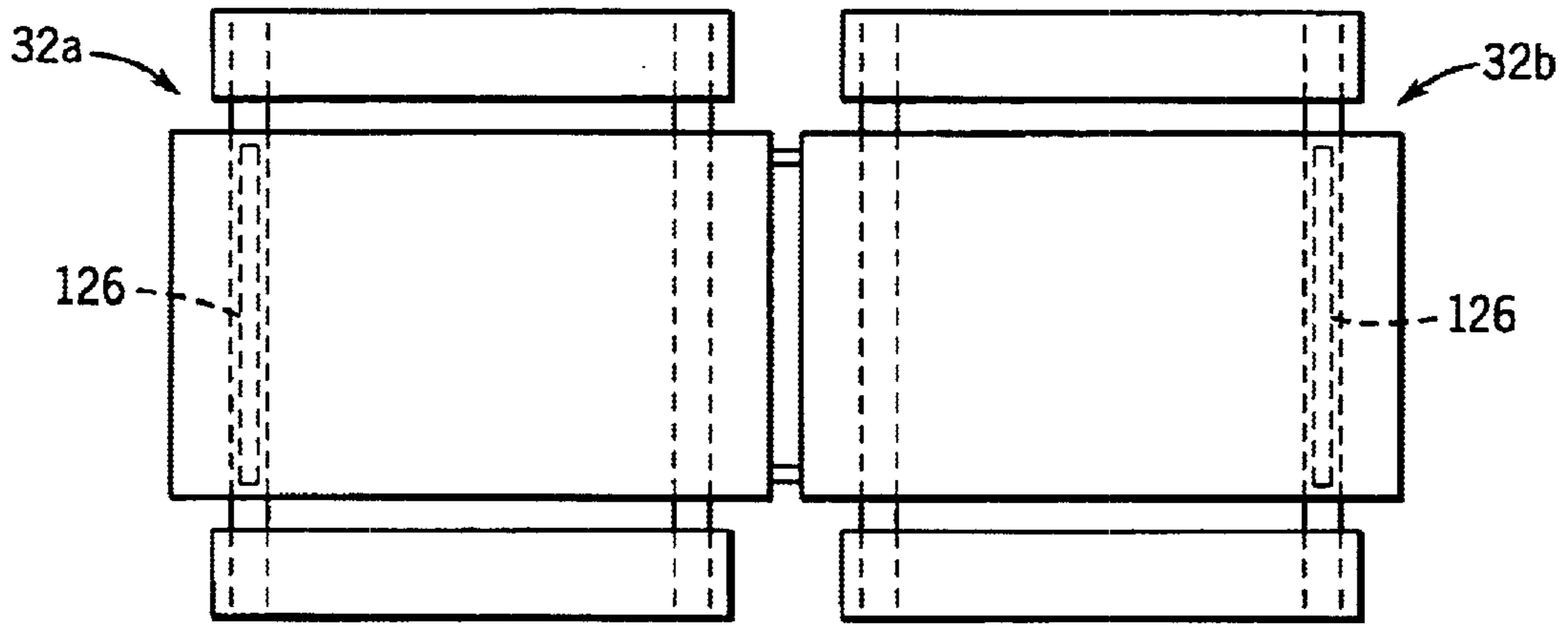

FIG. 19A

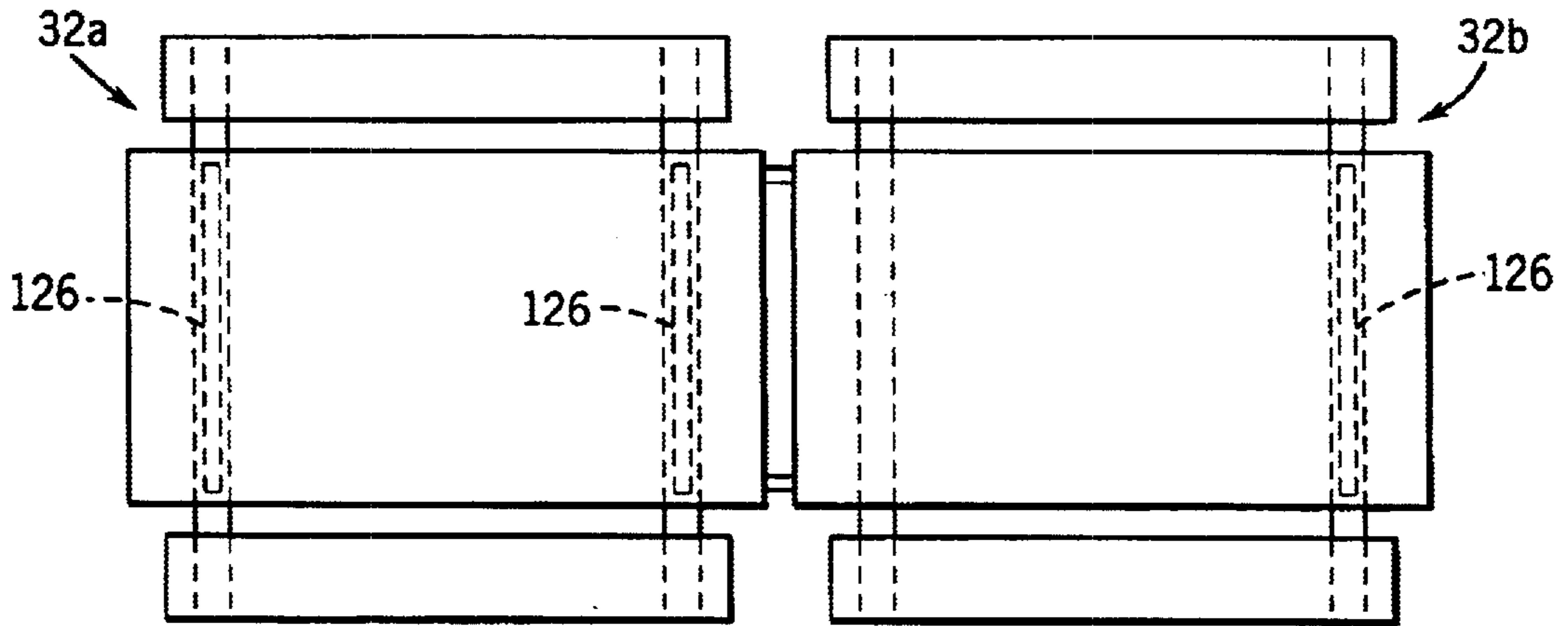

FIG. 19B

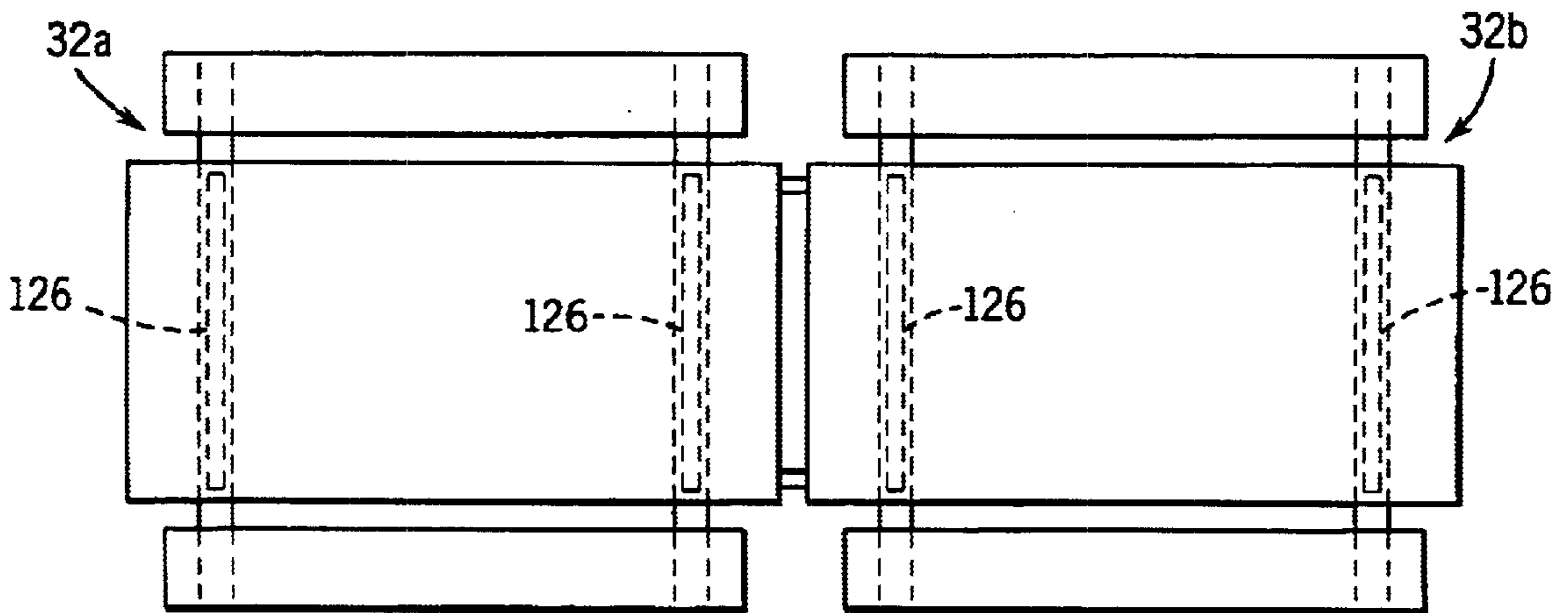

FIG. 19C

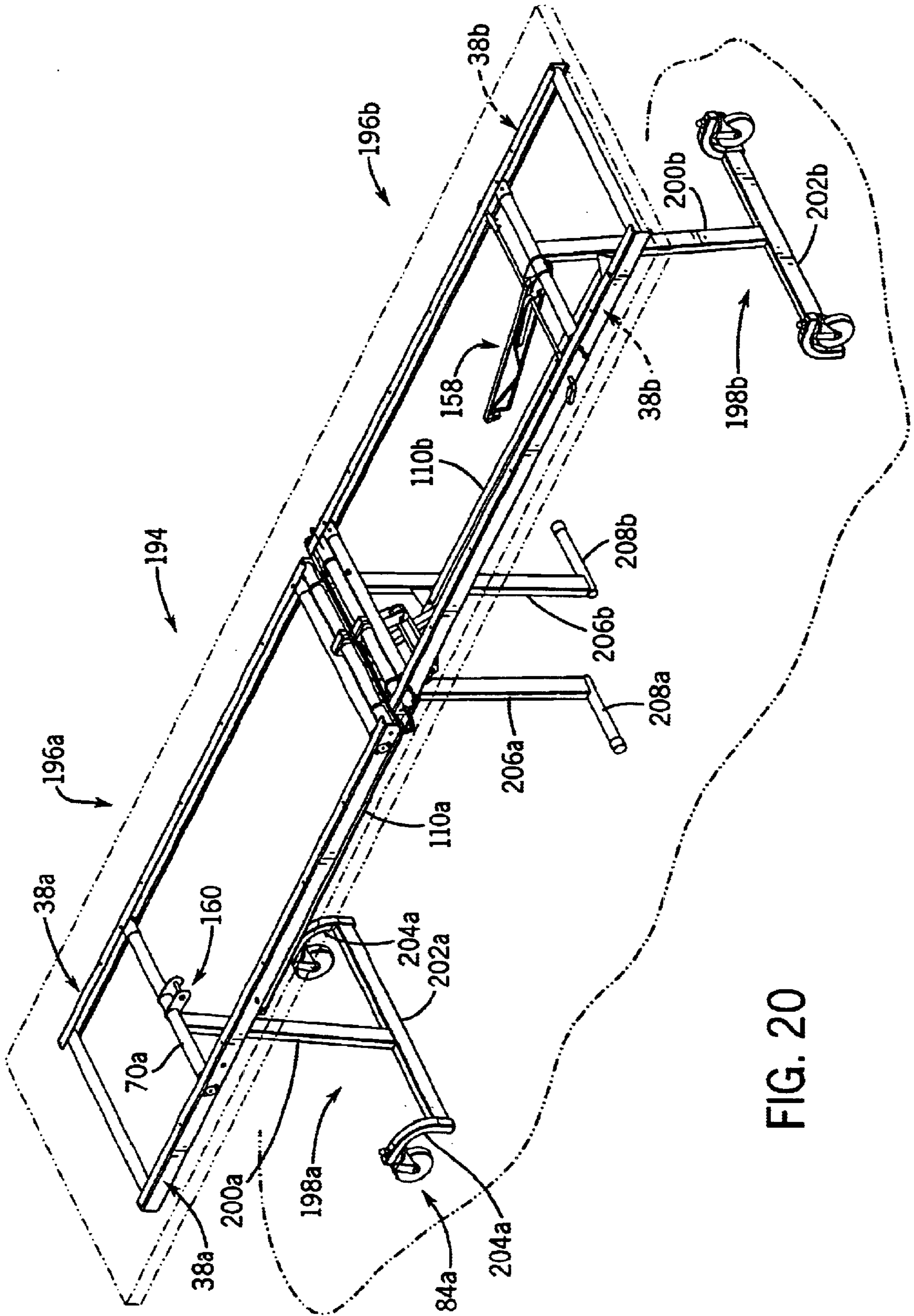
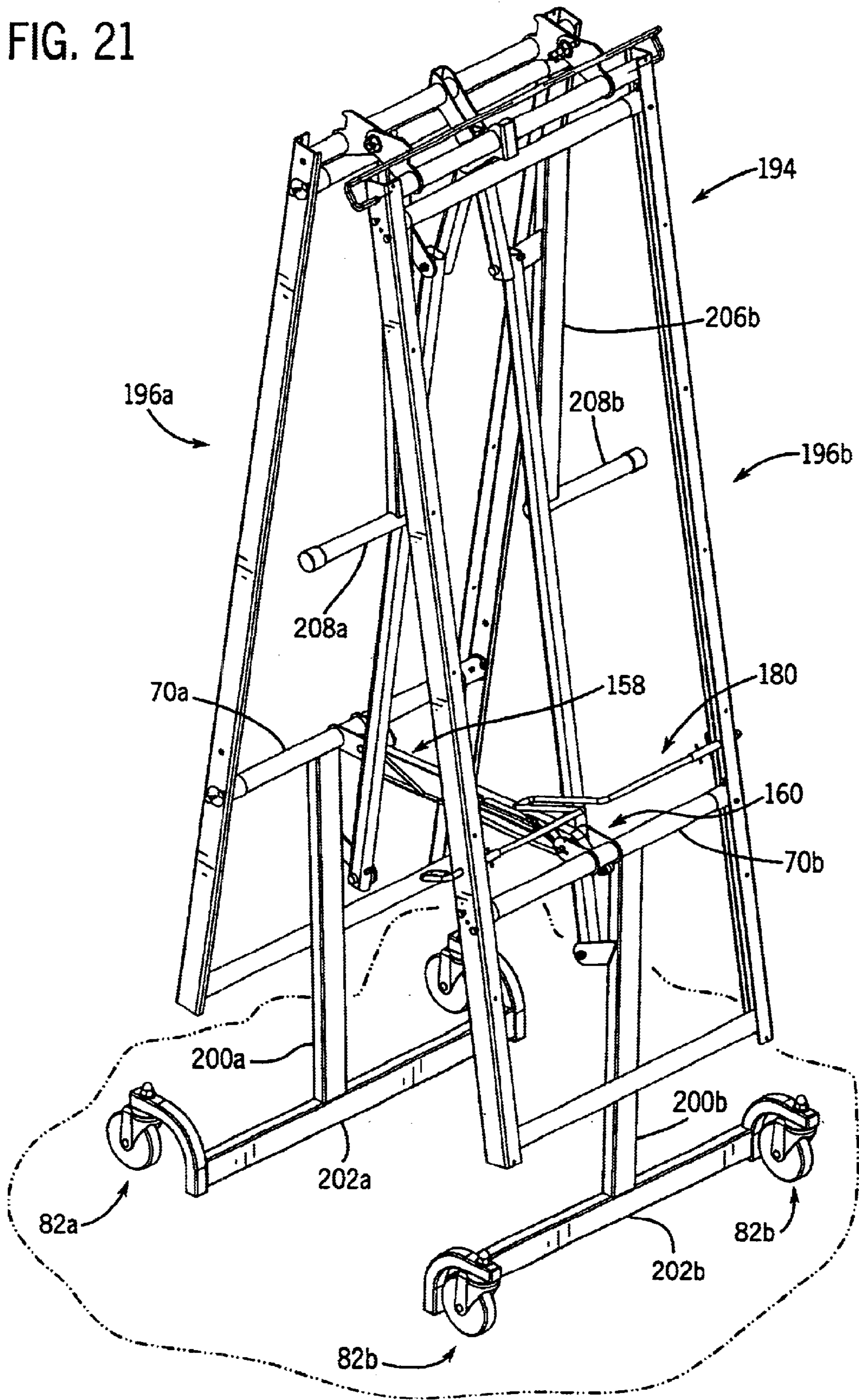

FIG. 20

FIG. 21



LATCH MECHANISM FOR FOLDING TABLE**CROSS-REFERENCE TO RELATED APPLICATION**

This application is a divisional of application Ser. No. 09/441,237 filed Nov. 16, 1999 now U.S. Pat. No. 6,223,661.

BACKGROUND AND SUMMARY OF THE INVENTION

This invention relates to tables, and more particularly to a folding rollaway table assembly in which a pair of table sections are foldably interconnected with each other and are movable between a folded, storage position and an unfolded, operative position.

Folding sectional roll-away table assemblies are commonly used in applications where table space is required on an intermittent basis. One common application is school cafeterias, gymnasiums or multi-purpose rooms, which require table space for eating or other activities at certain times, and which are often used at other times for activities which do not require table space. Folding sectional tables are commonly used in such applications, and can be quickly folded and rolled away for storage in order to clear the area for uses in which table space is not required. Typically, folding sectional tables of this type have a frame which carries a predetermined number of seats or benches, so that it is not necessary to set up and knock down chairs when table space is required.

Numerous folding table assemblies are known in the art, and various folding mechanisms and assist arrangements are known for providing movement of the table assembly between its folded, storage position and its unfolded, operative position. For example, it is known to provide one or more torsion bars interconnected with the frame or legs of the table. In the past, however, torsion bar assist assemblies have required a separate mounting arrangement interconnected with the frame, which adds to the cost and complexity of the frame.

Prior art folding sectional tables have required a user to exert an upward force on the table sections as the table sections are being lowered toward the unfolded, operative position, in order to prevent the table sections from unfolding too quickly after the table sections have attained a predetermined position during downward movement. As can be appreciated, the table sections are quite heavy, and unrestrained downward movement can cause undesirably fast opening of the table.

In addition, prior art folding sectional tables include a latch arrangement for selectively maintaining the table assembly in its folded, storage position. The latch arrangement includes a latch member located at the center of one of the table sections, which is engageable with a catch member mounted to the other of the table sections. In order to unfold the table sections, the user has been required to reach into the center of the folded table assembly and to lift or move the latch member out of engagement with the catch member. This is a somewhat complicated motion, in that the user must then withdraw his or her hand from inside the folded table assembly and operate the table assembly for movement toward its unfolded, operative position.

It is an object of the present invention to provide an improved folding sectional table assembly which is extremely easy to operate and which provides controlled movement between its unfolded, operative position and its

folded, storage position. It is a further object of the invention to provide such a table assembly which incorporates a cushioning system for providing controlled downward movement of the table assembly from its folded, storage position toward its unfolded, operative position. Yet another object of the invention is to provide such a table assembly which incorporates a unique torsion bar mounting arrangement which does not require a separate structure for interconnecting torsion bars with the table frame. Yet another object of the invention is to provide such a table assembly which combines the advantages of a torsion bar system for aiding in folding of the table assembly, and the advantages of a pneumatic cylinder arrangement for cushioning the table assembly during unfolding and for assisting in moving the table assembly away from its unfolded, operative position and toward its folded, storage position. A still further object of the invention is to provide such a table assembly which utilizes a unique latch arrangement which is easy to operate and which eliminates complicated movements in unlatching the table sections and moving the table sections away from the folded, storage position and toward the unfolded, operative position.

The invention is incorporated into a folding table assembly which includes first and second table sections, each of which includes a table top and a frame including a leg arrangement for supporting the table top above a supporting surface. Each table section further includes one or more hinge members, and the hinge members of the table sections are pivotably interconnected with each other for providing pivoting movement of the table sections between the unfolded, operative position and the folded, storage position. The leg arrangement of each table section is pivotably interconnected with the table section so as to be movable toward the table section when the table assembly is moved toward its folded, storage position, and movable away from the table top to an extended position when the table assembly is moved toward its unfolded, operative position.

In accordance with one aspect of the invention, a combination torsion bar system and pneumatic cylinder arrangement functions to assist in moving the table assembly from its folded, storage position toward its unfolded, operative position, and to cushion the table assembly during movement toward its unfolded, operative position. One or more torsion bars are interconnected with at least one of the table sections, and torque is imparted to the torsion bars as the table section is moved so as to place the table assembly in its unfolded, operative position. Energy is thus stored in the torsion bars when the table assembly is in its unfolded, operative position, and assists in moving the table assembly toward its folded, storage position when an upward force is exerted on either table section. In a preferred form, the leg arrangement includes at least one upper cross-member which is pivotable relative to the table top, and the torsion bar is mounted within an internal passage defined by the upper cross-member. In addition, at least one extendible and retractable pneumatic cylinder assembly is interconnected between one of the leg arrangements and the hinge arrangement. The pneumatic cylinder assembly is oriented such that movement of the table assembly to its folded, storage position functions to move the cylinder assembly to an extended position, and movement of the table assembly to its unfolded, operative position functions to move the cylinder assembly to a retracted position. The cylinder assembly is operable to control the rate of lowering of the table sections as the table assembly is moved to its unfolded, operative position, to ensure that the table sections are lowered at a relatively slow, controlled speed. In addition, the cylinder

assembly includes a spring for urging the cylinder assembly toward its extended position from its retracted position, to assist in raising the table sections when the table assembly is moved from its unfolded, operative position toward its folded, storage position.

In accordance with another aspect of the invention, the torsion bar system is preferably interconnected with and extends between a pair of structural apron members to which the table top is mounted. As noted above, the torsion bar is preferably received within an upper cross-member defined by the leg arrangement of a table section. The upper cross-member of the leg arrangement is pivotably mounted between the structural apron members by means of a pair of pivot hubs, one of which is mounted to each of the structural apron members. In one form, each pivot hub includes a mounting flange member adapted to be secured to the structural apron member, and a sleeve connected to the mounting flange member and extending therefrom toward the opposite structural apron member. One of a pair of ends of the upper cross-member is received within each sleeve, for pivotably mounting the leg arrangement to and between the structural apron members. A torsion bar retainer is mounted to one of the sleeves, and the torsion bar is non-rotatably engaged with the torsion bar retainer. At a location spaced from the torsion bar retainer, the torsion bar is engaged with a torsion bar driver mounted to the upper cross-member, such that pivoting movement of the upper cross-member caused by movement of the leg arrangement functions to impart torque to the torsion bar as the table section is lowered. With this arrangement, the torsion bar assist mechanism is essentially incorporated into the leg arrangement and interconnected with the structural apron members, for providing an efficient torsion bar mounting arrangement and for concealing the torsion bar system.

In accordance with another aspect of the invention, a folding sectional table incorporates a pneumatic cylinder assist and cushioning arrangement. The table sections are interconnected by means of at least one pair of hinge members which are pivotably interconnected with each other via a pivot pin. A foldable leg arrangement is located adjacent at least one of the hinge members, and an extendible and retractable pneumatic cylinder assembly is interconnected between the leg arrangement and the hinge arrangement. In a preferred form, the cylinder assembly is pivotably mounted at a first end to the hinge arrangement and at a second end to the leg arrangement. The first end of the pneumatic cylinder assembly is preferably pivotably mounted at a location coincident with the pivot axis defined by the pivot pin which pivotably interconnects the pivot members. The second end of the pneumatic cylinder assembly is pivotably interconnected with the leg arrangement. In embodiments incorporating more than one pair of hinge members, a pneumatic cylinder assembly is preferably interconnected with each pair of hinge members. The pneumatic cylinder assemblies are operable to cushion movement of the table assembly as the table assembly is moved toward its unfolded, operative position. The cylinder assemblies are especially beneficial in relatively heavy table assemblies, such as table assemblies with table tops having a relatively long length or in table assemblies incorporating fixed seating structures.

The invention further contemplates a latch arrangement for a folding sectional table assembly. The latch arrangement includes a latch member mounted to one of the table sections and a catch member mounted to the other table section. The latch member is movable between an engaged position in which the latch member engages the catch member to

maintain the table assembly in its inoperative, folded position, and a disengaged position in which the latch member is disengaged from the catch member to enable the table assembly to be moved away from its folded, storage position toward its unfolded, operative position. The latch member is preferably pivotably mounted to a cross-member located adjacent the underside of the table top, such as a cross-member associated with a leg arrangement. Movement of the latch member from its engaged position toward its disengaged position is caused by operation of an actuator member, which preferably includes an actuator area located adjacent each of a pair of opposite sides defined by the table top so as to enable operation of the latch arrangement from either side of the table assembly, without reaching between the folded table sections. The actuator member is preferably in the form of a rod pivotably mounted to and between the structural apron members at a location offset from the pivotable mounting of the latch member. The rod includes first and second engagement areas located one adjacent each of the structural apron members, with an intermediate actuating section therebetween which is engageable with the latch member. The intermediate actuating section is received within a slot defined by the latch member and is offset from the actuator areas, such that pivoting movement of the actuator member causes engagement of the actuator section with a wall of the latch member defining the slot, to move the actuator member away from its engaged position. In a preferred form, a spring is interconnected with the latch member for biasing the latch member toward its engaged position, such that the latch member automatically engages the catch member as the table assembly is moved to its folded, storage position.

The various features of the invention can be employed separately to provide advantages in operation over the prior art. In a particularly preferred form, however, the various features are combined so as to provide a table assembly with a number of advantages over the prior art.

Various other features, objects and advantages of the invention will be made apparent from the following description taken together with the drawings.

BRIEF DESCRIPTION OF THE DRAWINGS

The drawings illustrate the best mode presently contemplated of carrying out the invention.

In the drawings:

FIG. 1 is an isometric view of a folding sectional table constructed according to the invention, showing the table assembly in an unfolded, operative position;

FIG. 2 is an isometric view of the frame of the table assembly of FIG. 1 in an unfolded, operative position;

FIG. 3 is a view similar to FIG. 2, showing the frame in a folded, storage position;

FIG. 4 is a bottom plan view of the table assembly of FIG. 1;

FIG. 5 is a side elevation view of the table assembly of FIG. 1;

FIG. 6 is a partial section view taken along line 6—6 of FIG. 4;

FIG. 7 is an enlarged partial side elevation view of a hinge arrangement interconnecting the table sections of the folding table assembly of FIG. 1;

FIG. 8 is a side elevation view similar to FIG. 5, showing the table assembly in a folded, storage position;

FIG. 9 is an enlarged partial section view of the hinge arrangement of FIG. 7 in combination with a linkage

arrangement, showing the table assembly in the folded, storage position;

FIG. 10 is a partial section view taken along line 10—10 of FIG. 7;

FIG. 11 is a view similar to FIG. 7, showing operation of a locking bar for selectively retaining the table assembly in the unfolded, operative position;

FIG. 12 is an exploded partial isometric view showing the torsion bar mounting arrangement and the latch arrangement incorporated into the table assembly of FIG. 1;

FIG. 13 is a partial section view taken along line 13—13 of FIG. 12;

FIG. 14 is a partial section view taken along line 14—14 of FIG. 13;

FIG. 15 is a partial section view taken along line 15—15 of FIG. 13;

FIG. 16 is a partial side elevation view illustrating the latch member incorporated into the table assembly of FIG. 1;

FIG. 17 is a partial isometric view illustrating the latch member of FIG. 16 in combination with a catch member;

FIG. 18 is a partial section view showing operation of the latch member and catch member of FIG. 17 for maintaining the table assembly in the folded, storage position;

FIGS. 19a–19c are schematic top plan views illustrating different torsion bar configurations for a table assembly such as that of FIG. 1;

FIG. 20 is an isometric view of another embodiment of a frame for a folding sectional table constructed according to the invention, shown in an unfolded, operative position; and

FIG. 21 is a view similar to FIG. 20 showing the frame in a folded, storage position.

DETAILED DESCRIPTION OF THE INVENTION

Referring to FIGS. 1 and 2, a sectional table assembly 30 constructed according to the invention generally includes a pair of pivotable table sections 32a and 32b, which are essentially mirror images of each other and are pivotably interconnected with each other in a manner to be explained for movement between a folded, storage position and an unfolded, operative position. Except as described below, table sections 32a and 32b are identical in construction and contain identical components, and like reference characters will be used to describe the components of table sections 32a and 32b, with the modifier “a” and “b” being used to refer to components associated with table sections 32a and 32b, respectively. Except as expressly set forth hereafter, the description of table section 32a applies equally to table section 32b, and vice versa.

Table section 32a includes a table top 34a and a frame assembly 36a. Table top 34a is of conventional construction, and is secured to a pair of spaced, parallel structural apron members 38a forming a part of frame assembly 36a. Frame assemblies 36a and 36b are pivotably interconnected with each other for movement between an unfolded, operative position as shown in FIG. 2, and a folded, storage position as shown in FIG. 3.

In addition to apron members 38a, frame assembly 36a includes a pair of structural cross-members 40a extending between the ends of apron members 38a. Cross-members 40a are rigidly mounted to apron members 38a in any satisfactory manner such as by welding, to form a rigid rectangular structure to which the underside of table top 34a is secured.

Frame assembly 36a further includes an inner leg assembly 44a and an outer leg assembly 46a. Inner leg assembly 44a includes an upper horizontal tubular member 48a and a pair of depending leg members 50a, each of which is mounted at its upper end to upper horizontal tubular member 48a. Each leg member 50 includes an outwardly extending horizontal base section 52a which extends outwardly beyond the sides of table top 34a, and an intermediate cross-member 53a which extends between and is interconnected at its ends with leg members 72a. An upstanding seat support member 54a is secured to the outer end of base section 52a, and is interconnected with a seat frame 56a by means of a horizontal connector member 58a. Seat frame 56a includes a lower base member 60a interconnected with end uprights 62a and intermediate uprights 64a. A seat support plate 66a is mounted to the upper end of each of uprights 62a and 64a, and a seat member, such as a bench 68a, is interconnected with seat support plates 66a. Alternatively, it is understood that separate seats may be mounted to each of seat support plates 66a in place of bench 68a, when individual seats are desired.

Outer leg assembly 46a is constructed similarly to inner leg assembly 44a, including an upper horizontal tubular member 70a and a pair of depending leg members 72a. A base section 74a is interconnected with and extends outwardly from the lower end of each depending leg member 72a. A seat support member 76a is mounted to the outer end of each base section 74a, extending upwardly therefrom and interconnected with seat frame 56a via a connector member 78a. A lower cross-brace member 80a extends between and interconnects base sections 74a, and is connected at each end to seat support member 76a below base section 74a. A caster assembly 82a is interconnected with each seat support member 76a via a caster mounting bracket 84a. An intermediate cross-member 86a extends between and is interconnected at its ends with leg members 72a.

Referring to FIGS. 3 and 5–7, a pair of hinge plates 90a are rigidly mounted to the inner one of cross-members 40a of frame assembly 36a. Similarly, a pair of hinge plates 90b are rigidly mounted to the inner one of cross-members 40b of frame assembly 36b. Each hinge plate 90a is located adjacent one of hinge plates 90b, with each such set of hinge plates being located adjacent one side of table assembly 30. A hinge pin 94, in the form of a bolt or the like, extends through aligned openings in hinge plates 90a and 90b. Hinge pins 94 define a pivot axis about which frame assembly 36a and 36b are pivotable relative to each other, for providing pivoting movement between the unfolded, operative position of FIGS. 1, 2, 4 and 5, and the folded, storage position of FIGS. 3 and 8.

Referring to FIG. 7, hinge plate 90a includes an upper edge from which a tab 96a extends upwardly. Similarly, hinge plate 90b defines an upper edge from which a tab 96b extends upwardly. When table assembly 30 is in its unfolded, operative position, tabs 96a and 96b are spaced slightly apart from each other. A locking rod 98 is pivotably interconnected with apron members 38b of table section 32b via end mounting sections 100. When table assembly 30 is in its unfolded, operative position, locking rod 98 is located in the space between tabs 96a and 96b, for preventing inadvertent movement of frame assemblies 36a and 36b away from the unfolded, operative position in the event an inadvertent upward force is applied to either frame assembly. As shown in FIG. 10, each end mounting section 100 includes an inwardly extending mounting shaft section 102 which extends through an opening in one of apron members 38b, for providing pivoting movement of locking rod 98

about a pivot axis defined by mounting shaft sections **102**. As shown in FIG. **11**, locking rod **98** is movable out of the space between tabs **96a** and **96b**, for allowing relative movement between hinge plates **90a** and **90b** in order to enable table sections **32a** and **32b** to be moved away from the unfolded, operative position toward the folded, storage position.

As shown in FIG. **6**, upper bars **104a**, **104b** are rigidly mounted to cross-members **40a**, **40b**, respectively. Lower bars **106a**, **106b** are rigidly mounted to intermediate cross-members **53a**, **53b**, respectively. A link **108a** is pivotably mounted at an upper end to upper bar **104a**, and is pivotably mounted at a lower end to lower bar **106b**. Similarly, a link **108b** is pivotably mounted at an upper end to upper bar **104b** and at a lower end to lower bar **106a**. A tie bar **110a** is pivotably mounted at an inner end to lower bar **106a** and link **108b**, and is pivotably mounted at an outer end to a tab **112a** (FIG. **5**) secured to intermediate cross-member **86a**. Similarly, tie bar **110b** is pivotably mounted at an inner end to lower bar **106b** and link **108a**, and at an outer end to a tab **112b** secured to intermediate cross-member **86b**.

Referring to FIG. **2**, upper horizontal tubular member **48a** of inner leg assembly **44a** is interconnected with apron members **38a** via hub assemblies **114a**, **116a**. Similarly, hub assemblies **114a** and **116a** are interposed between upper horizontal tubular member **70a** of outer leg assembly **46a** and apron members **38a**.

As shown in FIGS. **13–15**, hub assembly **114a** includes a mounting flange member **118a** and a sleeve **120a** secured to mounting flange member **118a**. Similarly, hub assembly **116a** includes a mounting flange member **122a** and a sleeve **124a** secured thereto. One end of upper horizontal tubular member **70a** is received within sleeve **120a**, and the opposite end of upper horizontal tubular member **70a** is received within sleeve **124a**. Upper horizontal tubular member **70a** is pivotable relative to sleeves **120a** and **124a**, so as to provide pivoting movement of outer leg assembly **46a** relative to apron members **38a** and table top **34a**. Upper horizontal tubular member **48a** of inner leg assembly **44a** is mounted to hub assemblies **114a** and **116a** at the inner ends of apron members **38a** in the same manner, for providing pivoting movement of inner leg assembly **44a** relative to apron members **38a** and table top **34a**.

Referring to FIG. **13**, upper horizontal tubular member **70a** defines an internal passage within which a torsion bar **126** is received. A torsion bar retainer **128** is mounted to mounting flange member **118a**, extending inwardly therefrom within the passage defined by sleeve **120a**. A torsion bar driver **130** is mounted within the internal passage defined by upper horizontal tubular member **70a** in the vicinity of sleeve **124a**, opposite torsion bar retainer **128**. Torsion bar **126** defines a non-circular cross-section, such as a hexagonal cross-section as illustrated, and torsion bar retainer **128** includes a mating non-circular passage **132** within which one end of torsion bar **126** is received, for non-rotatably mounting torsion bar **126** to hub assembly **114a**. Torsion bar driver **130** similarly defines an opening having a non-circular cross-section corresponding to that of torsion bar **126**. With this arrangement, pivoting movement of outer leg assembly **46a** relative to structural apron members **38a** upon movement of table sections **32a**, **32b** toward the unfolded, operative position functions to twist torsion bar **126** so as to store energy, which assists in raising table sections **32a**, **32b** when moving table sections **32a**, **32b** away from the unfolded, operative position toward the folded, storage position.

Each apron member **38a** defines a web **136a**, an upper flange **138a** and a lower flange **140a**. Mounting flange **118a**

of hub assembly **114a** defines a pair of threaded passages, and threaded fasteners such as screws **142** extend through openings in apron web **136a** and into the threaded passages of mounting flange member **118a** for securing hub assembly **114a** in position relative to apron member **38a**. Similarly, mounting flange member **122a** of hub assembly **116a** includes a pair of threaded passages, and threaded fasteners such as screws **142** extend through openings in web **136a** and into the threaded passages of mounting flange member **122a** for securing hub assembly **116a** in position relative to apron member **38a**. With this arrangement, the presence of a torsion bar assist mechanism is concealed between apron members **38a**, for simplifying assembly and for providing a more aesthetically desirable torsion bar mounting arrangement.

Referring to FIG. **6**, a pneumatic cylinder assembly **146a** is interconnected between one of depending leg members **50a** and one set of hinge plates **90a**, **90b**. Pneumatic cylinder assembly **146a** includes a cylinder **148a** and a rod **150a**. Cylinder **148a** is pivotably interconnected with hinge plates **90a**, **90b** at hinge pin **94**, and rod **150a** is pivotably mounted to leg member **50a** by a tab **152a** and a pivot pin **154a**. Similarly, cylinder assembly **146b** is interconnected in the same manner between one of depending leg members **50b** and the other set of hinge plates **90a**, **90b**. Cylinder assemblies **146a**, **146b** are pneumatic cushioning cylinder assemblies which are spring biased toward an extended position, such as is available from Suspa of Grand Rapids, Mich. under Part Nos. 37-3351, 37-3352, 37-3353, 37-3354 and 37-3355, selected according to the size and weight of the components of table assembly **30**.

FIGS. **16–18** illustrate a latch arrangement for selectively maintaining table assembly **30** in its folded, storage position of FIGS. **3** and **8**. Generally, the latch arrangement includes a latch member **158** and a catch member **160**. Catch member **160** includes a pair of tabs **162** rigidly mounted to upper horizontal tubular member **70a** of frame assembly **36a**. A catch rod **164** extends between and is mounted at its ends to tabs **162**.

Latch member **158** is pivotably mounted at an inner end to a pivot pin **166** which extends between a pair of tabs **168** rigidly fixed to upper horizontal tubular member **70b** of frame assembly **36b**. Pivot pin **166** extends through a torsion spring **170**, which is interconnected between one of tabs **168** and latch member **158** for biasing latch member **158** downwardly, or counterclockwise with reference to FIGS. **16–18**. Latch member **158** includes an axially extending slot **172**, and a hook **174** at its outer end defining a notch **176**. A ramped end edge **178** is located outwardly of hook **174**.

An actuator member, shown generally at **180**, is interconnected between actuator member **158** and apron members **38b** for pivoting actuator member **158** upwardly or counterclockwise about pivot pin **166**. Actuator member **180** includes a pair of end actuator areas **182**, each of which is located outwardly of one of apron members **38b**. A mounting section **184** extends inwardly from each end actuator area **182** through an opening formed in each apron member **38b** for providing pivoting movement of actuator member **180** relative to apron members **38b**. Actuator member **180** further includes a central area **186** including an actuator section **188**, which extends parallel to mounting sections **184**, and a pair of connector sections **190** which extend between actuator section **188** and mounting sections **184**. With this construction, actuator section **188** is laterally offset from the pivot axis of actuator member **180** as defined by the longitudinal axes of mounting sections **184**.

Actuator section **188** is disposed within slot **172** of latch member **158**. Upon manual engagement of either of end

actuator areas **182** and manipulation thereof so as pivot actuator member **180** in a clockwise direction as shown in phantom in FIG. **18**, actuator section **188** of actuator member **180** engages the upper wall of slot **172** for moving latch member **158** in a clockwise direction about pivot pin **166**, to a position in which latch member **158** is disengaged from catch rod **164**. Releasing end engagement areas **182** of actuator member **180** causes counterclockwise pivoting movement of latch member **158** and actuator member **180** under the influence of torsion spring **170**.

In operation, table assembly **30** functions as follows. When table assembly is in its folded, storage position, the user manipulates end actuator areas **182** of actuator member **180** to disengage latch member **158** from catch rod **164** as described above. The user then exerts a downward force on either or both of table sections **32a** or **32b**, which causes table sections **32a** and **32b** to pivot about pivot pins **94** away from the folded, storage position. This movement causes caster assemblies **82a**, **82b** to move outwardly away from each other, and table sections **32a**, **32b** are lowered toward the floor or other supporting surface. During such downward movement of table sections **32a**, **32b**, tie bars **110a**, **110b** function to bring inner leg assemblies **44a**, **44b** downwardly and to maintain a parallel relationship between inner leg assemblies **44a**, **44b** and outer leg assemblies **46a**, **46b**, respectively. During such downward movement of table sections **32a**, **32b**, torsion is applied to torsion bars **126** by torsion bar drivers **130**, to store energy in torsion bars **126** tending to resist such downward movement. However, the weight of the components of table sections **32a**, **32b** overcomes any such resistance, such that table sections **32a**, **32b** continue to be lowered toward the floor.

As table sections **32a**, **32b** approach the fully lowered position of FIG. **2**, pneumatic cylinder assemblies **146a**, **146b** function to cushion such downward movement of table sections **32a**, **32b** by the cushioning properties of cylinder assemblies **146a**, **146b**, in order to prevent the rapid downward movement of table sections **32a**, **32b** which may otherwise occur. Cylinder assemblies **146a**, **146b** function to gradually lower table sections **32a**, **32b** by gravity or with the assistance of an operator, although the cushioning properties of cylinder assemblies **146a**, **146b** prevent movement beyond a predetermined rate. As table sections **32a**, **32b** are moved together, locking rod **98** is received between tabs **96** for maintaining table sections **32a**, **32b** in the unfolded, operative position of FIG. **2**.

When it is desired to raise table assembly **30** for folding and storage purposes, the user manipulates end mounting sections **100** of locking rod **98** to move locking rod **98** upwardly from between tabs **96**, as shown in phantom in FIG. **11**. The user then applies an upward force on either or both of table sections **32a**, **32b**, causing pivoting movement about hinge pins **94**. Hydraulic cylinder assemblies **146a**, **146b**, which are spring biased toward an extended position, assist in such movement, as do torsion bars **126**. With this arrangement, the dual assist provided by hydraulic cylinder assemblies **146a**, **146b** and torsion bars **126**, makes it relatively easy to lift table sections **32a**, **32b**, to significantly ease the burden on a user in moving table sections **32a**, **32b** to the folded, storage position.

As table sections **32a**, **32b** approach the folded, storage position, angled end edge **178** of latch member **158** approaches catch rod **164** of catch member **160**. Continued movement of table sections **32a**, **32b** together results in engagement of angled end edge **178** with catch rod **164**, such that latch member **158** is pivoted in a clockwise direction until catch rod **164** clears hook **174** of latch member **158**.

When this occurs, latch member **158** is moved in a counterclockwise direction under the influence of torsion spring **170**, to engage catch rod **164** within notch **176**. With this arrangement, engagement of latch member **158** with catch member **160** functions to retain table sections **32a**, **32b** together in the folded, storage position.

When it is desired to subsequently move table sections **32a**, **32b** to the unfolded, operative position, the user manipulates end actuator areas **182** of actuator member **180**, from either side of table assembly **30**, so as to rotate latch member **158** clockwise and to disengage catch rod **164** from notch **176**. Once table sections **32a**, **32b** are moved slightly apart, the user releases engagement with the end actuator area **182** and moves table sections **32a**, **32b** downwardly as described above.

Referring to FIGS. **19a–19c**, it can be appreciated that any number of torsion bars **126** may be incorporated into a table assembly. Referring to FIG. **19a**, a table assembly **30** incorporates two torsion bars **126** and associated hub mounting arrangements, with each torsion bar **126** being associated with an outer leg assembly. FIG. **19a** illustrates two torsion bars **126**, FIG. **19b** illustrates three torsion bars **126**, and FIG. **19c** illustrates four torsion bars **126**. FIGS. **19a–19c** illustrate table sections **32a**, **32b** schematically, and it is understood that more torsion bars **126** are used for larger table sections **32a**, **32b** or table sections with fixed seating, and fewer torsion bars **126** are used with smaller table sections **32a**, **32b** or table sections without fixed seating.

When an upper horizontal tubular member, such as **48**, **70**, does not include a torsion bar **126**, the upper horizontal tubular member is pivotably mounted between the apron sections, such as **38a**, in the same manner as shown and described above, i.e. utilizing hub assemblies such as **114**, **116**. Torsion bar **126** is omitted, as are torsion bar retainer **128** and torsion bar driver **130**. In all other respects, however, the pivotable mounting of the leg arrangement is the same as shown and described previously.

FIGS. **20** and **21** illustrate a folding sectional table assembly **194** which includes a pair of table sections **196a**, **196b** pivotably interconnected together for movement between an unfolded, operative position of FIG. **20** and a folded, storage position of FIG. **21**. Table sections **196a** and **196b** are generally similar in construction to table sections **32a**, **32b**, respectively, and like reference characters will be used where possible to facilitate clarity. Table sections **196a**, **196b** differ from table sections **32a**, **32b**, respectively, in that table sections **196a**, **196b** have a somewhat different leg structure and do not include a seat frame such as **56** and associating seating components.

Table section **196a** includes an outer leg assembly **198a** which includes a central leg member **200a** and a lower base member **202a**. A caster assembly **84a** is mounted to each of a pair of caster mounting arms **204a**, each of which is secured to an end of lower base member **202a**. The upper end of central leg member **200a** is rigidly fixed to upper horizontal tubular member **70a**, and is pivotable therewith relative to apron members **38a**.

An inner leg member **206a** is mounted to upper horizontal tubular member **48a**, and a foot **208a** is mounted to the lower end of leg member **206a**. Leg members **200a**, **206a** are interconnected together via tie bar **110a**, and a linkage arrangement similar to that illustrated in FIG. **6** is interconnected between the frame assembly of each table section and the inner leg member **206** and tie bar **110** of the opposite table section.

Because table assembly **194** does not include any seating components, the overall weight of table assembly **194** is

significantly less than that of a table assembly such as **30**. Due to this lesser weight, table assembly **194** does not incorporate pneumatic cylinder assemblies such as **146**, since the lesser weight of the table sections **196a**, **196b** has been found to be more easily managed by a user in lowering table sections **196a**, **196b** in lowering and raising table sections **196a**, **196b**. In all other respects, however, construction and operation of table assembly **194** is the same as described previously with respect to table assembly **30**.

It can thus be appreciated that the folding sectional table assembly of the present invention incorporates a number of features which enhance operation and assembly. The combination of pneumatic cylinders and torsion bars greatly enhances operation of heavy table assemblies such as those which include seats, both in cushioning downward movement of the table sections to the unfolded, operative position and in raising of the table sections for movement toward the folded, storage position. The torsion bar mounting arrangement is combined with the pivotable leg mounting, so as to conceal the torsion bar arrangement and to simplify assembly. In addition, the same basic leg mounting arrangement is used for all leg assemblies, and torsion bars can be selectively employed in desired ones of the leg assemblies according to the overall weight of the table sections. The pneumatic cylinder assemblies act directly at the hinge point between the table sections, providing efficient and effective cushioning and assist during lowering and raising of the table sections. The latch arrangement provides a convenient and reliable mechanism for automatic engagement as the table sections are moved toward the folded, storage position, and can be accessed from either side of the table for disengaging the latch member when it is desired to lower the table sections.

Various alternatives and embodiments are contemplated as being within the scope of the following claims particularly pointing out and distinctly claiming the subject matter regarded as the invention.

I claim:

1. A latch arrangement for a folding table assembly including first and second table sections, each of which defines an inner end and an outer end, wherein the table sections are pivotably interconnected at their inner ends via a pivot arrangement for movement of the table assembly between a folded, storage position and an unfolded, operative position, wherein each table section includes a table top and a frame including a leg arrangement for supporting the table top above a supporting surface, comprising:

a movable latch member mounted to the first table section, wherein the movable latch member is separate from the pivot arrangement and is mounted to the first table section at a location outwardly of the pivot arrangement, wherein the latch member is moveable between an engaged position and a disengaged position;

a stationary catch member mounted to the second table section, wherein the stationary catch member is separate from the pivot arrangement and is mounted to the second table section at a location outwardly of the pivot arrangement;

wherein the latch member and the catch member are configured and positioned on the first and second table sections, respectively, such that the latch member is moved to its engaged position in engagement with the stationary catch member as the table assembly is moved to its folded, storage position from its unfolded, operative position, wherein engagement of the latch

member with the catch member functions to maintain the table assembly in its folded, storage position; and a latch member actuator interconnected with the latch member for selectively moving the latch member from its engaged position to its disengaged position out of engagement with the catch member to enable the table assembly to be moved from its folded, storage position to its unfolded, operative position.

2. The latch arrangement of claim **1**, wherein the leg arrangement of each table section includes an upper cross-member spaced outwardly from the inner end of the table section, wherein the movable latch member is mounted to the upper cross-member of the first table section and the stationary catch member is mounted to the upper cross-member of the second table section.

3. The latch arrangement of claim **2**, wherein the latch member is pivotably interconnected with the upper cross-member of the first table section for movement about a pivot axis between its engaged position and its disengaged position.

4. The latch arrangement of claim **3**, wherein the latch member actuator is adapted for manual engagement by a user, and includes a first manually engageable actuator area located adjacent a first side defined by the table top and a second manually engageable actuator area located adjacent a second side defined by the table top, whereby the latch member actuator is manually movable from its engaged position to its disengaged position by manual engagement with one of the actuator areas from either side of the table top.

5. The latch arrangement of claim **4**, wherein the first table section includes a pair of structural apron members to which the table top is mounted, and wherein the cross-member and the latch member actuator are pivotably mounted to and extend between the structural apron members.

6. The latch arrangement of claim **5**, wherein the cross-member and the latch member are pivotably mounted to the structural apron members at locations offset from each other.

7. The latch arrangement of claim **6**, wherein the latch member defines a slot at a location spaced from the pivot axis about which the latch member is pivotable, and wherein the latch member actuator defines an actuator section received within the slot and movable in response to manual movement of the first and second actuator areas, wherein movement of the actuator section caused by movement of the actuator areas results in engagement of the actuator section with a wall of the latch member defining the slot, for causing pivoting movement of the latch member away from its engaged position.

8. The latch arrangement of claim **7**, further comprising a spring for biasing the latch member toward its engaged position, wherein engagement of the actuator section with the wall of the latch member defining the slot exerts a force in opposition to a force exerted by the spring for moving the latch member away from its engaged position.

9. The latch arrangement of claim **7**, wherein the latch member actuator comprises a rod having first and second end portions defining the first and second actuator areas, respectively, and an intermediate portion located between the first and second end portions and offset therefrom, wherein the intermediate portion defines the actuator section and is received within the slot and is movable therewithin in response to pivoting movement of the first and second end portions, so as to move the latch member away from its engaged position toward its disengaged position.

10. In a folding table assembly including first and second table sections, each of which defines an inner end and an

outer end, wherein the table sections are pivotably interconnected at their inner ends via a pivot arrangement for movement of the table assembly between a folded, storage position and an unfolded, operative position, wherein each table section includes a table top defining a pair of spaced sides, and a frame for supporting the table top above a supporting surface, the improvement comprising:

a catch member mounted to one of the table sections, wherein the catch member is separate from the pivot arrangement and is mounted to said one of the table sections at a location outwardly of the pivot arrangement; and

a latch member mounted to the other of the table sections, wherein the latch member is separate from the pivot arrangement and is mounted to said other of the table sections at a location outwardly of the pivot arrangement, wherein the latch member is movable between an engaged position in which the latch member engages the catch member for maintaining the table assembly in its folded, storage position, and a disengaged position in which the latch member is disengaged from the catch member for allowing the table assembly to be moved from its folded, storage position toward its unfolded, operative position, wherein the latch member is movable between its engaged and disengaged positions by operation of an actuator member including first and second actuator areas, each of which is located adjacent one of the sides of the table top for enabling a user to move the latch member from its engaged position toward its disengaged position from either side of the table top.

11. A latch arrangement for a folding table assembly including first and second table sections, each of which defines an inner end and an outer end, wherein the table sections are pivotably interconnected at their inner ends for movement of the table assembly between a folded, storage position and an unfolded, operative position, wherein each table section includes a table top and a frame including a leg arrangement for supporting the table top above a supporting surface, comprising:

a movable latch member mounted to the first table section, wherein the leg arrangement of each table section includes an upper cross-member spaced from the inner end of the table section, wherein the movable latch member is mounted to the upper cross-member of the first table section;

a stationary catch member mounted to the upper cross-member of the second table section;

wherein the latch member is pivotably mounted to the upper cross-member of the first table section for movement about a pivot axis between an engaged position in which the latch member is engaged with the catch member, and a disengaged position in which the latch member is disengaged from the catch member, wherein

the moveable latch member is engageable with the stationary catch member as the table assembly is moved to its folded, storage position from its unfolded, operative position, wherein engagement of the latch member with the catch member functions to maintain the table assembly in its folded, storage position; and

a latch member actuator interconnected with the latch member, wherein the latch member actuator is adapted for manual engagement by a user, and includes a first manually engageable actuator area located adjacent a first side defined by the table top and a second manually engageable actuator area located adjacent a second side defined by the table top, whereby the latch member actuator is manually movable from its engaged position to its disengaged position by manual engagement with one of the actuator areas from either side of the table top;

wherein the first table section includes a pair of structural apron members to which the table top is mounted, and wherein the cross-member and the latch member actuator are pivotably mounted to and extend between the structural apron members.

12. The latch arrangement of claim **11**, wherein the cross-member and the latch member are pivotably mounted to the structural apron members at locations offset from each other.

13. The latch arrangement of claim **12**, wherein the latch member defines a slot at a location spaced from the pivot axis about which the latch member is pivotable, and wherein the latch member actuator defines an actuator section received within the slot and movable in response to manual movement of the first and second actuator areas, wherein movement of the actuator section caused by movement of the actuator areas results in engagement of the actuator section with a wall of the latch member defining the slot, for causing pivoting movement of the latch member away from its engaged position.

14. The latch arrangement of claim **13**, further comprising a spring for biasing the latch member toward its engaged position, wherein engagement of the actuator section with the wall of the latch member defining the slot exerts a force in opposition to a force exerted by the spring for moving the latch member away from its engaged position.

15. The latch arrangement of claim **14**, wherein the latch member actuator comprises a rod having first and second end portions defining the first and second actuator areas, respectively, and an intermediate portion located between the first and second end portions and offset therefrom, wherein the intermediate portion defines the actuator section and is received within the slot and is movable therewithin in response to pivoting movement of the first and second end portions, so as to move the latch member away from its engaged position toward its disengaged position.