



US006638834B2

(12) **United States Patent**
Gonzalez

(10) **Patent No.:** **US 6,638,834 B2**
(45) **Date of Patent:** **Oct. 28, 2003**

(54) **METHODS OF FORMING SEMICONDUCTOR CONSTRUCTIONS**

(75) Inventor: **Fernando Gonzalez**, Boise, ID (US)

(73) Assignee: **Micron Technology, Inc.**, Boise, ID (US)

(*) Notice: Subject to any disclaimer, the term of this patent is extended or adjusted under 35 U.S.C. 154(b) by 0 days.

(21) Appl. No.: **10/271,888**

(22) Filed: **Oct. 15, 2002**

(65) **Prior Publication Data**

US 2003/0059999 A1 Mar. 27, 2003

Related U.S. Application Data

(62) Division of application No. 09/592,604, filed on Jun. 12, 2000.

(51) **Int. Cl.**⁷ **H01L 31/00**

(52) **U.S. Cl.** **438/455**

(58) **Field of Search** 438/205, 197, 438/199, 202

(56) **References Cited**

U.S. PATENT DOCUMENTS

- 4,891,329 A 1/1990 Reisman et al.
- 5,298,449 A 3/1994 Kikuchi
- 5,374,564 A 12/1994 Bruel
- 5,374,581 A 12/1994 Ichikawa et al.
- 5,855,693 A 1/1999 Murari et al.
- 5,877,070 A 3/1999 Goesele et al.
- 5,882,987 A 3/1999 Srikrishnan
- 5,894,152 A 4/1999 Jaso et al.
- 5,953,622 A 9/1999 Lee et al.

- 5,998,847 A 12/1999 Assaderaghi et al.
- 6,004,406 A 12/1999 Kobayashi et al.
- 6,083,324 A 7/2000 Henley et al.
- 6,150,031 A 11/2000 Yonehara
- 6,245,161 B1 6/2001 Henley et al.
- 6,251,754 B1 6/2001 Ohshima et al.
- 6,309,945 B1 10/2001 Sato et al.
- 6,384,439 B1 5/2002 Walker
- 6,423,992 B2 7/2002 Fukuda et al.

OTHER PUBLICATIONS

Gösele, U. et al., "Semiconductor Wafer Bonding: Science, Technology, and Applications", Electrochemical Society Proceedings vol. 97-36, (©1998), pp. 400-425, 436-445.

Primary Examiner—Hoai Ho

Assistant Examiner—Thao P Le

(74) *Attorney, Agent, or Firm*—Wells St. John P.S.

(57) **ABSTRACT**

The invention includes a method of forming a semiconductor construction. A first substrate is provided which comprises silicon-containing structures separated from one another by an insulative material. The silicon-containing structures define an upper surface. A second semiconductor substrate is provided which comprises a monocrystalline material having a damage region therein. The second semiconductor substrate is bonded to the silicon-containing structures of the first substrate at the upper surface. The monocrystalline material is then cleaved along the damage region. The invention also encompasses a semiconductor construction comprising a first substrate having silicon-containing structures separated from one another by an insulative material, and a second substrate comprising a monocrystalline material. The silicon-containing structures of the first substrate define an upper surface, and the monocrystalline material of the second substrate is bonded over the silicon-containing structures at the upper surface.

16 Claims, 7 Drawing Sheets

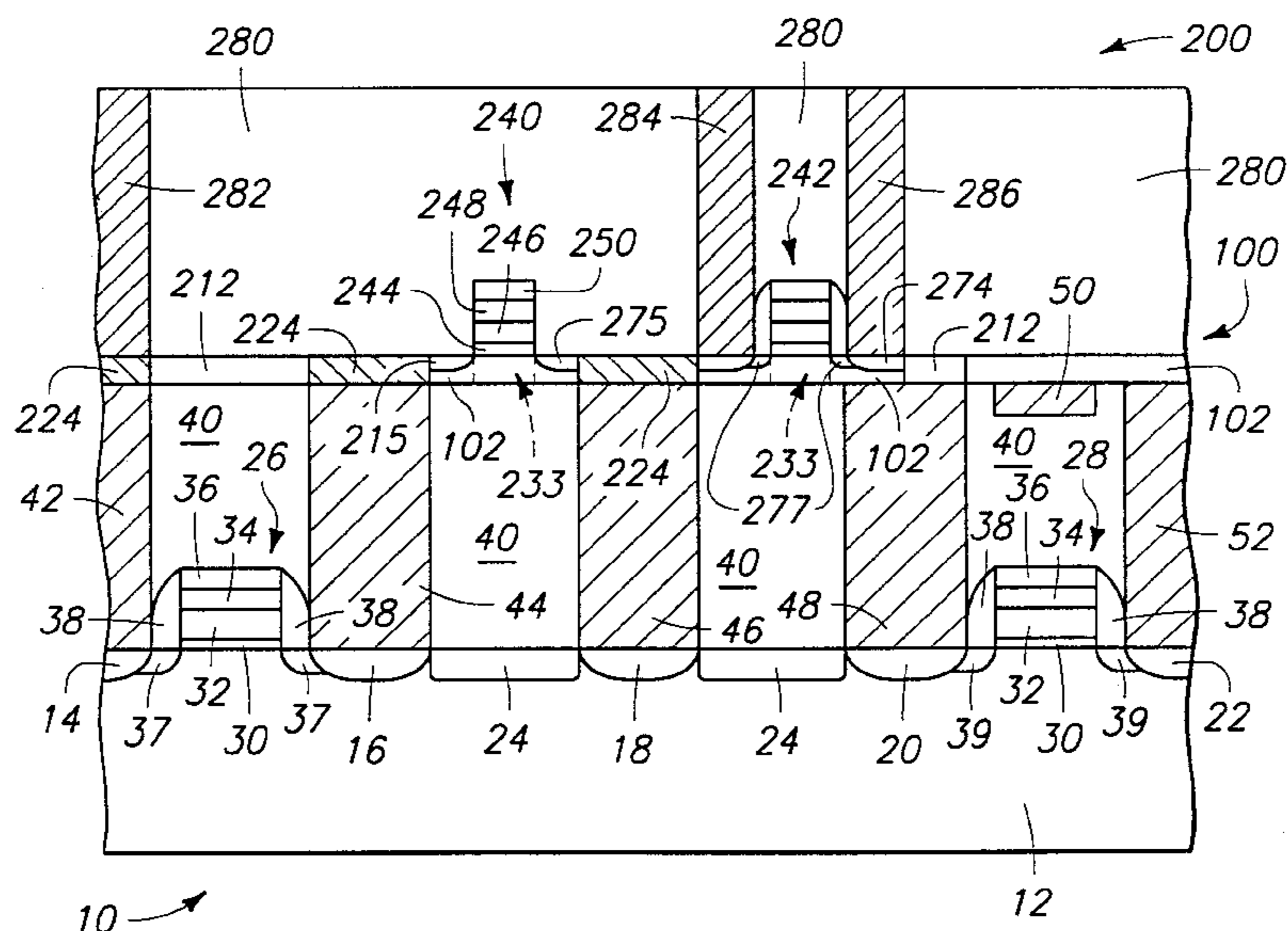

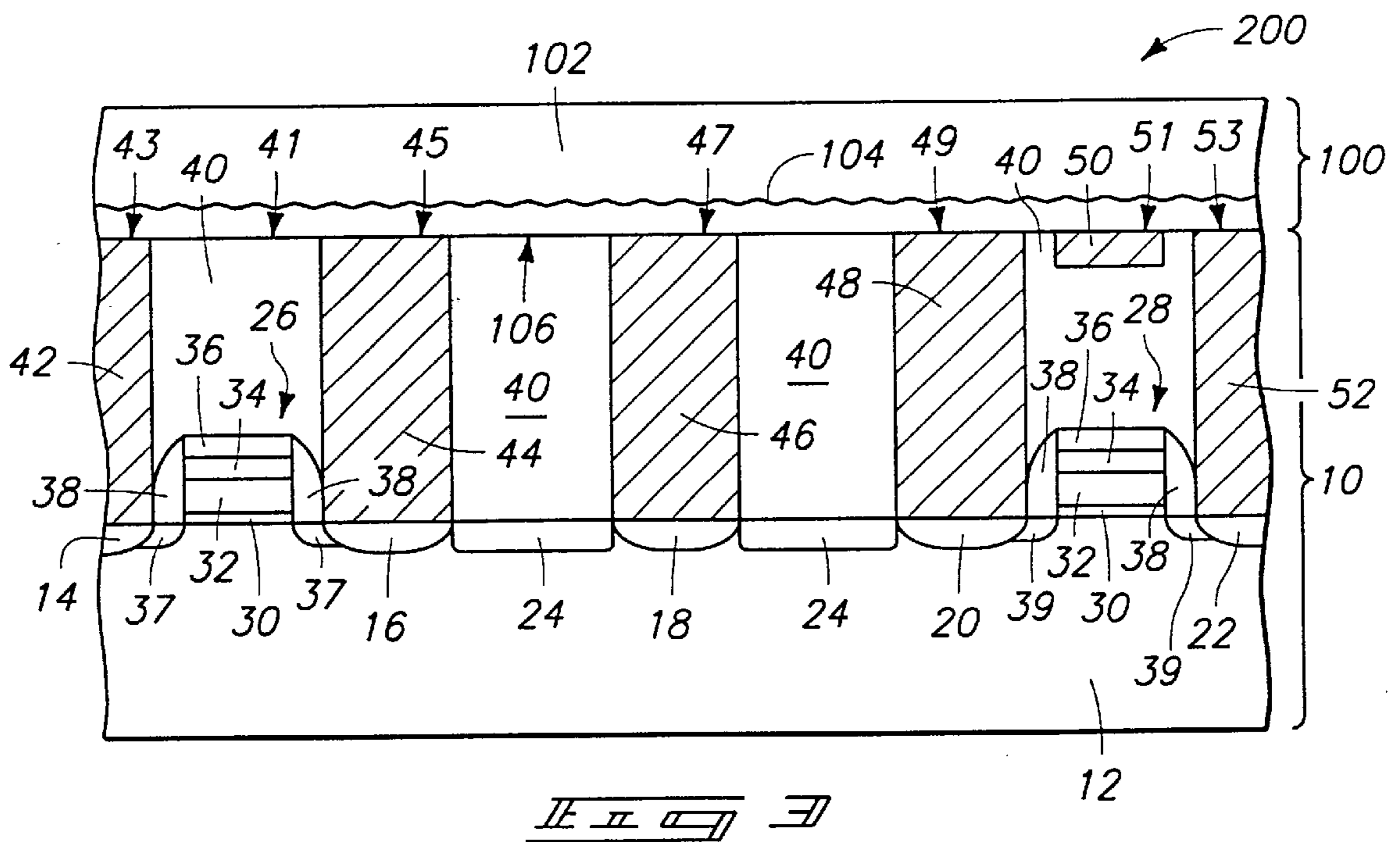
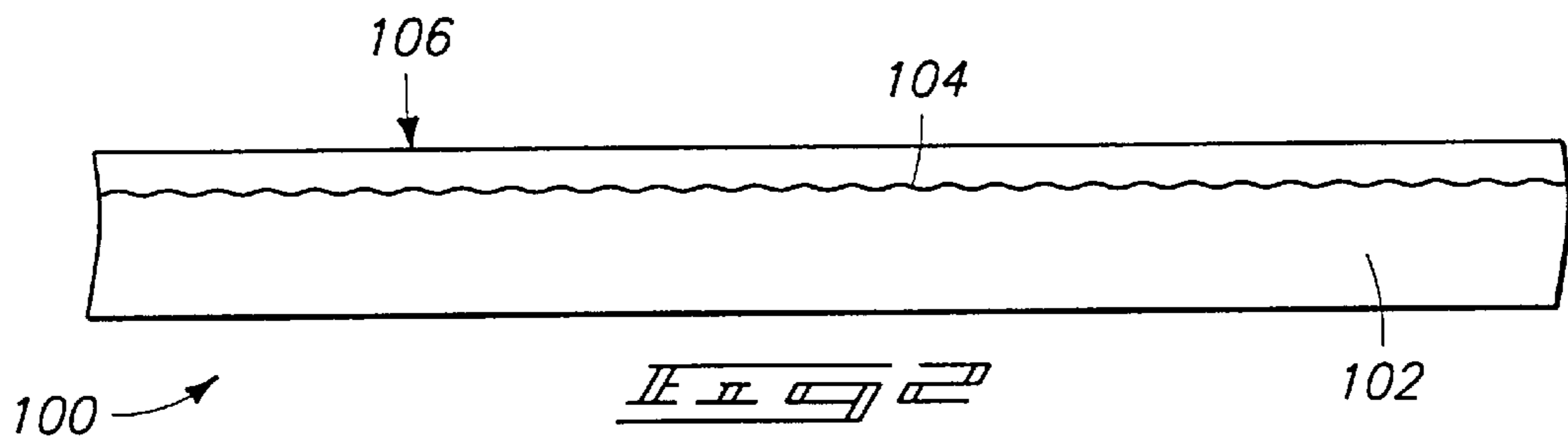
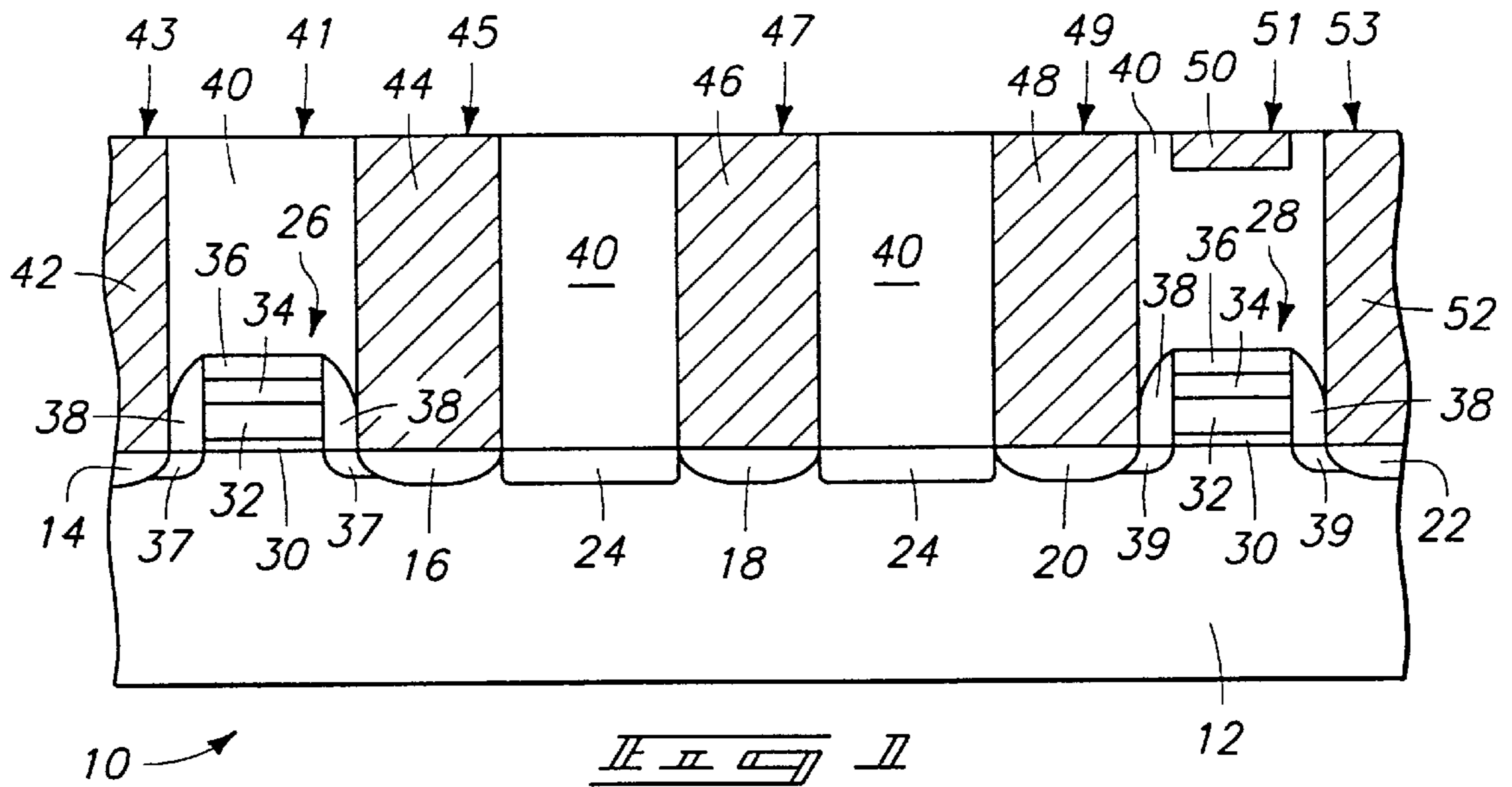

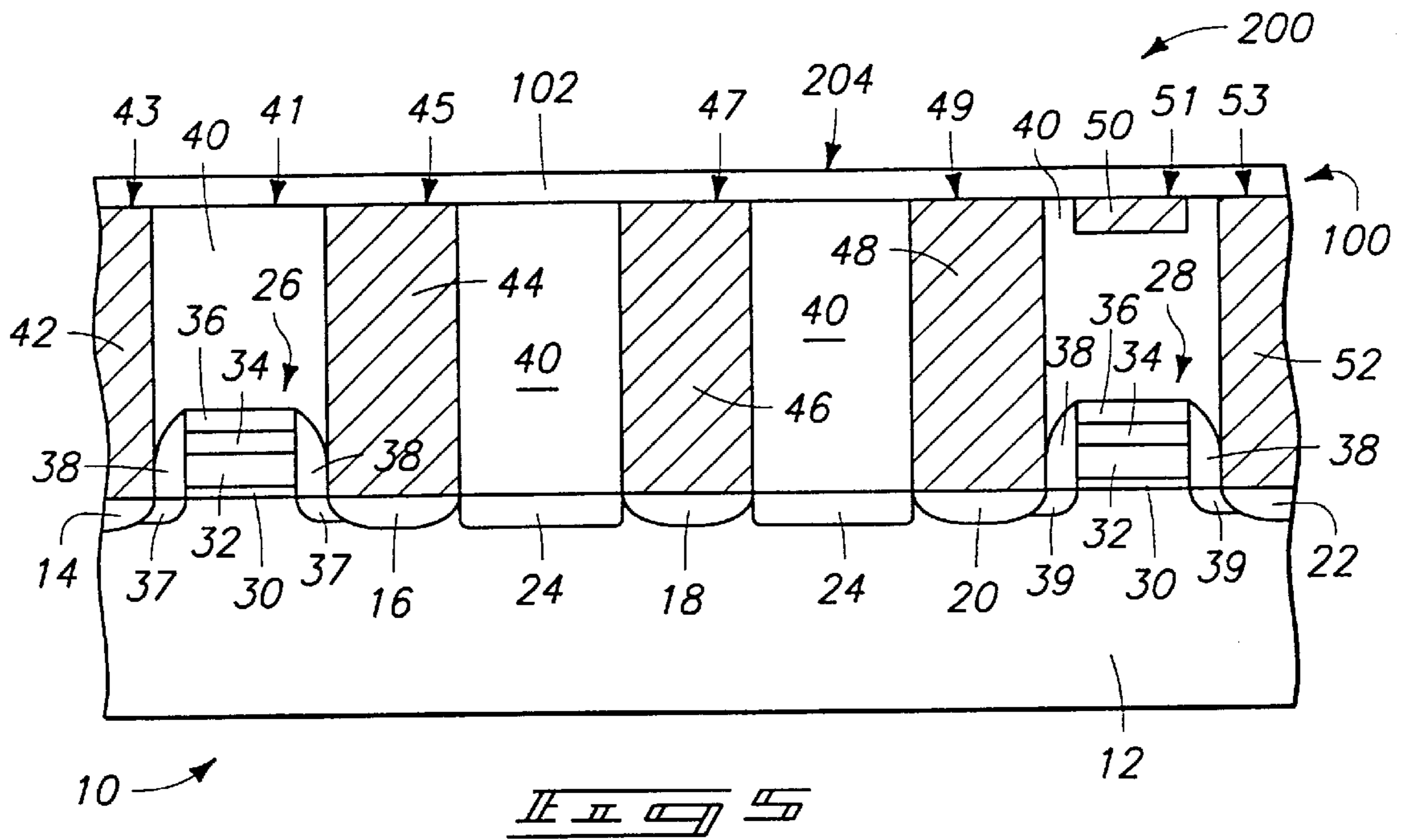
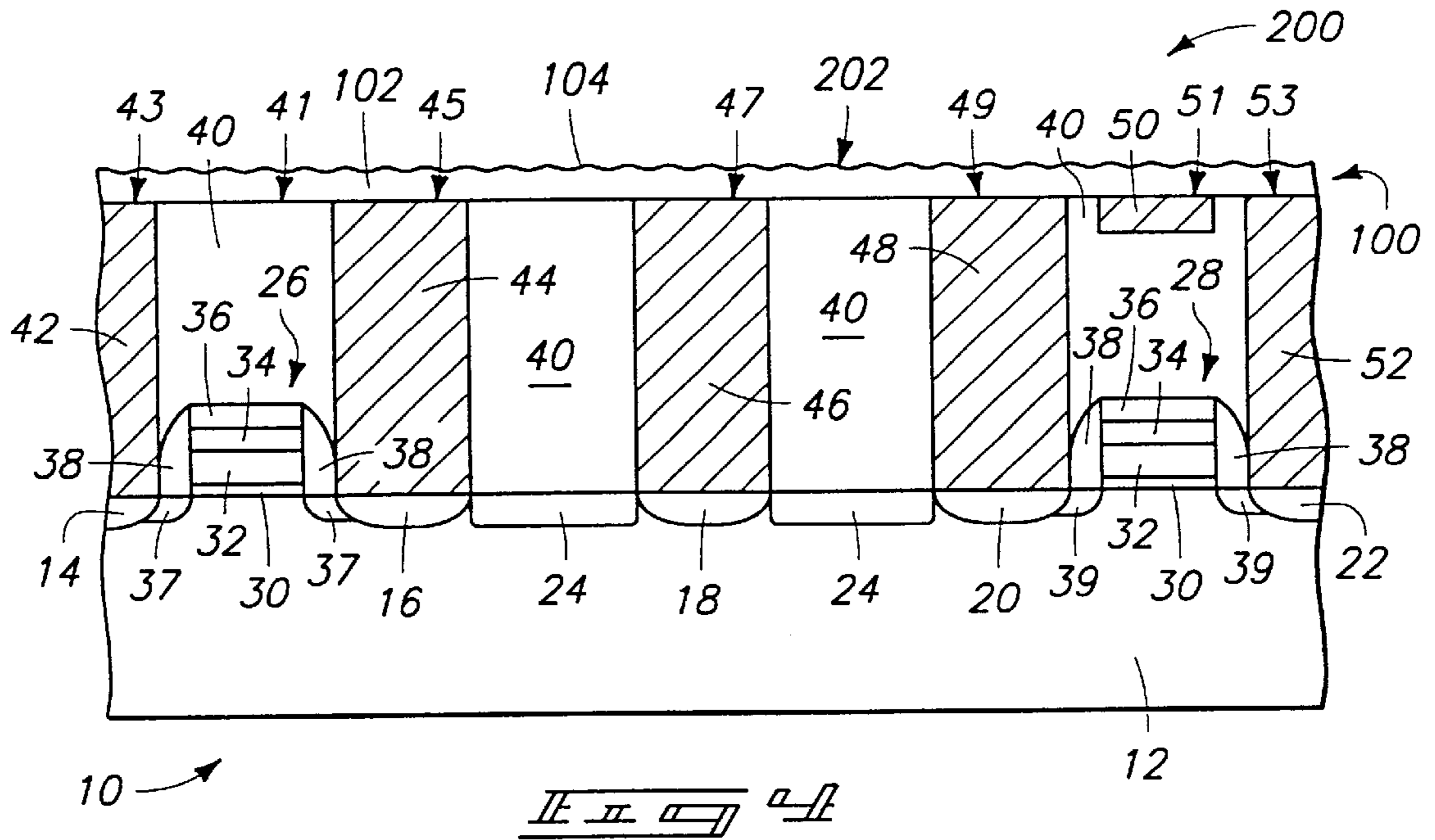

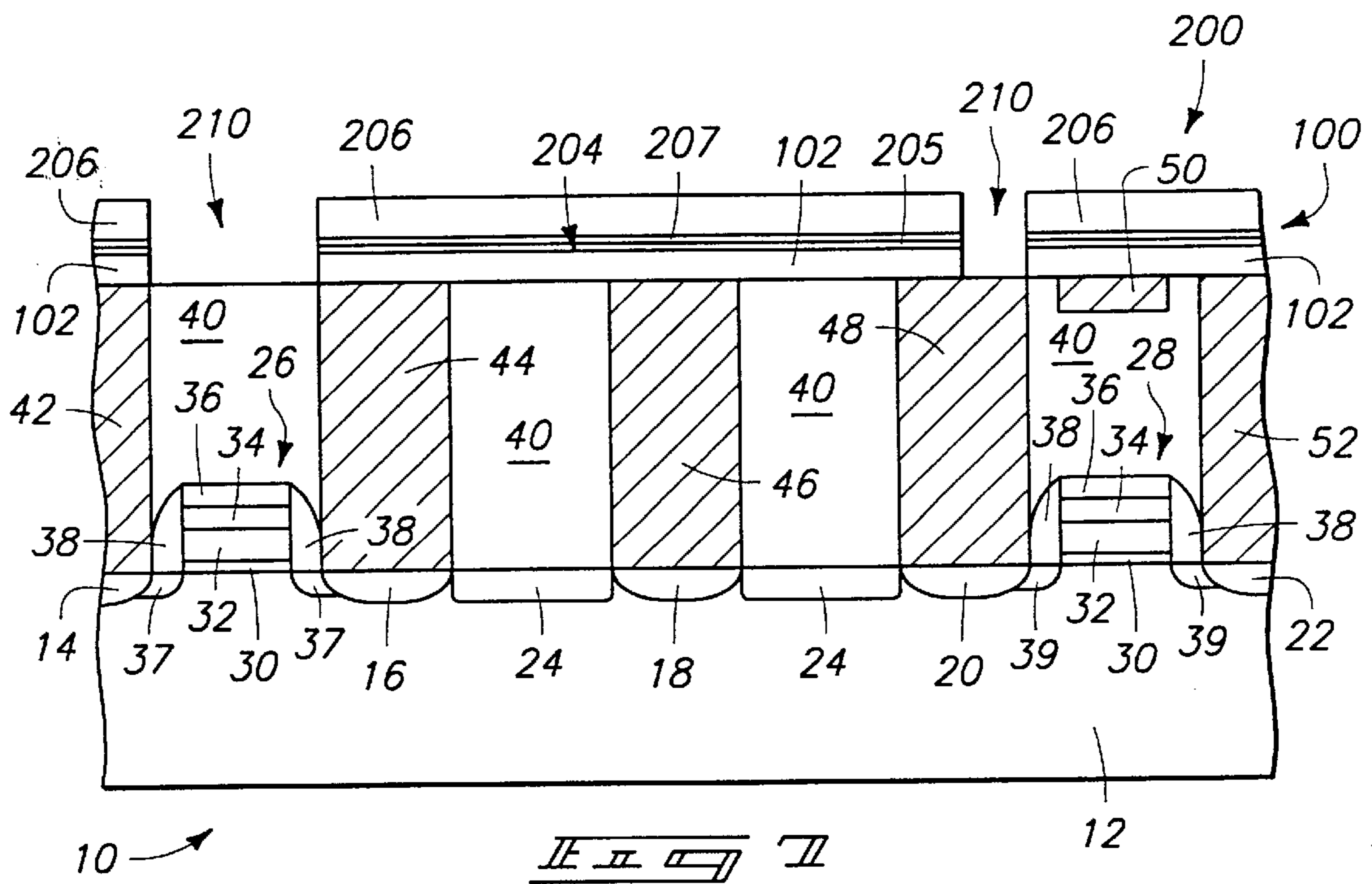
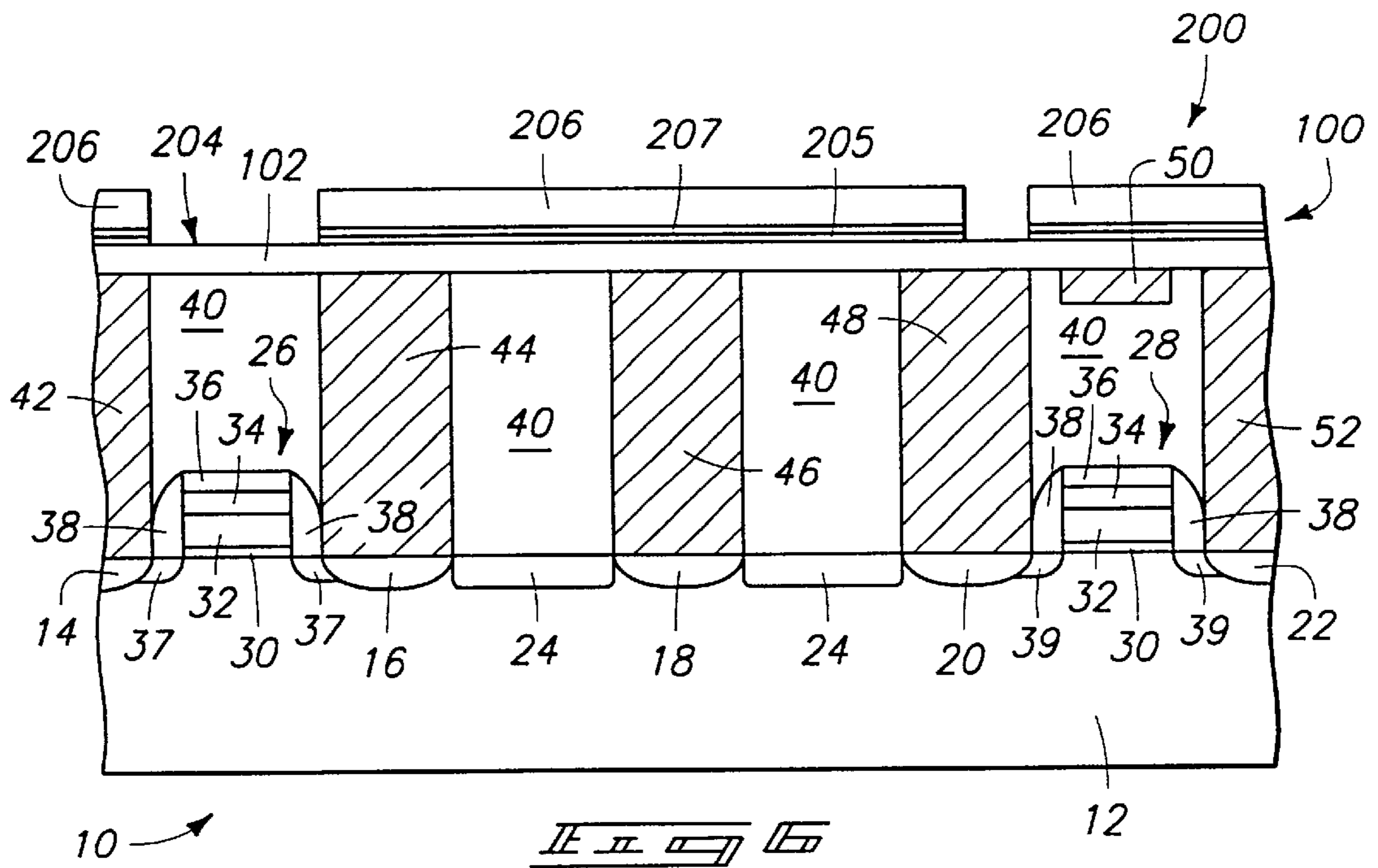

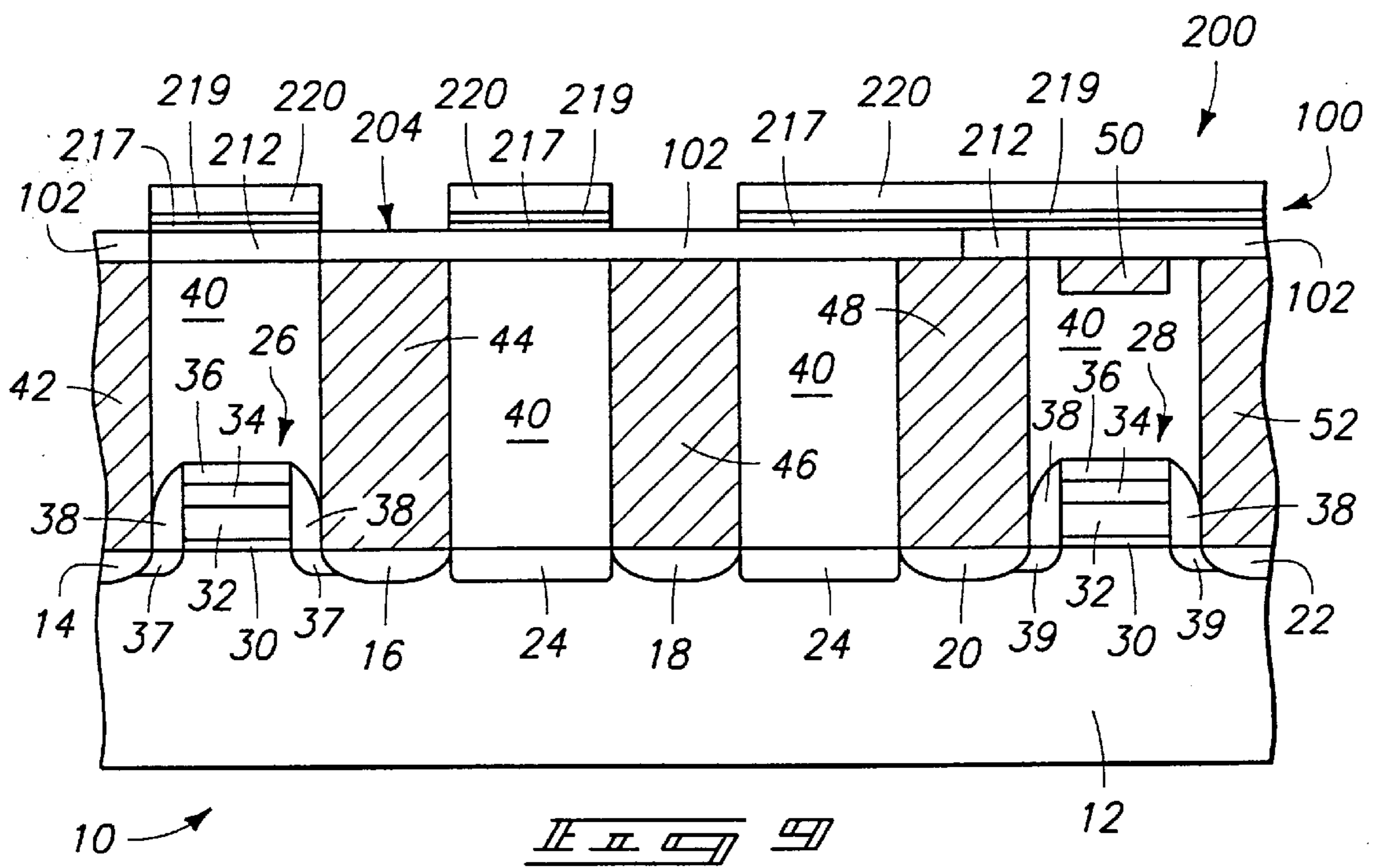
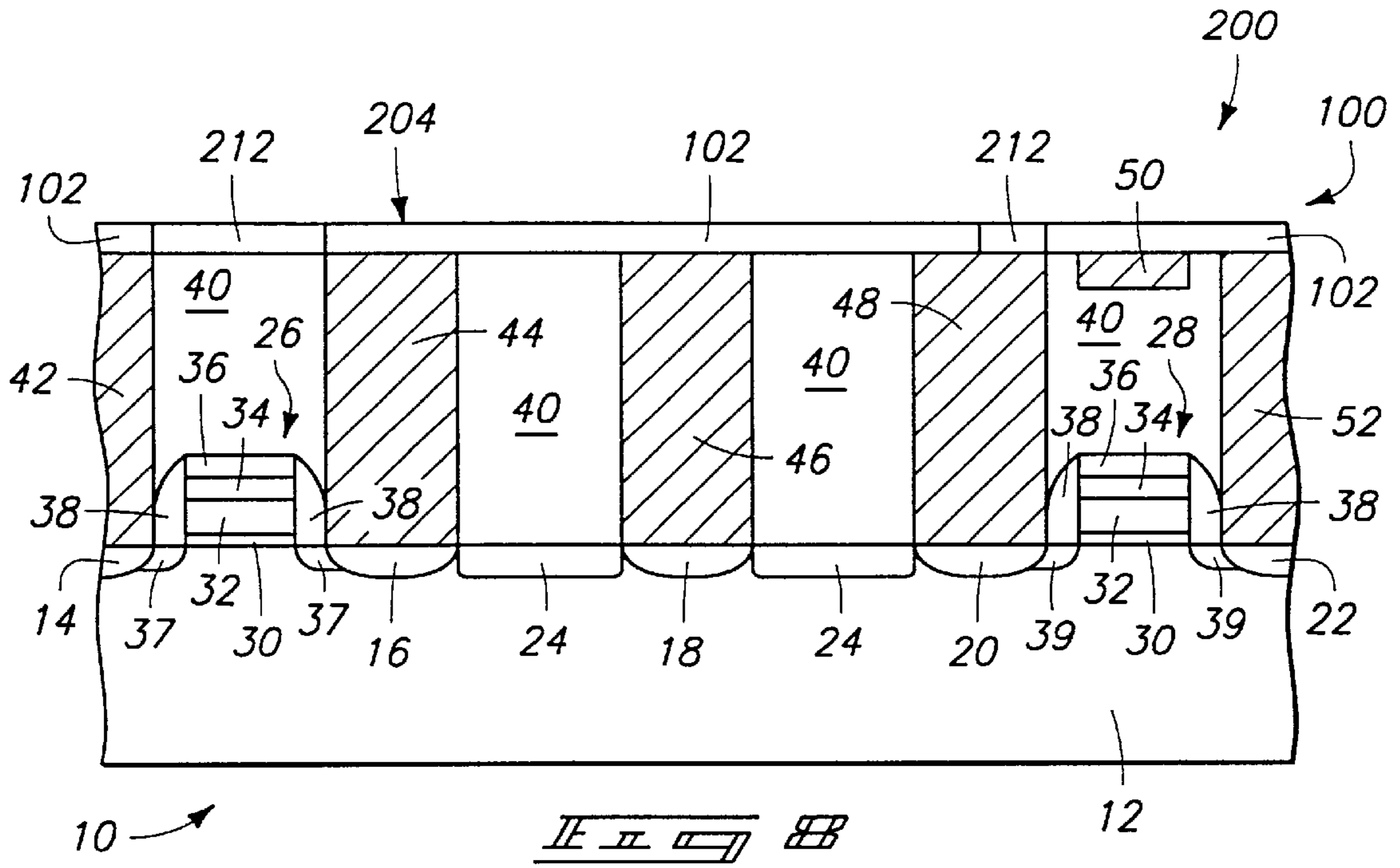

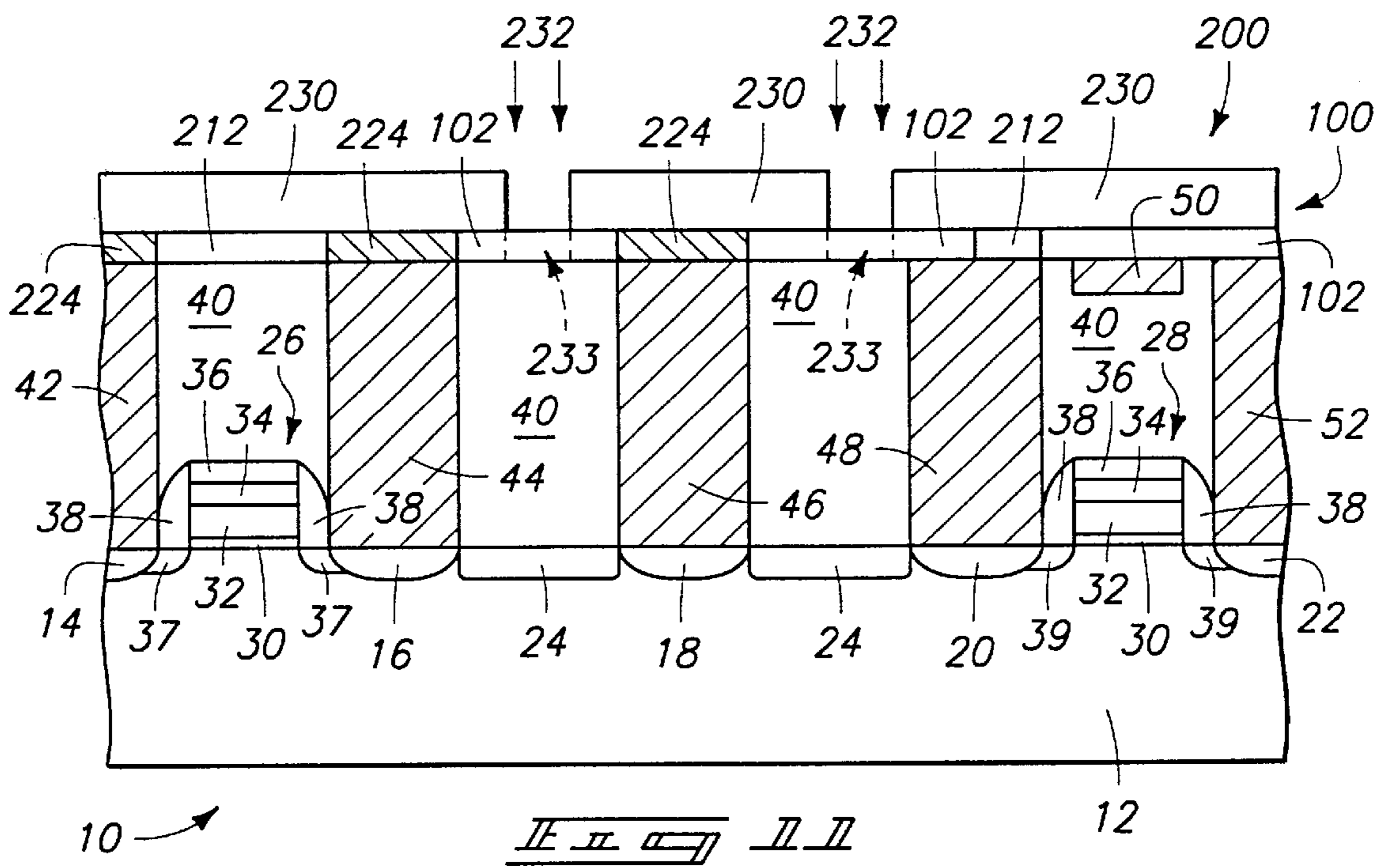
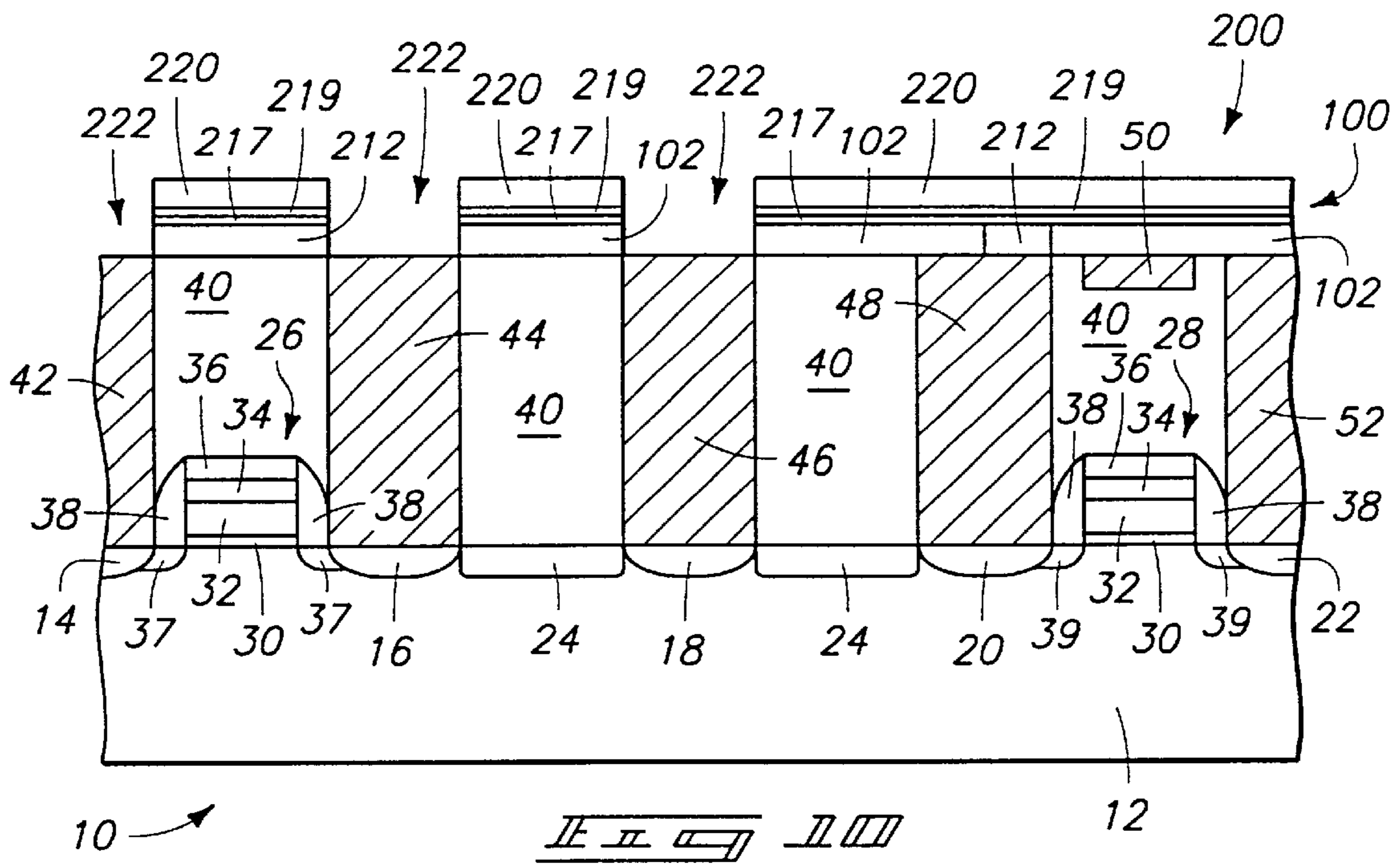

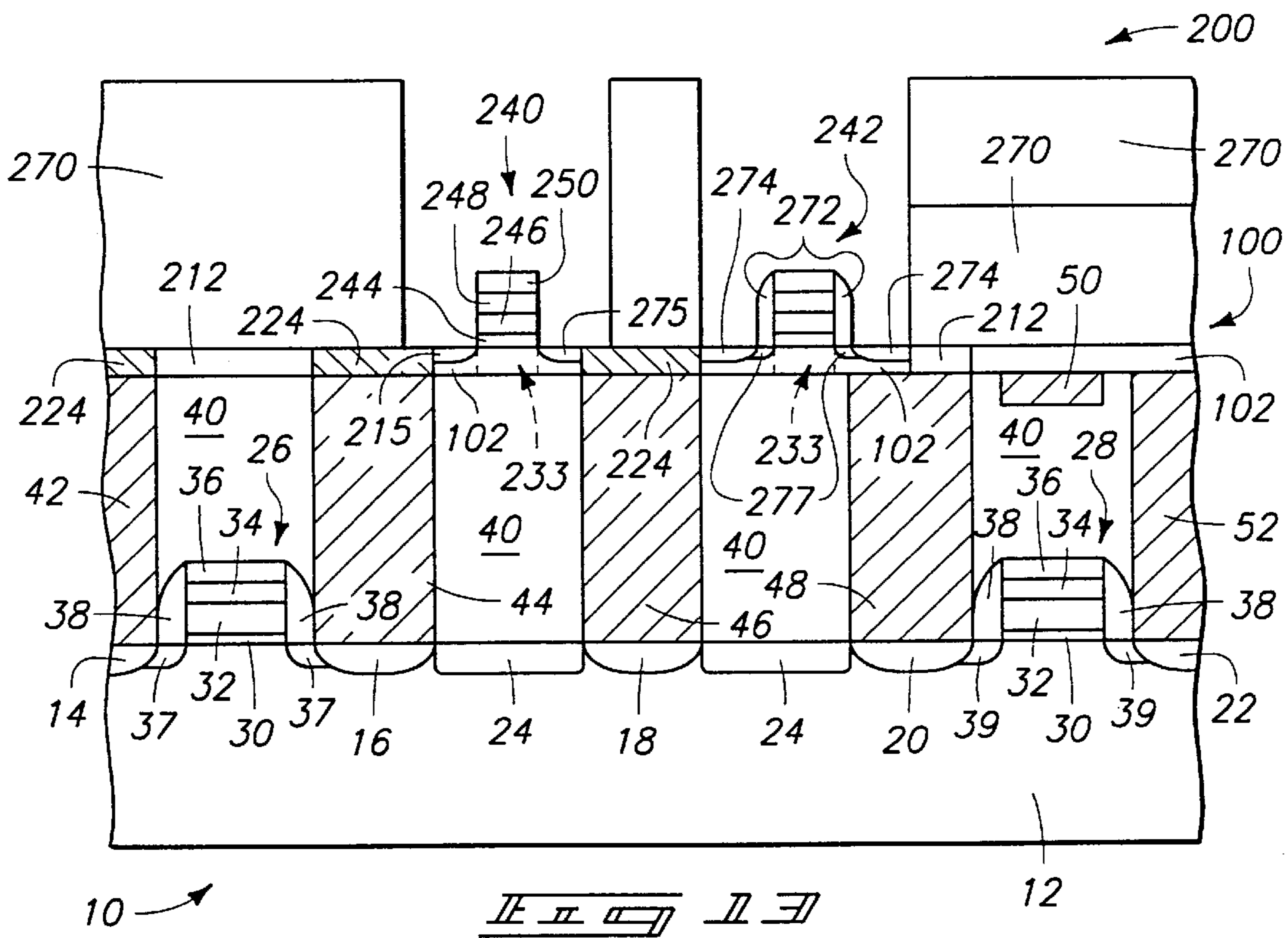
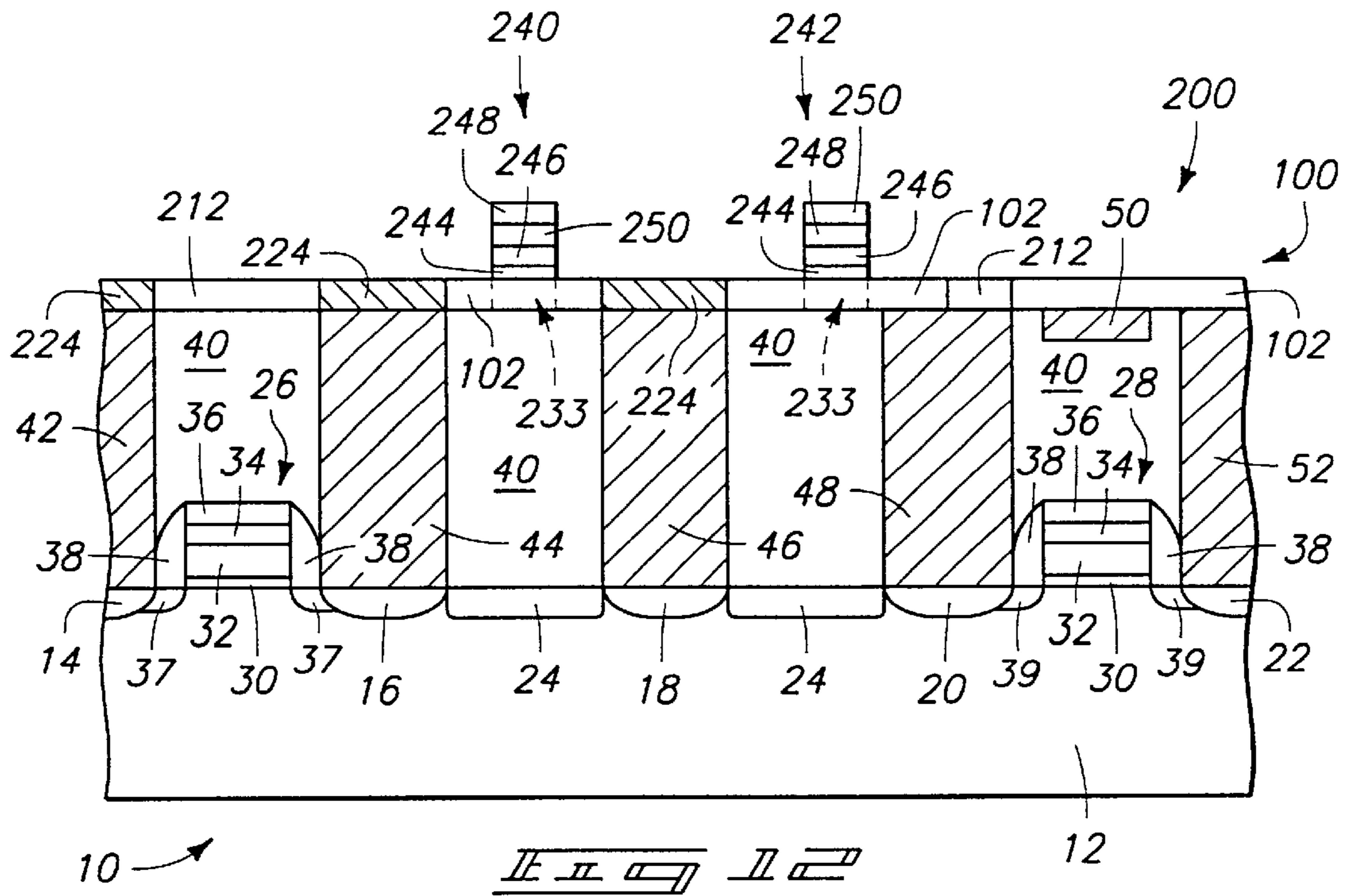

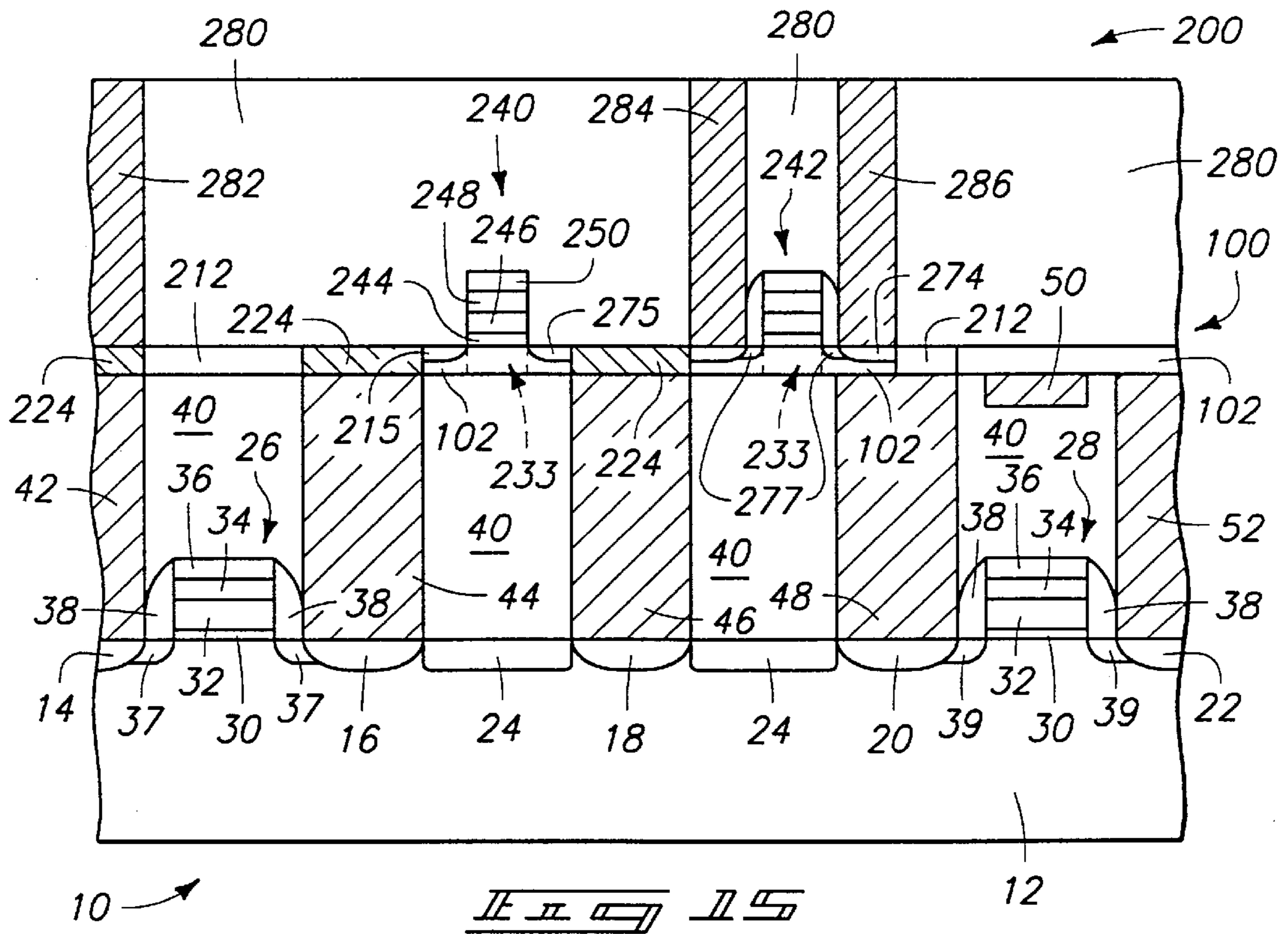
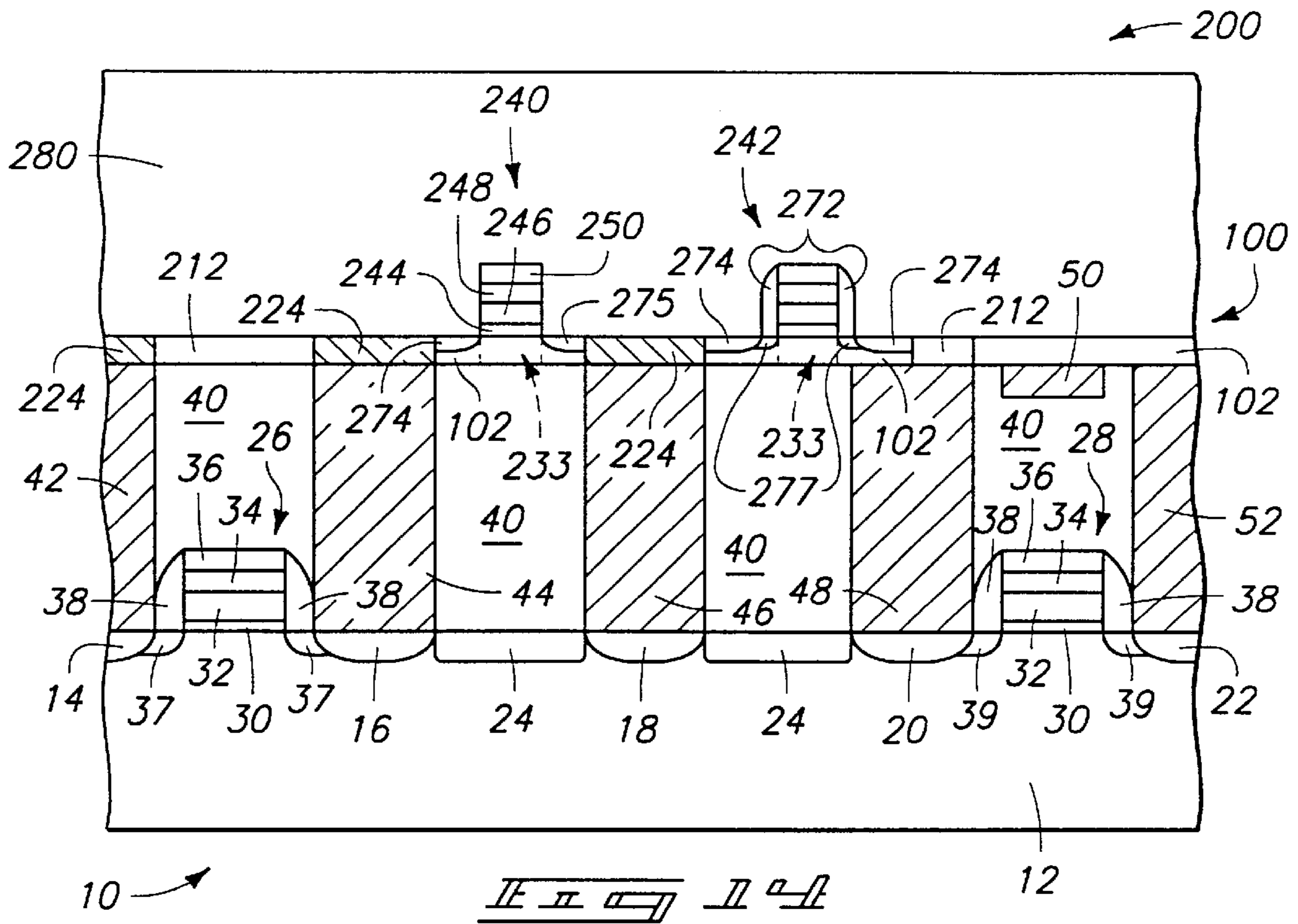

METHODS OF FORMING SEMICONDUCTOR CONSTRUCTIONS

RELATED PATENT DATA

This patent resulted from a divisional application of U.S. patent application Ser. No. 09/592,604, which was filed on Jun. 12, 2000.

TECHNICAL FIELD

The invention pertains to methods of forming semiconductor constructions in which a first semiconductor substrate is bonded to a second semiconductor substrate. The invention also pertains to semiconductor constructions comprising a first semiconductor substrate bonded to a second semiconductor substrate.

BACKGROUND OF THE INVENTION

Technologies referred to as “smart cut” and “wafer-bonding” have been utilized to bond monocrystalline silicon materials onto semiconductor substrates. Smart cut technology generally refers to a process in which a material is implanted into a silicon substrate to a particular depth and ultimately utilized to crack the substrate, and wafer bonding technology generally refers to a process in which a first semiconductive substrate is bonded to a second semiconductor substrate.

In particular applications of smart cut and wafer-bonding technology, hydrogen ions (which can be, for example, H⁺, H₂⁺, D⁺, D₂⁺) are implanted into a first monocrystalline silicon substrate to a desired depth. The first monocrystalline silicon substrate comprises a silicon dioxide surface, and is bonded to a second monocrystalline substrate through the silicon dioxide surface. Subsequently, the bonded first substrate is subjected to a thermal treatment which causes cleavage along the hydrogen ion implant region to split the first substrate at a pre-defined location. The portion of the first substrate remaining bonded to the second substrate can then be utilized as a silicon-on-insulator (SOI) substrate. An exemplary process is described in U.S. Pat. No. 5,953,622. The SOI substrate is subsequently annealed at a temperature of greater than or equal to 900° C. to strengthen chemical coupling within the second substrate.

The present invention encompasses new applications for smart cut and wafer-bonding technology, and new semiconductor structures which can be created utilizing such applications.

SUMMARY OF THE INVENTION

In one aspect, the invention includes a method of forming a semiconductor construction. A first substrate is provided which comprises silicon-containing structures separated from one another by an insulative material. The silicon-containing structures define an upper surface. A second semiconductor substrate is provided which comprises a monocrystalline material having a damage region therein. The second semiconductor substrate is bonded to the silicon-containing structures of the first substrate at the upper surface. The monocrystalline material is then cleaved along the damage region.

In another aspect, the invention encompasses another method of forming a semiconductor construction. A first substrate is provided which comprises silicon-containing structures separated from one another by an insulative material. The silicon-containing structures define an upper surface. A second semiconductor substrate is bonded to the

silicon-containing structures at the upper surface. The second semiconductor substrate comprises a mono-crystalline material. At least one doped silicon region is formed to extend through the monocrystalline material and to electrically contact at least one of the silicon-containing structures.

In another aspect, the invention encompasses a semiconductor construction comprising a first substrate having silicon-containing structures separated from one another by an insulative material, and a second substrate comprising a monocrystalline material. The silicon-containing structures of the first substrate define an upper surface, and the monocrystalline material of the second substrate is bonded over the silicon-containing structures at the upper surface.

BRIEF DESCRIPTION OF THE DRAWINGS

Preferred embodiments of the invention are described below with reference to the following accompanying drawings.

FIG. 1 is a diagrammatic, cross-sectional view of a first semiconductor substrate at a preliminary step of a method of the present invention.

FIG. 2 is a diagrammatic, cross-sectional, fragmentary view of a second semiconductor substrate at a preliminary step of a method of the present invention.

FIG. 3 is a diagrammatic, cross-sectional, fragmentary view of a semiconductive material comprising the first substrate of FIG. 1 and the second substrate of FIG. 2.

FIG. 4 is a diagrammatic, cross-sectional, fragmentary view of the FIG. 3 fragment shown at a processing step subsequent to that of FIG. 3.

FIG. 5 is a view of the FIG. 3 fragment shown at a processing step subsequent to that of FIG. 4.

FIG. 6 is a view of the FIG. 3 fragment shown at a processing step subsequent to that of FIG. 5.

FIG. 7 is a view of the FIG. 3 fragment shown at a processing step subsequent to that of FIG. 6.

FIG. 8 is a view of the FIG. 3 fragment shown at a processing step subsequent to that of FIG. 7.

FIG. 9 is a view of the FIG. 3 fragment shown at a processing step subsequent to that of FIG. 8.

FIG. 10 is a view of the FIG. 3 fragment shown at a processing step subsequent to that of FIG. 9.

FIG. 11 is a view of the FIG. 3 fragment shown at a processing step subsequent to that of FIG. 10.

FIG. 12 is a view of the FIG. 3 fragment shown at a processing step subsequent to that of FIG. 11.

FIG. 13 is a view of the FIG. 3 fragment shown at a processing step subsequent to that of FIG. 12.

FIG. 14 is a view of the FIG. 3 fragment shown at a processing step subsequent to that of FIG. 13.

FIG. 15 is a view of the FIG. 3 fragment shown at a processing step subsequent to that of FIG. 14.

DETAILED DESCRIPTION OF THE PREFERRED EMBODIMENTS

This disclosure of the invention is submitted in furtherance of the constitutional purposes of the U.S. Patent Laws “to promote the progress of science and useful arts” (Article 1, Section 8).

An exemplary method of the present invention is described with reference to FIGS. 1–15. Referring to FIG. 1, a first semiconductor substrate 10 is illustrated in fragmentary view. Substrate 10 comprises a monocrystalline silicon

wafer **12** having conductively-doped diffusion regions **14**, **16**, **18**, **20**, **22**, **37** and **39** therein. Diffusion regions **14**, **16**, **20**, **22**, **37** and **39** can comprise, for example, either n-type or p-type conductivity-enhancing dopants. Monocrystalline silicon wafer **12** can comprise a background doping with a p-type dopant. Although wafer **12** is described as comprising monocrystalline silicon, it is to be understood that wafer **12** can comprise other semiconductive materials, including, for example, germanium; or can comprise combinations of semiconductive materials, such as, for example, a combination of silicon and germanium. Wafer **12** can be referred to herein and in the claims that follow as a first base. To aid in interpretation of the claims that follow, the terms “semiconductive substrate” and “semiconductor substrate” are defined to mean any construction comprising semiconductive material, including, but not limited to, bulk semiconductive materials such as a semiconductive wafer (either alone or in assemblies comprising other materials thereon), and semiconductive material layers (either alone or in assemblies comprising other materials). The term “substrate” refers to any supporting structure, including, but not limited to, the semiconductive substrates described above.

Insulative isolation regions **24** are formed within substrate **12**. Isolation regions **24** can comprise, for example, silicon dioxide, and can be formed as shallow trench isolation regions.

Transistor gates **26** and **28** are formed over substrate **12** and comprise a gate oxide layer **30**, a polysilicon layer **32**, a silicide layer **34** and an insulative cap **36**. Sidewall spacers **38** are shown formed along gates **26** and **28**. Gate **26**, together with diffusion regions **14**, **16** and **37**, defines a first field effect transistor, and gate **28** together with diffusion regions **20**, **22** and **39** defines a second field effect transistor. In embodiments in which diffusion regions **14**, **16**, **20** and **22** are heavier doped with n-type dopant than p-type dopant, the first and second field effect transistors comprise NMOS transistors. Alternatively, if diffusion regions **14**, **16**, **20** and **22** are heavier doped with p-type dopant than n-type dopant, the first and second transistors can comprise PMOS transistors. Regions **37** and **39** can comprise lightly doped diffusion (Ldd) regions. It is noted that the above-described first and second field effect transistors are conventional transistor structures, and are provided as exemplary circuitry comprised by semiconductor substrate **10**. Other circuitry, including other forms of field effect transistors, can be comprised by semiconductor substrate **10** in alternative embodiments of the present invention.

An insulative material **40** is formed over wafer **12**, and over transistor gates **26** and **28**. Insulative material **40** can comprise, for example, silicon dioxide, borophosphosilicate glass (BPSG), or silicon nitride.

Silicon-containing structures **42**, **44**, **46**, **48**, **50** and **52** extend at least partially into insulative material **40**, with structures **42**, **44**, **46**, **48** and **52** extending entirely through material **40** to define plugs or pedestals. It is noted that the structure of FIG. **1** can be considered as comprising silicon-containing pedestals (defined by, for example, structures **44** and **46**) separated by insulative regions (defined by insulative material **40**), or alternately as comprising insulative pedestals (defined by insulative material **40**) separated by silicon-containing regions (defined by, for example, structures **44** and **46**).

The silicon-containing structures **42**, **44**, **46**, **48**, **50** and **52** can be formed by, for example, forming openings in insulative material **40**, and subsequently filling the openings with a silicon-containing material. It is to be understood that

the term silicon-containing structure encompasses, but is not limited to, structures which consist essentially of silicon, or consist of silicon. The silicon of structures **42**, **44**, **46**, **48**, **50** and **52** can comprise, for example, monocrystalline silicon, polycrystalline silicon, or amorphous silicon. In particular embodiments, the silicon of structures **42**, **44**, **46**, **48**, **50** and **52** can consist essentially of, for example, conductively-doped monocrystalline silicon, conductively-doped polycrystalline silicon, or conductively-doped amorphous silicon.

Structures **42**, **44**, **46**, **48** and **52** are preferably conductively doped, as such structures comprise conductive interconnections to diffusion regions associated with wafer **12**. In contrast, structure **50** is shown to not be connected with other circuit elements, and accordingly can remain undoped. Structure **50** will be described in the present disclosure as having no function as an electrical circuit element. Instead, structure **50** has a sole function of being provided for utilization in bonding a second semiconductor substrate through processing which is described below. Structure **50** has a different width than structures **42**, **44**, **46**, **48** and **52** to emphasize that structure **50** can be formed by a different pattern than the other structures.

Silicon-containing structures **42**, **44**, **46**, **48**, **50** and **52** have upper surfaces **43**, **45**, **47**, **49**, **51** and **53**, respectively. In the shown embodiment, such upper surfaces are planarized relative to one another, and at a common elevation above wafer **12**. Surfaces **43**, **45**, **47**, **49**, **51** and **53** thus define a common planarized upper surface which can be utilized in subsequent bonding (described below) to a second semiconductor substrate. The common upper surface of silicon-containing structures **42**, **44**, **46**, **48**, **50** and **52** can be formed by, for example, chemical-mechanical polishing. Preferably, such surface is substantially planar to the extent that the roughness of the common upper surface is defined by less than 5 Å root mean square (rms) variation. More preferably, the roughness is defined by less than 2 Å rms variation.

In the shown embodiment, insulative material **40** comprises an upper surface **41** that is planar and coextensive with the upper surfaces of silicon-containing structures **42**, **44**, **46**, **48**, **50** and **52**. The shown structure can be formed by, for example, chemical-mechanical planarization of insulative material **40** together with the silicon material of structures **42**, **44**, **46**, **48**, **50** and **52**. It is to be understood, however, that the invention encompasses other embodiments (not shown) wherein insulative material **40** comprises an upper surface which is downwardly recessed relative to the upper surfaces of silicon-containing structures **42**, **44**, **46**, **48**, **50** and **52**.

FIG. **2** shows a second semiconductor substrate **100** comprising a semiconductive material wafer **102**. Substrate **100** can be referred to as a second base. Semiconductive material wafer **102** can comprise, for example, monocrystalline silicon, and can be lightly doped with a background p-type dopant. Substrate **100** comprises a damage region **104** formed therein. Damage region **104** can be formed by, for example, implanting hydrogen ions into wafer **102**. Wafer **102** has an upper surface **106** which is preferably substantially planar, with the term “substantially planar” again referring to a surface defined by a roughness of less than 5 Å rms, and more preferably less than 2 Å rms.

Referring to FIG. **3**, second substrate **100** is inverted and bonded to first substrate **10** to form a structure **200**. More specifically, surface **106** of substrate **102** is bonded to surfaces **43**, **45**, **47**, **49**, **51** and **53** of silicon-containing

structures **42**, **44**, **46**, **48**, **50** and **52**. Surface **106** and surfaces **43**, **45**, **47**, **49**, **51** and **53** can be cleaned with, for example, hydrofluoric acid, immediately prior to the bonding to remove native oxide from over such surfaces. The bonding of substrate **100** to substrate **110** preferably comprises a temperature of less than or equal to about 700° C. and can comprise, for example, a temperature of about 700° C. for a time of at least about 15 minutes. A suitable time can be from about 15 minutes to about two hours. The bonding can occur under a nitrogen atmosphere at about atmospheric pressure, or alternatively can occur under a vacuum. A suitable vacuum is less than or equal to about 500 mTorr, and preferably less than or equal to about 10 mTorr. In a particular embodiment, the bonding can comprise a first temperature treatment of less than about 500° C., and a second temperature treatment of less than or equal to about 700° C. The treatment occurring at a temperature of less than about 500° C. is utilized as a preliminary bonding prior to cleaving of substrate **100** (described below with reference to FIG. 4), and the bonding at 700° C. occurs after such cleaving to enhance chemical coupling between substrate **102** and silicon-containing structures **42**, **44**, **46**, **48**, **50** and **52**.

In particular embodiments of the invention, the only temperatures utilized for bonding are less than or equal to 700° C., and monocrystalline wafer **12** is not exposed to temperatures exceeding 700° C. after the bonding. An advantage of utilizing temperatures less than or equal to about 700° C. for bonding and subsequent processing of structure **200** is that such can alleviate diffusion of dopants within semiconductor substrate **10** relative to diffusion which would occur at higher temperatures.

In embodiments in which diffusion of dopants is not considered problematic, temperatures above 700° C. can be utilized for bonding substrate **100** to substrate **10**. If insulative material **40** comprises silicon dioxide, such embodiments can comprise temperatures high enough to bond the silicon dioxide to monocrystalline silicon of base **102**, such as, for example, temperatures of 900° C. or greater. In such embodiments, base **102** will be bonded to upper surfaces **43**, **45**, **47**, **49**, **51** and **53** of silicon-containing structures **42**, **44**, **46**, **48**, **50** and **52**, and will also be bonded to upper surface **41** of insulative material **40**.

If bonding is conducted at temperatures wherein the bonding of monocrystalline base **102** is only to silicon-containing structures (e.g., **42**, **44**, **46**, **48**, **50** and **52**), it can be advantageous to add additional silicon-containing structures to substrate **10**. Structure **50** is an exemplary silicon-containing structure which has been added to substrate **10** solely for the purpose of enhancing bonding. In the shown embodiment, structure **50** extends only partially through insulative material **40**. In other embodiments, additional silicon-containing structures could be formed which extend entirely through insulative material **40**, and which, like structure **50**, have no function other than bonding of substrate **100** to substrate **10**.

Referring to FIG. 4, substrate **100** is cleaved along damage region **104**. In embodiments in which damage region **104** corresponds to a region wherein hydrogen ions were implanted, the cleavage can be accomplished by thermal processing. Suitable thermal processing can include, for example, exposure of damage region **104** to a temperature of greater than or equal to about 500° C.

The cleavage leaves a roughened upper surface **202** of structure **200**. Such surface can be planarized by, for example, chemical-mechanical planarization to form the

planar upper surface **204** shown in FIG. 5. In particular embodiments, the thickness of fragment **102** remaining after cleavage (FIG. 4) is about 0.5 microns, and the thickness after planarization (FIG. 5) is about 0.3 microns. The planarization shown in FIG. 5 can be referred to as “smoothing” of the roughened upper surface **202** of the FIG. 4 structure **200**.

FIGS. 6–15 illustrate formation of insulative and conductive elements over and on monocrystalline base **102** of structure **200**. Referring to FIG. 6, protective layers **205** and **207** (which can comprise, for example, silicon dioxide and silicon nitride, respectively) are formed, and a patterned masking layer **206** is formed over the protective layers. Patterned masking layer **206** can comprise, for example, photoresist, and can be patterned by photolithographic processing. Patterned masking layer **206** covers some portions of monocrystalline base **102**, while leaving other portions exposed. Referring to FIG. 7, the exposed portions of base **102** are removed to leave gaps **210** extending to upper surfaces of substrate **10**. In embodiments in which material **102** comprises monocrystalline silicon, such can be removed by, for example, an etch utilizing one or more of CF₄, O₂, and CF₃Cl.

Referring to FIG. 8, gaps **210** (FIG. 7) are filled with insulative material **212**, and masking layer **206** (FIG. 7) and protective layers **205** and **207** are removed. The removal of layers **205**, **206** and **207** can be accomplished by, for example, chemical-mechanical polishing. Insulative material **212** can comprise, for example, silicon dioxide or silicon nitride. The processing of FIGS. 6–8 can be referred to as a trench/refill process for forming insulative material within substrate **102**. In the shown embodiment, gaps **210** (FIG. 7) are formed to extend entirely through base **102**, and accordingly, insulative material **212** extends entirely through base **102**. In other embodiments (not shown) at least some of the gaps can be formed to extend only partially into base **102**, and accordingly at least some of insulative material **212** will extend only partially through base **102**. Insulative regions **212** can comprise isolation regions between devices formed on and within base **102**. Although the shown method of forming isolation regions is a trench/refill method, it is to be understood that other methods, such as, for example, local oxidation of silicon, could be utilized for forming isolation regions within a monocrystalline base **102**. The insulative regions are shown having a planarized upper surface, and such can be accomplished by, for example, chemical-mechanical polishing. It is noted that the described trench/refill can comprise forming the insulative material over the masking layer and within the gaps, and subsequent chemical-mechanical polishing to leave the insulative material within the gaps while removing the masking layer and insulative material thereover. Alternatively, the trench/refill can comprise removing the masking layer prior to forming the insulative material within the gaps.

Referring to FIG. 9, protective layers **217** and **219** (which can comprise, for example, silicon dioxide and silicon nitride, respectively) are formed. Subsequently, a patterned masking layer **220** is formed over the protective layers, over a surface **204** of base **102**, and over at least some of isolation regions **212**. Portions of base **102** are covered by masking layer **220**, while other portions are exposed. A pattern is transferred from masking layer **220** to underlying layers **217** and **219**, as shown.

Referring to FIG. 10, the exposed portions of base **102** are removed to form gaps **222** extending through material **102** and to an upper surface of substrate **10**. Gaps **222** can be formed utilizing processing similar to that described above with reference to FIG. 7 for forming gaps **210**.

Referring to FIG. 11, patterned masking layer 220 (FIG. 10) is removed and gaps 222 (FIG. 10) are filled with conductive material 224. Conductive material is typically formed within gaps 222 and over protective layers 217 and 219 (FIG. 10). Subsequently, the conductive material is removed from over the protective layers, and the protective layers are removed from over material 102. Layer 217 and 219 protect material 102 during removal of conductive material 224, as it can be difficult to selectively etch a preferred conductive material (doped silicon) relative to the monocrystalline material 102. A problem that can occur after forming conductive material 224 in gaps 222 is that leaky diodes can form at interfaces between material 224 and monocrystalline material 102. Such problem can be alleviated by lateral out-diffusion from material 224 into material 102 so that junctions are formed within material 102 rather than at interfaces of materials 102 and 224. The out-diffusion can be accomplished by, for example, a thermal treatment, and can laterally out-diffuse dopant to a distance of, for example, about 100 Å into material 102 from the interface of materials 102 and 224.

The conductively doped silicon of material 224 can be in the form of amorphous silicon, polycrystalline silicon, or monocrystalline silicon. Conductive material 224 can comprise, either alternatively or in addition to conductively doped silicon, other conductive materials such as, for example, metals or metal silicide. If the conductive material 224 comprises doped silicon, such can be either n-type doped silicon or p-type doped silicon. In particular embodiments it will be heavily n-type doped silicon (i.e., doped to a concentration greater than 1×10^{19} atoms/cm³ with an n-type dopant). Although conductive regions 224 are shown extending entirely through base 102, it is to be understood that regions 224 can extend either entirely into base 102 as shown, or only partially into base 102 in other embodiments (not shown).

A patterned masking layer 230 is formed over conductive material 224, insulative material 212, and some portions of base 102, while leaving other portions of base 102 exposed. Masking layer 230 can also be formed over channel regions, junction regions, and/or shallow trench isolation regions. A conductivity enhancing dopant 232 is implanted into the exposed portions of base 102 to form threshold voltage (V_t) implant regions 233 within base 102. The V_t implant regions can extend entirely through base 102, or only partially into base 102. The V_t implant regions can be formed with a blanket implant into an entirety of an upper surface of semiconductive material 102, and/or can be implanted through patterned photoresist for special adjustments. In exemplary applications, openings for V_t implants could extend over at least one channel and one or more of junctions and isolation regions.

Referring to FIG. 12, masking layer 230 (FIG. 11) is removed and transistor gates 240 and 242 are formed over the V_t implant regions 233. Transistor gates 240 and 242 comprise a gate oxide layer 244, a polysilicon layer 246, a metal silicide layer 248 and an insulative cap 250. Transistor gates 240 and 242 are conventional transistor gate structures, and provided as exemplary embodiments of transistor gates which can be formed. It is to be understood that other types of transistor gates, as well as other circuit devices, can be formed over base 102.

Referring to FIG. 13, a patterned masking layer is formed over some of base 102, while leaving transistors gate 240 and 242, and regions proximate transistor gates 240 and 242, exposed. Insulative material sidewall spacers 272 are shown formed along sidewalls of transistor gate 242, and not along

sidewalls of gate 240. Sidewall spacers 272 can be formed by conventional methods, including, by depositing and subsequently anisotropically etching an insulative material. the spacers can be selectively formed to be only along sidewalls of gate 242, and not along sidewalls of gate 240, by, for example, initially forming spacers along sidewalls of both of gates 240 and 242, and subsequently protecting the spacers along gate 242 while etching the spacers from along gate 240. Sidewall spacers 272 can comprise, for example, silicon dioxide or silicon nitride. In typical processing, a protective mask would be formed over transistor gate 240 while sidewall spacers 272 are formed alongside transistor gate 242. Alternatively, spacers could be formed alongside sidewalls of gate 240, as well as alongside the sidewalls of gate 242.

Source/drain regions 274 and 275 are implanted proximate gates 240 and 242, and Ldd regions 277 are implanted between source/drain regions 274 and gate 242. Ldd regions 277 can be implanted prior to formation of spacers 272, or with an angled implant after formation of spacers 272. Gate 242 and source/drain regions 274 define a field effect transistor, while gate 240 and source/drain regions 275 define another field effect transistor. In the shown embodiment, source/drain regions 274 are implanted only partially into base 102. It is to be understood, however, that the invention encompasses other embodiments wherein source/drain regions are implanted deep enough into base 102 to extend entirely through the base.

Source/drain regions 275 are, in addition to being source/drain regions, conductive interconnections between circuitry above base 102 and circuitry below base 102. Specifically, source/drain regions 275 interconnect with regions 224, which in turn interconnect to circuitry beneath base 102. The regions 224 interconnect with source/drain regions 275 can be considered extensions of the source/drain regions. Source drain regions 275 allow some misalignment of patterning to form transistor gate 240, as the regions 275 will extend between gate 240 and regions 224 regardless of whether gate 240 is precisely centered between adjacent regions 224 or not.

Referring to FIG. 14, masking layer 270 (FIG. 13) is removed, and an insulative material 280 is formed over substrate 100 and transistor gates 240 and 242. Insulative material 280 can comprise, for example, BPSG.

Referring to FIG. 15, openings are etched into insulative material 280 and conductive structures 282, 284 and 286 are formed within the openings. Conductive structures 282, 284 and 286 can comprise, for example, one or more of conductively-doped amorphous silicon, polycrystalline silicon, or monocrystalline silicon. Structures 282, 284 and 286 can thus comprise silicon-containing structures. In subsequent processing (not shown) another semiconductor substrate can be bonded to silicon-containing structures 282, 284 and 286 and processing analogous to that of FIGS. 6–15 repeated to form circuitry on the next semiconductor substrate. Accordingly, a stack of semiconductor substrates and circuitry can be formed.

In other embodiments, structures 282, 284 and 286 can comprise other conductive materials besides silicon, such as, for example, metals and/or metal silicides.

In particular processing, at least one of the transistors comprising gates 26 and 28 between semiconductive material bases 12 and 102 is of a different type than at least one of the transistors comprising gates that are on semiconductive material base 102. For instance, at least one of the transistors comprising gates 26 and 28 can be a PMOS

transistor, and at least one of the transistors comprising gates **240** and **242** can be an NMOS transistor. In other embodiments, one type of transistor will be formed over base **102** which is not formed between bases **102** and **12**. For instance, only n-type transistors can be formed between bases **102** and **12**, and both n-type and p-type transistors can be formed over base **102**. In still other embodiments, one type of transistor will be formed over between bases **12** and **102** which is not formed over base **102**. For instance, only n-type transistors can be formed over base **102**, and both n-type and p-type transistors can be formed between bases **12** and **102**.

Processing of the present invention can be utilized with either or both of logic and memory device constructions. In particular embodiments the processing can be utilized to form DRAM constructions having increased device density and increased data retention relative to conventional DRAM constructions.

In compliance with the statute, the invention has been described in language more or less specific as to structural and methodical features. It is to be understood, however, that the invention is not limited to the specific features shown and described, since the means herein disclosed comprise preferred forms of putting the invention into effect. The invention is, therefore, claimed in any of its forms or modifications within the proper scope of the appended claims appropriately interpreted in accordance with the doctrine of equivalents.

What is claimed is:

1. A method of forming a semiconductor construction, comprising:

forming a first semiconductor substrate comprising a first monocrystalline base and having a first transistor supported on the first monocrystalline base; the first transistor having source/drain regions associated therewith; the first substrate also having an insulative material formed over the base and silicon-containing plugs extending through the insulative material and to the source/drain regions; the silicon-containing plugs being separated from one another by the insulative material and defining a planarized upper surface above the first monocrystalline base;

providing a second semiconductor substrate comprising a second monocrystalline base and bonding the second semiconductor substrate to the silicon-containing plugs at the planarized upper surface above the first monocrystalline base; and

forming a second transistor supported over the second substrate.

2. The method of claim **1** wherein one of the first and second transistors is a PMOS transistor and wherein the other of the first and second transistors is an NMOS transistor.

3. The method of claim **1** wherein the second transistor comprises source/drain regions which extend entirely through the second monocrystalline base.

4. The method of claim **1** wherein the second transistor comprises source/drain regions which extend only partially through the second monocrystalline base.

5. A method of forming a semiconductor construction, comprising:

forming a first substrate comprising silicon-containing structures separated from one another by an insulative material; the silicon-containing structures defining an upper surface;

bonding a second semiconductor substrate to the silicon-containing structures at the upper surface; the second semiconductor substrate comprising a monocrystalline material which is bonded to the silicon-containing structures; and

forming at least one doped silicon region extending through the monocrystalline material and electrically contacting at least one of the silicon-containing structures.

6. The method of claim **5** wherein the forming the at least one doped silicon region comprises implanting dopant into the monocrystalline material.

7. The method of claim **5** further comprising forming at least one insulative region extending at least partially into the monocrystalline material.

8. The method of claim **5** further comprising forming at least one insulative region extending through the monocrystalline material.

9. The method of claim **8** wherein the forming the at least one insulative region comprises:

forming an opening through the monocrystalline material; and

filling the opening with an insulative material.

10. The method of claim **5** wherein the forming the at least one doped silicon region comprises:

forming an opening through the monocrystalline material; and

filling the opening with a doped silicon material.

11. The method of claim **10** wherein the doped silicon material comprises doped amorphous silicon.

12. The method of claim **10** wherein the doped silicon material comprises doped polycrystalline silicon.

13. The method of claim **5** further comprising forming at least one second doped silicon region within the second monocrystalline base and which does not extend entirely through the second monocrystalline base.

14. The method of claim **13** wherein the forming the at least one doped silicon region comprises:

forming an opening through the monocrystalline material; and

filling the opening with a doped silicon material.

15. The method of claim **14** wherein the doped silicon material comprises doped amorphous silicon.

16. The method of claim **14** wherein the doped silicon material comprises doped polycrystalline silicon.