



US006599089B2

(12) **United States Patent**  
**Aksit et al.**

(10) **Patent No.:** **US 6,599,089 B2**  
(45) **Date of Patent:** **Jul. 29, 2003**

(54) **SUPPLEMENTAL SEAL FOR THE CHORDAL HINGE SEAL IN A GAS TURBINE**

(75) Inventors: **Mahmut Faruk Aksit**, Istanbul (TR);  
**Ahmad Safi**, Troy, NY (US);  
**Abdul-Azeez Mohammed-Fakir**,  
Schenectady, NY (US); **Iain Robertson**  
**Kellock**, Simpsonville, SC (US)

(73) Assignee: **General Electric Company**,  
Schenectady, NY (US)

(\*) Notice: Subject to any disclaimer, the term of this patent is extended or adjusted under 35 U.S.C. 154(b) by 0 days.

(21) Appl. No.: **10/029,227**

(22) Filed: **Dec. 28, 2001**

(65) **Prior Publication Data**

US 2003/0123982 A1 Jul. 3, 2003

(51) **Int. Cl.<sup>7</sup>** ..... **F01D 9/04**

(52) **U.S. Cl.** ..... **415/191; 415/209.2**

(58) **Field of Search** ..... 415/191, 209.2,  
415/209.3, 231; 277/628, 630, 637, 641,  
644, 647

(56) **References Cited**

U.S. PATENT DOCUMENTS

4,184,689 A \* 1/1980 Brodell et al. .... 415/134

4,645,217 A	2/1987	Honeycutt, Jr. et al.
4,863,343 A	9/1989	Smed
5,149,250 A *	9/1992	Plemmons et al. .... 415/209.3
5,372,476 A *	12/1994	Hemmelgarn et al. .... 415/135
5,474,306 A	12/1995	Bagepalli et al.
5,509,669 A	4/1996	Wolfe et al.
5,586,773 A	12/1996	Bagepalli et al.
5,657,998 A	8/1997	Dinc et al.
5,915,697 A	6/1999	Bagepalli et al.
5,934,687 A	8/1999	Bagepalli et al.
6,162,014 A	12/2000	Bagepalli et al.

\* cited by examiner

*Primary Examiner*—Ninh H. Nguyen

(74) *Attorney, Agent, or Firm*—Nixon & Vanderhye

(57) **ABSTRACT**

In a gas turbine having a chordal hinge seal between an inner rail of each nozzle segment and an annular axially facing sealing surface of a nozzle support ring, a supplemental seal is disposed between the support ring and inner rail of the nozzle segment on a high pressure side of the chordal hinge seal. The supplemental seal includes a pair of sheet metal shims overlaid by a woven metallic cloth supported by a bracket secured to a back side surface of the inner rail. The radially inner end of the cloth seal bears against the annular sealing surface of the nozzle support ring. The shims of the legs of the supplemental seal are slit along their distal margin and staggered in a chord-wise direction relative to one another to provide flexibility and effective sealing engagement with the nozzle support ring.

**18 Claims, 8 Drawing Sheets**

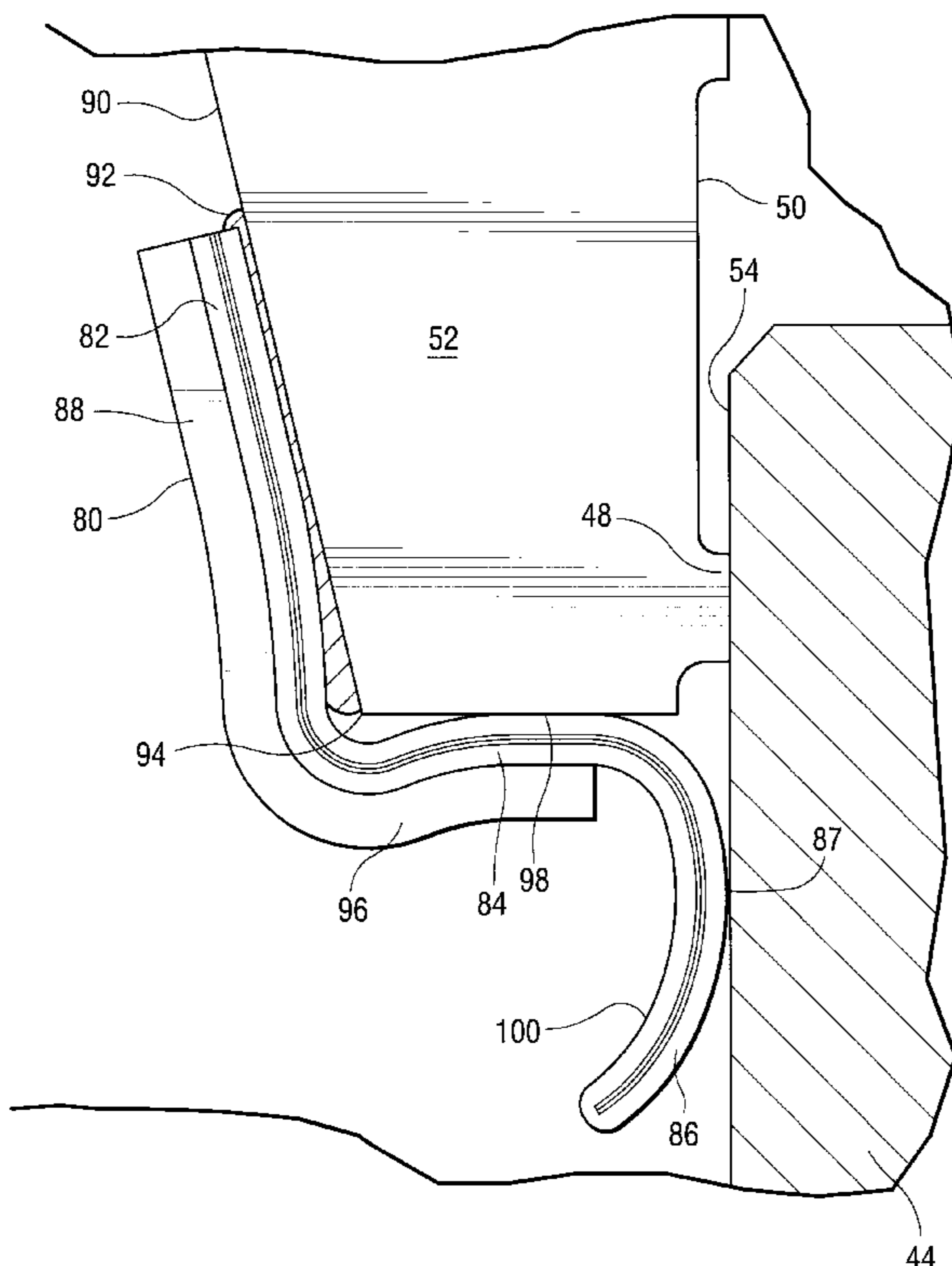

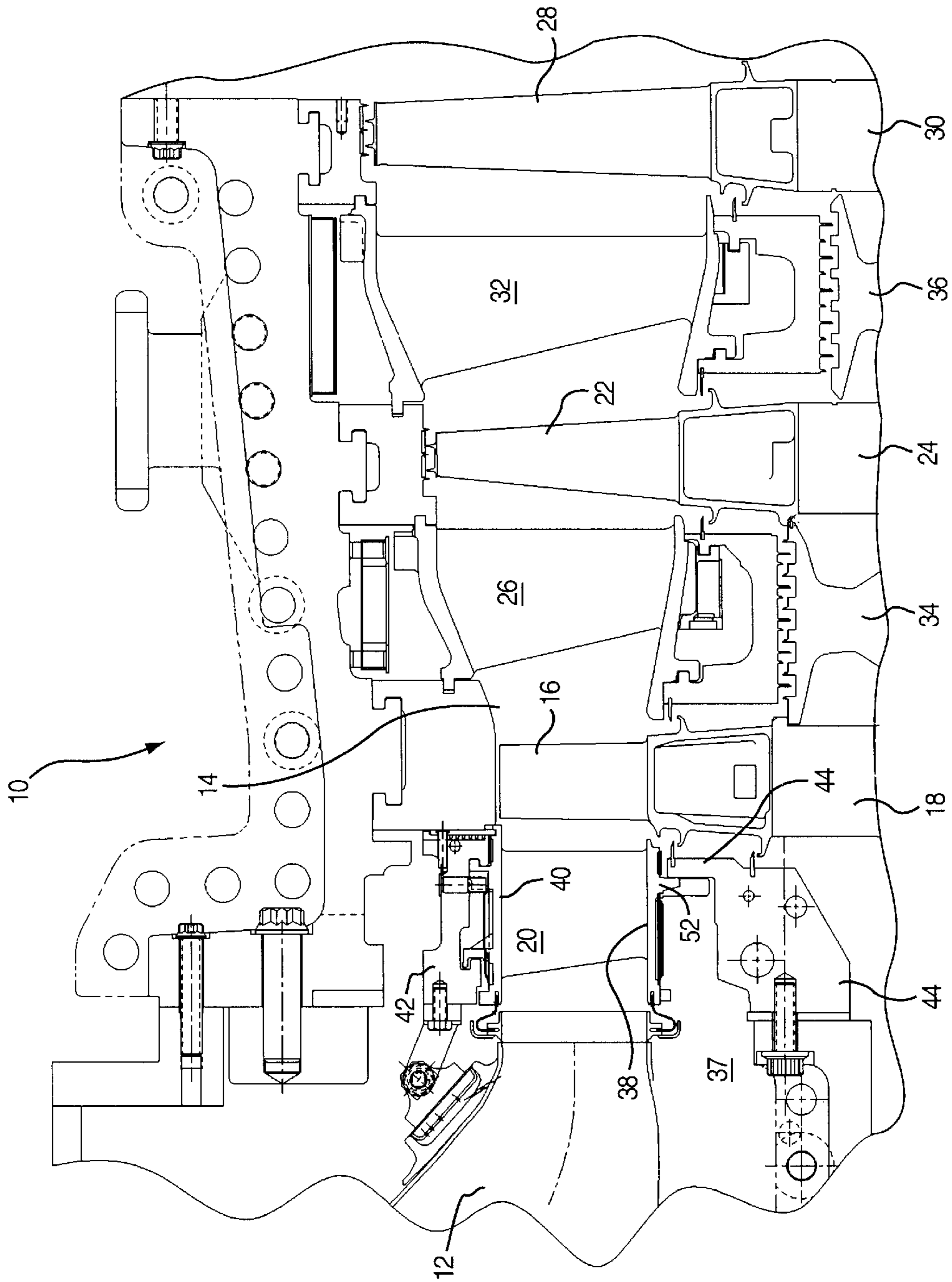

Fig. 1  
(Prior Art)

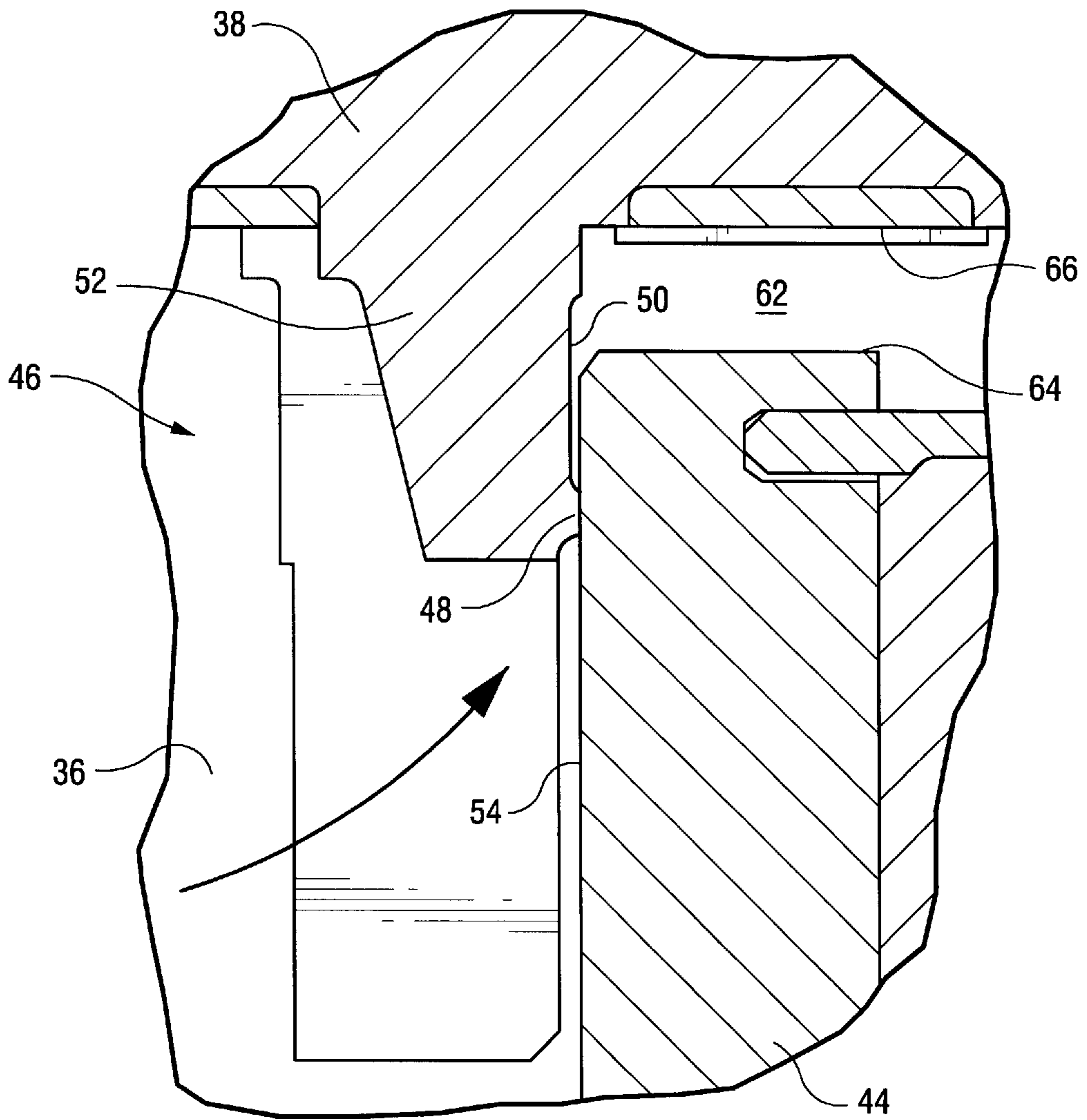

Fig. 2  
(Prior Art)

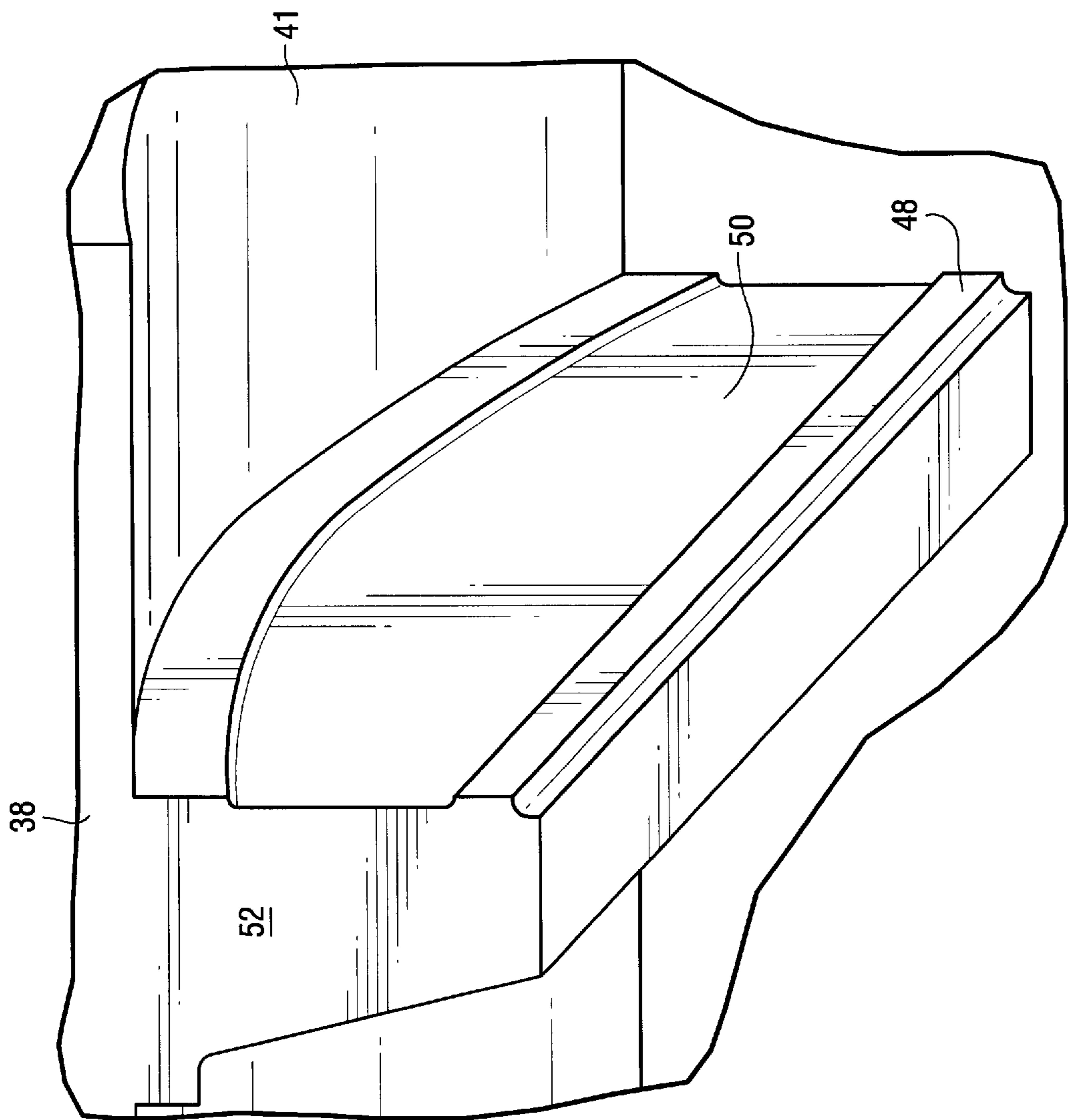

Fig. 3  
(Prior Art)

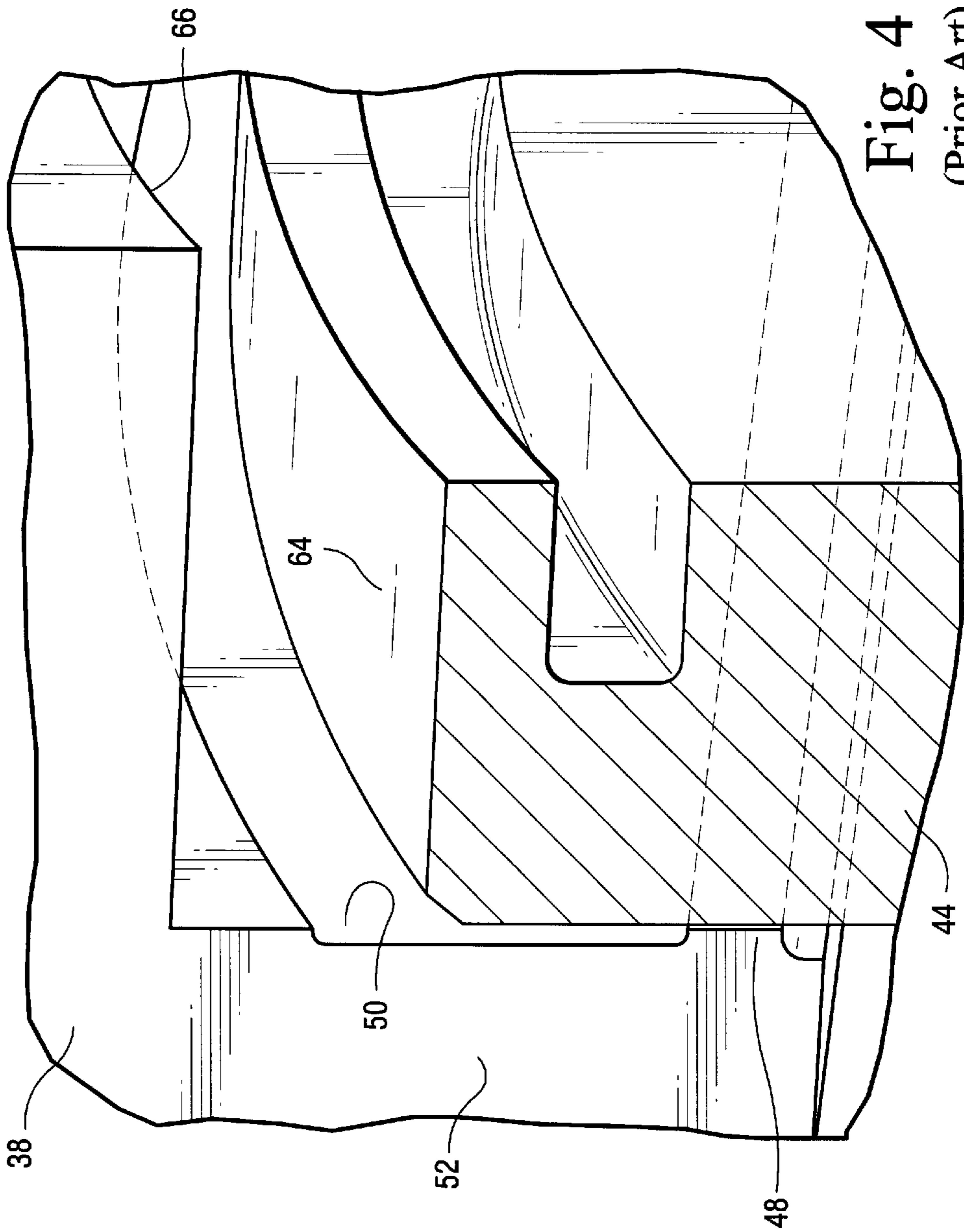

Fig. 4  
(Prior Art)

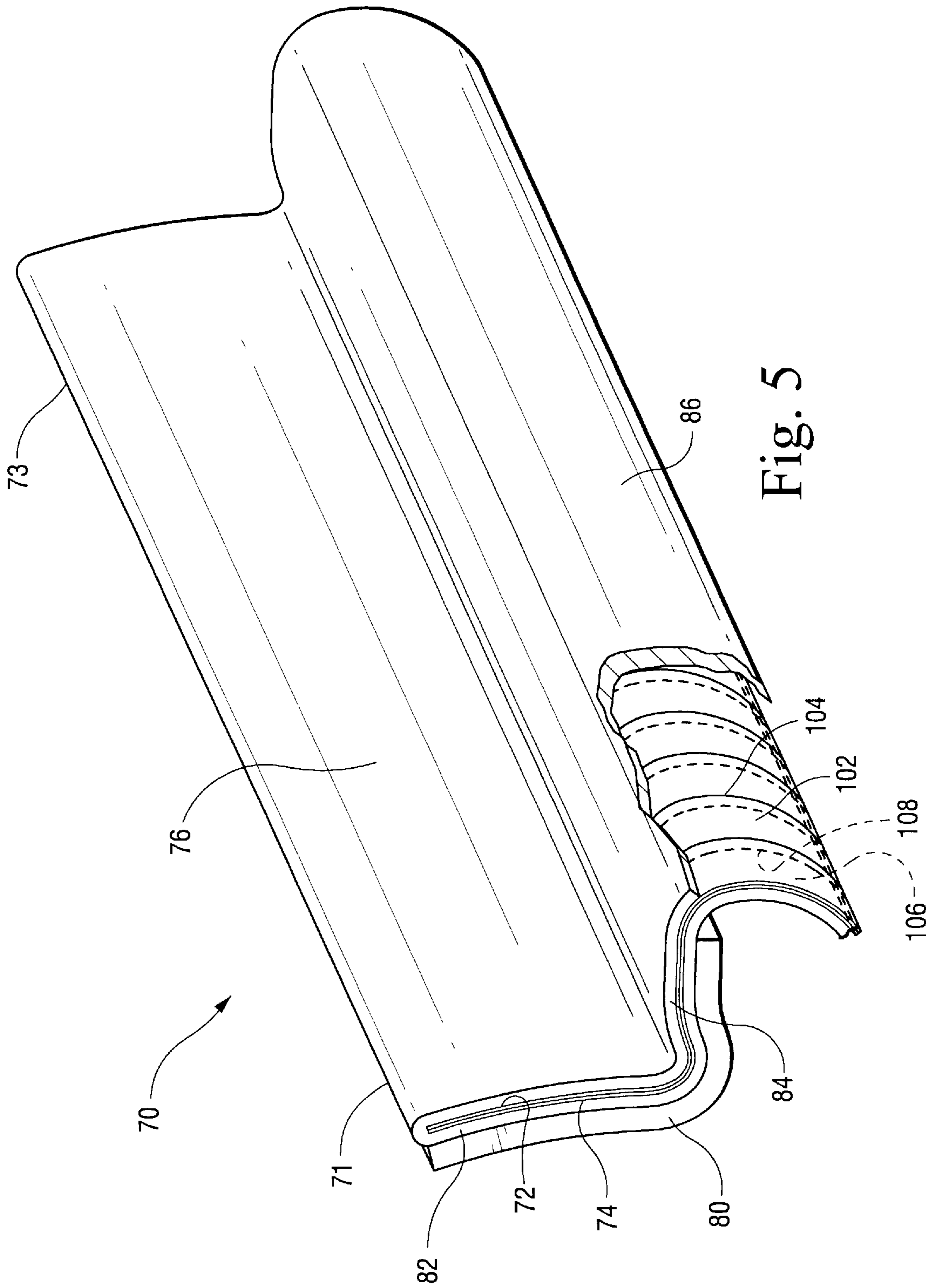

Fig. 5

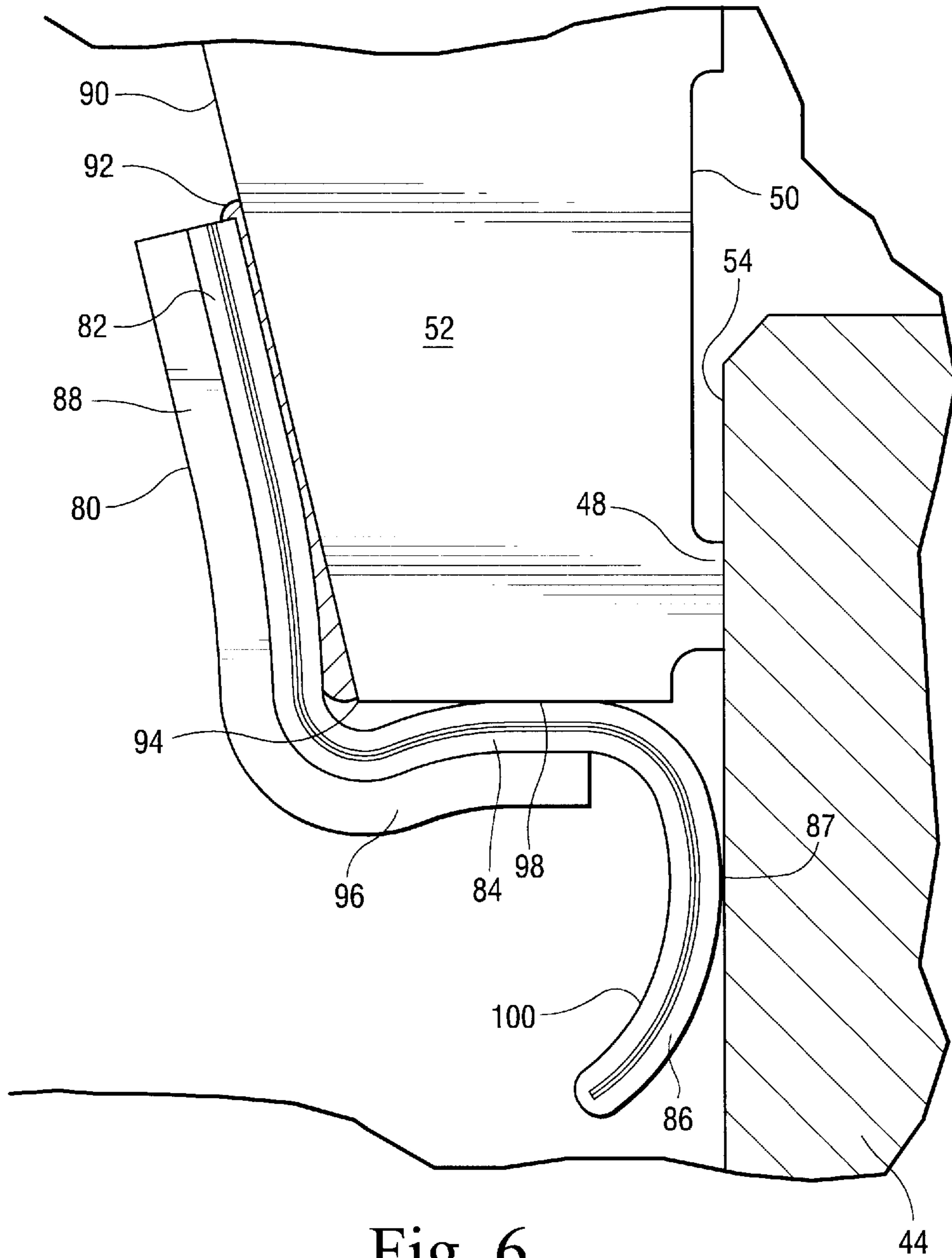

Fig. 6

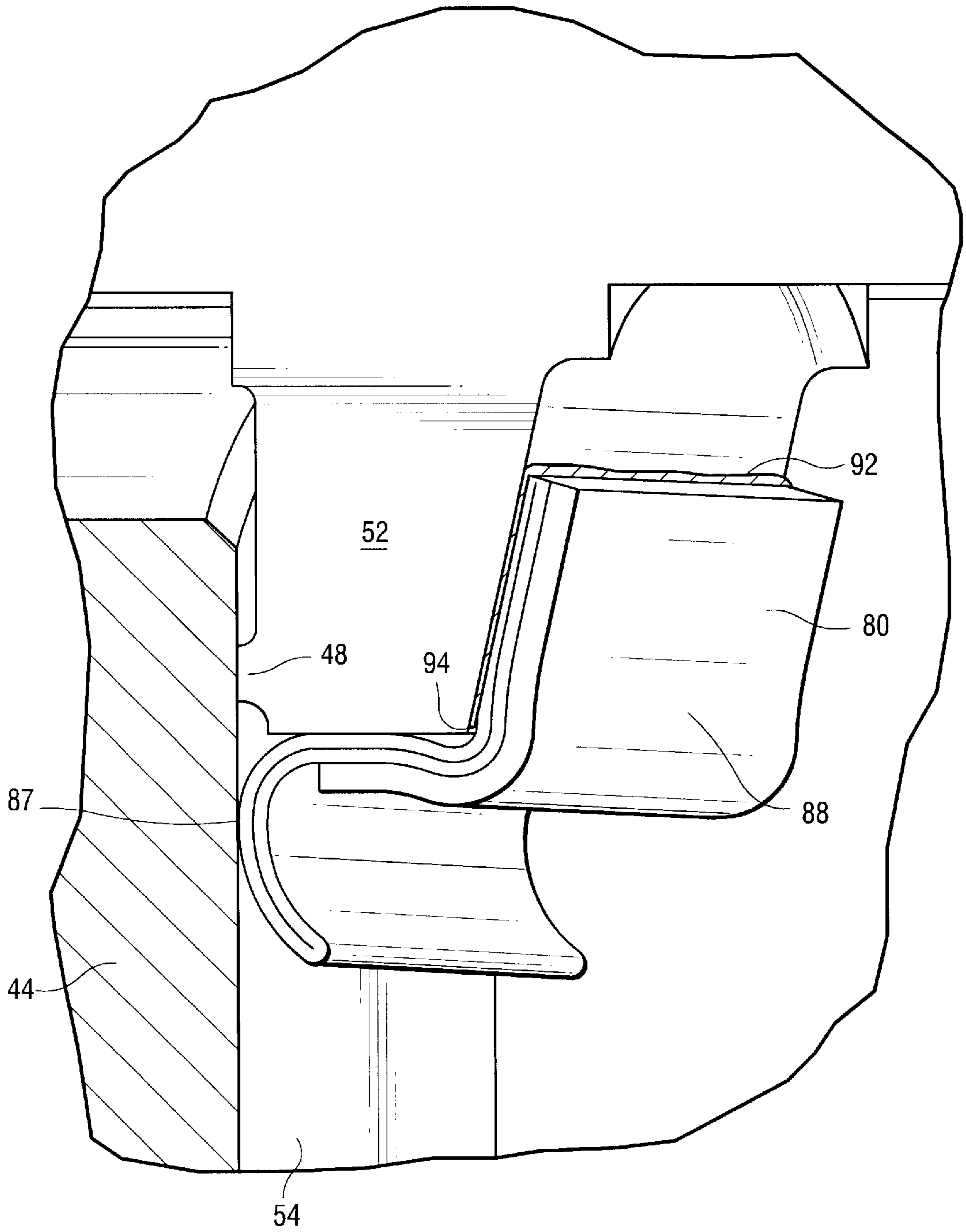

Fig. 7



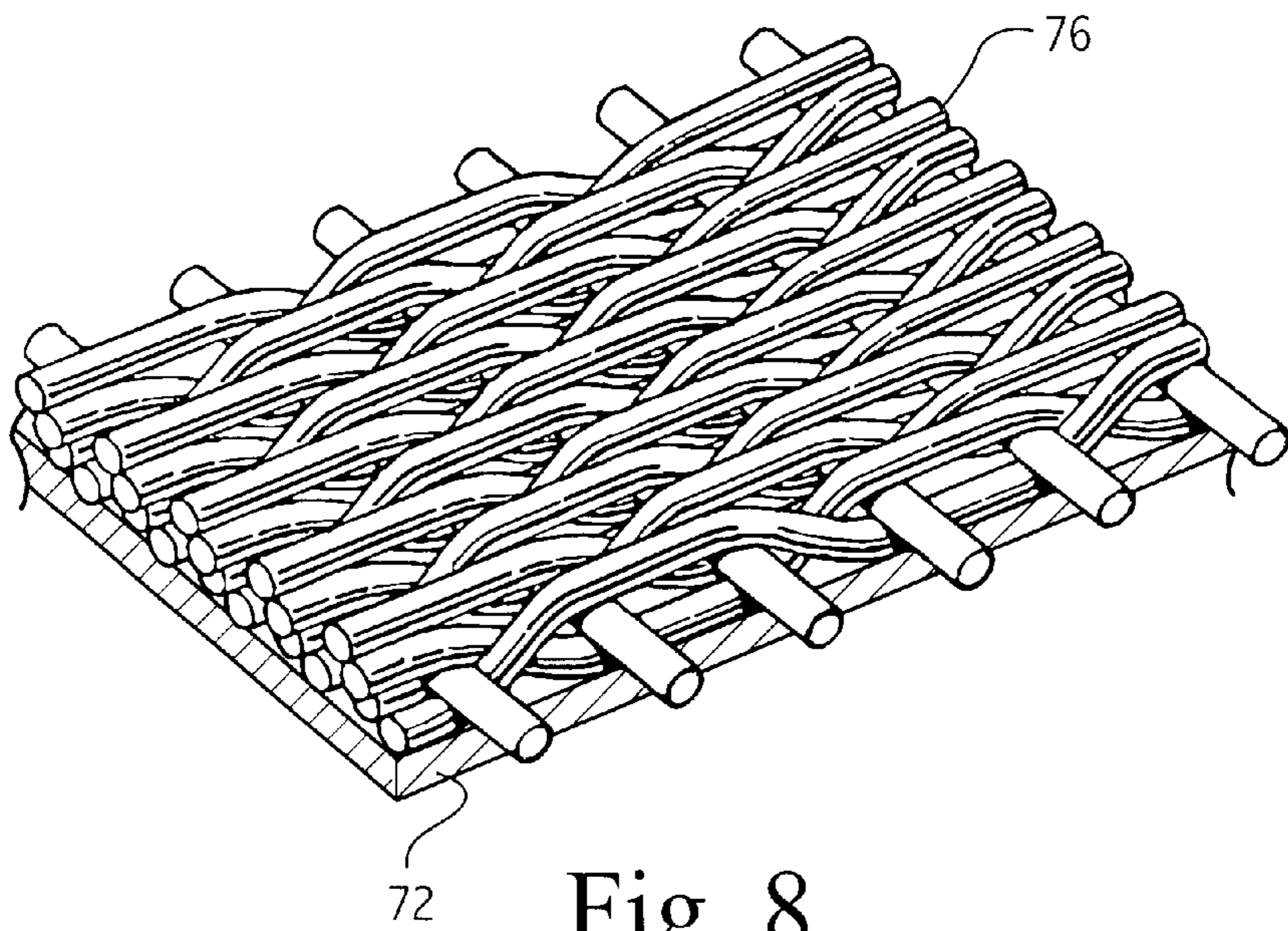

Fig. 8

## SUPPLEMENTAL SEAL FOR THE CHORDAL HINGE SEAL IN A GAS TURBINE

### BACKGROUND OF THE INVENTION

The present invention relates to seals in a gas turbine for supplementing the chordal hinge seals between turbine nozzles and a turbine nozzle support ring and particularly relates to supplementary seals for substantially minimizing or eliminating leakage losses past the chordal hinge seals.

In a gas turbine, hot gases of combustion flow from combustors through first-stage nozzles and buckets and through the nozzles and buckets of follow-on turbine stages. The first-stage nozzles typically include an annular array or assemblage of cast nozzle segments each containing one or more nozzle stator vanes per segment. Each first-stage nozzle segment also includes inner and outer band portions spaced radially from one another. Upon assembly of the nozzle segments, the stator vanes are circumferentially spaced from one another to form an annular array thereof between annular inner and outer bands. A nozzle retaining ring coupled to the outer band of the first-stage nozzles supports the first-stage nozzles in the gas flow path of the turbine. An annular nozzle support ring, preferably split at a horizontal midline, is engaged by the inner band and supports the first-stage nozzles against axial movement.

In an exemplary arrangement, eighteen cast segments are provided with two vanes per segment. The annular array of segments are sealed one to the other along adjoining circumferential edges by side seals. The side seals seal between a high pressure region radially inwardly of the inner band, i.e., compressor discharge air at high pressure, and the hot gases of combustion in the hot gas flow path which are at a lower pressure.

Chordal hinge seals are used to seal between the inner band of the first-stage nozzles and an axially facing surface of the nozzle support ring. Each chordal hinge seal includes an axial projection which extends linearly along a chordline of the inner band portion of each nozzle segment. Particularly, the chordal hinge seal extends along an inner rail of each segment and which rail extends radially inwardly of the inner band portion. The chordal hinge seal projection lies in sealing engagement with the axially opposite facing sealing surface of the nozzle support ring.

During operation and/or repair of the first-stage nozzle, it has been found that warpage can leave gaps between the chordal hinge seals and the sealing surface of the nozzle support ring. These gaps enable leakage past the chordal hinge seals from the high pressure area radially within the annular inner band into the hot gas flow path. That is, the chordal hinge seals are inadequate to prevent leakage flow as the chordal hinge seal projections lose contact with the sealing surface of the nozzle support ring. Consequently, there is a need for a supplemental seal at the interface of the first-stage nozzles and nozzle support ring to minimize or eliminate the leakage flow past the chordal hinge seals.

### BRIEF DESCRIPTION OF THE INVENTION

In accordance with a preferred embodiment of the present invention, there is provided a supplemental seal between the first-stage nozzles and the nozzle support ring which eliminates or minimizes leakage past the chordal hinge seals and which is readily and easily installed. In a preferred embodiment, the supplemental seal includes at least one and preferably two back-to-back sheet metal shims wrapped in a woven metallic cloth attached to the back side surface of the

inner rail of each nozzle segment. The supplemental seal extends from the back side surface of the inner rail for engagement against a first surface of the nozzle support ring at a location radially inwardly of the chordal hinge seal. The high pressure compressor discharge air in the high pressure region of the turbine biases the cloth seal against the annular surface of the nozzle support ring.

Particularly, the cloth seal and shims are secured along a support bracket, the supplemental seal being secured along the back side surface of the inner rail, preferably by welding. Each seal segment extends linearly in a chord-wise direction relative to the turbine axis and is provided in lengths corresponding to the circumferential extent of each inner rail. The supplemental seal segments are also secured along their end edges to the end edges of the inner rail.

The cloth and shims of each seal are shaped to project generally radially inwardly, turn in an axial direction toward the nozzle support ring passing inwardly of the inner rail, and turn again in a generally radial inward direction to form a distal leg on the inner end portion of the seals. The shims in the leg of each seal are slit back from their distal edge to form a plurality of fingers. The fingers of one shim leg overlie the slits between the fingers of the other shim leg. That is, the slits of the shims are staggered in a chord-wise direction relative to one another such that the slits of each shim leg are effectively sealed by the fingers of the opposing shim leg. The slits afford flexibility to the sealing surface of the supplemental seal leg.

In a preferred embodiment according to the present invention, there is provided a turbine comprising a turbine nozzle support ring having a generally axially facing first surface, a turbine nozzle segment having at least one stator vane and a radially inwardly extending inner rail having a second surface in axial opposition to the first surface, a seal depending from a side surface of the inner rail remote from the second surface and extending radially inwardly of the inner rail for sealing engagement against the first surface to form a seal therebetween, the seal including a seal segment having at least a first plate, an overlay of a woven metallic cloth and a distal margin covered by the cloth and engaging the first surface and a support bracket extending along at least a portion of one side of the seal body to support the seal segment on a side thereof remote from the inner rail, the margin of the seal segment being flexible and preloaded to seal against the first surface.

In a further preferred embodiment according to the present invention, there is provided a turbine comprising a turbine nozzle support ring having a generally axially facing first surface, a plurality of turbine nozzle segments each having at least one stator vane and a radially inwardly extending inner rail having a second surface in axial opposition to the first surface, a seal comprised of a plurality of seal segments each depending from a side surface of the inner rail remote from the second surface and extending radially inwardly of the inner rail for sealing engagement against the first surface to form a seal therewith, each seal segment including a first plate, an overlay of a woven metallic cloth and a distal margin covered by the cloth and engaging the first surface and a plurality of support brackets extending along one side of the seal segments to support the seal bodies on a high pressure side thereof, the margins of the seal bodies being flexible and preloaded to seal against the first surface.

### BRIEF DESCRIPTION OF THE DRAWINGS

FIG. 1 is a fragmentary schematic side elevational view of a portion of a gas turbine;

FIG. 2 is an enlarged fragmentary cross-sectional view illustrating a conventional chordal seal hinge;

FIG. 3 is a fragmentary perspective view illustrating a portion of a conventional chordal hinge seal along an inner rail of a nozzle segment;

FIG. 4 is a fragmentary perspective view with parts in cross-section illustrating the conventional chordal hinge seal in sealing engagement with a nozzle support ring of the gas turbine;

FIG. 5 is an enlarged perspective view illustrating a supplemental seal according to a preferred embodiment of the present invention;

FIG. 6 is a side elevational view of the supplemental seal of FIG. 5 installed in conjunction with the chordal hinge seal;

FIG. 7 is a fragmentary perspective view of the seal as viewed from the back side surface of the inner rail; and

FIG. 8 is a perspective view of a metallic cloth weave for the supplemental seal hereof.

#### DETAILED DESCRIPTION OF THE INVENTION

Referring now to FIG. 1, there is illustrated a representative example of a turbine section of a gas turbine, generally designated 10. Turbine 10 receives hot gases of combustion from an annular array of combustors, not shown, which transmit the hot gases through a transition piece 12 for flow along an annular hot gas path 14. Turbine stages are disposed along the hot gas path 14. Each stage comprises a plurality of circumferentially spaced buckets mounted on and forming part of the turbine rotor and a plurality of circumferentially spaced stator vanes forming an annular array of nozzles. For example, the first stage includes a plurality of circumferentially-spaced buckets 16 mounted on a first-stage rotor wheel 18 and a plurality of circumferentially-spaced stator vanes 20. Similarly, the second stage includes a plurality of buckets 22 mounted on a rotor wheel 24 and a plurality of circumferentially-spaced stator vanes 26. Additional stages may be provided, for example, a third stage comprised of a plurality of circumferentially-spaced buckets 28 mounted on a third-stage rotor wheel 30 and plurality of circumferentially-spaced stator vanes 32. It will be appreciated that the stator vanes 20, 26 and 32 are mounted on and fixed to a turbine casing, while the buckets 16, 22 and 28 and wheels 18, 24 and 30 form part of the turbine rotor. Between the rotor wheels are spacers 34 and 36 which also form part of the turbine rotor. It will be appreciated that compressor discharge air is located in a region 37 disposed radially inwardly of the first stage and that such air in region 37 is at a higher pressure than the pressure of the hot gases flowing along the hot gas path 14.

Referring to the first stage of the turbine, the stator vanes 20 forming the first-stage nozzles are disposed between inner and outer bands 38 and 40, respectively, supported from the turbine casing. As noted above, the nozzles of the first stage are formed of a plurality of nozzle segments 41 (FIG. 3) each mounting one, preferably two, stator vanes extending between inner and outer band portions and arranged in an annular array of segments. A nozzle retaining ring 42 connected to the turbine casing is coupled to the outer band and secures the first-stage nozzle. A nozzle support ring 44 radially inwardly of the inner band 38 of the first-stage nozzles engages the inner band 38. Particularly, the interface between the inner band 38 and the nozzle support ring 44 includes an inner rail 52 (FIG. 2). The inner rail 52 includes a chord-wise, linearly extending axial projection 48, generally and collectively hereinafter referred to as a chordal hinge seal 46. Projection 48 extends along an

axial facing surface 50 of the inner rail 52 which forms an integral part of each nozzle segment and specifically the inner band 38. The projection 48 engages a first annular surface 54 of the nozzle support ring 44. It will be appreciated that high pressure compressor discharge air lies in the region 37 and lower pressure hot gases flowing in the hot gas path 14 lie on the opposite side of the seal 48. The chordal hinge seal 46 is thus intended to seal against leakage from the high pressure region 37 into the lower pressure region of the hot gas path 14.

As noted previously, however, when operating the turbine, component parts of the nozzles and nozzle support ring will tend to form leakage gaps between the projections 48 and the surface 54 of the nozzle support ring 44 whereby leakage flow may occur from the high pressure region to the low pressure region. In order to minimize or prevent leakage flow into the hot gas path 14, and in accordance with a preferred embodiment of the present invention, there is provided a supplemental seal for sealing between the first-stage nozzles and the nozzle support ring 44. The supplemental seal, generally designated 70 (FIG. 5), is provided in seal segments 73. Each segment 73 includes a linearly extending cloth seal 71 formed by arcuately extending back-to-back sheet metal shims wrapped in preferably a woven metallic cloth and secured to the first-stage nozzle. Particularly, the supplemental seal 70 includes one, and preferably a pair of sheet metal plates or shims 72 and 74 overlaid on both sides by a woven metallic cloth 76. Seal 70 also includes a structural support bracket 80 which extends linearly along one side of the seal and provides a rigid support for the seal. The metallic cloth and shims are integrally secured to the bracket 80 along the interfaces of the bracket 80 and cloth seal 71, for example, by welding.

To support the supplemental seal 70 from the nozzle segments and to seal against the annular surface 54 of the nozzle support ring 44, the cloth seal 71 is shaped to provide back, central and leg portions 82, 84 and 86, respectively. The back portion 82 is disposed between a correspondingly-shaped back portion 88 of the bracket 80 and a back side surface 90 of the inner rail 52 remote from surface 50 and secured along surface 90, e.g., by welding at 92. As illustrated in FIGS. 6 and 7, the lateral ends or side end edges 94 of the cloth seal 71 extend to the end edges of the inner rail 52 and are secured along those edges, preferably by welding. The back portion 82 of seal 70 projects generally radially inwardly along the back side surface 90 of the inner rail 52 and is spaced or bent outwardly from an innermost edge 94 of the inner rail 52 at the juncture of the back and central portions 82 and 84, respectively.

As illustrated in FIG. 6, the central portion 84 of cloth seal 71 lies between an axially extending portion 96 of bracket 80 and an innermost surface 98 along inner rail 52. The cloth seal 72 then projects toward the sealing surface 54 and turns inwardly to form the leg portion 86 which seals against surface 54. Thus, the cloth seal 71 is bent or folded in a radial inward direction at the juncture of the central and leg portions 84 and 86, respectively, to form a generally linearly extending seal 87 along a distal margin 100 thereof. The sealing leg portion 86 bears against the sealing surface 54 with the woven metallic cloth in contact with the surface 54, effecting a supplemental seal. It will be appreciated that the shims 72 and 74 are also preloaded to maintain the sealing leg portion 86 in sealing engagement against the surface 54.

As best illustrated in FIG. 5, the shims 72 and 74 along the leg portion 86 are slit at laterally spaced locations along the seal 70 to form fingers 102 and 106, respectively. For example, the shim 72 is slit at 104 at chord-wise spaced locations therealong to form discrete fingers 104. The shim 74 is likewise slit at 108 at chord-wise spaced locations therealong to form discrete fingers 106. The slits 104 and

5

108 are staggered in a chord-wise direction relative to one another such that fingers 102 formed by the slits 104 of shim 72 overlies the slits 106 between the fingers 108 of the shim 74. Thus, the fingers 106 of shim 74 underlie the slits 104 of shim 72. The fingers 104 and 106 thus render the leg portion 86 of the supplemental seal 70 flexible, thereby affording a good seal 87 with the sealing surface 54. The overlapping of the slits by the fingers also affords a sealing action inhibiting flow between the slits.

Referring to FIG. 8, there is illustrated a portion of a preferred metallic cloth 76 overlaying a shim, for example, shim 72. The cloth overlay is in the form of a Dutch twill weave. With the cloth formed of L605 or Haynes 188 material and with the relatively dense weave, effective seal and wear surfaces are provided.

The supplemental seal segments 73 are provided preferably in the same number as the number of nozzle segments. Consequently, the supplemental seal segments 73 overlies the joints between the nozzle segments 41 and butt endwise with one another, thereby to reduce nozzle inter-segment leakage as well as the leakage past the chordal hinge seals. It will be appreciated that the supplemental seals 70 are subjected to the high pressure of region 37. Seals 70 are thus biased into sealing engagement with the surface 54 of the nozzle support 44 by the pressure differential on opposite sides thereof.

While the invention has been described in connection with what is presently considered to be the most practical and preferred embodiment, it is to be understood that the invention is not to be limited to the disclosed embodiment, but on the contrary, is intended to cover various modifications and equivalent arrangements included within the spirit and scope of the appended claims.

What is claimed is:

1. A turbine comprising:

a turbine nozzle support ring having a generally axially facing first surface;

a turbine nozzle segment having at least one stator vane and a radially inwardly extending inner rail having a second surface in axial opposition to said first surface;

a seal depending from a side surface of said inner rail remote from said second surface and extending radially inwardly of said inner rail for sealing engagement against said first surface to form a seal therebetween; said seal including a seal segment having at least a first plate, an overlay of a woven metallic cloth and a distal margin covered by said cloth and engaging said first surface; and

a support bracket extending along at least a portion of one side of said seal body to support said seal segment on a side thereof remote from said inner rail, said margin of said seal segment being flexible and preloaded to seal against said first surface.

2. A turbine according to claim 1 wherein said seal segment includes a second plate, said plates lying back-to-back with one another, said cloth extending as an overlay along opposite sides of said first and second plates.

3. A turbine according to claim 2 wherein said seal extends linearly in a chord-wise direction along said inner rail, said plates having slits extending from edges thereof and along said margin to provide flexibility to said seal.

4. A turbine according to claim 3 wherein the slits along a margin of said first plate and the slits along a margin of said second plate are staggered relative to one another in a chordal direction about the rotor axis.

5. A turbine according to claim 1 wherein said inner rail has a projection extending axially from said inner rail for sealing engagement against said first surface and forming a second seal therewith.

6

6. A turbine according to claim 5 wherein said projection extends linearly along said inner rail.

7. A turbine according to claim 6 wherein said sealing engagement between said projection and said first surface lies on a low pressure side of the first-mentioned seal.

8. A turbine according to claim 7 wherein the first seal extends linearly in a chord-wise direction about the axis of the turbine.

9. A turbine according to claim 8 wherein said seal is welded to said side surface of said inner rail and along opposite end edges of said seal to opposite ends of said inner rail.

10. A turbine comprising:

a turbine nozzle support ring having a generally axially facing first surface;

a plurality of turbine nozzle segments each having at least one stator vane and a radially inwardly extending inner rail having a second surface in axial opposition to said first surface;

a seal comprised of a plurality of seal segments each depending from a side surface of said inner rail remote from said second surface and extending radially inwardly of said inner rail for sealing engagement against said first surface to form a seal therewith;

each said seal segment including a first plate, an overlay of a woven metallic cloth and a distal margin covered by said cloth and engaging said first surface; and

a plurality of support brackets extending along one side of said seal segments to support said seal bodies on a high pressure side thereof, said margins of said seal bodies being flexible and preloaded to seal against said first surface.

11. A turbine according to claim 10 wherein each said seal segment includes a second plate, said first and second plates of each said seal body lying back-to-back with one another, said cloth extending as an overlay along opposite sides of said first and second plates.

12. A turbine according to claim 10 wherein each of said seal segments extends in a chord-wise direction and has a chord-wise extent corresponding to the chord-wise extent of each inner rail.

13. A turbine according to claim 10 wherein each said seal segment includes a second plate, said first and second plates of each said seal body lying back-to-back with one another, said cloth extending as an overlay along opposite sides of said first and second plates, each said seal extending linearly about an axis of the turbine, said plates having slits extending from edges thereof and along said margin to provide flexibility to said seal.

14. A turbine according to claim 13 wherein the slits along a margin of said first plate and the slits along a margin of said second plate in each seal segment are staggered relative to one another in a chord-wise direction along the inner rail.

15. A turbine according to claim 10 wherein said inner rail has a projection extending axially therefrom for sealing engagement against said first surface and forming a second seal therewith.

16. A turbine according to claim 15 wherein said projections extend linearly along said inner rails.

17. A turbine according to claim 16 wherein said sealing engagement between said projections and said first surface lies on a low pressure side of the first-mentioned seal.

18. A turbine according to claim 16 wherein the first seal extends linearly in a chord-wise direction relative to the axis of the turbine.