



US006586150B2

(12) **United States Patent  
Proper**

(10) **Patent No.: US 6,586,150 B2**  
(45) **Date of Patent: Jul. 1, 2003**

(54) **METHOD OF BLENDING TONERS WITH AN  
IMPROVED BLENDING TOOL**

(75) Inventor: **James M. Proper**, Webster, NY (US)

(73) Assignee: **Xerox Corporation**, Stamford, CT  
(US)

(\* ) Notice: Subject to any disclaimer, the term of this  
patent is extended or adjusted under 35  
U.S.C. 154(b) by 0 days.

(21) Appl. No.: **10/173,193**

(22) Filed: **Jun. 14, 2002**

(65) **Prior Publication Data**

US 2002/0155371 A1 Oct. 24, 2002

**Related U.S. Application Data**

(62) Division of application No. 09/748,920, filed on Dec. 27,  
2000, now Pat. No. 6,523,996.

(51) **Int. Cl.**<sup>7</sup> ..... **B01F 7/18; G03G 9/08**

(52) **U.S. Cl.** ..... **430/137.1; 366/314; 430/137.21**

(58) **Field of Search** ..... **430/137.1, 137.21**

(56) **References Cited**

**U.S. PATENT DOCUMENTS**

377,546 A \* 2/1888 Crane  
739,422 A \* 9/1903 Jones  
1,111,715 A \* 9/1914 Hood  
1,536,203 A \* 5/1925 Frydenlund  
3,090,606 A \* 5/1963 Burnet  
3,245,663 A \* 4/1966 Austin  
3,545,729 A \* 12/1970 Wisseroth et al.  
3,944,493 A 3/1976 Jadwin et al.  
4,007,293 A 2/1977 Mincer et al.  
4,054,465 A 10/1977 Ziobrowski  
4,079,014 A 3/1978 Burness et al.  
4,281,934 A \* 8/1981 Krause et al.  
4,298,672 A 11/1981 Lu  
4,338,380 A 7/1982 Erickson et al.  
4,394,430 A 7/1983 Jadwin et al.  
4,433,040 A 2/1984 Niimura et al.

4,438,634 A \* 3/1984 Merle et al.  
4,456,382 A \* 6/1984 Mahler, II  
4,571,091 A \* 2/1986 Pardo et al.  
4,674,887 A \* 6/1987 Lucke et al.  
4,721,394 A \* 1/1988 Casto et al.  
4,790,667 A \* 12/1988 Pardo et al.  
4,845,003 A 7/1989 Kiriu et al.  
4,894,308 A 1/1990 Mahabadi et al.  
4,937,157 A 6/1990 Haack et al.  
4,937,439 A 6/1990 Wanninger et al.  
5,009,510 A \* 4/1991 Gabriele  
5,326,168 A \* 7/1994 Miura  
5,370,962 A 12/1994 Anderson et al.  
5,393,139 A \* 2/1995 Thorson et al.  
5,624,079 A 4/1997 Higuchi et al.  
5,692,831 A \* 12/1997 Campbell  
5,707,145 A \* 1/1998 Lucke et al.  
5,716,751 A 2/1998 Bertrand et al.  
5,763,132 A 6/1998 Ott et al.  
5,785,424 A \* 7/1998 Noda et al.  
5,813,837 A \* 9/1998 Yamamoto et al.  
5,874,034 A 2/1999 Proper et al.  
5,888,691 A \* 3/1999 Laing et al. .... 430/137  
5,912,101 A \* 6/1999 Karaki et al. .... 430/110  
5,981,269 A \* 11/1999 Park  
5,998,079 A 12/1999 Thompson et al.  
6,322,244 B1 \* 11/2001 Marchesini et al.  
6,334,704 B2 \* 1/2002 Noda et al.  
6,341,889 B1 \* 1/2002 Noda et al.

**FOREIGN PATENT DOCUMENTS**

DE 4221315 \* 1/1994

\* cited by examiner

*Primary Examiner*—John Goodrow  
(74) *Attorney, Agent, or Firm*—Richard F Spooner

(57) **ABSTRACT**

An improved blending tool with an enlarged collision profile and method of use by rotation in a blending machine. The improved blending tool comprises an enlarged collision surface fixed at the end of the tool's center shank wherein at least half of the trailing surface of the collision surface is negatively sloped.

**17 Claims, 6 Drawing Sheets**

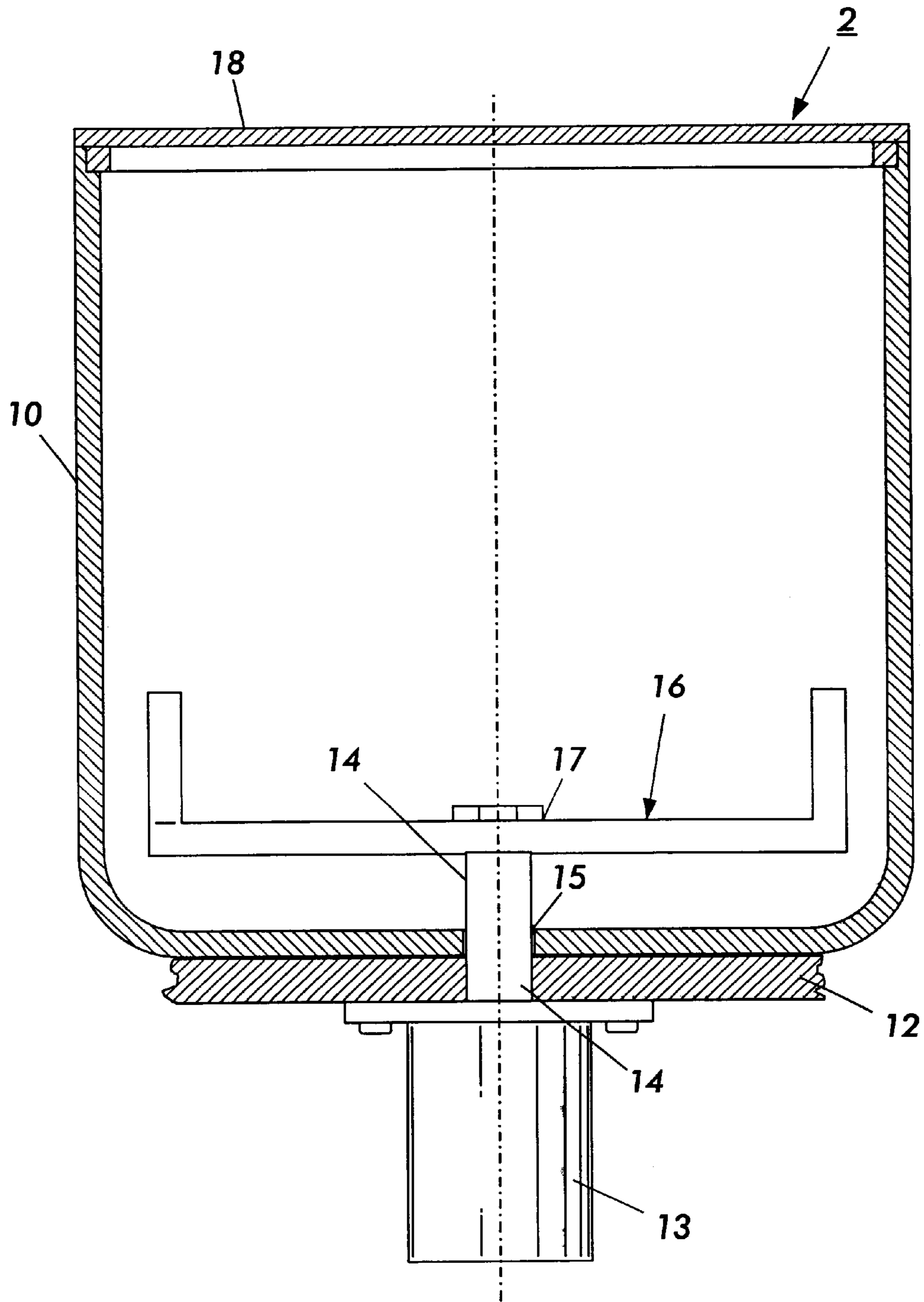

**FIG. 1**  
PRIOR ART

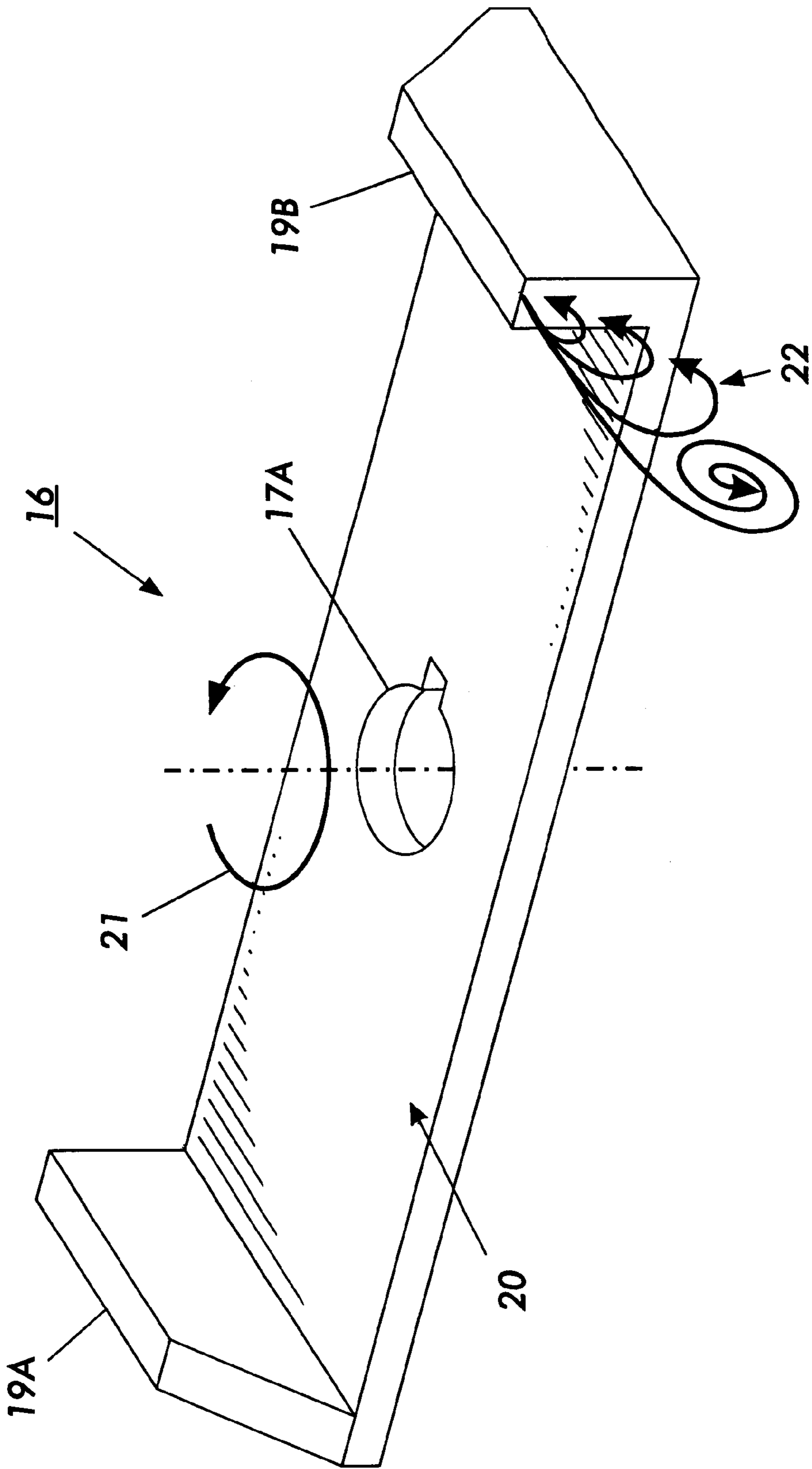

**FIG. 2**  
PRIOR ART

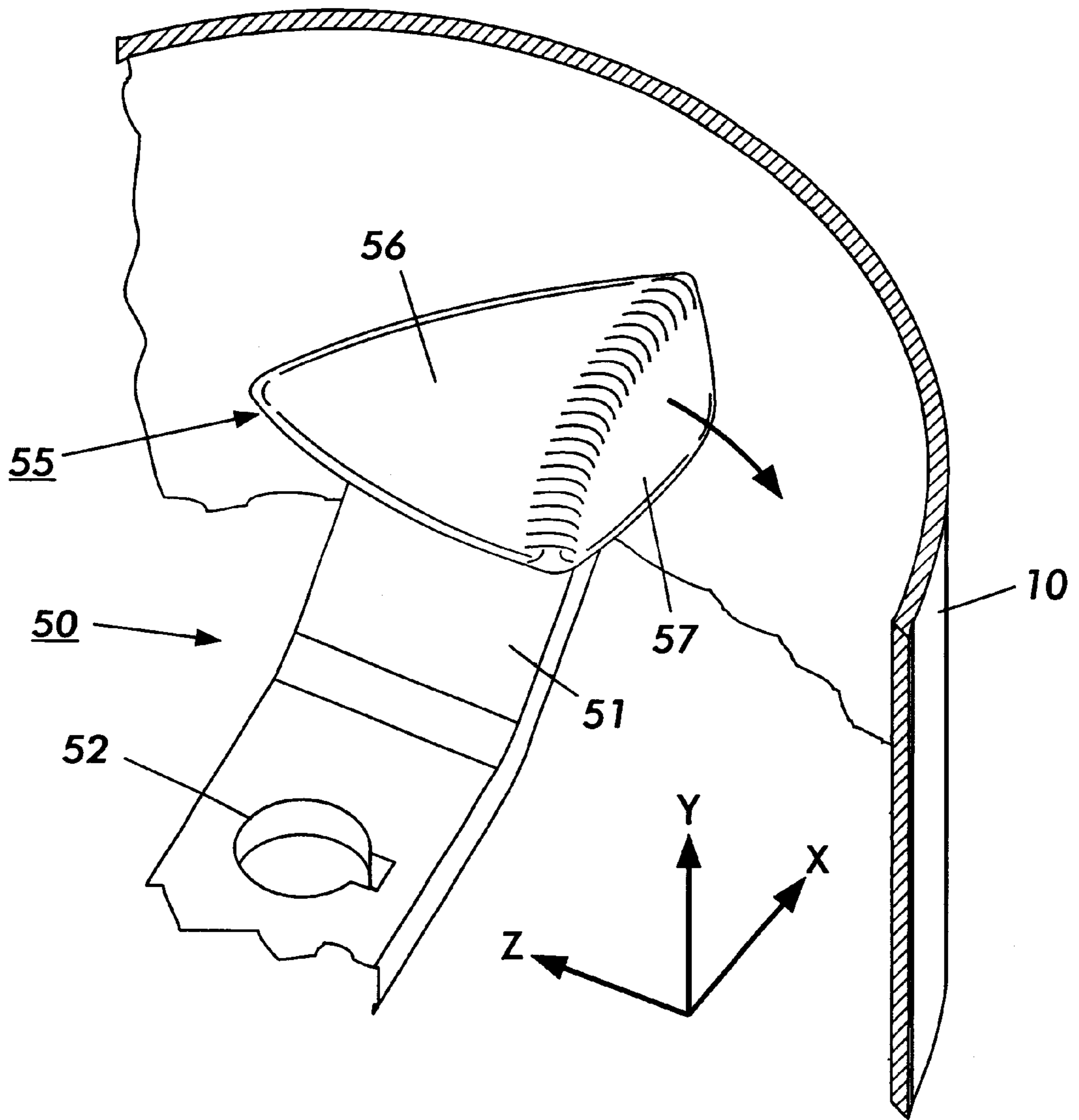
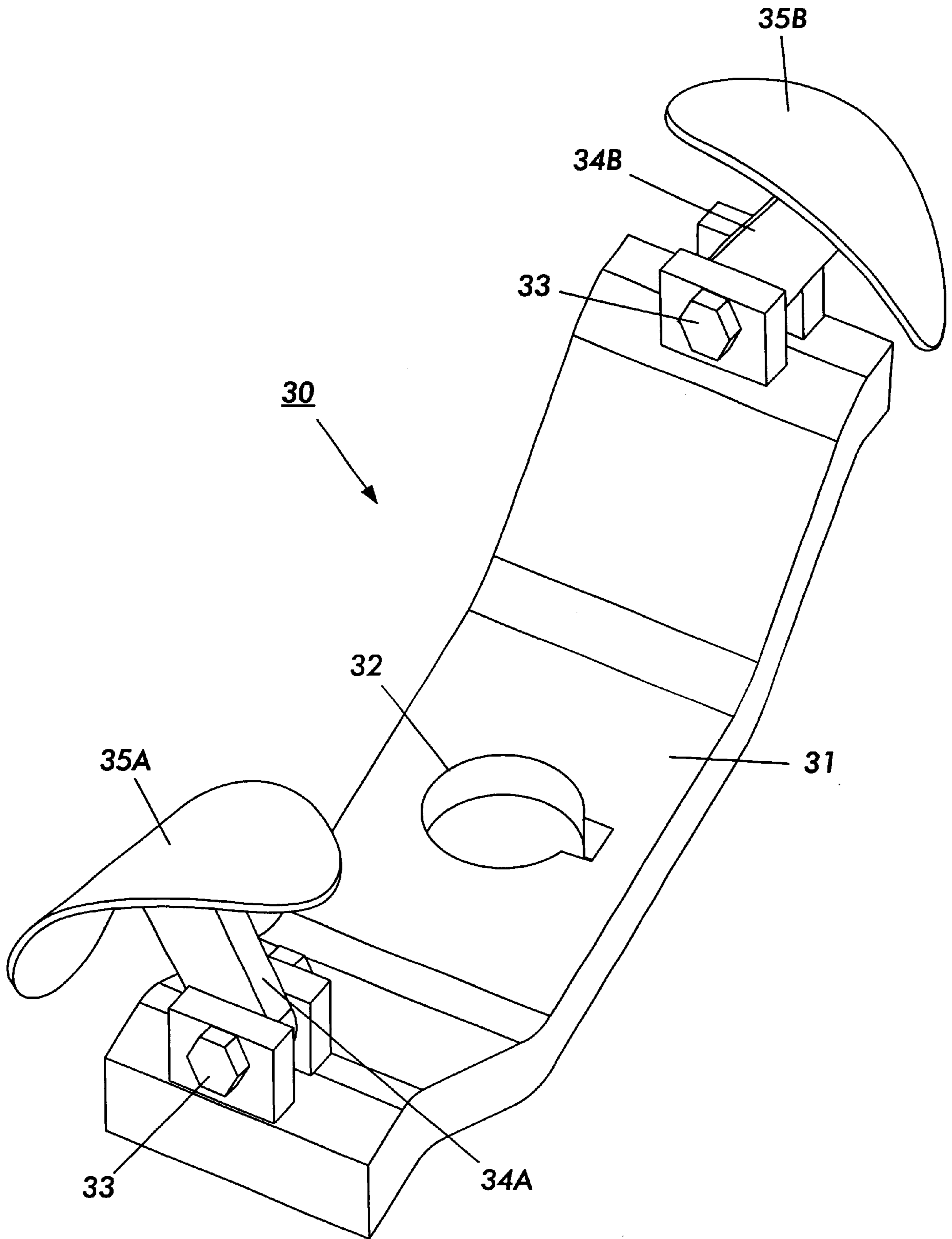

FIG. 3



**FIG. 4**

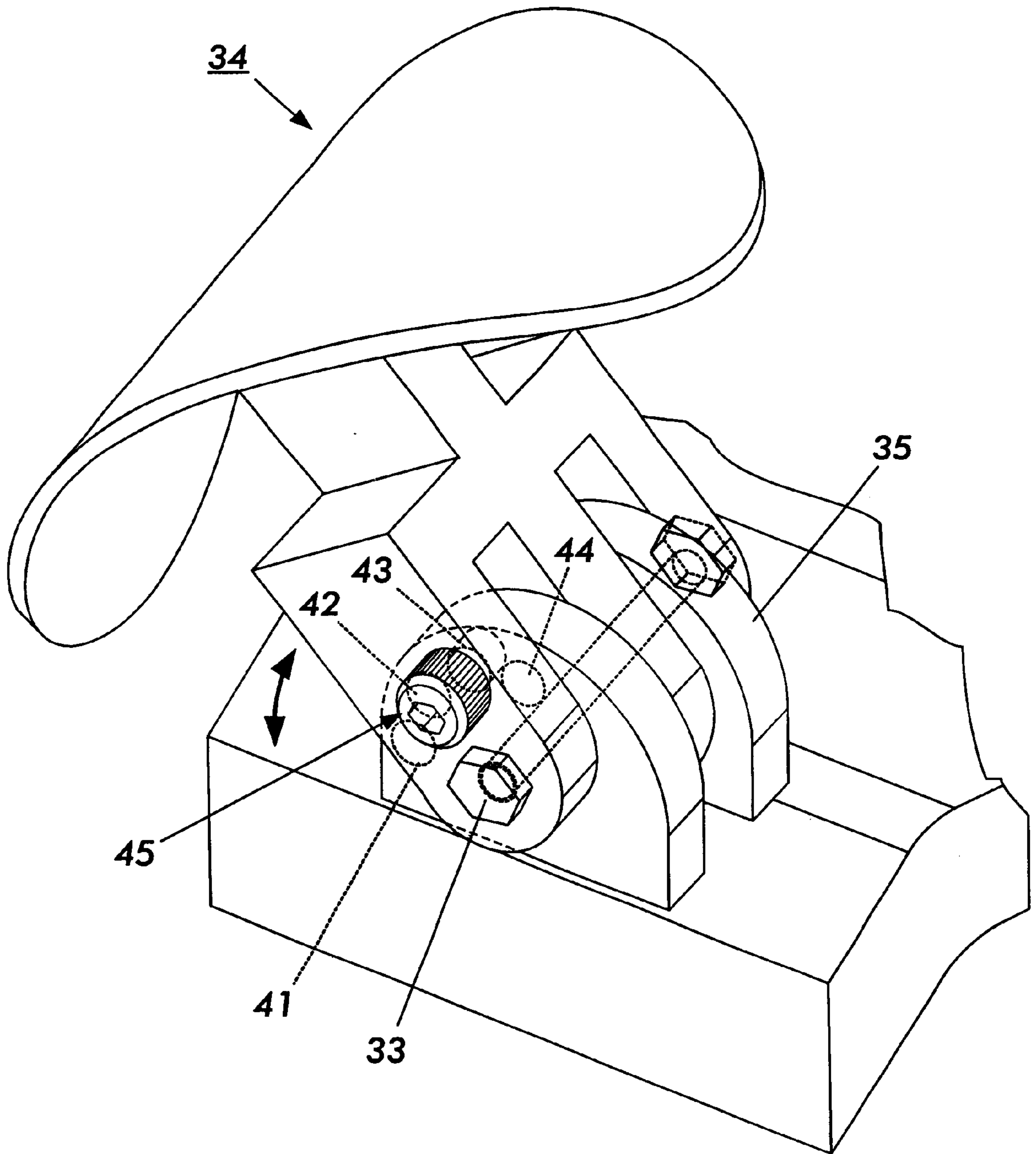

FIG. 5

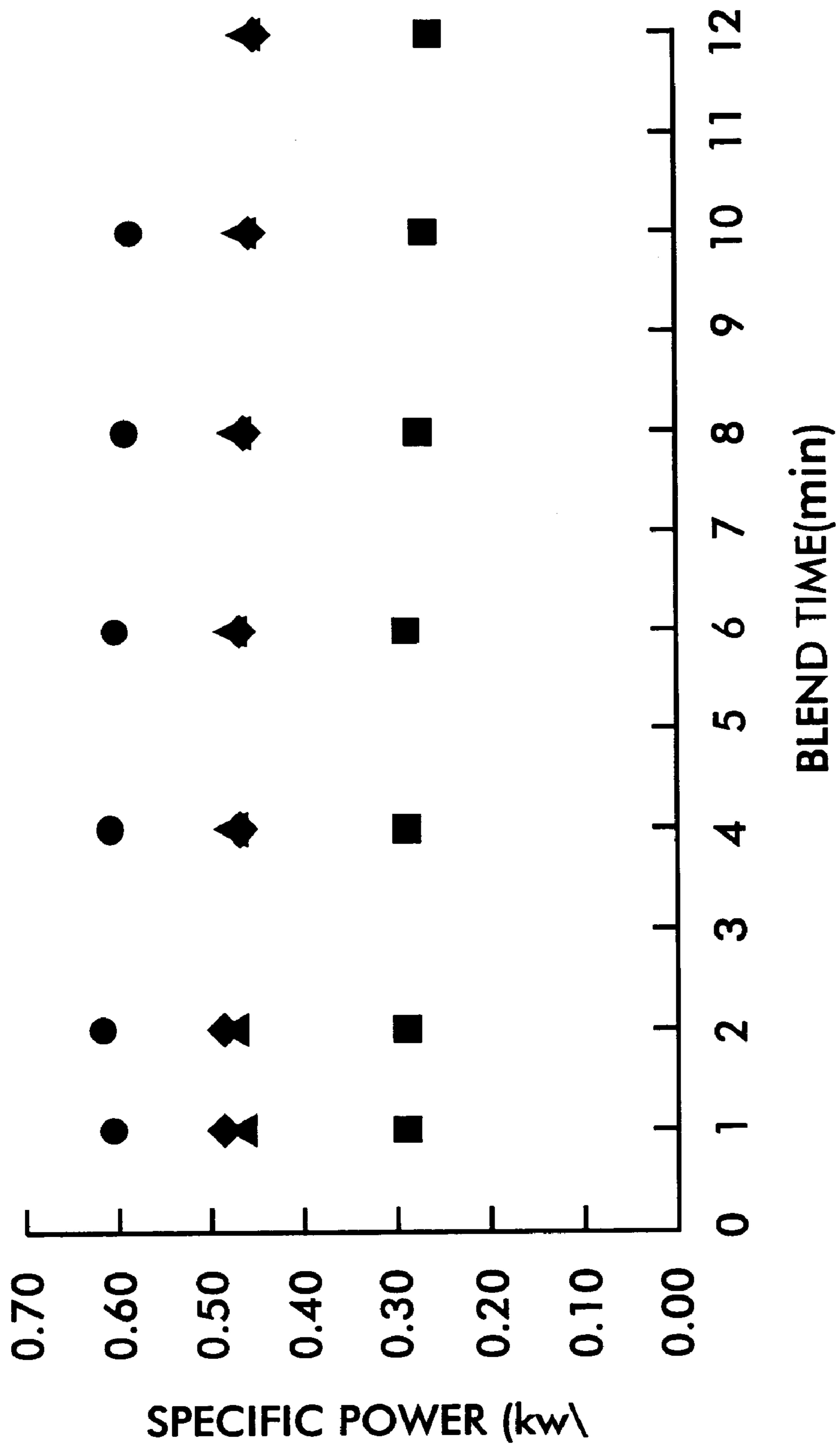

FIG. 6

## METHOD OF BLENDING TONERS WITH AN IMPROVED BLENDING TOOL

### CROSS-REFERENCE TO RELATED APPLICATIONS

This is a divisional of application Ser. No. 09/748,920; filed Dec. 27, 2000 now U.S. Pat. No. 6,523,996.

### CROSS-REFERENCE TO COPENDING APPLICATIONS

Attention is directed to commonly owned and assigned copending Application Number:

U.S. Ser. No. 09/749,059, filed Dec. 27, 2000 entitled "BLENDING TOOL WITH AN ADJUSTABLE COLLISION PROFILE AND METHOD OF ADJUSTING THE COLLISION PROFILE" and U.S. Ser. No. 10/024,196 filed, Dec. 21, 2001, entitled "AN IMPROVED TONER WITH INCREASED AMOUNT OF SURFACE ADDITIVES AND INCREASED SURFACE ADDITIVE ADHESION" and U.S. Ser. No. 09/748,920, now U.S. Pat. No. 6,523,996 filed Dec. 27, 2002, entitled: BLENDING TOOL WITH AN ENLARGED COLLISION SURFACE FOR INCREASED BLEND INTENSITY AND METHOD OF BLENDING TONERS.

### BACKGROUND OF THE INVENTION

The field of the proposed invention relates to high intensity blending apparatus and processes, particularly for blending operations designed to cause additive materials to become affixed to the surface of base particles. More particularly, the proposed invention relates to an improved method for producing surface modifications to electrophotographic and related toner particles.

High speed blending of dry, dispersed, or slurried particles is a common operation in the preparation of many industrial products. Examples of products commonly made using such high-speed blending operations include, without limitation, paint and colorant dispersions, pigments, varnishes, inks, pharmaceuticals, cosmetics, adhesives, food, food colorants, flavorings, beverages, rubber, and many plastic products. In some industrial operations, the impacts created during such high-speed blending are used both to uniformly mix the blend media and, additionally, to cause attachment of additive chemicals to the surface of particles (including resin molecules or conglomerates of resins and particles) in order to impart additional chemical, mechanical, and/or electrostatic properties. Such attachment between particles is typically caused by both mechanical impaction and electrostatic bonding between additives and particles as a result of the extreme pressures created by particle/additive impacts within the blender device. Among the products wherein attachments between particles and/or resins and additive particles are important during at least one stage of manufacture are paint dispersions, inks, pigments, rubber, and certain plastics.

A typical blending machine and blending tool of the prior art is exemplified in FIGS. 1 and 2. FIG. 1 is a schematic elevational view of a blending machine 2. Blending machine 2 comprises a vessel 10 into which materials to be mixed and blended are added before or during the blending process. Housing base 12 supports the weight of vessel 10 and its contents. Motor 13 is located within housing base 12 such that its drive shaft 14 extends vertically through an aperture in housing 12. Shaft 14 also extends into vessel 10 through sealed aperture 15 located at the bottom of vessel 10. Shaft

14 is fitted with a locking fixture 17 at its end, and blending tool 16 is rigidly attached to shaft 14 by locking fixture 17. Before blending is commenced, lid 18 is lowered and fastened onto vessel 10 to prevent spillage. For high intensity blending, the speed of the rotating tool at its outside edge generally exceeds 50 ft./second. The higher the speed, the more intense, and tool speeds in excess of 90 ft./second, or 100 ft./second are common.

Turning now to FIG. 2, a perspective view of blending tool 16 of the prior art is shown. Center shank 20 has a central fixture 17A for engagement by locking fixture 17 (shown in FIG. 1). In the example shown, the central fixture 17A is a simple notched hole for receiving a male fixture 17 (from FIG. 1) having the same dimensions. Arrow 21 shows the direction in which tool 16 rotates upon shaft 14. Vertical surfaces 19A and 19B are fixed to the end of center shank 20 in order to increase the surface area of the tool at its point of greatest velocity. This increases the tool's "intensity", or number of collisions per unit of time. In addition to the surface area of the tool's face, the intensity of a tool is influenced by tool speed and the shape of the tool. The importance of the shape of the tool will be discussed below. Vertical surfaces 19A and 19B combined with the leading edge of center shank 20 are the surfaces of tool 16 that collide with particles mixed within vessel 10 (shown in FIG. 1). The area through which these surfaces 19 and leading edge of center shank 20 sweep during rotation of tool 16 can be thought of as the working profile of the tool. In other words, the "profile" of a tool equals the 2-dimensional area outlined by collision surfaces of the tool as it sweeps through a plane that includes the rotational axis of shaft 14. In FIG. 2, the space or zone immediately behind rotating tool 16 is labeled 22.

Various shapes and thicknesses of blending tools and collision surfaces are possible. Various configurations are shown in the brochures and catalogues offered by manufacturer's of high-speed blending equipment such as Henschel, Littleford Day Inc., and other vendors. The tool shown in FIG. 2 is based upon a tool for high intensity blending produced by Littleford Day, Inc. Among the reasons for different configurations of blending tools are (i) different viscosities often require differently shaped tools to efficiently utilize the power and torque of the blending motor; and (ii) different blending applications require different intensities of blending. For instance, some food processing applications may require a very fine distribution of small solid particles such as colorants and flavorings within a liquid medium. Similarly, the processing of snow cones requires rapid and very high intensity blending designed to shatter ice cubes into small particles which are then mixed within the blender with flavored syrups to form a slurry.

Most high-speed blending tools of the prior art do not have raised vertical elements such as surfaces 19A and 19B (collectively "surface 19") shown in FIG. 2. Instead, a typical blending tool has a collision surface formed simply by the leading edge of its central shank 20. In many tools, the leading edge is rounded or arcuately shaped in order to avoid a "snow plow" effect wherein particles become caked upon a flat leading face much as snow is compressed and forms piles in front of a snow plow. The tool shown in FIG. 2 attempts to avoid this snow plow effect on raised collision surfaces 19 by slanting the forward face of surfaces 19 at an acute angle, thereby causing particles to either bounce upward from the tool or be swept by friction upward along the face of the tool until carried over its top and into the lee of the tool. However, a problem with the tool shown in FIG. 2 and with other tools in the prior art is that an enlarged



collision surface tends to create vortices in the wake of the tool as well as to decrease the overall density of particles in the zone **22** behind the tool. The degree of such density variations depends primarily upon the speed of the tool through the particle mixture as well as the height, width, and depth of the collision surface **19**.

Because of the above snow plow, vortex, and density limitations, conventional tools such as shown in FIG. **2** are limited both in height and in the width of any enlarged collision surface. Indeed, it is believed that in tools of the prior art that have elements raised above center shank **20**, the height (defined below as the y-axis dimension) of such vertically raised elements is less than the depth (defined below as the z-axis dimension) of center shank **20** in its region proximate to the attachment point of the enlarged element. It is also believed that the width (defined below as the x-axis dimension) of any vertically raised element of a conventional tool has not exceeded the height, or y-axis, of center shank **20** in the region of center shank **20** proximate to where the raised element is attached. Lastly, it is believed that in high-speed blending tools of the prior art that have raised elements, the z-axis dimension, or depth, of the raised element greatly exceeds its width, or x-axis, dimension. For clarification, the height, or y-axis, dimension of a blending tool and its elements shall mean the dimension of the tool or element in the plane that contains shaft **14** around which the tool rotates. The depth, or z-axis, of the tool and its elements shall mean the dimension perpendicular both to the axis of the tool's center shank and to the y-axis. The x-axis of the tool and its elements shall be measured in the direction of the axis of the tool's center shank. For center shank **20** itself, the x-axis dimension is a measure of its length. For any raised collision surface, the x-axis is a measure of its width.

Another characteristic of blending tools of the prior art is derived from the above limitations upon the height of the collision surface. Specifically, as explained above, conventional tools are thin in height and, if a vertical surface such as **19** is present, such vertical surface is also has a thin x-axis profile. Such thinness is required in order to avoid excessive vortices and low density regions in the lee of the tool. The trailing edges of conventional tools are sometimes rounded or arcuately shaped. However, because of the "thinness" of the tool in the y-axis, it is not necessary and it is not known to arcuately shape the leading or trailing surfaces of the tool except in the region proximate to the leading and/or trailing edge.

As noted above, different mixture formulations or products often specify different collision surface shapes and dimensions in order to optimize blend efficiency, blend time, and power consumption. For instance, if a fast blend process time is desired, then the blend tool can be rotated faster or a tool with a larger collision surface can be selected in order to increase the number of particle collisions per unit of time, or blending intensity. However, for any given viscosity, the power and configuration of the blending motor effectively limits the speed of the tool and the size of a collision surface such as surface **19**.

When the same blending vessel is used for different formulations or products requiring different tools, then procedures for changing a conventional blending tool require the following steps (described in relation to FIG. **1**) (A) lid **17** is unfastened and opened from the top of vessel **10**; (B) vessel **10** and tool **16** need to be at least partially cleaned by vacuum and by wiping, especially in the region where blending tool **16** is secured to shaft **14**; (C) locking fixture **17** is loosened to allow unfastening of tool **16** from shaft **14**; (D) blending tool **16** is detached from the locking fixture **17**;

(D) blending tool **16** is lifted from vessel **10** with care not to bump or scratch the sides of vessel **10**; (F) removed tool **16** is thoroughly cleaned before further handling and/or storage; and (G) the preceding tasks (except cleaning) are repeated in reverse order for attachment of a different blending tool **16**. For large blender vessels that are common in many if not most industrial applications, the weight of blending tool **16** requires a crane or hoist during unfastening, lifting, positioning of the replacement tool, and refastening. A human operator inside vessel **10** typically needs to help maneuver the crane or hoist during this process, and the combination of positioning a large tool while simultaneously attempting to fasten it onto shaft **14** can place the human operator in an awkward position. Even for smaller blenders, replacement of the tool requires fairly careful cleaning of shaft **14** and tool **16** and often requires an awkward manipulation while simultaneously positioning and fastening replacement tool **16**.

In addition to changing a blending tool to accommodate the requirements of different formulations or products, blending tools may require changing when excessively worn. Many industrial applications require blending of abrasive particles such as pigments, colorants (including carbon black), and electrophotographic toners. The above procedures for changing a tool must be used whenever a worn tool requires replacement.

The relevance of the above description of blending tool **16** to the manufacture of electrophotographic, electrostatic or similar toners is demonstrated by the following description of a typical toner manufacturing process. A typical polymer based toner is produced by melt-mixing the heated polymer resin with a pigment in an extruder, such as a Weiner Pfeider ZSK-53, whereby the pigment is dispersed in the polymer. After the resin has been extruded, the resin mixture is reduced in size by any suitable method including those known in the art. Such reduction is aided by the brittleness of most toners which causes the resin to fracture when impacted. This allows rapid particle size reduction in pulverizers or attritors such as media mills, jet mills, hammer mills, or similar devices. An example of a suitable hammer mill is an Alpine RTM Hammer Mill. Such a hammer mill is capable of reducing typical toner particles to a size of about 10 microns to about 30 microns. For color toners, toner particle sizes may average within an even smaller range of 4–10 microns.

After reduction of particle size by grinding or pulverizing, a classification process sorts the particles according to size. Particles classified as too large are typically fed back into the grinder or pulverizer for further reduction. Particles within the accepted range are passed onto the next toner manufacturing process.

After classification, the next typical process is a high speed blending process wherein surface additive particles are mixed with the classified toner particles within a high speed blender. These additives include but are not limited to stabilizers, waxes, flow agents, other toners and charge control additives. Specific additives suitable for use in toners include fumed silica, silicon derivatives such as Aerosil.RTM. R972, available from Degussa, Inc., ferric oxide, hydroxy terminated polyethylenes such as Unilin RTM., polyolefin waxes, which preferably are low molecular weight materials, including those with a molecular weight of from about 1,000 to about 20,000, and including polyethylenes and polypropylenes, polymethylmethacrylate, zinc stearate, chromium oxide, aluminum oxide, titanium oxide, stearic acid, and polyvinylidene fluorides such as Kynar. In aggregate these additives are typically present in

amounts of from about 0.1 to about 1 percent by weight of toner particles. More specifically, zinc stearate shall preferably be present in an amount of from about 0.4 to about 0.6 weight percent. Similar amounts of Aerosi.RTM. is preferred. For proper attachment and functionality, typical additive particle sizes range from 5 nanometers to 50 nanometers. Some newer toners require a greater number of additive particles than prior toners as well as a greater proportion of additives in the 25–50 nanometer range. When combined with smaller toner particle sizes required by color toners, the increased size and coverage of additive particles for some color toners creates increased need for high intensity blending.

The above additives are typically added to the pulverized toner particles in a high speed blender such as a Henschel Blender FM-10, 75 or 600 blender. The high intensity blending serves to break additive agglomerates into the appropriate nanometer size, evenly distribute the smallest possible additive particles within the toner batch, and attach the smaller additive particles to toner particles. Each of these processes occurs concurrently within the blender. Additive particles become attached to the surface of the pulverized toner particles during collisions between particles and between particles and the blending tool as it rotates. It is believed that such attachment between toner particles and surface additives occurs due to both mechanical impaction and electrostatic attractions. The amount of such attachments is proportional to the intensity level of blending which, in turn, is a function of both the speed and shape (particularly size) of the blending tool. The amount of time used for the blending process plus the intensity determines how much energy is applied during the blending process. For this purpose, “intensity” means the number of particle collisions per unit of time. For an efficient blending tool that avoids snow plowing and excessive vortices and low density regions, “intensity” can be effectively measured by reference to the power per unit mass (typically expressed as W/lb) of the blending motor driving the blending tool. Using a standard Henschel Blender tool to manufacture conventional toners, the blending times typically range from one (1) minute to twenty (20) minutes per typical batch of 60–1000 kilograms. For certain more recent toners such as toners for Xerox Docucenter 265 and related multifunctional printers, blending speed and times are increased in order to assure that multiple layers of surface additives become attached to the toner particles. Additionally, for those toners that require a greater proportion of additive particles in excess of 25 nanometers, more blending speed and time is required to force the larger additives into the base resin particles.

The process of manufacturing toners is completed by a screening process to remove toner agglomerates and other large debris. Such screening operation may typically be performed using a Sweco Turbo screen set to 37 to 105 micron openings.

The above description of a process to manufacture an electrophotographic toner may be varied depending upon the requirements of particular toners. In particular, for full process color printing, colorants typically comprise yellow, cyan, magenta, and black colorants added to separate dispersions for each color toner. Colored toner typically comprises much smaller particle size than black toner, in the order of 4–10 microns. The smaller particle size makes the manufacturing of the toner more difficult with regard to material handling, classification and blending.

The above general description of a process for making electrophotographic toners is well known in the art. More information concerning methods and apparatus for manu-

facture of toner are available in the following U.S. patents, and each of the disclosures of which are incorporated herein: U.S. Pat. No. 4,338,380 issued to Erickson, et al; U.S. Pat. No. 4,298,672 issued to Chin; U.S. Pat. No. 3,944,493 issued to Jadwin, et al; U.S. Pat. No. 4,007,293 issued to Mincer, et al; U.S. Pat. No. 4,054,465 issued to Ziobrowski; U.S. Pat. No. 4,079,014 issued to Burness, et al; U.S. Pat. No. 4,394,430 issued to Jadwin, et al; U.S. Pat. No. 4,433,040 issued to Niimura, et al; U.S. Pat. No. 4,845,003 issued to Kiriu, et al; U.S. Pat. No. 4,894,308 issued to Mahabadi et al.; U.S. Pat. No. 4,937,157 issued to Haack, et al; U.S. Pat. No. 4,937,439 issued to Chang et al.; U.S. Pat. No. 5,370,962 issued to Anderson, et al; U.S. Pat. No. 5,624,079 issued to Higuchi et al.; U.S. Pat. No. 5,716,751 issued to Bertrand et al.; U.S. Pat. No. 5,763,132 issued to Ott et al.; U.S. Pat. No. 5,874,034 issued to Proper et al.; and U.S. Pat. No. 5,998,079 issued to Tompson et al.

As described above, the process of blending plays an increasingly important role in the manufacture of electrophotographic and similar toners. It would be advantageous if an apparatus and method were found to accelerate the blending process and to thereby diminish the time and cost required for blending. Similarly, since different formulations and products often require different blending speed and intensities, it would be advantageous if an apparatus and method were found to allow a single blending tool to be reconfigured in situ for various blending intensities rather than requiring cleaning, removal, and replacement of the entire blending tool for each required change in intensity.

#### SUMMARY OF THE INVENTION

One aspect of the present invention is an improved blending tool for rotation in a blending machine, said tool comprising a center shank having an end and a region proximate to the end; an enlarged collision element rigidly fixed during rotation of the tool to the center shank at the end region; and a trailing surface of the enlarged collision element, at least half of said trailing surface being negatively sloped

Another aspect of the present invention a blending machine, comprising a vessel for holding the media to be blended; a blending tool mounted inside the vessel, said blending tool comprising a center shank having an end and a region proximate to the end; an enlarged collision element rigidly fixed during rotation of the tool to the center shank at the end region; and a trailing surface of the enlarged collision element, at least half of said trailing surface being negatively sloped; and a rotatable drive shaft, connected to the blending tool inside of the vessel, for transmitting rotational motion to the blending tool.

Yet another aspect of the present invention is a method of making toners, comprising melt-mixing a mixture containing toner resin and colorants; reducing the melt-mixture into particles; adding surface additive particles to the mixture of melt-mixture particles; and blending the melt-mixture particles and surface additive particles in a blending machine using a rotating blending tool comprising a center shank having an end and a region proximate to the end; an enlarged collision element rigidly fixed during rotation of the tool to the center shank at the end region; and a trailing surface of the enlarged collision element, at least half of said trailing surface being negatively sloped.

#### BRIEF DESCRIPTION OF THE DRAWINGS

Other aspects of the present invention will become apparent as the following description proceeds and upon reference to the drawings, in which:

FIG. 1 is a schematic elevational view of a blending machine of the prior art;

FIG. 2 is a perspective view of a blending tool of the prior art;

FIG. 3 is a perspective view of an embodiment of the blending tool of the present invention;

FIG. 4 is a perspective view of an embodiment of the blending tool of the present invention having an adjustable articulator hinge;

FIG. 5 is a perspective view of an embodiment of an articulator hinge of the present invention; and

FIG. 6 is a chart showing specific power levels of the blending motor when using different configurations of the blending tool of the present invention and when using a conventional tool of the prior art.

#### DETAILED DESCRIPTION OF THE DRAWINGS

While the present invention will hereinafter be described in connection with its preferred embodiments and methods of use, it will be understood that it is not intended to limit the invention to these embodiments and method of use. On the contrary, the following description is intended to cover all alternatives, modifications, and equivalents, as may be included within the spirit and scope of the invention as defined by the appended claims.

One aspect of the present invention is creation of a blending tool capable of generating more intensity (collisions/unit of time) than heretofore possible. This increased intensity is the result of an enlarged collision surface employing an aerodynamic-like shape that enables enlargement of the collision profile while minimizing vortices and particle voids in the zone behind the rotating blending tool. The combination of a larger collision profile and minimization of voids and vortices behind the tool result in more collisions per unit of time, or intensity. Such increase of intensity allows blending time to be decreased, thereby saving batch costs and increasing productivity.

Accordingly, a blending tool **50** of the present invention is shown in FIG. 3 inside of a vessel **10** that is similar to that shown in FIG. 1. Center shank **51** contains locking fixture **52** at its middle for mounting onto rotating drive shaft **14** (not shown) of the blending machine **2** (not shown). As shown in FIG. 3, an enlarged collision element comprises collision anvil **55** that is proportionately larger than the collision surface of blending tools of the prior art such as that shown in FIG. 2. In conventional tools, as discussed above, enlarged collision surfaces are not practical because a large collision surface creates too much “snow plow” compaction in front of the tool and vortices and relative voids in the wake of the tool. To overcome these impediments, a novel feature of the present invention is an enlarged collision element such as collision anvil **55** with cross-sectional perimeters of its leeward surfaces that decrease as such cross-sections are measured closer to the trailing edge of the tool, i.e., its sides and/or top and bottom surfaces tend towards convergence toward the trailing edge. This “negative slope” of the leeward surface increases intensity since particles that are pushed upward or sideways upon contact with the collision anvil slide along the leeward slope of the tool to fill its wake as the tool slides through the particle mixture. Although the actual movements of particles within a blending machine requires complex 3-dimensional analysis, it is believed that an accurate shape best accomplishes the above design since it causes collision anvil **55** to function much like an air foil in a gas fluid. In other words, the particle media through which the blending tool moves

acts like a fluid as it is mixed by the tool. As with an air foil, the sloping leeward shape helps minimize voids and turbulence behind the tool. The result is greater particle density available for collision by the next arm of the tool as it sweeps through the blending zone. Greater density of particles leads to greater intensity (collisions/unit of time). Additionally, as noted above, the rounded shape of the leading profile of collision anvil **55** results in more flow of particles over the tool and less “snow plow” compaction in front of the tool. The result is that for the same consumption of power by the blending machine, it is believed that the present invention allows either greater tool speed or a larger collision plate profile. Either greater speed or larger profile result in greater blend intensity.

For clarity, the portion of collision anvil **55** that adds to the profile of the tool can be considered its “leading surface” and is labeled **57** in FIG. 3. This is the surface that most directly impacts the particle media. The portion of collision anvil **55** to the rear of the leading surface can be considered its “trailing surface” and is labeled **56** in FIG. 3. Using the accurately shaped trailing surface of the present invention, it is possible to increase the height, or y-axis dimension, of the collision anvil to exceed (even by a factor greater than 2 or 3) the depth, or z-axis dimension, of center shank **51** in the region proximate to where collision anvil **55** is attached. It is also possible to increase the width, or x-axis dimension, of collision anvil **55** to a width that exceeds (even by a factor greater than 1.5 or 2) the height, or y-axis, of center shank **51** in the region of center shank **51** proximate to where collision plate **35** is attached. For a large collision anvil **55**, it is preferred that collision anvil **55** be hollow or comprised of a relatively thin plate in order to reduce its weight. Specifically, it is preferable that the leading surface of collision anvil **55** or other enlarged collision element of the present invention be less than one-half inch thick and preferably as thin as  $\frac{3}{16}$  inch thick.

It should be recognized that application of the above design principles enables any number of designs, including the design discussed below relating to use of adjustable and spaced apart collision plates. Although the preferred embodiment of this aspect of the invention comprises an accurate shape over the entire trailing and leading surfaces, it may be possible to achieve an acceptable result using a negative slope over less than all (perhaps approximately one-half) of the entire trailing surface. It also preferred that most or all of the leading surface have an accurate shape. The larger the profile of the collision surface, the larger the proportion of the trailing surface that must be negatively sloped in order to achieve the effects of the present invention.

Yet another aspect of the present invention is a blending tool that allows reconfiguration of the effective collision surface size and profile without removal of the entire tool. Referring to FIG. 4, blending tool **30** comprises a center shank **31** and collision plates **35A** and **35B**. Center shank **31** contains locking fixture **32** at its middle for mounting onto rotating drive shaft **14** (not shown) of the blending machine **2** (not shown). Each end of center shank **31** contains a connecting mechanism **33** for rigidly mounting and holding an arm shown, respectively, as **34A** and **34B**. Connecting mechanism **33** shown in FIG. 4 comprises a simple nut and bolt fastener which compresses together and rigidly positions collision plates **35A** and **35B** on arms **34A** and **34B** and on center shank **31**, respectively. As will be described more fully below, below, different arrangements for positioning arms **34A** and **34B** are possible. Additionally, different arrangements for an adjustable collision surface are pos-

sible. For instance, each end region of the center shank **31** could comprise a leading edge flap connected to the center shank by one, two, or more connector mechanisms such that the angle of the flaps could be tilted down or raised much like the leading edge slat of some high speed jets and airplanes

In the embodiment shown, mounted at the opposite end of arm **34A** from mechanism **33** is an enlarged collision surface formed out of a collision plate **35A**. Collision plate **35A** differs from collision surfaces of the prior art since collision plate **35A** is spaced apart and not integrally forged, welded, or otherwise formed as part of center shank **31**. Additionally, collision plate **35A** presents a substantially larger profile than the profile of center shank **31**. Different arrangements for locking collision plate **35A** into position are possible. For instance, collision plate **35A** could be directly connected to center shank **31** without an arm **34A** therebetween or arm **34A** could be permanently attached to center shank **31** with a connecting mechanism between the arm **34A** and collision plate **35A**. Arm **34A** can assume any number of embodiments, including compound elements, as long as arm **34A** functions to position the collision plate apart from center shank **31**. A preferred embodiment of the present invention uses a connecting mechanism such as mechanism **33** that enables removal and replacement of a collision plate when the collision plate reaches the end of its useful life due to abrasion and wear. Without such removable collision plates, the entire blending tool requires disposal or remanufacturing when the collision plate reaches the end of its useful life.

Connecting mechanism **33** can assume any number of arrangements long as it allows adjustment of the profile of the tool. In the embodiment shown, mechanism **33** allows arm **34A** to pivot about the axis of center shank **31**. In effect, mechanism **33** forms an articulator hinge that allows arm **34A** to assume any number of angles in relation to center shank **31**. This articulator hinge is a simple bolt and nut fastener that can be loosened and tightened with standard tools such as socket wrenches. Any number of other articulator hinges are possible as long as they allow arm **34A** to pivot when the hinge is loosened and to be held rigidly in place once the hinge is tightened.

An example of an alternate embodiment of an articulator hinge **33** is shown in FIG. **5**. The embodiment shown in FIG. **5** allows articulation of arm **34** into pre-set positions determined by alignment of bolt **45** (which runs through a hole in arm **34**) with bored holes **41**, **42**, **43**, and **44** formed in central hub **35**. The process of articulating the hinge to these pre-set angles is accomplished by the relatively easy loosening and withdrawal bolt **45**. As bolt **45** becomes withdrawn, arm **34** can be repositioned such that bolt **45** aligns with and can be inserted into one of alternate holes **41**, **42**, **43**, and **44**. Lastly, arm **34** is again secured in place by refastening bolt **45**.

It should be recognized that many alternate designs for reconfigurable tools are possible. For instance, the above description of a leading edge flap could accomplish this purpose. Similarly, a movable collision surface, preferably a collision plate, could be connected directly to the center shank without an arm to provide spaced apart separation between the surface and the center shank. Although many such variations are possible, however, the preferred embodiment comprises an arm and a spaced apart collision plate as described above in relation to FIGS. **3** and **4**.

The advantages of the reconfigurable blending tool of the present invention is made clear when the adjustment proce-

dures are compared to the procedures necessary to change-out the non-adjustable tooling of the prior art. The conventional procedures are described above and require, among other steps, cleaning of the blending vessel and tool to gain access to the lock mechanism of the drive shaft of the blending machine followed by typical use of a crane or hoist to lift the tool out of the vessel. In contrast, the comparable process for altering the configuration of the blending tool of the present invention is as follows (numbers are in reference to FIG. **1** and FIG. **3**, as applicable): (A) lid **17** is unfastened and opened from the top of vessel **10**; (B) blending tool **16** needs to be at least partially cleaned by vacuum and by wiping in the region of articulator hinge **33**; (C) articulator hinge **33** is loosened to allow arm **34** (and therefore collision plate **35**) to be repositioned; (D) arm **34** is repositioned to the new angle required by the next formulation or product; (E) articulator hinge **33** is re-tightened.

In sum, blending tool **16** of the present invention with its articulator hinge enables significant time, safety, and productivity savings. Among the advantages are: 1) elimination of the need for a crane or hoist, thereby saving time (especially if such crane or hoist is not immediately available) as well as a requirement for expensive supplementary equipment such as a hoist; 2) human operators do not need to simultaneously position and fasten during removal of the old tools and placement of the new tool; and 3) cleaning tasks are greatly curtailed and simplified since the entire tool need not be cleaned for replacement, handling, or storage. Cleaning of vessel **10** is also lessened and shaft **14** need not be cleaned at all. Lastly, it is obviously less expensive to be able to use a single flexible blending tool for various formulations and products than to require an inventory of tools which must be substituted each time a formulation or product requires a different tool configuration.

The flexibility of the blending tool of the present invention is demonstrated in FIG. **6**, which shows the various levels of intensity that were obtained with the tool of the present invention as it is reconfigured into different positions. Each of the 4 curves shown on FIG. **6** show data created during blending of Xerox toner for a Xerox Docucenter 265 multifunctional printer in a Henschel 75-liter blender. Four blends were made, all using the same tool speed. The vertical axis measures the specific power of the blending motor (W/lb) which, as discussed above, is considered a good measure of the blend intensity when using an efficient blending tool. The horizontal axis measures time of the blend. The curve marked with round data points shows the results with arm **34** set at 45 degrees, which angle offered the greatest tool profile for this experiment. As can be seen in FIG. **6**, this curve with round data points, reflecting the largest profile, shows the greatest blend intensity. The curve marked with diamond data points shows the results with arm **34** set at 22.5 degrees, while the curve marked with triangular data points shows the results with arm **34** set at 0 degrees. These angles cause decreasing tool profiles and, as expected, decreasing blend intensity that reflects the decreased profiles. Lastly, the curve with square shaped data points shows the results using a standard Henschel blending tool typically used when blending electrophotographic toners (this tool differs from the tool in FIG. **2**). When compared to the results using the 45-degree arm position, the standard tool provided less than 50% of the blend intensity offered by the tool of the present invention at its maximum profile and intensity. Such results are to be expected since conventional tools lack both collision plates and accurate trailing surfaces.

Accordingly, the blending tool of the present invention includes a collision plate, accurate surfaces, and articulator

hinge. When compared to known blending tools in the prior art, the present invention permits higher blend intensity than heretofore possible without snow plow compaction in front of the tool or vortices and voids in the wake of the tool. Additionally, the articulator hinge of the present invention enable a single blending tool of the present invention to assume a wide variety of different configurations, each enabling a different level of blend intensity as may be required by different formulations and products. Together, these improvements of the present invention enable greater blend intensity and overall productivity as well as savings in tool and inventory cost, time, and safety. When the advantages are applied to the manufacture of toners, substantial cost savings result.

It is, therefore, evident that there has been provided in accordance with the present invention a blending tool that fully satisfies the aims and advantages set forth above. While the invention has been described in conjunction with several embodiments, it is evident that many alternatives, modifications, and variations will be apparent to those skilled in the art. Accordingly, it is intended to embrace all such alternatives, modifications, and variations as fall within the spirit and broad scope of the appended claims.

What is claimed is:

1. A method of making toners, comprising
  - (a) melt-mixing a mixture containing toner resin and colorants;
  - (b) reducing the melt-mixture into particles;
  - (c) adding surface additive particles to the mixture of melt-mixture particles; and
  - (d) blending the melt-mixture particles and surface additive particles in a blending machine using a rotating blending tool rotating in a plane, said rotating blending tool comprising a center shank having an end and a region proximate to the end; an enlarged collision element rigidly fixed during rotation of the tool to the center shank at the end region; a trailing surface of the enlarged collision element, said trailing surface having a height dimension measured along the direction perpendicular to the plane of rotation and a depth dimension measured along the plane of rotation wherein the height of the trailing surface along at least half of its depth dimension is convexly negatively sloped.
2. The method of claim 1, wherein the step of blending further comprises rotating at least a portion of the enlarged collision element of the blending tool at a speed greater than 50 ft./second.
3. The method of claim 1, wherein the step of blending further comprises rotating at least a portion of the enlarged collision element of the blending tool at a speed greater than 85 ft./second.
4. The method of claim 1, wherein the step of blending further comprises rotating at least a portion of the enlarged collision element of the blending tool at a speed greater than 90 feet/second.
5. The method of claim 1, wherein the step of blending further comprises rotating at least a portion of the enlarged collision element of the blending tool at a speed greater than 95 feet/second.
6. The method of claim 1 wherein the step of blending further comprises using a blending tool configuration generating in excess of 0.50 kW specific power in a 75-liter blending vessel.

7. The method of claim 1 wherein:

- a) the collision surface of the blending tool has a collision profile and is connected to the center shank by a connector mechanism capable of connecting the collision surface in different positions such that the collision profile varies with different positions of connection; and
- b) the step of blending further comprises adjusting the collision surface to a different position.

8. The method of claim 1, wherein the step of blending further comprises rotating at least a portion of the enlarged collision element of the blending tool at a speed greater than 50 ft./second.

9. The method of claim 1, wherein the step of blending further comprises rotating at least a portion of the enlarged collision element of the blending tool at a speed greater than 85 ft./second.

10. The method of claim 1, wherein the step of blending further comprises rotating at least a portion of the enlarged collision element of the blending tool at a speed greater than 90 feet/second.

11. The method of claim 1, wherein the step of blending further comprises rotating at least a portion of the enlarged collision element of the blending tool at a speed greater than 95 feet/second.

12. A method of making toners, comprising

- (a) melt-mixing a mixture including toner resin and colorants;
- (b) reducing the melt-mixture into particles;
- (c) adding surface additive particles to the mixture of melt-mixture particles;
- (d) blending the melt-mixture and surface additive particles in a blending machine using a rotating blending tool comprising a center shank, a collision surface having a collision profile, and a connector mechanism connecting the collision surface to the center shank, said connector mechanism capable of connecting the collision surface to the center shank in different positions such that the collision profile varies with different positions of connection.

13. The method of claim 12, further comprising adjusting the collision surface to a different position.

14. The method of claim 12, further comprising adjusting the collision profile of the blending tool by steps comprising:

- (a) loosening at least one connector mechanism;
- (b) moving the collision surface to a different position; and
- (c) retightening the connector mechanism while the collision surface is in the different position.

15. The method of claim 12, wherein the step of blending further comprises rotating the blending tool such that at least a portion of the collision surface has a velocity in excess of 50 ft./second.

16. The method of claim 12, wherein the step of blending further comprises rotating the blending tool such that at least a portion of the collision surface has a velocity in excess of 85 ft./second.

17. The method of claim 12, wherein the step of blending further comprises rotating the blending tool such that at least a portion of the collision surface has a velocity in excess of 95 feet/second.