



US006580607B1

(12) **United States Patent**  
**Feldmeyer**

(10) **Patent No.:** **US 6,580,607 B1**  
(45) **Date of Patent:** **Jun. 17, 2003**

(54) **ELECTRONIC COMPONENT MOUNTING ASSEMBLY AND PORTIONS THEREOF**

(75) Inventor: **Mark D. Feldmeyer**, San Jose, CA (US)

(73) Assignee: **Hewlett-Packard Development Company, L.P.**, Houston, TX (US)

(\*) Notice: Subject to any disclaimer, the term of this patent is extended or adjusted under 35 U.S.C. 154(b) by 0 days.

(21) Appl. No.: **10/052,161**

(22) Filed: **Jan. 16, 2002**

(51) Int. Cl.<sup>7</sup> ..... **G06F 1/16**

(52) U.S. Cl. .... **361/685; 361/747**

(58) Field of Search ..... **361/685, 801, 361/726, 732, 740, 741, 747, 756, 759, 800, 802; 312/223.1, 223.2; 211/41.17, 26.2**

(56) **References Cited**

**U.S. PATENT DOCUMENTS**

5,112,119 A	*	5/1992	Cooke et al. ....	312/283
5,587,889 A		12/1996	Sacherman .....	361/809
5,806,949 A		9/1998	Johnson .....	312/334.7
6,275,377 B1	*	8/2001	Liu et al. ....	361/685
6,330,147 B1	*	12/2001	Adams et al. ....	361/679
6,418,012 B1	*	7/2002	Dials et al. ....	361/685
6,469,889 B1	*	10/2002	Gan .....	361/685
6,473,300 B1	*	10/2002	Youngquist et al. ....	361/685

\* cited by examiner

*Primary Examiner*—David Martin

*Assistant Examiner*—Phuong T. Vu

(57) **ABSTRACT**

An electronic apparatus and portions thereof are disclosed including an electronic component; a rail member; and an elongated resilient member used to attach the rail member to the electronic component.

**29 Claims, 9 Drawing Sheets**

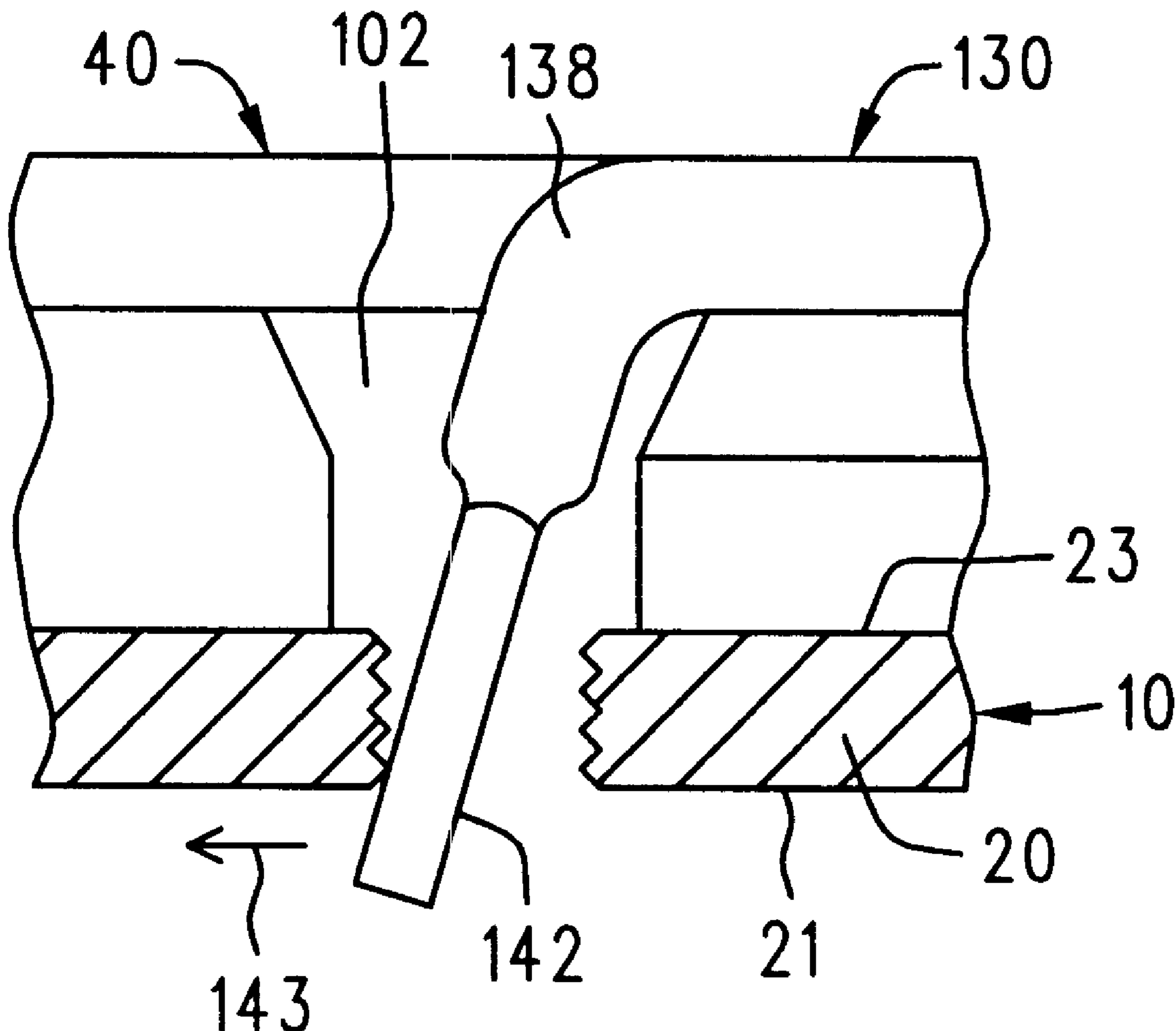

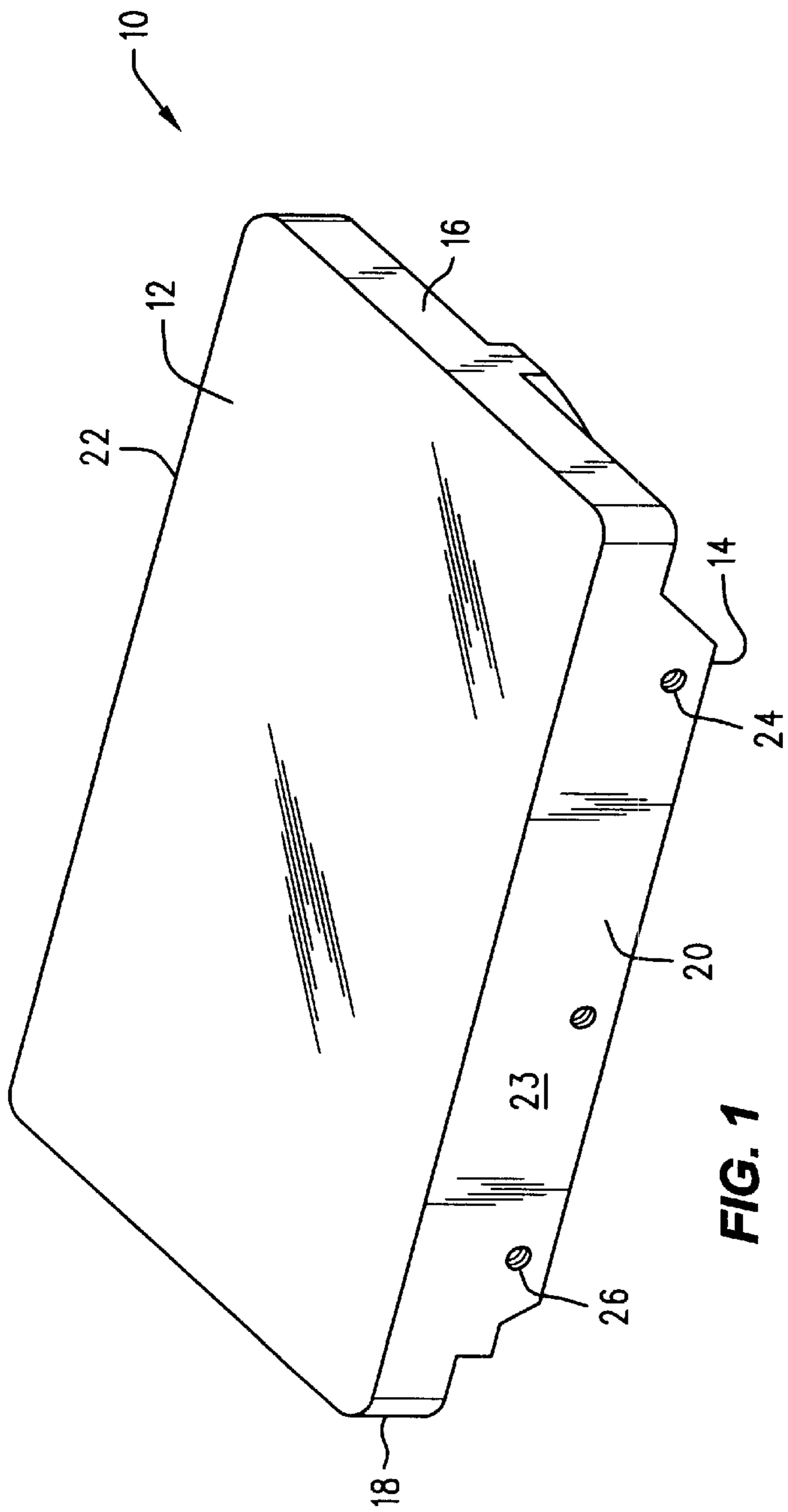

FIG. 1

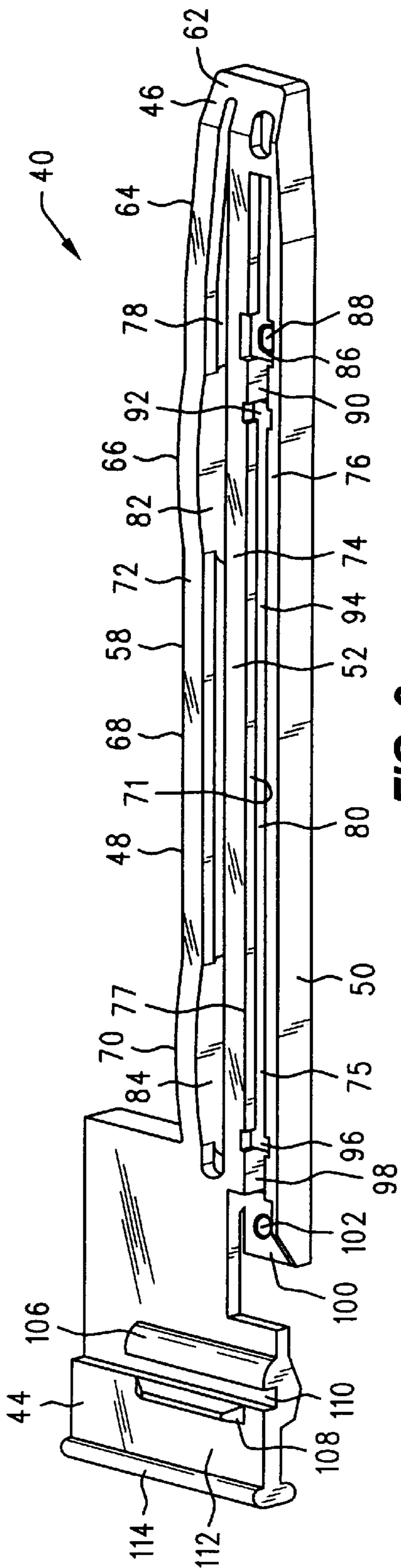

FIG. 2

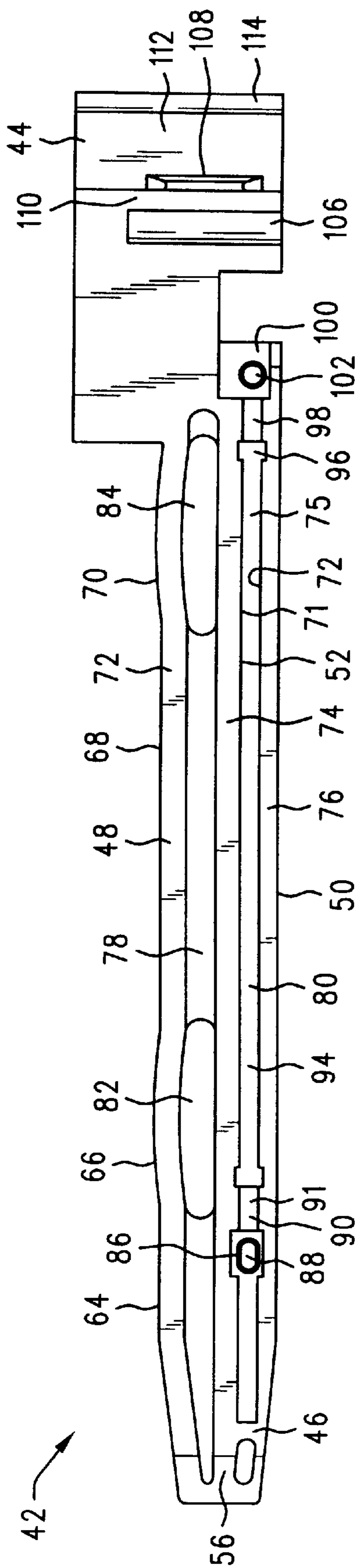

FIG. 3

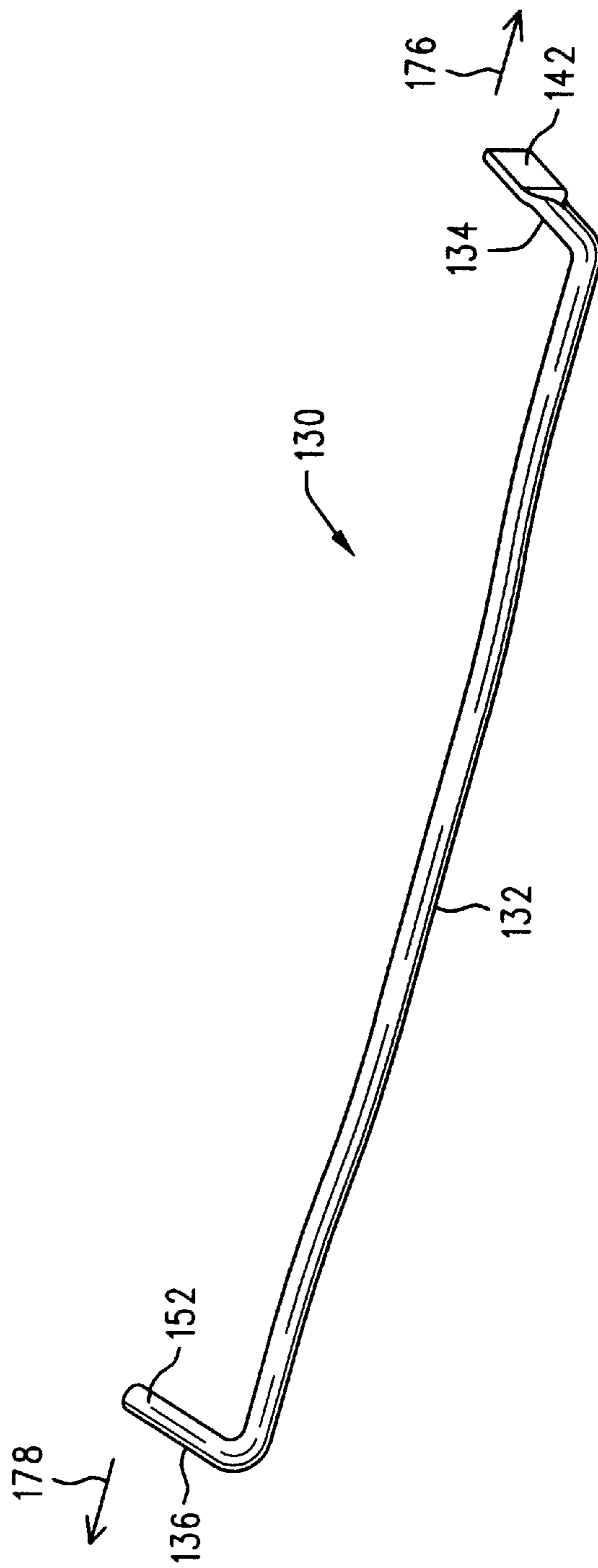
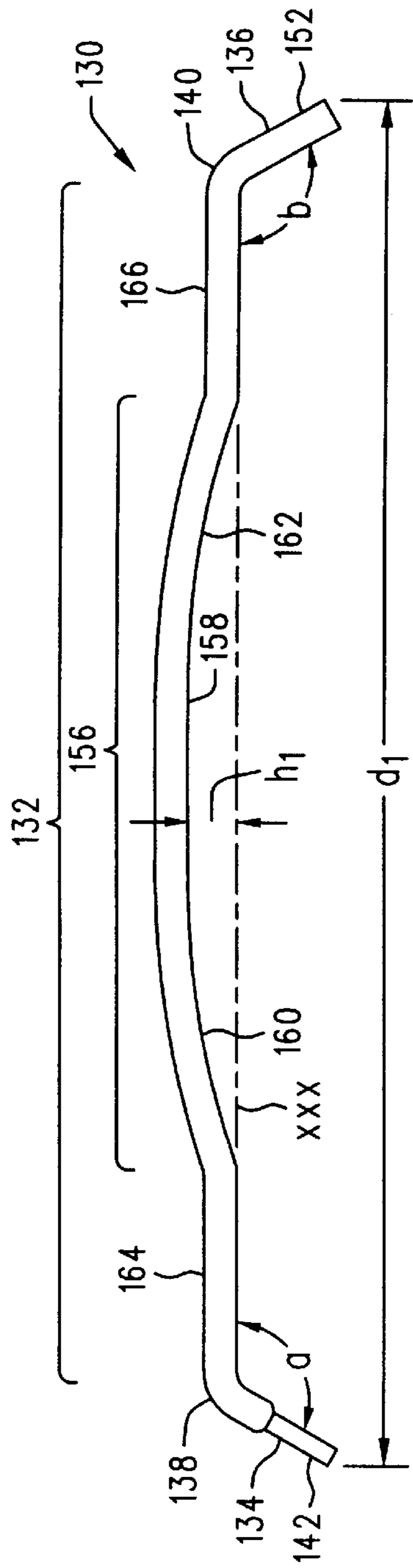
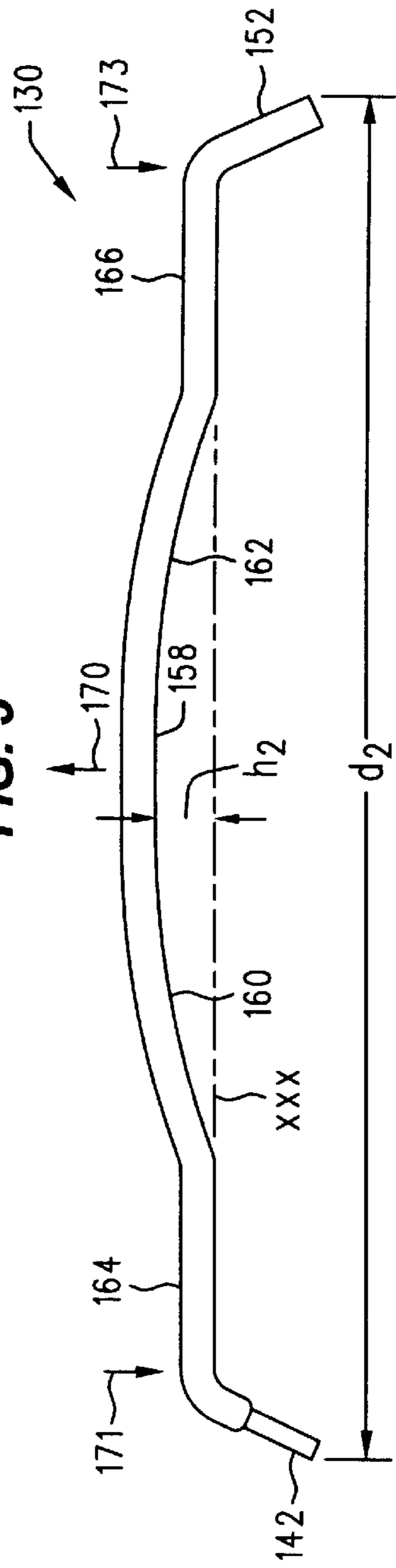

FIG. 4



**FIG. 5**



**FIG. 6**

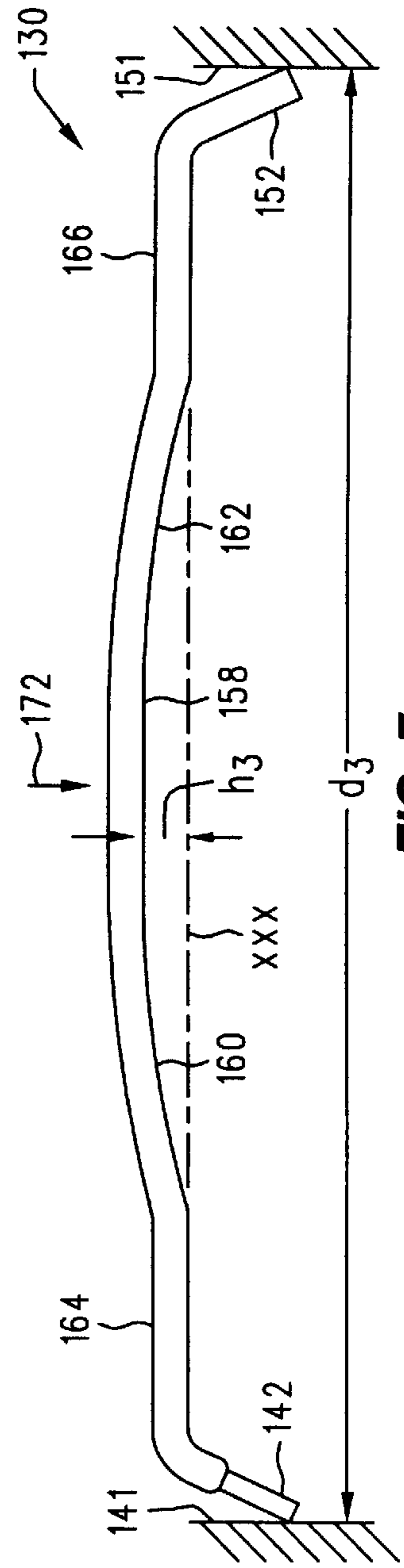

**FIG. 7**

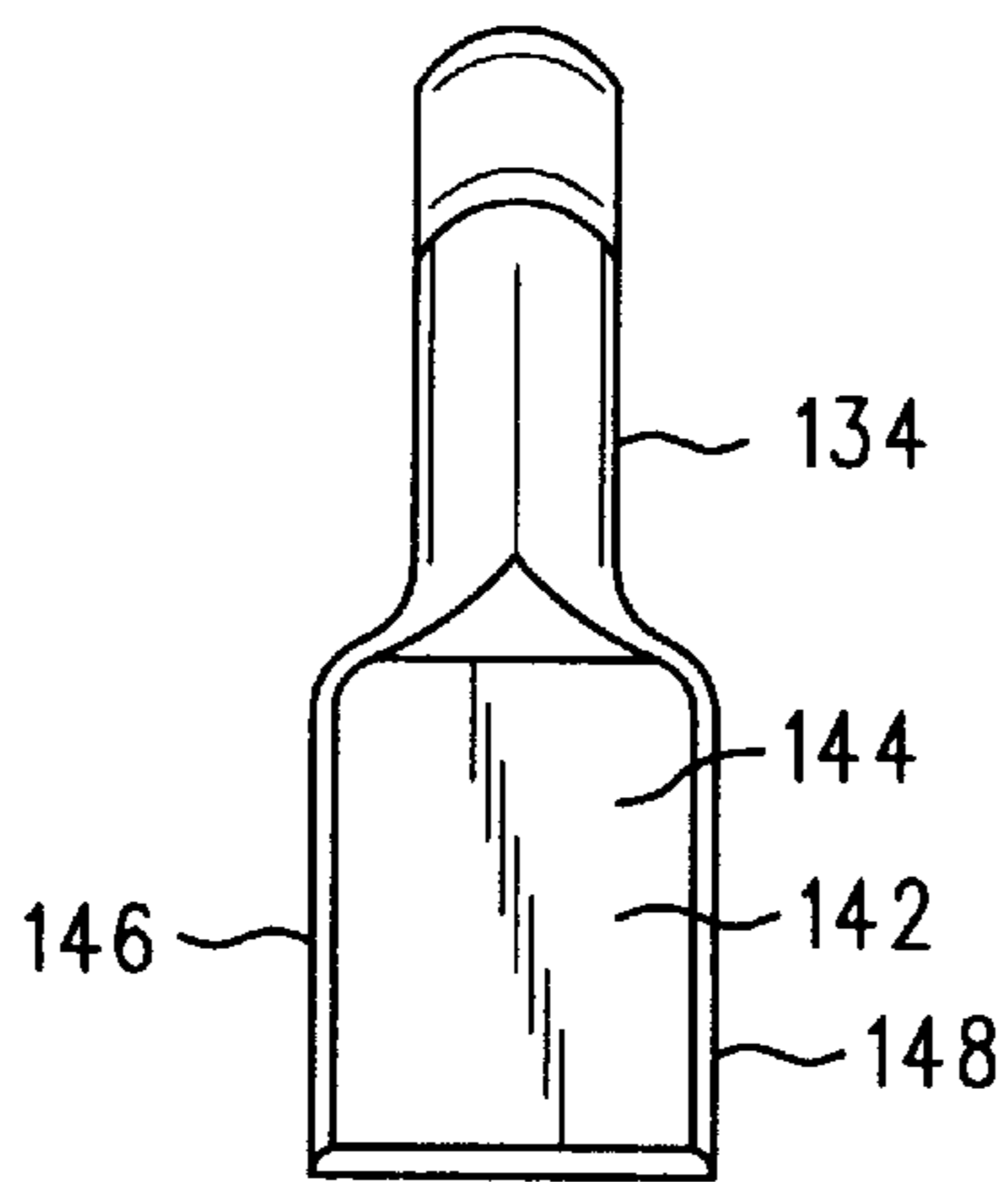

**FIG. 8**

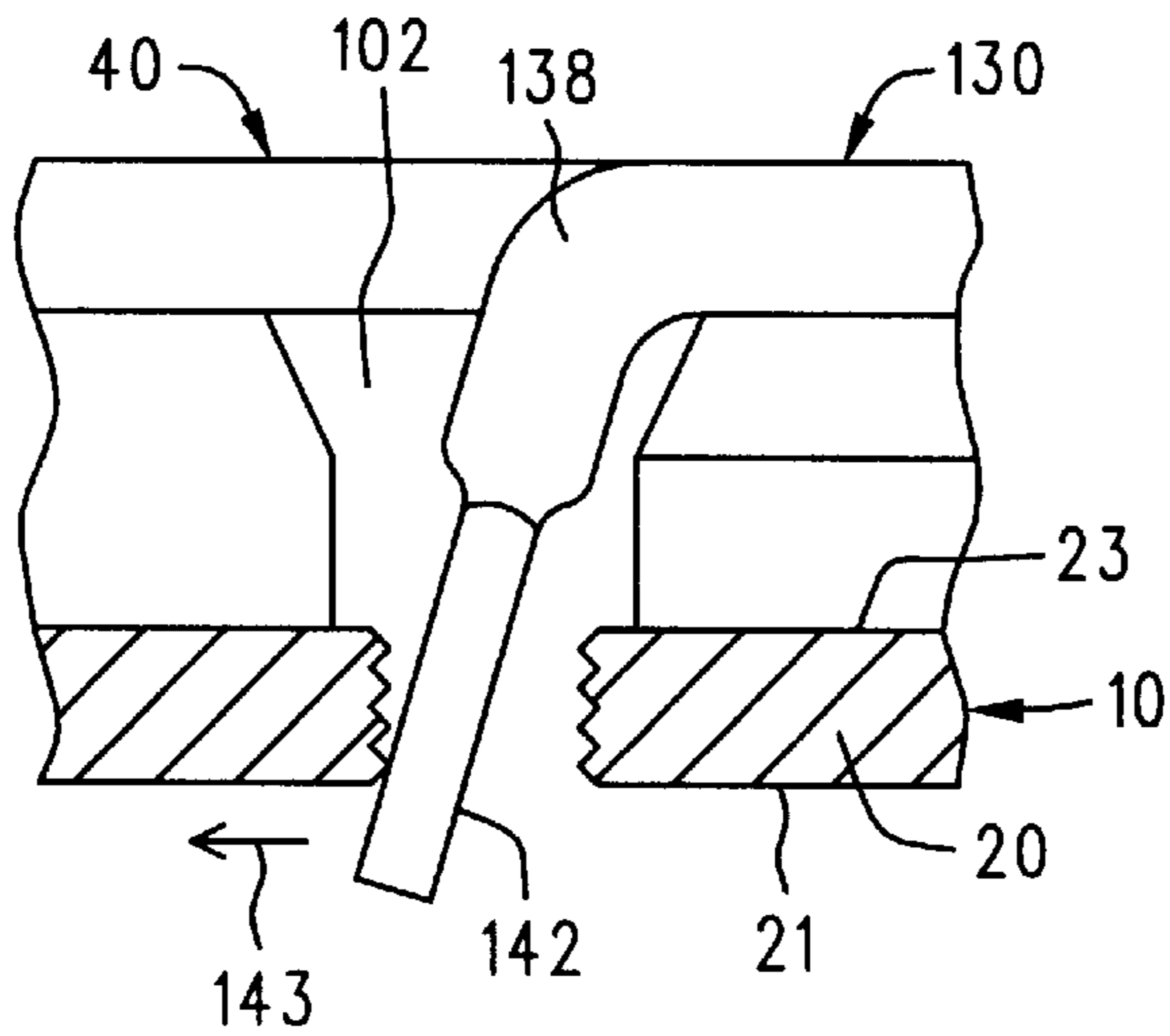

**FIG. 9**

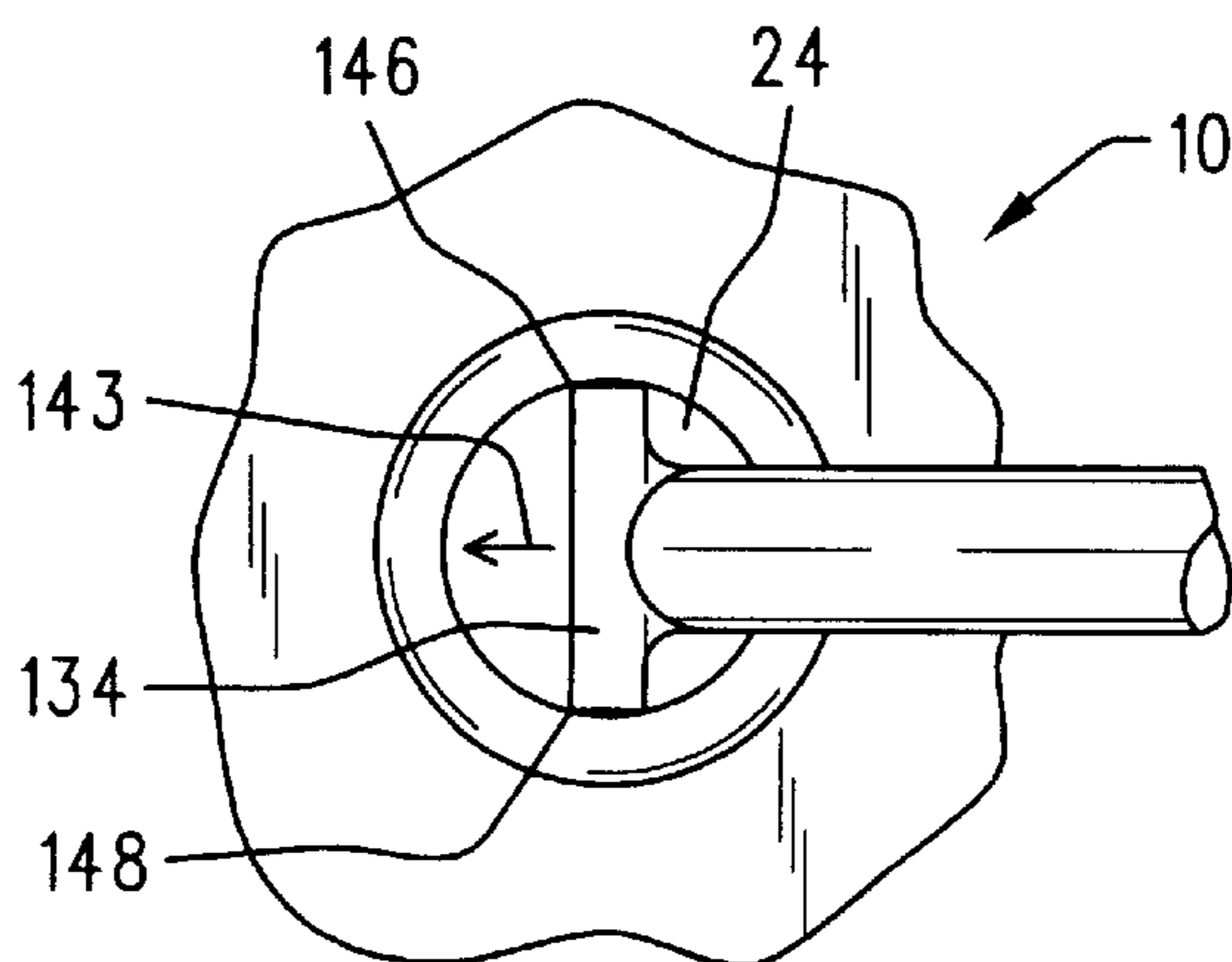

**FIG. 10**

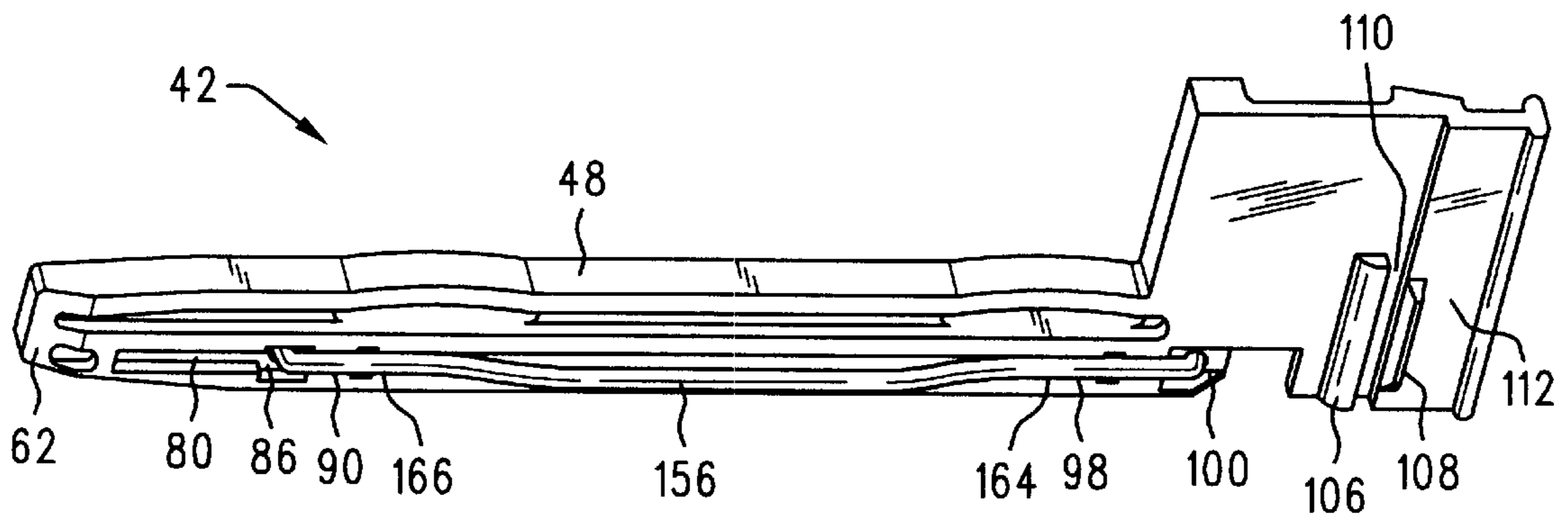

**FIG. 11**

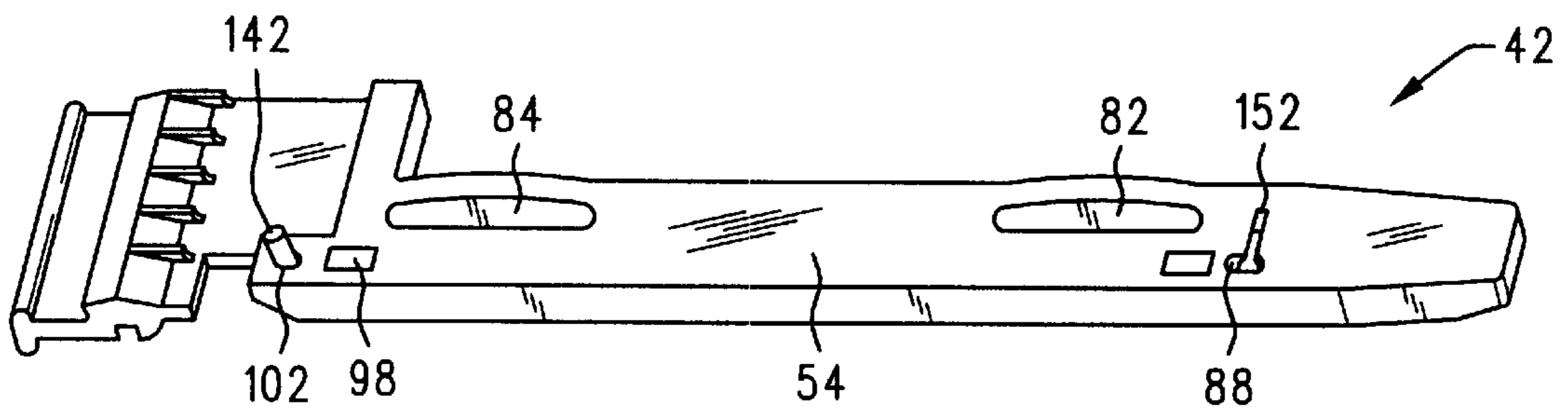

**FIG. 12**

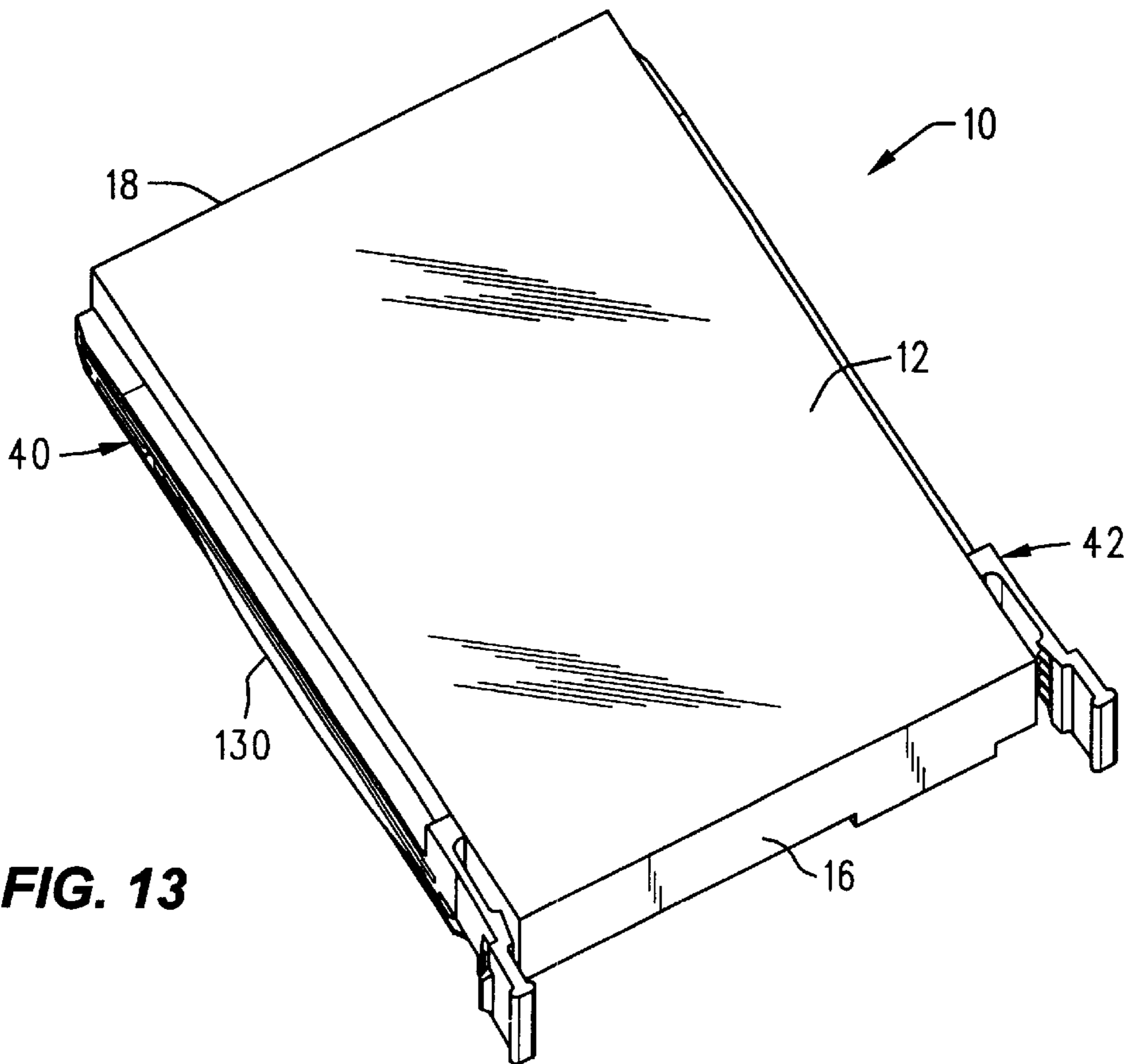

**FIG. 13**

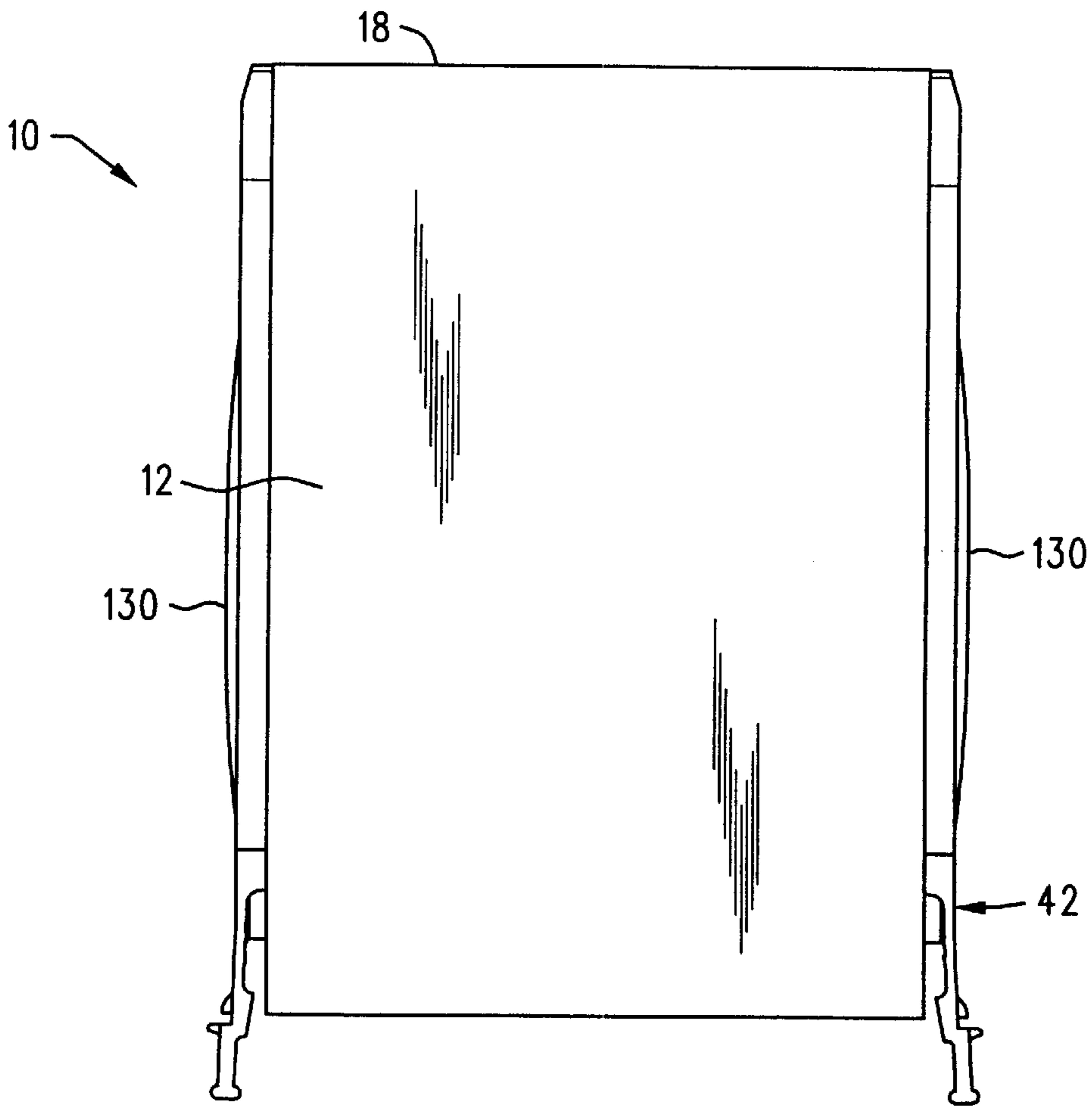

**FIG. 14**

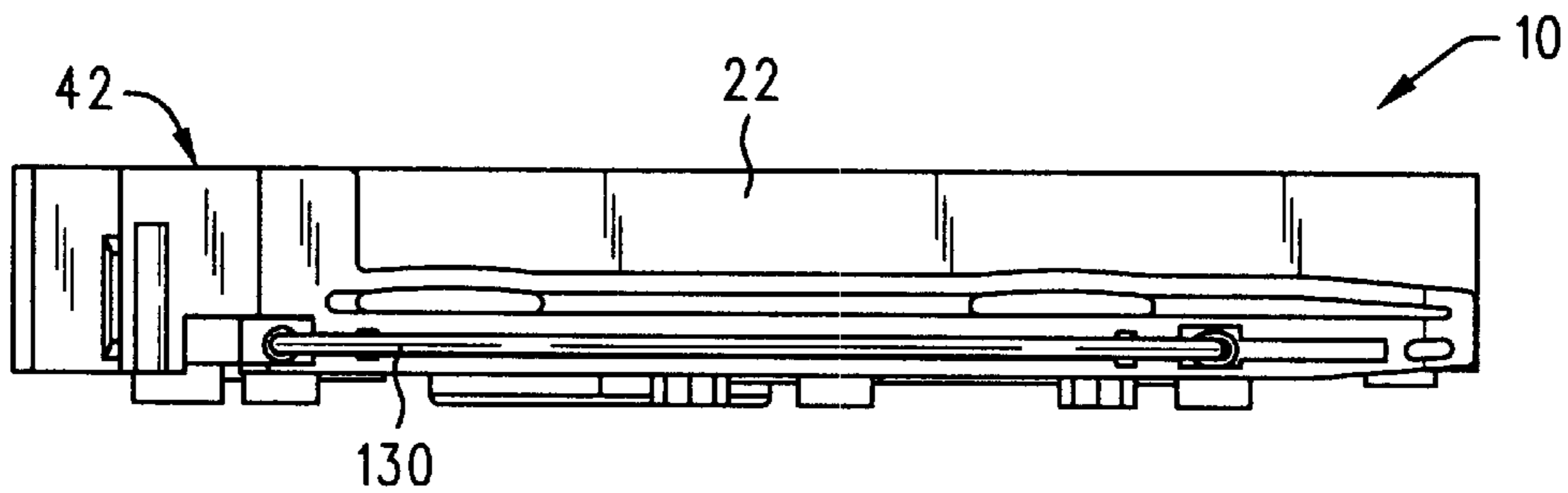

**FIG. 15**

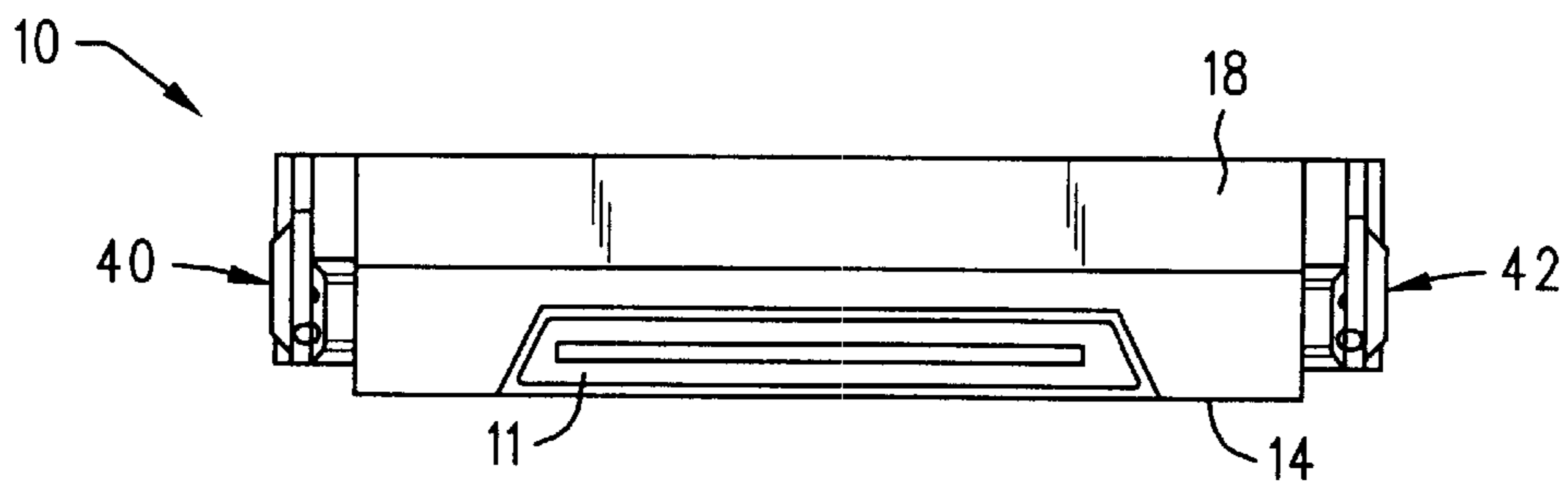

**FIG. 16**

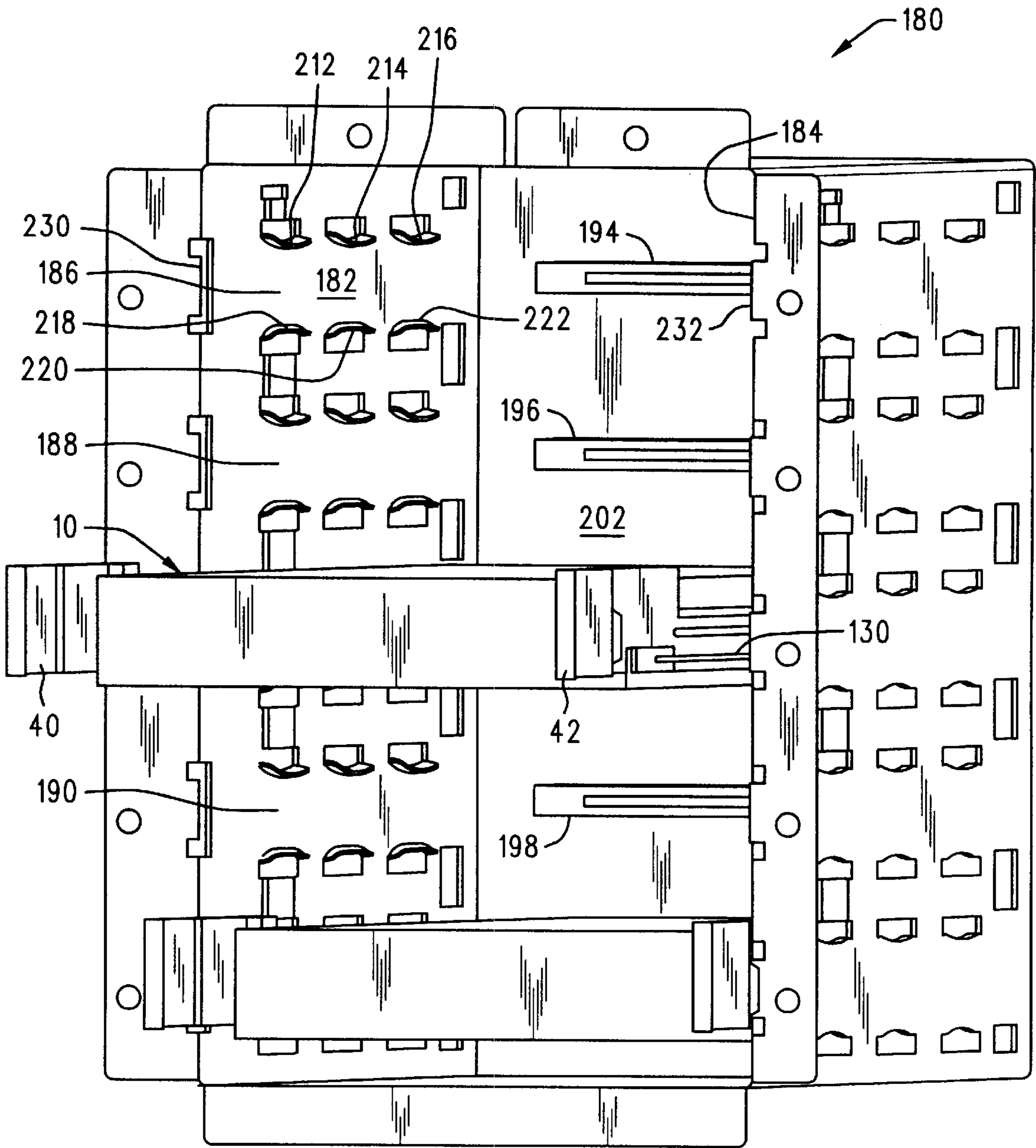
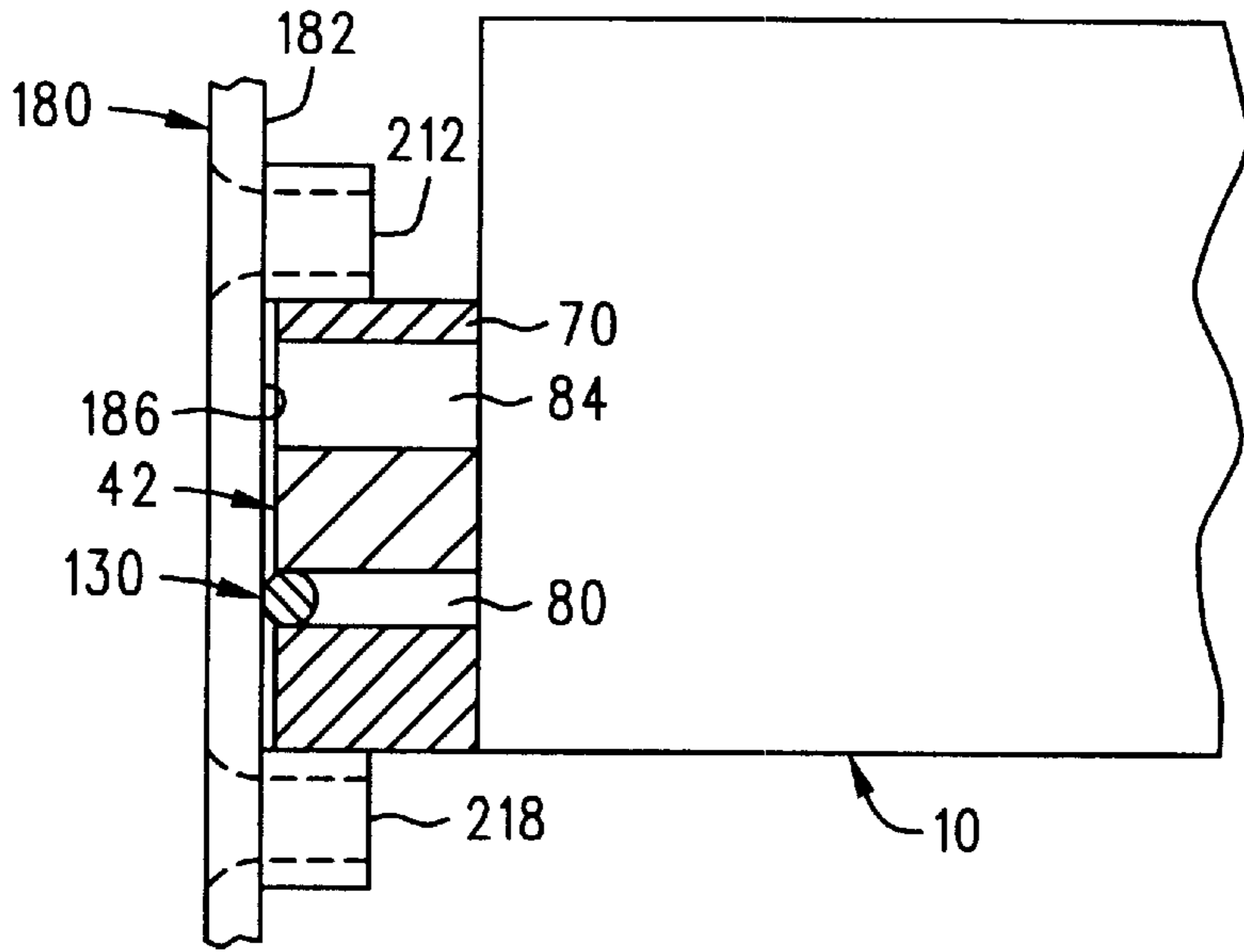
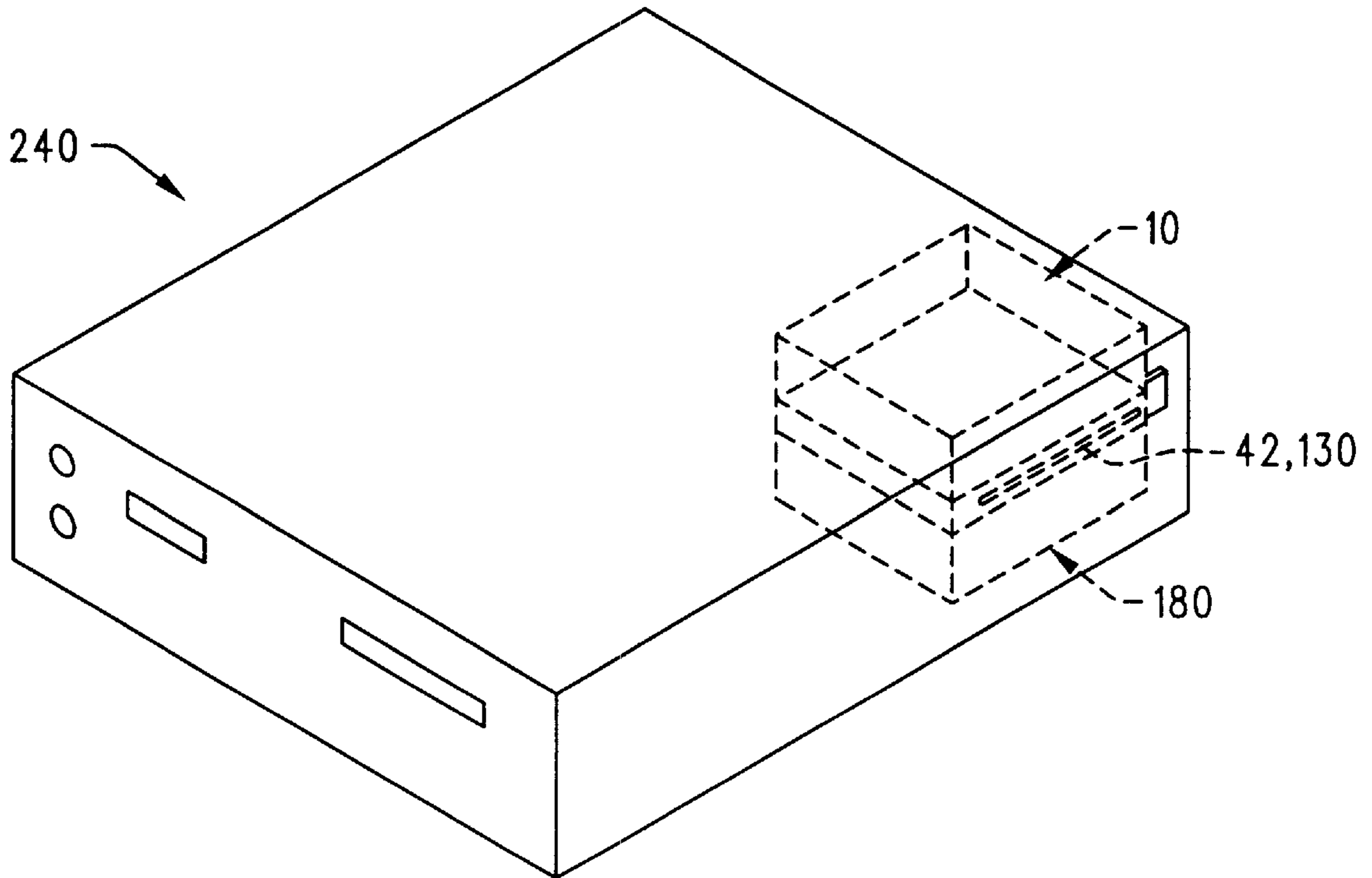

FIG. 17

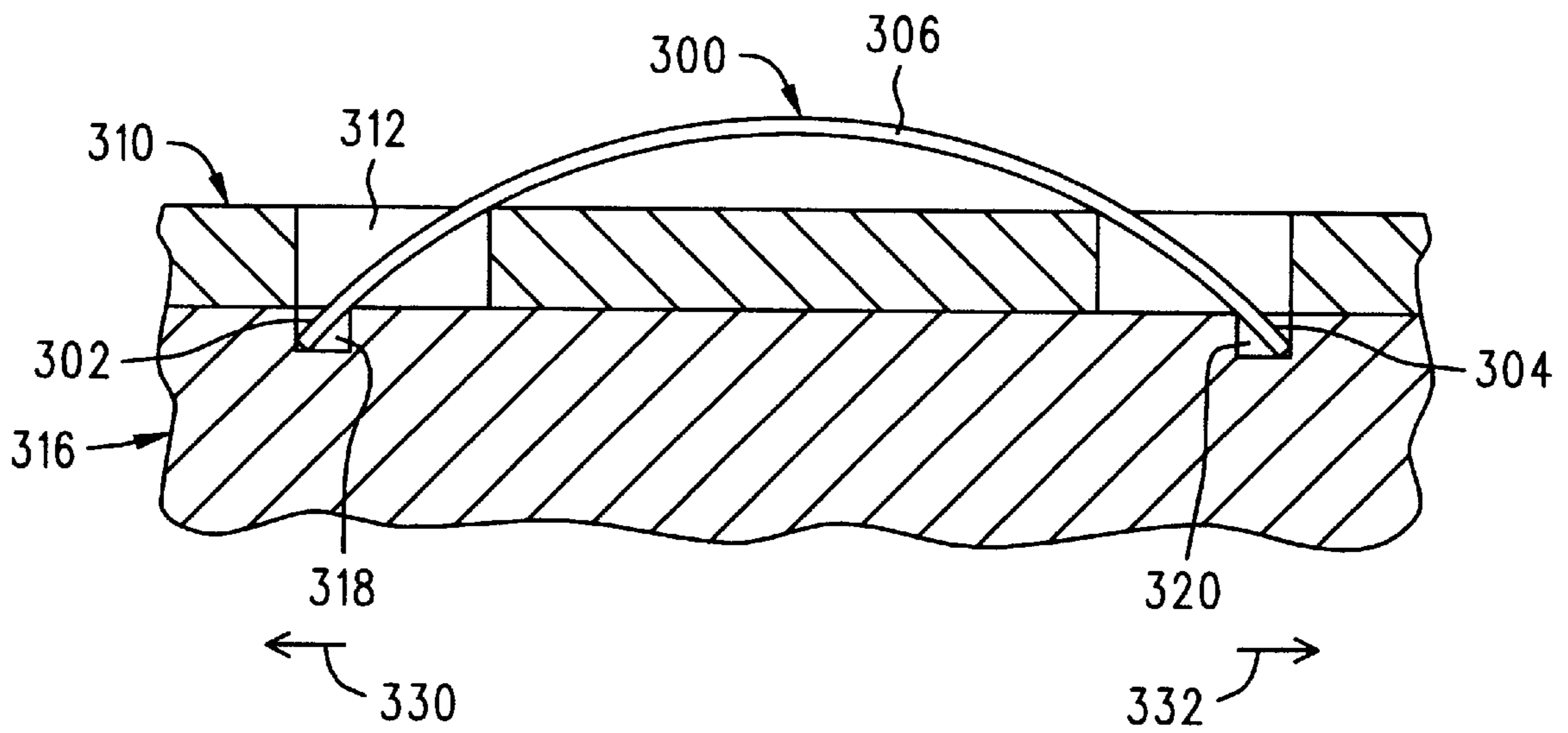



**FIG. 18**



**FIG. 19**



**FIG. 20**

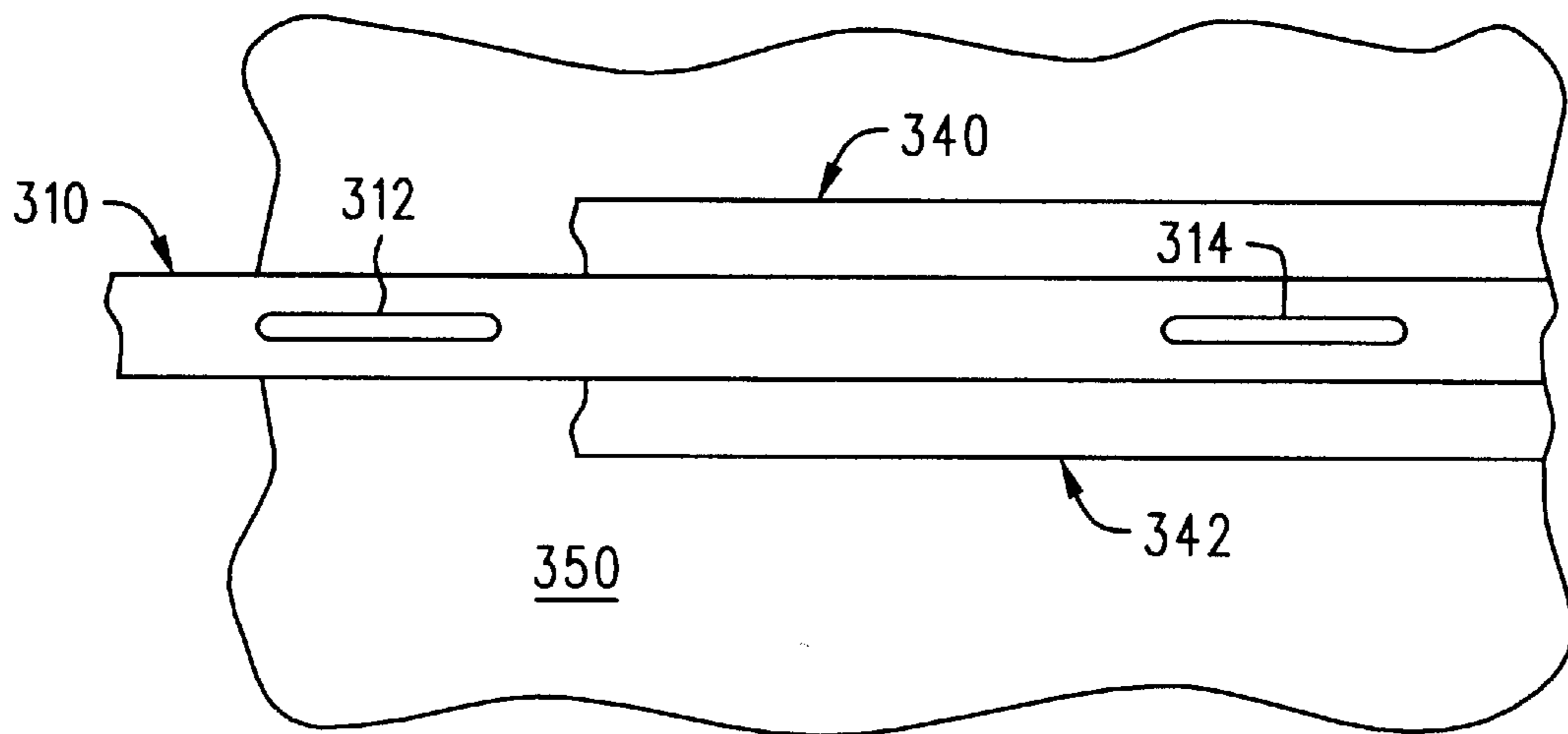

**FIG. 21**

## ELECTRONIC COMPONENT MOUNTING ASSEMBLY AND PORTIONS THEREOF

### BACKGROUND

Many electronic apparatus have modular type components which are mounted in a mounting bracket of the electronic apparatus. An example of such an electronic apparatus is a so called "rack mount" computer system in which various electronic components mounted on pairs of rails are slid into a rack unit which supports and grounds the components and also electrically connects the components to the rest of the computer system. Another example is an automotive electrical system which has exchangeable stereo, compact disk drive, and tape deck units. The units are mounted on rails and slide into and out of a bracket mounted on the car dash board. When fully inserted a unit is electrically connected to the automotive electrical system.

The rails attached to electronic components have traditionally been attached by screws received in threaded bores in the sidewalls of the electronic components. Other means for attaching rails to electronic components are described in U.S. Pat. No. 5,587,889, issued Dec. 24, 1996 of Sacherman and U.S. Pat. No. 5,806,949, issued Sep. 15, 1998 of Johnson, both of which are hereby incorporated by reference for all that is disclose therein.

### SUMMARY OF THE INVENTION

In one embodiment the invention comprises an electronic apparatus including: an electronic component; a rail member positioned adjacent the electronic component; an elongated resilient member extending through the rail member and having an intermediate portion and having first and second end portions engaging the electronic component and applying opposite, outwardly directed forces thereto.

In another embodiment the invention comprises a device for attaching a rack mount slide rail to an electronic component having a pair of spaced apart apertures on one side thereof including: a unitary wire member having a first end portion and a second end portion sized to be received in the spaced apart apertures; the wire member having an unstressed operating state wherein the first and second end portions are spaced apart at a distance greater than the distance between the apertures and having an elastically strained operating state wherein the first and second end portions are spaced apart at substantially the same distance as the distance between the apertures.

In another embodiment the invention comprises a guide rail assembly for use in mounting an electronic component to an electronic apparatus including: an elongated resilient guide rail member having first and second apertures therein; a generally U-shaped wire member having an elongated central body portion and outwardly flared arm portions, the arm portions being received in the first and second apertures.

In another embodiment the invention comprises a method of mounting a rack mount slide rail to an electronic component comprising: attaching an elongated resilient member to the slide rail; elastically inwardly displacing opposite end portions of the resilient member; inserting the elastically inwardly displaced end portions of the resilient member into apertures in the electronic component.

In another embodiment the invention comprises a method of mounting an electronic component in an electrical system including: attaching an elongated resilient member to a slide rail; applying a deforming force to elastically inwardly

displace opposite end portions of the resilient member; inserting the inwardly displaced end portions of the resilient member into apertures in the electronic component; releasing the deforming force so that the end portions deflect outwardly and engage the side walls of the apertures applying outwardly directed force thereto.

In another embodiment the invention comprises an electronic apparatus including: means for receiving at least one electronic components therein; means for slidingly supporting an electronic component received in the means for receiving; means for tensioningly engaging the electronic component for attaching the component to the means for slidingly supporting the component.

### BRIEF DESCRIPTION OF THE DRAWINGS

Embodiments of the invention including the best mode presently contemplated for practicing the invention are illustrated in the attached drawing in which:

FIG. 1 is a perspective view of an electronic component;

FIG. 2 is a perspective view of a rail member;

FIG. 3 is a side view of a rail member;

FIG. 4 is a perspective view of an elongated resilient member;

FIG. 5 is a schematic side elevation view of an elongated resilient member in an unstressed state;

FIG. 6 is a schematic view of an elongated resilient member in a first stressed state;

FIG. 7 is a schematic view of an elongated resilient member in a second stressed state;

FIG. 8 is a detail end view of an elongated resilient member;

FIG. 9 is a detail cross sectional view of portions of a rail member, an elongated resilient member and an electronic component;

FIG. 10 is a detail view of portions of an elongated resilient member and an electronic component;

FIG. 11 is a frontal perspective view of a rail member having an elongated resilient member mounted thereon;

FIG. 12 is another perspective view of a rail member having an elongated resilient member mounted thereon;

FIG. 13 is a perspective view of an electronic component having rail members mounted thereon by elongated resilient members;

FIG. 14 is a top plan view of the assembly of FIG. 13;

FIG. 15 is a right side elevation view of the assembly of FIG. 13;

FIG. 16 is a rear elevation view of the assembly of FIG. 13;

FIG. 17 is a perspective view of an electronic component mounting bracket with one electronic component partially inserted therein and one electronic component fully inserted therein;

FIG. 18 is a detail, cross sectional, view of an electronic component mounted in a mounting bracket;

FIG. 19 is a schematic perspective view of an electronic apparatus having an electronic component mounted in a bracket unit thereof;

FIG. 20 is a schematic cross sectional view of an electronic component having a rail member mounted thereon by an elongated resilient member;

FIG. 21 is a schematic elevation view of the rail member of FIG. 20 received in a mounting bracket.

### DETAILED DESCRIPTION

#### Electronic Component 10

FIG. 1 illustrates an electronic component 10 having a top wall 12, bottom wall 14, front wall 16, back wall 18, left wall

20 and right wall 22. The right wall may be a mirror image of the left wall 20. The left wall and right wall each have at least a pair of apertures 24, 26 therein, which may be conventional threaded bores used for screw attachment of rail members or which may be other type of apertures. Each side wall 20, 22 may have an inside surface 21 and an outside surface 23, FIG. 9. The electronic component may have an electrical connector 11 mounted on the back wall 18. It is to be understood that the designations front, back, left, right, top, bottom are arbitrary and are simply used to facilitate description of the illustrated embodiment. The electronic component 10 may be any type of electronic component which is to be rail mounted, for example a computer hard drive, a DVD drive, a radio, a CD player or a tape deck.

#### Rail Members 40, 42

FIGS. 2 and 3 illustrate rail members 40, 42 which in this particular embodiment are mirror image rail members. Each rail member has a front end portion 44, rear end portion 46, top portion 48, bottom portion 50, bracket facing side portion 52 and electronic component facing side portion 54, FIG. 12. Each rail member 40, 42 may have an elongated smaller height portion 58 and a shorter length, larger height portion 60 integrally formed with the portion 58. The smaller height portion 58 may include a beveled rear tip 62 having top, bottom and front surfaces which taper rearwardly. The smaller height portion 58 may also include a first flat top region 64 connected to a first upwardly arched region 66 which is in turn connected to a second flat top region 68. Region 68 is connected to a second upwardly arched region 70. The sections of portion 58 which include the arched regions 66, 70 have a slightly greater overall height than the sections which include the flat top regions 64, 68. The smaller height portion 58 includes longitudinally extending rib portions 72, 74, 76 defining channels 78, 80 in side portion 50. Each channel has two sidewalls 71, 73 extending between a base wall 75 and a distal edge 77. Within channel 78 are cut out portions 82, 84 positioned below each of the arched regions 66, 70. Channel 80 includes an enlarged channel width region 86 having a cut out 88 extending there through. In the reduced channel width region 90 the sidewalls 71, 73 are positioned closer together at their distal edges 77 than at their edges connected to base wall 75. Channel 80 includes a reduced channel width region 90 which also includes a cut out 91 extending therethrough. Channel 80 further includes enlarged channel width region 92 and normal channel width region 94. Region 94 terminates at an enlarged channel width region 96 which is in turn connected to a reduced channel width region 98 which is positioned within the larger height portion 60 of the rail member. A cut out 99 extends through the reduced channel width region 98. In region 98, like region 90, the channel side walls 71, 73 are closer together at their open edges than at their edges attached to base 75. Region 98 is connected to a channel opening region 100 which includes a cut out 102 extending therethrough. The larger height portion 60 of each rail member may include a transverse rear rib 106 and a transverse front rib 108 which define a retention slot 110 therebetween. The larger height portion 60 also includes a front tab 112 terminating in a transverse front lip 114. Each rail member 40, 42 may be an integrally formed rail member and may be constructed from a high strength, relatively stiff, resilient material such as high strength plastic, e.g. PC, ABS, or blends of PC and ABS.

#### Elongated Flexible Member 130

FIG. 4 illustrates an elongated flexible member 130. Schematic drawings of the elongated flexible member 130

are provided in FIGS. 5-7 which show certain curves, angles, lengths, etc., are exaggerated to facilitate description. The elongated flexible member 130, in one embodiment, is a heavy gauge, e.g., 2 mm diameter, steel wire member. However, any relatively stiff, resilient material which is also a good electrical conductor may be used, such as titanium or beryllium copper wire. The elongated flexible member 130 may be a generally U-shaped member having a central body portion 132 with first and second arm portions 134, 136 connected thereto by shoulder portions 138, 140. The shoulder portions connect the arm portions to the central body portion at angles "a" and "b" which are preferably obtuse angles i.e. greater than 90 degrees. In the illustrated embodiment the first arm portion 134 has a flattened end portion 142 having a generally rectangular outer face 144 having parallel edge portions 146, 148, FIG. 8. The second arm portion 136 may terminate in a cylindrical end portion 152 having the same diameter as the rest of the wire member. Although a cylindrical end portion and a flat end portion are shown in the illustrated embodiment it is to be understood that many other shapes, such as threaded or roughened surface shapes, etc., may be used for either or both end portions. The central body portion 132 includes a bowed portion 156. The bowed portion may include a straight center portion 158 having arcuate portions 160, 162 integrally attached at either end thereof. The bowed portion 156 may be attached to straight portions 164, 166 which are in turn connected to shoulder portions 138, 140.

FIGS. 5-7 illustrate the effect of application of different forces to the bowed portion 156 of the flexible member 130 when the member is supported at the lower surface of straight portion 164, 166, as by channel base wall 75 of rail member 40 or 42 which lies in a plane xxx. FIG. 5 shows the member 130 in an unstressed state wherein the distance between the lower surface of straight center portion 158 and plane xxx is  $h_1$  and the distance between the end portions 142, 152 is  $d_1$ . FIG. 6 illustrates the member 130 in a stressed state in which a force 170 directed away from plane xxx is applied to the straight center portion 158 of the bowed portion. The end portions 142, 152 of the member 130 are prevented from moving in the direction of force 170 by a oppositely directed forces 171, 173 applied to portions 164, 166, as by channel sidewalls 71, 73 of member 40 or 42. As a result of application of these forces the bowed portion 156 is caused to be relatively more flexed than in FIG. 5 and the distance  $h_2$  between center portion 158 and plane xxx is greater than the distance  $h_1$ . Also the distance  $d_2$  between end portions 142, 152 is shorter than the distance  $d_1$ . FIG. 7 illustrates the effect of a force 172 directed opposite to force 170 applied to straight center portion 158 with the member 130 supported at the lower surfaces of straight portions 164, 166 by a fixed surface of xxx, such as channel base wall 75. The ends 142, 152 are urged outwardly as a result of force 172 but are restrained against displacement in directions 143, 153 by fixed surfaces 141, 151 spaced at a distance  $d_3$  slightly less than  $d_1$ . The bowed portion 156 is flexed less than in either FIG. 5 or 6 and the bow shape is slightly flattened and thus height  $h_3$  is less than  $h_1$  or  $h_2$ . Ends 142, 152 are urged outwardly, in directions 143, 153, respectively, as a result of application of force 172 and thus apply an outwardly directed force to surfaces 141, 151.

#### Mounting Bracket 180

A rack mount type mounting bracket 180 is illustrated in FIG. 17. The mounting bracket includes parallel side walls which in the illustrated embodiment are mirror image sheet metal side walls 182, 184. The side walls have oppositely

positioned rail receiving portions **186, 188, 190**, etc. therein, with the rail receiving portions in side wall **184** being mirror images of the rail receiving portions in side wall **182**. The rail receiving portions are adapted to position an inserted electronic component into alignment with an associated electrical connector **194, 196, 198**, etc. mounted on a back wall **202**. Each of the rail receiving portions in the illustrated embodiment is defined by opposed sets of upper flanges **212, 214, 216** and lower flanges **218, 220, 222**. It is to be understood, however, that there are many different structures which may be used for providing rail receiving portions in a bracket, including but not limited to slots formed in a wall studs, and opposed, parallel, stationary receiving rails. In the illustrated embodiment each of the rail receiving portions **186, 188** etc. has a transverse retaining flange **230, 232** etc., positioned at a front end portion thereof.

#### Mounting of Rail Members **40, 42** to Electronic Component **10**

The manner in which rail members **40, 42** are mounted on an electronic component **10** with elongated flexible members **130** will now be described. Initially, elongated flexible members **130** are mounted on rail members **40, 42**. Mounting may be accomplished by inserting one end portion e.g., **142** of flexible member **130** into cut out **102** and the other end portion **152** into rail cut out **88**. After the end portions are inserted in the apertures the member **130** may be pushed toward the rail member **40** or **42** until straight portions **164, 166** come into contact with the base wall **75** of rail member channel **80**. The reduced width regions **90, 98** of channel **80** may be constructed and arranged so that the sidewalls **71, 73** thereof receive the flexible member in snap-fit, resiliently holding relationship. The distance between cut outs **88** and **102** are such that the flexible member **130**, when it is fully inserted into a rail member **40** or **42**, is in the generally unstressed state illustrated in FIG. **5**. The height of the rib portions **74, 76** and the bow height distance  $h_1$  of the bowed portion **156** are such that the straight center portion **158** of the bowed portion projects slightly away from the outer surfaces of ribs **74, 76** thus enabling an operator to easily insert a tool, fingernail or the like between the surface of straight center portion **158** and the adjacent surfaces of the ribs. With the straight center portion **158** thus engaged with a tool, etc., the straight center portion is pulled away from the ribs, in the direction **170** shown in FIG. **6**, with the straight portions **164, 166** being maintained in the channel by gripping contact with the reduced channel regions **90, 98** of channel **80** or through application of external force thereto in directions **171, 173**. The elongated flexible member **130** is thus elastically deformed into a shape such as illustrated in FIG. **6** with end portions **142, 152** positioned at a distance  $d_2$  which is slightly less than the distance between the outsides of apertures **24, 26** in the electronic component.

With the elongated flexible member **130** thus flexed the end portions **142, 152** are inserted into apertures **24, 26** and the entire rail member and flexible member assembly **40/130** is thereafter urged toward the electronic component **10** until side portion **54** of the rail member makes abutting contact with the sidewall surface **20** or **22** of the electronic component **10** and the terminal ends of end portions **142, 152** are positioned below the inside surface **21** of the component **10** side wall **20** or **22**. Thereafter the force applied by tool or fingernail to the straight center portion **158** of the flexible member is released. As a result the end portions **142, 152** move outwardly slightly until engaging the outer periphery of the apertures **24, 26** as shown in FIG. **9**. The apertures

**24, 26** may be positioned somewhat more closely e.g., 2 mm more closely, than the distance  $d_1$  between flexible member end portions **142, 152** when the flexible member is in the unstressed state. As a result the flexible member **130** applies an outwardly directed force, i.e., in directions **143, 153** respectively against the outer wall of each aperture **24, 26** as illustrated in FIGS. **7, 9** and **10**.

Because the end portions **142** and **152** are angled outwardly, and because the wall of apertures **24, 26** are substantially perpendicular to the surface of component **10**, and because the wall of component **10** is relatively thin, the end portions **142, 144** may extend through the electronic component wall **20** and outwardly, as shown in FIG. **9** thereby resisting removal because of the wedge like interfering contact with the inside surface **21** of wall **20** at the bottom of the aperture. Also, the friction associated with surface contact between the threaded apertures and the end portions **142, 152** resists removal of the end portions **142, 152** from the bores **24, 26**.

The use of an end portion, e.g. **142**, with a flattened or rectangular surface **144** in association with a round bore aperture, e.g. **34**, creates two bearing edges **146, 148**, FIGS. **8** and **10** which add to the "bite" on the aperture wall which resists removal of the end portion from the aperture. (In another embodiment, not shown, a retaining nub is placed at the end of the flexible member end portions **142, 152** such that the nub projects slightly outwardly **143**, beneath electronic component wall surface **21** when the flexible member is inserted so as to create a further resistance to removal). In order to remove the rail member from the electronic component **10** a reverse procedure is performed, i.e. the elongated flexible member is flexed so that the end portions **152, 154** move closer together and into a slightly more parallel relationship thus enabling the flexible member to be removed from apertures **24, 26**.

FIGS. **13–16** illustrate an electronic component **10** having rail members **42, 44** mounted thereon through the use of elongated flexible members **130**. The flexible members **40, 42** are positioned in parallel alignment with the left and right side walls **20, 22** of the component **10**. As a result of outwardly directed **143, 153** forces applied to the outer walls of the apertures by the ends **142, 152** of the flexible member the rail members are held securely to component **10** and the entire component and rail member assembly may be picked up by grasping tab portions **112** of the rail members **40, 42**.

#### Mounting of Component **10** in Mounting Bracket **180**

The manner in which the component **10** with attached rails **40, 42** is mounted in mounting bracket **180** will now be described. The distance between the side walls of **182, 184** of the mounting bracket **180** is slightly greater than the distance between the outer surfaces of rails **40, 42** when the rails are mounted on component **10**. The distance between the parallel side walls **182, 184** is slightly less than the distance between the outer surfaces of the straight center portion **158** of the elongated flexible members **130** associated with each rail **40, 42**, such that when the component rail assembly is mounted between the bracket parallel side rails **182, 184** the elongated flexible members **130** are slightly inwardly, elastically deformed, as shown in FIG. **7**, by the corresponding side walls **182, 184**.

To begin the insertion process the beveled rear tip portion **62** of each rail **40, 42** is initially pushed in to a selected one of the rail receiving portions, e.g. **186, 188**. The component and rail member assembly is then pushed into the bracket

member with the rail receiving portions **186, 188** acting to align the rail member and component assembly with an associated electrical connector **194** such that a corresponding electrical connector **11** on the back wall **18** of the component is electrically connected when the component/rail assembly is fully inserted into the mounting bracket **180**. Near the end of the insertion operation the rear rib **106** on each bracket member passes over an associated retaining flange **230, 232** on the bracket member causing the larger height portion **60** of the bracket member to first flex outwardly and then snap back such that the retaining flange **230, 232** is positioned in the retention slot **110** located between ribs **106, 108** on the rail member. The retention slot **110** thus acts to hold the electronic component and rail assembly in the mounting bracket **180** preventing it from being pulled out of the bracket until the front tab **112** is grasped and flexed laterally inwardly to release the associated retaining flange **230** or **232** from slot **110**.

FIG. **18** illustrates the relative positions of various portions of the rail member **42**, flexible member **130** and mounting bracket side wall **182** when the component and rail member assembly is mounted in the mounting bracket **180**. The arched regions **66, 70** of each rail member **40, 42** are constructed and arranged such that they are positioned below corresponding ones of upper flanges **212, 216** of the bracket when the assembly **10/40/42** is fully inserted into the bracket. The spacing between opposite upper and lower flanges, e.g., **212, 218** is such that an upper and lower associated arched regions **66** is slightly compressed thereby and yet the flanges **212, 218** are positioned sufficiently far apart such that the flat top regions **64, 68** are not compressed thereby as they slide between the flanges **212, 218** during insertion. As a result it is relatively easy to slide the component/rail assembly into the bracket **180** and yet once it is in place it is firmly held in place resisting any upward and downward movement between the rail members **40, 42** and the bracket **180**.

As also shown by FIG. **18** the elongate flexible member **130** straight center portion **158** has been urged slightly inwardly into channel **80** by side wall **186** which corresponds to the operating state shown by FIG. **7**. Thus flexible member **130** makes pressurized contact with the sheet metal wall surface of the bracket **180** as well as making pressurized contact with the wall of electronic component **10**. This pressurized contact provides a good electrical connection between the elongated flexible member and the bracket **180** and also the flexible member and the electronic component **10**. In fact the compressive forces on the elongated flexible member **130** associated with mounting in bracket **180** acts to increase the pressure of the contact with electronic component above the pressure that existed before mounting of the component/rail assembly in bracket **180**. Thus the component **10** is placed in electrically conductive relationship with the electrically conductive mounting bracket **180** enabling the component **10** to be grounded to an associated chassis, etc. of the electronic apparatus **240** to which the mounting bracket is groundedly attached, FIG. **19**. Also, this compression of the elongated flexible member **130** on each side of the electronic component **10** holds the component **10** in a stable lateral relationship with the bracket **180**. The compressive force exerted on the elongated flexible member also adds to the outward forces that it applies on the component **10**, placing the portion of component **10** positioned between apertures **24, 26** under increased tension. This increase in outwardly directed force also increases the wedging force and frictional force between component **10** aperture and inside walls and member **130**, thus ensuring that the rail

members **40, 42** will remain securely attached to component **10** when it is mounted in bracket **180**.

#### Another Embodiment

FIGS. **20** and **21** illustrate another embodiment of an elongated flexible member **300** having end portions **302, 304** and a bowed portion **306** which attaches a generally box shaped rail member **310** having elongated slots **312, 314** therein to an electronic component **316** having holes **318, 320**. The end portions of the elongated flexible member **300** apply outward force **330, 332** on the side walls of holes **318, 320**. In this embodiment the elongated flexible member **300** may be a straight component which is elastically deformed into the bowed shape illustrated in FIG. **20**. In this embodiment the component rails **310** are received within a mounting bracket having opposite parallel receiving rails **340, 342** affixed to the bracket side wall **350**.

Many alternative constructions of a conductive, elongated flexible member will be obvious to those skilled in the art who have read the above description. For example a member with multiple bowed portions, which when elastically flattened provide outwardly directed forces on engaged holes of an electronic component could be used instead of member **130**, or **300**.

While illustrative and presently preferred embodiments of the invention have been described in detail herein, it is to be understood that the inventive concepts may be otherwise variously embodied and employed and that the appended claims are intended to be construed to include such variations except insofar as limited by the prior art.

What is claimed is:

1. An electronic apparatus comprising:

an electronic component;

a rail member positioned adjacent said electronic component;

an elongated resilient member extending through said rail member and having an intermediate portion and having first and second end portions engaging said electronic component and applying opposite, outwardly directed forces thereto.

2. The electronic apparatus of claim 1, further comprising: a component mounting bracket having a rail receiving portion, wherein said first rail member is received in said rail receiving portion; and

wherein said elongated resilient member has said intermediate portion positioned in abutting contact with said component mounting bracket.

3. The electronic apparatus of claim 2 wherein said elongated resilient member is an electrically conductive member in electrical contact with electrically conductive portions of said electronic component and said component mounting bracket.

4. The electronic apparatus of claim 1:

said electronic component having first and second apertures; and

said elongated resilient member first and second end portions being received in said first and second apertures.

5. The electronic device of claim 1 wherein said first and second end portions of said elongated resilient member project outwardly relative to said intermediate portion.

6. The electronic apparatus of claim 1 and further comprising:

a component mounting bracket having a rail receiving portion, wherein said first rail member is received in said rail receiving portion; and  
 wherein said elongated resilient member is an electrically conductive member and said elongated resilient member has an intermediate bowed portion positioned in electrically conductive, compressive contact with said component mounting bracket.

7. The electronic apparatus of claim 6:  
 said electronic component having first and second apertures; and  
 said elongated resilient member first and second end portions being received in said first and second apertures in electrically conductive contact with walls defining said apertures.

8. The electronic apparatus of claim 6, said rail member comprising at least one aperture, at least one of said elongated resilient member first and second end portions extending through said at least one aperture.

9. The electronic apparatus of claim 8, said at least one aperture comprising a first aperture and a second aperture adapted to receive, respectively, said first end portion and said second end portion of said elongated resilient member.

10. The electronic apparatus of claim 9, said rail member further comprising a channel portion, said intermediate bowed portion of said elongated resilient member being resiliently deflectable into said channel portion.

11. The electronic apparatus of claim 10 said elongated resilient member comprising at least one straight portion positioned between said intermediate bowed portion and one of said end portions and said channel portion comprising at least one reduced cross section portion adapted to resiliently receive and hold said straight portion of said elongated resilient member.

12. The electronic apparatus of claim 11, said component mounting bracket rail receiving portion comprising opposed sheet metal flanges, said rail member comprising at least one arcuate portion adapted to be resiliently deformed by sliding said rail member between said opposed sheet metal flanges.

13. The electronic device of claim 12 wherein said first and second end portions of said elongated resilient member project outwardly relative to said intermediate portion.

14. The electronic device of claim 1 wherein said first and second end portions of said elongated resilient member project outwardly relative to said intermediate portion.

15. The electronic device of claim 14, at least one of said end portions of said elongated resilient member comprising a flat portion.

16. A device for attaching a rack mount slide rail to an electronic component having a pair of spaced apart apertures on one side thereof comprising:  
 a unitary wire member having a first end portion and a second end portion sized to be received in said spaced apart apertures; said wire member having an unstressed operating state wherein said first and second end portions are spaced apart at a distance greater than the distance between said apertures and having an elastically strained operating state wherein said first and second end portions are spaced apart at substantially the same distance as the distance between said apertures.

17. The device of claim 16 said wire member having an intermediate bowed portion, said first and second end portions being positionable relatively closer together by increasing the curvature of said bowed portion.

18. The device of claim 17, said unitary wire member comprising a generally U-shaped member having a central body portion and first and second arm portions projecting from opposite ends of said central body portion, said central body portion comprising said intermediate bowed portion, said first and second arm portions comprising said first and second end portions of said wire member.

19. The device of claim 18, said arm portions extending outwardly relative to said central body portion.

20. The electronic device of claim 19, at least one of said end portions of said elongated resilient member comprising a flat portion.

21. A guide rail assembly for use in mounting an electronic component to an electronic apparatus comprising:  
 an elongated resilient guide rail member having first and second apertures therein;  
 a generally U-shaped wire member having an elongated central body portion and outwardly flared arm portions, said arm portions located in generally coplanar relationship with said body portion, said arm portions being received in said first and second apertures;  
 said wire member central body portion comprising at least one bowed portion;  
 said arm portions having terminal end portions; said wire member having an unstressed operating state with said terminal end portions spaced apart at a first distance and having a second operating state with said terminal end portions spaced apart at a second distance shorter than said first distance; said wire member being placed in said second operating state by elastically deformingly increasing the curvature of said bowed portion.

22. The guide rail assembly of claim 21, said guide rail comprising a channel portion, said bowed portion being deflectable into said channel portion through application of bow flattening pressure thereto.

23. The guide rail assembly of claim 22, said channel portion comprising a reduced cross section portion sized to retainingly receive a portion of said central body portion of said member.

24. A method of mounting a rack mount slide rail to an electronic component comprising:  
 attaching an elongated resilient member to the slide rail;  
 elastically inwardly displacing; opposite end portions of said resilient member;  
 inserting the elastically inwardly displaced end portions of resilient member into apertures in the electronic component.

25. The method of claim 24 wherein elastically inwardly displacing the opposite end portions comprised flexing at least one bowed portion of the resilient member.

26. A method of mounting an electronic component in an electrical system comprising:  
 attaching an elongated resilient member to a slide rail;  
 applying a deforming force to elastically inwardly displace opposite end portions of said resilient member;  
 inserting the inwardly displaced end portions of resilient member into apertures in the electronic component;  
 releasing the deforming force so that the end portions deflect outwardly and engage the side walls of the apertures applying outwardly directed force thereto.

27. The claim of claim 26 further comprising:  
 sliding the slide rail into a rack portion of the electrical system while compressing the elongated resilient mem-

**11**

ber between the rack portion and the electronic component to apply additional outwardly directed force to the side walls of the apertures.

**28.** An electronic apparatus comprising:

means for receiving at least one electronic components therein;

means for slingly supporting an electronic component received in said means for receiving;

**12**

means for tensioningly engaging said electronic component for attaching said component to said means for slidingly supporting said component.

**29.** The electronic apparatus of claim **28** wherein said means for tensioningly engaging comprises means for grounding said electronic component to said means for receiving.

\* \* \* \* \*