



US006569327B2

(12) **United States Patent**
Roberts et al.

(10) **Patent No.:** **US 6,569,327 B2**
(45) **Date of Patent:** **May 27, 2003**

(54) **APPARATUS FOR DIRECTING FLUIDS THROUGH A FILTER SYSTEM**
(75) Inventors: **R. Lee Roberts**, Chadds Ford, PA (US);
Mark Kevin Addison, Bear, DE (US)
(73) Assignee: **RG Delaware, Inc.**, Willmington, DE (US)
(*) Notice: Subject to any disclaimer, the term of this patent is extended or adjusted under 35 U.S.C. 154(b) by 0 days.

5,232,592 A 8/1993 Brown
5,269,920 A 12/1993 Brown
5,462,664 A 10/1995 Neuspiel
5,489,388 A 2/1996 Brown
5,534,202 A 7/1996 Roberts
5,618,426 A 4/1997 Eischen
5,639,384 A 6/1997 Brown
5,865,774 A * 2/1999 Brenman et al. 602/19
5,865,999 A 2/1999 Shea
6,048,132 A 4/2000 Kupke et al.
6,090,284 A 7/2000 Melber
6,143,188 A 11/2000 Jantsch
6,190,568 B1 2/2001 Hunkele
6,325,931 B1 12/2001 Roberts

(21) Appl. No.: **09/766,631**

FOREIGN PATENT DOCUMENTS

(22) Filed: **Jan. 23, 2001**

WO WO 97/00110 1/1997

(65) **Prior Publication Data**

OTHER PUBLICATIONS

US 2002/0096463 A1 Jul. 25, 2002

(51) **Int. Cl.**⁷ **B01D 24/22; B01D 24/26**
(52) **U.S. Cl.** **210/274; 210/293**
(58) **Field of Search** **210/274, 275, 210/293, 169**

Brochure on "Infinity continuous lateral underdrain" copyrighted 1999.
"Leopold Universal Type S Underdrain. The Proven Stanard of Excellence Made Better!" copyrighted 1994.

* cited by examiner

(56) **References Cited**

Primary Examiner—Robert J. Popovics
(74) *Attorney, Agent, or Firm*—Merek, Blackmon & Voorhees

U.S. PATENT DOCUMENTS

3,110,667 A 11/1963 Stuppy
3,685,657 A 8/1972 Hunter
3,956,134 A 5/1976 Sturgill
4,118,322 A 10/1978 San Roman
4,579,659 A 4/1986 Eads et al.
4,619,765 A 10/1986 Roberts
4,707,257 A 11/1987 Davis
4,817,561 A * 4/1989 Byrne et al. 210/169
5,068,034 A 11/1991 Walter
5,087,362 A 2/1992 Brown
5,108,627 A 4/1992 Berkebile
5,149,427 A 9/1992 Brown
5,160,614 A 11/1992 Brown

(57) **ABSTRACT**

A fluid distribution system for directing fluids through a filter system. The fluid distribution system ensures proper distribution of fluids during the process of filtering as well as the process of washing a filter bed. The fluid distribution system may be used with numerous filter systems including but not limited to an upflow filter, a downflow filter, a combined upflow/downflow filter and/or multiple downflow filters connected in series.

18 Claims, 16 Drawing Sheets

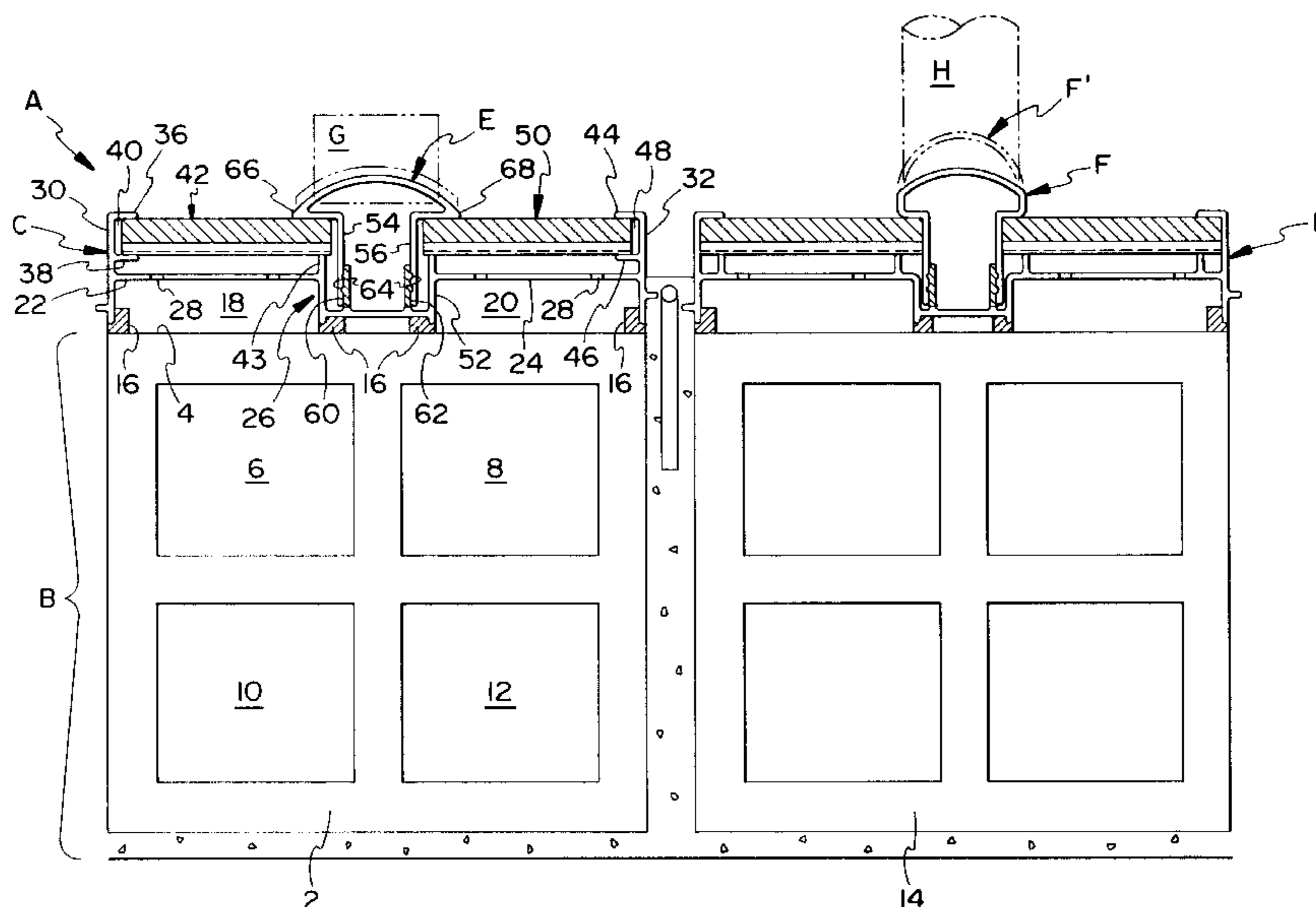

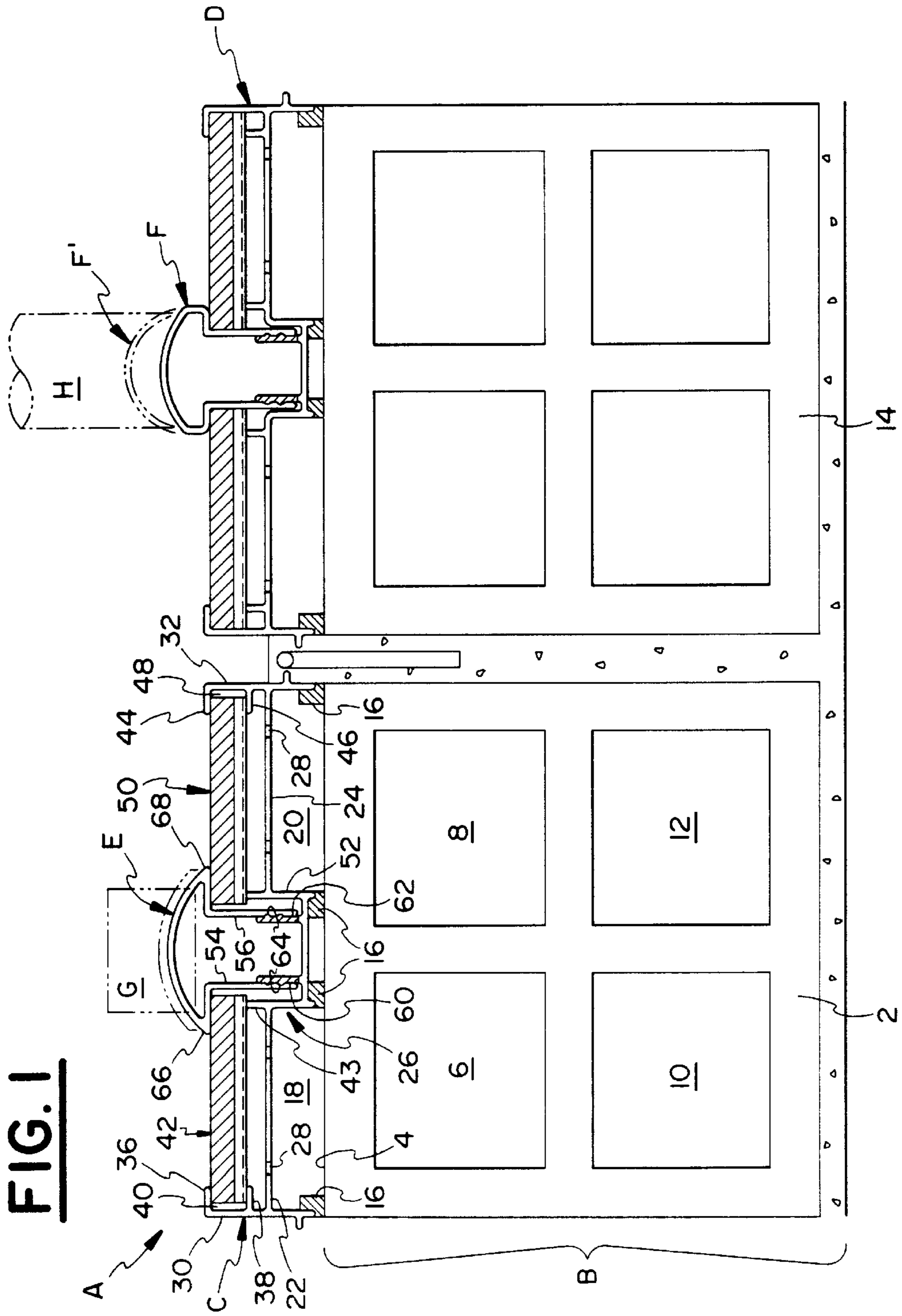

FIG. 1

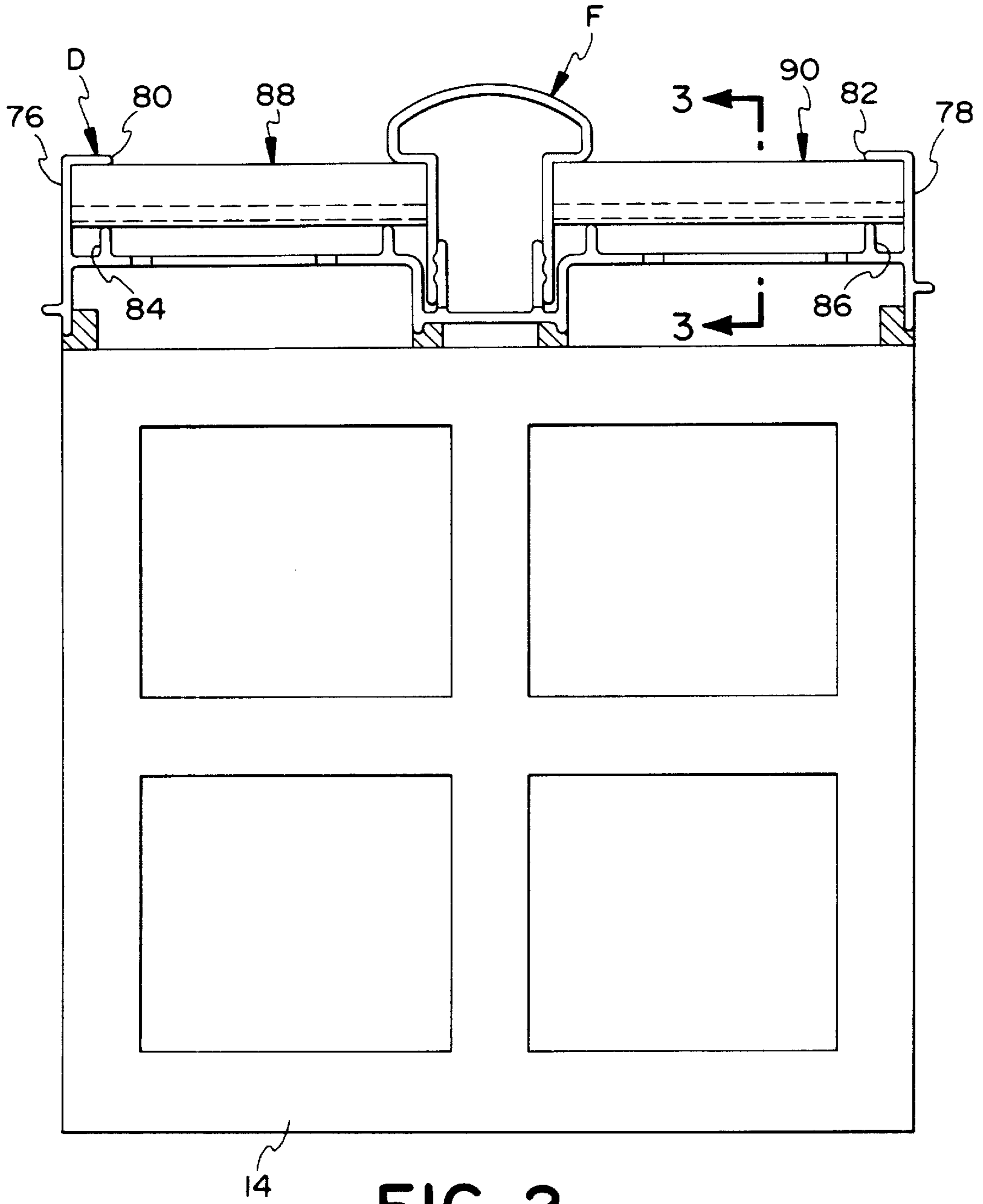

FIG. 2

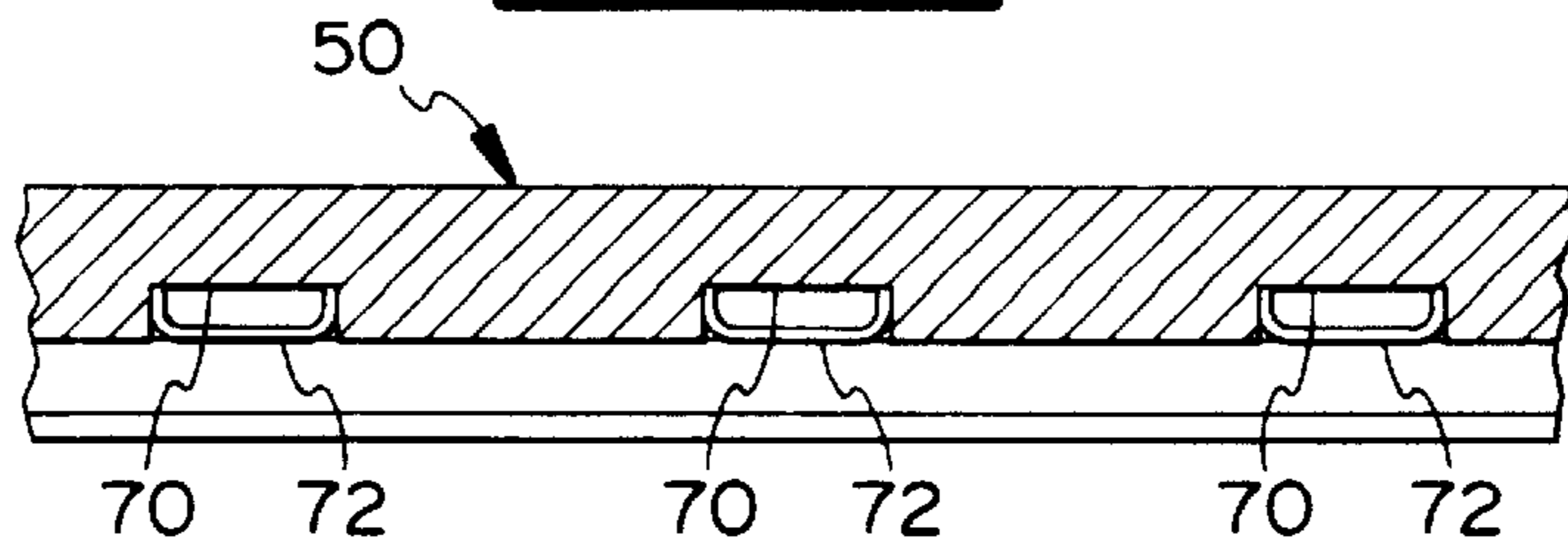
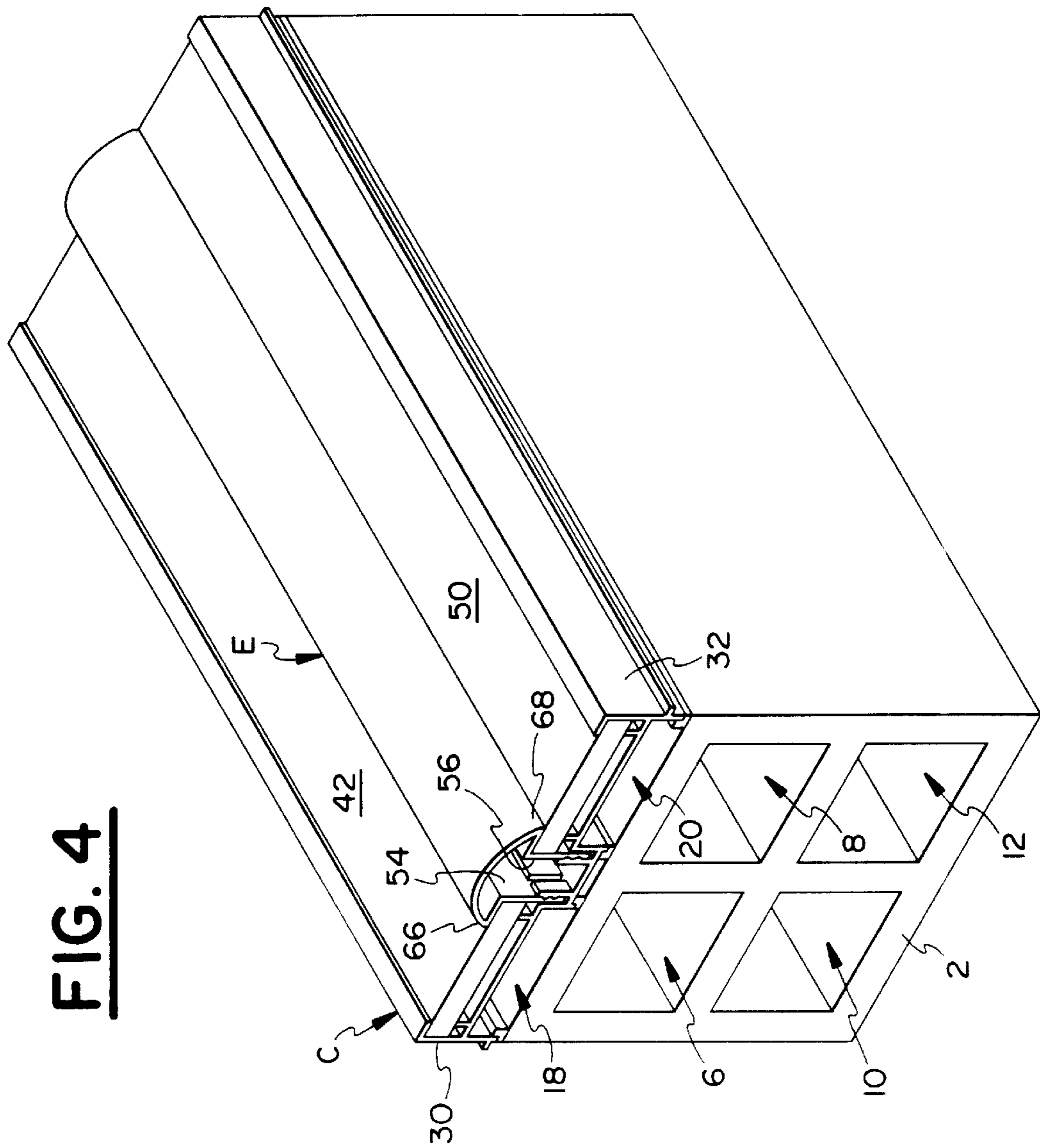

FIG. 3



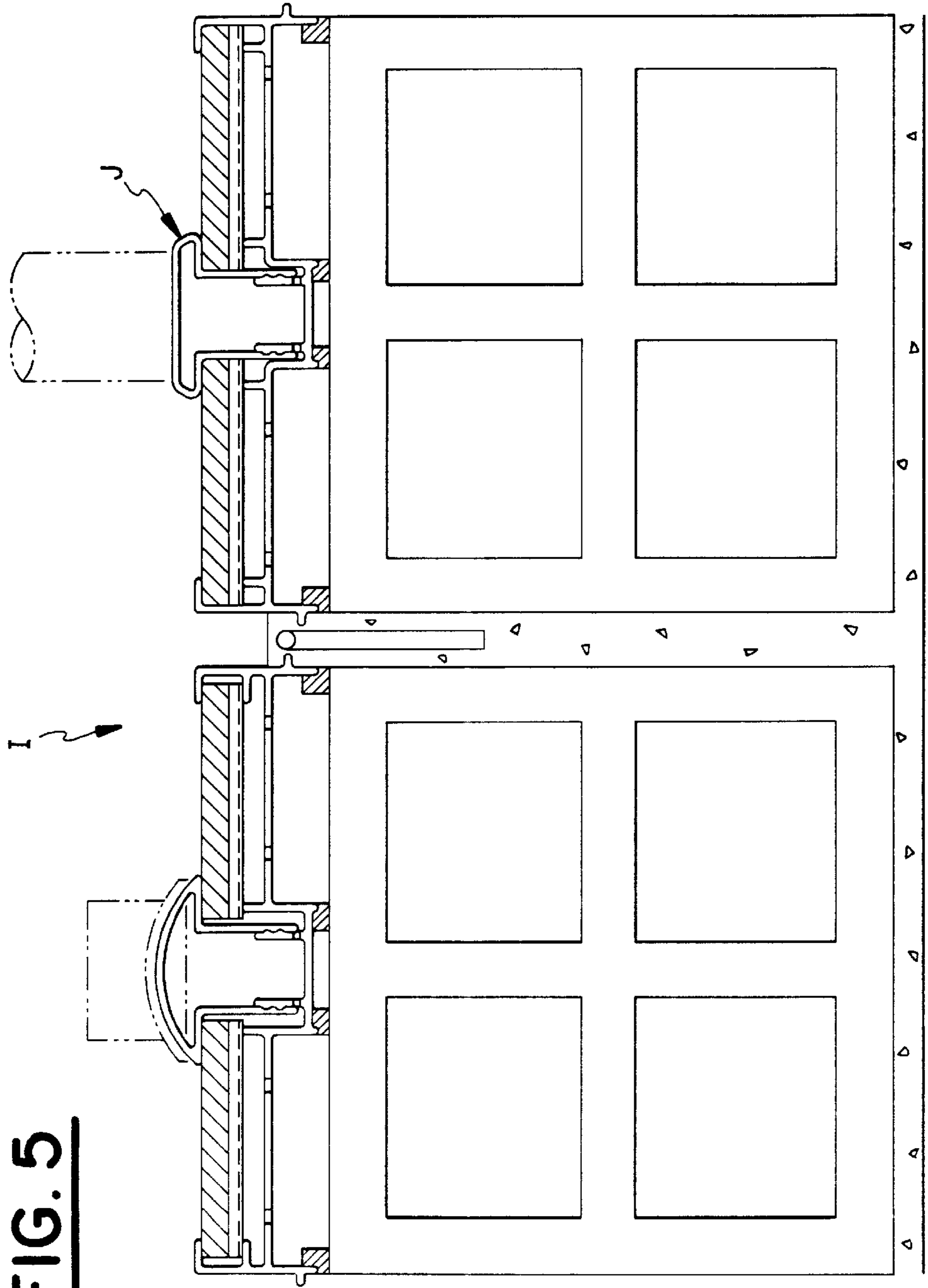

FIG. 5

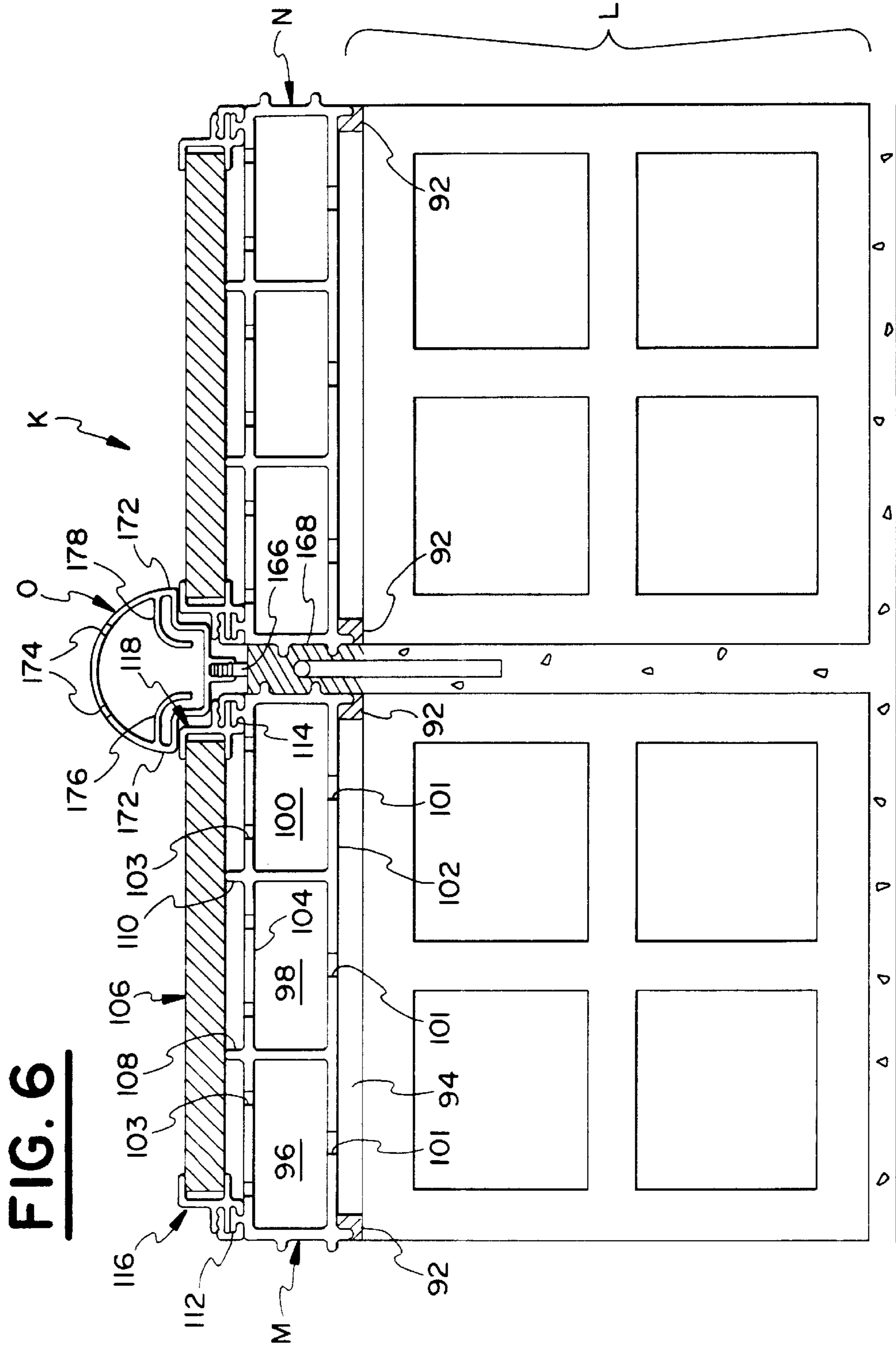

FIG. 6

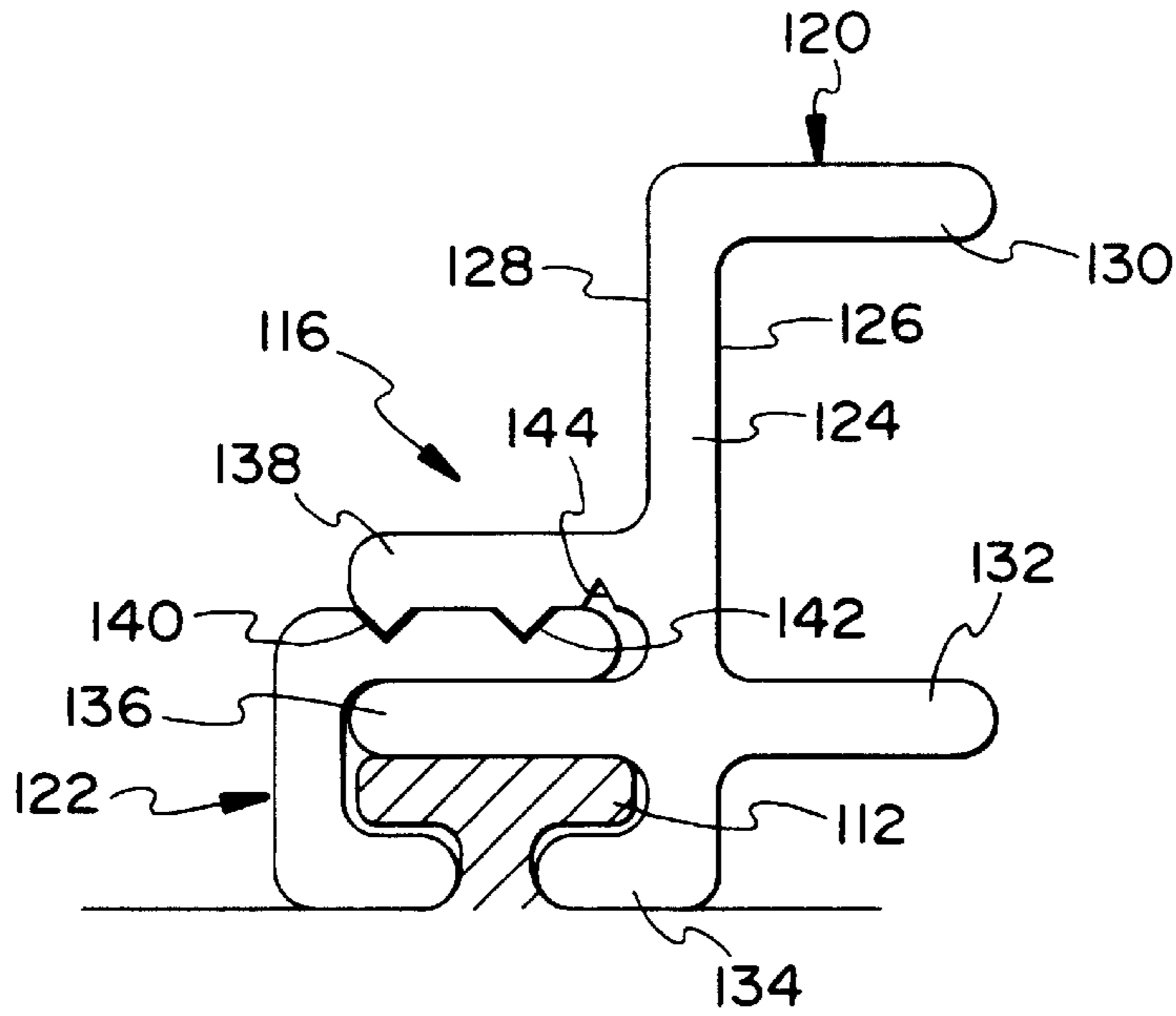

FIG. 7

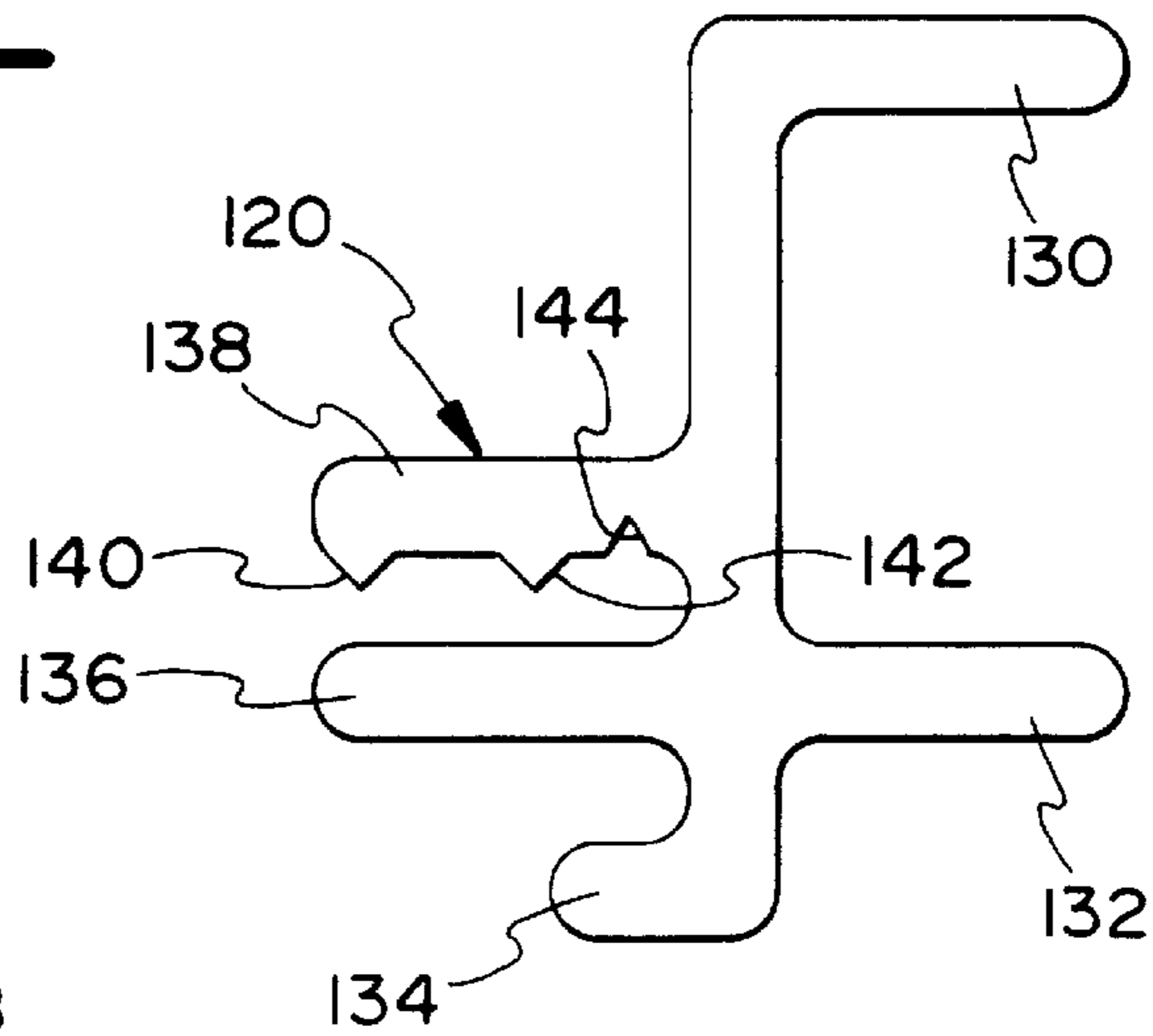

FIG. 8

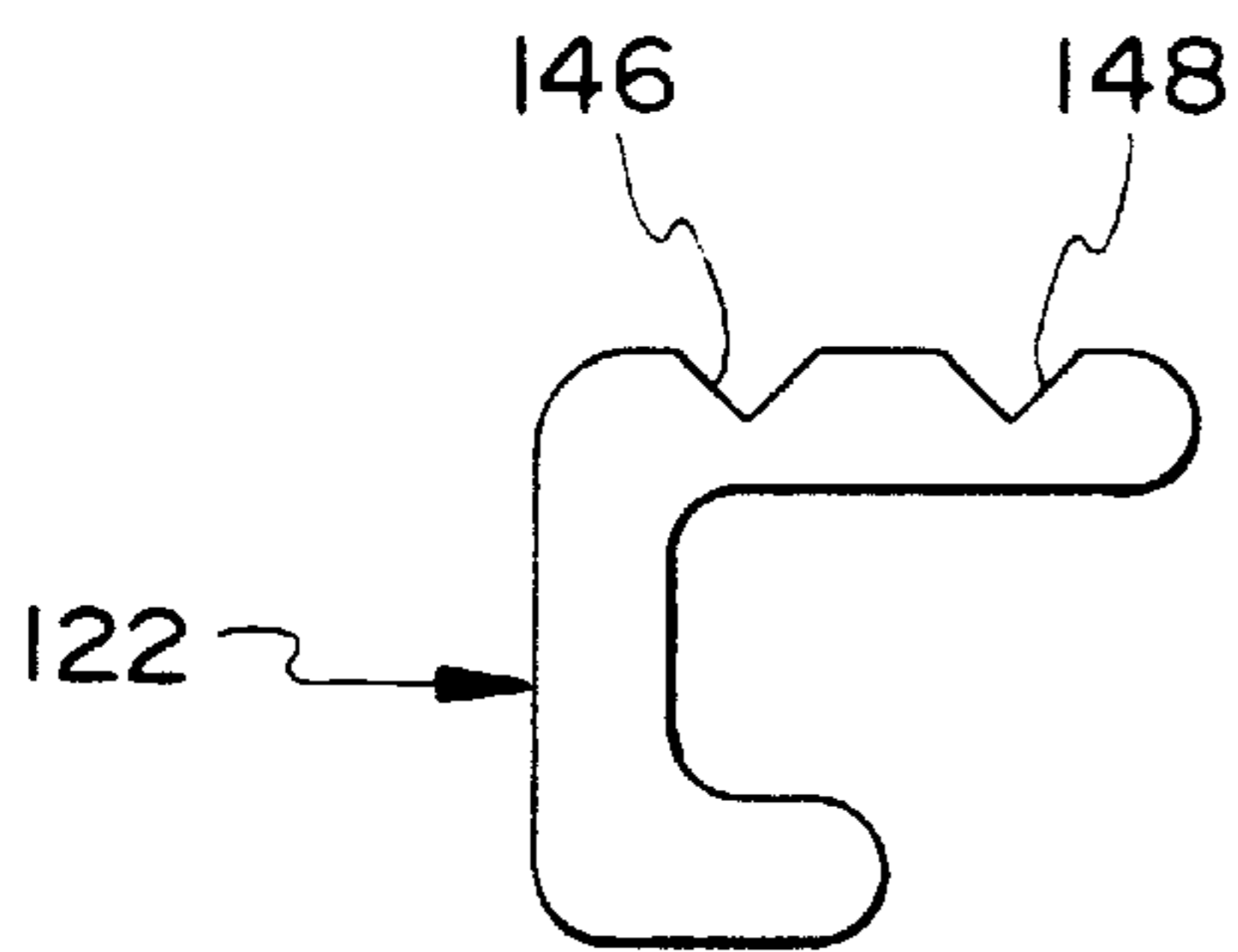

FIG. 9

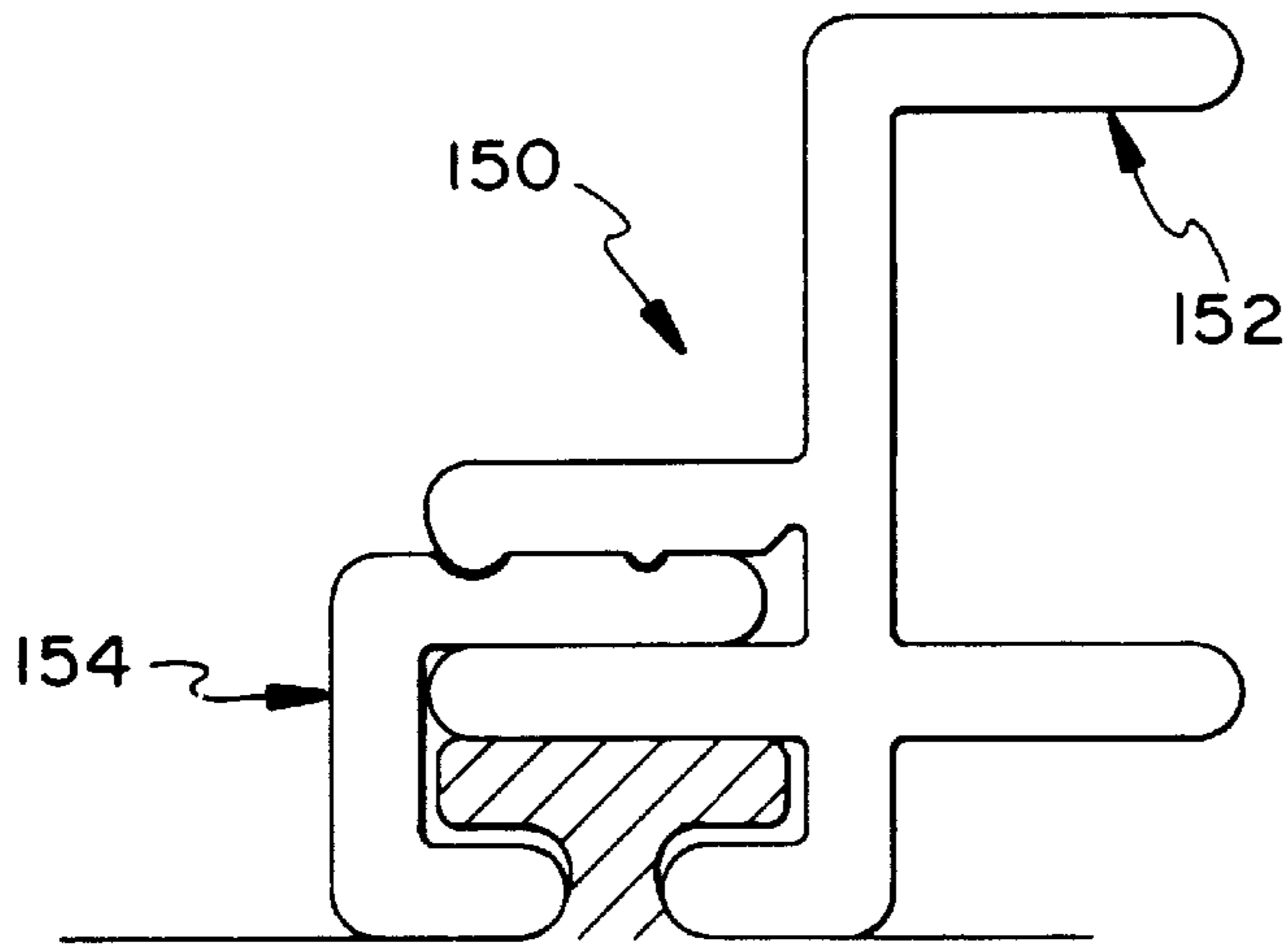

FIG. 10

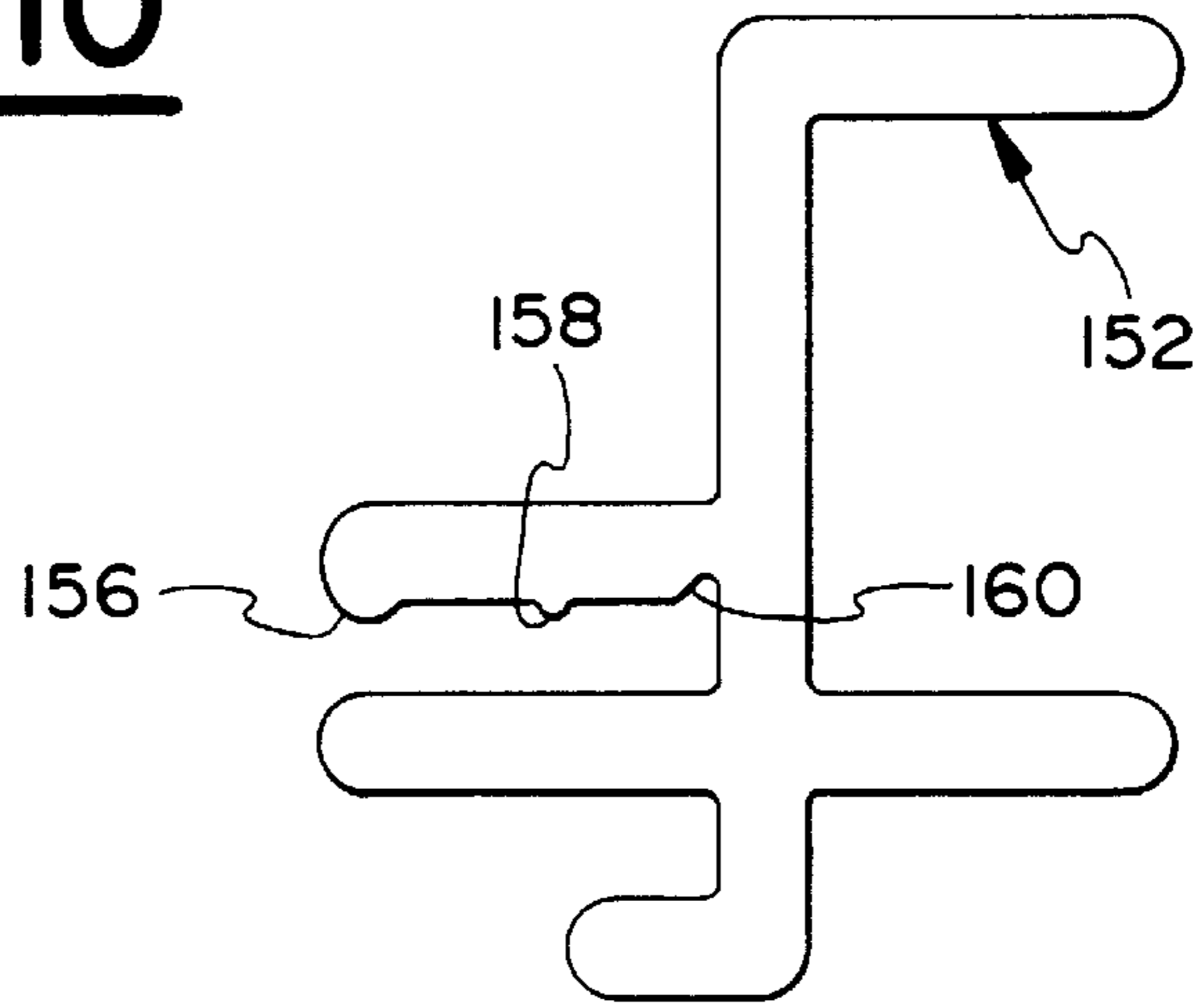

FIG. 11

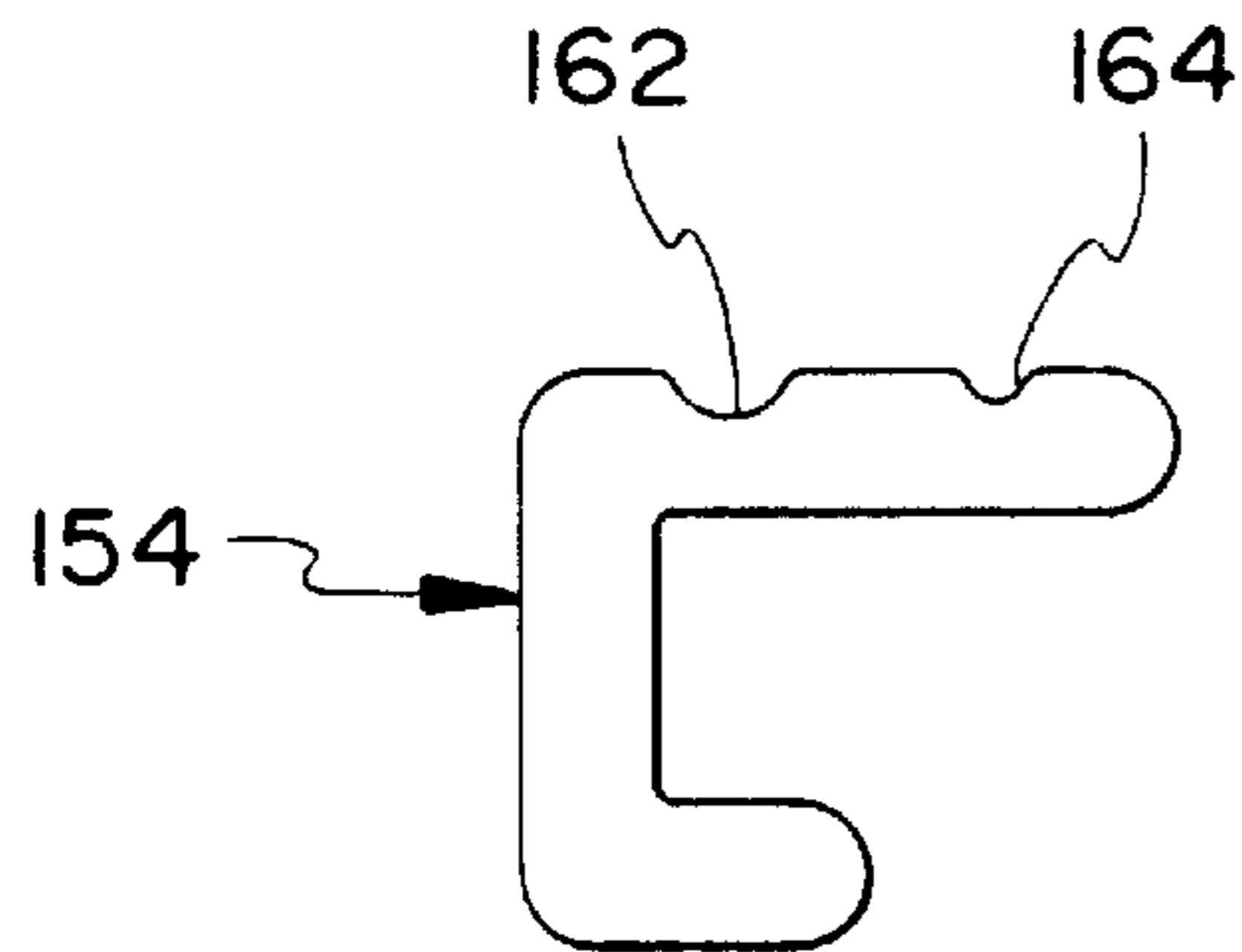

FIG. 12

FIG. 13

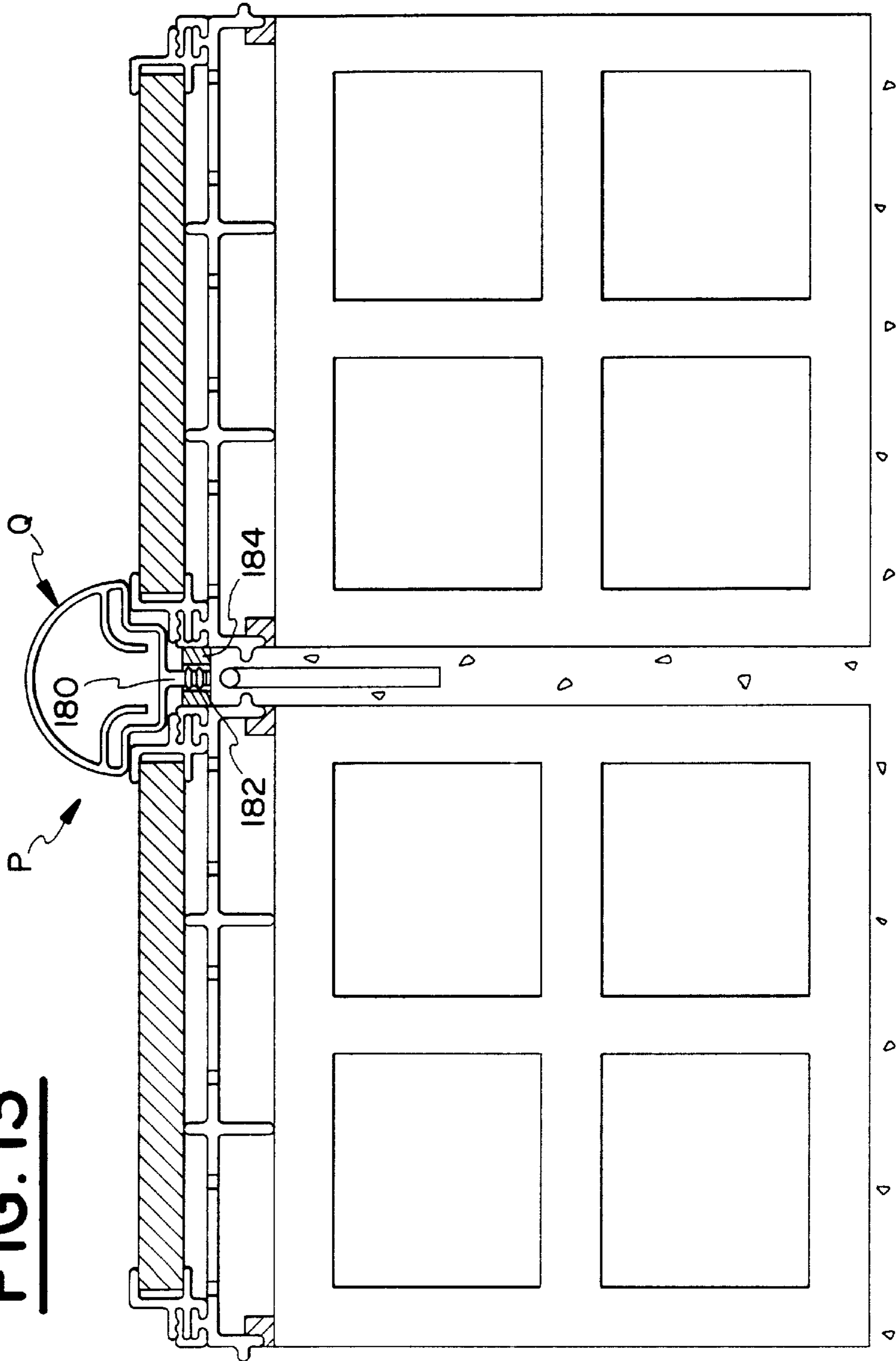
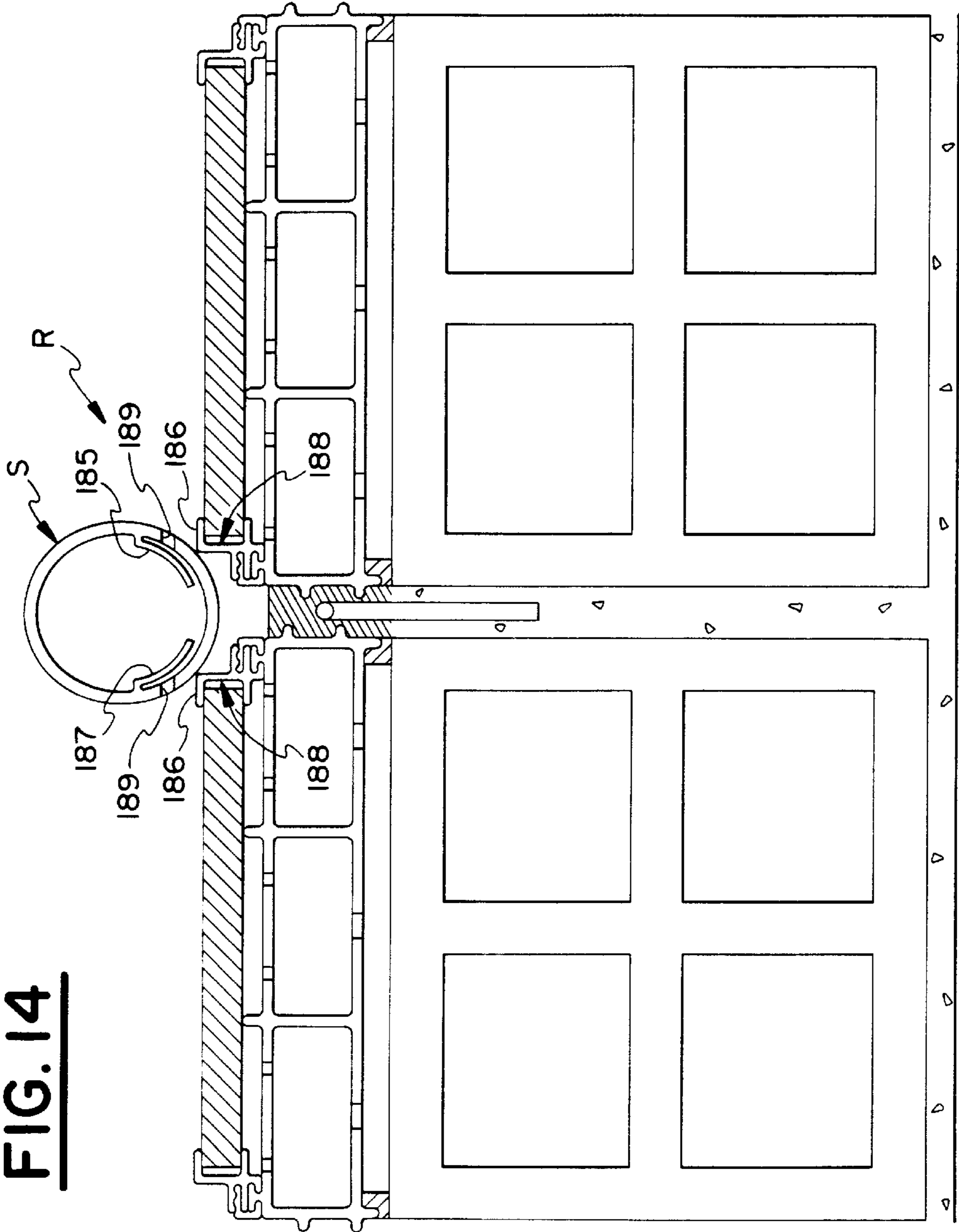

FIG. 14



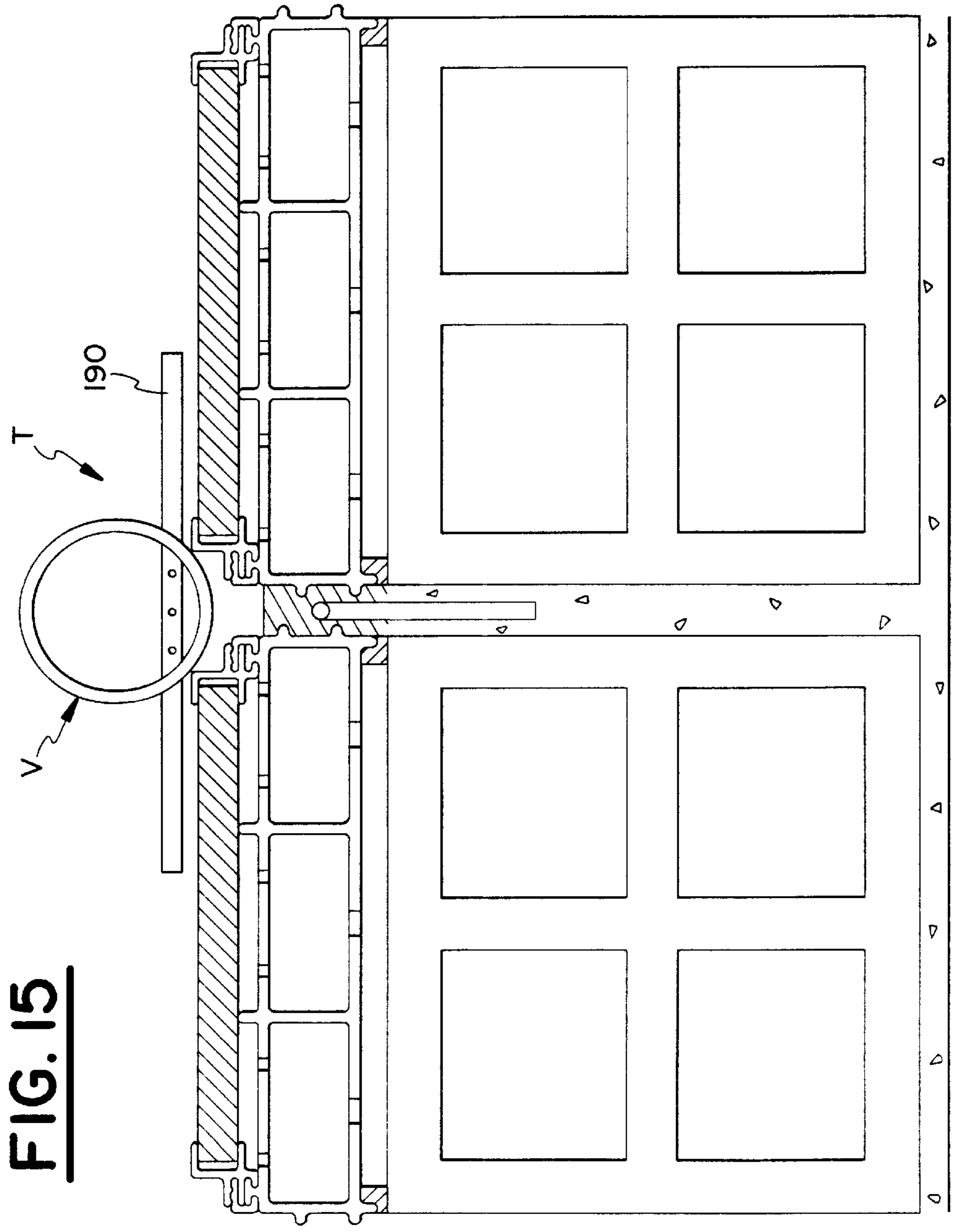
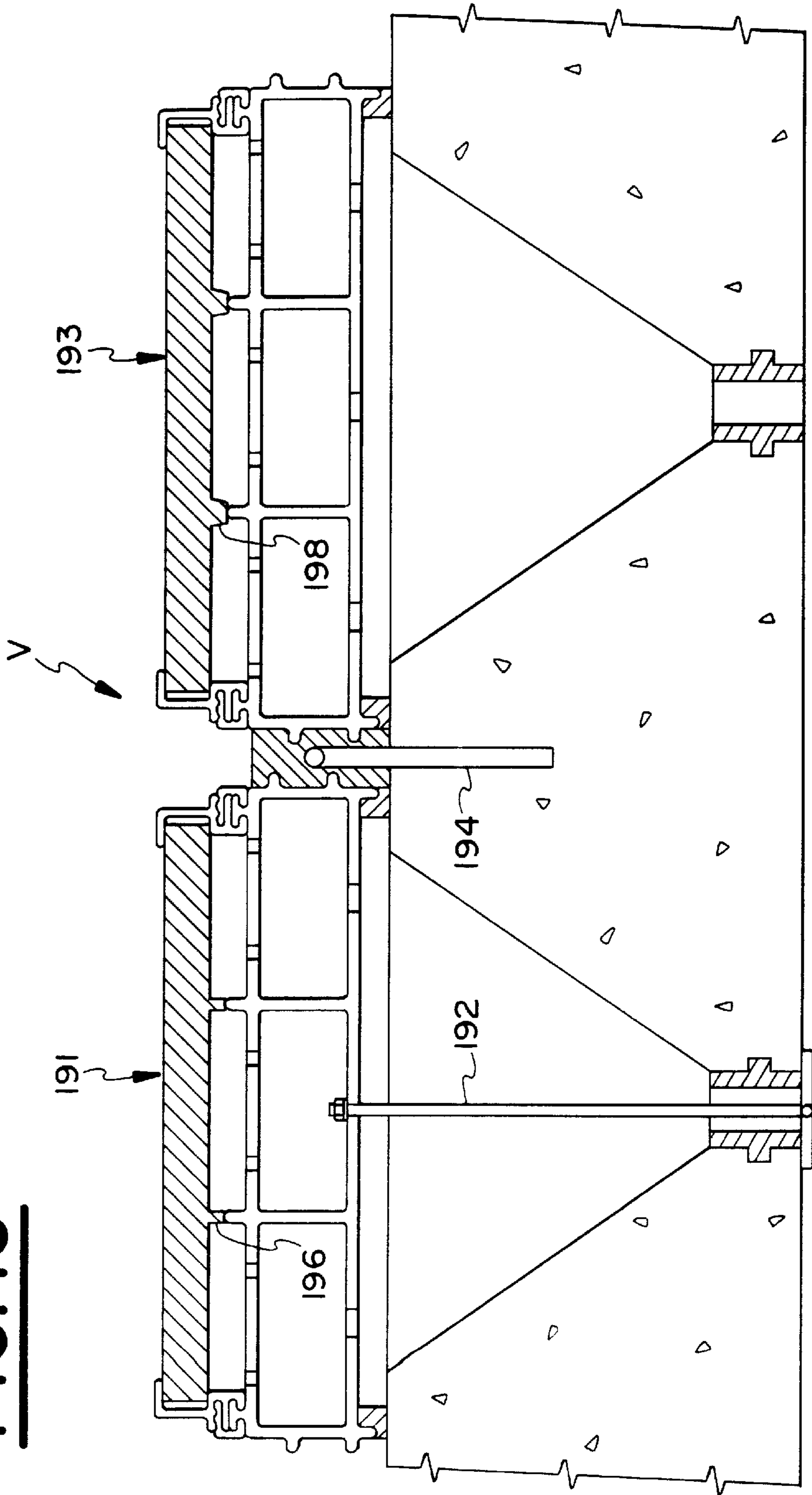

FIG. 15

FIG. 16



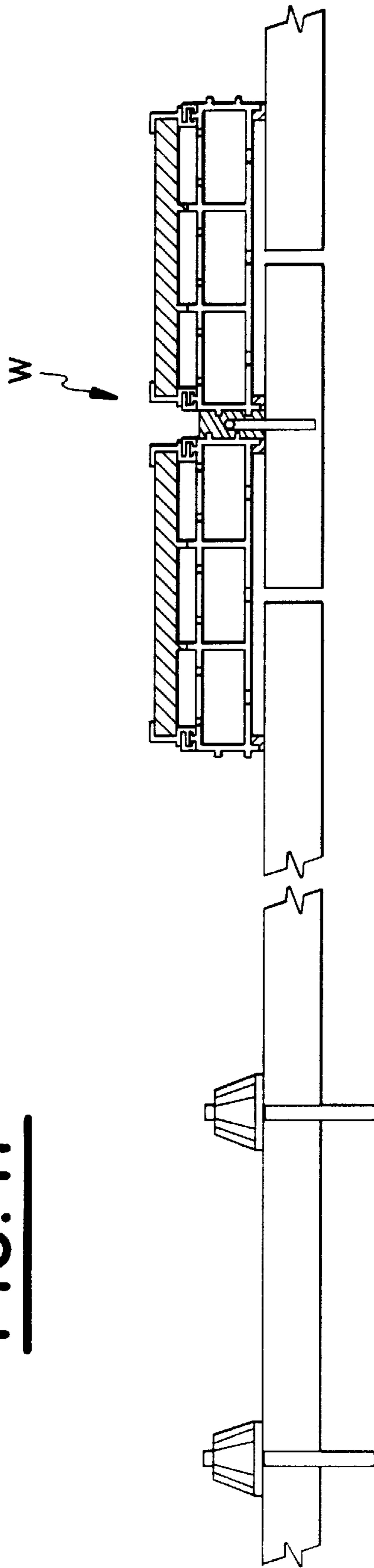

FIG. 17

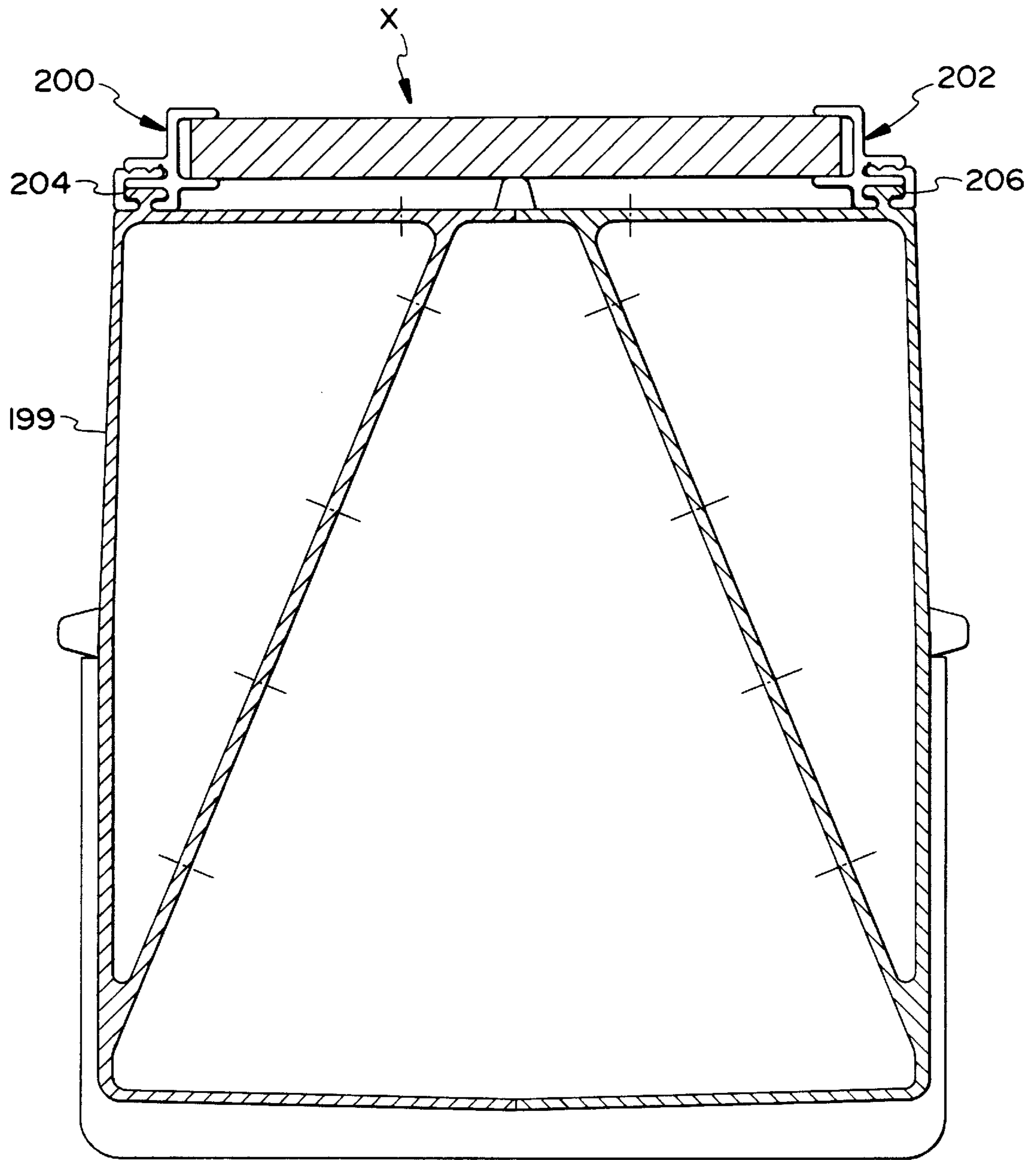
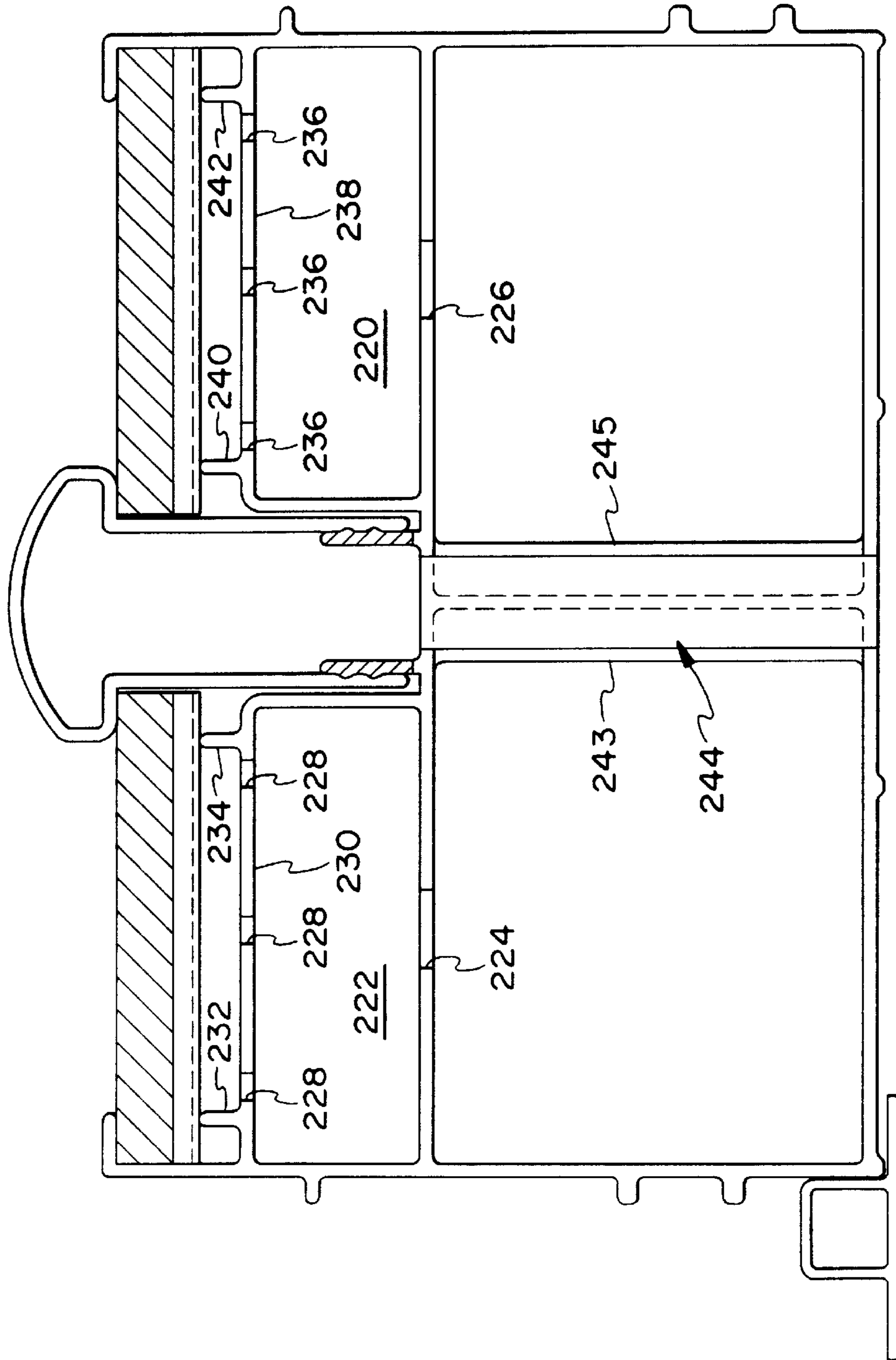

FIG. 18

FIG. 19



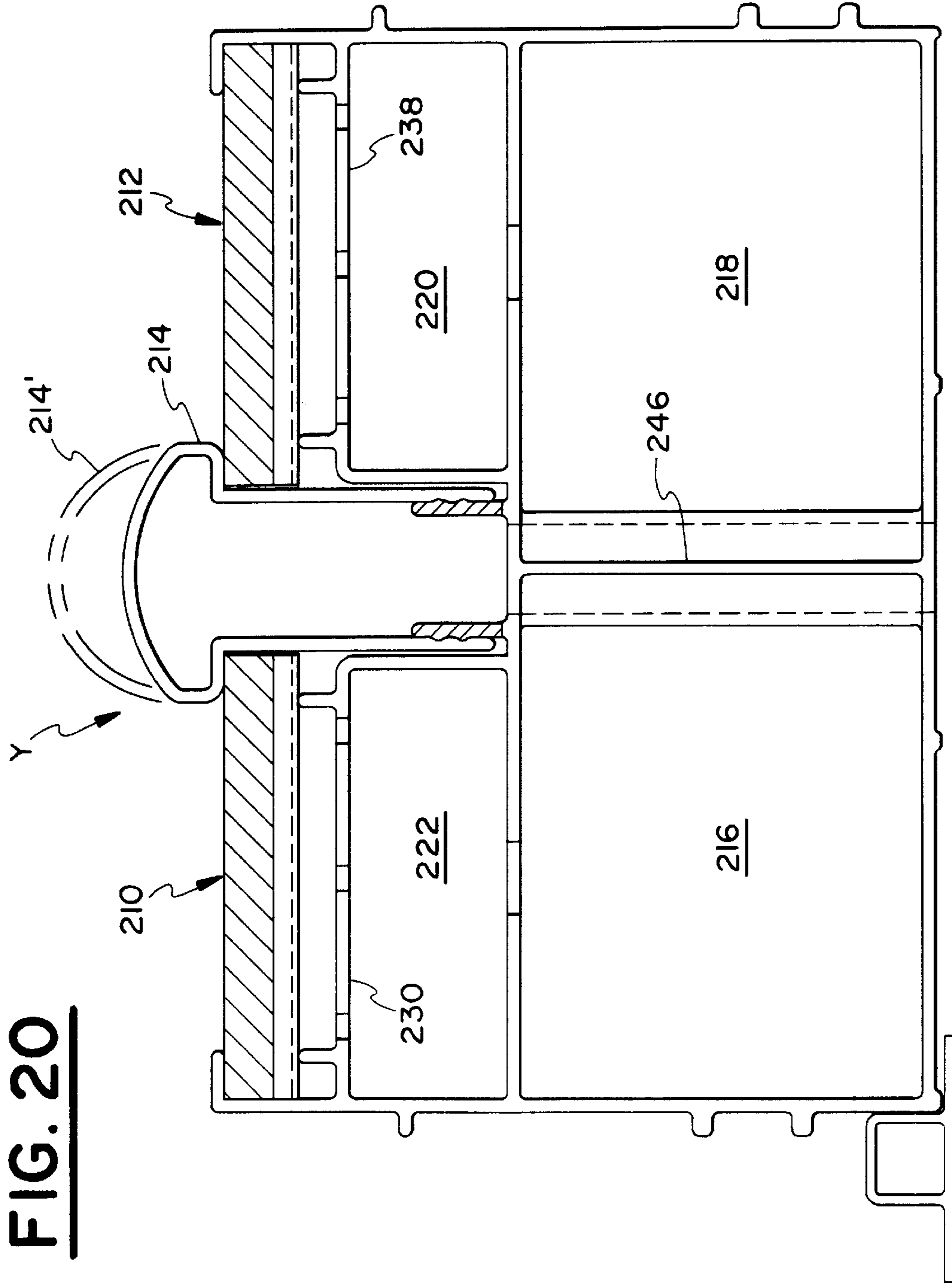
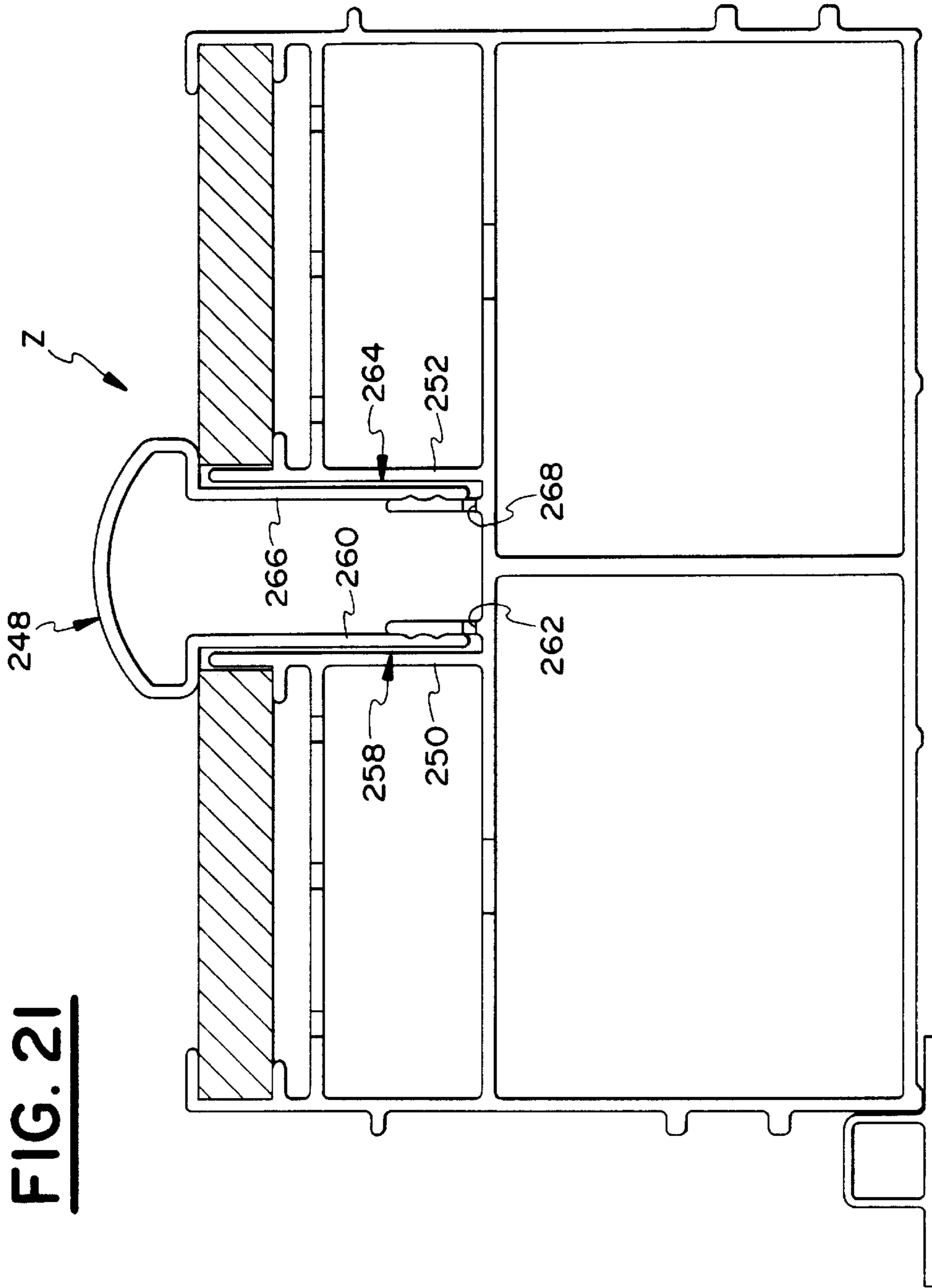

FIG. 20

FIG. 21



APPARATUS FOR DIRECTING FLUIDS THROUGH A FILTER SYSTEM

FIELD OF THE INVENTION

The present invention includes one or more devices for directing fluids (i.e., a liquid and/or a gas) through a filter system for filtering water and/or wastewater. The filter system includes but is not limited to an upflow filter, a downflow filter, a filter system having a combined upflow filter and a downflow filter and/or a filter system having multiple (i.e., more than one) downflow filters connected in series.

BACKGROUND OF THE INVENTION

Various systems have been developed to filter water and wastewater. Typical filter systems include but are not limited to an upflow filter, a downflow filter, a combined upflow filter and a downflow filter and multiple downflow filters connected in series. The term upflow filter is given to a filter in which the liquid or influent to be filtered is directed in an upward path to remove impurities. Conversely, a downflow filter is a filter in which the influent is directed in a downward path to remove impurities. In a combined upflow/downflow filter, influent is directed upwardly through the upflow filter to remove a predetermined percentage of the impurities in the influent and then the influent is directed downwardly through the downflow filter to remove the remaining impurities to within an acceptable limit. In this type of system, it is common for the upflow filter and downflow filter to include one or more layers of filter media supported by one or more gravel support layers. Gravel support layers are necessary for certain filter systems to prevent clogging of the underdrain. For example, one common type of underdrain includes a plurality of underdrain blocks arranged in parallel rows across the bottom of the filter. The underdrain blocks act to direct and receive fluids including influent, effluent and air during operation of the filter system. The underdrain blocks typically include multiple large apertures through which the fluids are directed and received. The apertures are of such a size that the filter media can pass therethrough and clog the underdrain block. This of course is disadvantageous. One solution has been the use of one or more gravel support layers to support the filter media. The gravel is larger than the openings in the underdrain block and, therefore, does not pass therethrough.

However, gravel support layers have a number of disadvantages. Specifically, gravel support layers are expensive and time consuming to install. Further, gravel support layers consume a significant portion of the filter chamber thus reducing the filtering capacity of the bed. Also, gravel support layers are subject to being upset when uncontrolled air enters the filter bed due to improper installation of the air system or operator error. Moreover, in filter beds using granular activated carbon such must occasionally be removed from the filter and placed in a reactivation furnace. During removal of the granular activated carbon, the gravel becomes intermixed and is deposited in the reactivation furnace. At the extreme temperatures necessary to reactivate the granular activated carbon the gravel can explode damaging the furnace.

To overcome the disadvantages of gravel support layers, porous plates have been used with underdrain blocks. The porous plates obviate the need for the gravel support layers because they prevent the filter media from passing through the apertures in the underdrain block. Typically, porous

plates have been fastened directly to the underdrain block with screws or bolts. This conventional means of securing the porous plate to the underdrain block has significant drawbacks. These conventional fasteners increase the cost of the system from both a materials and labor stand point. Further, if the porous plate needs to be replaced a laborer would be required to removal all of the numerous fasteners before such could be accomplished. Moreover, conventional fasteners could damage the porous plate requiring its removal. In addition, a direct connection of the porous plate to the underdrain block without sufficient offset would likely lead to maldistribution of the fluid.

To overcome the disadvantages of prior underdrain systems including but not limited to the disadvantages attendant securing a porous plate to an underdrain block with conventional fasteners Roberts Water Technologies introduced the novel and unobvious INFINITY™ continuous lateral underdrain. This underdrain is prior art to the subject patent application as it was sold or offered for sale more than a year prior to the filing date of the subject patent application. This underdrain is advertised on the World Wide Web at www.robertsfiltergroup.com. While the INFINITY™ underdrain is a significant improvement over previously developed underdrains, the present invention is yet a further substantial improvement over the INFINITY™ underdrain. Specifically, one aspect of the present invention includes a novel and unobvious means for permitting a porous plate to be readily removed from a supporting structure allowing replacement thereof. A significant advantage to this aspect of the invention is that the porous plate can be removed from the supporting structure readily without damaging the major components of the underdrain.

Another significant disadvantage of prior developments is that an existing underdrain could not be satisfactorily retrofitted with a porous plate thereby obviating the need for one or more gravel support layers. Further, prior developments lacked the ability to readily retrofit numerous different types of underdrains with a porous plate to thereby obviate the need for one or more gravel support layers.

Prior fluid distribution systems included means for distributing air to a filter bed having one or more layers of media during washing of the filter bed. This is commonly referred to as air scouring. Air scouring has been determined to be an important process in cleaning filter beds. A number of existing underdrain systems are designed such that liquids and gases flow through common conduits. Such underdrain systems have significant drawbacks. Specifically, because of the conflict between the flow rates of liquids and gases, upper limits must unnecessarily be imposed minimizing the flexibility in setting different ranges of flow rates for liquids and gases. Further, common discharge passages for liquids and gases result in uneven discharge of the air bubbles resulting in undesirable maldistribution. To overcome the disadvantages of prior underdrain systems including but not limited to the disadvantages attendant common liquid and gas conduits, Roberts Water Technologies introduced the novel and unobvious ARIES® managed air systems. This managed air system is advertised on the World Wide Web at www.robertsfiltergroup.com. and disclosed in U.S. Pat. Nos. 5,535,202 and 5,673,481. While the ARIES® managed air system is a significant improvement over previously developed air scour systems, the present invention is yet a further substantial improvement as will be readily recognized by those skilled in the art.

Some previously known air scour systems have also suffered from the disadvantage of maldistribution owing to incomplete evacuation of water from the air conduit. The

problem of incomplete evacuation of water is often experienced where the air conduit has not been installed correctly. One example, is an unlevel installation of the air conduit. In such circumstances, the exit or discharge openings on the low side of the air conduit often remain blocked by water preventing proper distribution of air to the filter bed to adequately clean the same.

Previously known combined air and liquid distribution systems utilizing shared conduits have experienced uncontrolled releases of air which can lead to significant problems. Specifically, systems using shared conduits are likely to experience rapid introduction of air or water flow. This rapid introduction of flow can create a wave action resulting in fluctuation of the interfaces which can expose the water metering orifices to air flow resulting in gross maldistribution.

OBJECTS AND SUMMARY OF THE INVENTION

An object of the present invention is to provide a novel and unobvious fluid distribution system.

Another object of a preferred embodiment of the present invention is to provide a fluid distribution system which obviates the need for one or more gravel support layers.

A further object of a preferred embodiment of the present invention is to provide a fluid distribution system which retains a porous plate without the use of conventional fasteners such as screws and bolts.

Still a further object of a preferred embodiment of the present invention is to provide a fluid distribution system which permits ready removal of a porous plate for replacement without damaging the major components of the fluid distribution system.

Yet still a further object of a preferred embodiment of the present invention is to provide a fluid distribution system which does not suffer from maldistribution of liquids and/or gases.

Another object of a preferred embodiment of the present invention is to provide a fluid distribution system which permits upgrading an existing underdrain system to allow removal of one or more gravel support layers without removing the existing underdrain structure.

A further object of a preferred embodiment of the present invention is to provide a fluid distribution system which can be readily used in conjunction with numerous different exiting underdrains to permit removal of one or more gravel support layers.

Still another object of a preferred embodiment of the present invention is to provide a fluid distribution system which provides for separate liquid and gas distribution conduits.

Still a further object of a preferred embodiment of the present invention is to provide a fluid distribution system that permits an air conduit to be readily attached to an underdrain.

Yet another object of the present invention is to provide a fluid distribution system which includes an air conduit having means for facilitating evacuation of water from the air conduit.

It must be understood that no one embodiment of the present invention need include all of the aforementioned objects of the present invention. Rather, a given embodiment may include one or none of the aforementioned objects. Accordingly, these objects are not to be used to limit the scope of the claims of the present invention.

In summary, one embodiment of the present invention is an apparatus for use in a filter system for filtering water or wastewater. The apparatus includes an underdrain. The underdrain has at least one chamber. The apparatus further includes a porous plate and at least one support member for supporting the porous plate in fixed relationship relative to the at least one chamber. The support member includes a weakness point or other means for permitting ready removal of the porous plate. Another embodiment of the present invention is a method of enhancing an existing underdrain of a filter system for filtering water or wastewater. The method includes the steps of providing an existing underdrain; providing an underdrain cap having a support member for supporting or receiving a porous plate; securing the underdrain cap to the existing underdrain; and, providing at least one porous plate to obviate the need for one or more media support layers.

A further embodiment of the present invention is an apparatus for use in a filter system for filtering water or wastewater. The apparatus includes an underdrain; an underdrain cap secured to the underdrain; and, an air distribution conduit detachably connected to the underdrain cap. Still another embodiment of the present invention is an apparatus for use in filter systems for filtering water or wastewater. The apparatus includes at least one underdrain block and an air conduit detachably connected to the underdrain block. Still another embodiment of the present invention is an apparatus for use in a filter system for filtering water or wastewater. The apparatus includes an underdrain and an underdrain cap secured to the underdrain. The underdrain cap includes a recess or other means for receiving a porous plate.

Still a further embodiment of the present invention is an apparatus for use in a filter system for filtering water or wastewater. The apparatus includes at least one liquid distribution chamber and at least one air distribution conduit. The apparatus further includes a porous plate. The at least one air distribution conduit includes an exit opening disposed such that air exits the air conduit below the porous plate.

Yet another embodiment of the present invention is an apparatus for use in a filter system for filtering water or wastewater. The apparatus includes at least one liquid distribution chamber and at least one distribution conduit. The air distribution conduit includes an internal flange or other means for facilitating evacuation of water from the air distribution conduit. Yet a further embodiment of the present invention is an apparatus for use in a filter system for filtering water or wastewater. The apparatus includes at least one liquid distribution chamber and at least one air distribution conduit. The apparatus further includes a porous plate. The liquid distribution chamber is disposed entirely below the porous plate. The at least one air distribution conduit includes upper and lower portions. The upper portion is located above the porous plate while the lower portion is located below the porous plate.

BRIEF DESCRIPTION OF THE DRAWINGS

FIG. 1 is a cross-sectional view of a first preferred embodiment of the present invention depicting two of multiple possible variations thereof.

FIG. 2 is a cross-sectional view of one of the two possible variations depicted in FIG. 1.

FIG. 3 is a cross-sectional view taken along lines 3—3 in FIG. 2.

FIG. 4 is a perspective view of the variation of the first preferred embodiment depicted on the left side of FIG. 1.

5

FIG. 5 is a cross-sectional view of two of multiple possible variations of the first preferred embodiment of the present invention one of which is depicted in FIG. 1 the other of which is not depicted in any of the previous drawings.

FIG. 6 is a cross-sectional view of a second preferred embodiment of the present invention.

FIG. 7 is a cross-sectional view of a portion of the second preferred embodiment depicted in FIG. 6.

FIG. 8 is a cross-sectional view of one of the elements depicted in FIG. 7.

FIG. 9 is a cross-sectional view of one of the elements depicted in FIG. 7.

FIG. 10 is a cross-sectional view of one of multiple possible variations of the portion of the second preferred embodiment illustrated in FIG. 7.

FIG. 11 is a cross-sectional view of one of the elements depicted in FIG. 10.

FIG. 12 is a cross-sectional view of one of the elements depicted in FIG. 10.

FIG. 13 is a cross-sectional view of a third preferred embodiment of the present invention.

FIG. 14 is a cross-sectional view of a fourth preferred embodiment of the present invention.

FIG. 15 is a cross-sectional view of a fifth preferred embodiment of the present invention.

FIG. 16 is a cross-sectional view of a sixth preferred embodiment of the present invention.

FIG. 17 is a cross-sectional view of a seventh preferred embodiment of the present invention.

FIG. 18 is a cross-sectional view of an eighth preferred embodiment of the present invention.

FIG. 19 is a cross-sectional view of a ninth preferred embodiment of the present invention.

FIG. 20 is a cross-sectional view taken along a different section of the ninth preferred embodiment of the present invention.

FIG. 21 is a cross-sectional view of a tenth preferred embodiment of the present invention.

DETAILED DESCRIPTION OF THE PREFERRED EMBODIMENTS OF THE INVENTION

The preferred forms of the invention will now be described with reference to FIGS. 1–21. The appended claims are not limited to the preferred embodiments and no term used herein is to be given a meaning other than its ordinary meaning unless accompanied by a statement that the term “as used herein is defined as follows”.

FIGS. 1 Through 4

Referring to FIGS. 1 through 4, a fluid distribution system A is depicted. The fluid distribution system includes an existing underdrain B, a pair of underdrain caps C and D and a pair of air conduits E and F. An air supply connection G is secured to the air distribution conduit E in a fluid tight manner. An air supply connection H is secured to the air distribution conduit F in a fluid tight manner.

The existing underdrain includes a plurality of rows of underdrain blocks which are positioned on or adjacent the bottom of the filter. Only two rows are depicted in FIG. 1. The first row 2 of clay tile underdrain blocks are disposed beneath the underdrain cap C. The rows are formed by

6

multiple underdrain blocks positioned in end to end relationship. As is conventional, the upper surface 4 of each of the clay tile underdrain blocks includes a plurality of openings (not shown) through which fluid can pass. Each underdrain block in the first row 2 includes four (4) chambers or conduits 6, 8, 10 and 12. Openings (not shown) are provided in the underdrain blocks so that chamber 10 communicates with chamber 6 and chamber 12 communicates with chamber 8. The second row 14 of clay tile underdrain blocks are configured in a manner similar to the underdrain blocks in the first row 2 and, therefore, these underdrain blocks will not be described in detail.

The underdrain cap C is secured and sealed to the clay tile underdrain blocks via grout 16. However, it will be readily appreciated that any suitable material may be used to secure and seal the underdrain cap C to the underdrain blocks including but not limited to elastomeric sealants. Preferably, the underdrain cap C is extruded in continuous lengths from high impact corrosion resistant PVC. Hence, the underdrain cap C preferably runs substantially the length of the row of underdrain blocks. However, it will be readily appreciated that the underdrain cap C could be formed from any suitable material. Further, the underdrain cap C may be sized such that multiple segments are positioned end to end to extend the substantially the length of the row of underdrain blocks. While the underdrain cap C is shown as running along (i.e., parallel to) the underdrain blocks, it will be readily appreciated that such could be oriented perpendicular to the underdrain blocks.

Referring to FIGS. 1 and 4, the underdrain cap C forms two conduits or chambers 18 and 20. Chamber 18 communicates with chamber 6 via the opening in the upper surface 4 of the underdrain blocks. Similarly, the chamber 20 communicates with the chamber 8 via the openings in the upper surface 4 of the underdrain blocks. While two chambers are shown as being formed by the underdrain cap C, it will be readily appreciated that the underdrain cap C may be configured such that one or more than two chambers are formed. The underdrain cap C preferably includes a pair of horizontal walls 22 and 24 extending outwardly from recessed portion 26. Walls 22 and 24 are provided with the appropriate number of discharge openings or orifices 28 to assure that the liquid flowing from the clay tile underdrain blocks is properly distributed throughout the filter bed. When this embodiment of the present invention is used in an upflow filter, chambers 18 and 20 assure that the influent to be filtered will be uniformly discharged into the filter bed in the case of an upflow filter. Further, when used in an upflow filter these chambers assure that the backwash liquid which may be either influent or filtered water will be uniformly discharged into the filter bed. Similarly, when the present invention is used in a downflow filter, chambers 18 and 20 assure that the filtered water will be uniformly collected and that the backwash liquid will be uniformly discharged into the filter bed. This is a significant improvement of prior devices which mounted a porous plate directly to an underdrain block without any type of underdrain cap therebetween.

The underdrain cap C further includes a pair of vertically oriented support members 30 and 32. Support member 30 includes a pair of horizontally extending elements 36 and 38. Elements 36 and 38 form a recess 40 for receiving a portion of porous plate 42. Vertically oriented wall 43 supports the opposite end of porous plate 42. Similarly, support member 32 includes a pair of horizontally extending elements 44 and 46. Elements 44 and 46 form a recess 48 for receiving a portion of porous plate 50. Vertically oriented wall 52 supports the opposite end of porous plate 50.

The air conduit E is snap fit onto the underdrain cap C. Specifically, the air conduit E has a pair of vertically extending walls **54** and **56**. Each of the walls **54** and **56** have a pair of recesses **58**. A pair of walls **60** and **62** extend upwardly from the bottom of recess **26**. The walls **60** and **62** each include a pair of protrusions **64** for engaging the recesses formed in the corresponding walls of air conduit E. This configuration permits the air conduit to be readily snap fit onto the underdrain cap C. It will be readily appreciated that various other configurations could be used to snap fit the air conduit onto the underdrain. In this regard, it is noted that while walls **60** and **62** are depicted as being on the inside of the corresponding walls **54** and **56** such orientation can be reversed. Air conduit E includes a pair of shoulders **66** and **68**. Shoulder **66** aids in securing porous plate **42** in fixed relationship relative to the underdrain blocks. Similarly, shoulder **68** aids in securing porous plate **50** in fixed relationship relative to the underdrain blocks. It will be readily appreciated that porous plates **42** and **50** are held in fixed relationship relative to the underdrain block without the use of screws or bolts.

Referring to FIG. 3, porous plate **50** has a plurality of grooves **70** formed therein. It should be noted that while FIG. 3 depicts porous plate **50**, porous plate **42** is configured in an identical manner. A channel **72** is disposed in each of the grooves **70**. The channels **72** ensure proper distribution of air or other gas along the width of the porous plates **42** and **50**. It will be noted that the ends of the porous plates **42** and **50** adjacent the air conduit E are spaced from walls **54** and **56**. This spacing permits air or other gas to enter the channels **72**.

The preferred embodiment depicted in FIGS. 1 through 4 prevents the mixing of gas or liquids in chambers **18** and **20**.

Rebar hook anchor **74** is disposed in the grout between the underdrain blocks to enhance securement of the underdrain caps C and D.

Referring to FIG. 2, underdrain cap D depicts one of many possible variations to the underdrain cap C. Underdrain cap D is similar to underdrain cap C, therefore, only the differences will be explained in detail. Vertically oriented walls **76** and **78** have horizontally extending elements **80** and **82**, respectively. Further, vertically extending elements **84** and **86** are disposed adjacent elements **80** and **82**, respectively. Elements **80** and **84** form a recess to receive one end of porous plate **88**. Similarly, elements **82** and **86** form a recess to receive one end of the porous plate **90**. Unlike porous plates **42** and **50**, porous plates **88** and **90** directly abut the air conduit F. Metering orifices are provided in the channels adjacent the air conduit F to permit air or other gas to enter the channels and subsequently pass through the corresponding porous plate to the filter bed. It will be readily appreciated that other types of openings other than metering orifices may be used. Air conduit F has a different configuration from air conduit E. As will be appreciated by one of ordinary skill in the art, the air conduits may be configured in numerous different ways. The dashed lines F' illustrates one such possible modification.

FIG. 5

Referring to FIG. 5, a fluid distribution system I is illustrated. Fluid distribution system I is very similar to the fluid distribution system A. Accordingly, only the differences will be described. Specifically, air conduit J has a different configuration than previously illustrated air conduits.

FIGS. 6 Through 9

Referring to FIG. 6, a fluid distribution system K is depicted. The fluid distribution system K includes an exist-

ing underdrain L, a pair of underdrain caps M and N and an air conduits O. An air supply connection (not shown) is secured to the air distribution conduit O in a fluid tight manner to supply air or other gas to the air distribution conduit O. The existing underdrain L is as described in connection with the fluid distribution system A.

The underdrain cap M is secured and sealed to the clay tile underdrain blocks via grout **92**. However, it will be readily appreciated that any suitable material may be used to secure and seal the underdrain cap M to the underdrain blocks including but not limited to elastic sealants. Preferably, the underdrain cap M is extruded in continuous lengths from high impact corrosion resistant PVC. Hence, the underdrain cap M preferably runs substantially the length of the row of underdrain blocks. However, it will be readily appreciated that the underdrain cap M could be formed from any suitable material. Further, the underdrain cap M may be sized such that multiple segments are positioned end to end to extend substantially the length of the row of underdrain blocks.

The underdrain cap M forms four conduits or chambers **94**, **96**, **98** and **100**. Chamber **94** communicates with the chambers in the underdrain blocks via the openings formed in the upper surface of the underdrain blocks. Chambers **96**, **98** and **100** communicate with chamber **94** via a plurality of openings **101** formed in horizontally extending wall **102**. The underdrain cap M includes a horizontal wall **104** which extends substantially parallel to wall **102**. A plurality of openings **103** are formed in wall **104** to permit fluid to pass from chambers **96**, **98** and **100** upwardly through porous plate **106**. A pair of elements **108** and **110** extend upwardly from wall **104** to support the mid-section of porous plate **106**. End rails **112** and **114** extend along opposite sides of the wall **104**. Porous plate support members **116** and **118** are connected to end rails **112** and **114**, respectively. Support members **116** and **118** are configured in a similar manner. Accordingly, only support member **116** will be described in detail.

Referring to FIGS. 7 through 9, support member **116** includes two separate elements **120** and **122**. Element **120** includes a vertical segment **124**. The vertical segment **124** includes inner surface **126** and outer surface **128**. A pair of members **130** and **132** extend inwardly from the inner surface **126**. Members **130** and **132** form a recess for receiving a portion of porous plate **106** as is readily seen in FIG. 6. Members **134**, **136** and **138** extend outwardly from the outer surface **128**. Members **134** and **136** receive a portion of end rail **112**. Member **138** has a pair of protrusions **140** and **142** as well as a weakness point **144**. While weakness point **144** is illustrated as a V-shaped notch, it will be readily appreciated that the weakness point **144** can take many different forms. Further, it will be readily appreciated that the weakness point can be formed in a variety of different ways. Weakness point **144** allows removal of the porous plate **106** without damage to any major component of the underdrain cap M. Specifically, one need only cut member **138** along the weakness point **144** to readily detach the porous plate support member **120** from the porous plate **106**. In this manner, the porous plate can be readily replaced.

Element **122** is substantially L-shaped and receives a portion of the end rail **112** as seen in FIG. 7. Element **122** includes a pair of v-shaped notches **146** and **148** which receive protrusions **140** and **142**, respectively. Referring to FIGS. 10 through 12, an alternative form of porous plate support member is illustrated. The porous plate support member **150** includes two separate elements **152** and **154**. Element **152** differs from element **120** in that the protrusions **156** and **158** as well as the weakness point **160** are shaped

differently. Element **154** differs from element **122** in that the recesses **162** and **164** are shaped differently.

Referring again to FIG. 6, the underdrain cap N is formed in a similar manner to underdrain cap M and, therefore, will not be described in detail. Air distribution conduit O is snapped onto pin **166**. Pin **166** is epoxied into grout **168** or other suitable material. Rebar hook anchor **170** is provided to enhance securement of the underdrain caps M and N to the underdrain blocks.

Air distribution conduit O includes a plurality of water evacuation openings **172** and a plurality of air distribution orifices **174**. Internal flanges **176** and **178** facilitate the evacuation of water from the air distribution conduit O.

Referring to FIG. 13, fluid distribution system P is similar to fluid distribution system K depicted in FIG. 6. Accordingly, only the differences will be explained in detail. System P includes an air conduit Q. Air conduit Q has a pin **180** formed as one piece therewith. A corresponding thin female element **182** is epoxied into the grout **184** or other suitable material. The pin **180** is snapped into female element **182**.

FIGS. 14 and 15

Referring to FIG. 14, a fluid distribution system R similar to fluid distribution system K is depicted. Accordingly, only the differences will be described in detail. Specifically, the fluid distribution system R includes an air distribution conduit S. The air distribution S conduit is secured to or alternatively formed as one piece with elements **186** of porous plate support members **188**. Air conduit S includes two internal flanges **185** and **187** which facilitate discharge of water through the water evacuation openings **189**. Similarly, FIG. 15 depicts a fluid distribution system T that utilizes another alternative air distribution conduit U. A plurality of laterals **190** extend outwardly from the air distribution conduit U. The laterals **190** have a plurality of openings (not shown) to discharge air into the filter bed during air scouring. Air distribution conduit U is secured in a similar manner to air distribution conduit S.

FIGS. 16 Through 18

Referring to FIG. 16, fluid distribution system V is similar to the fluid distribution system K with the exceptions that the air conduit has been omitted and the existing underdrain is a monolithic wheeler bottom. In addition, a toggle bolt **192** may be used with or in place of the rebar hook anchor **194**. Further, porous plates **191** and **193** may be provided with protrusions **196** or **198** to provide additional support for the mid-section of the plates. Referring to FIG. 17, a fluid distribution system W, similar to fluid distribution system V, is being installed over an existing nozzle underdrain. Referring to FIG. 18, a fluid distribution system X is mounted on a Trilateral air/water underdrain **199** via porous plate support members **200** and **202**. Support members **200** and **202** are connected to end rails **204** and **206**, respectively. Preferably, end rails **204** and **206** are formed as one piece with the Trilateral air/water underdrain **199**. Support members **200** and **202** are similar to support member **116** depicted in FIG. 6, and, therefore will not be described in detail.

FIGS. 19 Through 21

Referring to FIGS. 19 and 20, fluid distribution system Y includes a one-piece underdrain **208**, porous plates **210** and **212** and air distribution conduit **214**. Porous plates **210** and **212** are similar to porous plates **42** and **50**. Underdrain **208**

includes fluid chambers **216**, **218**, **220** and **222**. Chamber **216** communicates with chamber **222** via a plurality of openings **224** (only one of which is shown). Similarly, chamber **218** communicates with chamber **220** via a plurality of openings **226** (only one of which is shown). Openings **228** are formed in upper wall **230** to permit fluids to pass upwardly through porous plate **210**. Support walls **232** and **234** extend upwardly from upper wall **230** to provide additional support for porous plate **210**. Openings **236** are formed in upper wall **238** to permit fluids to pass upwardly through porous plate **212**. Support walls **240** and **242** extend upwardly from upper wall **238** to provide additional support for porous plate **212**.

Underdrain **208** includes a plurality of air passageways **244** uniformly spaced along its longitudinal axis. The left and right sides of air passageways **244** are bounded by support walls **243** and **245**, respectively. Support walls provide internal support for the underdrain **208**. Air passageways **244** are connected to air distribution conduit **214**. An air supply source is connected to the air passageways **244** to direct air to air conduit **214**. Referring to FIG. 20, the underdrain includes vertical support walls **246**. The vertical support walls **246** are positioned intermediate adjacent air passageways **244** and provide additional internal support.

Air conduit **214** is similar to air conduits E and F and, therefore, will not be described in detail. Dashed line **214'** illustrates another possible variation of the air conduit. It should also be noted that the air conduit could be formed as one piece with the underdrain or underdrain cap.

Referring to FIG. 21, fluid distribution system Z is similar to fluid distribution system Y and, therefore, only the significant differences will be described. Air is supplied to air conduit **248** in a manner similar to that depicted in FIG. 1. Accordingly, the fluid distribution system Z does not include internal air passageways that are utilized in fluid distribution system Y. The one-piece underdrain includes support members **250** and **252** for supporting corresponding ends of the porous plates **254** and **256**.

An air channel **258** is formed between support member **250** and wall **260** of air conduit **248**. Air channel **258** extends upwardly along the air conduit **248** and allows air discharged from the air conduit **248** via opening **262** to be released into the filter bed during the step of air scouring the bed to clean the same. Similarly, an air channel **264** is formed between support member **252** and wall **266** of air conduit **248**. Air channel **264** extends upwardly along the air conduit **248** and allows air discharged from the air conduit **248** via opening **268** to be released into the filter bed during the step of air scouring the bed to clean the same.

While this invention has been described as having preferred designs, it is understood that it is capable of further modifications, uses and/or adaptations of the invention following in general the principle of the invention and including such departures from the present invention as come within the known customary practice in the art to which the invention pertains and as may be applied to the central features hereinbefore set forth, and fall within the scope of the invention and the limits of the appended claims.

We claim:

1. An apparatus for use in a filter system for filtering water or wastewater, said apparatus comprising:

- (a) an underdrain;
- (b) an underdrain cap for retrofitting said underdrain with at least one porous plate, said underdrain cap being a separate piece from said underdrain and the at least one porous plate, said underdrain cap further being secured to said underdrain;

11

- (c) an air distribution conduit detachably connected to said underdrain cap, said air distribution conduit having at least one shoulder for securing said at least one porous plate to said underdrain; and,
- (d) at least one porous plate.
2. An apparatus as set forth in claim 1, wherein:
- (a) said underdrain includes an underdrain block, said underdrain cap is secured to said underdrain block.
3. An apparatus as set forth in claim 2, further including: first and second porous plates, said air distribution conduit having first and second shoulders for securing said first and second porous plates to said underdrain block.
4. An apparatus for use in a filter system for filtering water or wastewater, said apparatus comprising:
- (a) an underdrain;
- (b) an underdrain cap for retrofitting said underdrain with at least one porous plate, said underdrain cap being a separate piece from said underdrain and the at least one porous plate, said underdrain cap further being secured to said underdrain;
- (c) an air distribution conduit detachably connected to said underdrain cap;
- (d) at least one porous plate; and,
- (e) said air distribution conduit having upper and lower portions, said upper portion of said air distribution conduit being disposed above said at least one porous plate, said lower portion of said air distribution conduit being disposed below said porous plate.
5. An apparatus for use in a filter system for filtering water or wastewater, said apparatus comprising:
- (a) an underdrain;
- (b) an underdrain cap for retrofitting said underdrain with at least one porous plate, said underdrain cap being a separate piece from said underdrain and the at least one porous plate, said underdrain cap further being secured to said underdrain;
- (c) an air distribution conduit detachably connected to said underdrain cap;
- (d) at least one porous plate; and,
- (e) said air distribution conduit having an exit opening where air exits the at least one air distribution conduit, said at least one exit opening is disposed below said porous plate.
6. An apparatus as set forth in claim 5, wherein:
- (a) at least a portion of said air distribution conduit extends above said at least one porous plate.
7. An apparatus for use in a filter system for filtering water or wastewater; said apparatus comprising:
- (a) an underdrain;
- (b) an underdrain cap secured to said underdrain, at least one fluid distribution chamber being formed between said underdrain and said underdrain cap, said underdrain cap having means for receiving at least one porous plate;
- (c) an air distribution conduit snap fit onto said underdrain cap; and,
- (d) a porous plate, said air distribution conduit having at least one shoulder for securing said porous plate to said underdrain cap.

12

8. An apparatus as set forth in claim 7, wherein:
- (a) said underdrain includes a plurality of underdrain blocks, said plurality of underdrain blocks each having at least one fluid distribution chamber.
9. An apparatus as set forth in claim 7, wherein:
- (a) said air distribution conduit has an exit opening where air exits the at least one air distribution conduit, said at least one exit opening is disposed below said porous plate.
10. An apparatus as set forth in claim 7, wherein:
- (a) said air distribution conduit has upper and lower portions, said upper portion of said air distribution conduit being disposed above said at least one porous plate, said lower portion of said air distribution conduit being disposed below said porous plate.
11. An apparatus for use in a filter system for filtering water or wastewater; said apparatus comprising:
- (a) at least one liquid distribution chamber;
- (b) at least one air distribution conduit;
- (c) a porous plate, said at least one liquid distribution chamber being disposed entirely below said porous plate;
- (d) at least a portion of said air distribution conduit extends above said porous plate; said air distribution conduit having at least one exit opening where air exits the at least one air distribution conduit, said at least one exit opening is disposed below said porous plate.
12. An apparatus as set forth in claim 11, further including:
- (a) an underdrain block, said liquid distribution chamber being formed in said underdrain block.
13. An apparatus as set forth in claim 12, further including:
- (a) an underdrain cap secured to said underdrain block.
14. An apparatus as set forth in claim 13, wherein:
- (a) said air distribution conduit is snap fit to said underdrain cap.
15. An apparatus for use in a filter system for filtering water or wastewater; said apparatus comprising:
- (a) at least one liquid distribution chamber; and,
- (b) at least one air distribution conduit having upper and lower portions;
- (c) a porous plate, said at least one liquid distribution chamber being disposed entirely below said porous plate; and,
- (d) said upper portion of said air distribution conduit being disposed above said porous plate, said lower portion of said air distribution conduit being disposed below said porous plate.
16. An apparatus as set forth in claim 15, further including:
- (a) an underdrain block, said liquid distribution chamber being formed in said underdrain block.
17. An apparatus as set forth in claim 16, further including:
- (a) an underdrain cap secured to said underdrain block.
18. An apparatus as set forth in claim 17, wherein:
- (a) said air distribution conduit is snap fit to said underdrain cap.