



US006551342B1

(12) **United States Patent**
Shen et al.

(10) **Patent No.:** US 6,551,342 B1
(45) **Date of Patent:** Apr. 22, 2003

- (54) **EMBOLIC FILTER**
- (75) Inventors: **Christopher T. Shen**, Stanford, CA (US); **Olin Palmer**, Mountain View, CA (US)
- (73) Assignee: **Endovascular Technologies, Inc.**, Menlo Park, CA (US)
- (*) Notice: Subject to any disclaimer, the term of this patent is extended or adjusted under 35 U.S.C. 154(b) by 0 days.
- (21) Appl. No.: **09/939,213**
- (22) Filed: **Aug. 24, 2001**
- (51) **Int. Cl.⁷** **A61M 29/00**
- (52) **U.S. Cl.** **606/200**
- (58) **Field of Search** 606/114, 113, 606/127, 159, 200, 198; 623/1.15, 1.16

5,486,183 A	1/1996	Middleman et al.
5,496,330 A	3/1996	Bates et al.
5,509,923 A	4/1996	Middleman et al.
5,549,626 A	8/1996	Miller et al.
5,601,572 A	2/1997	Middleman et al.
5,681,347 A	10/1997	Cathcart et al.
5,695,518 A	12/1997	Laerum
5,709,704 A	1/1998	Nott et al.
5,720,754 A	2/1998	Middleman et al.
5,720,764 A	2/1998	Naderlinger
5,792,156 A	8/1998	Perouse
5,810,874 A	9/1998	Lefebvre
5,820,628 A	10/1998	Middleman et al.
5,895,398 A	4/1999	Wensel et al.
5,902,263 A	5/1999	Patterson et al.
5,904,690 A	5/1999	Middleman et al.
6,053,932 A	4/2000	Daniel et al.
6,168,603 B1	1/2001	Leslie et al.
6,171,327 B1	1/2001	Daniel et al.
6,443,972 B1 *	9/2002	Bosma et al. 606/200

* cited by examiner

Primary Examiner—Kevin T. Truong
(74) *Attorney, Agent, or Firm*—Fulwider Patton Lee & Utecht, LLP

(56) **References Cited**

U.S. PATENT DOCUMENTS

2,943,626 A	7/1960	Dormia
4,347,846 A	9/1982	Dormia
4,611,594 A	9/1986	Grayhack et al.
4,619,246 A	10/1986	Molgaard-Nielsen et al.
4,865,017 A	9/1989	Shinozuka
4,873,978 A	10/1989	Ginsburg
4,969,891 A	11/1990	Gewertz
4,990,156 A	2/1991	Lefebvre
4,998,539 A	3/1991	Delsanti
5,152,777 A	10/1992	Goldberg et al.
5,171,233 A	12/1992	Amplatz et al.
5,192,286 A	3/1993	Phan et al.
5,234,458 A	8/1993	Metais
5,330,482 A	7/1994	Gibbs et al.
5,383,887 A	1/1995	Nadal

(57) **ABSTRACT**

An intravascular filter device for use in capturing debris which may occur as a result of an intravascular procedure. The filter device includes a proximal section, a distal section and a mid-section. The mid-section includes three rings configured in a sixteen apices alternating V-pattern. The filter device specifically embodies structure that provides enhanced radial opening and angular resistance to collapse in its expanded state. While, in its compressed state the filter device provides an extremely small compressed profile giving it the desired ability to be delivered into very small vessels of the human vasculature.

30 Claims, 7 Drawing Sheets

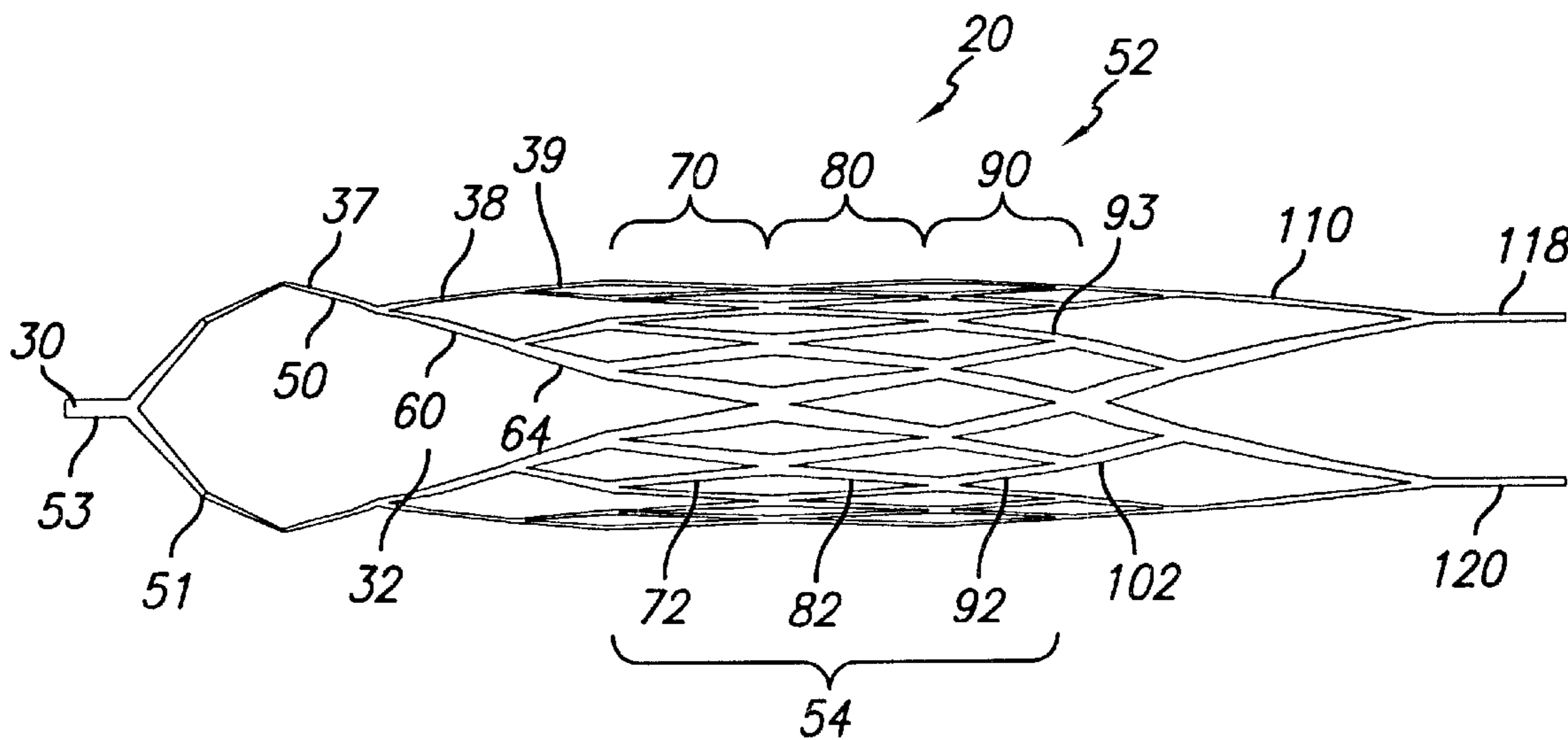

FIG. 1

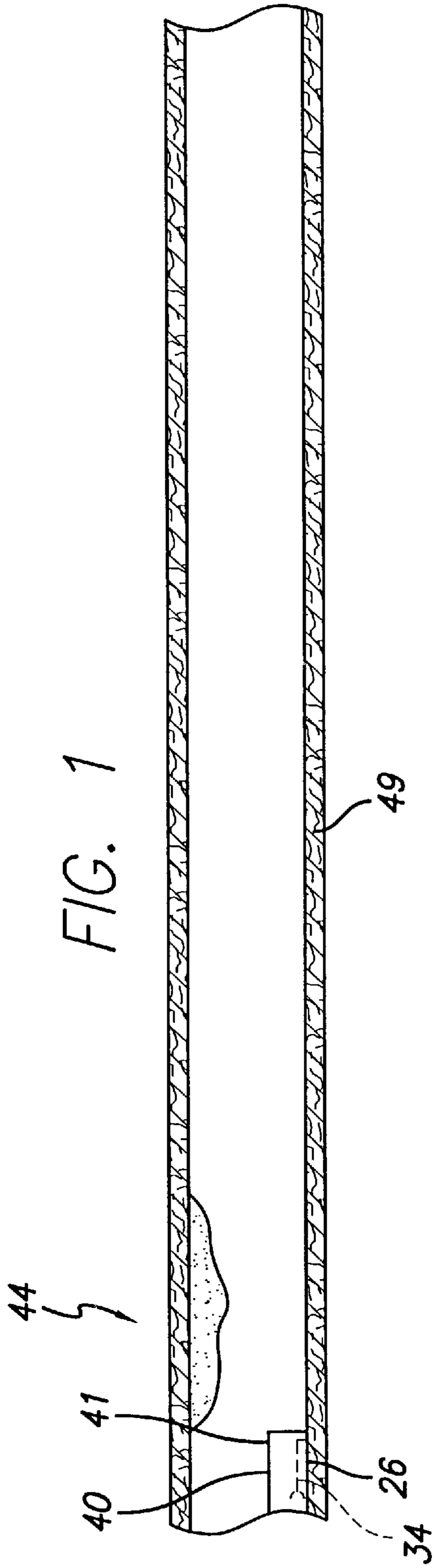
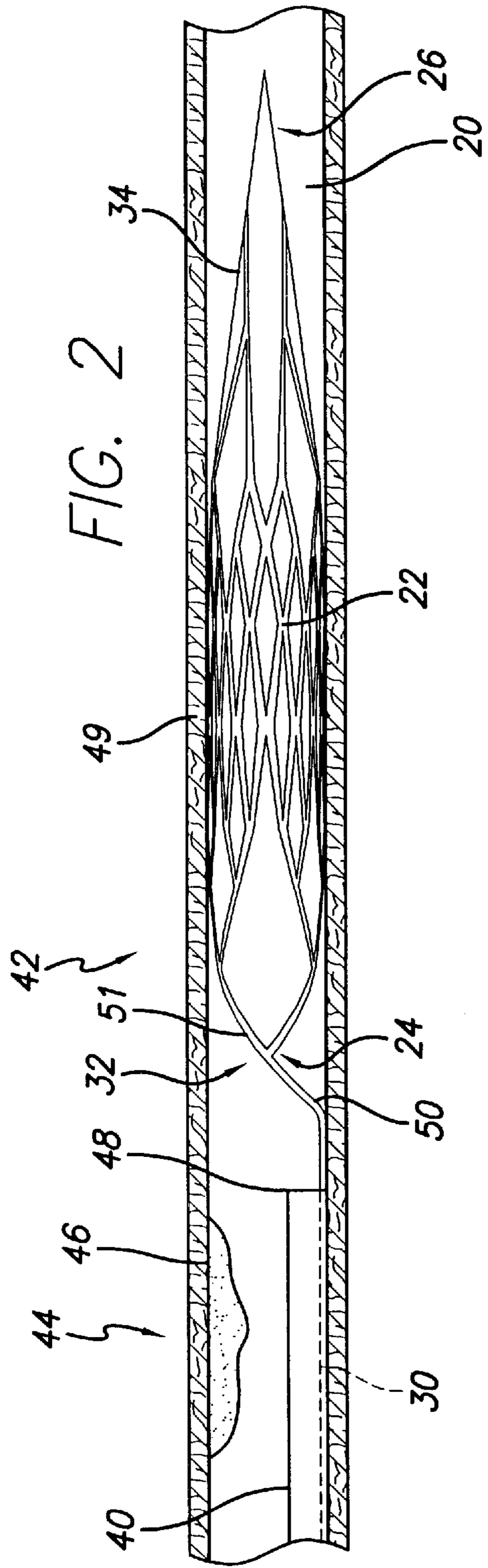

FIG. 2



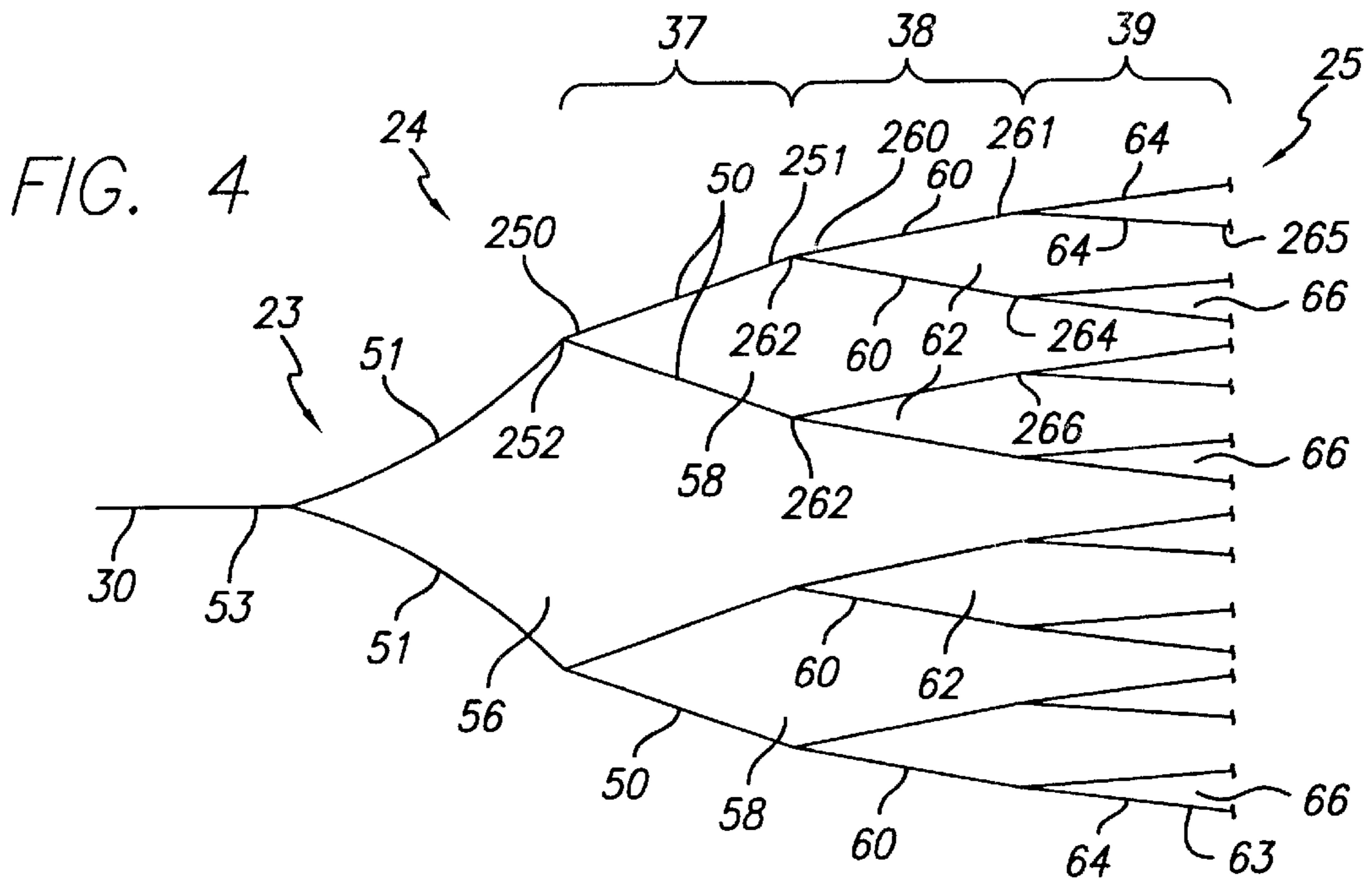
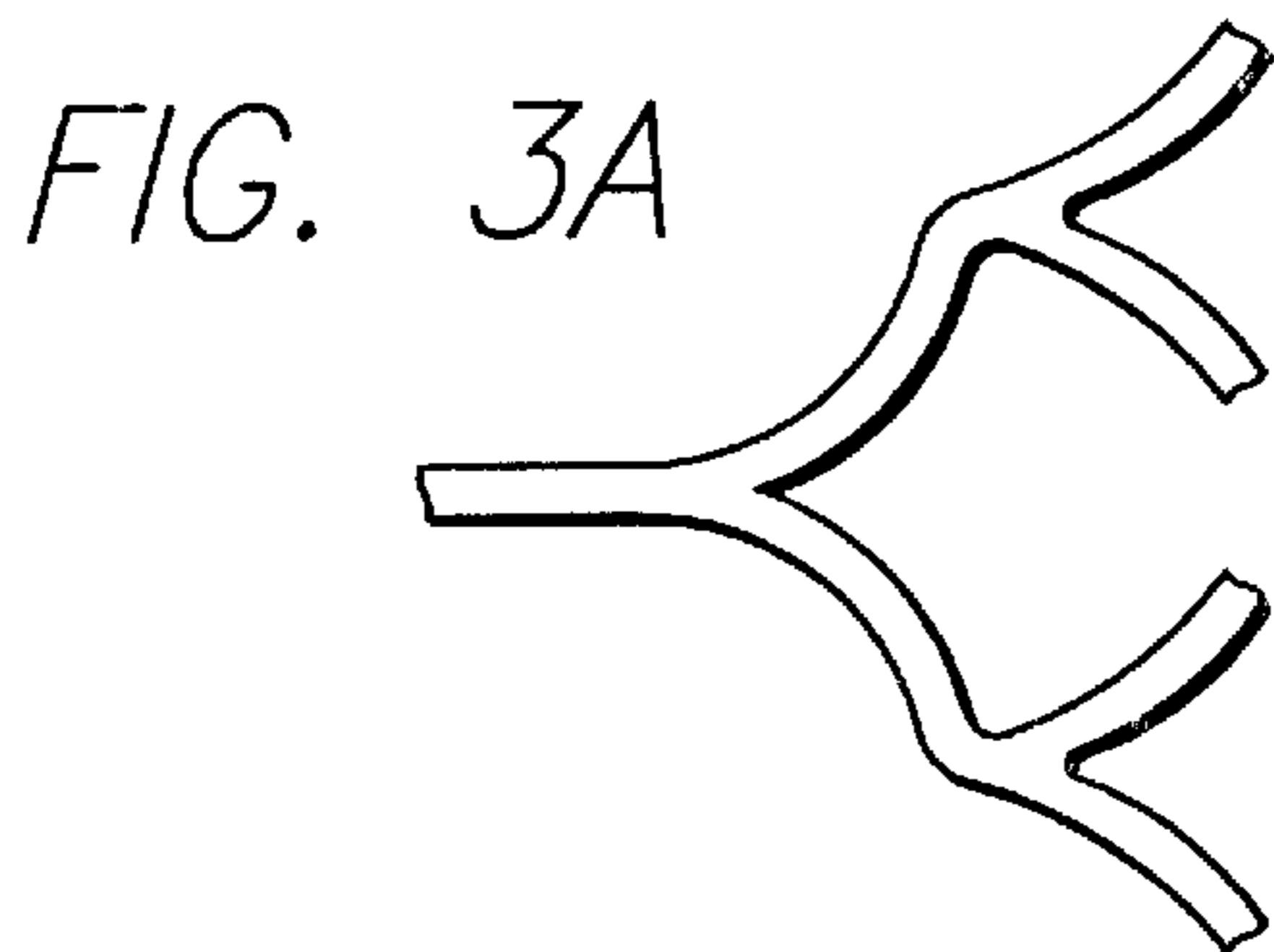
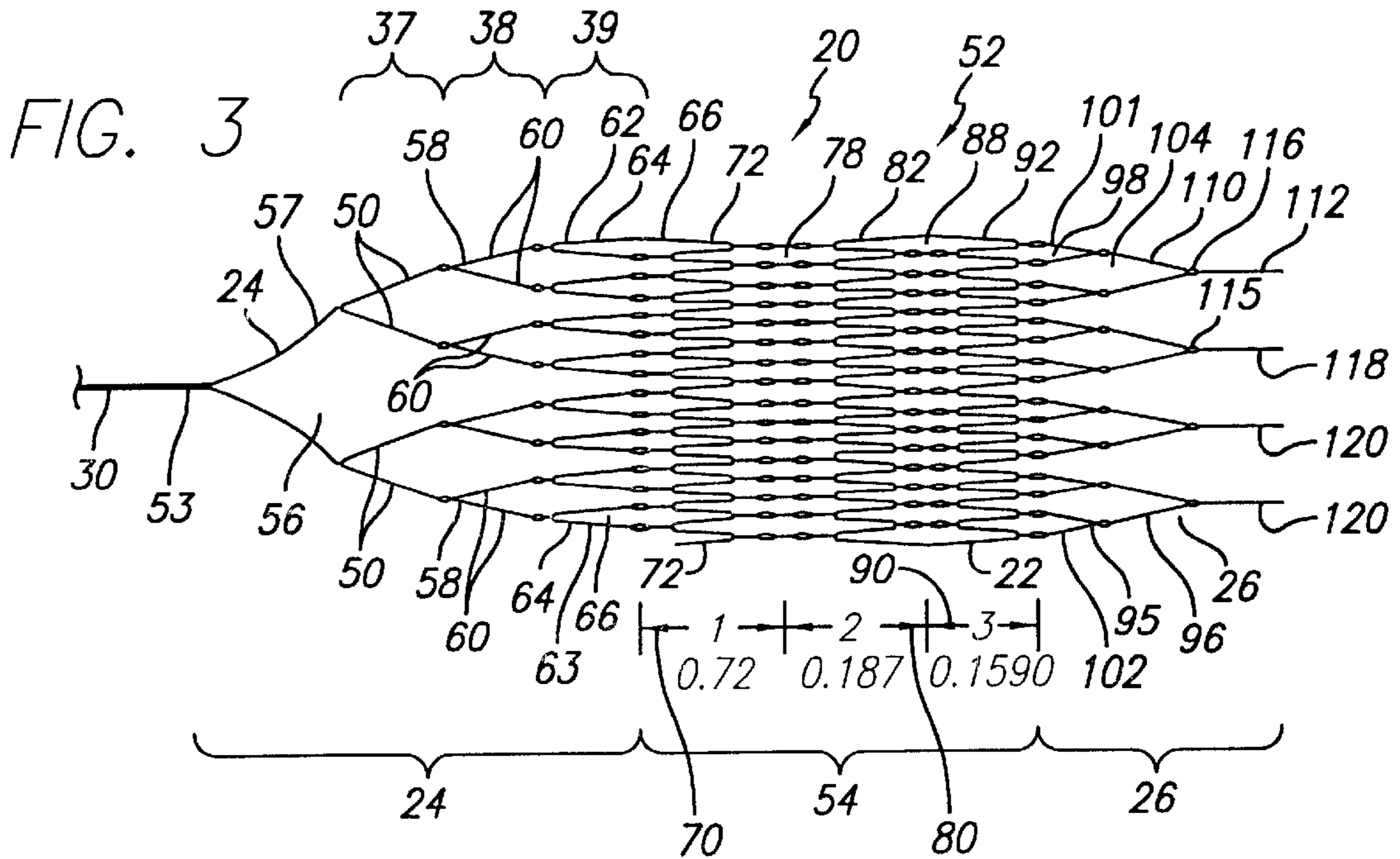

FIG. 5

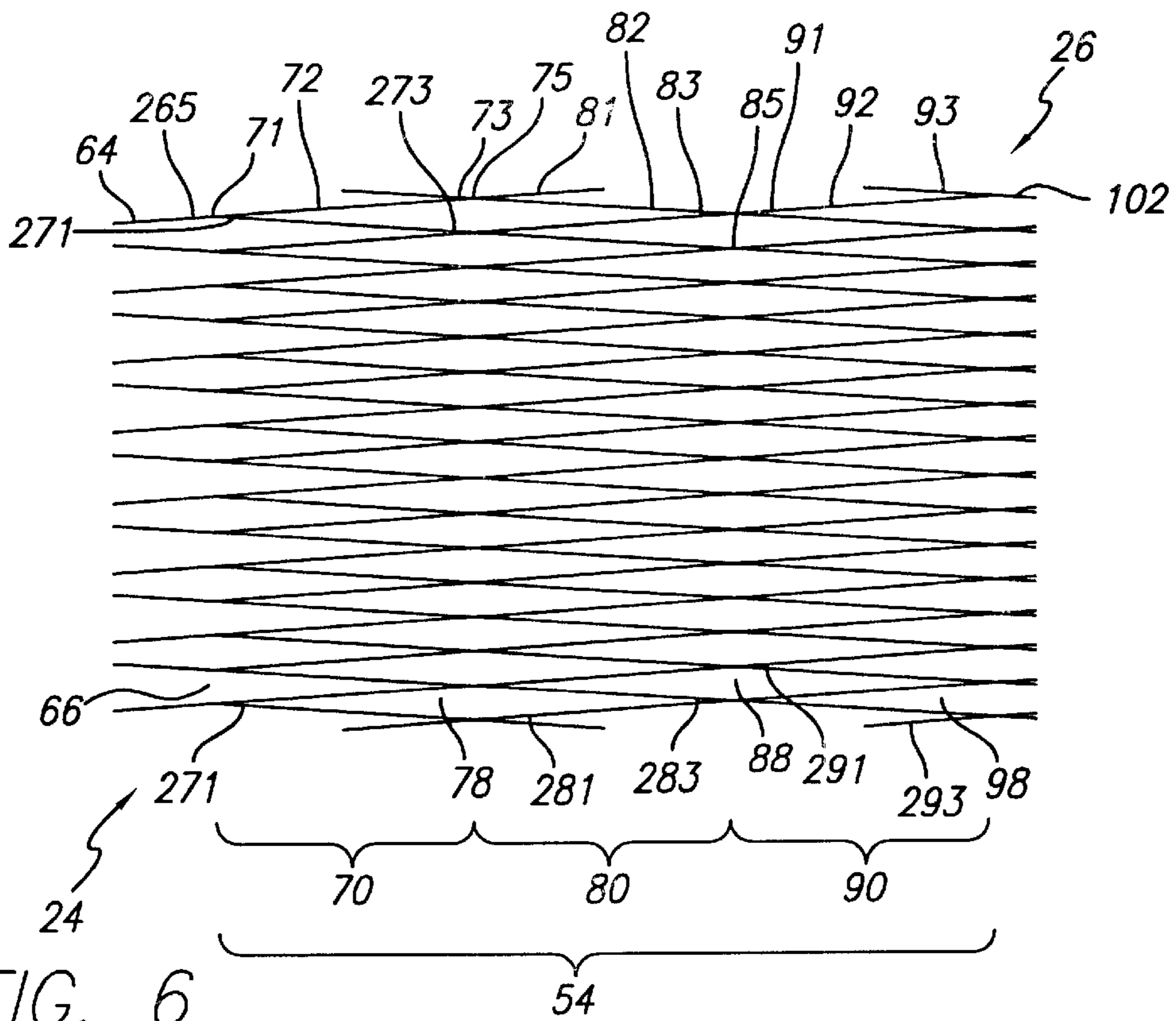
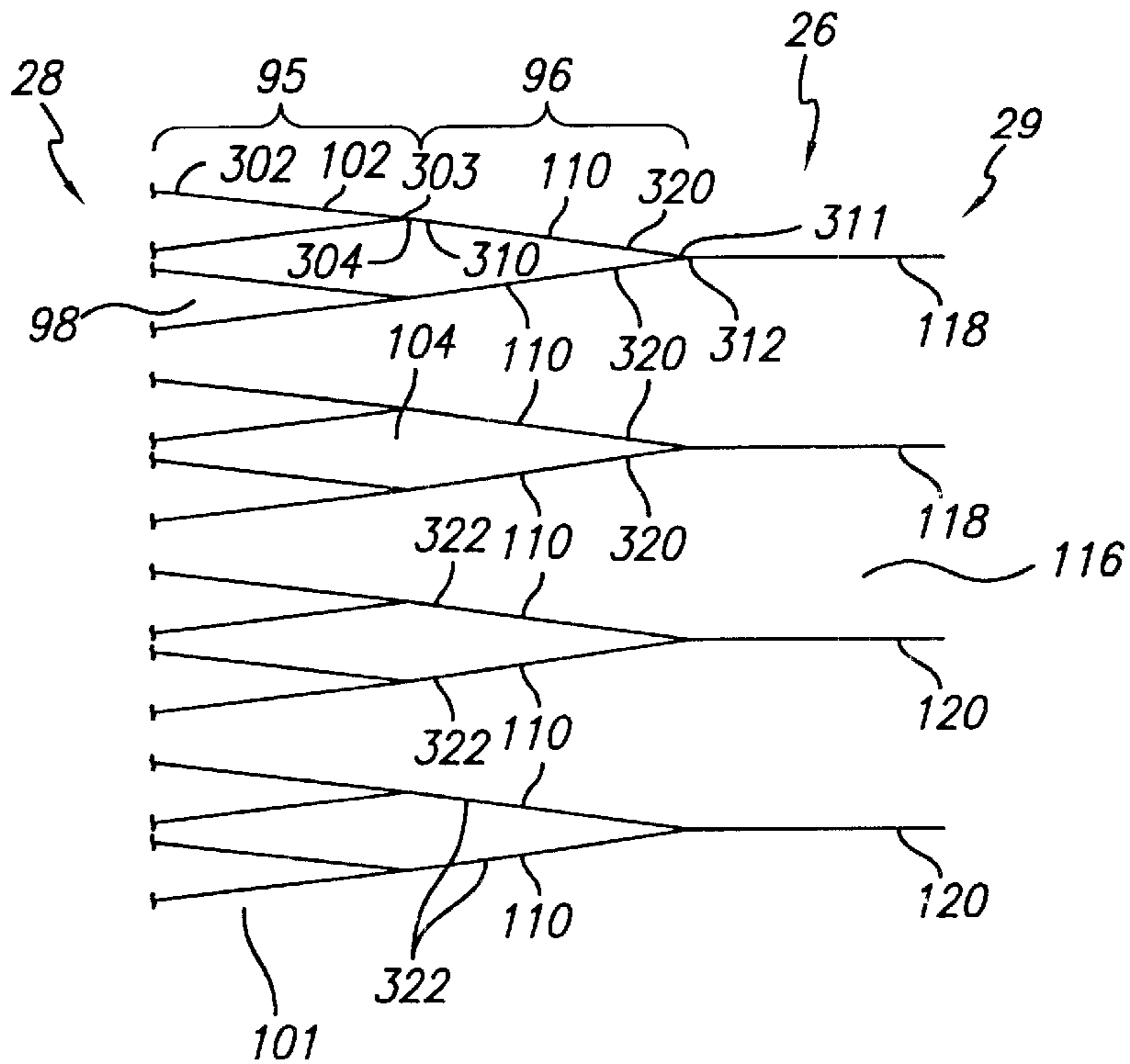

FIG. 6

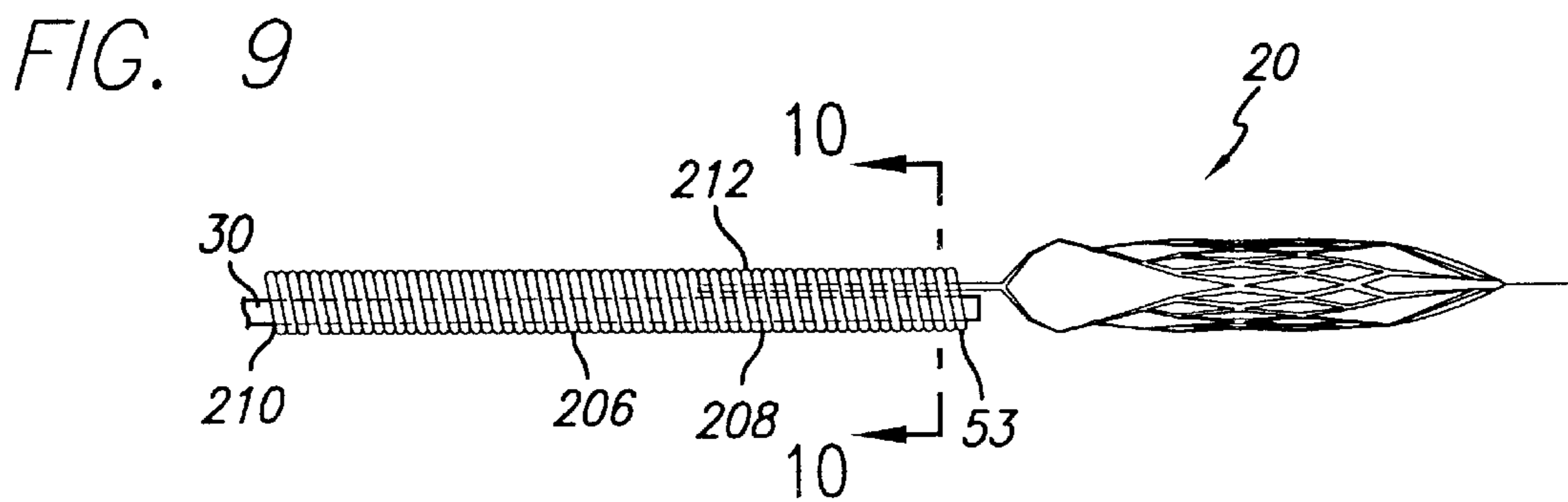
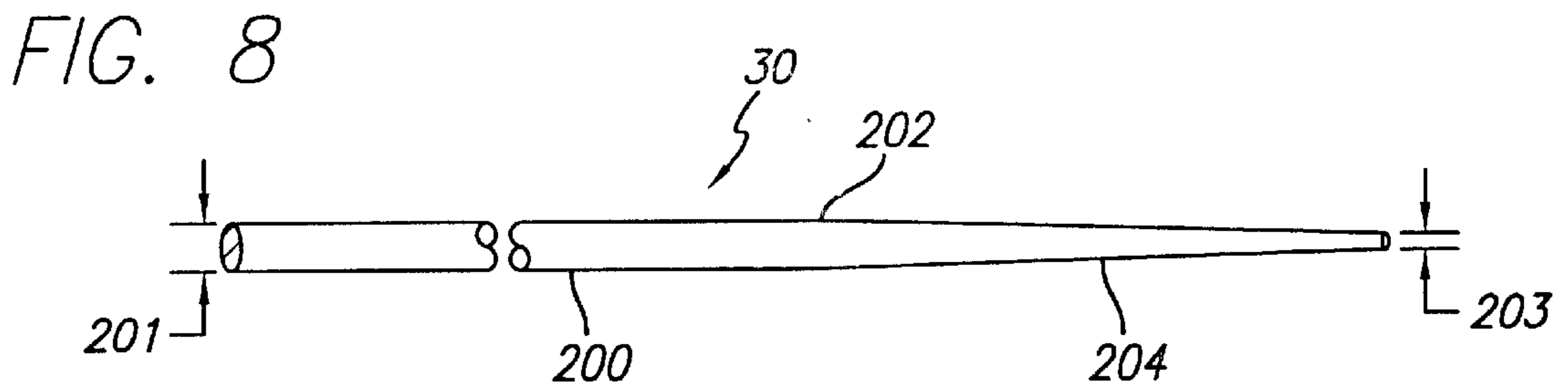
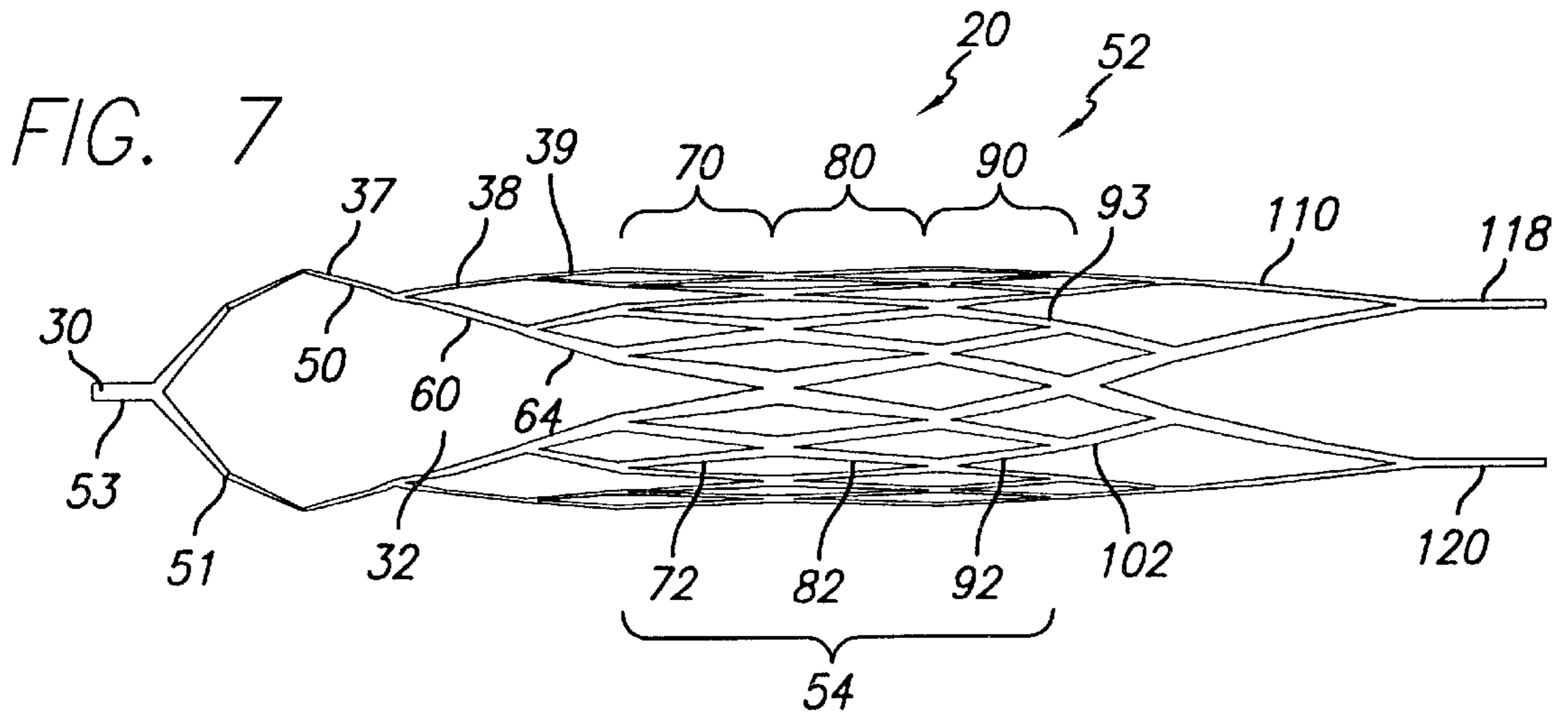

FIG. 10

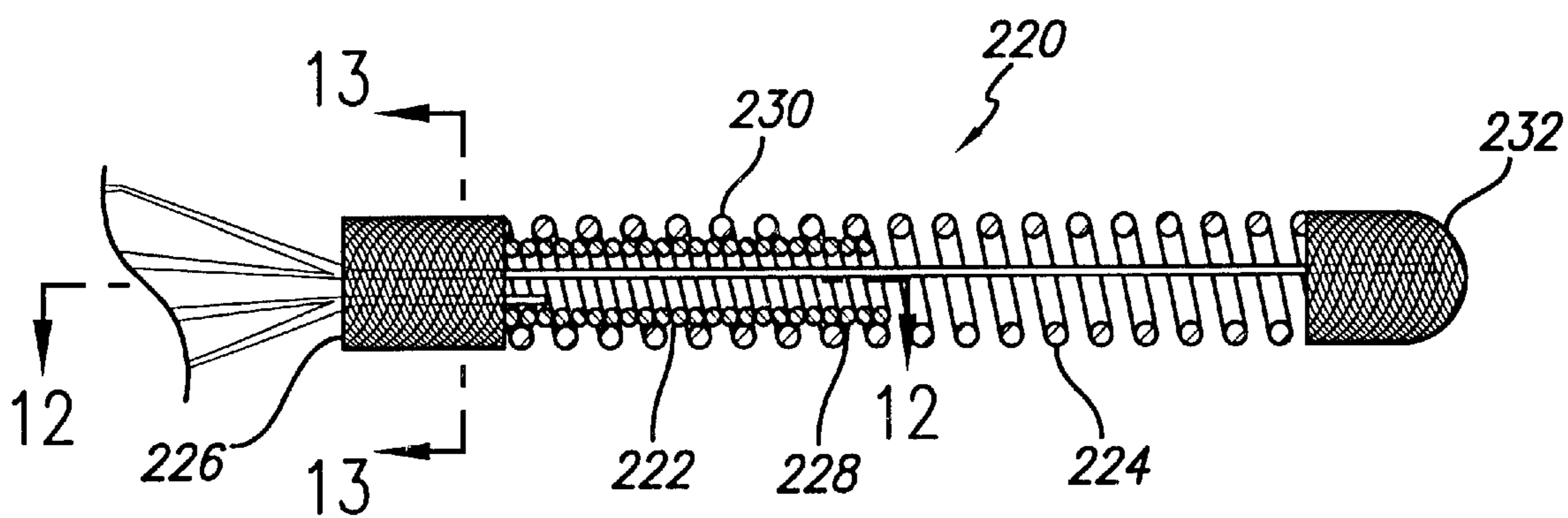
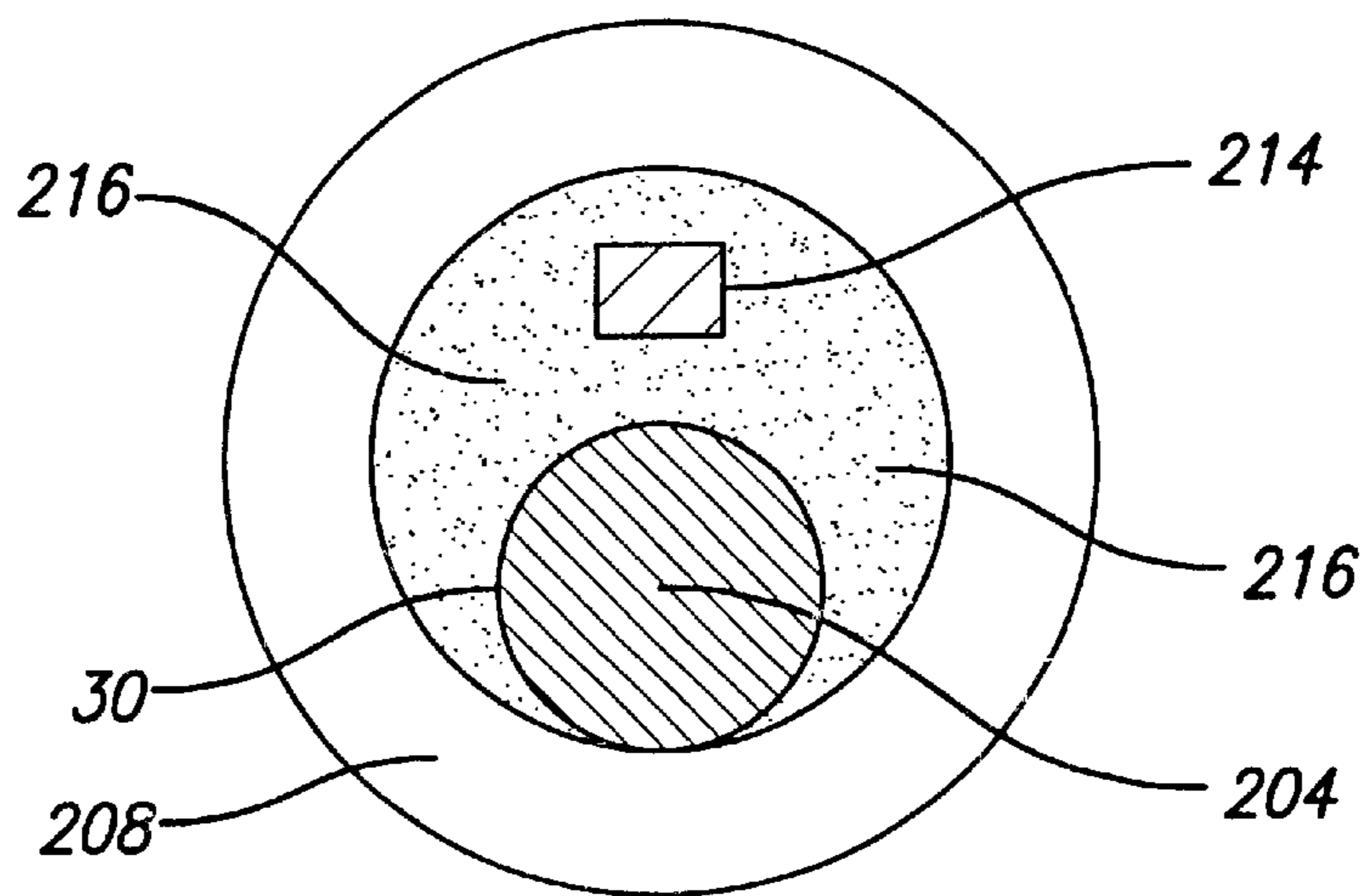

FIG. 11

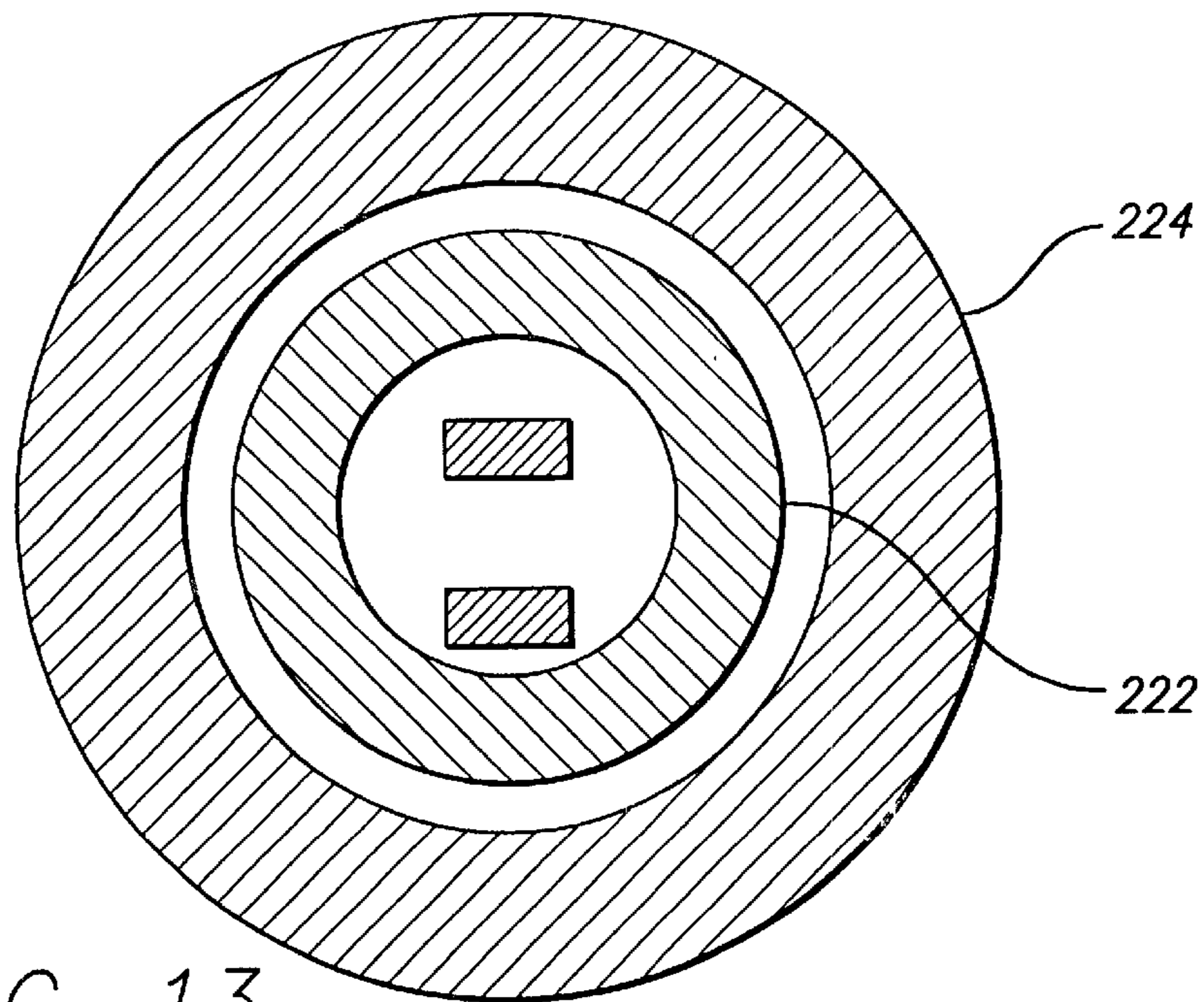
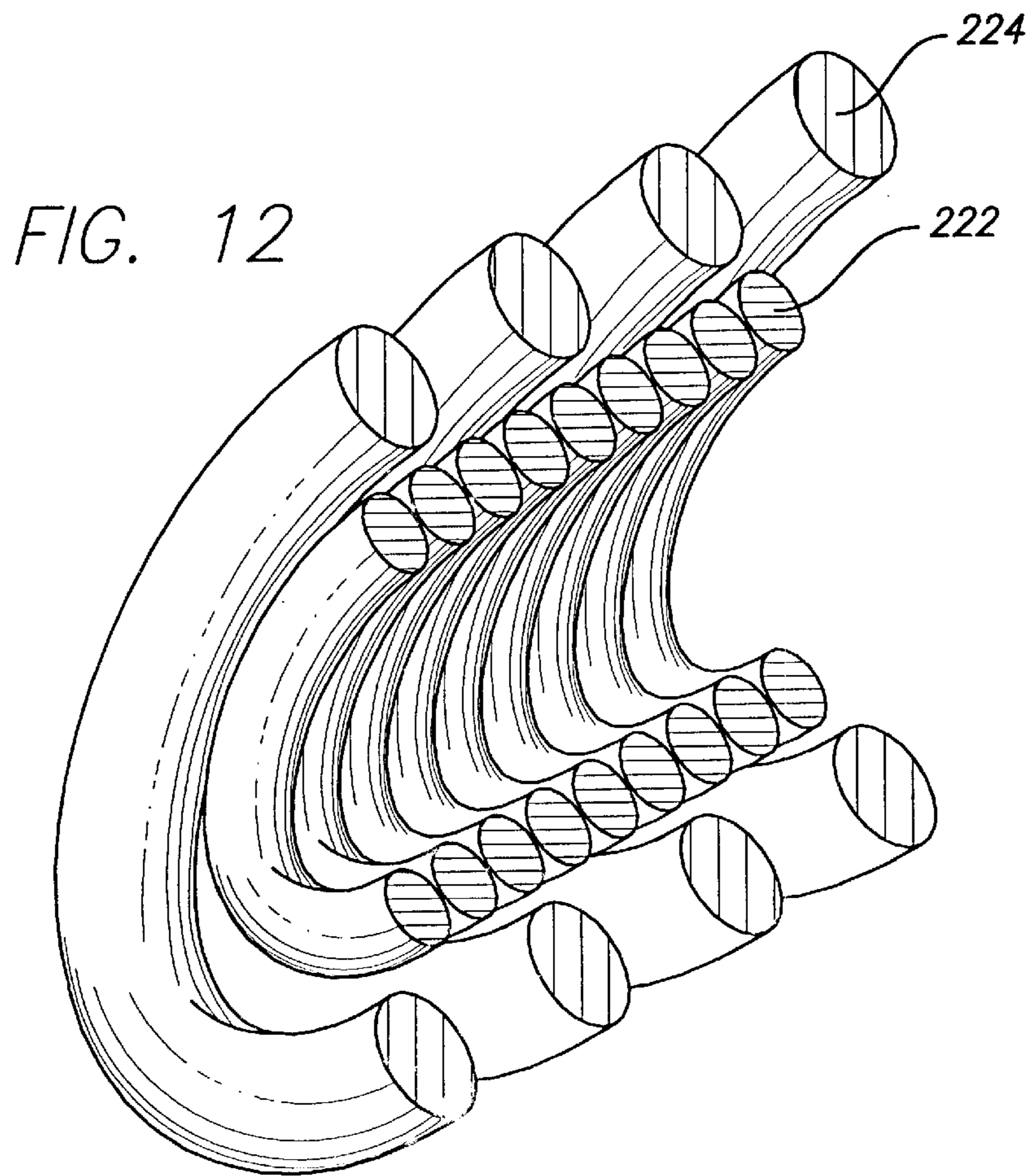

FIG. 13

FIG. 14

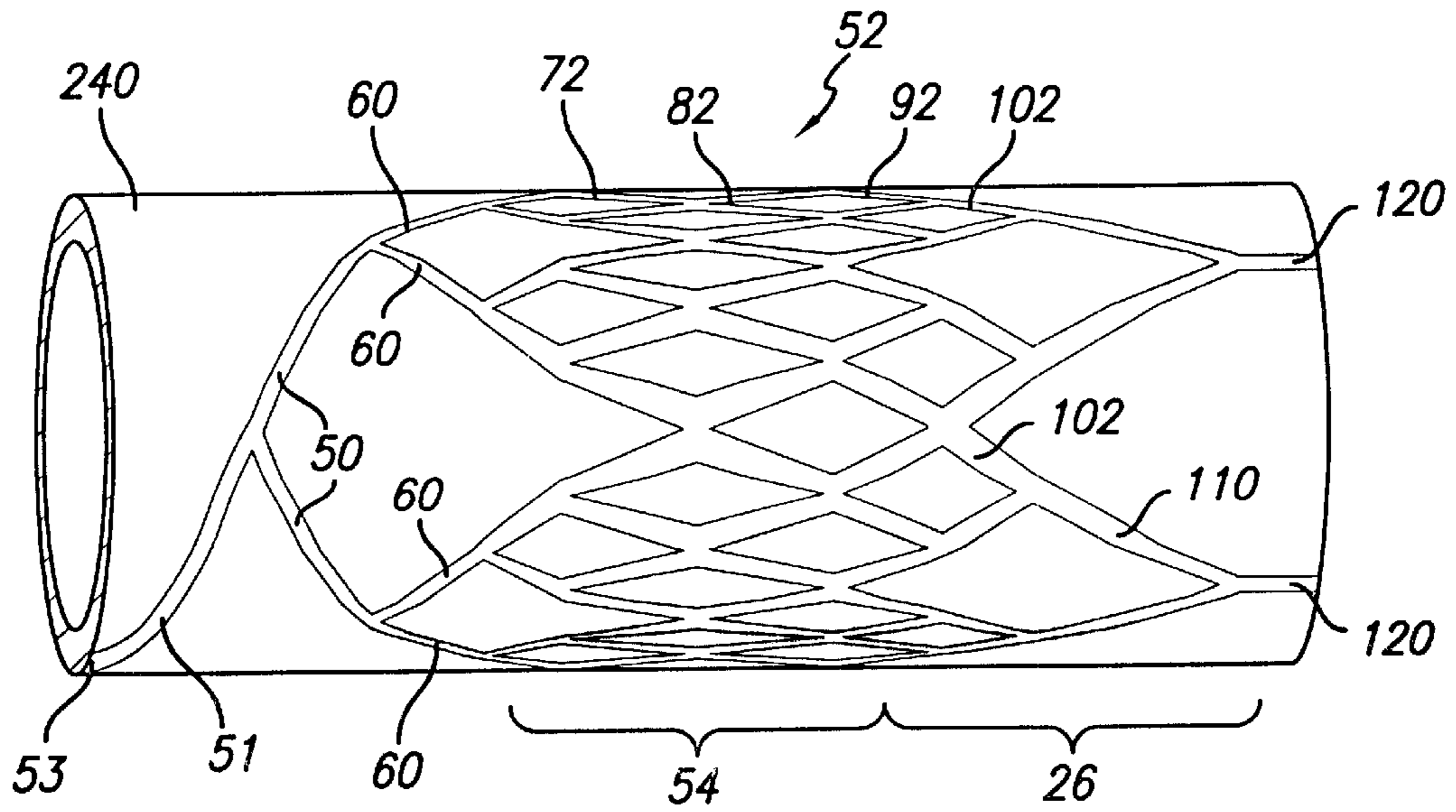
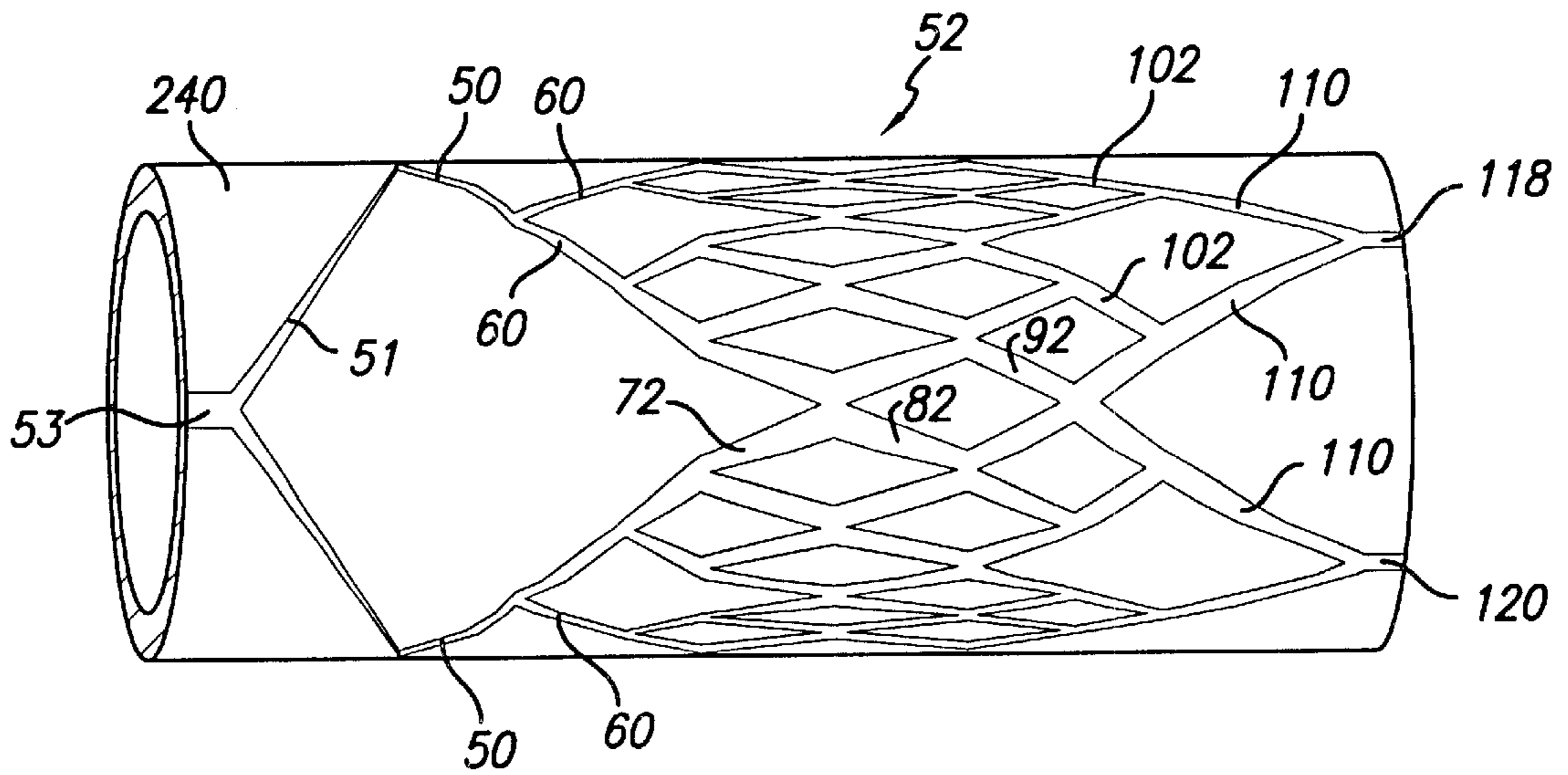

FIG. 15



EMBOLIC FILTER

BACKGROUND OF THE INVENTION

The present invention relates generally to intravascular devices and systems and more particularly, filter devices which can be used to capture embolic material or thrombi found in blood vessels.

The intravascular filter device and system of the present invention is particularly useful as a passive device utilized when performing balloon angioplasty, stenting procedures, laser angioplasty or atherectomy in critical vessels where the release of embolic debris into the bloodstream can occlude the flow of oxygenated blood to the brain or other vital organs, which can cause devastating consequences to the patient. While the filter device and system of the present invention is particularly useful in the cerebral vasculature and neuro-vasculature, the invention can be used in conjunction with any vascular interventional procedure in which there is an embolic risk.

A variety of non-surgical interventional procedures have been developed over the years for opening stenosed or occluded blood vessels in a patient caused by the build up of plaque or other substances on the wall of the blood vessel. Such procedures usually involve the remote introduction of the interventional device into the lumen of the artery, usually through a catheter. In typical carotid PTA procedures, a guiding catheter or sheath is percutaneously introduced into the cardiovascular system of a patient through the femoral artery and advanced, for example, through the vasculature until the distal end of the guiding catheter is in the common carotid artery. A guidewire and a dilatation catheter having a balloon on the distal end are introduced through the guiding catheter with the guidewire sliding within the dilatation catheter. The guidewire is first advanced out of the guiding catheter into the patient's carotid vasculature and is directed across the arterial lesion. The dilatation catheter is subsequently advanced over the previously advanced guidewire until the dilatation balloon is properly positioned across the arterial lesion. Once in position across the lesion, the expandable balloon is inflated to a predetermined size with a radiopaque liquid at relatively high pressures to radially compress the atherosclerotic plaque of the lesion against the inside of the artery wall and thereby dilate the lumen of the artery. The balloon is then deflated to a small profile so that the dilatation catheter can be withdrawn from the patient's vasculature and the blood flow resumed through the dilated artery. As should be appreciated by those skilled in the art, while the above-described procedure is typical, it is not the only method used in angioplasty.

Another procedure is laser angioplasty which utilizes a laser to ablate the stenosis by super heating and vaporizing the deposited plaque. Atherectomy is yet another method of treating a stenosed blood vessel in which cutting blades are rotated to shave the deposited plaque from the arterial wall. A vacuum catheter is usually used to capture the shaved plaque or thrombus from the blood stream during this procedure.

In the procedures of the kind referenced above, abrupt reclosure may occur or restenosis of the artery may develop over time, which may require another angioplasty procedure, a surgical bypass operation, or some other method of repairing or strengthening the area. To reduce the likelihood of the occurrence of abrupt reclosure and to strengthen the area, a physician can implant an intravascular prosthesis for maintaining vascular patency, commonly

known as a stent, inside the artery across the lesion. The stent is crimped tightly onto the balloon portion of the catheter and transported in its delivery diameter through the patient's vasculature. At the deployment site, the stent is expanded to a larger diameter, often by inflating the balloon portion of the catheter.

Prior art stents typically fall into two general categories of construction. A first type of stent is expandable upon application of a controlled force, as described above, through the inflation of the balloon portion of a dilatation catheter which, upon inflation of the balloon or other expansion means, expands the compressed stent to a larger diameter to be left in place within the artery at the target site. A second type of stent is a self-expanding stent formed from, for example, shape memory metals or super-elastic nickel-titanium (NiTi) alloys, which will automatically expand from a compressed state when the stent is advanced out of the distal end of the delivery catheter into the body lumen. Such stents manufactured from expandable heat sensitive materials allow for phase transformations of the material to occur, resulting in the expansion and contraction of the stent.

The above minimally invasive interventional procedures, when successful, avoid the necessity of major surgical operations. However, there is one common problem which can become associated with all of these types of procedures, namely, the potential release of embolic debris into the bloodstream that can occlude distal vasculature and cause significant health problems to the patient. For example, during deployment of a stent, it is possible that the metal struts of the stent can cut into the stenosis and shear off pieces of plaque which become embolic debris that can travel downstream and lodge somewhere in the patient's vascular system. Pieces of plaque material can sometimes dislodge from the stenosis during a balloon angioplasty procedure and become released into the bloodstream. Additionally, while complete vaporization of plaque is the intended goal during a laser angioplasty procedure, quite often particles are not fully vaporized and thus enter the bloodstream. Likewise, not all of the emboli created during an atherectomy procedure may be drawn into the vacuum catheter and, as a result, enter the bloodstream as well.

When any of the above-described procedures are performed in the carotid arteries, cerebral vasculature, or neuro-vasculature, the release of emboli into the circulatory system can be extremely dangerous and sometimes fatal to the patient. Naturally occurring debris can also be highly dangerous to a patient. That is, debris which travels through the blood vessel as a natural result of bodily functions and not as a result of an intervention procedure. Debris that is carried by the bloodstream to distal vessels of the brain can cause these cerebral vessels to occlude, resulting in a stroke, and in some cases, death. Therefore, although cerebral percutaneous transluminal angioplasty has been performed in the past, the number of procedures performed has been limited due to the justifiable fear of causing an embolic stroke should embolic debris enter the bloodstream and block vital downstream blood passages.

Medical devices have been developed to attempt to deal with the problem created when debris or fragments that naturally occur or that enter the circulatory system during or immediately following vessel treatment utilizing any one of the above-identified procedures. One approach which has been attempted is the cutting of any debris into minute sizes which pose little chance of becoming occluded in major vessels within the patient's vasculature. However, it is often difficult to control the size of the fragments which are formed, and the potential risk of vessel occlusion still exists, making such a procedure in the carotid arteries a high-risk proposition.

In addition, the retrieval of fragmented clot may be incomplete, also resulting in emboli and distal occlusions, and further, access through tortuous lumens may prove difficult. Laser-based disruption devices employ the photo-acoustic effect to fragment clot. Local disruption may open up a proximal occlusion but also may cause significant distal emboli.

Other techniques which have been developed to address the problem of removing embolic debris include the use of catheters with a vacuum source which provides temporary suction to remove embolic debris from the bloodstream. However, as mentioned above, there have been complications with such systems since the vacuum catheter may not always remove all of the embolic material from the bloodstream, and a powerful suction could otherwise cause problems to the patient's vasculature. Other techniques which have had some limited success include the placement of a prior art filter or trap downstream from the treatment site to capture embolic debris before it reaches the smaller blood vessels downstream. However, there have been problems associated with conventional prior art filtering systems as well. In particular, certain previously developed filtering devices do not optimize the area for embolic collection. That is, conventional filtering devices may not present a collection device that spans the entirety of the vessel or it may include supporting structure that itself impedes emboli collection. Certain other devices do not embody sufficient angular resistance to collapse.

Moreover, thrombectomy and foreign matter removal devices have been disclosed in the art. However, in addition to suffering from the same disadvantages as certain conventional prior art filter devices, such devices have been found to have structures which are either highly complex such as with multiple components or highly convoluted geometry or lacking in sufficient or effective expansion and retraction capabilities. Disadvantages associated with the devices having highly complex structure such as multiple components or highly convoluted geometry include difficulty in manufacturability as well as use in conjunction with microcatheters. Other devices with less coverage can pull through clots due in part to the lack of experience in using the same or otherwise lack an expanded profile that is adequate to capture clots or foreign bodies.

What has been needed is a reliable intravascular filter device and system for use when treating blood vessels. The filter device should be capable of capturing any naturally occurring embolic debris or that which may be released into the bloodstream during an interventional treatment, while minimizing the profile during delivery and maximizing coverage when deployed. The devices should embody an expanded profile that presents a consistent radial opening that completely occupies the vessel at the repair site as well as structure for effectively resisting collapse. Moreover, such devices should be relatively easy to deploy and remove from the patient's vasculature and also should be capable of being used in narrow and very distal vasculature such as the cerebral vasculature. The following invention addresses these needs.

SUMMARY OF THE INVENTION

Briefly and in general terms, the present invention is directed towards filter devices for capturing and removing undesirable material or objects which may occur during treatment, and thereby maintaining and restoring the patency of the blood vessel. The filter devices of the present invention are a linked or monolithic framework of thin struts that

are radially expansible, and embodies a structure that provides a consistent radial opening as well as improved radial and angular resistance to collapse. That is, as the device is pulled such as through a vessel, the entrance thereto will not fall back or tip over. Moreover, the filter device maintains clearance in its interior space along its length allowing the undesirable materials or objects to enter and be captured.

In one aspect of the invention, the filter includes struts (members running both generally longitudinally and generally circumferentially) with very small widths and thicknesses and rings (circumferential members) with very small widths and thicknesses but large expansion ratios. Manufacturing, such as laser cutting or etching, the device from a piece of tubular stock facilitates creating the very small widths and thicknesses in the filter body. The body of the filter device is defined by a plurality of openings bounded by generally longitudinally and generally circumferentially extending members. A proximally extending member is attached to an elongate wire and the assembly is contemplated to be used in conjunction with a generally tubular delivery catheter. The filter device can be made from a tubular element or can be formed from a sheet which is rolled into a tubular shape.

The present invention provides a structure that has the capacity to capture and retain naturally occurring or foreign bodies while having a minimal profile that can traverse easily and repeatedly through a standard microcatheter across tortuous anatomy. The device embodies superior flexibility allowing it to be deployed and retrieved consistently across difficult anatomy while being able to retain captured material. The inner diameter of the device is heat-set to a pre-determined size. It is envisioned that there be a family of devices that have varying strut lengths, thicknesses, flexibility, and diameters as deemed appropriate for the specific type of vascular or non-vascular setting for which the device is to be used.

In a presently preferred embodiment, the filter device is self-expanding and includes a mid-section that forms a generally tubular profile. The proximally extending member projects as an axial extension of a line at the surface of the cylinder generally defining the substantially tubular portion to thereby provide an unobstructed opening at the proximal end of the filter. A terminal (i.e., distal) end of the filter device is constricted or closed so as to form a pocket for receiving emboli or thrombotic debris.

The filter device of the present invention can assume a number of different forms. In one presently preferred embodiment, the filter device embodies a first end portion, a second end portion, and a mid-portion having a plurality of consecutive rings, each ring having a plurality of generally straight members configured in an alternating V-pattern providing a plurality of proximal and distal apices on each ring. The generally straight members of the mid-portion rings that are configured in an alternating V-pattern may include a sixteen (16) apex design and therefore may require thirty-two (32) straight members. In another aspects, the filter device mid-section may include rings having different lengths or, in the alternative, include a proximal section having different lengths. In the embodiments, the plurality of members can be curved, S-shaped, etc. rather than straight or can be a combination of straight and curved, etc.

Moreover, the present invention embodies a tip for an endovascular device including an atraumatic soft coil for preventing damage to tissue and facilitates advanceability. The tip further includes multiple layers of coiled material to enhance these objectives as well as to provide stiffness variations.

These and other objects and advantages of the invention will become apparent from the following more detailed description, when taken in conjunction with the accompanying drawings of illustrative embodiments.

BRIEF DESCRIPTION OF THE DRAWINGS

FIG. 1 is a side view, partially in cross-section, of a vessel partially occluded by a stenosis and a distal portion of a delivery catheter and intravascular filter device of the present invention positioned proximate the debris;

FIG. 2 is a side view, partially in cross-section, of the intravascular filter as deployed within the vessel of FIG. 1;

FIG. 3 is a plan view, depicting a pattern of a preferred embodiment of an intravascular filter of the present invention as if the filter was cut longitudinally and unrolled to show its pattern in a flat configuration;

FIG. 3a is an enlarged view of a portion of the filter of the present invention, depicting an alternative embodiment of members defining the filter;

FIG. 4 is a plan view, depicting an enlarged proximal section of the intravascular filter of FIG. 3;

FIG. 5 is a plan view, depicting an enlarged distal section of the intravascular filter of FIG. 3;

FIG. 6 is a plan view, depicting an enlarged mid-section of the intravascular filter of FIG. 3;

FIG. 7 is a perspective view, depicting a laser-cut configuration of the intravascular filter of FIG. 3;

FIG. 8 is a plan view, depicting an elongate member of the present invention;

FIG. 9 is a side view, partially in cross-section, depicting a plurality of coils configured about a distal end portion of the elongate members in combination with a filter device of the present invention;

FIG. 10 is a cross-sectional view, depicting the assembly of FIG. 9 taken along lines 10—10;

FIG. 11 is a side view, partially in cross-section, depicting a distal end portion of a tip of the filter device of the present invention;

FIG. 12 is a cross-sectional view, depicting a portion of the assembly of FIG. 11 taken along lines 12—12;

FIG. 13 is a cross-sectional view, depicting the assembly of FIG. 11 taken along lines 13—13;

FIG. 14 is a perspective side view, depicting the filter device pattern projected onto the tubing from which it will be cut to produce the filter device of FIG. 3; and

FIG. 15 is a perspective bottom view, the filter device pattern projected onto the tubing from which it will be cut from to produce the filter device of FIG. 3.

DETAILED DESCRIPTION OF THE PREFERRED EMBODIMENTS

Referring now to the drawings, and in particular FIGS. 1 and 2, there is shown a filter device of the present invention. The filter device 20 is adapted to provide more consistent and improved radial opening as well as enhanced angular resistance to collapse. Moreover, the filter device 20 of the present invention is configured to facilitate the maintenance of clearance in its interior space along its length allowing undesired materials or objects found in the blood stream to enter and be captured.

Furthermore, since it is contemplated that the filter device 20 be manufactured from a tubular member to form elements with very small widths and thicknesses, the device is

thus more easily packed to a relatively smaller diameter and inherently embodies high longitudinal flexibility.

The filter device 20 (FIG. 2) of the present invention includes a body 22 having a proximal end portion 24 and a distal end portion 26. The proximal end portion 24 is intended to be affixed to a terminal end portion of an elongate member 30 (i.e., wire; described in more detail below). In a presently preferred embodiment, the body 22 of the filter device 20 is generally tubular with a proximally directed opening 32 and a generally closed terminal end 34 to thereby form a filter for receiving embolus, stones, thrombus and foreign bodies found in vasculature, which may be free flowing within the blood stream during or as a result of treatment.

The filter device 20 for intravascular uses is contemplated to be used in conjunction with a generally tubular delivery catheter 40, such as a microcatheter. Additionally, it is contemplated that a conventional guide catheter (not shown) be used in combination with the delivery catheter 40 loaded with a filter device 20. A guide catheter (not shown) is employed to provide a guide within a patient's vasculature through which the delivery catheter 40 is inserted. A proximal end of the guide may have attached a rotating hemostatic valve fitted with sealing hemostatic valves. The filter device 20 is intended to be self-expandable, however, it is possible to employ an expandable member such as a balloon catheter (not shown) to radially expand a filter device that is not self-expandable, but rather must be deformed to assume an expanded configuration.

In use, the body 22 of a filter device 20 is inserted proximally in a compressed configuration coaxially within an internal bore of the generally tubular delivery catheter 40. The longitudinally extending elongate member 30 which is attached to the proximal end 24 of the body 22, is likewise coaxially received within the delivery catheter 40. Both the body 22 and elongate member 30 are slidable within the delivery catheter 40 and accordingly, the delivery catheter 40 and the filter device 20 can be displaced longitudinally with respect to each other.

A typical procedure will now be described. In order to ensure patency in a vessel during treatment, the filter device/delivery catheter assembly 42 is introduced into a patient's vasculature using conventional means such as the Seldinger technique. Sometimes, a cutdown is made to gain access to the patient's vasculature. Using standard endovascular techniques, the treatment area 44 in the vasculature is located. The treatment area 44 is crossed with the delivery catheter 40 and an appropriate guidewire (not shown). If angiographic mapping was not possible prior to crossing the treatment area, contrast is injected distal to the occlusion to map the distal vessels. The tip 41 of the delivery catheter 40 is positioned one device length or slightly more downstream of the treatment area 44 where blood will naturally flow across the device. The guidewire is removed and the filter device 20 is loaded through a rear hub (not shown) of the delivery catheter 20 with the assistance of an introducer sheath (not shown). The filter device 20 is advanced 30–40 cm and the introducer sheath is then removed.

Next, the filter device 20 is deployed into the diseased vessel by advancing the filter device until the distal tip 26 of the filter is positioned at the distal end of the delivery catheter 40. The filter device 20 is held in place by the operator holding the elongate member 30 still while the catheter 40 is retracted to allow the filter device to expand. Holding the filter device 20 in place, the catheter 40 is pulled back and removed from the patient allowing the filter 20 to

be deployed at a position slightly downstream of the treatment site **44** to capture any free flowing emboli which may occur during subsequent treatment. Once complete, i.e., performance of the treatment is complete and any free flowing emboli is contained within the filter device **20**, the filter is resheathed or partially resheathed into the guide catheter or a recovery catheter and retracted out of the patient's vasculature.

In one embodiment, during retraction of the system **42**, the system is drawn back until the distal end of a proximal device marker coil (described below) is at the tip of the guide. At this point, a large syringe, perhaps 60 cc, is attached to the guide catheter at the rotating hemostatic valve on the hub. The guide catheter is aspirated as the filter device **20** and any captured emboli are drawn into the guide. Aspiration is maintained until the filter device **20** is fully into the rotating hemostatic valve of the guide catheter, but the filter device **20** is not yet drawn through the hemostatic valve. The rotating hemostatic valve is detached and removed with the filter device in it, allowing a moment of bleed back through the guide to flush any loose emboli. Optionally, then a second rotating hemostatic valve is attached to prevent excessive bleed back. The guide is then flushed with saline.

The manner in which the body portion **22** of the filter device **20** self-expands within the vasculature and the resultant expansion profile provides a number of advantages. In particular, the body **22** expands to conform to the diseased vessel at a position slightly adjacent to the repair site **44**. That is, the generally tubular profile of the body portion **22** substantially conforms to the walls defining the blood vessel **49**, therefore, any free flowing emboli dislodged into the blood during an intravascular operation may be completely captured within the deployed filter **20**. Moreover, the expansion of the body **22** facilitates the maintenance of clearance in its interior space along its length allowing the material or objects **46** to freely enter and be captured and specifically provides a substantially unobstructed access to the proximally directed opening **32** to the body **22**. Significantly, as the body **22** self-expands, members **50** and **51** leading to the opening **32** to the body **22** are angled or oriented so as to be adjacent the walls defining the blood vessel **49** and are therefore substantially removed from the flow path to thereby provide an unobstructed opening **32**.

In its expanded state, the filter device **20** is particularly well-suited to capture and remove free flowing embolic or thrombotic debris from the diseased blood vessel **49**. Once the intravascular treatment has been completed and any debris resulting therefrom has been captured within the filter device **20**, the system **42** can be removed from the patient's vasculature or the filter device **20** containing the debris **46** can first be pulled within the guide catheter (not shown) and then the assembly **42** removed from the target repair site **44**. Also, just the proximal end portion **24** of the filter device **20** can be cinched down to lock the debris without being fully pulled into the delivery catheter **40**.

It is to be understood, however, that thrombus or other blood-based material captured within the filter may be eliminated in a variety of ways. For example, the material may be drawn into the guide catheter with the aide of a suction applied to the guide catheter, and removed from the body. Also, these materials may be removed from the diseased vessel **49** and allowed to dissolve under natural or induced lytic processes. Alternately, the material may be inserted into other vasculature more tolerant of occlusion and released.

Referring now to FIGS. 3-7, there is shown a preferred pattern **52** of the filter device **20** of the present invention. As

will be developed further below, it is contemplated that the filter pattern **52** be cut from a tubular member using a laser. Alternatively, the pattern can be made from a flat sheet of nitinol and rolled into a tubular basket body. As best seen shown as if it was cut longitudinally and unrolled to show its pattern in a flat configuration (FIG. 3), the filter pattern **52** includes a body **22** having a proximal section **24**, a distal section **26**, a mid-section **54** and an elongate member **30** extending proximally from the proximal end section **24**.

Referring in particular to FIG. 4, the proximal end section **24** has a proximal end **23** and a distal end **25** and includes a plurality of member sections **37**, **38** and **39**. Each member section includes a plurality of members or leashes **50**, **60**, and **64**, respectively, which lead to and aid in defining an opening **32** (FIGS. 2 and 7) to the body **22**, when in its tubular configuration. The members **50**, **60**, and **64** of each "member section" **37**, **38**, and **39** respectively, are pair-wise configured in a V-shape such that the proximal end of a member pair form the vertex of the V-shaped pair while the distal ends of each member pair form open ended end points for further distal connections. Therefore, the first member section **37** includes four generally straight members **50**, each member having a proximal end **250** and a distal end **251**. The generally straight members **50** are pair-wise in a V-shape with the proximal ends **250** forming a vertex **252** of the V-shape and the distal ends **251** forming the open ended branch end points of the V-shape. It is to be recognized that the members defining the body **22** of this or any other embodiment can have various shapes (See FIG. 3a). For example, the members can be curved, S-shaped, arced, or include straight portions or any combination of the same.

The second member section **38** is similarly configured as the first member section **37** having a plurality of generally straight members **60** also pair-wise configured in a V-shape. Each of eight (8) members **60** includes a proximal end **260** and a distal end **261**. The proximal end **260** of the generally straight members **60** form vertices **262** and each vertex **262** is merged with one of the four distal ends **251** of the generally straight members **50** of the first member section **37**.

Additionally, a third member section **39** is also provided having a plurality of generally straight members **64**. Each of the sixteen (16) generally straight members **64** having a proximal end **264** and a distal end **265** are configured in the same fashion as the generally straight members **50** and **60** of the first member section **37** and second member section **38** in a pair-wise V-shape configuration. A plurality of proximal vertices **266** formed by the proximal ends **264** of the generally straight members **64** are merged with each of the eight distal end points **261** of the generally straight members **60** of the second member section **38**. In this configuration, the distal section of the third member section **39** includes sixteen open-ended end points **265** between the body proximal section **26** and the body mid-section **54** (as shown in FIG. 3).

It is noted that the first, second, and third member sections **37**, **38**, and **39** of the proximal section **24** are configured to "fan-out" distally such that at each distal end of each member section, there is a doubling of the number of open-ended branch end points available for connection to successive member sections of the proximal section **24**. Therefore, at the distal end of the first member section **37**, there are four open-ended branch end points **251**, at the distal end of the second member section **38**, there are eight open-ended branch end points **261**, and finally, at the distal end of the third member section **39**, there are sixteen open-ended branch end points **265**. In this "fan-out"

configuration, any desired number of end points at the distal end **25** of the proximal section **24** may be achieved by simply including more or less successive member sections. A sixteen (16) open-ended branch end point configuration was illustrated (as shown in FIG. 4) and described as having three member sections, however, for example, a proximal section having eight (8) open-ended branch end points, only two member sections are required and alternatively for a proximal section having thirty-two (32) open-ended branch end points, a fourth member section will be required (not shown).

The proximal end portion **24** further embodies a pair of connectors **51** extending proximally at an angle or in a curved fashion from the straight members **50** to thereby accomplish offsetting elongate member **30** from a central axis of the tubular body **22** of filter device **20** as best seen in FIGS. 2 and 7. The connectors **51**, in turn, converge to form a proximally directed tab **53** that is connected to the elongate member **30**. The straight members **50**, **60**, **64** and connectors **51** define a centrally located, generally diamond-shaped aperture **56**, having a first length, that is substantially sandwiched between a plurality of diamond-like shaped proximal apertures **58**, **62**, and **66**. The apertures **58**, **62**, and **66** each being progressively smaller in size and having progressively shorter lengths than the length of aperture **56** allow the filter device to “funnel” embolic or thrombotic debris into the filter body **22** where it is captured and retained. In its tubular configuration, a proximal convoluted ring **63** defined by members **64** is located and makes up the distal end **25** of the proximal end portion **24**. The ring **63** provides for optimal radial opening to the filter body **22**.

Referring to FIG. 5, the device distal section **26** has a proximal end **28** and a distal end **29** and includes a plurality of member sections **95** and **96**. Member section **95** includes a plurality of straight members **102** having a proximal end **302** and a distal end **303**. Similarly member section **96** includes a plurality of straight members **110** having a proximal end **310** and a distal end **311**. The straight members **102** and **110** of each member section **95** and **96** are pair-wise configured in a V-shape such that the proximal ends **302** and **310** respectively of each member pair form open-ended end points for connection with the distal vertices of the member section located proximally adjacent to it. In member section **95**, distal ends **303** of a pair of straight members **102** converge to form a vertex **304** of the V-shaped pair. In the member section **96**, distal ends **311** of a pair of straight members **110** converge to form a vertex **312** of the V-shaped pair.

Therefore, the first member section **95** includes sixteen (16) straight members **102**. The straight members **102** are pair-wise in a V-shape with the proximal ends **302** comprising the open-ended branch ends of the V-shape and the distal ends **303** converging to form the eight vertices **304** of the V-shape. The second member section **96** is similarly configured as the first member section **95** having eight (8) straight members **110** also configured in a V-shape. The proximal ends **310** of the straight members **110** form the open-ended branch ends of the V-shape and merge into each of the eight vertices **304** of the first member section **95**. Pairs of the straight members **110** converge distally into four vertices **312**, which are part of the distally directed straight members **118** and **120**.

It is contemplated that the straight members **110** of the second member section **96** may be configured having different lengths. For example, of the eight (8) straight members **110** within the second member section **96**, four straight members **320** may have a first length that may be longer in

length than the other four straight members **322** having a second shorter length. In this configuration, two of the converging vertices **312** resulting from the shorter straight members **322** will be situated at a distance slightly shy of the vertices **312** resulting from the convergence of the longer straight members **320**. The vertices **312** formed by the shorter straight members **322** merge into distally directed extensions **12Q** and the vertices **312** formed by the longer straight members **320** merge into distally directed extensions **118**. It is contemplated that this staggered configuration will assist in closing off the terminal end **29** (distal end) of the filter (as will be discussed hereinafter.)

In this configuration, the first and second member sections **95** and **96** of the distal section **26** are configured to “fan-in” distally such that at each distal end of each member section, there is half the number of converging vertices available for distally successive member sections of the distal section **26**. Therefore, moving distally from the proximal end **28** of the distal section **26**, the straight members **102** of the first member section **95** includes sixteen proximal end points **302** and converge to form eight vertices **304** forming the distal end **303** of the first member section. The straight members **110** of the second member section **96** includes eight proximal end points **310** forming the eight vertices **304** of the first member section **95** and converge to form four vertices **312** forming the distal end of the second member section. Finally, the four distal vertices **312** of the second member section **96** converge to distally directed straight members **118** and **120**.

The straight members **110** of the distal portion **26** define an open-ended, distally directed vee **116** sandwiched between a plurality of diamond-shaped apertures **98** and **104**. A distal convoluted ring **101** defined by members **102** is located proximally adjacent the distal end portion **26** defining the distal end portion **26** proximal end **28**. The ring **101** provides for maximal radial opening of the body **22**. Distally directed extensions **118** and **120** project, in a parallel fashion, from the vertices defined by the plurality of converging straight members **110**.

The distally directed straight members **118** and **120** of the filter distal portion **26** are joined together to form a substantially closed filter. This structure can be joined using soldering or by employing a coil (as will be described hereinafter) that is wrapped about the distally directed extensions **118** and **120** to form a soft tip. The distally directed extensions **118** and **120** may also be trimmed to a desired length. Alternatively, as discussed above, because the distally directed extensions **120** extend from two shorter length vertices **312** of the second member section **96**, they may be inserted (tucked) into the two longer vertices **312** of the second member section **96** (not shown). This insertion eliminates the need to include a further level of convergence leaving only two distally directed extensions **118**.

Referring to FIG. 6, the mid-section **54** of the filter pattern **52** includes generally a first ring **70**, a second ring **80** and a third ring **90**. In its manufactured form, the rings **70**, **80**, and **90** of the filter mid-section **54**, together, form a generally tubular mid-section. Each ring **70**, **80**, **90** includes a plurality of straight members **72**, **82**, and **92** respectively. The straight members of each ring are in an alternating V-pattern configuration to form a plurality of apices defining a proximal end and a distal end of each ring. Hence, straight members **72** of the first ring **70** includes a plurality of apices **71** defining a proximal end **271** and apices **73** defining a distal end **273** of the first ring **70**. Similarly second ring **80** includes proximal apices **81** and distal apices **83** and third ring **90** includes proximal apices **91** and distal apices **93**. The

rings meet each other at the apices, the first ring **70** meets the second ring **80** at connection **75** between distal apices **73** of the first ring and proximal apices **81** of the second ring. Similarly, the second ring **80** meets the third ring **90** at connection **85** between distal apices **83** of the second ring and proximal apices **91** of the third ring.

The filter mid-section **54** may join the filter proximal section **24** such that each of the distal end points **265** of straight members **64** of the filter proximal section **24** are joined at an angle to the proximal apices **71** of the first ring **70**. Similarly, the filter mid-section **54** may join the filter distal section **26** such that the distal apices **93** of the third ring **90** are joined at an angle to the proximal open-ended end points **302** of the straight members **102** of the filter distal section **26**. In this configuration, the filter proximal section **24**, mid-section **54**, and distal section **26** form a generally tubular filter device in its manufactured form (see FIG. 7).

It is contemplated that in one preferred embodiment, each distally successive alternating V-pattern ring **70**, **80** and **90** may be configured to be shorter in length than the ring situated proximally to itself, for example ring **90** may be shorter in length than ring **80**, which in turn, may be shorter in length than ring **70**. The progressive shortening of ring lengths provides for a conical tapering of the filter from the proximal to the distal ends. This conically tapered configuration may enhance foreign body containment because the progressive shortening of the rings **80** and **90** translate into a progressive decreasing of the sizes of the apertures located within the distal portions of the filter mid-section **54**, which, as discussed above, ultimately closes off at the filter distal section **26** to form a substantially closed filter device. Additionally, the tapered configuration may provide greater flexibility around bends found in the human vasculature.

Referring now to FIG. 7, the members **50**, **60** and **64** form a tapered opening **32** to the generally tubular mid-section **54** with the elongate member **30** extending proximally from a sidewall defined by the mid-section **54**. It is contemplated that the resultant tubular structure, in an undeformed state, includes a longitudinal axis that is parallel to both the elongate member **30** and the distally directed projections **118** and **120**.

Another way to describe the basket device is that it begins with a proximal elongate member linked to a series of divergent branches of increased density covering varying fractions of the tubular circumference. The divergent branches wrap around the circumference from the side where the elongate member ends to form the tube. Linked from the divergent branches is one or more ring segments. Branching from the ring segment is a series of convergent branches covering varying fractions of the tubular circumference. This section is tapered down to the distal tip to reduce the required coverage area thus maintaining adequately small openings for encapsulation.

Although each of the first, second, and third rings **70**, **80** and **90** of the body mid-section **54** have been shown as embodying a sixteen apex design having thirty-two straight members **72**, **82**, and **92** respectively, configured in an alternating V-pattern, as will be described below, designs having fewer or more apices with fewer or more straight members are contemplated. Such design modifications may produce enhanced qualities for the desired uses of the current invention and it will be understood that such modifications in the filter design will not depart from the scope of the present invention.

The porosity of the filter can be varied by increasing or decreasing the length and number of straight members of

each ring **70**, **80**, and **90**. In some instances there may be a need or desire to capture smaller foreign matter or emboli, therefore, it may be desirable to decrease the porosity of the filter for use under such circumstances. In order to decrease the porosity of the filter, either the lengths of the straight members of each ring **70**, **80**, and **90** may be decreased, or the number of straight members may be increased. As discussed above, by increasing the number of straight members, the body mid-section may result in a design having a higher number of apices.

Moreover, in any alternative design there need not be straight members **50**, **60**, and **64**, extending from each proximal apices **71** of the first ring **70**. It is necessary, however, that as with the ring design depicted, the modified pattern also result in rings that provide a complete open deployment consistently and reliably. To wit, such rings do not fall back. That is, there is no angular deflection when the structure is engaged upon a clot or foreign body.

In order to have the device collapse evenly, all continuous (not recursive) paths from the first divergence to the last convergence of members can be of approximately the same length. In that way, during collapse less buckling may occur in the longer members and the shorter members may not be required to stretch to achieve a substantially linear constrained configuration.

Referring now to FIG. 8, there is shown one preferred embodiment of the elongated member **30** of the present invention. The member **30** embodies a gradual or step-tapered core comprising a proximal section of **304V** stainless steel and a distal section of nitinol or an equivalent material for the intended purpose. A proximal portion **200** of the member **30** has a generally constant cross-sectional profile and a first diameter **201**. At a transition point **202**, the member **30** begins to taper in a gradual and consistent, manner, or alternatively in a step-tapered or in a parabolic or other non-linear manner, from the first diameter **201** to a second diameter **203** along a distal end portion **204**.

As shown in FIGS. 9 and 10, a pair of longitudinally adjacent arranged coils **206**, **208** are employed to attach a proximal tab **53** of a filter device **20** to the distal end portion **204** of the elongate member **30**. The first, proximal coil **206** is contemplated to be composed of **304V** stainless steel, the first coil being soldered to the elongate wire **30** near its tapered portion **210**. The second coil **208** is contemplated to embody a medical grade radiopaque wire, typically a platinum alloy such as about 90% platinum and 10% iridium alloy. This second coil **208**, which serves as a radiopaque marker, is soldered to the elongate member **30** near a distal end portion **212** of the first coil **206**. Alternatively, the second coil **208** is soldered to the first coil **206**. A proximal tab **53** of the filter device **20** is contained within the second coil **208** and is soldered **216** to the elongate member **30**. (FIG. 10)

Turning now to FIGS. 11–13, one presently preferred embodiment of a distal tip portion of the filter device **20** of the present invention is described. The distal tip portion embodies two partially coaxial coils **222** and **224**, the combination of which retains the distally directed extensions **120** and **118** projecting from the body of the filter device **20** (see FIG. 7). The combination also provides a soft atraumatic tip with variable stiffness from softest distally to stiffer proximally. It is to be recognized that by varying the length of the tip and/or the coils **222**, **224**, changes in stiffness can be achieved to produce a tip with a desired flexibility.

The inner coil **222** is comprised of nitinol or equivalent material, and begins at a proximal location **226** and extends

to a distal location **228**. The nitinol inner coil **222** provides kink resistance as well as creates a smooth stiffness transition from the tip of the filter portion of the filter device **20**. The outer coil **224** is coaxially configured about a distal portion **230** of the inner coil **222** and is preferably comprised of 90% platinum and 10% iridium alloy or an equivalent combination of materials. As such, the outer coil **224** can operate as a radiopaque marker. The distal tip portion **27** further includes a rounded terminal end **232** that provides a blunt atraumatic surface. The terminal end **232** embodies a soldered joint which acts in retaining the helical configuration of the outer coil **224**.

With reference to FIGS. **14** and **15**, a brief summary of the process used to manufacture the filter devices **20** of the present invention will be discussed. As shown in FIG. **7**, the preferred embodiment in its as cut configuration is relatively similar to the other alternative embodiments discussed above and includes a sixteen (16) apex, three ring pattern **52**. It is contemplated that the filter devices **20** of the present invention be cut from a tube **240** (FIGS. **14** and **15**) using a laser. In particular, a specific pattern is programmed into the laser device and the laser is activated to cut the desired pattern into the tubular element **240**. The excess tubular components are removed, thereby leaving a manufactured structure such as the filter pattern **52** shown in FIGS. **14** and **15**, corresponding to the desired pattern. In a presently preferred embodiment, a super elastic material such as nitinol may be a material of choice for the filter device **20**. Thereafter, post-processing such as surface treatment, burr removal, oxide removal, and shape setting of the manufactured structure is performed. Heat treating is also performed for stress relief of the device.

In particular, post-processing steps include taking an as-cut device and bead blasting the device with aluminum oxide blasting media. The device is then inspected under a microscope for residual slag. If slag remains, the device is bead blasted again. Thereafter, the device is stress-relieved in a molten salt bath without expanding. The device is subsequently heat-expanded in a molten salt bath mounted on a suitable size mandrel. After heat expansion, surface oxidation is removed in an aqua regia bath. When nitinol is the material of choice, the nitinol is etched with HF solution to desired strut size resulting in desired softness. The device is then mounted on a guidewire, using coils and solder.

In the case of the pattern **52**, the post-processing may include deforming the pattern **125** and then joining together the distally extending members **118** and **120** for the purpose of achieving a closed filter for receiving and containing debris found in the patient's vasculature. Being so configured, the pair of diverging members **50** define an opening to the resultant filter and the elongate member **30** extends from a sidewall defined by the opening.

The filter devices of the present invention provide improved radial opening compared to prior art filter devices since in an expanded state, the elongate member **30** is positioned substantially out of the flow path. Additionally, the current invention embodies improved resistance to radial and axial loads as compared to prior art filter devices. Moreover, since less deformation is required to produce a desired filter pattern, in that, angles between members are provided by laser cutting rather than from local deformations, for example, there is potentially improved stress distribution along the filter devices of the present invention compared to prior art filter devices. Additionally, a greater reduction in radial profile can be achieved without sacrificing performance and in particular, the device can be used in conjunction with microcatheters. As such, the filter

devices **20** of the present invention can be passed through narrow and tortuous vasculature. The applications of the present invention are more widespread than that of conventional filter devices because of greater retrieval and capture characteristics while retaining the deliverability characteristics.

The above described invention is principally conceived to be operational during treatment of vessels, for use in capturing and maintaining for the purpose of displacing and/or removing material either foreign or native to the body, which may occur during or as a result of intravascular treatment within intraluminal or extraluminal spaces of the body including but not limited to intravascular and/or intra-arterial regions of the cerebral vasculature. The purpose of the device is to ensure and maintain functionality of the luminal space or systems dependent on the particular luminal space or as a method of producing any desired effect associated with the removal or displacement of undesirable material.

The intended delivery of the disclosed invention is by means of a commercially available catheter selected for its ability to access the desired location of engagement. The invention may be optimized for specific locations or uses by means of sizing the individual elements in the design and/or the overall dimensions, as well as selection of materials, mesh configuration, number and relative geometry of component members to meet the requirements of the operational space. Optimizations may include variations of the dimensions of length, thickness, and width of distal and proximal tabs for joining filter with delivery wire and distal tip to provide smooth stiffness transitions from tip to filter and filter to delivery wire. Such optimizations are means of adjusting operational attributes including: flexibility, applied circumferential force, engagement effectiveness, deliverability and traversal through tortuous vasculature, and volume of material to be engaged.

Alternate or additional materials for the filter portion of the device may include a shape memory polymer, thermoset, elastomer, thermoplastic constituents such as nylon, or other metal either pure or alloyed, as well as composite materials such as a combination of glass, aramid, or carbon in a binding matrix. A secondary mesh of the same or dissimilar material may be added to the filter. The wire portion of the device can alternatively be made from a single metal or combination of metals for kink resistance and high flexibility. Either or both components may be tapered to give a transition in stiffness that is appropriate for the vessel in which the invention is to be delivered. The distal tip of the device may incorporate concentric coils made of nitinol, stainless steel, or other metal or plastic to provide a soft flexible atraumatic end. As stated, the members defining a body of the disclosed devices can have various shapes including but not limited to curves, arcs, S-shapes, partial straight sections or any combination thereof. The same can be used to achieve desired or enhanced compression or deployment characteristics.

An alternate method of manufacture of the filter portion of the device may be photo-etching, or metal or polymer injection molding or water jet cutting. Furthermore, the device may employ any combination of coatings, agents, or features including those that result from material addition or subtraction to create grooves, bumps, three dimensional patterns, and textures on inner and/or outer surfaces or any combination thereof to promote desired properties such as adherence of materials to be engaged, radiopacity, and low friction between the device and the vessel wall or microcatheter lumen.

In summary, the invention is deliverable to the carotid artery or remote regions of the vasculature by gaining access through the use of a guidewire and microcatheter in the vasculature and subsequent deployment of the invention through the lumen of the microcatheter. During treatment of the vessel, the device is deployed downstream of the treatment site by withdrawing the microcatheter relative to the wire. Engagement occurs as the system composed of the invention and microcatheter is expanded against the vessel wall slightly offset of, and as mentioned above, downstream of the treatment site. After deployment of the filter device, treatment may commence and any foreign or naturally occurring materials which may result from the treatment will be captured by the device as the material flows freely with the stream of blood into the body of the filter device. Subsequent to completion of the treatment, removal of the material is accomplished by withdrawing the system into a guide catheter lumen through which the microcatheter is passed with or without simultaneously pulling fluid through the guide lumen.

Thus, it will be apparent from the foregoing that, while particular forms of the invention have been illustrated and described, various modifications can be made without departing from the spirit and scope of the present invention. Accordingly, it is not intended that the invention be limited, except as by the appended claims.

What is claimed is:

1. A filter device, comprising:

an elongate member having a first end and a second end, the second end extending exterior of the vasculature;

a body including a first section defining a first end portion, a second section defining a mid-portion, a third section defining a second end portion, the first section, the second section and the third section form a conically tapering filter, the body includes an open first end and a substantially closed second end;

the body having a longitudinal axis defined by a sidewall, the body being attached to the second end of the elongate member, the elongate member extending from the open first end in a parallel relationship with the longitudinal axis; and

the mid-portion further comprising three ring members adjacently configured end to end, each ring member having a plurality of first members in an alternating V-pattern to form sixteen apices defining each a ring proximal end and a ring distal end.

2. The device of claim 1, wherein the body has a compressed configuration and an expanded configuration.

3. The device of claim 1, the first end portion of the body further comprising at least one member section having a plurality of second members, the second members each having a proximal end and a distal end, the second members are pair-wise in a V-shape having converging vertices defining a proximal end and open-ended branch ends defining a distal end of the member section.

4. The device of claim 3, the first end portion further comprising a pair of undulate members, each of the undulate members having a first end and a second end, the first end of the undulate members converge to form a tab, the tab being affixed to the second end of the elongate member, the second end of the undulate members being affixed to the vertices of the member section proximal end.

5. The device of claim 1, the second end portion of the body further comprising at least one member section having a plurality of straight members, the straight members each having a proximal end and a distal end, the straight members

are pair-wise in a V-shape having open-ended branches defining a proximal end and converging vertices defining a distal end of the member section.

6. The device of claim 5, the second end portion of the body further comprising a plurality of distally extending members, the distally extending members are proximally joined with the converging vertices of the distal end of the member section.

7. The device of claim 6, the distal tip further comprising a coil coaxially arranged about the extending members.

8. The device of claim 6, the distal tip portion further comprising a blunt terminal end formed from a soldered joint.

9. The device of claim 1, the mid-portion further comprising at least one ring member.

10. The device of claim 1, the device further comprising a generally tubular delivery catheter, the delivery catheter including an internal lumen sized to slidably receive the elongate member and the body.

11. The device of claim 1, wherein the device is fabricated from a tubular element using a laser.

12. The device of claim 1, wherein the device is made from self-expanding, superelastic, or shape memory material.

13. A medical device for treating an interior of a patient, comprising:

a body, the body including a first portion having first and second ends, a mid-portion having a ring member, the ring member having a first and second end, the first end of the ring member joined the second end of the first portion and a second portion having a first and second end, the first end of the body second portion with the second end of the ring member, the second end of the body second portion defining a closed terminal end of the body;

the ring member having a plurality of first members in an alternating V-pattern forming sixteen apices at each of the ring first end and second end; and

an elongate member having a first end portion and a second end portion, the second end portion being affixed to the first end of the body first portion and the elongate member first end portion extending exterior of the patient.

14. The device of claim 13, wherein the body first portion provides an opening to an interior of the body.

15. The device of claim 14, the body first portion further comprising two undulate members, each having a first and second end, the undulate members first end converge into a single tab member, the tab member projecting from a sidewall defining the opening and is connected to the elongate member second end portion.

16. The device of claim 15, the body first portion further comprising first, second and third straight member sections, each member section having a plurality of straight members having a first end and a second end and pairs of straight members in a V-shape such that at a proximal end of each straight member section, a pair of straight members converge at their first end to form a vertex and at a distal end of each straight member section, the second end of the straight members form open-ended branch ends.

17. The device of claim 16, wherein the first straight member section includes four straight members forming two proximal vertices and four distal open-ended branch ends, the second member section includes eight straight members forming four proximal vertices and eight distal open-ended branch ends and the third member section includes sixteen straight members forming eight proximal vertices and six-

17

teen distal open-ended branch ends, the two proximal vertices of the first straight member section are joined with the second ends of the undulate members, the four distal open-ended branch ends of the first straight member section are joined with the four proximal vertices of the second straight member section, the eight distal open-ended branch ends of the second straight member section are joined with the eight proximal vertices of the third straight member section, the sixteen distal open-ended branch ends of the third straight member section are joined with the body mid-portion.

18. The device of claim 17, wherein the ring member is self-expanding and operates to provide a consistent opening to an interior to the body.

19. The device of claim 18, wherein the straight members of the first ring member, the second ring member and the third ring member have an equal first length.

20. The device of claim 18, wherein the straight members of the first ring member have a first length, the straight members of the second ring member have a second length and the straight members of the third ring member have a third length, the first length being longer than the second length and the second length being longer than the third length.

21. The device of claim 17, wherein each of the straight elements of the ring member have an approximate equal first length.

22. The device of claim 17, the mid-portion further comprising second and third ring members, each of the second and third ring members having a plurality of straight members in an alternating V-pattern forming sixteen apices at the first and second ends of each ring, the first, second and third ring members consecutively merge with the apices to form the mid-portion such that the apices of the first ring member mate with the apices of the second ring member proximal end and the apices of the second ring member mate with the apices of the third ring member.

23. The device of claim 17, the body second portion further comprising first and second straight member sections, each member section having a plurality of straight members having a first end and a second end and pairs of the straight members in a V-shape such that at a proximal end of each straight member section, the straight members form open-ended branch ends and at a distal end of each straight member section, a pair of straight members converge to form a vertex.

18

24. The device of claim 23, wherein the first straight member section includes sixteen straight members forming sixteen proximal open-ended branch ends and eight distal vertices, the second member section includes eight straight members forming eight proximal open-ended branch ends and four distal vertices, the sixteen proximal open-ended branch ends of the first straight member section merge into the body mid-portion second end, the eight distal vertices of the first straight member section merge into the eight proximal open-ended branch ends of the second straight member section.

25. The device of claim 24, the body second portion further comprising four distally extending members merged to the four distal vertices of the second straight member section, the four distally extending members have an approximately equal length.

26. The device of claim 23, wherein the second straight member section include four straight members having a first length and four straight members having a second length, the first length being longer than the second length.

27. The device of claim 26, wherein the eight straight members of the second straight member section are in a V-shape to form eight proximal open-ended branch ends and four distal vertices, two distal vertices formed from the straight members having the first length will be longer than the two distal vertices formed from the straight members having the second length, the eight proximal open-ended branch ends of the second straight member section merge with the eight distal vertices of the first straight member section.

28. The device of claim 27, the body second portion further comprising four distally extending members merged with the four distal vertices of the second straight member section, the two distally extending members joined with the two shorter vertices of the second straight member section are tucked within the longer vertices of the second straight member section, the distally extending members joined with the longer vertices are connected to form a distal tip.

29. The device of claim 28, the distal tip further comprising a coil coaxially arranged about the extending members having the first length.

30. The device of claim 13, wherein the body is cut from a tube.

* * * * *

UNITED STATES PATENT AND TRADEMARK OFFICE
CERTIFICATE OF CORRECTION

PATENT NO. : 6,551,342 B1
DATED : April 22, 2003
INVENTOR(S) : Christopher T. Shen et al.

Page 1 of 1

It is certified that error appears in the above-identified patent and that said Letters Patent is hereby corrected as shown below:

Column 15,
Line 30, change "second", to read -- first --.

Signed and Sealed this

Nineteenth Day of August, 2003

A handwritten signature in black ink, appearing to read "James E. Rogan", with a horizontal line drawn underneath it.

JAMES E. ROGAN
Director of the United States Patent and Trademark Office