



US006547945B2

(12) **United States Patent**
Shallow et al.

(10) **Patent No.:** US 6,547,945 B2
(45) **Date of Patent:** Apr. 15, 2003

(54) **METHOD AND APPARATUSES FOR ELECTROCHEMICALLY TREATING AN ARTICLE**

(75) Inventors: **Christopher T. Shallow**, West Hartford, CT (US); **Robert B. Parrish**, Waterford, MI (US)

(73) Assignee: **United Technologies Corporation**, Hartford, CT (US)

(*) Notice: Subject to any disclaimer, the term of this patent is extended or adjusted under 35 U.S.C. 154(b) by 61 days.

(21) Appl. No.: **09/754,595**

(22) Filed: **Jan. 5, 2001**

(65) **Prior Publication Data**

US 2002/0046951 A1 Apr. 25, 2002

Related U.S. Application Data

(60) Provisional application No. 60/221,771, filed on Jul. 31, 2000.

(51) **Int. Cl.**⁷ **C25D 7/04**; C25D 17/00; B23H 3/00; C25B 9/00

(52) **U.S. Cl.** **205/151**; 205/668; 205/672; 204/272; 204/275.1; 204/273; 204/224 M; 204/224 R

(58) **Field of Search** 204/272, 275.1, 204/273, 224 R, 224 M; 205/148, 151, 668, 672

(56) **References Cited**

U.S. PATENT DOCUMENTS

1,982,009 A	*	11/1934	McKinney et al.	204/272
3,905,885 A	*	9/1975	Bengel et al.	204/272
4,246,088 A	*	1/1981	Murphy et al.	204/199
5,176,803 A	*	1/1993	Barbutto et al.	204/237
5,861,087 A	*	1/1999	Manning	204/272
5,873,986 A	*	2/1999	Thompson et al	204/237
6,267,855 B1	*	7/2001	Watanabe et al.	204/228.3
6,383,348 B2	*	5/2002	Kuroda et al.	204/224 M

* cited by examiner

Primary Examiner—Nam Nguyen

Assistant Examiner—Thomas H. Parsons

(74) *Attorney, Agent, or Firm*—Gene D. Fleischhauer

(57) **ABSTRACT**

An electrochemical cell for use in electrochemical processes, such as plating processes, has a first electrode which extends circumferentially about at least a portion of an electrode chamber. The article being treated is the second electrode and is disposed within the chamber. Electrolyte is flowed between the two electrodes. Various construction details of the electrochemical cell are developed which facilitate a plating process. In one embodiment, a supply conduit to the electrode chamber has a swirler.

18 Claims, 3 Drawing Sheets

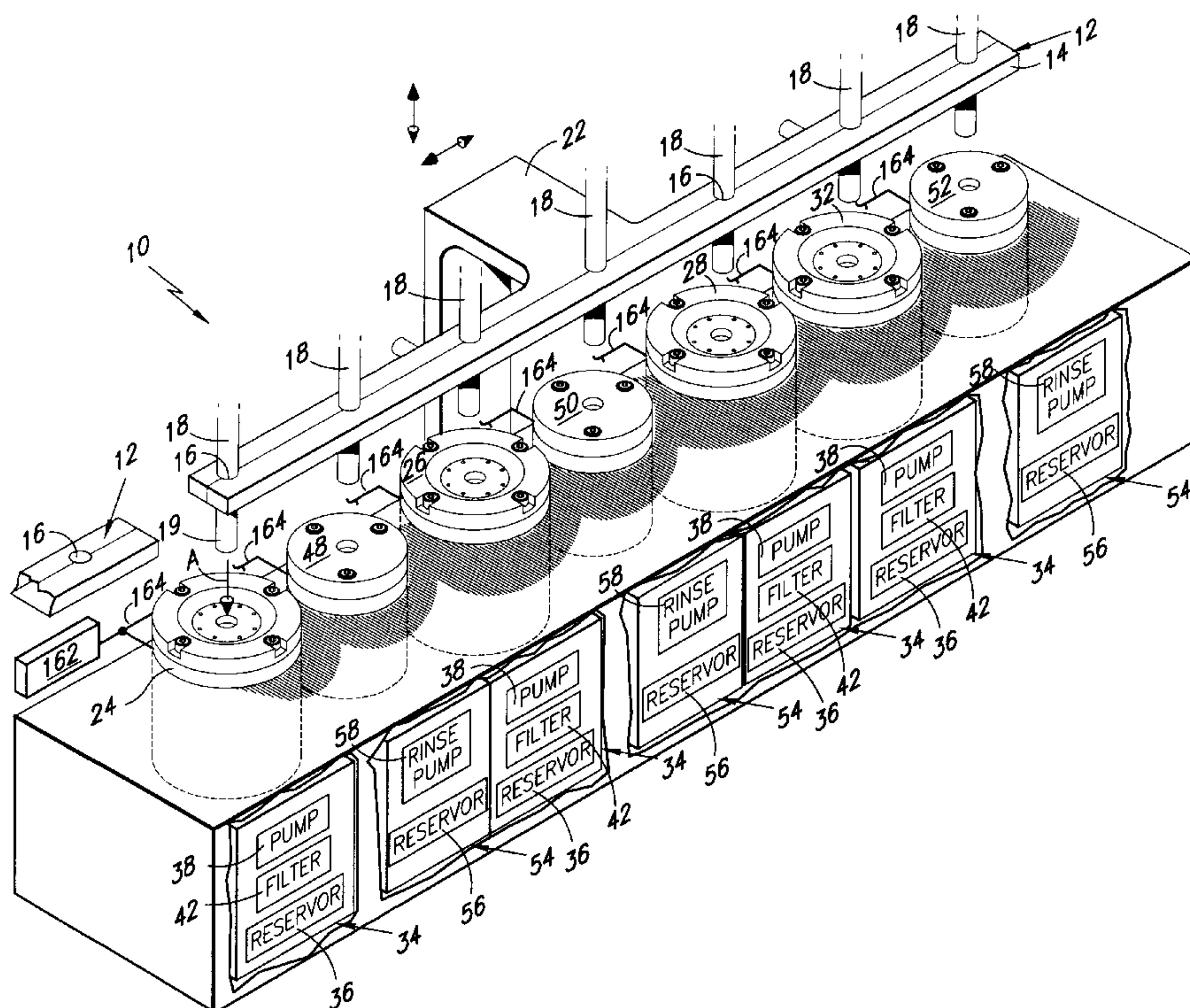

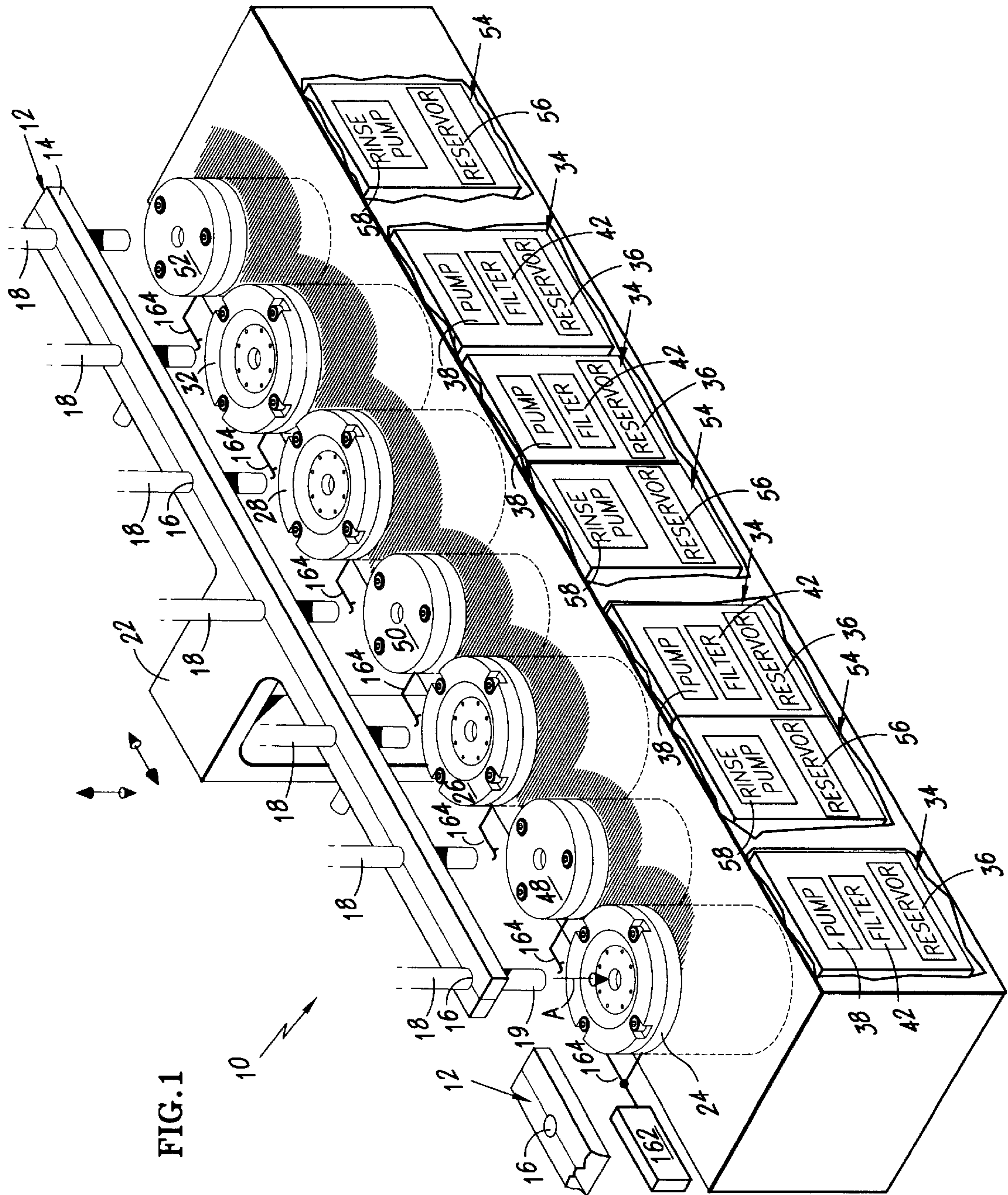

FIG. 1

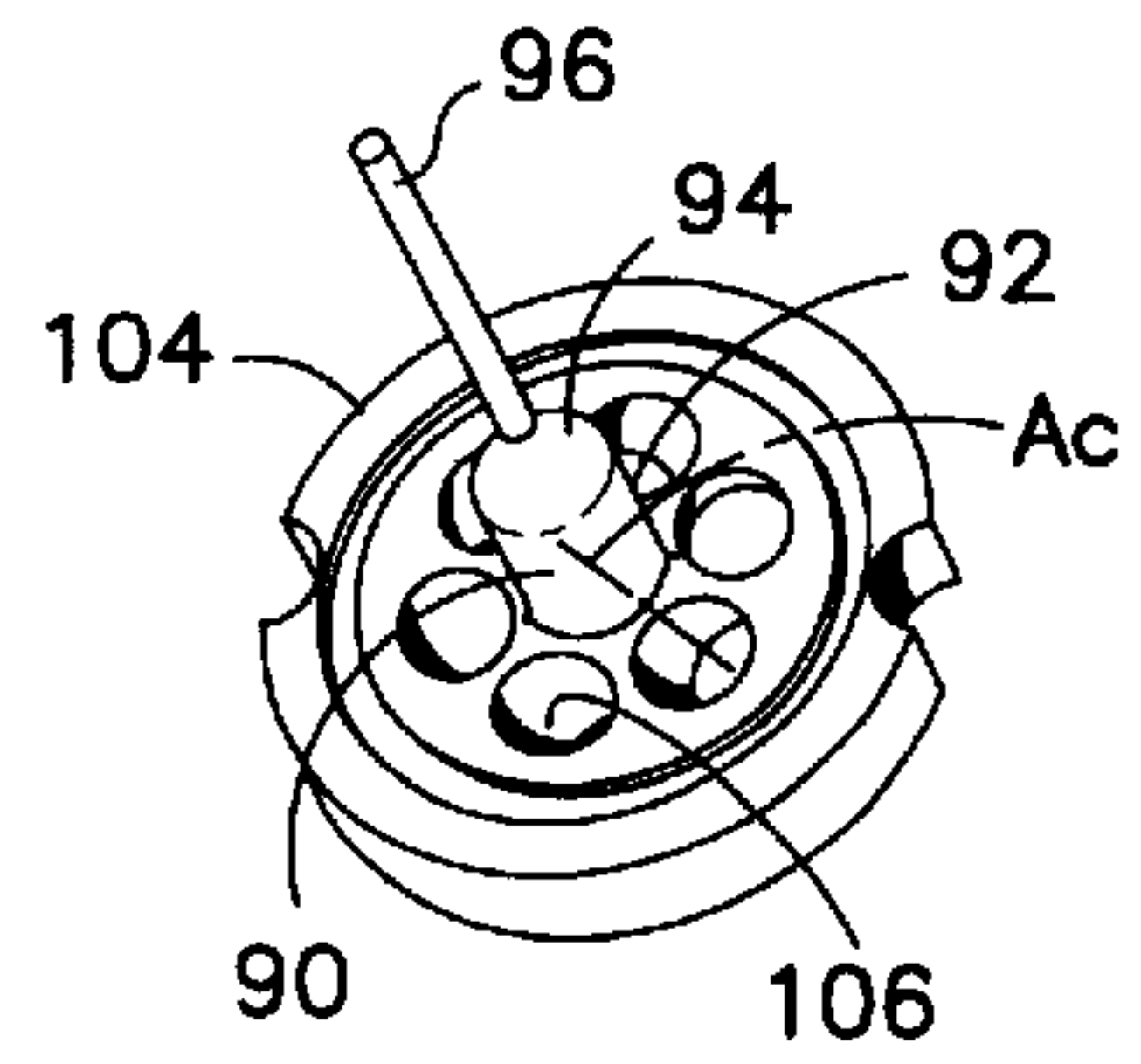
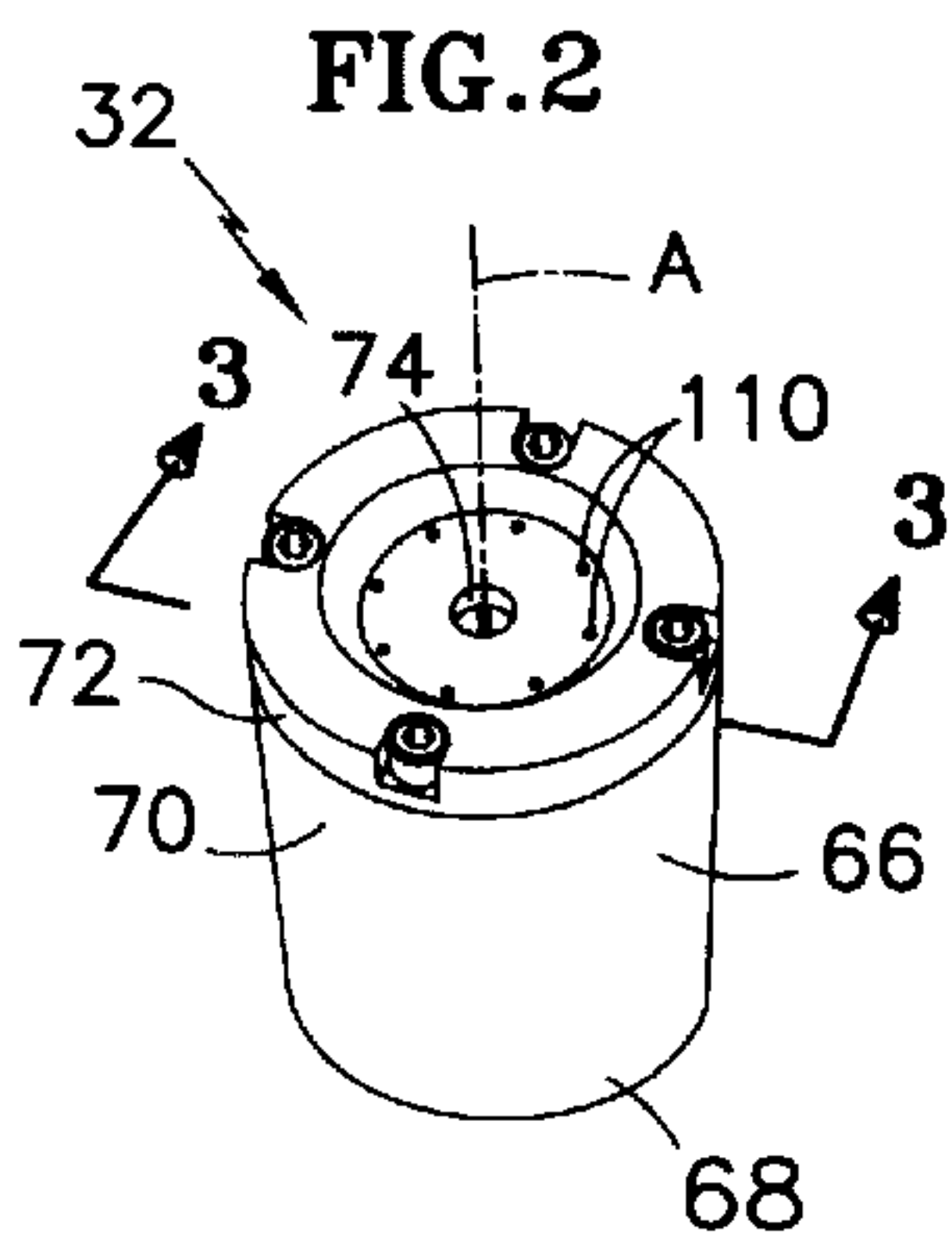

FIG. 4

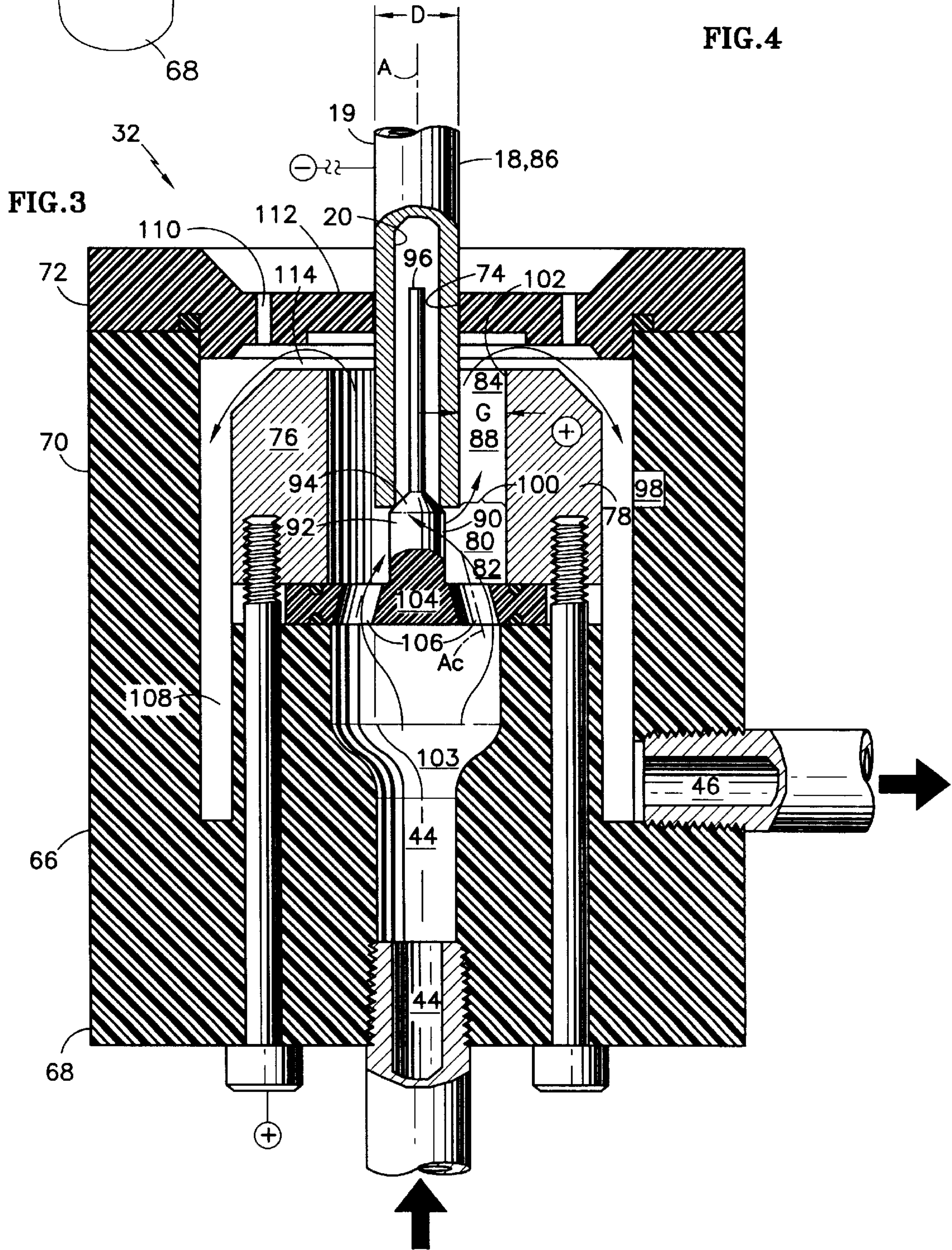

FIG. 3

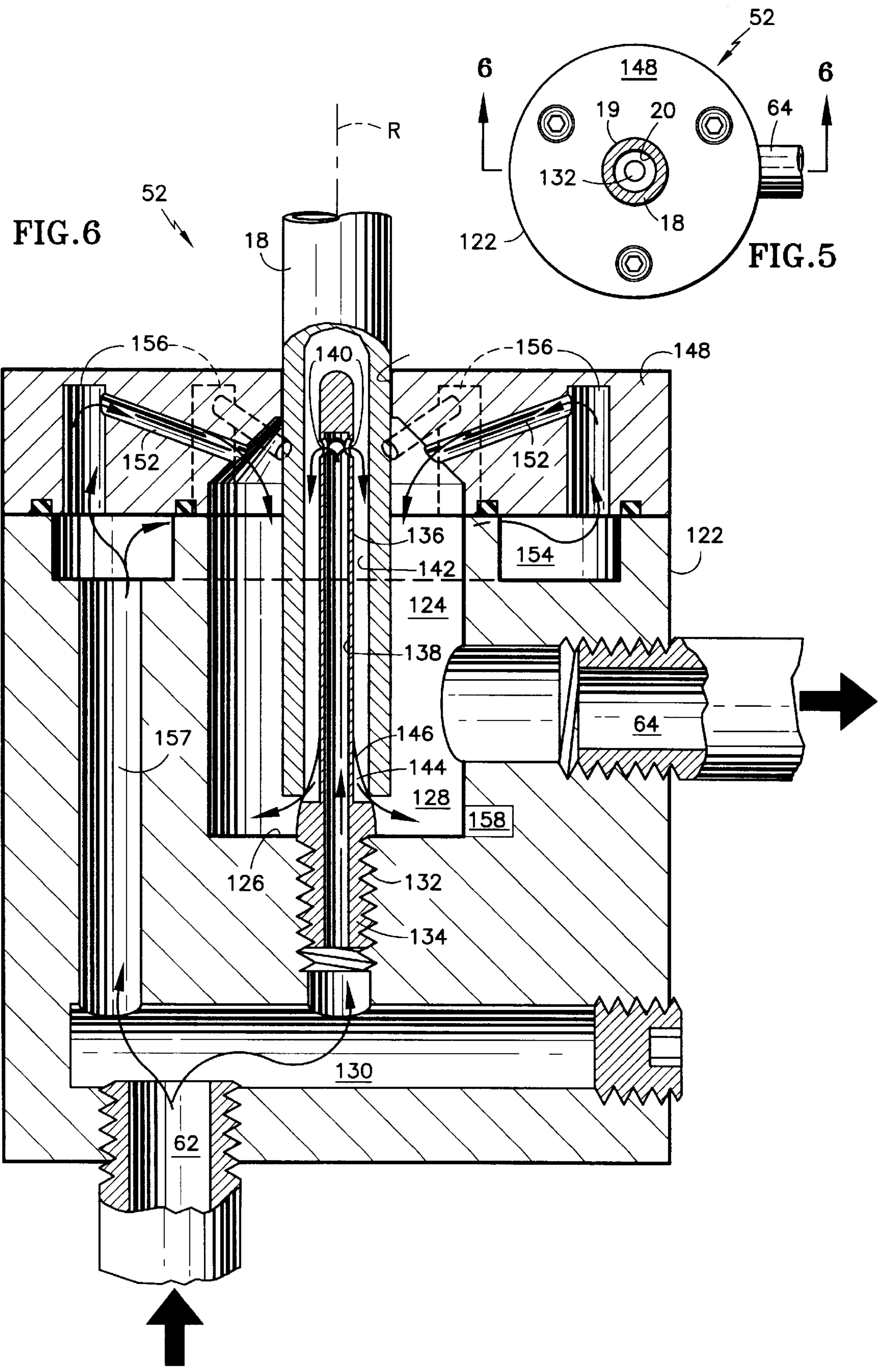

FIG. 6

FIG. 5

METHOD AND APPARATUSES FOR ELECTROCHEMICALLY TREATING AN ARTICLE

CROSS-REFERENCE TO RELATED APPLICATIONS

This application claims the benefit from U.S. Provisional Application Ser. No. 60/221,771 filed on Jul. 31, 2000.

The subject matter of this application is related to the subject matter of U.S. patent application Ser. No. (EH-10266) filed on even date herewith by Parish et al. entitled "Method for Electrochemically Treating Articles and Apparatus and Method for Cleaning Articles."

BACKGROUND OF THE INVENTION

1. Technical Field

This invention relates to a method for electrochemically processing articles, such as cylindrically shaped, hollow tubing articles, and more specifically, to methods and to apparatuses used for plating processes.

2. Description of the Related Art

One example of hollow articles requiring plating is tubing used in the aerospace field. The tubing is used for flowing fuel, lubricating fluid, hydraulic fluid and the like, typically in high-pressure applications. The tubing is relatively small in diameter (less than one inch) and is typically joined to a mating component using braze material. The tubing frequently receives a coating to provide a smooth surface. The coating is carefully applied because the coated tubing has controlled tolerances. The smooth surface and controlled tolerances ensure that capillary forces will urge the braze material to flow into a predetermined gap between the tubing and the component.

One approach for providing the coating uses a plating process having a large-scale bath and includes disposing many pieces of tubing in the bath. A large-scale plating bath may not efficiently use the plating solutions, increasing purchasing costs and increasing disposal costs of the environmentally sensitive waste. Depending on the location of the tubing in the bath, the tubing might receive a thicker than desired coating or a thinner than desired coating. In addition, a large-scale plating bath may well be located at a site remote from the location at which the brazing processes are carried out.

Another approach for providing the coating is a brush plating process. The electrolytes used for brush plating have a higher metal content than electrolytes for conventional plating baths. Brush plating processes employ a carbon anode wrapped in a conductive pad. The conductive pad is soaked in the electrolyte. This is essential to achieve higher rates of plating deposition. A current is passed through the pad and to the article as the operator rubs the pad over the surface.

An advantage of the brush plating process is little waste and acceptable levels of time for work in process. However, the process is labor-intensive and variations in technique from operator to operator increase the difficulty of precisely controlling the plating thickness. In addition, the operator must handle harsh chemicals during cleaning and etching and must hold and move the anode with a repetitive motion that causes fatigue and which might cause repetitive motion injuries.

Accordingly, scientists and engineers working under the direction of Applicants Assignee have sought to develop a plating process and apparatus for use with such processes

that provide efficient use of solutions, efficient use of rinsing water and may be installed in local work areas.

BRIEF SUMMARY OF THE INVENTION

5 This invention is predicated in part on the recognition that using concentrated solutions of the type having higher metal content for use with high-speed plating may advantageously be used in local work areas by using dedicated plating cells. It is also predicated on recognizing that dedicated cells may be provided with flow patterns that promote rinsing processes and electrochemical processes associated with plating. In this context, electrochemical processes refer to process steps for an article, such as etching, activating and electroplating and other steps that pass a current through an electrolyte. The current is passed between a pair of electrodes where the article acts as one of the electrodes, whether as an anode or a cathode. Rinsing refers to those steps using an apparatus to prepare the surface by removing contaminants from the surface with a rinse fluid, such as by removing electrolyte from the surface with rinse water.

According to the present invention, an electrochemical cell for performing an electrochemical process includes a first electrode having an electrode chamber for receiving electrolyte and an article which forms the second electrode and which is disposed inwardly of the first electrode and spaced from the first electrode leaving a passage for electrolyte therebetween. In accordance with the present invention, the electrolyte passage is in flow communication with a source of electrolyte to flow electrolyte to the electrolyte passage during the electrochemical process.

In accordance with one detailed embodiment of the present invention, means for swirling the electrolyte is disposed in the electrochemical cell for imparting a lateral or circumferential velocity to the electrolyte as the flow passes to electrolyte passage.

In accordance with one detailed embodiment, the electrochemical cell has a guide member for guiding the article as the article is inserted into the electrochemical cell.

In accordance with one embodiment, the guide member is disposed within the electrode chamber and the article extends about the guide member. According to another embodiment, the first electrode extends circumferentially about an axis A to form a circumferentially extending chamber and the second electrode (the article) is a circumferentially extending object which is spaced from the first electrode leaving an annular electrolyte passage therebetween.

According to the present invention, a method of electrochemically treating an article using a pair of electrodes includes: disposing a first electrode about the article to form at least a portion of the chamber for receiving an electrolyte; disposing electrolyte in the chamber; disposing the article in the electrode chamber to form the second electrode and placing the second electrode in electrical communication with the first electrode; and, passing electrical current between the electrodes to electrochemically affect a surface of the article.

In accordance with one embodiment of the present invention, the method includes flowing additional electrolyte into the electrode chamber and displacing electrolyte from the electrode chamber during the step of passing an electrical current through the electrolyte.

In one detailed embodiment, the method includes flowing additional electrolyte into the bottom of the electrode chamber and overflowing electrolyte from the top of the electrode chamber.

In accordance with one embodiment, the method includes bounding the electrode chamber with an electrode, disposing the article in the center of the chamber; flowing electrolyte through the bottom of the electrode chamber and flowing electrolyte upwardly with a circumferentially directed component of velocity about the article to block the formation of current induced variations in the concentration of the electrolyte.

In accordance with one detailed embodiment, the article is a tubing and the anode chamber has a cylindrical wall.

A primary feature of the present invention is an electrochemical cell having a first electrode which extends about at least a portion of an electrode chamber. Another feature is a second electrode which is the article being processed. The second electrode is disposed inwardly of the first electrode leaving an electrolyte passage therebetween. In one embodiment, the electrolyte passage is in flow communication with a conduit for supplying electrolyte and removing electrolyte under operative conditions. In one detailed embodiment, a feature is the supply conduit which has a diffusion region and a swirler disposed upstream of the electrode chamber.

A primary advantage of the present invention is the efficiency of the process which results from using dedicated cells having small volumes of fluid for repetitively performing a plating operation. Another advantage is the ability to use such cells in a relatively small area compared to large plating baths, with the small area enabling locating the array of cells adjacent to the area for the next operation on the article, such as having a plating apparatus in close proximity to an area which performs brazing. Another advantage is the quality of the coating which results from the method of flowing electrolyte through the coating apparatus to reduce current induced variations in electrolyte concentration. In one embodiment, an advantage is the quality of the coating which results from disposing an electrode about the article at a uniform distance from the surface of the article receiving a coating. Another advantage is the quality of the coating which results from disposing the coated article within the electrode and avoiding structure between the article and the first electrode. In one embodiment, an advantage is the avoidance of short-circuits as the article is inserted into the electrode chamber which results from using a guide member to position the article in the electrode chamber, the guide member not interfering with the passage of electrical current between the first and second electrodes.

The foregoing features and advantages of the present invention will become more apparent in light of the following detailed description of the best mode for carrying out the invention and accompanying drawings.

BRIEF DESCRIPTION OF THE DRAWING

FIG. 1 is a perspective view of an apparatus for performing plating including a schematic illustration of an indexing device for moving a plurality of articles through the coating system indexing and reindexing the articles with respect to the electrochemical cells of the apparatus;

FIG. 2 is a perspective view of an electrochemical cell for performing process steps involving passing current through the cell in a method of electroplating an article, such as a tubing;

FIG. 3 is a cross-sectional view of the electrochemical cell of FIG. 2 taken along the lines 3—3 of FIG. 2 and partially broken away for clarity;

FIG. 4 is a perspective view of a guide member of the electrochemical cell shown in FIG. 3;

FIG. 5 is a view from above of a rinsing cell for performing a cleaning process step which includes flowing a predetermined amount of rinse fluid to the cell;

FIG. 6 is a cross-sectional view of the rinsing cell of FIG. 5 taken along the line 6—6 of FIG. 5 which is partially broken away for clarity, the rinsing cell being shown in an operative condition during rinsing of an article, such as a tubing.

DETAILED DESCRIPTION OF THE INVENTION

FIG. 1 is a perspective view of an apparatus 10 for performing electrochemical processes, such as a plating apparatus for applying nickel plate to tubing. FIG. 1 includes a schematic illustration on an indexing device 12 for moving a plurality of articles through the plating system. The indexing device includes one or more carriers, as represented by the horizontally extending carrier 14. Each carrier has a plurality of openings 16 which adapts the indexing device to receive a plurality of articles, such as a plurality of tubings 18. Each tubing has an outer wall 19 and an inner wall 20. The indexing device includes a support 22 which might engage a belt which carries the indexing device and provides for continuous movement of indexing devices through the apparatus.

As shown in FIG. 1, the plating apparatus 10 includes a plurality of cells for treating the articles, such as electrochemical cells and rinsing cells. The electrochemical cells for electrochemically treating the tubing are represented by the cells 24, 26, 28, 32. These cells are formed in the same manner and are each similar in design to the representative cell 32. Cell 32 is shown in FIG. 2 and FIG. 3 and is discussed below in more detail. Each electrochemical cell 24, 26, 28, 32 is in flow communication with means 34 for supplying electrochemical fluid, such as electrolytic fluid. Electrolytic fluid is commonly referred to as an "electrolyte". The means for supplying electrochemical fluid has a reservoir 36, a pump 38, a filter 42 for the electrolyte, and, as shown in FIG. 3, both a supply conduit 44 and a return conduit 46 for supplying the electrolyte and removing the electrolyte from the interior of the cell. In the embodiment shown, a portion of the supply conduit 44 and return conduit 46 are part of electrochemical cell and extend through the interior of the electrochemical cell.

The plating apparatus 10 includes a plurality of rinsing cells, as represented by the rinsing cells 48, 50, 52, for cleaning the electrochemical fluid from the tubing as required. The rinsing cell is shown in FIG. 5 and FIG. 6 and is discussed in more detail below. Each rinsing cell is in flow communication with means 54 for supplying a rinse fluid, such as deionized water. The means includes a reservoir 56, a pump 58, a supply conduit 62 and, as shown in FIG. 5, a return conduit 64 for supplying and removing rinse fluid. In the embodiment shown in FIG. 6, a portion of the supply conduit 62 and return conduit 64 are part of the rinsing cell and extend through the interior of the rinsing cell. The return conduit is in flow communication with the reservoir 56 or might be in flow communication with a sump (not shown) for collecting the fluid for later disposal.

FIG. 2 is a perspective view of one of the electrochemical cells, such as plating cell 32. The electrochemical cell has an axis A and has an outer housing 66 having a base 68. The outer housing includes a wall 70 which extends circumferentially about the cell. The cell has a cap 72 having an opening 74 for receiving the tubing.

FIG. 3 is a cross-sectional view of the cell 32 taken along the line 3—3 of FIG. 2. The cross-sectional view is partially

broken away for clarity. The electrochemical cell has a first electrode, as represented by the carbon-platinum electrode **76**. The first electrode is commonly referred to as a carbon electrode or housing electrode. The first electrode has at least a portion, such as a wall **78**, which extends circumferentially about the cell to form an electrode chamber **80** for receiving electrolyte. The electrode chamber has a first region, such as a bottom **82** of the electrode chamber; and a second region, such as the top **84** of the electrode chamber.

The electrode chamber **80** adapts the electrochemical cell to receive electrolyte and to receive a second electrode **86** of the electrochemical cell. The second electrode is the article being processed, such as the tubing **18** which has the outer wall **19** and the inner wall **20**.

The second electrode **86** (or tubing **18**) is disposed in the electrode chamber **80** under said operative condition. The second electrode is spaced radially from the first electrode leaving a gap **G** therebetween. The gap **G** extends about the perimeter of the electrochemical cell and forms electrolyte passage **88**. The gap **G** is circumferentially continuous but might be interrupted in alternate embodiments. The tubing has a hydraulic diameter **D**, which is four times the cross-sectional area, bounded by the perimeter of the tubing and divided by the perimeter of the tubing. In the embodiment shown, the hydraulic diameter was about four (0.4) tenths of an inch or about one (1) centimeter. The gap **G** was about two (0.2) tenths of an inch or about one-half of one centimeter (0.5 cm). Thus, the hydraulic diameter **D** is about twice the gap **G**.

The electrical circuit includes a power supply (not shown) for providing direct current to apparatus **10**. Depending on the operation being performed, the tubing may be either the anode or the cathode of the electrical circuit that causes the electrochemical reaction. If the tubing is the anode, current flows away from the tubing. If the tubing is the cathode, current flows toward the tubing. In the embodiment shown, the tubing is the cathode.

FIG. 4 is a perspective view of a guide member **90** of the electrochemical cell. As shown in FIG. 3 and FIG. 4, the guide member is disposed in the electrode chamber **80** for guiding the tubing **18** as it enters the chamber. The guide member has a seat **92** having a tapered surface **94** facing outwardly in the axial direction. A pin **96** extends axially from the seat and is disposed in the electrode chamber **80**. The pin adapts the guide member to position the tubing in the chamber as it enters and is disposed in the cell to avoid contact between the tubing and the electrode. The seat contacts the tubing at a predetermined location to ensure that the correct length of tubing has entered the chamber. A proximity sensor **98** confirms that the tubing is in its correct location.

As discussed above with FIG. 3, the annular passage **88** for electrolyte is bounded outwardly by the housing electrode **76** and inwardly by the pin **96**; and after insertion of the tubing, inwardly by the tubing **18**. The electrolyte passage has a first or supply opening, as represented by the annular supply opening **100**. The electrolyte passage has a second or exhaust opening, as represented by the annular exhaust opening **102**. The supply opening extends in flow communication with a source of electrolyte, as represented by the supply conduit **44**. The supply conduit has a diffusion region **103** upstream of the annular supply opening **100**. A swirler, as represented by the swirler **104**, is disposed between the diffusion region and the supply opening of the electrolyte passage. The diffusion region slows the flow to reduce turbulence as the flow passes through the swirler and

increases the static pressure of the flow prior to entering the swirler. Disposing the swirler between the diffusion region and the supply opening further spaces the sudden expansion of the diffusion region from the electrode chamber to ensure that unacceptable turbulence is not introduced into the flow.

The swirler **104** is attached to the seat **92** of the guide member **90** for centering the guide member in the electrode chamber **80**. The swirler has a plurality of canted holes **106** or openings. The holes are disposed about an axis **Ac** and are at an angle with respect to a plane containing the axis **A**. The holes impart a lateral or circumferential component of velocity to the electrolyte as the electrolyte flows in a generally axial direction through the swirler and thence through the electrolyte passage adjacent the tubing. The velocity is small enough to avoid cavitation and large enough to avoid other discontinuities in electrolyte concentration which might form because of the passage of the electrical current through the electrolyte. In the embodiment shown, the swirler is disposed between the electrode and adjacent structure of the electrochemical cell. In an alternate embodiment, for example, the swirler might be disposed entirely within the electrode chamber or disposed upstream of the electrode to such an extent that it is spaced axially from the electrode.

The return conduit **46** includes a collection chamber **108**. The collection chamber is an annular chamber bounded by the wall **70** of the outer housing **66**. The wall **70** extends circumferentially about and is radially spaced from the housing electrode **76**. The collection chamber receives electrolyte exhausted from the electrolyte passage through the exhaust opening **102**.

The cap **72** has return holes **110**. These holes provide a passage for returning electrolyte to the cell **32** as the tubing is removed from the cell and drops of electrolyte fall from the tubing. The cap includes a plate **112** which is spaced axially from the housing electrode **76** leaving an overflow passage **114** therebetween. The overflow passage places the annular electrolyte passage **88** in flow communication with the collection chamber **108**.

The opening **74** also constrains the tubing against radial movement as the tubing is moved axially into the electrochemical cell. Thus, the opening aligns the tubing with the pin **96** and also blocks the tubing from contacting the housing electrode **76**. In alternate embodiments, the opening might have a conical shape so that the opening tapers in the axial inward direction to accommodate a degree of misalignment between the opening and the tube. In the present embodiment, either the opening **74** or the guide member **90** provides means for guiding the tubing, as the tubing is disposed in electrochemical cell. Thus, both the guide member **90** and the opening **74** in the cap cooperate to locate and constrain movement of the tubing **18** as it enters the electrochemical cell to block contact between the tubing and the cell which might otherwise cause a short-circuit.

As mentioned about the embodiment shown, the pin **96** is a sufficient length such that the opening **74** centers the tubing **18** on the guide member **90**. Accordingly, the opening is not needed to constrain errant movement of the tubing which is already constrained by the guide member. In an alternate embodiment, the guide member might be eliminated by having an opening of sufficient axial length that the tubing is centered in the electrode chamber and engages a stop which corresponds to tapered surface **94** of the guide member.

During operation of the electrochemical cell **32**, electrolyte is supplied to the bottom of the cell through the supply

conduit **44**. The electrolyte flows upwardly into the electrode chamber **80** with a slight circumferential velocity. This circumferential velocity does not create turbulence but does block the formation of regions of varying electrolyte concentration which might be induced by the flow of current through the electrolyte.

Flowing the electrolyte fluid vertically to the overflow passage enables a reasonably uniform removal of fluid from the circumference of the electrolyte passage. Flowing electrolyte fluid vertically and in a downward direction and removing the fluid through a single drain hole might introduce variations in concentration of the electrolyte which might adversely affect plating activity. In addition, the guide member is centrally disposed in the electrode chamber inside the article to be coated. As a result, the guide member does not interfere with the passage of current from the cathode to the anode by introducing a nonconductive material into the electrical field.

An advantage of the electrochemical cell is that small solution volumes are usable for processing a single tubing. This decreases environmental impact as compared to large plating tanks, producing smaller amounts of waste compared to large batch processing. The small size enables the cells to be located in a local area with acceptable lead-time and just in time production for producing parts. In addition, the quality of the plating system enabled maintaining tolerances that were smaller than a thousandth of an inch.

FIG. **5** is a view from above of the rinsing cell **52** with a tubing **18** installed in the rinsing cell. The rinsing cell is disposed about an axis of symmetry R. FIG. **6** is a cross-sectional view of the rinsing cell **52** taken along the line **6—6** of FIG. **5** with a portion of the rinsing cell partially in full and partially broken away for clarity. The rinsing cell has a wall **122** which extends circumferentially about the axis R to form a rinse chamber **124**. The rinse chamber is bounded by an axially facing surface **126** and has a lower region or bottom **128**. The supply conduit **62** includes a supply passage **130** for rinse fluid which is disposed in the cell and is in flow communication with the means **54** for supplying rinse fluid to the cell.

A guide member **132** is disposed in the rinse chamber **124** and extends axially in the chamber. In the embodiment shown, the guide member extends in the vertical direction. The guide member has a base **134** and a pin **136**. An axially extending passage **138** for rinse fluid extends through the base and the pin. The guide member has a plurality of impingement holes **140**. The impingement holes place the passage **138** of the pin in flow communication with the interior of the rinse chamber. In the operative condition, the tubing **18** is disposed about the guide member **132** and is spaced from the pin leaving an annular drain passage **142** therebetween. The tubing is disposed about the guide member such that impingement flow strikes the inside or inner wall **20** of the tubing. The impingement holes may be angled toward the bottom **128** of the rinse chamber to impart an axial component of velocity to the flow. The axial component of velocity decreases the effect that splash back from the impingement stream has on the flow. The vertical orientation of the drain passage causes gravity to urge the rinse fluid to flow downwardly along the inside of the tubing.

The base **134** of the guide member has a plurality of slots **144**. The slots are spaced axially from the bottom of the rinse chamber. The slots are spaced circumferentially about the base leaving a seating surface **146** therebetween. The seating surface diverges axially to a diameter which is larger than

the diameter of the inner wall of the tubing to locate the tubing in the axial (vertical) direction. The seating surface adapts the base member to engage the tubing at a line of contact. The line of contact is interrupted by the slots to permit drainage of the rinse fluid to the bottom of the chamber.

The rinsing cell has a cap **148**. The cap has a hole **150** which adapts the cell to receive the tubing **18**. The supply conduit **62** for rinse fluid includes other passages on the interior of the rinsing cell. For example, the cap has a plurality of radially directed impingement passages **152** in flow communication with the rinse chamber **124**. The passages are directed toward the bottom of the rinse chamber to impart an axial component of velocity to the rinse flow. As with the interior of the tubing, the axial component of velocity decreases the effect that splash-back of rinse fluid impinging on the tubing has on flow to the bottom of the chamber. The cell includes a circumferentially extending plenum **154** which is in flow communication with the radially directed impingement passages and is, in turn, in flow communication through axial passages **156** and **157** with the supply passage **130** in the cell. The means **54** for supplying rinse fluid includes the supply conduit **62** and the return conduit **64** which are each in flow communication with the rinse fluid reservoir **56**. As shown, the return conduit is spaced from the bottom of the rinse chamber. Alternatively, the return conduit may be in flow communication with the bottom most portion of the rinse chamber to completely drain rinse fluid from the rinse chamber.

An advantage of the rinsing cell is the controlled dispensing of rinse fluid, such as water, under pressure which produces a small amount of waste and the lower costs associated with waste disposal. In addition, automating the rinsing process minimizes operator fatigue and eliminates continuous movements by the operator of a rinsing device which might lead to repetitive motion injuries were one person to rinse a large volume of tubes moving through the assembly line on a daily basis.

During operation of the apparatus **10**, the apparatus may be used by hand by eliminating the tubing carrier **14** or may use the tubing carrier with hand operation automatically with sensors. For example, the electrochemical cell and the rinsing cell might each have a proximity sensor, such as the inductive sensors **98**, **158** which sense the presence of the tubing in the correct position in the cell. The sensor might rely on conductivity or inductivity of the tubing to trigger the sensor. In one embodiment, an inductive sensor was used which fits into the side of the housing. The inductive sensor triggers a relay timer. For the rinse system, the relay timer used is specifically set to a single shot mode for supplying the rinse fluid. Upon receiving a signal from the sensor, the timer closes a function circuit to provide a given duration of flow. Removing the tubing resets the system such that the timer can again be reactivated to provide rinse flow. The function circuit could be any conventional circuit such as, for example, one that is solenoid operated with a close center fluid control valve. The valve will allow flow of water to the rinse system when the tube is present and sensed by the inductive sensor.

During operation of the plating system **10**, the first electrochemical cell **24** provides electrochemical cleaning to the tubing by flowing current toward the tubing, that is, the housing electrode is the anode and the tubing is the cathode. In one example involving the use of steel tubing and nickel plate on the tubing, the electroplating fluid was a sodium hydroxide base of about one (1) to five (5) percent sodium hydroxide by weight with the remainder as water. One

satisfactory electrolyte is available from Sifco Industries, Cleveland, Ohio as Sifco Selectron Solution Code SCM 4100 electrolyte solution. Following a rinse cycle with water in the rinsing cell **48**, the tubing is disposed in the second electrochemical cell **26** for etching. One satisfactory electrolyte is Sifco Selectron Solution Code SCM 4250, Activator No. 4 solution which is about five (5) to ten (10) percent by weight hydrochloric acid (HCl) with the balance water. Etching is provided by flowing current away from the tubing, that is, the housing electrode **76** of cell **26** becomes the cathode and the tubing becomes the anode. Following a second rinse cycle in rinsing cell **50**, the tubing is disposed in the third electrochemical cell **28** for activating the surface of the tubing for plating. Activating is provided by flowing current toward the tubing, that is, the housing electrode becomes the anode and the tubing becomes the cathode. One satisfactory electrolyte is Sifco Selectron Solution Code SCM 4200, Activator No. 1 which is about five (5) to ten (10) percent sulfuric acid by weight; about seven (7) to thirteen (13) percent ammonium sulfate by weight with the remainder water. Finally, the tubing is removed from the activating electrochemical cell and moved directly to the plating cell **32** without rinsing. One satisfactory plating electrolyte is Sifco Selectron Solution Nickel Code SPS 5600. It is important that the activating solution not dry on the tubing before entering the plating cell.

During operation of the plating system **10**, the method may be used automatically to treat a plurality of tubings **18** with electrochemical processes. The steps include forming an array of dedicated cells, that is, dedicated to performing a single process. The array of dedicated cells might be an array of electrochemical cells **24**, **26**, **28**, **32** or an array of electrochemical cells **24**, **26**, **28**, **32** and an array of rinsing cells **48**, **50**, **52** as shown. The array of cells is disposed with the cells in proximity one to the other such that their proximity enables relative movement of each tubing from one cell to the next, whether the next cell is an electrochemical cell or a rinsing cell.

In the embodiment shown, the tubings **18** are indexed to the dedicated cells **24**, **48**, **26**, **50**, **28**, **32**, **52** such that each tubing is aligned with the dedicated cell which is associated with the next process to be performed on the tubing. After the process is performed on the tubing, the array of tubings is reindexed such that each tubing moves to the next cell. A new tubing is added to the array and the finished tubing at the last cell is removed. As mentioned earlier, the electrolyte is flowed at a relatively steady rate in electrochemical cells and through the electrolyte passage **88** and from the cell. In rinsing cells, a predetermined amount of rinse fluid is supplied to the cell for each tubing that is processed. In one application, the amount of rinse fluid for each tubing was less than one ounce of fluid. The fluid is flowed from either type of cell during the process. In the rinsing cell, a small amount of rinse fluid may remain below the tubing in the bottom of the cell.

A data processing device **162**, such as a computer, may be used with the array of cells **24**, **48**, **26**, **50**, **28**, **32**, **52** by being in signal communication with the cells through electrical conduits **164**. This provides a data processing capability to the plating system **10**. The data processing device may be programmed to calculate the duration of time that each tubing spends at each dedicated cell which necessarily determines the longest duration of time at each cell. The device causes each tubing to remain at its dedicated cell until the tubing requiring the longest processing time has completed its process. The data processing device turns off the process at the other cells as each process reaches its con-

clusion. Thus, the process may be automated with associated reductions in cost and materials.

Although the invention has been shown and described with respect to detailed embodiments thereof, it should be understood by those of ordinary skill that various changes in form and in detail thereof may be made without departing from the spirit and scope of the claimed invention.

We claim:

1. An electrochemical cell having an operative condition for electrochemically treating an article, which comprises:

- a first electrode which is integrally attached to the electrochemical cell and which has an electrode chamber for receiving an electrolyte and for receiving a second electrode, the first electrode having a portion of the electrode which extends about the electrode chamber;
- a second electrode which is the article being treated and which is removably disposed in the electrode chamber at a location inwardly of said portion of the first electrode under said operative condition;
- a first conduit for supplying electrolyte to the electrode chamber under said operative condition;
- a second conduit for removing electrolyte from the electrode chamber under said operative conditions;

wherein the electrochemical cell has an opening for removably receiving the article which forms the second electrode and through which the electrode extends under said normal operative condition; and wherein the first electrode extends about the second electrode leaving a gap therebetween which is adapted to provide an electrolyte passage under said operative condition, the electrolyte passage having a first opening formed by the gap which extends about the second electrode and which places the electrolyte passage in flow communication with the first conduit for supplying electrolyte to the electrolyte passage under said operative condition and a second opening formed by the gap which is spaced axially from the first opening, the second opening extending about the second electrode which places the electrolyte passage in flow communication with the second conduit for removing electrolyte from the electrolyte passage under said operative condition.

2. The electrochemical cell of claim **1** wherein the electrolyte is flowed in a first direction toward the electrolyte passage through the supply conduit to the electrolyte passage, wherein the electrochemical cell has a swirler which is in flow communication with the first opening for imparting a lateral component of velocity to the electrolyte under said operative condition as the electrolyte is flowed in the first direction.

3. The electrochemical cell of claim **2** wherein the swirler has at least two holes canted with respect to the first direction of the electrolyte flow under said operative condition.

4. The electrochemical cell of claim **2** wherein the supply conduit includes a diffusion region upstream of the swirler.

5. The electrochemical cell of claim **1** wherein the electrochemical cell includes means for imparting swirl to the electrolyte flow under said operative condition.

6. The electrochemical cell of claim **1** wherein the gap is an annular gap.

7. An electrochemical cell having an operative condition for electrochemically treating an article, which comprises:

- a first conduit for supplying electrolyte under said operative condition;
- a second conduit for removing electrolyte under said operative condition;
- a first electrode which extends circumferentially about an axis A to form an electrode chamber;

11

a second electrode which extends about the axis A, which is the article and which is removably disposed in the electrode chamber;

wherein the electrochemical cell has an opening for removably receiving the article which forms the second electrode; and, wherein the first electrode extends about the second electrode leaving a gap G therebetween which is adapted to form an annular electrolyte passage, the electrolyte passage having a first opening formed by the gap which is annular, which is circumferentially continuous and which extends about the second electrode and which places the electrolyte passage in flow communication with the first conduit for supplying electrolyte to the electrolyte passage under said operative condition and a second opening formed by the gap which is spaced axially from the first opening, the second opening extending about the second electrode which places the electrolyte passage in flow communication with the second conduit for removing electrolyte from the electrolyte passage under said operative condition.

8. The electrochemical cell of claim 7 wherein a guide member is disposed in the electrode chamber and extends axially in the chamber and wherein the second electrode is removably disposed about the guide member and contacts the guide member.

9. The electrochemical cell of claim 7 wherein a swirler is disposed adjacent the electrode chamber and in the first conduit for imparting a circumferential component of velocity to the electrolyte under said operative condition.

10. The electrochemical cell of claim 9 wherein a guide member is disposed in the electrode chamber and extends axially in the chamber, wherein the second electrode is removably disposed about the guide member and contacts the guide member and wherein the guide member is attached to the swirler.

11. The electrochemical cell of claim 7 wherein the electrolyte passage extends in a vertical direction, wherein the electrochemical cell has a wall which extends circumferentially about the first electrode and is spaced radially from the first electrode leaving an annular collection chamber therebetween and wherein the second opening is in flow communication with the annular collection chamber such that electrolyte flow under said operative condition overflows from the second opening between the first electrode and the second electrode and into the collection chamber.

12. The electrochemical cell of claim 7 wherein the supply conduit includes a diffusion region upstream of the swirler.

12

13. The electrochemical cell of claim 7 wherein the article has a hydraulic diameter D and wherein the gap G is less than the hydraulic diameter D.

14. The electrochemical cell of claim 13 wherein the hydraulic diameter D is less than one-half of an inch ($D < 0.5$ inches).

15. A method of electrochemically treating an article by passing an electrical current through an electrolyte, comprising:

disposing a first electrode having an axis A about the article by relative movement along the axis between the first electrode and the article to form at least a portion of an electrode chamber for receiving an electrolyte and into which the article extends from the exterior of the first electrode;

disposing electrolyte in the chamber;

placing the article in electrical communication with the first electrode such that the article forms the second electrode; passing electrical current between the electrodes to electrochemically affect a surface of the article.

16. The method of electrochemically treating an article of claim 15 includes the step of flowing additional electrolyte into the electrode chamber and displacing electrolyte from the electrode chamber during the step of passing an electrical current through the electrolyte.

17. The method of electrochemically treating an article of claim 15 wherein the electrode chamber has a bottom and a top and wherein the step of flowing additional electrolyte into the electrode chamber includes flowing electrolyte into the bottom of the electrode chamber and overflowing electrolyte from the top of the electrode chamber.

18. The method of electrochemically treating an article of claim 15 wherein the electrode chamber is disposed about an axis A, the step of disposing the article in the chamber includes disposing the article about the axis A leaving an annular passage for electrolyte therebetween; and wherein the step of flowing electrolyte through the electrode chamber includes flowing electrolyte upwardly with a circumferentially directed component of velocity about the article to block the formation of current induced variations in the concentration of the electrolyte.

* * * * *