



US006543225B2

(12) **United States Patent**  
**Scuderi**

(10) **Patent No.:** **US 6,543,225 B2**  
(45) **Date of Patent:** **Apr. 8, 2003**

(54) **SPLIT FOUR STROKE CYCLE INTERNAL COMBUSTION ENGINE**

(75) Inventor: **Carmelo J. Scuderi**, Springfield, MA (US)

(73) Assignee: **Scuderi Group LLC**, Springfield, MA (US)

(\* ) Notice: Subject to any disclaimer, the term of this patent is extended or adjusted under 35 U.S.C. 154(b) by 0 days.

(21) Appl. No.: **09/909,594**

(22) Filed: **Jul. 20, 2001**

(65) **Prior Publication Data**

US 2003/0014971 A1 Jan. 23, 2003

(51) **Int. Cl.**<sup>7</sup> ..... **F02G 1/00**; F02B 75/24

(52) **U.S. Cl.** ..... **60/597**; 123/53.1; 123/53.5

(58) **Field of Search** ..... 60/597; 123/52.2, 123/52.3, 53.1, 53.3, 53.5, 55.4, 55.5

(56) **References Cited**

**U.S. PATENT DOCUMENTS**

810,347 A	1/1906	Porter et al.	
848,029 A	3/1907	Haselwander	
939,376 A	11/1909	Appleton	
1,111,841 A	9/1914	Koenig	
1,248,250 A	11/1917	Bohler	
1,301,141 A	4/1919	Leadbetter et al.	
1,392,359 A	10/1921	Rudavist	
1,790,198 A	* 1/1931	Cizek	123/53.1 X
1,856,048 A	4/1932	Ahrens	

(List continued on next page.)

**FOREIGN PATENT DOCUMENTS**

DE	2515271	10/1976
DE	2628155	1/1978
FR	24163344	8/1979
GB	299.602	11/1928
GB	383866	11/1932
GB	721.025	12/1954
IT	505576	12/1954

JP	51-39306	4/1976
JP	51-91416	8/1976
JP	54-89108	7/1979
JP	56-8815	2/1981
JP	56-99018	5/1981
JP	56-145641	11/1981
JP	57-181923	11/1982
JP	60-143116	9/1985
JP	60-256642	12/1985
JP	62-126523	8/1987
JP	63-124830	5/1988
JP	5-502707	5/1993
JP	5-156954	6/1993
JP	6-159836	6/1994
JP	8-503043	4/1996

(List continued on next page.)

**OTHER PUBLICATIONS**

www.tiscali.co.za/moto/moto\_center\_011011.403978.html, pp. 1-2, Oct. 17, 2001.

JSAE Convention Proceedings, Date 1996, Issue 966, pp. 129-132.

*Primary Examiner*—Hoang Nguyen

(74) *Attorney, Agent, or Firm*—McCormick, Paulding & Huber LLP; Stephen P. Scuderi

(57) **ABSTRACT**

A four stroke cycle internal combustion engine including a crankshaft, rotating about a crankshaft axis of the engine. A power piston is slidably received within a first cylinder and operatively connected to the crankshaft such that the power piston reciprocates through a power stroke and an exhaust stroke of a four stroke cycle during a single rotation of the crankshaft. A compression piston is slidably received within a second cylinder and operatively connected to the crankshaft such that the compression piston reciprocates through an intake stroke and a compression stroke of the same four stroke cycle during the same rotation of the crankshaft. A gas passage interconnects the first and second cylinders. The gas passage includes an inlet valve and an outlet valve defining a pressure chamber therebetween.

**50 Claims, 7 Drawing Sheets**

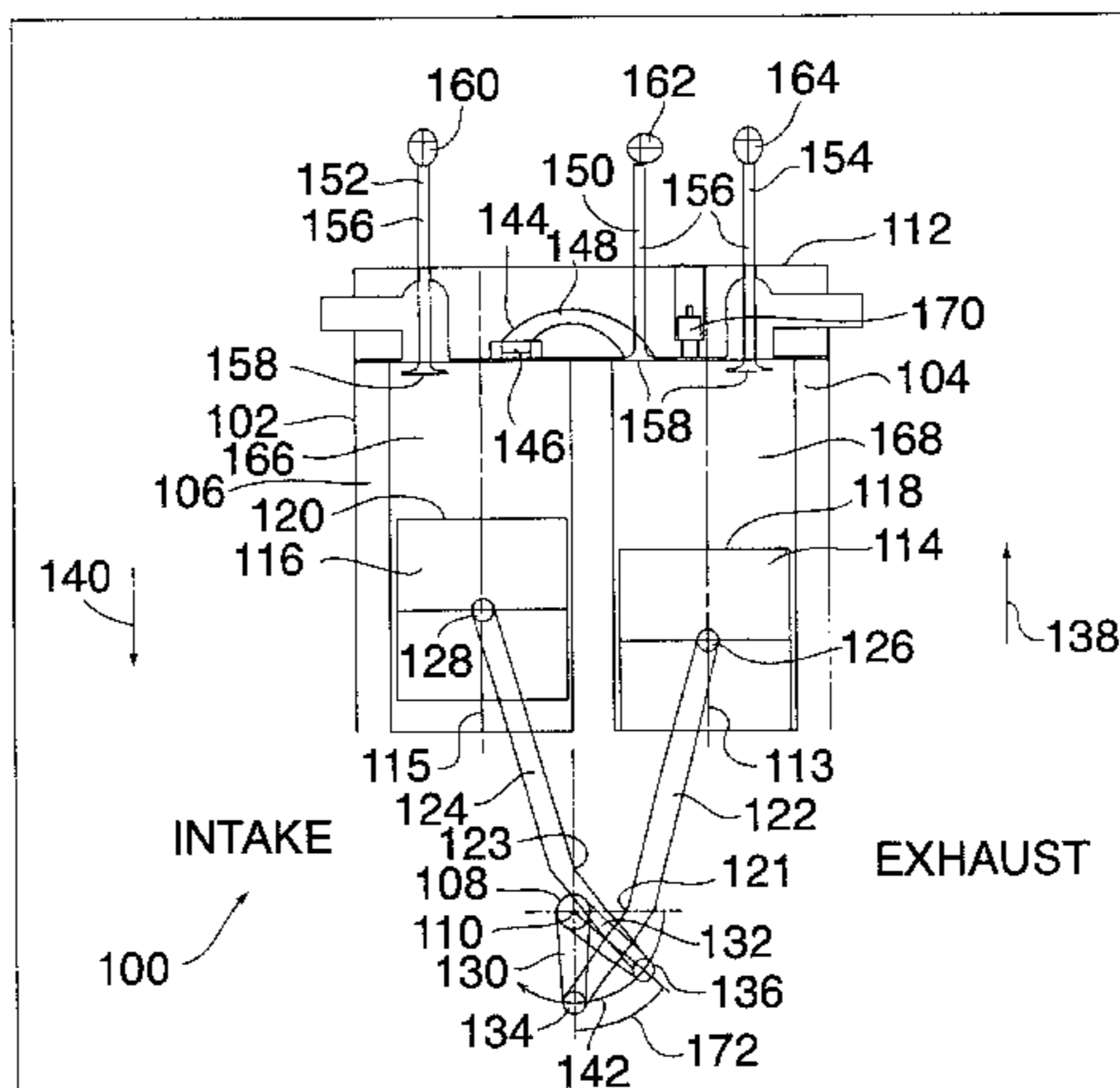

U.S. PATENT DOCUMENTS

1,969,815 A 8/1934 Mever  
 2,154,856 A 4/1937 Mallory  
 2,091,410 A 8/1937 Mallory  
 2,091,411 A 8/1937 Mallory  
 2,091,412 A 8/1937 Mallory  
 2,091,413 A 8/1937 Mallory  
 2,269,948 A 1/1942 Mallory  
 2,280,712 A 4/1942 Mallory  
 2,957,455 A 10/1960 Bouvv  
 2,974,541 A 3/1961 Dolza  
 3,774,581 A 11/1973 Lundy  
 3,895,614 A 7/1975 Bailey  
 4,450,754 A 5/1984 Liliequist  
 4,628,876 A 12/1986 Fuiikawa et al.  
 4,805,571 A 2/1989 Humphrey  
 4,945,866 A \* 8/1990 Chabot, Jr. .... 123/54 R  
 4,955,328 A 9/1990 Sobotowski  
 5,146,884 A 9/1992 Merkel  
 5,546,897 A \* 8/1996 Brackett ..... 123/70 R

5,623,894 A 4/1997 Clarke  
 5,711,267 A 1/1998 Williams  
 5,799,636 A 9/1998 Fish  
 5,950,579 A 9/1999 Ott  
 5,992,356 A 11/1999 Howell-Smith  
 6,058,901 A 5/2000 Lee  
 6,202,416 B1 3/2001 Gray, Jr.  
 6,230,671 B1 5/2001 Achterberg

FOREIGN PATENT DOCUMENTS

JP 8-158887 6/1996  
 JP 8-232675 9/1996  
 JP 8-261004 10/1996  
 JP 2000-508403 7/2000  
 JP 2001-12250 1/2001  
 JP 2001-207801 8/2001  
 JP 2002-506949 3/2002  
 SU 1551880 A1 6/1988  
 WO WO 01/16470 A1 3/2001

\* cited by examiner

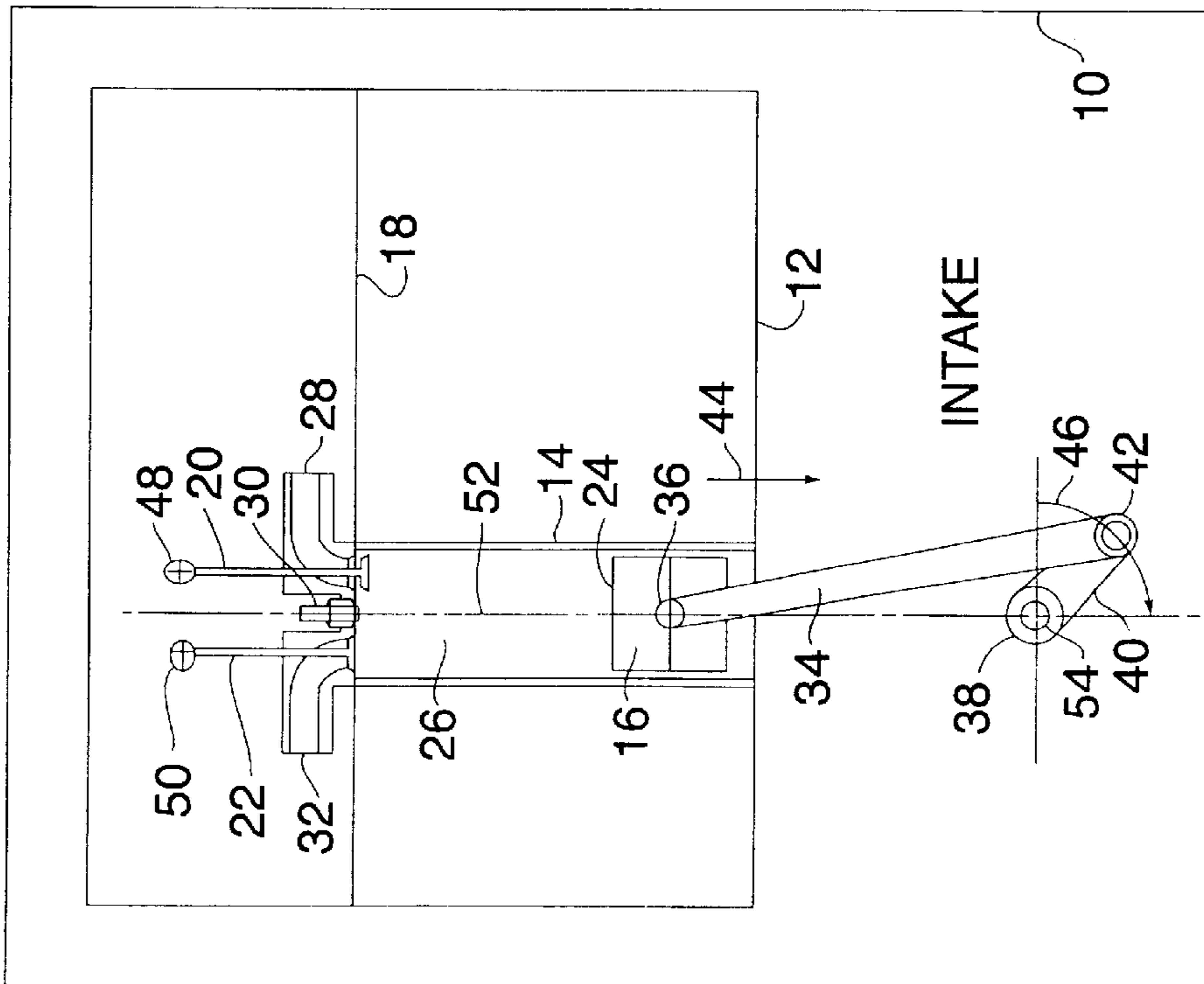
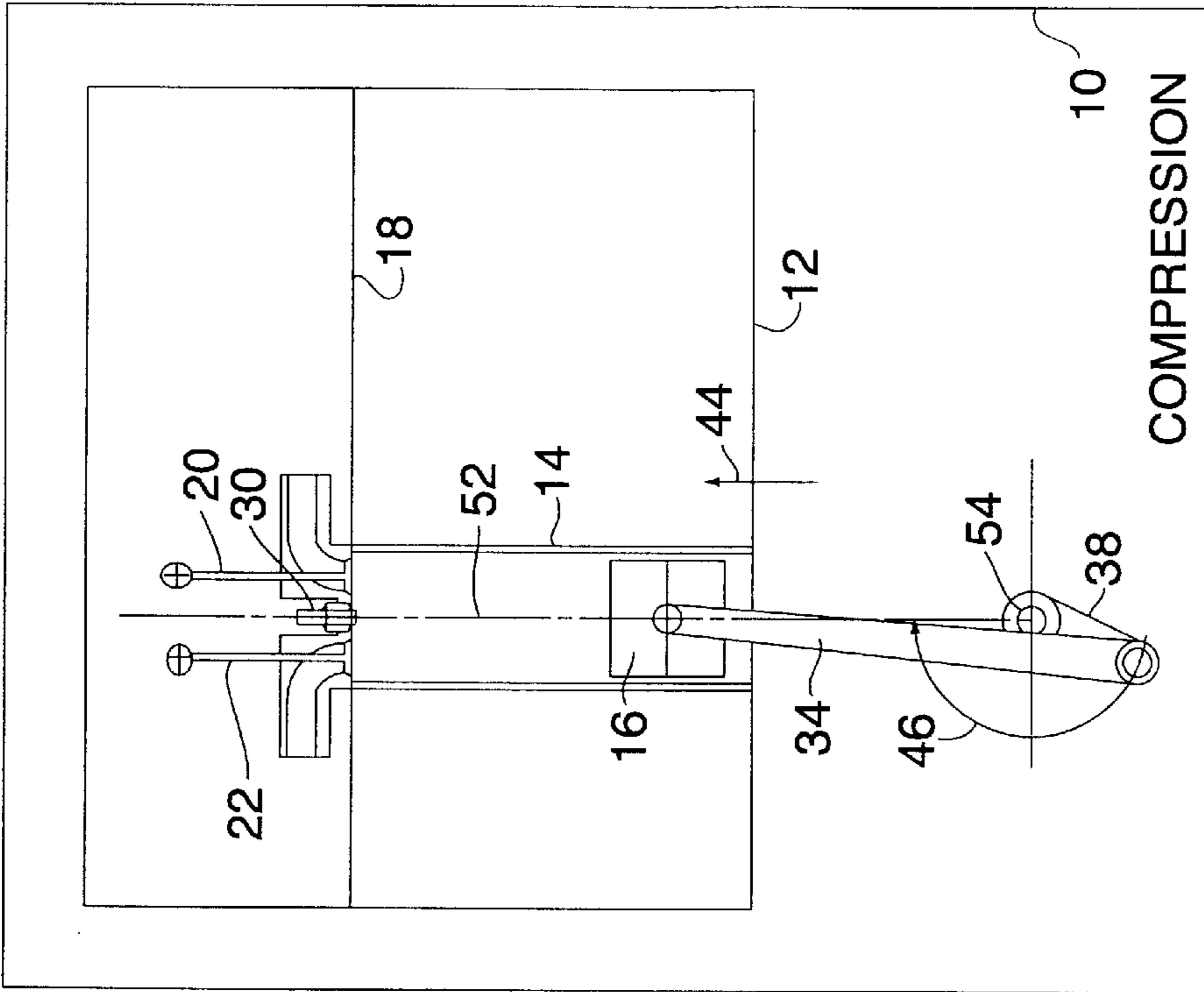

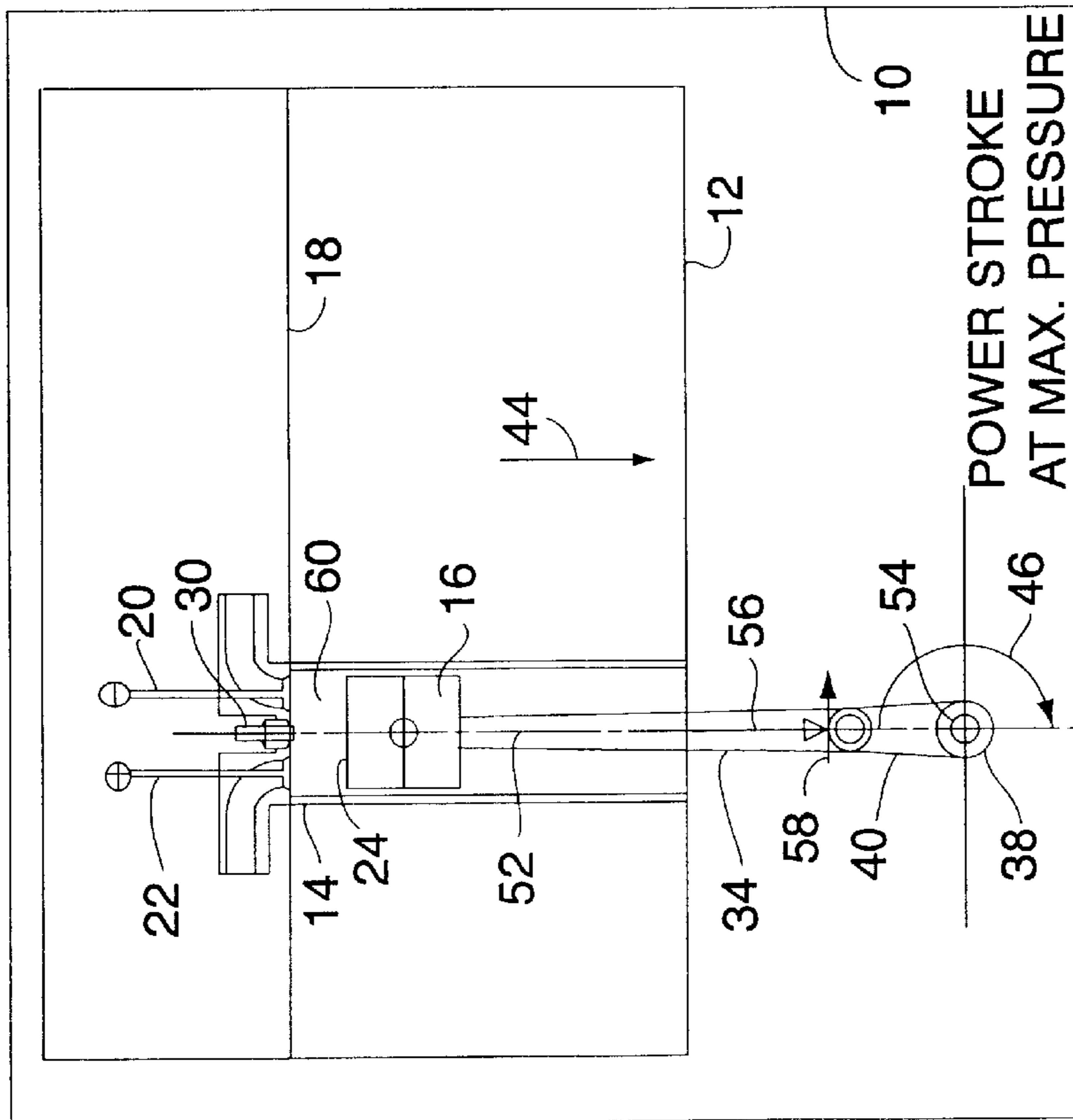
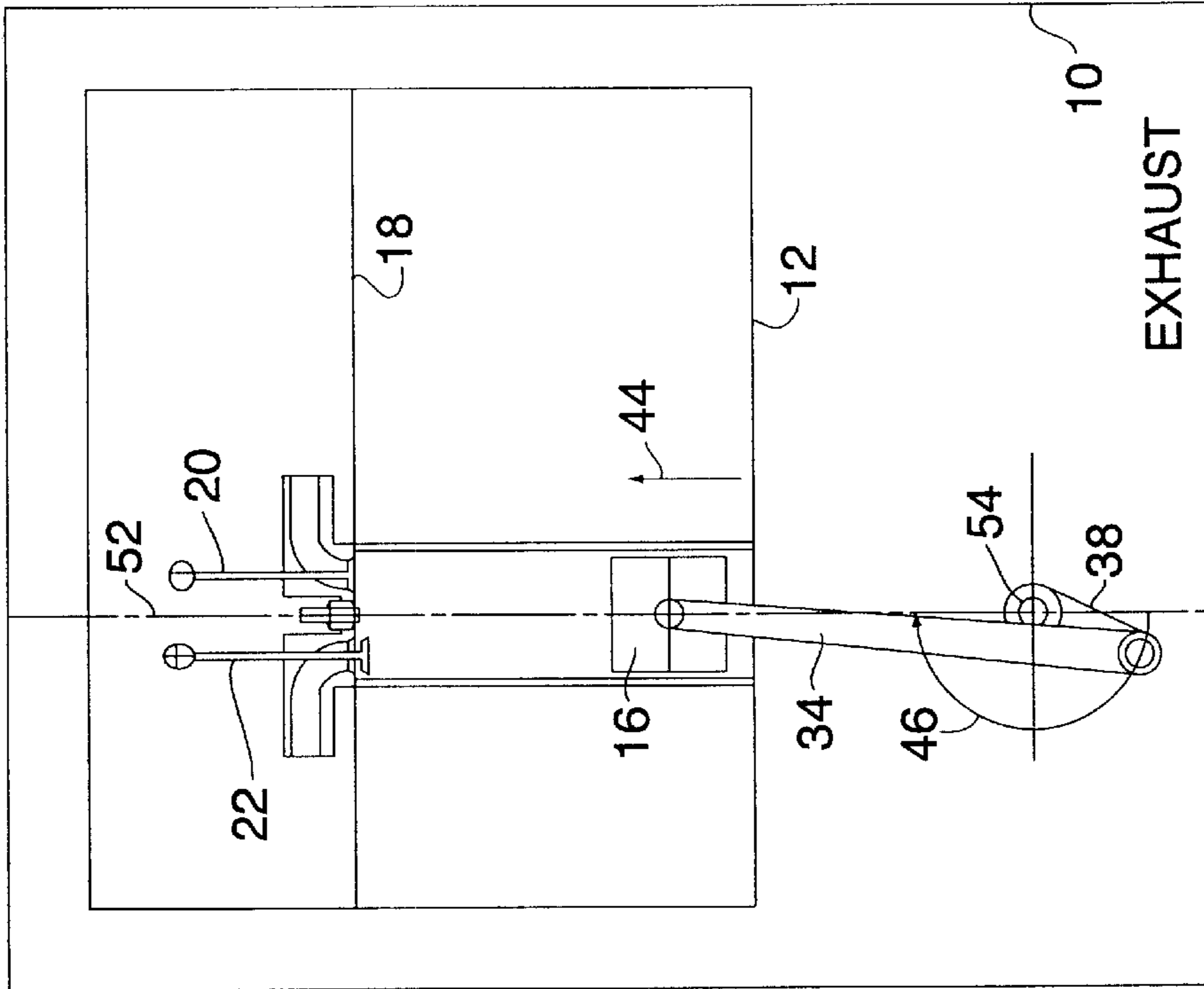

FIG. 3  
PRIOR ART

FIG. 4  
PRIOR ART

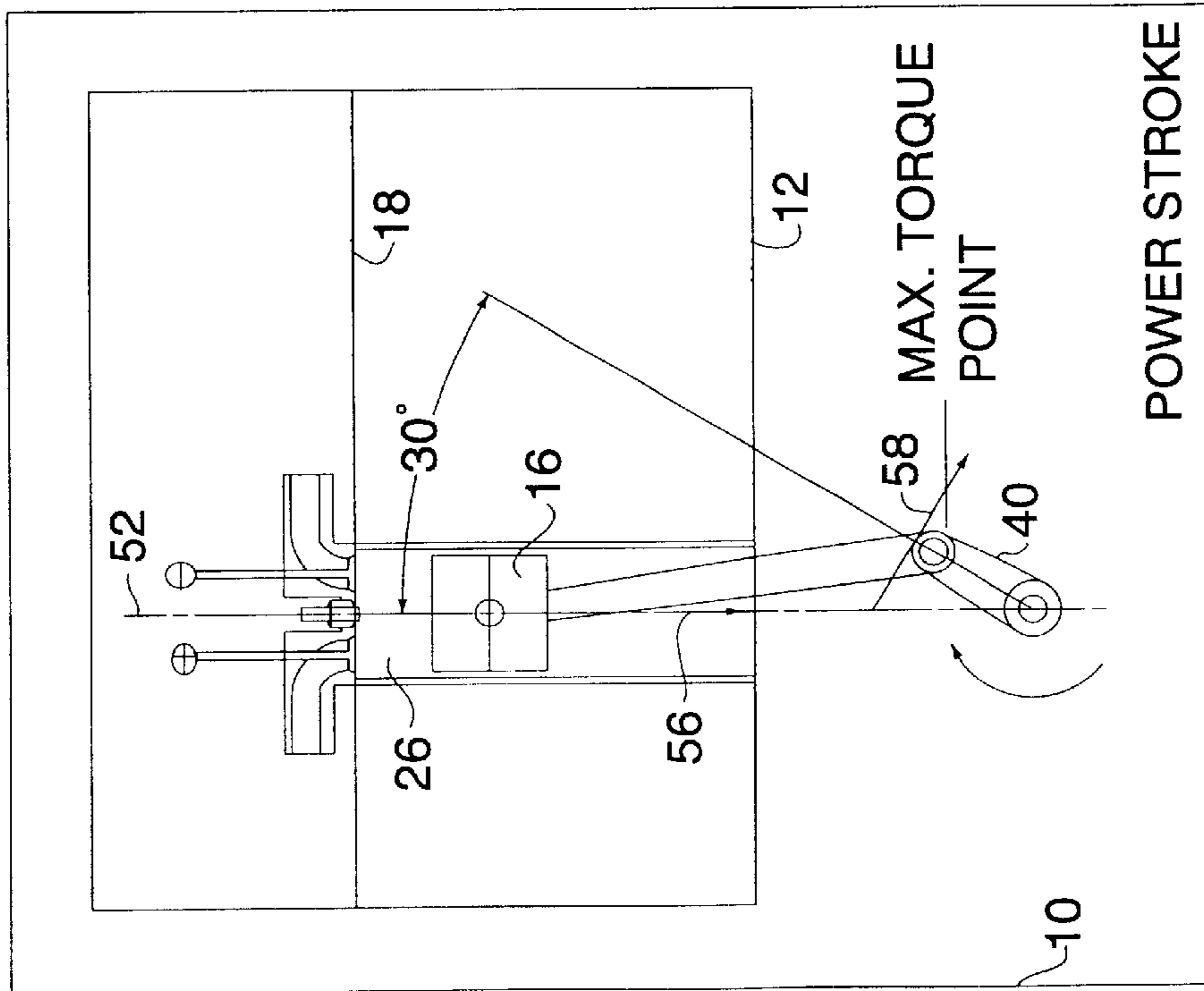

FIG. 5  
PRIOR ART

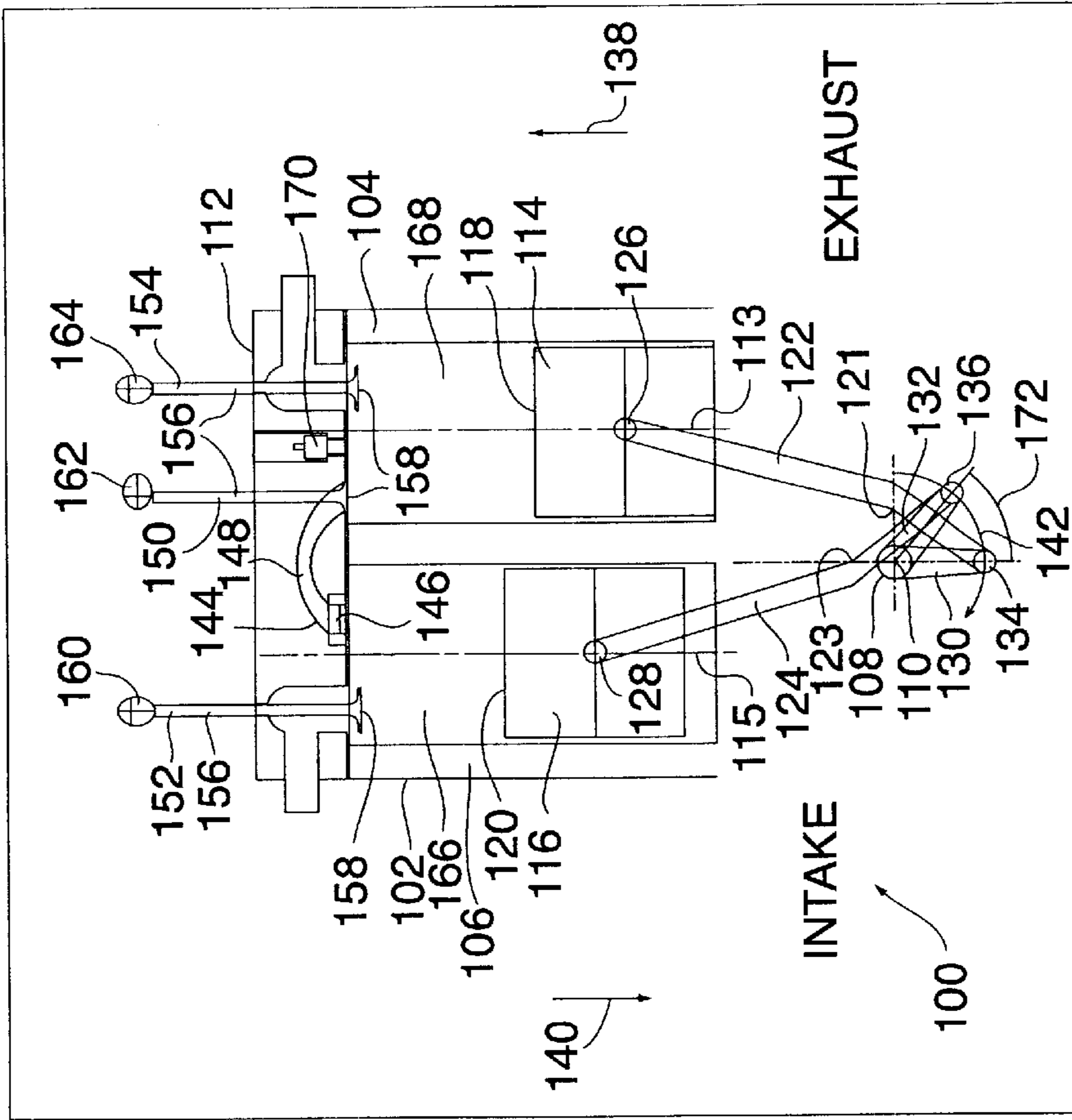

FIG. 7



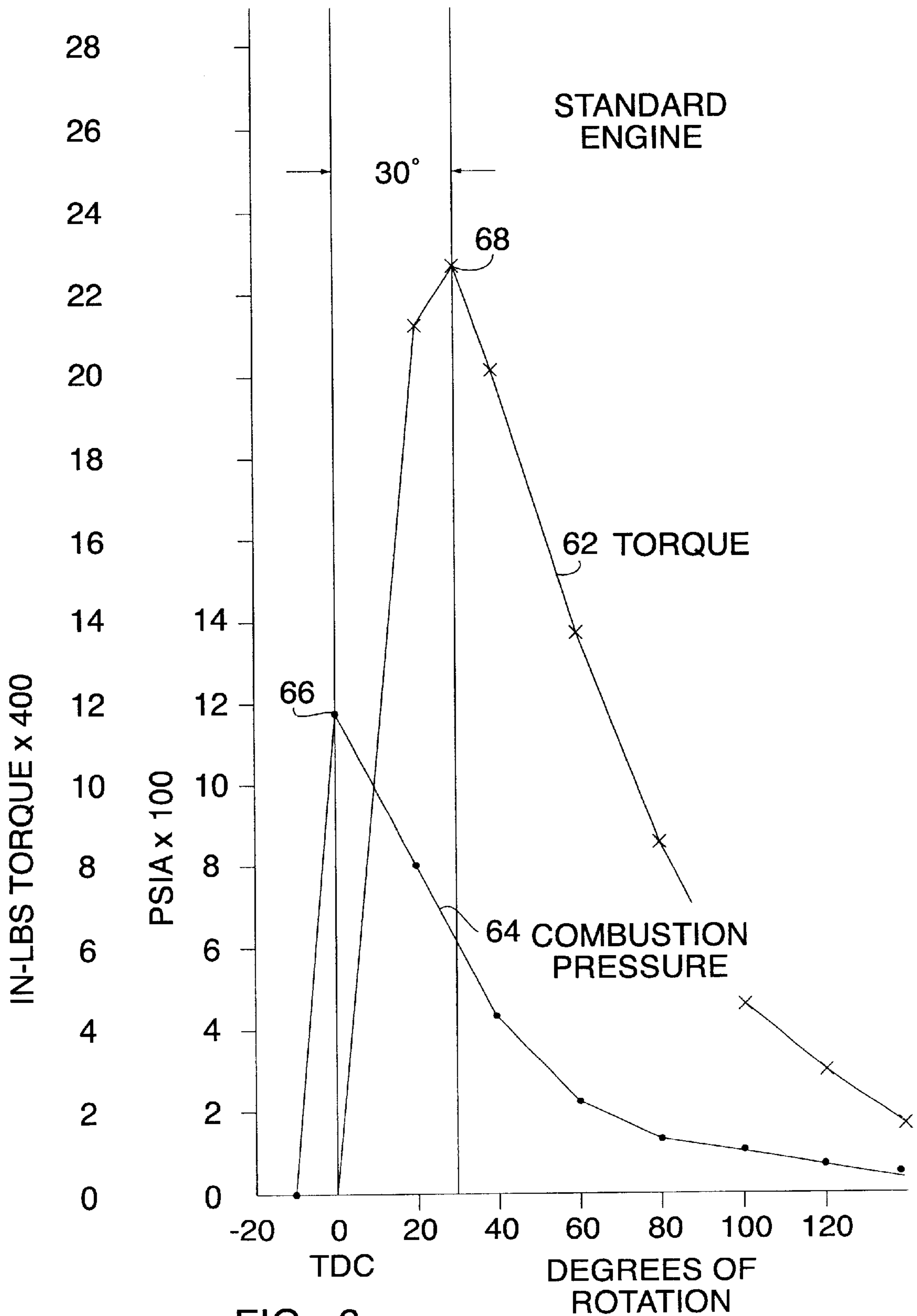

FIG. 6  
PRIOR ART

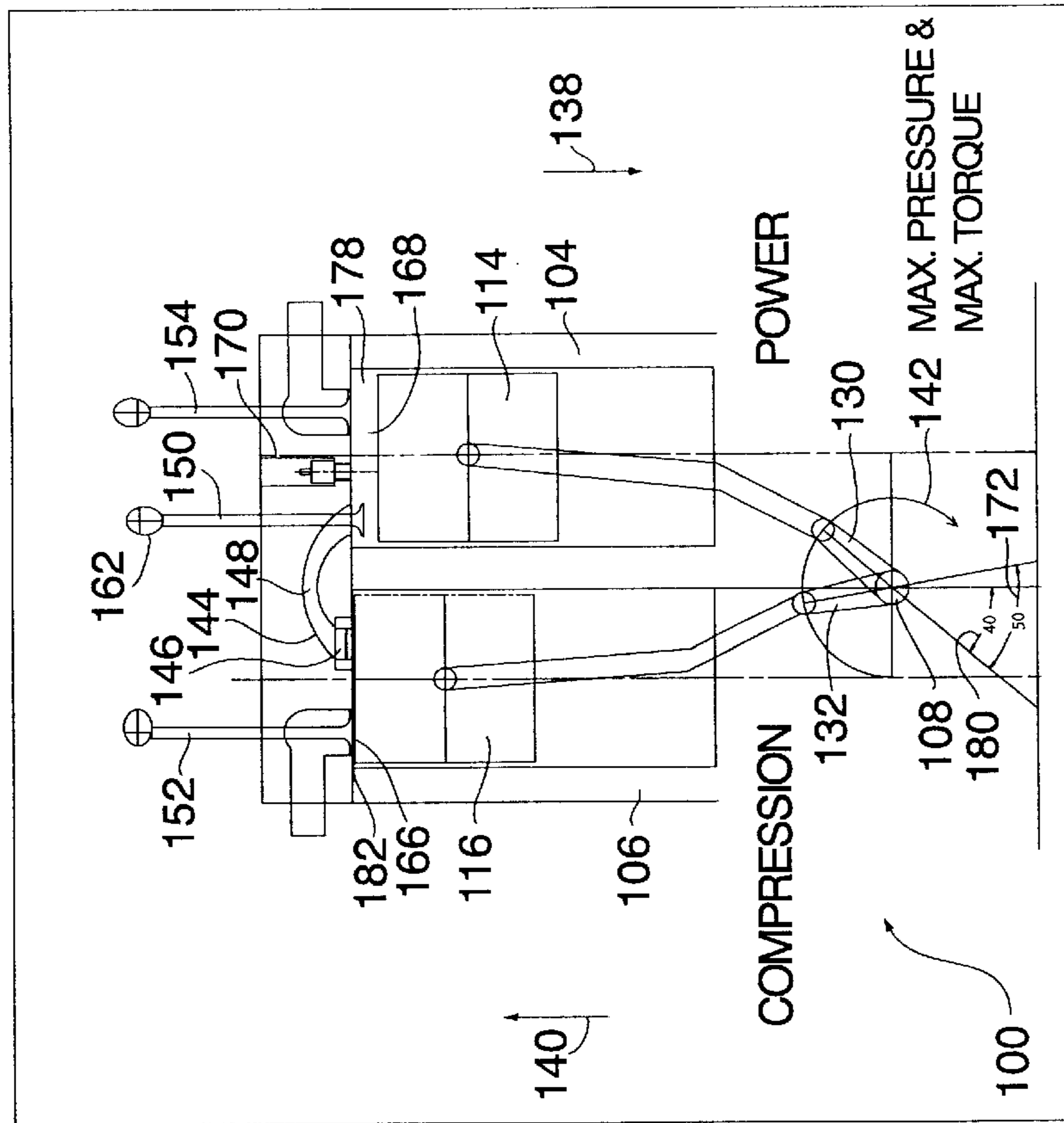

FIG. 9

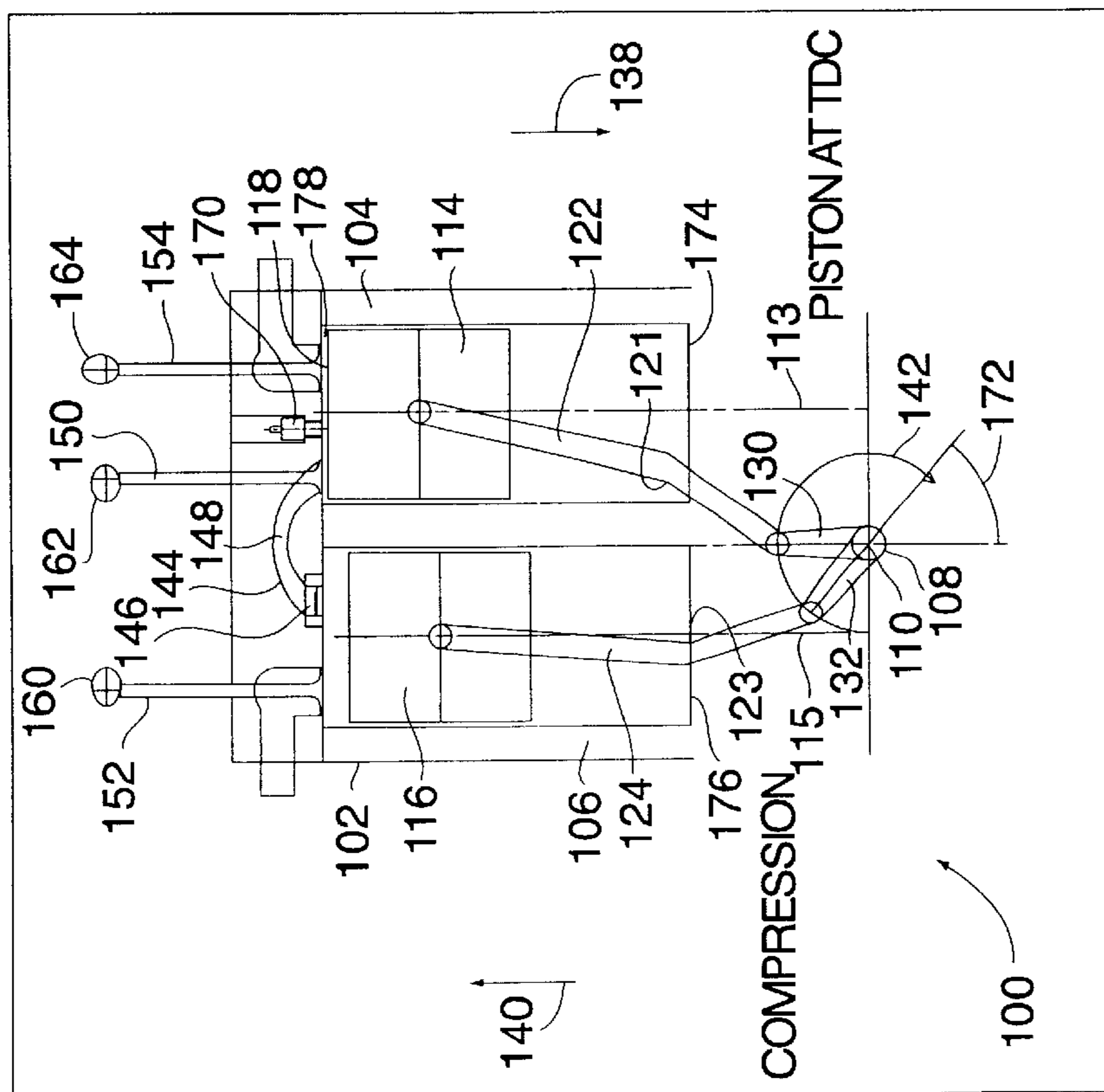

FIG. 8

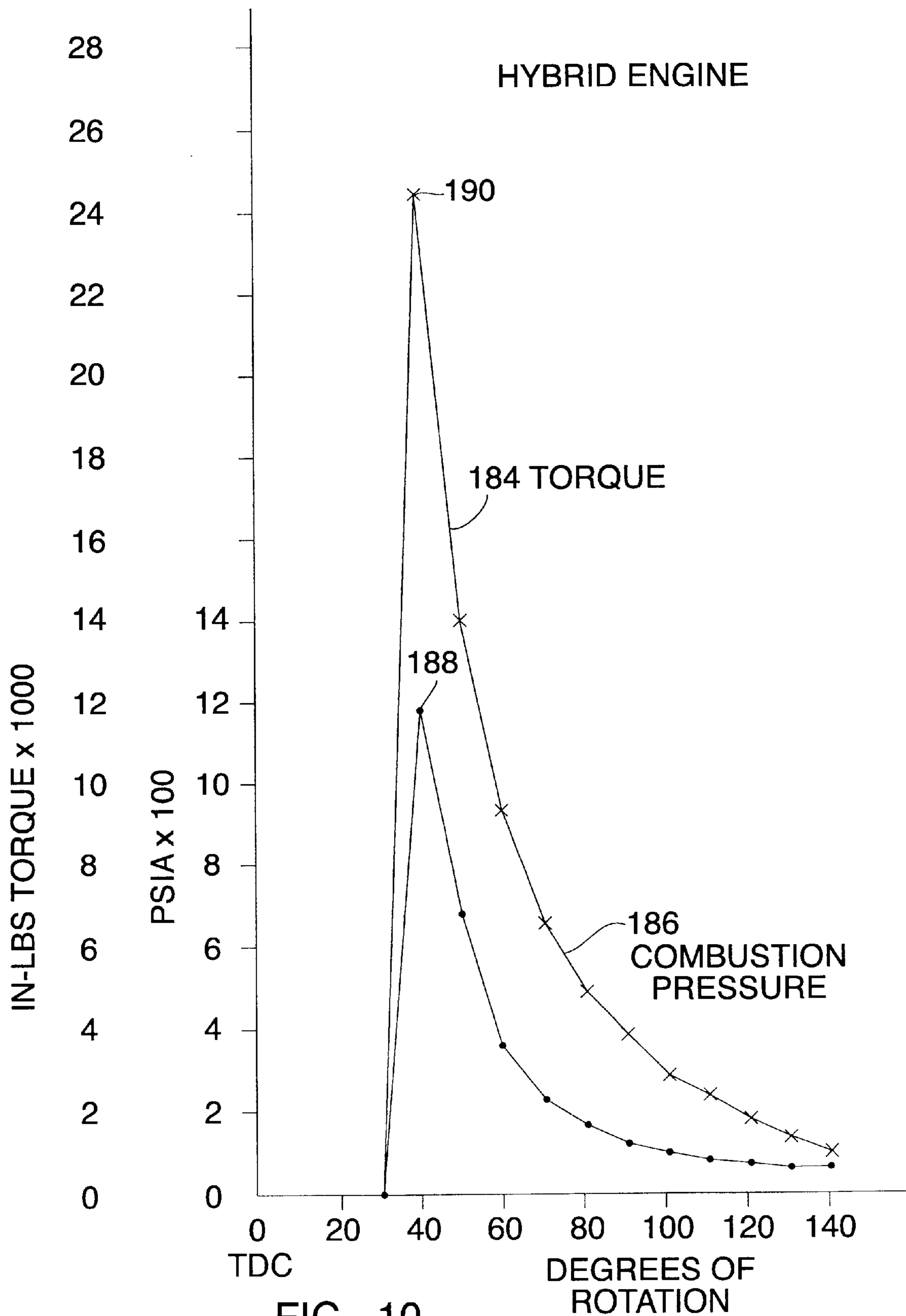

FIG. 10



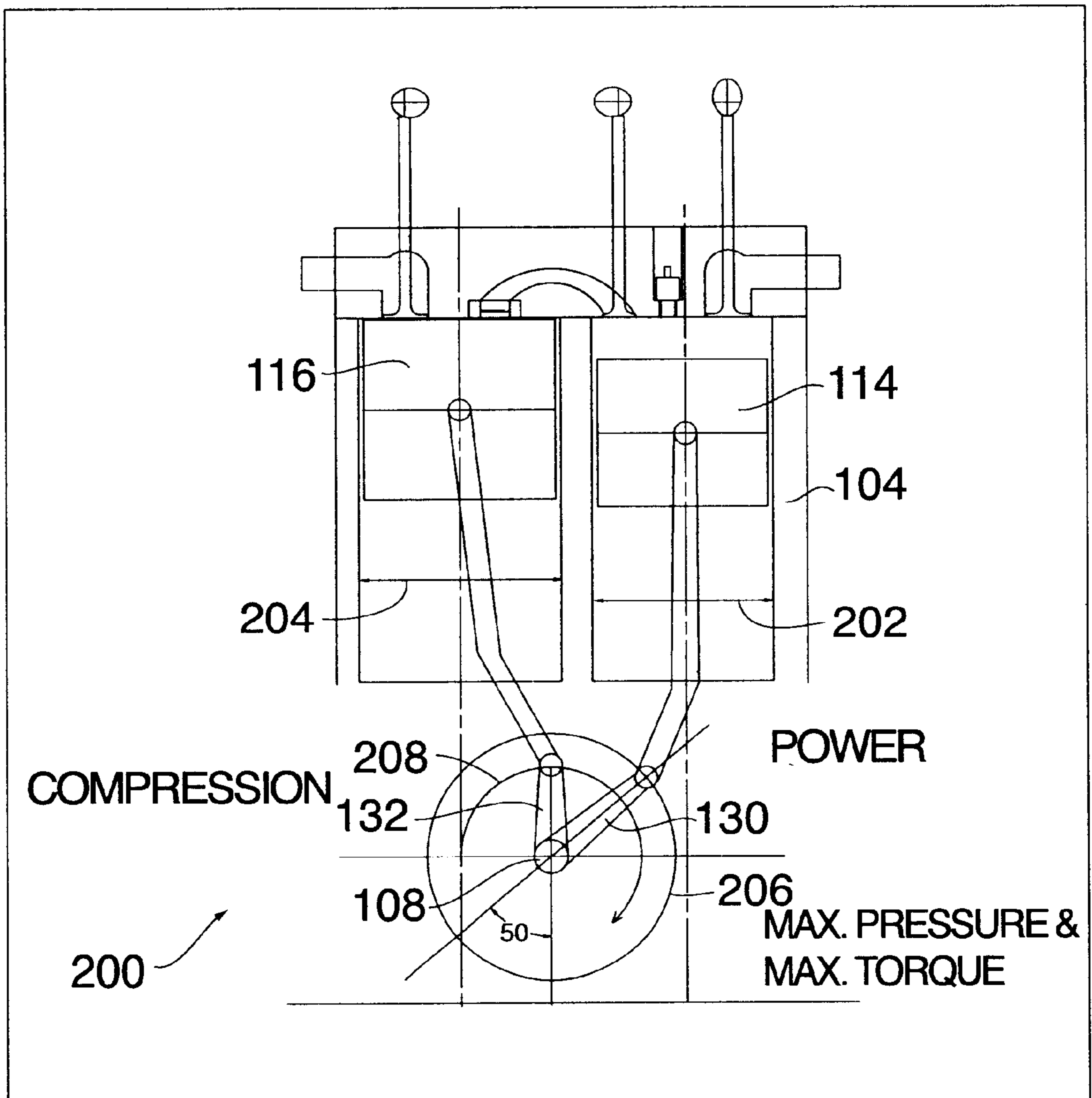

FIG. 11

## SPLIT FOUR STROKE CYCLE INTERNAL COMBUSTION ENGINE

### FIELD OF THE INVENTION

The present invention relates to internal combustion engines. More specifically, the present invention relates to a four-stroke cycle internal combustion engine having a pair of offset pistons in which one piston of the pair is used for the intake and compression strokes and another piston of the pair is used for the power and exhaust strokes, with each four stroke cycle being completed in one revolution of the crankshaft.

### BACKGROUND OF THE INVENTION

Internal combustion engines are any of a group of devices in which the reactants of combustion, e.g., oxidizer and fuel, and the products of combustion serve as the working fluids of the engine. The basic components of an internal combustion engine are well known in the art and include the engine block, cylinder head, cylinders, pistons, valves, crankshaft and camshaft. The cylinder heads, cylinders and tops of the pistons typically form combustion chambers into which fuel and oxidizer (e.g., air) is introduced and combustion takes place. Such an engine gains its energy from the heat released during the combustion of the non-reacted working fluids, e.g., the oxidizer-fuel mixture. This process occurs within the engine and is part of the thermodynamic cycle of the device. In all internal combustion engines, useful work is generated from the hot, gaseous products of combustion acting directly on moving surfaces of the engine, such as the top or crown of a piston. Generally, reciprocating motion of the pistons is transferred to rotary motion of a crankshaft via connecting rods.

Internal combustion (IC) engines can be categorized into spark ignition (SI) and compression ignition (CI) categories. SI engines, i.e. typical gasoline engines, use a spark to ignite the air-fuel mixture, while the heat of compression ignites the air fuel mixture in CI engines, i.e., typically diesel engines.

The most common internal-combustion engine is the four-stroke cycle engine, a conception whose basic design has not changed for more than 100 years old. This is because of its outstanding performance as a prime mover in the ground transportation industry. In a four-stroke cycle engine, power is recovered from the combustion process in four separate piston movements (strokes) of a single piston. For purposes herein, a stroke is defined as a complete movement of a piston from a top dead center position to a bottom dead center position or vice versa. Accordingly, a four-stroke cycle engine is defined herein to be an engine which requires four complete strokes of one or more pistons for every power stroke, i.e. for every stroke that delivers power to a crankshaft.

Referring to FIGS. 1-4, an exemplary embodiment of a prior art four stroke cycle internal combustion engine is shown at 10. For purposes of comparison, the following four FIGS. 1-4 describe what will be termed a prior art "standard engine" 10. As will be explained in greater detail hereinafter, this standard engine 10 is an SI engine with a 4 inch diameter piston, a 4 inch stroke and an 8 to 1 compression ratio. The compression ratio is defined herein as the maximum volume of a predetermined mass of an air-fuel mixture before a compression stroke, divided by the volume of the mass of the air-fuel mixture at the point of ignition. For the standard

volume in cylinder 14 when piston 16 is at bottom dead center to the volume in the cylinder 14 when the piston 16 is at top dead center.

The engine 10 includes an engine block 12 having the cylinder 14 extending therethrough. The cylinder 14 is sized to receive the reciprocating piston 16 therein. Attached to the top of the cylinder 14 is the cylinder head 18, which includes an inlet valve 20 and an outlet valve 22. The cylinder head 18, cylinder 14 and top (or crown 24) of the piston 16 form a combustion chamber 26. On the inlet stroke (FIG. 1), a fuel air mixture is introduced into the combustion chamber 26 through an intake passage 28 and the inlet valve 20, wherein the mixture is ignited via spark plug 30. The products of combustion are later exhausted through outlet valve 22 and outlet passage 32 on the exhaust stroke (FIG. 4). A connecting rod 34 is pivotally attached at its top distal end 36 to the piston 16. A crankshaft 38 includes a mechanical offset portion called the crankshaft throw 40, which is pivotally attached to the bottom distal end 42 of connecting rod 34. The mechanical linkage of the connecting rod 34 to the piston 16 and crankshaft throw 40 serves to convert the reciprocating motion (as indicated by arrow 44) of the piston 16 to the rotary motion (as indicated by arrow 46) of the crankshaft 38. The crankshaft 38 is mechanically linked (not shown) to an inlet camshaft 48 and an outlet camshaft 50, which precisely control the opening and closing of the inlet valve 20 and outlet valve 22 respectively.

The cylinder 14 has a centerline (piston-cylinder axis) 52, which is also the centerline of reciprocation of the piston 16. The crankshaft 38 has a center of rotation (crankshaft axis) 54. For purposes of this specification, the direction of rotation 46 of the crankshaft 38 will be in the clockwise direction as viewed by the reader into the plane of the paper. The centerline 52 of the cylinder 14 passes directly through the center of rotation 54 of the crankshaft 38.

Referring to FIG. 1, with the inlet valve 20 open, the piston 16 first descends (as indicated by the direction of arrow 44) on the intake stroke. A predetermined mass of an explosive mixture of fuel (gasoline vapor) and air is drawn into the combustion chamber 26 by the partial vacuum thus created. The piston continues to descend until it reaches its bottom dead center (BDC), the point at which the piston is farthest from the cylinder head 18.

Referring to FIG. 2, with both the inlet 20 and outlet 22 valves closed, the mixture is compressed as the piston 16 ascends (as indicated by the direction of arrow 44) on the compression stroke. As the end of the stroke approaches top dead center (TDC), i.e., the point at which the piston 16 is closest to the cylinder head 18, the volume of the mixture is compressed to one eighth of its initial volume (due to an 8 to 1 compression ratio). The mixture is then ignited by an electric spark from spark plug 30.

Referring to FIG. 3, the power stroke follows with both valves 20 and 22 still closed. The piston 16 is driven downward (as indicated by arrow 44) toward bottom dead center (BDC), due to the expansion of the burned gas pressing on the crown 24 of the piston 16. Since the spark plug 30 is fired when the piston 16 is at or near TDC, i.e. at its firing position, the combustion pressure (indicated by arrow 56) exerted by the ignited gas on the piston 16 is at its maximum at this point. This pressure 56 is transmitted through the connecting rod 34 and results in a tangential force or torque (as indicated by arrow 58) on the crankshaft 38.

When the piston 16 is at its firing position, there is a significant clearance distance 60 between the top of the



cylinder **14** and the crown **24** of the piston **16**. Typically, the clearance distance is between 0.5 to 0.6 inches. For the standard engine **10** illustrated the clearance distance is substantially 0.571 inches. When the piston **16** is at its firing position conditions are optimal for ignition, i.e., optimal firing conditions. For purposes of comparison, the firing conditions of this engine **10** exemplary embodiment are: 1) a 4 inch diameter piston, 2) a clearance volume of 7.181 cubic inches, 3) a pressure before ignition of approximately 270 pounds per square inch absolute (psia), 4) a maximum combustion pressure after ignition of approximately 1200 psia and 5) operating at 1400 RPM.

This clearance distance **60** corresponds typically to the 8 to 1 compression ratio. Typically SI engines operate optimally with a fixed compression ratio within a range of about 6.0 to 8.5, while the compression ratios of CI engines typically range from about 10 to 16. The piston's **16** firing position is generally at or near TDC, and represents the optimum volume and pressure for the fuel-air mixture to ignite. If the clearance distance **60** were made smaller, the pressure would increase rapidly.

Referring to FIG. **4**, during the exhaust stroke, the ascending piston **16** forces the spent products of combustion through the open outlet (or exhaust) valve **22**. The cycle then repeats itself. For this prior art four stroke cycle engine **10** four strokes of each piston **16**, i.e. inlet, compression, power and exhaust, and two revolutions of the crankshaft **38** are required to complete a cycle, i.e. to provide one power stroke.

Problematically, the overall thermodynamic efficiency of the standard four stroke engine **10** is only about one third ( $\frac{1}{3}$ ). That is  $\frac{1}{3}$  of the work is delivered to the crankshaft,  $\frac{1}{3}$  is lost in waste heat, and  $\frac{1}{3}$  is lost out of the exhaust.

As illustrated in FIGS. **3** and **5**, one of the primary reasons for this low efficiency is the fact that peak torque and peak combustion pressure are inherently locked out of phase. FIG. **3** shows the position of the piston **16** at the beginning of a power stroke, when the piston **16** is in its firing position at or near TDC. When the spark plug **30** fires, the ignited fuel exerts maximum combustion pressure **56** on the piston **16**, which is transmitted through the connecting rod **34** to the crankshaft throw **40** of crankshaft **38**. However, in this position, the connecting rod **34** and the crankshaft throw **40** are both nearly aligned with the centerline **52** of the cylinder **14**. Therefore the torque **58** is almost perpendicular to the direction of force **56**, and is at its minimum value. The crankshaft **38** must rely on momentum generated from an attached flywheel (not shown) to rotate it past this position.

Referring to FIG. **5**, as the ignited gas expands in the combustion chamber **26**, the piston **16** descends and the combustion pressure **56** decreases. However, as the crankshaft throw **40** rotates past the centerline **52** and TDC, the resulting tangential force or torque **58** begins to grow. The torque **58** reaches a maximum value when the crankshaft throw **40** rotates approximately 30 degrees past the centerline **52**. Rotation beyond that point causes the pressure **56** to fall off so much that the torque **58** begins to decrease again, until both pressure **56** and torque **58** reach a minimum at BDC. Therefore, the point of maximum torque **58** and the point of maximum combustion pressure **56** are inherently locked out of phase by approximately 30 degrees.

Referring to FIG. **6**, this concept can be further illustrated. Here, a graph of tangential force or torque versus degrees of rotation from TDC to BDC is shown at **62** for the standard prior art engine **10**. Additionally, a graph of combustion pressure versus degrees of rotation from TDC to BDC is

shown at **64** for engine **10**. The calculations for the graphs **62** and **64** were based on the standard prior art engine **10** having a four inch stroke, a four inch diameter piston, and a maximum combustion pressure at ignition of about 1200 PSIA. As can be seen from the graphs, the point of maximum combustion pressure **66** occurs at approximately 0 degrees from TDC and the point of maximum torque **68** occurs approximately 30 degrees later when the pressure **64** has been reduced considerably. Both graphs **62** and **64** approach their minimum values at BDC, or substantially 180 degrees of rotation past TDC.

An alternative way of increasing the thermal dynamic efficiency of a four stroke cycle engine is to increase the compression ratio of the engine. However, automotive manufactures have found that SI engines typically operate optimally with a compression ratio within a range of about 6.0 to 8.5, while CI engines typically operate best within a compression ratio range of about 10 to 16. This is because as the compression ratios of SI or CI engines increase substantially beyond the above ranges, several other problems occur, which outweigh the advantages gained. For example, the engine must be made heavier and bulkier in order to handle the greater pressures involved. Also problems of premature ignition begin to occur, especially in SI engines.

Many rather exotic early engine designs were patented. However, none were able to offer greater efficiencies or other significant advantages, which would replace the standard engine **10** exemplified above. Some of these early patents included: U.S. Pat. Nos. 848,029; 939,376; 1,111,841; 1,248,250; 1,301,141; 1,392,359; 1,856,048; 1,969,815; 2,091,410; 2,091,411; 2,091,412; 2,091,413; 2,269,948; 3,895,614; British Pat. No. 299,602; British Pat. No. 721,025 and Italian Pat. No. 505,576.

In particular the U.S. Pat. No. 1,111,841 to Koenig disclosed a prior art split piston/cylinder design in which an intake and compression stroke was accomplished in a compression piston 12/cylinder 11 combination, and a power and an exhaust stroke was accomplished in an engine piston 7/cylinder 8 combination. Each piston 7 and 12 reciprocates along a piston cylinder axis which intersected the single crankshaft 5 (see FIG. 3 therein). A thermal chamber 24 connects the heads of the compression and engine cylinders, with one end being open to the engine cylinder and the other end having a valved discharge port 19 communicating with the compressor cylinder. A water cooled heat exchanger 15 is disposed at the top of the compressor cylinder 11 to cool the air or air/fuel mixture as it is compressed. A set of spaced thermal plates 25 are disposed within the thermal chamber 24 to re-heat the previously cooled compressed gas as it passes through.

It was thought that the engine would gain efficiency by making it easier to compress the gas by cooling it. Thereafter, the gas was re-heated in the thermal chamber in order to increase its pressure to a point where efficient ignition could take place. Upon the exhaust stroke, hot exhaust gases were passed back through the thermal chamber and out of an exhaust port **26** in an effort to re-heat the thermal chamber.

Unfortunately, transfer of gas in all prior art engines of a split piston design always requires work which reduces efficiency. Additionally, the added expansion from the thermal chamber to the engine cylinder of Koenig also reduced compression ratio. The standard engine **10** requires no such transfer process and associated additional work. Moreover, the cooling and re-heating of the gas, back and forth through



the thermal chamber did not provide enough of an advantage to overcome the losses incurred during the gas transfer process. Therefore, the Koenig patent lost efficiency and compression ratio relative to the standard engine 10.

For purposes herein, a crankshaft axis is defined as being offset from the piston cylinder axis when the crankshaft axis and the piston-cylinder axis do not intersect. The distance between the extended crankshaft axis and the extended piston-cylinder axis taken along a line drawn perpendicular to the piston cylinder axis is defined as the offset. Typically, offset pistons are connected to the crankshaft by well-known connecting rods and crankshaft throws. However, one skilled in the art would recognize that offset pistons may be operatively connected to a crankshaft by several other mechanical linkages. For example, a first piston may be connected to a first crankshaft and a second piston may be connected to a second crankshaft, and the two crankshafts may be operatively connected together through a system of gears. Alternatively, pivoted lever arms or other mechanical linkages may be used in conjunction with, or in lieu of, the connecting rods and crankshaft throws to operatively connect the offset pistons to the crankshaft.

However, all of the improvements gained were due to increasing the torque angles on the power stroke only. Unfortunately, as will be discussed in greater detail hereinafter, the greater the advantage an offset was to the power stroke was also accompanied by an associated increasing disadvantage to the compression stroke. Therefore the degree of offset quickly becomes self limiting, wherein the advantages to torque, power, friction and vibration to the power stroke do not outweigh the disadvantages to the same functions on the compression stroke. Additionally, no advantages were taught or discussed regarding offsets to optimize the compression stroke.

By way of example, a recent prior art attempt to increase efficiency in a standard engine 10 type design through the use of an offset is disclosed in U.S. Pat. No. 6,058,901 to Lee. Lee believes that improved efficiency will result by reducing the frictional forces of the piston rings on the side walls over the full duration of two revolutions of a four stroke cycle (see Lee, column 4, lines 10-16). Lee attempts to accomplish this by providing an offset cylinder, wherein the timing of combustion within each cylinder is controlled to cause maximum combustion pressure to occur when an imaginary plane that contains both a respective connection axis of a respective connecting rod to the respective piston and a respective connection axis of the connecting rod to a respective throw of the crankshaft is substantially coincident with the respective cylinder axis along which the piston reciprocates.

However, though the offset is an advantage during the power stroke, it becomes a disadvantage during the compression stroke. That is, when the piston travels from bottom dead center to top dead center during the compression stroke, the offset piston-cylinder axis creates an angle between the crankshaft throw and connecting rod that reduces the torque applied to the piston. Additionally, the side forces resulting from the poor torque angles on the compression stroke actually increase wear on the piston rings. Accordingly, a greater amount of power must be consumed in order to compress the gas to complete the compression stroke as the offset increases. Therefore the amount of offset is severely limited by its own disadvantages on the compression side. Accordingly, large prior art offsets, i.e., offsets in which the crankshaft must rotate at least 20 degrees past a piston's top dead center position before the piston can reach a firing position, have not been utilized,

disclosed or taught. As a result, the relatively large offsets required to substantially align peak torque to peak combustion pressure cannot be accomplished with Lee's invention.

Variable Compression Ratio (VCR) engines are a class of prior art CI engines designed to take advantage of varying the compression ratio on an engine to increase efficiency. One such typical example is disclosed in U.S. Pat. No. 4,955,328 to Sobotowski. Sobotowski describes an engine in which compression ratio is varied by altering the phase relation between two pistons operating in cylinders interconnected through a transfer port that lets the gas flow in both directions.

However, altering the phase relation to vary compression ratios impose design requirements on the engine that greatly increase its complexity and decrease its utility. For example, each piston of the pair of pistons must reciprocate through all four strokes of a complete four stroke cycle, and must be driven by a pair of crankshafts which rotate through two full revolutions per four stroke cycle. Additionally, the linkages between the pair of crankshafts become very complex and heavy. Also the engine is limited by design to CI engines due to the higher compression ratios involved.

Various other relatively recent specialized prior art engines have also been designed in an attempt to increase engine efficiency. One such engine is described in U.S. Pat. No. 5,546,897 to Brackett titled Internal Combustion Engine with Stroke Specialized Cylinders. In Brackett the engine is divided into a working section and a compressor section. The compressor section delivers charged air to the working section, which utilizes a scotch yoke or conjugate drive motion translator design to enhance efficiency. The specialized engine can be described as a horizontally opposed engine in which a pair of opposed pistons reciprocate in opposing directions within one cylinder block.

However, the compressor is designed essentially as a super charger which delivers supercharged gas to the working section. Each piston in the working section must reciprocate through all four strokes of intake, compression, power and exhaust, as each crankshaft involved must complete two full revolutions per four-stroke cycle. Additionally, the design is complex, expensive and limited to very specialized CI engines.

Another specialized prior art design is described in U.S. Pat. No. 5,623,894 to Clarke titled Dual Compression and Dual Expansion Engine. Clarke essentially discloses a specialized two-stroke engine where opposing pistons are disposed in a single cylinder to perform a power stroke and a compression stroke. The single cylinder and the crowns of the opposing pistons define a combustion chamber, which is located in a reciprocating inner housing. Intake and exhaust of the gas into and out of the combustion chamber is performed by specialized conical pistons, and the reciprocating inner housing.

However, the engine is a highly specialized two-stroke system in which the opposing pistons each perform a compression stroke and a power stroke in the same cylinder. Additionally, the design is very complex requiring dual crankshafts, four pistons and a reciprocating inner housing to complete the single revolution two-stroke cycle. Also, the engine is limited to large CI engine applications.

Accordingly, there is a need for an improved four-stroke internal combustion engine, which can enhance efficiency by more closely aligning the torque and force curves generated during a power stroke without increasing compression ratios substantially beyond normally accepted design limits.



## SUMMARY OF THE INVENTION

The present invention offers advantages and alternatives over the prior art by providing a four-stroke cycle internal combustion engine having a pair of pistons in which one piston of the pair is used for the intake and compression strokes and another piston of the pair is used for the power and exhaust strokes, with each four stroke cycle being completed in one revolution of the crankshaft. The engine enhances efficiency by more closely aligning the torque and force curves generated during a power stroke without increasing compression ratios.

These and other advantages are accomplished in an exemplary embodiment of the invention by providing a four stroke cycle internal combustion engine. The engine comprises a crankshaft, rotating about a crankshaft axis of the engine. A power piston is slidably received within a first cylinder and operatively connected to the crankshaft such that the power piston reciprocates through a power stroke and an exhaust stroke of a four stroke cycle during a single rotation of the crankshaft. A compression piston is slidably received within a second cylinder and operatively connected to the crankshaft such that the compression piston reciprocates through an intake stroke and a compression stroke of the same four stroke cycle during the same rotation of the crankshaft. A gas passage interconnects the first and second cylinders. The gas passage includes an inlet valve and an outlet valve defining a pressure chamber therebetween. The inlet valve permits substantially one way flow of compressed gas from the second cylinder to the pressure chamber and the outlet valve permits substantially one way flow of compressed gas from the pressure chamber to the first cylinder.

In an alternative embodiment of the invention the crankshaft of the engine includes a first throw and a second throw. A first connecting rod is pivotally connected to both the power piston and the first throw of the crankshaft. A second connecting rod is pivotally connected to both the compression piston and the second throw of the crankshaft.

In another embodiment of the invention the engine includes a first piston-cylinder axis along which the power piston reciprocates within the first cylinder. The first piston cylinder axis has an offset from the crankshaft axis such that the first piston-cylinder axis does not intersect the crankshaft axis and passes on one side of the crankshaft axis. The engine also includes a second piston-cylinder axis along which the compression piston reciprocates within the second cylinder. The second piston cylinder axis has an offset from the crankshaft axis such that the second piston-cylinder axis does not intersect the crankshaft axis and passes on an opposing side of the crankshaft axis.

In another alternative embodiment of the invention the offset of the first piston-cylinder axis substantially aligns a point of maximum combustion pressure applied to the power piston with a point of maximum torque applied to the crankshaft during the power stroke. Additionally the offset of the second piston-cylinder axis substantially aligns a point of maximum compression pressure applied to the compression piston with a point of maximum torque applied from the crankshaft during the compression stroke.

In another embodiment of the invention the offset of the first piston-cylinder axis is such that the crankshaft must rotate at least 20 degrees past the point where the power piston reaches top dead center, before the power piston can reach a firing position.

## BRIEF DESCRIPTION OF THE DRAWINGS

FIG. 1 is a schematic diagram of a representative prior art four stroke cycle engine during the intake stroke;

FIG. 2 is a schematic diagram of the prior art engine of FIG. 1 during the compression stroke;

FIG. 3 is a schematic diagram of the prior art engine of FIG. 1 during the power stroke;

FIG. 4 is a schematic diagram of the prior art engine of FIG. 1 during the exhaust stroke;

FIG. 5 is a schematic diagram of the prior art engine of FIG. 1 when the piston is at the position of maximum torque;

FIG. 6, is a graphical representation of torque and combustion pressure of the prior art engine of FIG. 1;

FIG. 7 is a schematic diagram of an engine in accordance with the present invention during the exhaust and intake strokes;

FIG. 8 is a schematic diagram of the engine of FIG. 7 when the first piston has just reached top dead center (TDC) at the beginning of a power stroke;

FIG. 9 is a schematic diagram of the engine of FIG. 7 when the first piston has reached its firing position;

FIG. 10, is a graphical representation of torque and combustion pressure of the engine of FIG. 7; and

FIG. 11 is a schematic diagram of an alternative embodiment of an engine in accordance with the present invention having unequal throws and piston diameters.

## DETAILED DESCRIPTION OF THE PREFERRED EMBODIMENTS

Referring to FIG. 7, an exemplary embodiment of a four stroke internal combustion engine in accordance with the present invention is shown generally at **100**. The engine **100** includes an engine block **102** having a first cylinder **104** and a second cylinder **106** extending therethrough. A crankshaft **108** is journaled for rotation about a crankshaft axis **110** (extending perpendicular to the plane of the paper).

The engine block **102** is the main structural member of the engine **100** and extends upward from the crankshaft **108** to the junction with the cylinder head **112**. The engine block **102** serves as the structural framework of the engine **100** and typically carries the mounting pad by which the engine is supported in the chassis (not shown). The engine block **102** is generally a casting with appropriate machined surfaces and threaded holes for attaching the cylinder head **112** and other units of the engine **100**.

The cylinders **104** and **106** are openings, typically of generally circular cross section, that extend through the upper portion of the engine block **102**. Cylinders are defined herein as the chambers within which pistons of an engine reciprocate, and do not have to be generally circular in cross section, e.g., they may have a generally elliptical or half moon shape.

The internal walls of cylinders **104** and **106** are bored and polished to form smooth, accurate bearing surfaces sized to receive a first power piston **114**, and a second compression piston **116** respectively. The power piston **114** reciprocates along a first piston-cylinder axis **113**, and the compression piston **116** reciprocates along a second piston-cylinder axis **115**. The first and second cylinders **104** and **106** are disposed in the engine **100** such that the first and second piston-cylinder axes **113** and **115** pass on opposing sides of the crankshaft axis **110** without intersecting the crankshaft axis **110**.

The pistons **114** and **116** are typically cup shaped cylindrical castings of steel or aluminum alloy. The upper closed ends, i.e., tops, of the power and compression pistons **114** and **116** are the first and second crowns **118** and **120**



respectively. The outer surfaces of the pistons **114**, **116** are generally machined to fit the cylinder bore closely and are typically grooved to receive piston rings (not shown) that seal the gap between the pistons and the cylinder walls.

First and second connecting rods **122** and **124** each include an angle bend **121** and **123** respectively. The connecting rods **122** and **124** are pivotally attached at their top distal ends **126** and **128** to the power and compression pistons **114** and **116** respectively. The crankshaft **108** includes a pair of mechanically offset portions called the first and second throws **130** and **132**, which are pivotally attached to the bottom opposing distal ends **134** and **136** of the first and second connecting rods **122** and **124** respectively. The mechanical linkages of the connecting rods **122** and **124** to the pistons **114**, **116** and crankshaft throws **130**, **132** serve to convert the reciprocating motion of the pistons (as indicated by directional arrow **138** for the power piston **114**, and directional arrow **140** for the compression piston **116**) to the rotary motion (as indicated by directional arrow **142**) of the crankshaft **108**. The first piston cylinder axis **113** is offset such that it is disposed in the imaginary half plane through which the first crankshaft throw **130** rotates from its top dead center position to its bottom dead center position. The second piston cylinder axis **115** is offset in the opposing imaginary half plane.

Though this embodiment shows the first and second pistons **114** and **116** connected directly to crankshaft **108** through connecting rods **122** and **124** respectively, it is within the scope of this invention that other means may also be employed to operatively connect the pistons **114** and **116** to the crankshaft **108**. For example a second crankshaft may be used to mechanically link the pistons **114** and **116** to the first crankshaft **108**.

The cylinder head **112** includes a gas passage **144** interconnecting the first and second cylinders **104** and **106**. The gas passage includes an inlet check valve **146** disposed in a distal end of the gas passage **144** proximate the second cylinder **106**. An outlet poppet valve **150** is also disposed in an opposing distal end of the gas passage **144** proximate the top of the first cylinder **104**. The inlet check valve **146** and outlet poppet valve **150** define a pressure chamber **148** there between. The inlet valve **146** permits the one way flow of compressed gas from the second cylinder **106** to the pressure chamber **148**. The outlet valve **150** permits the one way flow of compressed gas from the pressure chamber **148** to the first cylinder **104**. Though check and poppet type valves are described as the inlet and the outlet valves **146** and **150** respectively, any valve design appropriate for the application may be used instead, e.g., the inlet valve **146** may also be of the poppet type.

The cylinder head **112** also includes an intake valve **152** of the poppet type disposed over the top of the second cylinder **106**, and an exhaust valve **154** of the poppet type disposed over the top to the first cylinder **104**. Poppet valves **150**, **152** and **154** typically have a metal shaft **156** with a disk **158** at one end fitted to block the valve opening. The other end of the shafts **156** of poppet valves **150**, **152** and **154** are mechanically linked to camshafts **160**, **162** and **164** respectively. The camshafts **160**, **162** and **164** are typically a round rod with generally oval shaped lobes located inside the engine block **102** or in the cylinder head **112**.

The camshafts **160**, **162** and **164** are mechanically connected to the crankshaft **108**, typically through a gear wheel, belt or chain links (not shown). When the crankshaft **108** forces the camshafts **160**, **162** and **164** to turn, the lobes on the camshafts **160**, **162** and **164** cause the valves **150**, **152** and **154** to open and close at precise moments in the engine's cycle.

The crown **120** of compression piston **116**, the walls of second cylinder **106** and the cylinder head **112** form a compression chamber **166** for the second cylinder **106**. The crown **118** of power piston **114**, the walls of first cylinder **104** and the cylinder head **112** form a separate combustion chamber **168** for the first cylinder **104**. A spark plug **170** is disposed in the cylinder head **112** over the first cylinder **104** and is controlled by a control device (not shown) which precisely times the ignition of the compressed air gas mixture in the combustion chamber **168**. Though this embodiment describes a spark ignition (SI) engine, one skilled in the art would recognize that compression ignition (CI) engines are within the scope of this invention also.

During operation the power piston **114** leads the compression piston **116** by a phase shift angle **172**, defined by the degrees of rotation the crankshaft **108** must rotate after the power piston **114** has reached its top dead center position in order for the compression piston **116** to reach its respective top dead center position. Preferably this phase shift is between 30 to 60 degrees. For this particular preferred embodiment the phase shift is fixed substantially at 50 degrees.

FIG. 7 illustrates the power piston **114** when it has reached its bottom dead center (BDC) position and has just started ascending (as indicated by arrow **138**) into its exhaust stroke. Compression piston **116** is lagging the power piston **114** by 50 degrees and is descending (arrow **140**) through its intake stroke. The inlet valve **156** is open to allow an explosive mixture of fuel and air to be drawn into the compression chamber **166**. The exhaust valve **154** is also open allowing piston **114** to force spent products of combustion out of the combustion chamber **168**.

The check valve **146** and poppet valve **150** of the gas passage **144** are closed to prevent the transfer of ignitable fuel and spent combustion products between the two chambers **166** and **168**. Additionally during the exhaust and intake strokes, the inlet check valve **146** and outlet poppet valve **150** seal the pressure chamber **148** to substantially maintain the pressure of any gas trapped therein from the previous compression and power strokes.

Referring to FIG. 8, the power piston **114** has reached its top dead center (TDC) position and is about to descend into its power stroke (indicated by arrow **138**), while the compression piston **116** is ascending through its compression stroke (indicated by arrow **140**). At this point, inlet check valve **146**, outlet valve **150**, intake valve **152** and exhaust valve **154** are all closed.

At TDC piston **114** has a clearance distance **178** between the crown **118** of the piston **114** and the top of the cylinder **104**. This clearance distance **178** is very small by comparison to the clearance distance **60** of standard engine **10** (best seen in FIG. 3). This is because the power stroke in engine **100** follows a low pressure exhaust stroke, while the power stroke in standard engine **10** follows a high pressure compression stroke. Therefore, in distinct contrast to the standard engine **10**, there is little penalty to engine **100** to reduce the clearance distance **178** since there is no high pressure gas trapped between the crown **118** and the top of the cylinder **104**. Moreover, by reducing the clearance distance **178**, a more thoroughly flushing of nearly all exhaust products is accomplished.

In order to substantially align the point of maximum torque with maximum combustion pressure, the crankshaft **108** must be rotated approximately 40 degrees past its top dead center position when the power piston **114** is in its optimal firing position. Additionally, similar considerations



hold true on the compression piston **116**, in order to reduce the amount of torque and power consumed by the crankshaft **108** during a compression stroke. Both of these considerations require that the offsets on the piston-cylinder axes be much larger than any previous prior art offsets, i.e., offsets in which the crankshaft must rotate at least 20 degrees past a pistons top dead center position before the piston can reach a firing position. These offsets are in fact so large that a straight connecting rod linking the pistons **114** and **116** would interfere with the lower distal end of the cylinders **104** and **106** during a stroke.

Accordingly, the bend **121** in connecting rod **122** must be disposed intermediate its distal ends and have a magnitude such that the connecting rod **122** clears the bottom distal end **174** of cylinder **104** while the power piston **114** reciprocates through an entire stroke. Additionally, the bend **123** in connecting rod **124** must be disposed intermediate its distal ends and have a magnitude such that the connecting rod **124** clears the bottom distal end **176** of cylinder **106** while the compression piston **116** reciprocates through an entire stroke.

Referring to FIG. 9, the crankshaft **108** has rotated an additional 40 degrees (as indicated by arrow **180**) past the TDC position of power piston **114** to reach its firing position, and the compression piston **116** is just completing its compression stroke. During this 40 degrees of rotation, the compressed gas within the second cylinder **106** reaches a threshold pressure which forces the check valve **146** to open, while cam **162** is timed to also open outlet valve **150**. Therefore, as the power piston **114** descends and the compression piston **116** ascends, a substantially equal mass of compressed gas is transferred from the compression chamber **166** of the second cylinder **106** to the combustion chamber **168** of the first cylinder **104**. When the power piston **114** reaches its firing position, check valve **146** and outlet valve **150** close to prevent any further gas transfer through pressure chamber **148**. Accordingly, the mass and pressure of the gas within the pressure chamber **148** remain relatively constant before and after the gas transfer takes place. In other words, the gas pressure within the pressure chamber **148** is maintained at least (at or above) a predetermined firing condition pressure, e.g., approximately 270 psia, for the entire four stroke cycle.

By the time the power piston **114** has descended to its firing position from TDC, the clearance distance **178** has grown to substantially equal that of the clearance distance **60** of standard engine **10** (best seen in FIG. 3), i.e., 0.571. Additionally, the firing conditions are substantially the same as the firing conditions of the standard engine **10**, which are generally: 1) a 4 inch diameter piston, 2) a clearance volume of 7.181 cubic inches, 3) a pressure before ignition of approximately 270 pounds per square inch absolute (psia), and 4) a maximum combustion pressure after ignition of approximately 1200 psia. Moreover, the angle of the first throw **130** of crankshaft **108** is in its maximum torque position, i.e., approximately 40 degrees past TDC. Therefore, spark plug **170** is timed to fire such that maximum combustion pressure occurs when the power piston **114** substantially reaches its position of maximum torque.

During the next 10 degrees of rotation **142** of the crankshaft **108**, the compression piston **116** will pass through to its TDC position and thereafter start another intake stroke to begin the cycle over again. The compression piston **116** also has a very small clearance distance **182** relative to the standard engine **10**. This is possible because, as the gas pressure in the compression chamber **166** of the second cylinder **106** reaches the pressure in the pressure chamber

**148**, the check valve **146** is forced open to allow gas to flow through. Therefore, very little high pressure gas is trapped at the top of the power piston **116** when it reaches its TDC position.

The compression ratio of engine **100** can be anything within the realm of SI or CI engines, but for this exemplary embodiment it is substantially within the range of 6 to 8.5. As defined earlier, the compression ratio is the maximum volume of a predetermined mass of an air-fuel mixture before a compression stroke, divided by the volume of the mass of the air-fuel mixture at the point of ignition. For the engine **100**, the compression ratio is substantially the ratio of the displacement volume in second cylinder **106** when the compression piston **116** travels from BDC to TDC to the volume in the first cylinder **104** when the power piston **114** is at its firing position.

In distinct contrast to the standard engine **10** where the compression stroke and the power stroke are always performed in sequence by the same piston, the power stroke is performed by the power piston **114** only, and the compression stroke is performed by the compression piston **116** only. Therefore, the power piston **114** can be offset to align maximum combustion pressure with maximum torque applied to the crankshaft **108** without incurring penalty for being out of alignment on the compression stroke. Vice versa, the compression piston **116** can be offset to align maximum compression pressure with maximum torque applied from the crankshaft **108** without incurring penalty for being out of alignment on the power stroke.

Referring to FIG. 10, this concept can be further illustrated. Here, a graph of tangential force or torque versus degrees of rotation from TDC for power piston **114** is shown at **184** for the engine **100**. Additionally, a graph of combustion pressure versus degrees of rotation from TDC for power piston **114** is shown at **186** for engine **100**. The calculations for the graphs **184** and **186** were based on the engine **100** having firing conditions substantially equal to that of a standard engine. That is: 1) a 4 inch diameter piston, 2) a clearance volume of 7.181 cubic inches, 3) a pressure before ignition of approximately 270 pounds per square inch absolute (psia), 4) a maximum combustion pressure after ignition of approximately 1200 psia and 5) substantially equal revolutions per minute (RPM) of the crankshafts **108** and **38**. In distinct contrast with the graphs of FIG. 6 for the standard prior art engine **10**, the point of maximum combustion pressure **188** is substantially aligned with the point of maximum torque **190**. This alignment of combustion pressure **186** with torque **184** results in a significant increase in efficiency.

Moreover, the compression piston's **116** offset can also be optimized to substantially align the maximum torque delivered to the compression piston **116** from the crankshaft **108** with the maximum compression pressure of the gas. The compression piston's **116** offset reduces the amount of power exerted in order to complete a compression stroke and further increases the overall efficiency of engine **100** relative to the standard engine **10**. With the combined power and compression piston **114**, and **116** offsets, the overall theoretical efficiency of engine **100** can be increased by approximately 20 to 40 percent relative to the standard engine.

Referring to FIG. 11, an alternative embodiment of a split four stroke engine having unequal throws and unequal piston diameters is shown generally at **200**. Because the compression and power strokes are performed by separate pistons **114**, **116**, various enhancements can be made to optimize the efficiency of each stroke without the associated



## 13

penalties incurred when the strokes are performed by a single piston. For example, the compression piston diameter **204** can be made larger than the power piston diameter **202** to further increase the efficiency of compression. Additionally, the radius **206** of the first throw **130** for the power piston **114** can be made larger than the radius **208** of the second throw **132** for the compression piston **116** to further enhance the total torque applied to the crankshaft **108**.

While preferred embodiments have been shown and described, various modifications and substitutions may be made thereto without departing from the spirit and scope of the invention. Accordingly, it is to be understood that the present invention has been described by way of illustration and not limitation.

What is claimed is:

**1.** A four stroke cycle internal combustion engine comprising:

- a crankshaft, rotating about a crankshaft axis of the engine;
- a power piston slidably received within a first cylinder and operatively connected to the crankshaft such that the power piston reciprocates through a power stroke and an exhaust stroke of a four stroke cycle during a single rotation of the crankshaft;
- a compression piston slidably received within a second cylinder and operatively connected to the crankshaft such that the compression piston reciprocates through an intake stroke and a compression stroke of the same four stroke cycle during the same rotation of the crankshaft; and
- a gas passage interconnecting the first and second cylinders, the gas passage including an inlet valve and an outlet valve defining a pressure chamber therebetween,

wherein the inlet valve and the outlet valve of the gas passage substantially maintain at least a predetermined firing condition gas pressure in the pressure chamber during the entire four stroke cycle.

**2.** The engine of claim **1** comprising:

- the crankshaft having a first throw and a second throw;
- a first connecting rod pivotally connected to both the power piston and the first throw of the crankshaft; and
- a second connecting rod pivotally connected to both the compression piston and the second throw of the crankshaft.

**3.** The engine of claim **2** comprising:

- a first piston-cylinder axis along which the power piston reciprocates within the first cylinder, wherein the first piston cylinder axis has an offset from the crankshaft axis such that the first piston-cylinder axis does not intersect the crankshaft axis and passes on one side of the crankshaft axis.

**4.** The engine of claim **3** comprising:

- a second piston-cylinder axis along which the compression piston reciprocates within the second cylinder, wherein the second piston cylinder axis has an offset from the crankshaft axis such that the second piston-cylinder axis does not intersect the crankshaft axis and passes on an opposing side of the crankshaft axis.

**5.** The engine of claim **3** wherein the offset of the first piston-cylinder axis substantially aligns a point of maximum combustion pressure applied to the power piston with a point of maximum torque applied to the crankshaft during the power stroke.

## 14

**6.** The engine of claim **3** wherein the offset of the first piston-cylinder axis is such that the crankshaft must rotate at least 20 degrees past the point where the power piston reaches top dead center, before the power piston can reach a firing position.

**7.** The engine of claim **4** wherein the offset of the second piston-cylinder axis substantially aligns a point of maximum compression pressure applied to the compression piston with a point of maximum torque applied from the crankshaft during the compression stroke.

**8.** The engine of claim **4** wherein each of the first and second connecting rods has an angular bend of such magnitude that the connecting rod clears the bottom end of the associated one of the first and second cylinders.

**9.** The engine of claim **1** wherein the power and compression piston diameters are substantially different.

**10.** The engine of claim **2** wherein the first and second throws of the crankshaft have substantially different lengths.

**11.** The engine of claim **1** wherein the inlet valve permits substantially one way flow of compressed gas from the second cylinder to the pressure chamber and the outlet valve permits substantially one way flow of compressed gas from the pressure chamber to the first cylinder.

**12.** The engine of claim **1** wherein the inlet valve is a check valve.

**13.** The engine of claim **12** wherein the outlet valve is a poppet valve.

**14.** A four stroke cycle internal combustion engine comprising:

- a crankshaft, rotating about a crankshaft axis of the engine, the crankshaft having a first throw and a second throw;
- a power piston slidably received within a first cylinder;
- a first connecting rod pivotally connected to both the power piston and the first throw of the crankshaft such that the power piston reciprocates through a power stroke and an exhaust stroke of a four stroke cycle during a single revolution of the crankshaft;
- a compression piston slidably received within a second cylinder;
- a second connecting rod pivotally connected to both the compression piston and the second throw of the crankshaft such that the compression piston reciprocates through an intake stroke and a compression stroke of the same four stroke cycle during the same revolution of the crankshaft; and
- a gas passage interconnecting the first and second cylinders, the gas passage including an inlet valve and an outlet valve defining a pressure chamber therebetween,

wherein the inlet valve and the outlet valve of the gas passage substantially maintain at least a predetermined firing condition gas pressure chamber in the pressure chamber during the entire four stroke cycle.

**15.** The engine of claim **14** comprising:

- a first piston-cylinder axis along which the power piston reciprocates within the first cylinder, wherein the first piston cylinder axis has an offset from the crankshaft axis such that the first piston-cylinder axis does not intersect the crankshaft axis and passes on one side of the crankshaft axis; and
- a second piston-cylinder axis along which the compression piston reciprocates within the second cylinder, wherein the second piston cylinder axis has an offset from the crankshaft axis such that the second piston-cylinder axis does not intersect the crankshaft axis and passes on an opposing side of the crankshaft axis.



## 15

16. The engine of claim 15 wherein the offset of the first piston cylinder axis substantially aligns a point of maximum combustion pressure applied to the power piston with a point of maximum torque applied to the crankshaft during the power stroke.

17. The engine of claim 15 wherein the offset of the first piston-cylinder axis is such that the crankshaft must rotate at least 20 degrees past the point where the power piston reaches top dead center, before the power piston can reach a firing position.

18. The engine of claim 15 wherein the offset of the second piston-cylinder axis substantially aligns a point of maximum compression pressure applied to the compression piston with a point of maximum torque applied from the crankshaft during the compression stroke.

19. The engine of claim 15 wherein each of the first and second connecting rods has an angular bend of such magnitude that the connecting rod clears the bottom end of the associated one of the first and second cylinders.

20. The engine of claim 14 wherein the power and compression piston diameters are substantially different.

21. The engine of claim 14 wherein the first and second throws of the crankshaft have substantially different lengths.

22. The engine of claim 14 wherein the inlet valve permits substantially one way flow of compressed gas from the second cylinder to the pressure chamber and the outlet valve permits substantially one way flow of compressed gas from the pressure chamber to the first cylinder.

23. The engine of claim 14 wherein the inlet valve is a check valve.

24. The engine of claim 23 wherein the outlet valve is a poppet valve.

25. A four stroke cycle internal combustion engine comprising:

a crankshaft, rotating about a crankshaft axis of the engine, the crankshaft having a first throw and a second throw;

a power piston slidably received within a first cylinder;

a first connecting rod pivotally connected to both the power piston and the first throw of the crankshaft such that the power piston reciprocates through a power stroke and an exhaust stroke of a four stroke cycle during a single revolution of the crankshaft;

a first piston-cylinder axis along which the power piston reciprocates within the first cylinder, wherein the first piston-cylinder axis has an offset from the crankshaft axis such that the first piston-cylinder axis does not intersect the crankshaft axis and passes on one side of the crankshaft axis;

a compression piston slidably received within a second cylinder; and

a second connecting rod pivotally connected to both the compression piston and the second throw of the crankshaft such that the compression piston reciprocates through an intake stroke and a compression stroke of the same four stroke cycle during the same revolution of the crankshaft;

wherein the power piston leads the compression piston by a phase shift angle that is substantially equal to or greater than 20 degrees.

26. The engine of claim 25 comprising:

a second piston-cylinder axis along which the compression piston reciprocates within the second cylinder, wherein the second piston cylinder axis has an offset from the crankshaft axis such that the second piston-cylinder axis does not intersect the crankshaft axis and passes on an opposing side of the crankshaft axis.

## 16

27. The engine of claim 25 wherein the offset of the first piston cylinder axis substantially aligns a point of maximum combustion pressure applied to the power piston with a point of maximum torque applied to the crankshaft during the power stroke.

28. The engine of claim 25 wherein the offset of the first piston-cylinder axis is such that the crankshaft must rotate at least 20 degrees past the point where the power piston reaches top dead center, before the power piston can reach a firing position.

29. The engine of claim 26 wherein the offset of the second piston-cylinder axis substantially aligns a point of maximum compression pressure applied to the compression piston with a point of maximum torque applied from the crankshaft during the compression stroke.

30. The engine of claim 26 wherein each of the first and second connecting rods has an angular bend of such magnitude that the connecting rod clears the bottom end of the associated one of the first and second cylinders.

31. The engine of claim 25 wherein the power and compression piston diameters are substantially different.

32. The engine of claim 25 wherein the first and second throws of the crankshaft have substantially different lengths.

33. A four stroke cycle internal combustion engine comprising:

a crankshaft, rotating about a crankshaft axis of the engine, the crankshaft having a first throw and a second throw;

a power piston slidably received within a first cylinder;

a first connecting rod pivotally connected to both the power piston and the first throw of the crankshaft such that the power piston reciprocates through a power stroke and an exhaust stroke of a four stroke cycle during a single revolution of the crankshaft;

a first piston-cylinder axis along which the power piston reciprocates within the first cylinder, wherein the first piston cylinder axis has an offset from the crankshaft axis such that the first piston-cylinder axis does not intersect the crankshaft axis and passes on one side of the crankshaft axis;

a compression piston slidably received within a second cylinder;

a second connecting rod pivotally connected to both the compression piston and the second throw of the crankshaft such that the compression piston reciprocates through an intake stroke and a compression stroke of the same four stroke cycle during the same revolution of the crankshaft;

a second piston-cylinder axis along which the compression piston reciprocates within the second cylinder, wherein the second piston cylinder axis has an offset from the crankshaft axis such that the second piston-cylinder axis does not intersect the crankshaft axis and passes on an opposing side of the crankshaft axis; and

a gas passage interconnecting the first and second cylinders, the gas passage including an inlet valve and an outlet valve defining a pressure chamber therebetween,

wherein the inlet valve and the outlet valve of the gas passage substantially maintain at least a predetermined firing condition gas pressure in the pressure chamber during the entire four stroke cycle.

34. The engine of claim 33 wherein;

the offset of the first piston cylinder axis substantially aligns a point of maximum combustion pressure



applied to the power piston with a point of maximum torque applied to the crankshaft during the power stroke; and

the offset of the second piston-cylinder axis substantially aligns a point of maximum compression pressure applied to the compression piston with a point of maximum torque applied from the crankshaft during the compression stroke.

**35.** The engine of claim **33** wherein the offset of the first piston-cylinder axis is such that the crankshaft must rotate at least 20 degrees past the point where the power piston reaches top dead center, before the power piston can reach a firing position.

**36.** The engine of claim **33** wherein each of the first and second connecting rods has an angular bend of such magnitude that the connecting rod clears the bottom end of the associated one of the first and second cylinders.

**37.** The engine of claim **33** wherein the inlet valve permits substantially one way flow of compressed gas from the second cylinder to the pressure chamber and the outlet valve permits substantially one way flow of compressed gas from the pressure chamber to the first cylinder.

**38.** The engine of claim **33** wherein the power and compression piston diameters are substantially different.

**39.** The engine of claim **33** wherein the first and second throws of the crankshaft have substantially different lengths.

**40.** The engine of claim **33** wherein the inlet valve is a check valve.

**41.** A four stroke cycle internal combustion engine comprising:

a crankshaft, rotating about a crankshaft axis of the engine;

a power piston slidably received within a first cylinder and operatively connected to the crankshaft such that the power piston reciprocates through a power stroke and an exhaust stroke of a four stroke cycle during a single rotation of the crankshaft;

a compression piston slidably received within a second cylinder and operatively connected to the crankshaft such that the compression piston reciprocates through an intake stroke and a compression stroke of the same four stroke cycle during the same rotation of the crankshaft; and

a power piston-cylinder axis along which the power piston reciprocates within the first cylinder, wherein the power piston-cylinder axis has an offset from the crankshaft axis such that the power piston-cylinder axis does not intersect the crankshaft axis;

wherein the power piston leads the compression piston by a phase shift angle that is substantially equal to or greater than 20 degrees.

**42.** The engine of claim **41** comprising a gas passage interconnecting the first and second cylinders, the gas passage including an inlet valve and an outlet valve defining a pressure chamber therebetween, the inlet valve permitting substantially one way flow of compressed gas from the second cylinder to the pressure chamber and the outlet valve

permitting substantially one way flow of compressed gas from the pressure chamber to the first cylinder.

**43.** The engine of claim **41** comprising a compression piston-cylinder axis along which the compression piston reciprocates within the second cylinder, wherein the compression piston-cylinder axis has an offset from the crankshaft axis such that the compression piston-cylinder axis does not intersect the crankshaft axis, and wherein the compression piston-cylinder axis and the power piston-cylinder axis pass on opposing sides of the crankshaft axis.

**44.** A four stroke cycle internal combustion engine comprising:

a crankshaft, rotating about a crankshaft axis of the engine;

a power piston slidably received within a first cylinder and operatively connected to the crankshaft such that the power piston reciprocates through a power stroke and an exhaust stroke of a four stroke cycle during a single rotation of the crankshaft;

a compression piston slidably received within a second cylinder and operatively connected to the crankshaft such that the compression piston reciprocates through an intake stroke and a compression stroke of the same four stroke cycle during the same rotation of the crankshaft; and

a piston-cylinder axis along which the compression piston reciprocates within the second cylinder, wherein the piston-cylinder axis has an offset from the crankshaft axis such that the piston-cylinder axis does not intersect the crankshaft axis;

wherein the power piston leads the compression piston by a phase shift angle that is substantially equal to or greater than 20 degrees.

**45.** The engine of claim **44** comprising a gas passage interconnecting the first and second cylinders, the gas passage including an inlet valve and an outlet valve defining a pressure chamber therebetween, the inlet valve permitting substantially one way flow of compressed gas from the second cylinder to the pressure chamber and the outlet valve permitting substantially one way flow of compressed gas from the pressure chamber to the first cylinder.

**46.** The engine of claim **42** wherein the inlet valve and the outlet valve of the gas passage substantially maintain at least a predetermined firing condition gas pressure in the pressure chamber during the entire four stroke cycle.

**47.** The engine of claim **45** wherein the inlet valve and the outlet valve of the gas passage substantially maintain at least a predetermined firing condition gas pressure in the pressure chamber during the entire four stroke cycle.

**48.** The engine of claim **25** wherein the phase shift angle is approximately between 30 degrees and 60 degrees.

**49.** The engine of claim **41** wherein the phase shift angle is approximately between 30 degrees and 60 degrees.

**50.** The engine of claim **44** wherein the phase shift angle is approximately between 30 degrees and 60 degrees.



UNITED STATES PATENT AND TRADEMARK OFFICE  
**CERTIFICATE OF CORRECTION**

PATENT NO. : 6,543,225 B2  
DATED : April 8, 2003  
INVENTOR(S) : Carmelo J. Scuderi

Page 1 of 1

It is certified that error appears in the above-identified patent and that said Letters Patent is hereby corrected as shown below:

Column 14,  
Line 53, delete "chamber"

Signed and Sealed this

Twenty-fifth Day of May, 2004

A handwritten signature in black ink that reads "Jon W. Dudas". The signature is written in a cursive style with a large, looped initial "J".

---

JON W. DUDAS  
*Acting Director of the United States Patent and Trademark Office*